

2N6071, A, B  
2N6073, A, B  
2N6075, A, B

SENSITIVE GATE TRIAC  
4.0 AMPS, 200 THRU 600 VOLTS

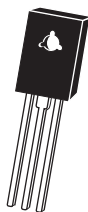

TO-126 CASE

**Central**<sup>TM</sup>  
Semiconductor Corp.

**DESCRIPTION:**

The CENTRAL SEMICONDUCTOR 2N6071, A, B series types are silicon sensitive gate triacs designed for such applications as light dimmers, motor controls, heating controls and power supplies.

**MARKING CODE: FULL PART NUMBER**

**MAXIMUM RATINGS:** ( $T_J=25^{\circ}\text{C}$  unless otherwise noted)

	SYMBOL	2N6071 2N6071A 2N6071B	2N6073 2N6073A 2N6073B	2N6075 2N6075A 2N6075B	UNITS
Peak Repetitive Off-State Voltage	$V_{DRM}, V_{RRM}$	200	400	600	V
RMS On-State Current ( $T_C=85^{\circ}\text{C}$ )	$I_T(\text{RMS})$		4.0		A
Peak One Cycle Surge (60Hz, $T_J=110^{\circ}\text{C}$ )	$I_{TSM}$		30		A
$I^2t$ Value for Fusing ( $t=8.3\text{ms}$ )	$I^2t$		3.7		$\text{A}^2\text{s}$
Peak Gate Power ( $T_C=85^{\circ}\text{C}$ )	$P_{GM}$		10		W
Average Gate Power ( $t=8.3\text{ms}$ , $T_C=85^{\circ}\text{C}$ )	$P_{G(AV)}$		0.5		W
Peak Gate Voltage ( $T_C=85^{\circ}\text{C}$ )	$V_{GM}$		5.0		V
Storage Temperature	$T_{stg}$		-40 to +150		$^{\circ}\text{C}$
Junction Temperature	$T_J$		-40 to +110		$^{\circ}\text{C}$
Thermal Resistance	$\theta_{JC}$		3.5		$^{\circ}\text{C}/\text{W}$
Thermal Resistance	$\theta_{JA}$		75		$^{\circ}\text{C}/\text{W}$
Maximum Lead Temperature	$T_L$		260		$^{\circ}\text{C}$

**ELECTRICAL CHARACTERISTICS:** ( $T_C=25^{\circ}\text{C}$  unless otherwise noted)

SYMBOL	TEST CONDITIONS	A Series		B Series		UNITS
		TYP	MAX	TYP	MAX	
$I_{DRM}, I_{RRM}$	$V_D=\text{Rated } V_{DRM}, V_{RRM}, T_J=25^{\circ}\text{C}$	10	10	10	10	$\mu\text{A}$
$I_{DRM}, I_{RRM}$	$V_D=\text{Rated } V_{DRM}, V_{RRM}, T_J=110^{\circ}\text{C}$	2.0	2.0	2.0	2.0	mA
$I_{GT}$	$V_D=12\text{V}, R_L=100\Omega, \text{QUAD I}, T_J=25^{\circ}\text{C}$	30	5.0	3.0	3.0	mA
$I_{GT}$	$V_D=12\text{V}, R_L=100\Omega, \text{QUAD II}, T_J=25^{\circ}\text{C}$	-	5.0	3.0	3.0	mA
$I_{GT}$	$V_D=12\text{V}, R_L=100\Omega, \text{QUAD III}, T_J=25^{\circ}\text{C}$	30	5.0	3.0	3.0	mA
$I_{GT}$	$V_D=12\text{V}, R_L=100\Omega, \text{QUAD IV}, T_J=25^{\circ}\text{C}$	-	10	5.0	5.0	mA
$I_{GT}$	$V_D=12\text{V}, R_L=100\Omega, \text{QUAD I}, T_J=-40^{\circ}\text{C}$	60	20	15	15	mA
$I_{GT}$	$V_D=12\text{V}, R_L=100\Omega, \text{QUAD II}, T_J=-40^{\circ}\text{C}$	-	20	15	15	mA
$I_{GT}$	$V_D=12\text{V}, R_L=100\Omega, \text{QUAD III}, T_J=-40^{\circ}\text{C}$	60	20	15	15	mA
$I_{GT}$	$V_D=12\text{V}, R_L=100\Omega, \text{QUAD IV}, T_J=-40^{\circ}\text{C}$	-	30	20	20	mA
$I_H$	$V_D=12\text{V}, I_T=1.0\text{A}, T_J=25^{\circ}\text{C}$	30	15	15	15	mA
$I_H$	$V_D=12\text{V}, I_T=1.0\text{A}, T_J=-40^{\circ}\text{C}$	70	30	30	30	mA
$V_{GT}$	$V_D=12\text{V}, R_L=100\Omega, T_J=25^{\circ}\text{C}, \text{QUAD I, II, III, IV}$	2.0	2.0	2.0	2.0	V
$V_{GT}$	$V_D=12\text{V}, R_L=100\Omega, T_J=-40^{\circ}\text{C}, \text{QUAD I, II, III, IV}$	2.5	2.5	2.5	2.5	V
$V_{TM}$	$I_{TM}=6.0\text{A}$	2.0	2.0	2.0	2.0	V
$t_{on}$	$I_{TM}=14\text{A}, I_{GT}=100\text{mA}$	1.5	1.5	1.5	1.5	$\mu\text{s}$
$dv/dt$	$V_D=\text{Rated } V_{DRM}, I_{TM}=5.7\text{A}, T_J=85^{\circ}\text{C}$	5.0	5.0	5.0	5.0	$\text{V}/\mu\text{s}$

R0 (27-April 2004)

**SENSITIVE GATE TRIAC**  
**4.0 AMPS, 200 THRU 600 VOLTS**

**TO-126 CASE - MECHANICAL OUTLINE**

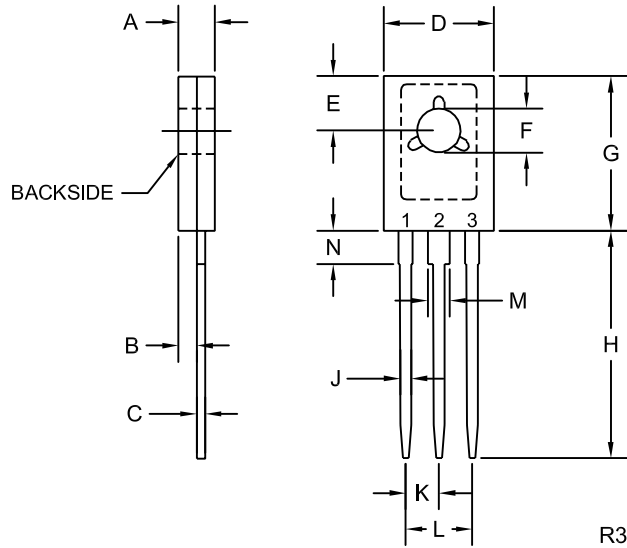

**LEAD CODE:**

- 1) MT1
- 2) MT2
- 3) GATE

**MARKING CODE:**

**FULL PART NUMBER**

SYMBOL	DIMENSIONS			
	INCHES		MILLIMETERS	
	MIN	MAX	MIN	MAX
A	0.094	0.110	2.40	2.80
B	0.050		1.27	
C	0.015	0.030	0.38	0.75
D	0.291	0.335	7.40	8.50
E	0.148		3.75	
F	0.118	0.134	3.00	3.40
G	0.413	0.472	10.50	12.00
H	0.618		15.70	
J	0.024	0.035	0.62	0.90
K	0.089		2.25	
L	0.177		4.50	
M	0.045	0.055	1.14	1.40
N	0.083		2.10	

TO-126 (REV:R3)



## OUTSTANDING SUPPORT AND SUPERIOR SERVICES

---

### PRODUCT SUPPORT

Central's operations team provides the highest level of support to insure product is delivered on-time.

- Supply management (Customer portals)
- Inventory bonding
- Consolidated shipping options
- Custom bar coding for shipments
- Custom product packing

---

### DESIGNER SUPPORT/SERVICES

Central's applications engineering team is ready to discuss your design challenges. Just ask.

- Free quick ship samples (2<sup>nd</sup> day air)
- Online technical data and parametric search
- SPICE models
- Custom electrical curves
- Environmental regulation compliance
- Customer specific screening
- Up-screening capabilities
- Special wafer diffusions
- PbSn plating options
- Package details
- Application notes
- Application and design sample kits
- Custom product and package development

---

### REQUESTING PRODUCT PLATING

1. If requesting Tin/Lead plated devices, add the suffix " TIN/LEAD" to the part number when ordering (example: 2N2222A TIN/LEAD).
2. If requesting Lead (Pb) Free plated devices, add the suffix " PBFREE" to the part number when ordering (example: 2N2222A PBFREE).

---

### CONTACT US

#### Corporate Headquarters & Customer Support Team

Central Semiconductor Corp.  
145 Adams Avenue  
Hauppauge, NY 11788 USA  
Main Tel: (631) 435-1110  
Main Fax: (631) 435-1824  
Support Team Fax: (631) 435-3388  
[www.centrasemi.com](http://www.centrasemi.com)

**Worldwide Field Representatives:**  
[www.centrasemi.com/wwreps](http://www.centrasemi.com/wwreps)

**Worldwide Distributors:**  
[www.centrasemi.com/wwdistributors](http://www.centrasemi.com/wwdistributors)

---

For the latest version of Central Semiconductor's **LIMITATIONS AND DAMAGES DISCLAIMER**, which is part of Central's Standard Terms and Conditions of sale, visit: [www.centrasemi.com/terms](http://www.centrasemi.com/terms)

## X-ON Electronics

Largest Supplier of Electrical and Electronic Components

*Click to view similar products for [Triacs](#) category:*

*Click to view products by [Central Semiconductor](#) manufacturer:*

Other Similar products are found below :

[CTA08-1000CW](#) [CTB24-800BW](#) [CTA08-1000C](#) [CTA12-800BWPT](#) [CTA16-1000B](#) [CTB24-800B](#) [BT137-600-0Q](#) [5615](#) [OT415Q](#) [2N6075A](#)  
[NTE5629](#) [NTE5688](#) [CTB08-400CW](#) [D31410](#) [T2535T-8I](#) [BTA204-600D,127](#) [BTA425Z-800BTQ](#) [KS100N12](#) [TOPT16-800C0,127](#)  
[OT408,135](#) [BT134-800E](#) [BT136D](#) [BTB16Q-600BW](#) [Z0409MF](#) [BTA06-600BRG](#) [BTA06-800BWRG](#) [BTA08-600BRG](#) [BTA08-800B](#)  
[BT136-600,127](#) [MAC97A6,116](#) [BT137-600E,127](#) [BTB16-600CW3G](#) [BTB16-600CW3G](#) [Z0109MN,135](#) [T825T-6I](#) [T1220T-6I](#) [NTE5638](#)  
[ACST1235-8FP](#) [BT136X-600E,127](#) [MAC4DLM-1G](#) [BT134-600D,127](#) [BTA08-600BW3G](#) [NTE56008](#) [NTE56017](#) [NTE56018](#) [NTE56059](#)  
[NTE5608](#) [NTE5609](#) [NTE5656](#) [NTE56020](#)