

| | |
|-----------|-----------|
| CMPD2003 | CMPD2004 |
| CMPD2003A | CMPD2004A |
| CMPD2003C | CMPD2004C |
| CMPD2003S | CMPD2004S |

**SURFACE MOUNT
HIGH VOLTAGE
SILICON SWITCHING DIODE**



SOT-23 CASE



www.centrialsemi.com

DESCRIPTION:

The CENTRAL SEMICONDUCTOR CMPD2003, CMPD2003A, CMPD2003C, CMPD2003S, CMPD2004, CMPD2004A, CMPD2004C and CMPD2004S types are silicon switching diodes manufactured by the epitaxial planar process, designed for applications requiring high voltage capability.

The following configurations are available:

| | |
|------------------|----------------------|
| CMPD2003 | SINGLE |
| CMPD2003A | DUAL, COMMON ANODE |
| CMPD2003C | DUAL, COMMON CATHODE |
| CMPD2003S | DUAL, IN SERIES |
| CMPD2004 | SINGLE |
| CMPD2004A | DUAL, COMMON ANODE |
| CMPD2004C | DUAL, COMMON CATHODE |
| CMPD2004S | DUAL, IN SERIES |

| |
|--------------------------|
| MARKING CODE: A82 |
| MARKING CODE: 8A2 |
| MARKING CODE: C3C |
| MARKING CODE: C3S |
| MARKING CODE: D53 |
| MARKING CODE: DB8 |
| MARKING CODE: DB7 |
| MARKING CODE: DB6 |

MAXIMUM RATINGS: (T_A=25°C)

| |
|--|
| Continuous Reverse Voltage |
| Peak Repetitive Reverse Voltage |
| Average Forward Current |
| Continuous Forward Current |
| Peak Repetitive Forward Current |
| Peak Forward Surge Current, tp=1.0µs |
| Peak Forward Surge Current, tp=1.0s |
| Power Dissipation |
| Operating and Storage Junction Temperature |
| Thermal Resistance |

| SYMBOL | CMPD2003 | CMPD2004 | UNITS |
|-----------------------------------|-----------|-------------|-------|
| | CMPD2003A | CMPD2004A | |
| | CMPD2003C | CMPD2004C | |
| | CMPD2003S | CMPD2004S | |
| V _R | 200 | 240 | V |
| V _{RRM} | 250 | 300 | V |
| I _O | 200 | 200 | mA |
| I _F | 250 | 225 | mA |
| I _{FRM} | | 625 | mA |
| I _{FSM} | | 4.0 | A |
| I _{FSM} | | 1.0 | A |
| P _D | | 350 | mW |
| T _J , T _{stg} | | -65 to +150 | °C |
| θ _{JA} | | 357 | °C/W |

CMPD2003 CMPD2004
 CMPD2003A CMPD2004A
 CMPD2003C CMPD2004C
 CMPD2003S CMPD2004S



**SURFACE MOUNT
 HIGH VOLTAGE
 SILICON SWITCHING DIODE**

ELECTRICAL CHARACTERISTICS PER DIODE: ($T_A=25^\circ\text{C}$ unless otherwise noted)

| SYMBOL | TEST CONDITIONS | CMPD2003 | | CMPD2004 | | UNITS |
|----------|--|----------|------|----------|-----|---------------|
| | | MIN | MAX | MIN | MAX | |
| I_R | $V_R=200\text{V}$ | - | 100 | - | - | nA |
| I_R | $V_R=200\text{V}, T_A=150^\circ\text{C}$ | - | 100 | - | - | μA |
| I_R | $V_R=240\text{V}$ | - | - | - | 100 | nA |
| I_R | $V_R=240\text{V}, T_A=150^\circ\text{C}$ | - | - | - | 100 | μA |
| BV_R | $I_R=100\mu\text{A}$ | 250 | - | 300 | - | V |
| V_F | $I_F=100\text{mA}$ | - | 1.0 | - | 1.0 | V |
| V_F | $I_F=200\text{mA}$ | - | 1.25 | - | - | V |
| C_T | $V_R=0, f=1.0\text{MHz}$ | - | 5.0 | - | 5.0 | pF |
| t_{rr} | $I_R=I_F=30\text{mA}, R_L=100\Omega, \text{Rec. to } 3.0\text{mA}$ | - | 50 | - | 50 | ns |

SOT-23 CASE - MECHANICAL OUTLINE

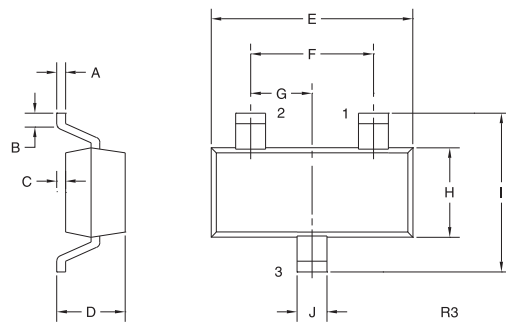

| SYMBOL | DIMENSIONS | | | |
|--------|------------|-------|-------------|------|
| | INCHES | | MILLIMETERS | |
| | MIN | MAX | MIN | MAX |
| A | 0.003 | 0.007 | 0.08 | 0.18 |
| B | 0.006 | - | 0.15 | - |
| C | - | 0.005 | - | 0.13 |
| D | 0.035 | 0.043 | 0.89 | 1.09 |
| E | 0.110 | 0.120 | 2.80 | 3.05 |
| F | 0.075 | | 1.90 | |
| G | 0.037 | | 0.95 | |
| H | 0.047 | 0.055 | 1.19 | 1.40 |
| I | 0.083 | 0.098 | 2.10 | 2.49 |
| J | 0.014 | 0.020 | 0.35 | 0.50 |

SOT-23 (REV: R3)

PIN CONFIGURATIONS

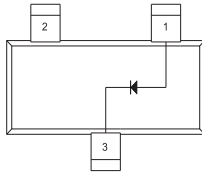

**CMPD2003
 CMPD2004**

LEAD CODE:

- 1) Anode
- 2) No Connection
- 3) Cathode

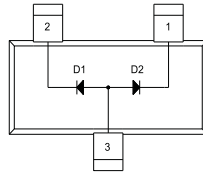

**CMPD2003A
 CMPD2004A**

LEAD CODE:

- 1) Cathode D2
- 2) Cathode D1
- 3) Anode D1, D2

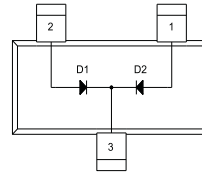

**CMPD2003C
 CMPD2004C**

LEAD CODE:

- 1) Anode D2
- 2) Anode D1
- 3) Cathode D1, D2

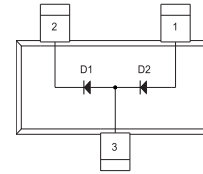

**CMPD2003S
 CMPD2004S**

LEAD CODE:

- 1) Anode D2
- 2) Cathode D1
- 3) Anode D1, Cathode D2

MARKING CODE: SEE PREVIOUS PAGE

R9 (25-January 2010)

X-ON Electronics

Largest Supplier of Electrical and Electronic Components

Click to view similar products for [Diodes - General Purpose, Power, Switching category:](#)

Click to view products by [Central Semiconductor manufacturer:](#)

Other Similar products are found below :

[RD0306T-H](#) [BAV17-TR](#) [BAV19-TR](#) [1N3611](#) [NTE156A](#) [NTE525](#) [NTE571](#) [NTE5804](#) [NTE5806](#) [NTE6244](#) [1SS181-TP](#) [1SS193,LF](#)
[1SS400CST2RA](#) [SDAA13](#) [SHN2D02FUTW1T1G](#) [LS4151GS08](#) [1N4449](#) [1N456A](#) [1N4934-E3/73](#) [1N914B](#) [1N914BTR](#) [RFUH20TB3S](#)
[BAS 28 E6327](#) [BAV199-TP](#) [BAW56DWQ-7-F](#) [BAW75-TAP](#) [MM230L-CAA](#) [IDW40E65D1](#) [JAN1N3600](#) [LL4151-GS18](#) [053684A](#)
[SMMSD4148T3G](#) [707803H](#) [NSVDAN222T1G](#) [SP000010217](#) [CDSZC01100-HF](#) [BAV199E6433HTMA1](#) [BAV70M3T5G](#) [SMBT2001T1G](#)
[NTE5801](#) [NTE5800](#) [NTE5808](#) [NTE6240](#) [NTE6248](#) [BAS28-7](#) [BAW56HDW-13](#) [BAS28 TR](#) [VS-HFA04SD60STR-M3](#)
[NSVM1MA152WKT1G](#) [BAV99TQ-13-F](#)