

**Compact, Low-Cost Global Embedded Modem**

**Description**

The Xecom XE5690SM provides a complete, global modem as a compact module. Only Xecom offers embedded modems in both through-hole and surface-mount form.

User transferable FCC Part 68 registration comes with every Xecom modem. This allows the system designer to add a modem to a process control, remote monitoring, point-of-sale, or remote diagnostic system without Part 68 certification.

The XE5690SM footprint is 20% smaller than the most popular embedded modems. The surface-mount version frees additional space on the bottom of the application board. The space efficient design allows the development engineer greater flexibility in placement of the modem within the host system.

Xecom offers two interchangeable models: The XE2422SM offers low speed connectivity at low cost; the XE5692SM permits fast V.92 connections.

**Features**

- Models - XE5690SM (Through-Hole Model)  
                  XE5690SM-1 (Surface-Mount Model)
- Size:        XE5690SM: 2.175" x 1.0" x 0.30"  
                  XE5690SM-1: 2.175" x 1.0" x 0.152"
- Data transfer at rates from 300 bps to 56 Kbps
- Control & configuration via AT commands.
- 3.3 and 5 volt compatible serial interface
- V.42 error control and V.42bis data compression.
- Shared line features prevent modem operation from interfering with voice communications.
- Boot command automatically loads user default configuration.
- Complete integrated DAA.
- User transferrable FCC Part 68 registration
- World-wide telephone networks compliance.
- UL60950 Recognition
- Low Power operation, 3.3 Volts, 100 milliwatts;

**XE5690SM BLOCK DIAGRAM**

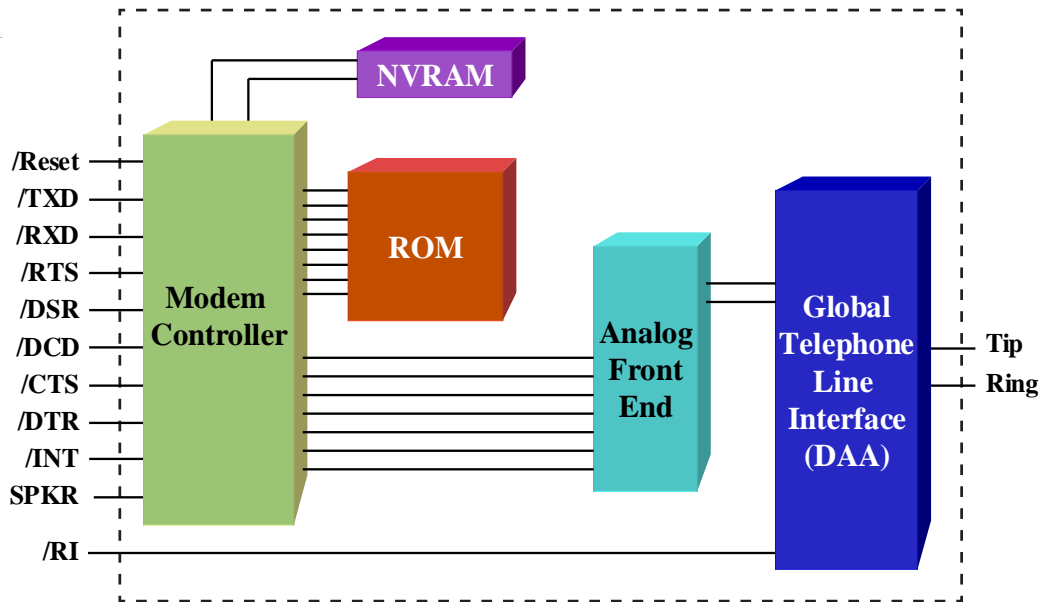

## XE5690SM Mechanical Specifications (Through-Hole Version)

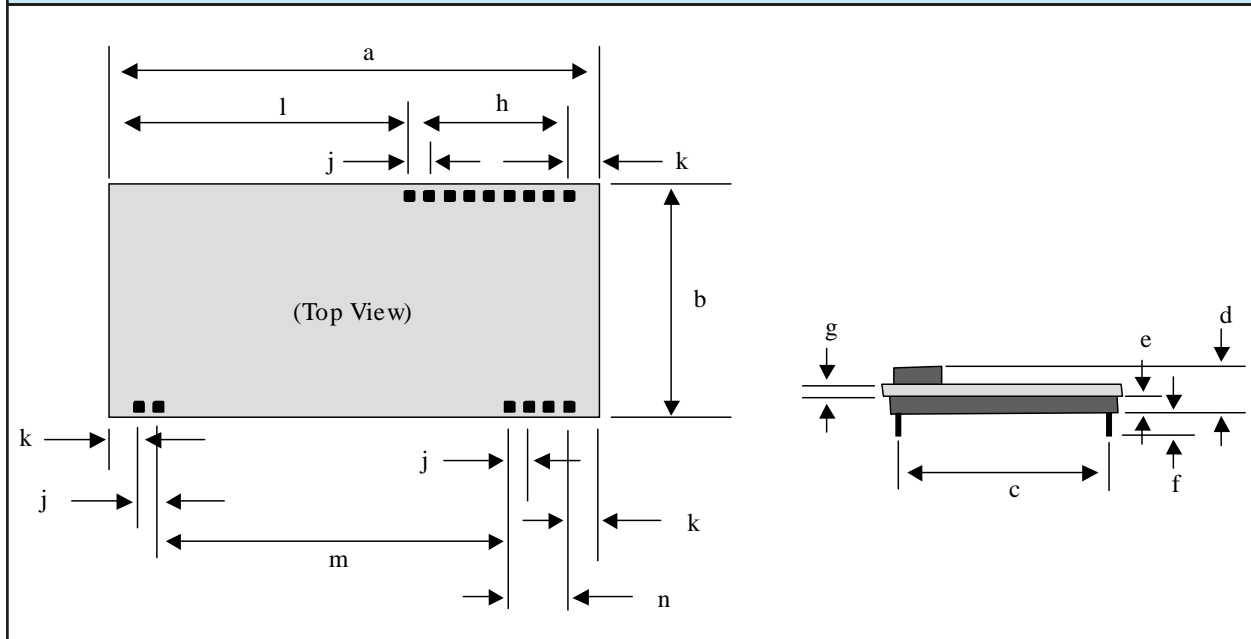

Dimension	Inches			Millimeters		
	Min	Typ	Max	Min	Typ	Max
a	2.170	2.175	2.180	55.12	55.24	55.37
b	0.995	1.000	1.005	25.27	25.40	25.53
c	0.890	0.900	0.910	22.61	22.86	23.11
d	0.242	0.252	0.262	6.15	6.40	6.65
e	0.090	0.100	0.110	2.29	2.54	2.79
f	0.140	0.150	0.160	3.56	3.81	4.06
g	0.059	0.062	0.065	1.50	1.57	1.65
h	0.790	0.800	0.810	20.07	20.32	20.83
j	0.090	0.100	0.110	2.29	2.54	2.79
k	0.137	0.1375	0.138	3.48	3.49	3.51
l	1.230	1.240	1.250	31.24	31.50	31.75
m	1.490	1.500	1.510	37.85	38.10	38.35
n	0.290	0.300	0.310	7.37	7.62	7.87

**XE5690SM-1 Mechanical Specifications (Surface-Mount Version)**

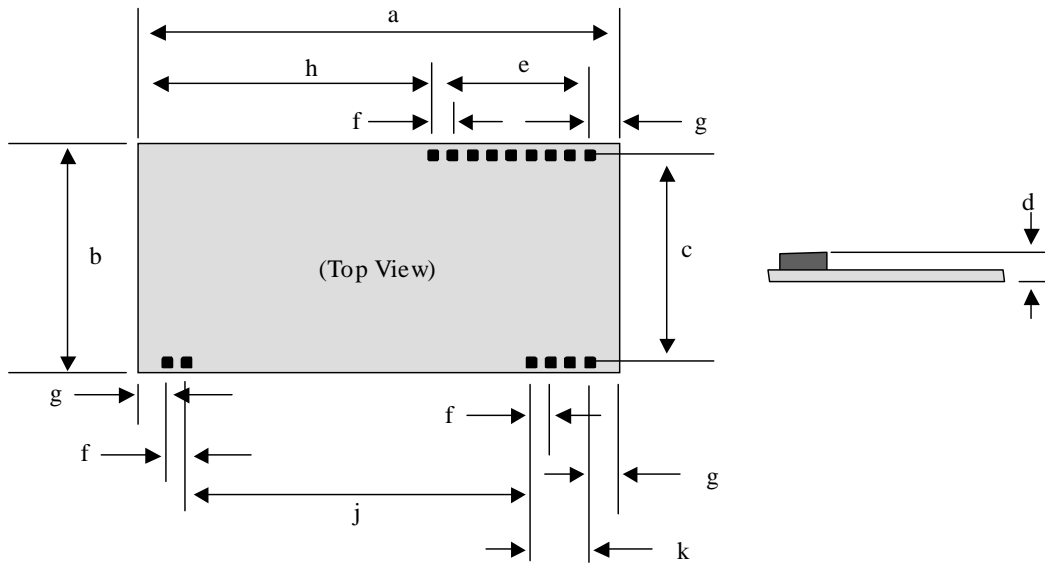

Dimension	Inches			Millimeters		
	Min	Typ	Max	Min	Typ	Max
a	2.170	2.175	2.180	55.12	55.24	55.37
b	0.995	1.000	1.005	25.27	25.40	25.53
c	0.890	0.900	0.910	22.61	22.86	23.11
d	0.142	0.152	0.162	3.61	3.86	4.11
e	0.790	0.800	0.810	20.07	20.32	20.83
f	0.090	0.100	0.110	2.29	2.54	2.79
g	0.137	0.1375	0.138	3.48	3.49	3.51
h	1.230	1.240	1.250	31.24	31.50	31.75
j	1.490	1.500	1.510	37.85	38.10	38.35
k	0.290	0.300	0.310	7.37	7.62	7.87

## XE5690SM Pin Configuration

Top View

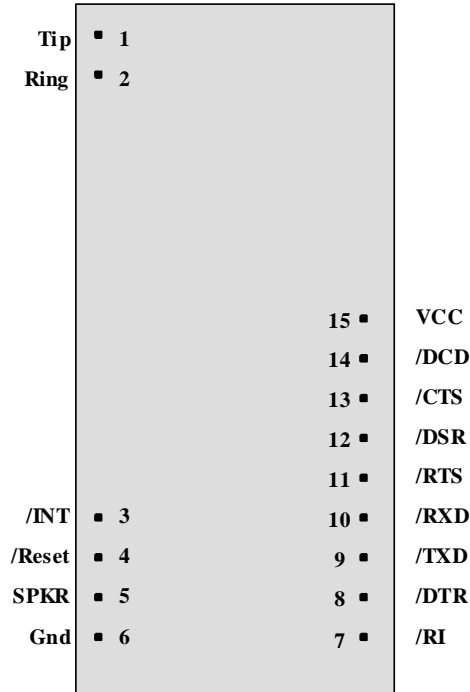

### Pin Descriptions

PIN	NAME	DESCRIPTION
1	Tip	<p>The Ring and Tip signals connect the modem to the telephone line. FCC Part 68 Rules require a 1500 volt isolation barrier between the telephone line and all other circuits. This isolation must be preserved throughout the system.</p> <p>The telephone company places a DC “Battery” voltage across Tip and Ring on public switched telephone lines. The XE5690SM operates regardless of the polarity of this voltage. The “Battery” voltage drives up to 100 milliamperes of DC loop current.</p> <p>UL60950 requires minimum creepage and clearances distances between the Tip and Ring and all other circuits. Clearance is the shortest distance between conductive circuits; creepage is the distance between conductive points along the surface</p>
2	Ring	<p>The Ring and Tip signals connect the modem to the telephone line. FCC Part 68 Rules require a 1500 volt isolation barrier between the telephone line and all other circuits. This isolation must be preserved throughout the system.</p> <p>The telephone company places a DC “Battery” voltage across Tip and Ring on public switched telephone lines. The XE5690SM operates regardless of the polarity of this voltage. The “Battery” voltage drives up to 100 milliamperes of DC loop current.</p>

## XE5690SM Pin Descriptions (continued)

PIN	NAME	DESCRIPTION
		UL60950 requires minimum creepage and clearances distances between the Tip and Ring and all other circuits. Clearance is the shortest distance between conductive circuits; creepage is the distance between conductive points along the surface.
3	/INT	/INT provides an active low hardware interrupt signal from the XE5690SM. The operation of this interrupt pin is programmable using the modem's register U70.
4	/RESET	/RESET is an active low input which initiates a modem hardware reset. /RESET must be active for a minimum of 100 milliseconds for a proper modem reset sequence. No external reset is required; if none is used the RESET signal should be left open.
5	SPKR	SPKR provides a Pulse Width Modulated version of the signal on Tip and Ring allowing connection of a speaker to the modem to monitor modem operations. The recommended speaker circuit is shown on Page 9 of this data sheet. The signal on SPKR is controlled by the ATL and ATM commands.
6	Ground	Ground provides the reference voltage for all host interface signals.
7	/RI	The /RI signal reports on the presence of an incoming ring signal. When a ring occurs across Tip and Ring, the /RI output goes low and toggles with the cadence of the ring signal.
8	/DTR	/DTR is an active low input to the modem. An active /DTR signals the terminal is available for communications. The AT&D command determines how the modem interprets activity on /DTR.
9	/TXD	/TXD provides the path for transmitted data and modem commands to be passed from the host controller to the modem.
10	/RXD	/RXD provides the path for received data and modem responses to be sent from the modem to the host controller.
11	/RTS	/RTS is an active low input to the modem. When hardware flow control is set, an active /RTS indicates to the modem that the host has data to send.
12	/DSR	/DSR is an active low output from the modem and is forced to the active condition.
13	/CTS	/CTS is an active low output from the modem. When hardware flow control is set, the modem asserts /CTS to indicate that it can accept data from the terminal equipment on /TXD.
14	/DCD	/DCD is an active low output from the modem. An active /DCD indicates the presence of a valid carrier signal. The AT&C command controls when the XE5690SM asserts /DCD.
15	VCC	VCC provides 3.3 volt power to the modem.

## XE5690SM Electrical Specifications

Parameter	Min	Typ	Max	Units	Comments
VCC	3.13	3.3	3.47	Volts	
ICC		30	35	mA	On Line
		5		mA	Sleep
		.14		mA	Power Down
Ring Voltage Detected	26		150	VRMS	Type B Ringer
Ring Frequency Detected	15.3		68	Hz	Type B Ringer
Telephone Loop Current	10	40	100	ma	
Line Impedance		600		Ohms	
Data Transmit level		-12.0	-9.0	dBm	
DTMF Transmit Level		-2.5	0	dBm	Avg over 3 second interval
Voh	2.4		5.0	Volts	
Vol			0.4	Volts	
Vih	2.0		5.0	Volts	
Vil	-0.3		0.8	Volts	

### XE5690SM ABSOLUTE MAXIMUM RATINGS

Storage Temperature	-25° C to +85° C
<sup>1</sup> Maximum Operating Temperature Range	0° C to +70° C
VCC	3.6 Volts
<sup>1</sup> The XE5690SM can be ordered with an Operating Temperature of -40° C to +85° C at extra cost. Order XE5690SM-ITR or XE5690SM-1ITR or to specify Industrial Temperature Range (ITR).	

## XE5690SM-1 Surface-Mount Soldering Instructions

The XE5690SM-1 is subject to damage if over-exposed to heat during solder reflow operations. Following the soldering instructions below will ensure that the process of soldering the module to the board does not damage the modem.

Maximum Temperature	220° C
Maximum Time at 220° C	20 Seconds
Maximum Time above Eutectic (180° C)	90 Seconds
Maximum Preheat Dwell Time	180 Seconds

### Maximum Recommended Solder Temperature Profile

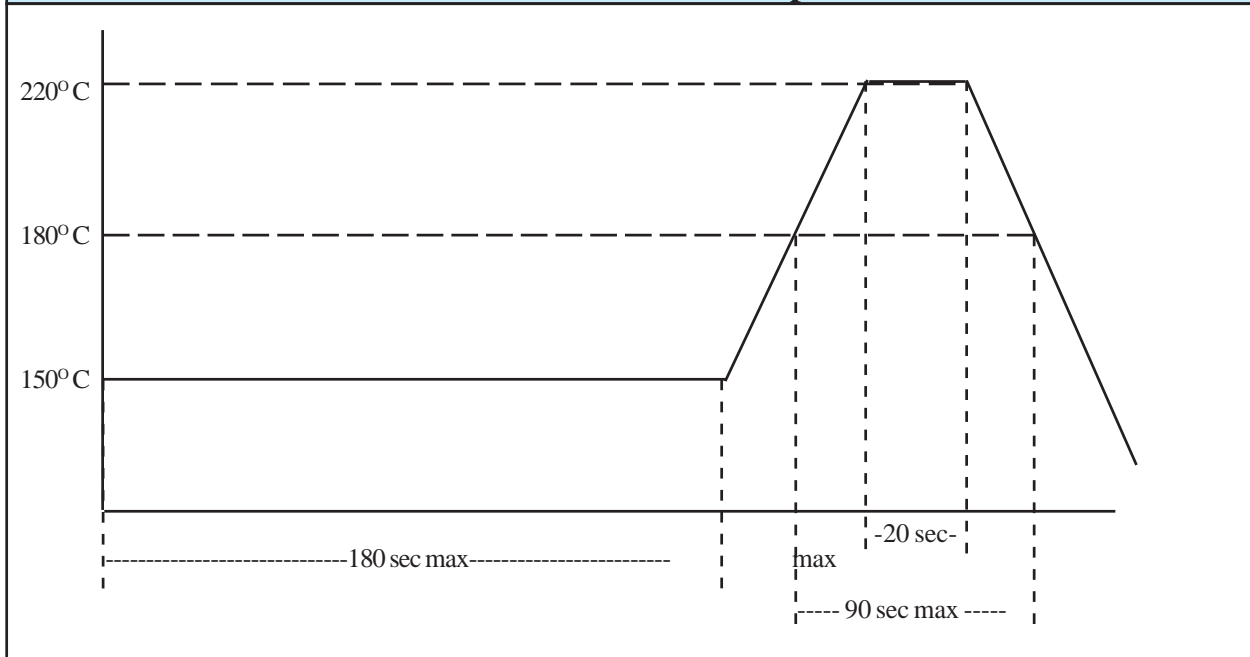

## XE5690SM Typical Connection Diagram

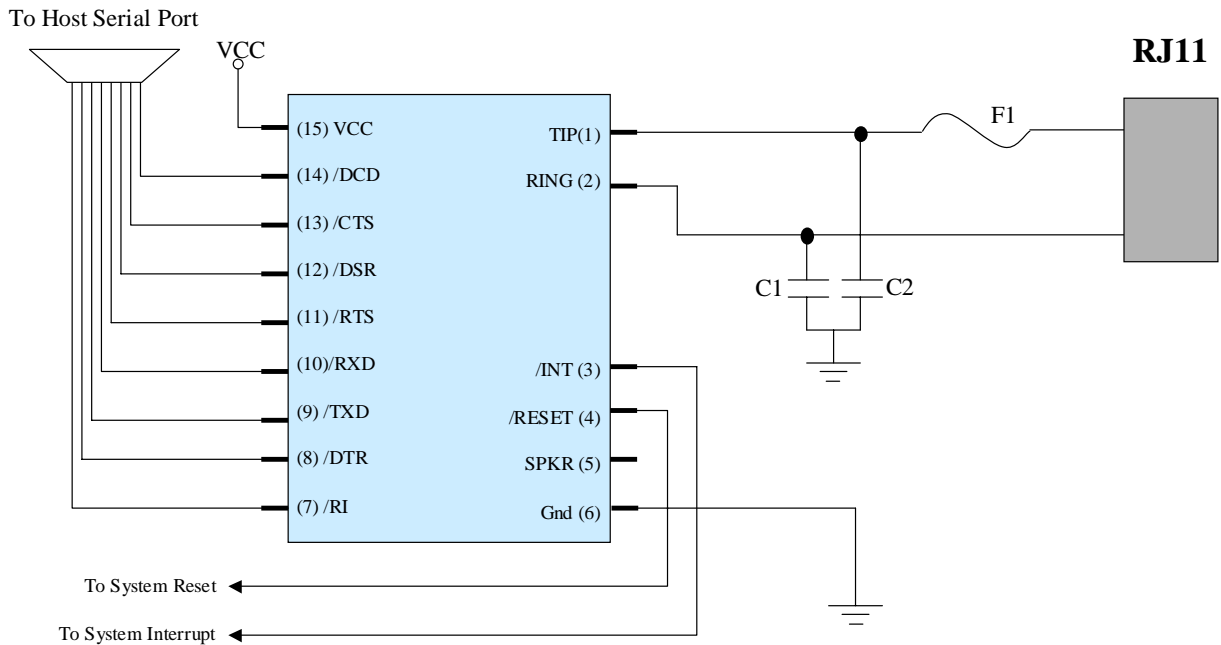

### Parts List for XE5690SM Typical Connection Diagram

Reference Designation	Qty	Description
C1, C2	2	Cap. 1000 pfd, 1500V minimum
F1	1	PTC, TR600-150

#### Notes:

- Capacitors, C1 and C2, may be required for EMI filtering in your system. Without these components you may experience unintended radiation when the telephone cable is attached. C1 and C2 are high-voltage capacitors. We recommend the Johanson Dielectrics 502S47N102KV6T. This 1000 pfd, 3000 volt capacitor will direct the high frequency harmonics to the system ground. These capacitors must be rated at a minimum of 1500 volts to maintain the isolation required by FCC Part 68 Rules.
- F1 is a positive thermal coefficient (PTC) device which protects the modem from excessive current flow. These devices are required for your system to pass UL60950. Fuses may be used in place of the PTC's



## Recommended SPKR Connection

The SPKR output on the XE5690SM provides a Pulse Width Modulated version of the signal on Tip and Ring. This permits audio monitoring of modem operations through a connected speaker. The schematic below shows the recommended circuit for the audio monitor

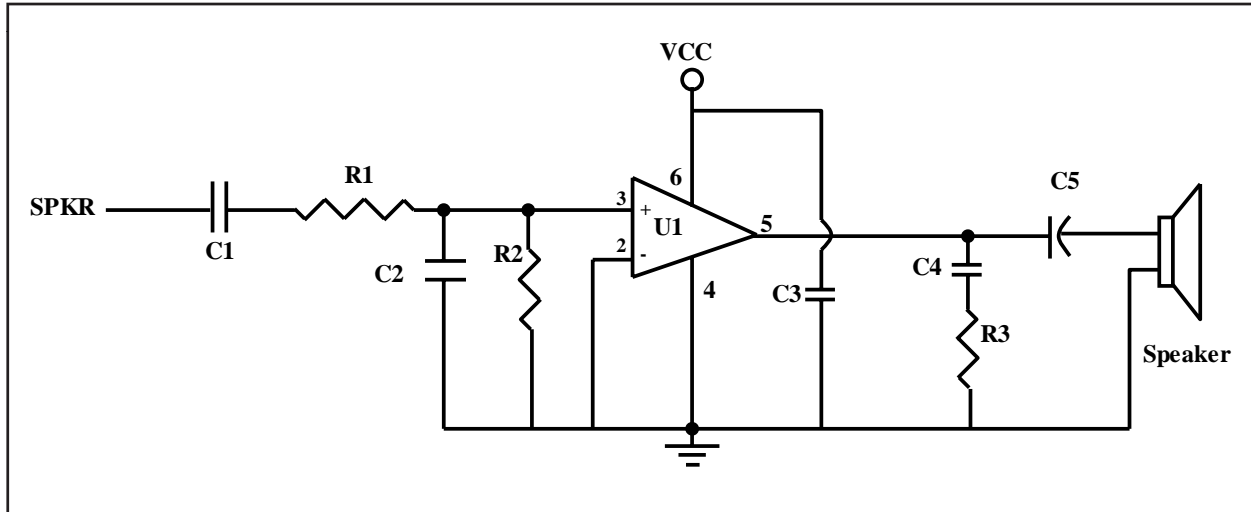

Reference Designation	Qty	Value
C1, C3, C4	3	0.1 ufd, 16 V $\pm$ 20%
C2	1	820 pfd, 16V $\pm$ 20%
C5	1	100 ufd, 16V $\pm$ 20%
R1	1	47K, 1/10 W, $\pm$ 5%
R2	1	10K, 1/10 W, $\pm$ 5%
R3	1	140 ohm, 1/10 W, $\pm$ 5%
U1	1	LM386

---

## XE5690SM Shared Line Features

The XE5690SM can monitor telephone line conditions before, after and during calls. This allows the system to avoid conflicts with other equipment connected to the same telephone line. There are two line monitoring modes; Connect Detect and Handset Interrupt.

### Connect Detect:

Connect Detect is active when the XE5690SM is on-hook. With AT%V2 selected the XE5690SM verifies the availability of the telephone line by checking the DC loop voltage before going off-hook for dialing or answering a call. The nominal value of loop voltage is stored in register U85, typically 48 volts. The XE5690SM can detect either the lack of an installed telephone line or that the connected line is in use.

**NO LINE** If the telephone line is disconnected from the modem, the voltage on Tip and Ring will be zero. If the modem reads a DC loop voltage of 3 volts or less, the modem will not go off-hook and will issue the “NO LINE” response.

**LINE IN USE** If a telephone handset, fax machine or other piece of equipment connected to the telephone line is in use, the DC loop voltage will drop. Typically the DC loop voltage will drop to around 10 volts while the telephone line is in use. If the modem sees a DC loop voltage between 3 volts and 85% of the nominal loop voltage (41 volts typical), the modem will not go off-hook but will transmit the “LINE IN USE” response

If neither the No Line or Line in Use conditions is true, the XE5690SM goes off-hook and completes the original command.

### Handset Interrupt:

The Handset Interrupt feature permits the modem to yield the telephone line to other equipment connected to the same line. This prevents the XE5690SM from blocking outgoing emergency calls when the line is shared as in a residential

application including set top boxes and automated meter readers. For Handset Interrupt the modem monitors the loop current while it is off-hook. The Loop current will drop if a piece of equipment connected to the same telephone line goes off-hook. The Handset Interrupt function is controlled by registers U77 and U78. U78 defines when the Handset Interrupt is operable, and U77 allows the operator to configure the modem to disconnect immediately upon detecting another piece of equipment on the telephone line.

**U77:** Bit 11 of U77 sets the XE5690SM to automatically disconnect any time another piece of equipment connects to the line while the modem is off-hook. This configuration is recommended when the modem will be sharing a line with a telephone handset as it provides the quickest access to the phone line for emergency calls. If U77 bit 11 is not set, then U70 bit 10 should be. U70 bit 10 causes the modem to provide an interrupt when the off-hook condition of the other equipment is detected.

**U78** Bits 14 and 15 of U78 control when the Handset Interrupt will be active.

- If both bits are reset, Handset Interrupt is disabled.
- If only bit 14 is set, the modem monitors the line for a Handset Interrupt after dialing.
- If only bit 15 is set, the XE5690SM activates Handset Interrupt when the timer set by bits 0 to 7 expires. Bits 0-7 set this timer in 500 millisecond increments.
- If both bits 14 and 15 are set, the modem starts monitoring for a Handset Interrupt after the modem handshake is completed.

---

## XE5690SM AT Commands

The XE5690SM uses "AT" commands for configuration and control. This section describes the AT command format and lists the commands, registers and result codes.

**Command Mode:** The XE5690SM enters command mode on power-up, reset, a lost connection, or receipt of the escape code. In command mode the modem accepts commands from the host on transmit data. Appropriate result codes are returned on received data.

### Command Line Format

AT commands follow a strict format. Each command line, except A/, begins with the prefix AT. The "A" and "T" may be both upper case or both lower case but cannot be of different cases. The modem determines data rate of the host equipment by measuring the width of the incoming bits of the "A" and "T."

Multiple commands may be combined into a single command line of up to 48 characters. Commands are executed in the sequence they appear upon receipt of a carriage return. Spaces inserted into the command line are not placed in the buffer.

The command line can be edited with a backspace before it is executed. The backspace erases the previous character in the command line. Register S5 allows the user to select a character other than backspace to edit the command line.

If the command buffer overflows, the modem issues an "ERROR" result code, and the command line is not executed. Register S3 allows the user to select a character other than a carriage return to terminate the command line.

**Re-Execute Last Command** - The A/ command causes the modem to re-execute the last command line. This is the only command which does not require the "AT" prefix.

**Omitted Parameters** - Most commands include a parameter which determines how the functions will be set. When the command parameter is omitted from the command string, it is assumed to be a 0.

**Escape Characters** - A 3 character escape sequence may be entered to switch the modem into command mode while on line. The escape character, set by Register S2, must be entered 3 times in succession to execute the escape. An AT command must then be entered within the period defined by S12 to enter command mode. The default escape sequence is "+++."

**Result Codes** - The modem issues a result code after each action. Result codes may be sent as full words, one or two digit numeric codes, or may be disabled all together. Each result code ends with a carriage return when numeric result codes are chosen. When full word result codes are chosen, a Line Feed and Carriage Return precede and follow each result code.

## XE5690SM Boot Command

The XE5690SM allows a default command string to be automatically loaded into the modem on power-up or modem reset. A series of commands loads the default command string in Hex form into the modem's EEPROM. The EEPROM has 256 bytes available for command storage.

The sequence to load the default commands into EEPROM must begin with the Boot command and ends with a double carriage return. All commands are loaded into the EEPROM in Hex form beginning with address M0000. Up to 8 addresses may be loaded with each command in the sequence.

The following example uses a typical configuration for an embedded application. ATE0 disables command echo; ATQ1 disabled modem responses, and ATSO=1 sets the modem to automatically answer on the first ring. This sequence is loaded into the modem EEPROM with the Boot command using the command sequence below. This places the modem into the desired configuration each time power is applied or the modem is reset

### Boot Command Sequence

Command	Description
AT:M0000,42,4F,4F,54,0D,41,54,45	Load characters "B,O,O,T,<CR>,A,T,E" in EEPROM beginning at address M0000
AT:M0008,30,0D,41,54,51,31,0D,41	Load characters "0,<CR>,A,T,Q,1,<CR>,A" in EEPROM beginning at address M0008
AT:M0010,54,53,30,3D,31,0D,0D,0D	Load characters "T,S,0,=,1,<CR>,<CR>,<CR>" in EEPROM beginning at address M0010

## XE5690SM AT Commands

**An asterisk indicates the factory default**

**A - Answer Command -**

**D - Dial Command -**

0-9, A-D, #, \* = Dialing Digits

P = Pulse dial

T = Tone dial

W = Wait for dial tone

, = Pause for the duration of S8

! = Switch hook flash

; = Return to the command state

**En - Command Echo**

n=0 Do not echo commands

n=1 Enable command echo \*

**Hn - Switch Hook Control -**

n=0 Switch hook relay opens

n=1 Switch hook relay closes

**In - Modem Identification**

**Mn - Speaker Activity -**

n=0 Speaker off \*

n=1 Speaker on until carrier received

n=2 Speaker remains on

n=3 Speaker on after dialing until DCD active

**On - On Line**

n=0 Return On Line with no retrain \*

n=1 Initiate retrain while returning On line.

n=2 Initiate ratere negotiation while returning On line.

**Qn - Responses**

n=0 Send responses \*

n=1 No Responses

**Sr? - Interrogate Register -**

**Sr=n - Set Register Value -**

**S\$ - List values of all S-Registers -**

## XE5690SM AT Commands

### **Vn - Result Codes -**

- n=0 Numeric Result Codes
- n=1 English Word Result Codes\*

### **Xn - Result Code Set -**

- n=0 Responses 0-4
- n=1 Responses 0-5 & 10
- n=2 Responses 0-6 & 10
- n=3 Responses 0-5, 7 & 10
- n=4 Responses 0-8 & 10\*
- n=5 All Responses

### **Z - Reset -**

### **&Gn - Maximum Data Rate Selection**

- n=3 1200 bps
- n=4 2400 bps
- n=5 4800 bps
- n=6 7200 bps
- n=7 9600 bps
- n=8 12,000 bps
- n=9 14,400 bps
- n=10 16,800 bps
- n=11 19,200 bps
- n=12 21,600 bps
- n=13 24,000 bps
- n=14 26,400 bps
- n=15 28,800 bps
- n=16 31,200 bps
- n=17 33,600 bps \*

### **&Hn - Protocol Selection**

- n=0 V.90 with auto fallback to 300 bps \*
- n=1 V.90 with fallback to 28,800 bps
- n=2 V.34 with automatic fall back to 300 bps
- n=3 V.34 only (33,600 bps to 2400 bps)
- n=4 V.32bis w automatic fallback to 300 bps
- n=5 V.32bis only (14,400 to 4800 bps)
- n=6 V.22bis (2400 or 1200 bps) \*
- n=7 V.22 (1200 bps)
- n=8 Bell 212 (1200 bps)
- n=9 Bell 103 (300 bps)
- n=10 V.21 (300 bps)
- n=11 V.23 (1200/75 bps)

### **&\$ - Display current AT& settings.**

### **&Tn - Modem Test Modes**

- n=0 Cancel Test Mode
- n=3 Initiate Analog Loopback

### **&Z - Sleep Mode; wake on incoming Ring**

### **%B - Report Blacklisted Numbers**

### **%C - V.42bis Data Compression**

- n=0 Data Compression Disabled \*
- n=1 Bidirectional Data Compression Enabled
- n=2 Data Compression Transmit Only
- n=3 Data Compression Receive Only

### **%On - Answer Mode**

- n=1 Answer in Answer Mode \*
- n=2 Answer in Originate Mode

### **%Vn - Shared Line Use**

- n=0 No auto detection of local line status \*
- n=2 Check line voltage before going off-hook. "NO LINE" response if line is unavailable and "LINE IN USE" if line is off hook.

### **%%\$ - Display current AT% settings.**

### **\Bn - Character Length**

- n=0 6N1; 6 data bits, no parity, 1 stop bit
- n=1 7N1; 7 data bits, no parity, 1 stop bit
- n=2 7P1; 7 data bits, 1 stop bit, parity set by AT\P command.
- n=3 8N1; 8 data bits, no parity, 1 stop bit, \*
- n=5 8P1; 8 data bits, 1 stop bit, parity set by AT\P command.
- n=6 8X1; 8 data bits, 1 stop bit, 1 escape bit enabling 9th bit escape mode.

### **\Nn - Error Control Mode**

- n=0 Normal Mode
- n=2 MNP Required
- n=3 V.42 auto reliable mode \*
- n=4 LAPM required for connection
- n=5 V.42 or MNP required

### **\Pn - Parity Setting**

- n=0 Even Parity selected \*
- n=1 Space Parity selected
- n=2 Odd Parity selected
- n=3 mark Parity selected

## XE5690SM AT Commands

### \Qn - Modem to DTE Flow Control

- n=0 No Flow Control
- n=2 CTS Flow Control only \*
- n=3 RTS/CTS Flow Control
- n=4 XON/XOFF Flow Control

### \Tn -DTE Rate

- n=0 300 bps
- n=1 600 bps
- n=2 1200 bps
- n=3 2400 bps
- n=4 4800 bps
- n=5 7200 bps
- n=6 9600 bps
- n=7 12.0 Kbps
- n=8 14.4 Kbps
- n=9 19.2 Kbps
- n=10 38.4 Kbps
- n=11 57.6 Kbps
- n=12 115.2 Kbps
- n=13 230.4 Kbps
- n=14 460.8 Kbps
- n=15 921.6 Kbps
- n=16 Autobaud on AT command \*

### \Vn - Connect Response

- n=0 Issue Connect and Protocol Responses \*
- n=2 Issue Connect Response only
- n=4 Issue Connect and Protocol Responses with both transmit and receive data rates.

### :I - Read Interrupts -

Reports the lower 8 bits of User Register U70. Reading the interrupts clears them and resets the /INT pin.

### :M#### - Load Boot Command to EEPROM beginning at address ####.

### :R- Read all User Registers

### :Rnn - Read user Register nn

### :Unn,xxxx - Write hex value xxxx to User

Register nn. To write to multiple User Registers in one command line, address the first register in the sequence. Subsequent values will be loaded into successive registers The :U command uses the format AT:Unn, xxxx, yyyy, zzzz, ...<CR> to load multiple registers.

### +GCI=n - Country Configuration

- 0 = Japan
- 9 = Australia
- A = Austria
- F = Belgium
- 16 = Brazil
- 1B = Bulgaria
- 20 = Canada
- 26 = China
- 27 = Columbia
- 2E = Czech Republic
- 31 = Denmark
- 35 = Ecuador
- 3C = Finland
- 3D = France
- 42 = Germany
- 46 = Greece
- 50 = Hong Kong
- 51 = Hungary
- 53 = India
- 57 = Ireland
- 58 = Israel
- 59 = Italy
- 61 = South Korea
- 69 = Luxembourg
- 6C = Malaysia
- 73 = Mexico
- 7B = Netherlands
- 7E = New Zealand
- 82 = Norway
- 87 = Paraguay
- 89 = Phillipines
- 8A = Poland
- 8B = Portugal
- 9C = Singapore
- 9F = South Africa
- A0 = Spain
- A5 = Sweden
- A6 = Switzerland
- B4 = United Kingdom
- B5 = United States \*
- B8 = Russia
- FE = Taiwan

### +GCI? - Report Country Configuration

## XE5690SM AT Commands

### +MS - Select Modulation -

AT+MS sets the modulation and data rates to be supported by the modem. The command format is: AT+MS=a, b, c, d, e, f<CR>

a - modulation type

- V21 - V.21 (300 bps)
- V22 - V.22 (1200 bps)
- V.22B - V.22bis (1200 or 2400 bps)
- V32 - V.32 (4800 or 9600 bps)
- V32B - V.32bis (4800 to 14,400 bps)
- V34 - V.34 (16,800 to 33,600 bps)
- V90 - V.90 (to 56,000 bps)

b - Automode Detection

- 0 - Automatic Negotiation Disabled
- 1 - Automatic Negotiation Enabled

c - Min receive data rate (300-56000 bps)

d - Max receive data rate (300-56000 bps)

e - Min transmit data rate (300-56000 bps)

f - Max transmit data rate (300-56000 bps)

### +VCID=n - Caller ID Enable

- n=0 No Caller ID \*
- n=1 Formatted Caller ID Data presented
- n=2 Raw Caller ID Data presented

### +VCDT=n - Caller ID Type

- n=0 On only after first ring
- n=1 CID Always On
- n=2 UK CID Format
- n=3 Japanese CID Format

## XE5690SM REGISTER SETTINGS

**S0 Answer on nth Ring:** S0 sets the modem to automatically answer on the nth ring.

Setting S0 to 0 disables automatic answer.

Range: 0 to 255

Units Rings

Default 0

**S1 Ring Count:** S1 is a read-only register showing the number of rings detected. If no ring is detected within 8 seconds, S1 is reset.

Range: 0 to 255

Units Rings

Default 0

**S2 Escape Character:** S2 sets the ASCII escape character. Values of 0-127 select valid characters; values from 128 to 255 disable the escape sequence.

Range: 0 to 255

Units ASCII Character

Default 43 (+)

**S3 Line Termination Character:** S3 determines the ASCII character which will terminate commands and modem responses.

Range: 0 to 127

Units ASCII Character

Default 13 (Carriage Return)

**S4 Line Feed Character:** S4 sets the ASCII character to act as a line feed character in modem responses.

Range: 0 to 127

Units ASCII Character

Default 10 (Line Feed)

**S5 Backspace Character:** S5 defines the ASCII character used as a backspace to edit the command line.

Range: 0 to 127

Units ASCII Character

Default 8 (Back Space)



## XE5690SM REGISTER SETTINGS

- S6 Dial Tone Wait Time:** S6 determines how long the modem waits for dial tone before dialing. The Dial Tone Wait Time cannot be set to less than two seconds.
- Range: 0 to 255  
Units Seconds  
Default 2
- S7 Wait for Carrier after Dialing:** S7 determines how long the modem waits for a valid carrier signal after dialing.
- Range: 0 to 255  
Units Seconds  
Default 80
- S8 Comma Pause Time:** S8 defines the duration of the pause initiated by a comma in the dialing string. The pause is generally used when waiting for a second dial tone.
- Range: 0 to 255  
Units Seconds  
Default 2
- S9 Carrier Detect Response Time:** S9 establishes the length of time the remote modem's carrier must be present to be recognized as valid.
- Range: 1 to 255  
Units 0.1 Seconds  
Default 6
- S10 Carrier Off Disconnect Delay:** S10 selects how long carrier must be lost before the modem disconnects. If S10 is smaller than S9 or S10 is set to 255, the modem will not disconnect on any loss of carrier.
- Range: 1 to 255  
Units 0.1 Seconds  
Default 14
- S12 Escape Code Guard Timer:** S12 sets the escape sequence guard timer. If characters are received before or after the escape sequence, within the guard timer, the modem aborts the escape and remains in data mode.
- Range: 10 to 255  
Units 0.02 Seconds  
Default 50
- S14 Wait for Dial Tone Delay:** S14 determines how long the modem will wait for dial tone when the W dial modifier is used.
- Range: 0 to 255  
Units Seconds  
Default 12
- S24 Sleep Inactivity Timer:** S24 sets the length of inactivity before the modem enters sleep mode. Zero disables sleep mode.
- Range: 0 to 255  
Units: Seconds  
Default: 0
- S30 Disconnect Inactivity Timer:** S30 sets how long the modem remains on line with no data flowing. Zero disables the timer.
- Range: 0-255  
Units: Minutes  
Default: 0
- S38 Hang Up Delay Timer:** S38 determines the maximum delay between receipt of the ATH0 command and modem disconnect. .
- Range: 0-255  
Units: Seconds  
Default: 20
- S40 Test Data Pattern:** S40 sets the test pattern to be used by the AT&T4 and AT&T5 commands
- 0 = All Spaces (0)  
1 = A Marks (1)  
2 = Random Data



## XE5690SM REGISTER SETTINGS

**S41 V.34 Symbol Rate:** S41 sets the V.34 test pattern symbol rate to be used by the AT&T4 and AT&T5 commands

- 0 2400 symbols/second 2400-21,600 bps
- 1 2743 symbols/second 4800-26,400 bps
- 2 2800 symbols/second 4800-26,400 bps
- 3 3000 symbols/second 4800-28,800 bps
- 4 3200 symbols/second 4800-31,200 bps
- 5 3429 symbols/second 4800-33,600 bps\*

**S42 Blacklisting** - S42 controls the Blacklisting in the XE5690SM. Blacklisting regulates how frequently the modem can unsuccessfully dial a number. An attempt to dial beyond the limit will result in receipt of the "BLACKLISTED" result code.

- S42 = 0 Disabled
- S42 = 1 Enabled
- Default: 0

**S43 Dial Attempts before Blacklisting** - S44 determines how many dial attempts will be allowed before Blacklisting blocks a call

- Range: 0-4
- Units: Number of Calls
- Default: 4

**S44 Blacklisting Timer** - S44 sets the duration of the Blacklisting period.

- Range: 0-255
- Units: Seconds
- Default: 180

**S50 Minimum Off-Hook Duration** - S50 determines the minimum length of time the modem will remain off-hook. An attempt to drop the line before this timer expires, will be ignored by the modem.

- Range: 0-255
- Units: Seconds
- Default: 3

## XE5690SM User-Registers

The registers described below are controlled by the AT:U command and read with the AT:R command. The user Registers that control the modem's country configuration are described elsewhere in this data sheet.

- U65 Modem Power Down:** U65 permits the XE5690SM to enter power down mode. The modem can only be awakened by applying an active Reset signal to pin 4.  
AT:U65,2008 - Select Powerdown Mode
- U70 Modem Interrupt Register:** U70 allows selects the events that will activate the hardware interrupt line, Pin 3. It also stores the Interrupt status. The interrupts are cleared after this register is read.
- Bit 15- hardware Escape Pin
  - Bit 14- Reserved
  - Bit 13- enables on line escape sequence\*
  - Bit 12- Caller ID activates interrupt
  - Bit 11 - Overcurrent detect initiates interrupt
  - Bit 10- Interrupt on Handset Interrupt\*
  - Bit 9 - Activate interrupt on ring detect\*
  - Bit 8 - Activate interrupt on carrier detect\*
  - Bit 7 - Reserved
  - Bit 6 - Reserved
  - Bit 5 - Reserved
  - Bit 4 - Indicates Caller ID Detected
  - Bit 3 - Indicates Overcurrent Detection
  - Bit 2 - Indicates Handset Interrupt
  - Bit 1 - Indicates Ring Detection
  - Bit 0 - Indicates Carrier Detected
- U77 Auto Disconnect on Handset Interrupt -** U77 bit 11 allows the user to configure the XE5690SM to automatically disconnect on a Handset Interrupt condition.
- Bits 12-15 - Reserved (Bit 14 active)
  - Bit 11 - When set the modem automatically disconnects when on a Handset Interrupt condition. This bit is reset in the default state.
  - Bits 0-10 - Reserved - (bits 2, 3, 4, and 5 are normally set.)
- U78 Handset Interrupt control -** U78 controls when the Handset Interrupt functions will be active.
- Bits 14 -15 -
    - 00 - Handset Interrupt disabled\*
    - 01 - Handset Interrupt disabled during dialing
    - 10 - Handset Interrupt disabled from start of dialing to expiration of Handset Interrupt timer set by bits 0 to 7 of this register
    - 11 - Handset Interrupt disabled until modem negotiations are complete
  - Bits 8-13 - reserved
  - Bits 0-7 - Sets Handset Interrupt timer in 500 millisecond increments. (default = 0)

## **XE5690SM RESPONSES**

<b><u>Digits</u></b>	<b><u>Verbose</u></b>	<b><u>Description</u></b>
0	OK	Command Successful
1	CONNECT	300 bps or higher connection
2	RING	Ring signal detected
3	NO CARRIER	Carrier not detected
4	ERROR	Error in command line
5	CONNECT 1200	1200 bps Connection
6	NO DIAL TONE	No dial tone detected
7	BUSY	Busy signal detected
8	NO ANSWER	Remote does not answer
9	RINGING	Ringback signal detected
10	CONNECT 2400	2400 bps Connection
11	CONNECT 4800	4800 bps Connection
12	CONNECT 9600	9600 bps Connection
14	CONNECT 19,200	19,200 bps Connection
15	CONNECT 7200	7200 bps Connection
16	CONNECT 12000	12,000 bps Connection
17	CONNECT 14400	14,400 bps Connection
18	CONNECT 16800	16,800 bps Connection
19	CONNECT 21600	21,600 bps Connection
20	CONNECT 24000	24,000 bps Connection
21	CONNECT 26400	26,400 bps Connection
22	CONNECT 28,800	28,800 bps Connection
23	CONNECT 31200	31200 bps Connection
24	CONNECT 33600	33,600 bps Connection
30	CIDM	Caller ID Detected
31	FLASH	Hookswitch Flash detected
32	STAS	UK Caller ID Alert detected
33	X	Over current Condition
40	BLACKLIST FULL	The buffer for storing blacklisted numbers is full
41	BLACKLISTED	Attempted Number is Blacklisted
42	NO LINE	No Telephone line is connected to the modem
43	LINE IN USE	The attached Telephone line is in use
52	CONNECT 56000	56,000 bps Connection
60	CONNECT 32000	32,000 bps Connection
61	CONNECT 48000	48,000 bps Connection

## **XE5690SM RESPONSES**

<b><u>Digits</u></b>	<b><u>Verbose</u></b>	<b><u>Description</u></b>
63	CONNECT 28000	28,000 bps Connection
64	CONNECT 29333	29,333 bps Connection
65	CONNECT 30666	30,666 bps Connection
66	CONNECT 33333	33,333 bps Connection
67	CONNECT 34666	34,666 bps Connection
68	CONNECT 36000	36,000 bps Connection
69	CONNECT 37333	37,333 bps Connection
70	PROTOCOL: NONE	No Link Protocol negotiated
77	PROTOCOL V.42	V.42 error correction protocol negotiated
79	PROTOCOL V.42bis	V.42bis data compression protocol negotiated
80	PROTOCOL: ALTERNATE, + CLASS 2	MNP2 error correction negotiated
81	PROTOCOL: ALTERNATE, + CLASS 3	MNP3 error correction negotiated
82	PROTOCOL: ALTERNATE, + CLASS 4	MNP4 error correction negotiated
83	PROTOCOL: ALTERNATE, +CLASS 5	MNP5 error correction negotiated
90	CONNECT 38666	38,666 bps Connection
91	CONNECT 40000	40,000 bps Connection
92	CONNECT 41333	41,333 bps Connection
93	CONNECT 42666	42,666 bps Connection
94	CONNECT 44000	44,000 bps Connection
95	CONNECT 4533	45,333 bps Connection
96	CONNECT 45666	45,666 bps Connection
97	CONNECT 49333	49,333 bps Connection
98	CONNECT 50666	50,666 bps Connection
99	CONNECT 52000	52,000 bps Connection
100	CONNECT 53333	53,333 bps Connection
101	CONNECT 54666	54,666 BPS Connection
102	UN-OBTAINABLE NUMBER	DTMF Dial attempt on Pulse only Line

## FCC Instructions

The XE5690SM complies with Part 68 of the FCC Rules and Regulations. With each device shipped, there is a label which contains the FCC Registration Number. The FCC Registration number incorporates the Model Number, Manufacturer Identifier, Product Type identifier and Ringer Equivalence Number (REN) for this product. You must, upon request, provide this information to your telephone company. the format of the FCC Registration Number is shown below.

***US: DWEMM00BXE5690SM***

The mounting of this device in the final assembly must be made in such a manner as to preserve the high voltage protection between the TIP/RING Connection and the rest of the system. Typically, this may be accomplished by maintaining a minimum spacing 100 mils between the TIP/RING Traces to the RJ-11C Jack and low voltage portion of the system. No additional circuitry may be attached between TIP/RING and the telephone line connection, unless specifically allowed in the rules.

The REN is useful to determine the quantity of devices you may connect to a telephone line and still have all of these devices ring when the number is called. In most, but not all areas, the sum of the RENs of all devices connected to one line should not exceed five (5.0). To be certain of the number of devices you may connect to the line, as determined by the REN, you should contact the local telephone company to determine the maximum REN for you calling area.

If your system causes harm to the telephone network, the telephone company may discontinue service temporarily. If possible, they will notify you in advance. If advance notification is not practical, you will be notified as soon as possible.

Your telephone company may make changes in its facilities, equipment, operations or procedures that could affect proper functioning of your equipment. If they do, you will be notified in advance to give you an opportunity to maintain uninterrupted telephone service.

If you experience trouble with this device, please contact XECOM at (408) 945-6640 for information on obtaining service or repairs. The telephone company may ask you to disconnect this device from the network until the problem has been corrected or until you are sure that the device is not malfunctioning.

---

## Terms of Sale

Devices sold by XECOM are covered by the warranty provisions appearing in its Terms of Sale only. XECOM makes no warranty, express, statutory, implied, or by description regarding the information set forth herein, or regarding the freedom of the described devices from patent infringement. XECOM makes no warranty of merchantability or fitness for any purposes. XECOM reserves the right to discontinue production and change specifications and prices at any time and without notice. This product is intended for use in normal commercial applications. Applications requiring extended temperature range, unusual environmental requirements, or high reliability applications, such as military, medical life-support or life-sustaining equipment, are specifically not recommended without additional processing and authorization by XECOM for such application.

Xecom assumes no responsibility for the use of any circuitry other than circuitry embodied in a Xecom product. No other circuits, patents, or licenses are implied.

## Life Support Policy

Xecom's products are not authorized for use as Critical Components in Life Support Devices or Systems.

**Life Support Devices or Systems** are devices or systems which, (a) are intended for surgical implant into the body, or (b) support or sustain life, and whose failure to perform, when properly used in accordance with instructions provided in the labeling, can be reasonably expected to result in significant injury to the user.

**A Critical Component** is any component of a life support device or system whose failure to perform can be reasonably expected to cause failure of the life support device or system, or to affect its safety or effectiveness.

Copyright, Xecom © 2005

While Xecom, Inc. has made every effort to ensure that the information presented here is accurate, Xecom will not be liable for any damages arising from errors or omission of fact. Xecom reserves the right to modify specifications and/or prices without notice. Product mentioned herein are used for identification purposes only and may be trademarks and/or registered trademarks of their respective companies.

**xecom**<sup>®</sup>

**Xecom Incorporated**  
374 Turquoise Street, Milpitas, CA 95035  
Ph:408-942-2200 Fax:408-942-1346 E-Mail: info@xecom.com

## **X-ON Electronics**

Largest Supplier of Electrical and Electronic Components

*Click to view similar products for [cermetek microelectronics manufacturer](#):*

Other Similar products are found below :

[XE2420G](#)