

1. PVC MOLDED CONNECTOR: PHS-305 (BLACK)
2. PVC FLEXIBLE CORD: H05VV-F 3G0.75MM² (BLACK)
3. ELLIPTIC TIE (BLACK)

NOTE: ALL MATERIALS ARE RoHS COMPLIANCE.

CORD SECTION:

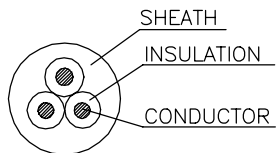

CORD MARKING:

Cabo H05VV-F 3G0.75mm² <VDE> KEMA-KEUR IEMMEQU +++++ <RoVE>
 CE BEC (S) (N) (D) (F) SABS SANS 60227-5 60227 IEC 53 300/500V CE Cn -LF-
 ROLL NO.: 1,2,3...
 CHINA FACTORY

P/NO	POW012-800	TITLE	POWER SUPPLY CORD PHS-305		
		INTERNAL NO:	SP-XXXX-1		
DESIGNED	Wu Haitao 2014.09.12	UNIT	MM	SCALE	FREE
CHECKED		MATERIAL			
APPROVED		PROJECTION			

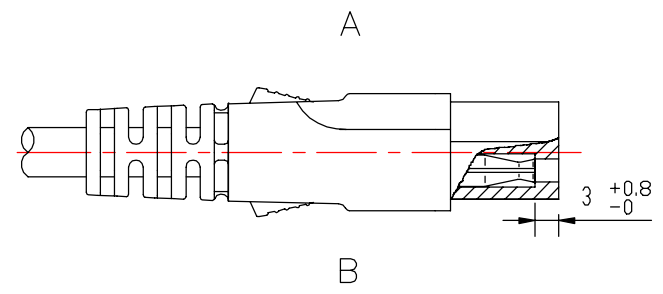
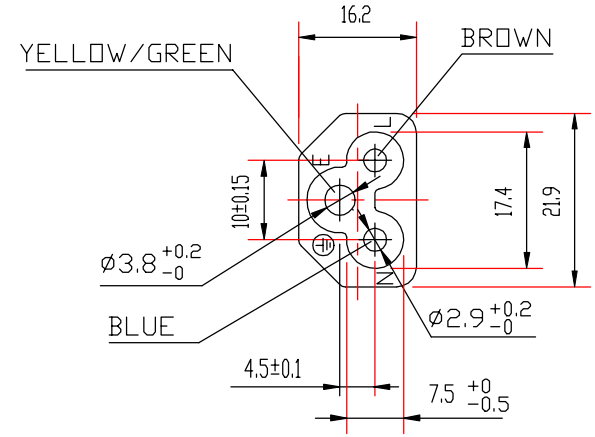
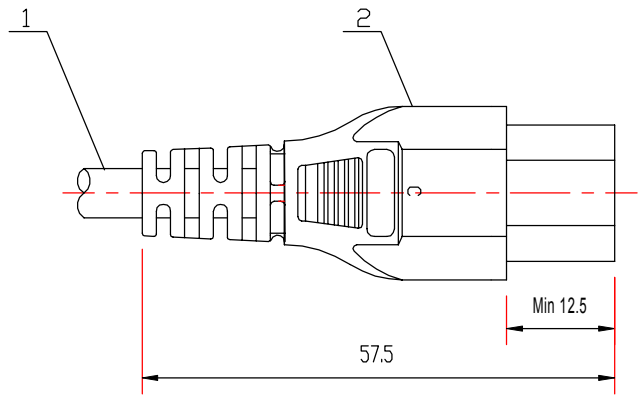

- 1. PVC FLEXIBLE CORD.
- 2. PVC CONNECTOR BODY.

TOLERANCE:
 >20:±2.0
 ≤20:±1.0
 ≤10:±0.5
 ≤1.0:±0.3

SIDE A:

SIDE B:

PHS-305
 2.5A 250V~



MADE IN CHINA

		TITLE	PHS-305		
REVISION		DRAWING NO.			
DESIGNED	Chenguiquan	UNIT	MM	SCALE	
CHECKED		MATERIAL			
APPROVED		PROJECTION			