

1. PVC MOLDED PLUG: PHP-304 (BLACK)
2. PVC FLEXIBLE CORD: GTSA-3 3G0.75MM² (BLACK)
3. ELLIPTIC TIE (BLACK)
4. PVC MOLDED CONNECTOR: PHS-301 (BLACK)

NOTE: ALL MATERIALS ARE RoHS COMPLIANCE.

CORD SECTION:

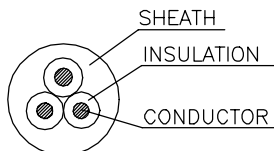

CORD MARKING:

H05VV-F 3G0.75mm² KTL SU01009-5001 60227 IEC 53 300/500V PHINO GTSA-3
 4V-75 V-75(75°C) 250/440V ORDINARY DUTY N18895 201X CE Cn -LF-
 YEAR (eg:2013,2014...) ROLL NO.: 1,2,3... CHINA FACTORY

P/NO	P0W016	TITLE	POWER SUPPLY CORD PHP-304 TO PHS-301		
		INTERNAL NO:	P304-XXXX-1		
DESIGNED	Wu Haitao 2014.09.12	UNIT	MM	SCALE	FREE
CHECKED		MATERIAL			
APPROVED		PROJECTION			

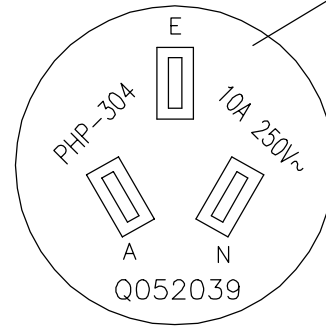
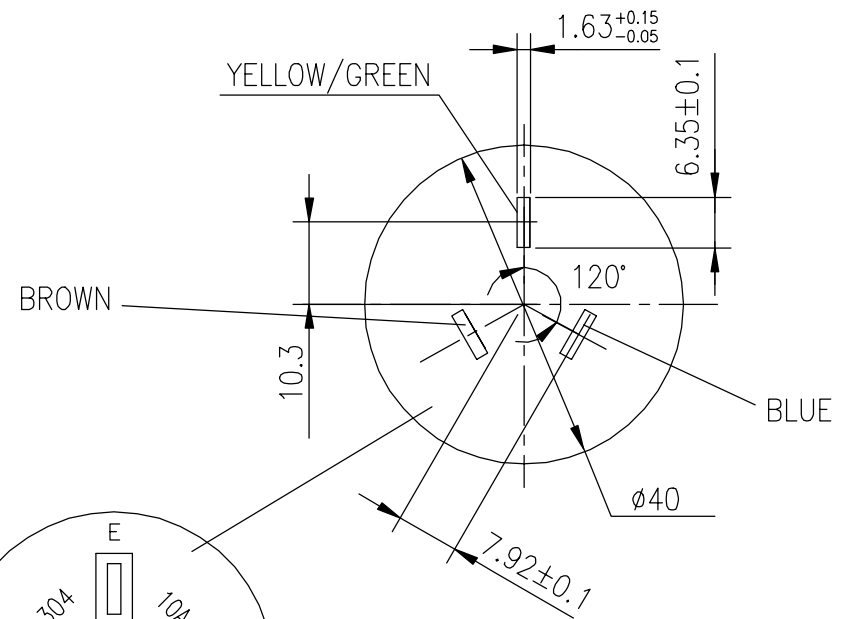
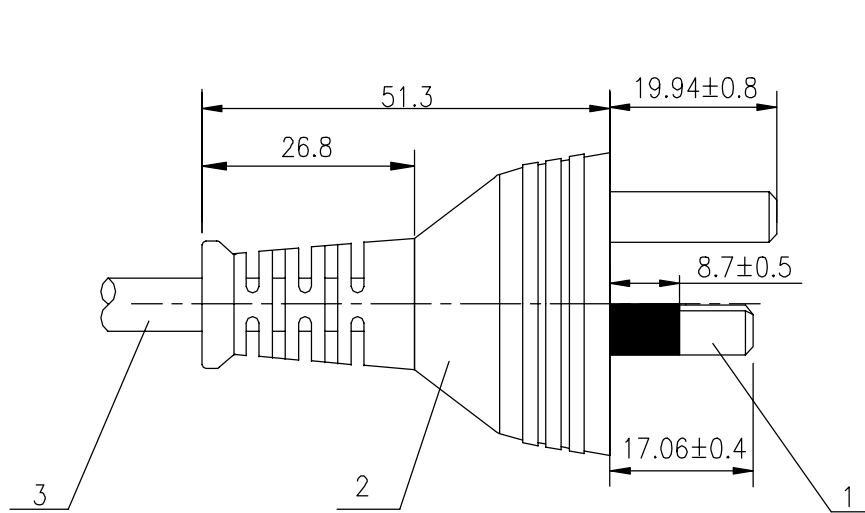

1. PIN(NICKEL PLATING)
2. PVC MOLDED PLUG:PHP-304
3. FLEXIBLE CORD

TOLERANCE:
 >20:±2.0
 ≤20:±1.0
 ≤10:±0.5
 ≤1.0:±0.3

		TITLE	PHP-304		
		DRAWING NO.			
DESIGNED	He Dafeng	UNIT	MM	SCALE	1:1
CHECKED		MATERIAL			
APPROVED		PROJECTION			

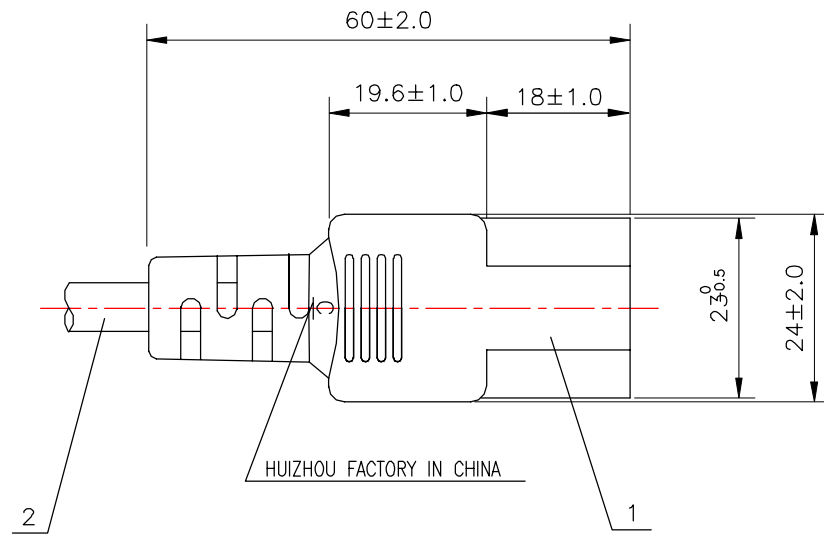

A

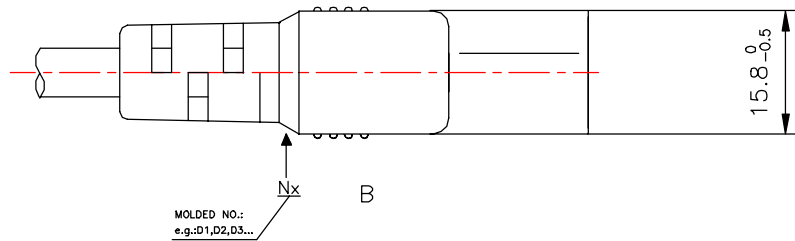

B

SIDE A:

SIDE B:

PHS-301

 N16493
 10A 250V~
 KTL SU04016-2003

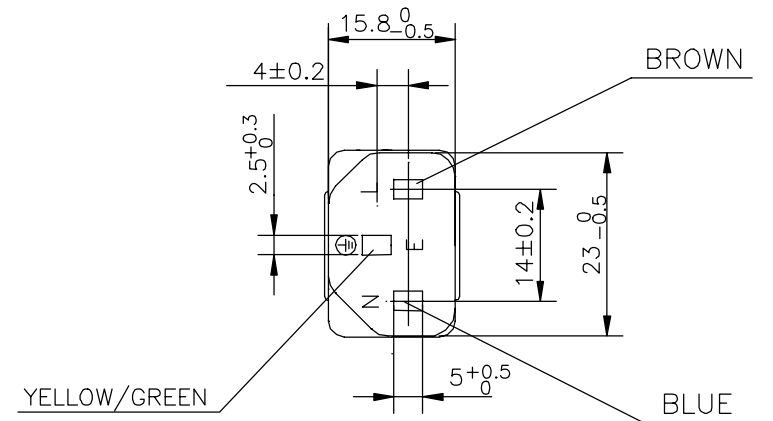

1. PVC CONNECTOR BODY
2. PVC FLEXIBLE CORD

		TITLE	PHS-301		
		DRAWING NO.	FS0150078A		
DESIGNED	PENG LI	UNIT	MM	SCALE	1:1
CHECKED		MATERIAL			
APPROVED		PROJECTION	