

CUSTOMER: 638  
MODEL NO: TEPT-48-241250A

PART NO: \_\_\_\_\_

DATE: AGU-08-2005

DESIGNED NO: FTE-5080583

ASSEMBLY DRAWING:

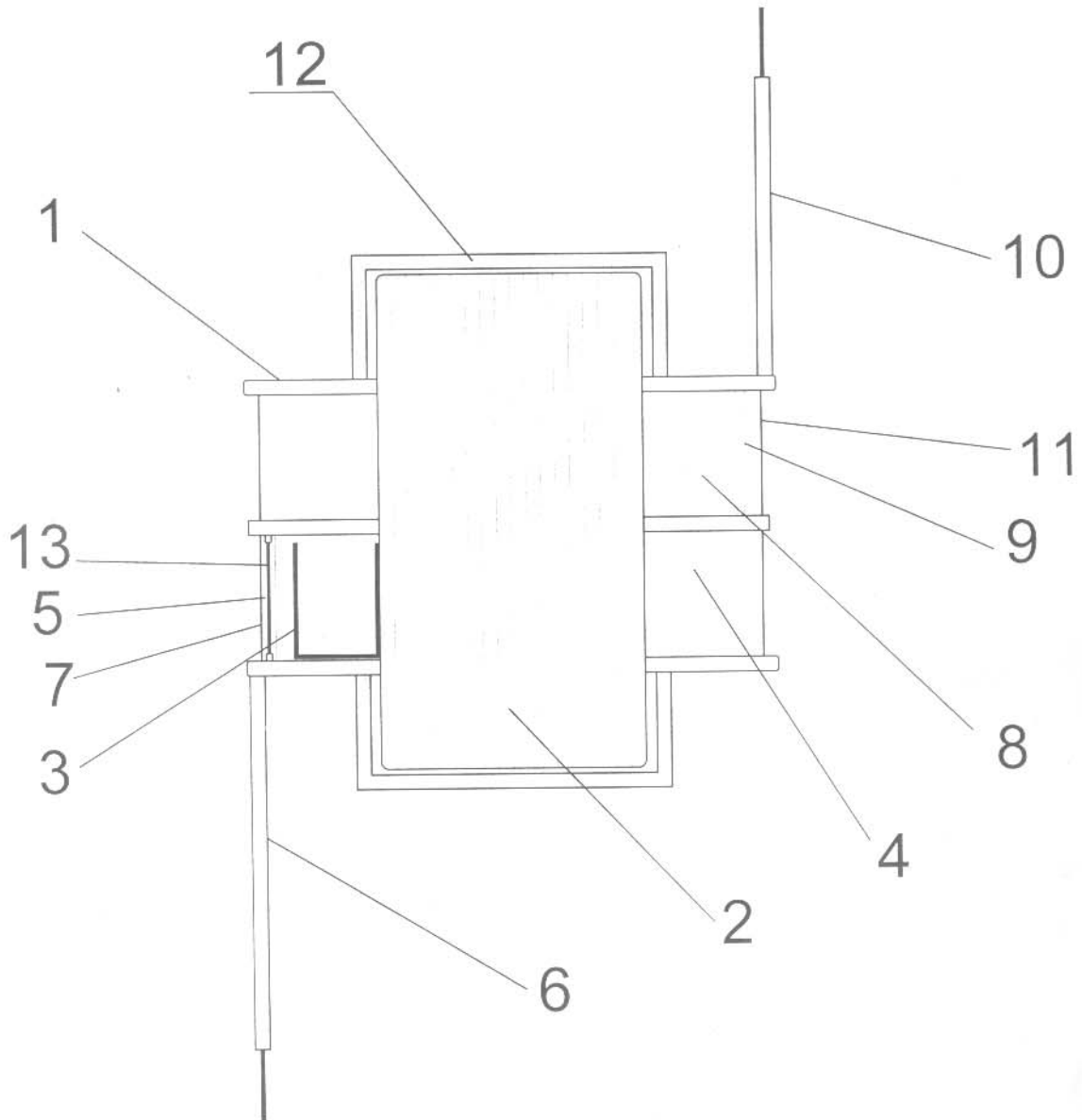

APPROVED BY:

*Handwritten signature*

CHECKED BY:

*Handwritten signature*

PRODUCED BY: 吳馬雲

CUSTOMER: 638

PART NO: \_\_\_\_\_

DATE: AGU-08-2005MODEL NO: TEPT-48-241250ADESIGNED NO: FTE-5080583

NO	DESCRIPTION	MATERIAL	SPEC & QTY	MANUFACTURER
01	Bobbin	Nylon	101L	E. I. Dupont De Nemours (E41938 M) Or Equivalent.
02	Core	Silicon Steel		New Nippon Seitetsu Ind Co., Ltd. Or Kawasaki Steel Corporation Mizushima Works. Or Equivalent.
03	Primary Crossover Insulation	Acetate Cloth Tape	0.36mm 1 Pcs	Duck Sung Tape Co. Ltd. (E105147) Or Equivalent.
04	Primary Winding	Polyurethane Enameled Copper Wire		Feng Ching Metal Corp. <E172395>, Or Wa tai Technical materials Factory (E243939). Or Equivalent.
05	Insulation Between The Primary Winding & Fuse & Lead Wire	Polyester Tape	0.025mm 2 Turns	JingJiang Pressure Sensitive Glue Co., Ltd (E165111N) Or Symbio INC. [Four Pillars Technologies & Applied Materials (Shenzhen) Co., Ltd.] (E50292) Or Equivalent
06	Primary Lead Wire	20AWG 1015	200±10mm	Rei Hsing Wire Co., Ltd (108485) Lu Chiang Electric Wire & Cable Co., Ltd. (E72332) Or Equivalent.
07	Over The Primary Insulation	Polyester Tape  Press Board	0.025mm 2 Turns  0.38 mm 1 Pcs	JingJiang Pressure Sensitive Glue Co., Ltd (E165111N) Or Symbio INC. (Four Pillars Technologies & Applied Materials (Shenzhen) Co., Ltd.) (E50292) HUAHUI Paper & Packing Pruducs Factory Or Equivalent.
08	Secondary Winding	Polyurethane Enameled Copper Wire		Feng Ching Metal Corp. <E172395>, Or Wa tai Elector Technical materials Factory (E243939). Or Equivalent.
09	Insulation Between The Secondary Winding & Lead Wire	Polyester Tape	0.025mm 2 Turns	JingJiang Pressure Sensitive Glue Co., Ltd (E165111N) Or Symbio INC. (Four Pillars Technologies & Applied Materials (Shenzhen) Co., Ltd.) (E50292) Or Equivalent.
10	Secondary Lead Wire	20AWG 1015	200±10mm	Rei Hsing Wire Co., Ltd (108485) Lu Chiang Electric Wire & Cable Co., Ltd. (E72332) Or Equivalent.
11	Over The Secondary Insulation.	Polyester Tape  Press Board	0.025mm 2 Turns  0.38 mm 1 Pcs	JingJiang Pressure Sensitive Glue Co., Ltd (E165111N) Or Symbio INC. (Four Pillars Technologies & Applied Materials (Shenzhen) Co., Ltd.) (E50292) HUAHUI Paper & Packing Pruducs Factory Or Equivalent.
12	Channel Frame & Frame Bottom	Cold Rolled Steel		QIYU Hardware & Plastic Manufactory. Or Equivalent.
13	Thermal Cutoff FUSE	G13, 123 130°C Or 124 133°C Or M33 130°C Or SM129A0 130°C Or A4, P4 130°C	1 Pcs	Uchihashi Estec Co., Ltd (E50082 N) Matsushita Electric Co. Ltd (E60271N) Joint Force Metal Research & Co. (E142267) NEC Corporation. (E71747) Aupo Electronics Ltd. (E140847) Or Equivalent.

PPROVED BY:

胡志榮

CHECKED BY:

胡志榮

PRODUCED BY: 吳馬雲

CUSTOMER: 638

PART NO: \_\_\_\_\_

DATE: AGU-08-2005

MODEL NO: TEPT-48-241250A

DESIGNED NO: FTE-5080583

ITEM	SPEC	SAMPLE				
		1	2	3	4	5
PRIMARY EXCITING CURRENT (1-2) I/P 240VAC 50Hz	40 mA MAX	20.4	21.2	20.3		
PRIMARY LOAD CURRENT (1-2) I/P 240VAC 50Hz	180 mA MAX	155.9	156.5	155.4		
SECONDARY VOLTAGE (3-4) NO LOAD	AC: 30.0V MAX	29.02	29.04	29.05		
SECONDARY VOLTAGE (3-4) LOAD AC:1.25A	AC: 24.0V ±5%	24.04	24.05	24.11		
SECONDARY VOLTAGE NO LOAD	V					
SECONDARY VOLTAGE LOAD:	V					
SECONDARY VOLTAGE NO LOAD	V					
SECONDARY VOLTAGE LOAD:	V					
HI-POT	PRI. TO SEC-CORE	4500V/1Minute	OK	OK	OK	
	SEC. TO CORE	1200V/1Minute	OK	OK	OK	

APPROVED BY:

*胡志華*

CHECKED BY:

*胡志華*

TESTED BY: 吳馬雲