

7916 Series

H.D. D-SUB Right Angle Type

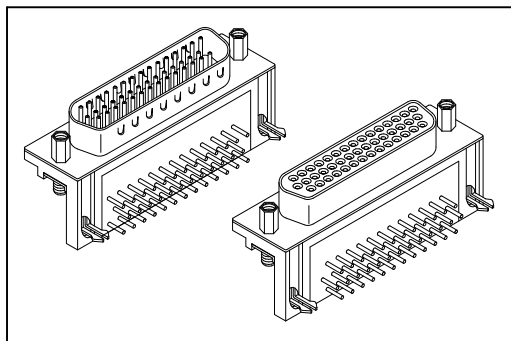

Material:

Housing: Thermoplastic Polyester Glass Filled UL94V-0.

Contacts: Copper Alloy.

Shell: Metal.

Electrical Characteristics:

Current Rating: 1 A.

Dielectric Withstanding Voltage: AC 1000V.

Insulator Resistance: 1000MΩ min.

Contact Resistance: 30mΩ max.

Operating Temperature: -55°C~+105°C.

Features:

* Mates with: 7917, 7918.

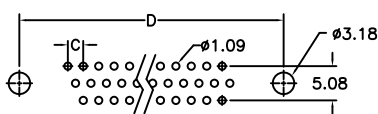
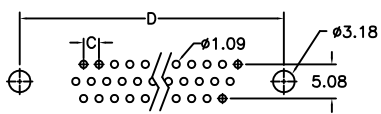
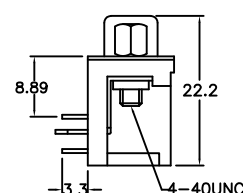
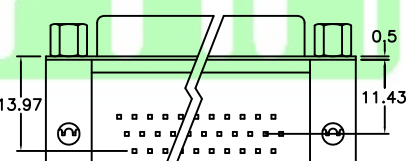
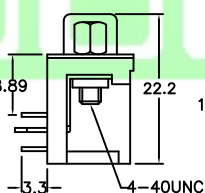
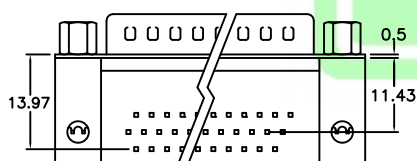
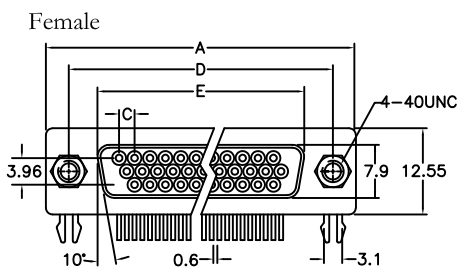
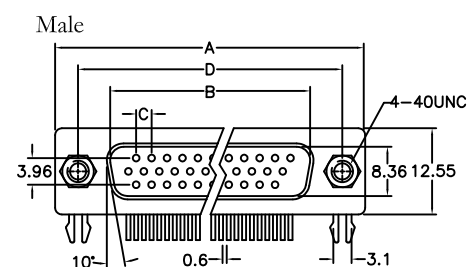

Position	Dimension				
	A	B	C	D	E
15	30.81	16.92	2.29	24.99	16.33
26	39.14	25.25	2.29	33.32	24.66
44	53.04	38.96	2.29	47.04	38.38
62	69.32	55.42	2.41	63.50	54.84

Ordering information

7916-

Series

62

Position

F

M: Male
F: Female

A

A ~ Z: See Page A152 ~ A153

A

A: Tray Package

Mounting Option

Footprint 8.07mm(0.318")



Option A

With Grounding Forks (Locking Type) and With Jack Screws Attached.

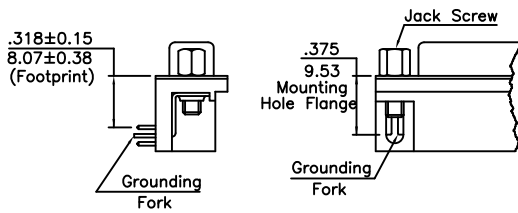

Option G

With Grounding Forks (Locking Type) and With .125 Diameter Non-threaded Riveted Inserts.

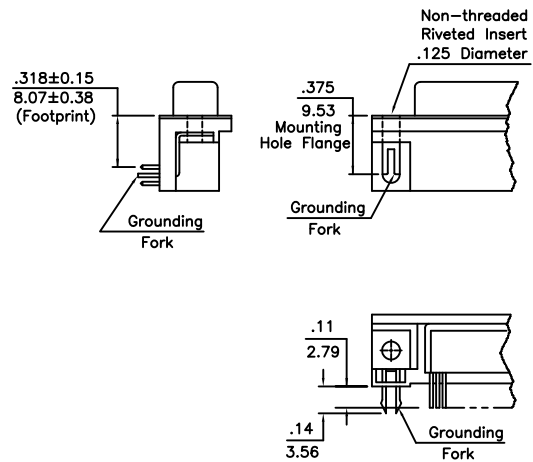

Option B

With Grounding Forks (Locking Type) and With Riveted Threaded Inserts.

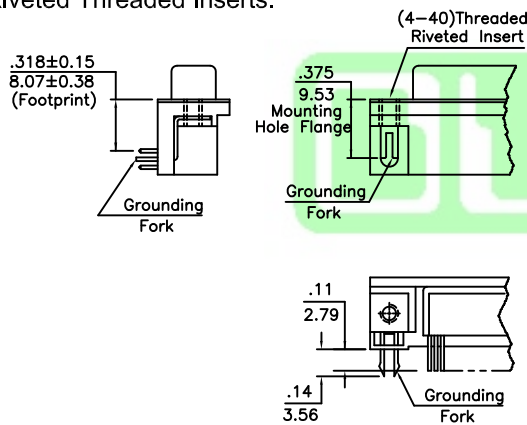

Option H1

With Riveted Threaded Inserts and With Jack Screw Attached.

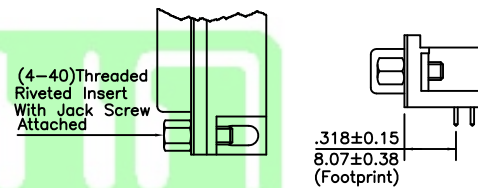

Option B1

With Riveted Threaded Inserts.

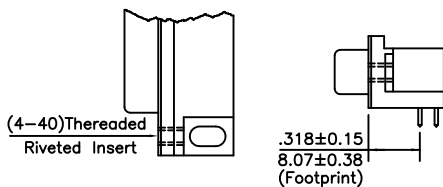

Option K

Grounding Strap With .125 Diameter Non-threaded Mounting Holes. and With Riveted Threaded Inserts.

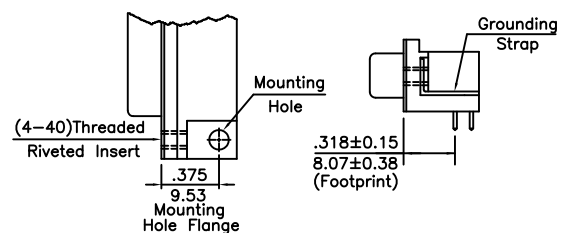

Mounting Option

Footprint 8.07mm(0.318")



Option L1

With .125 Diameter Non-threaded Mounting Holes. and With Riveted Threaded Inserts and With Jack Screws Attached.

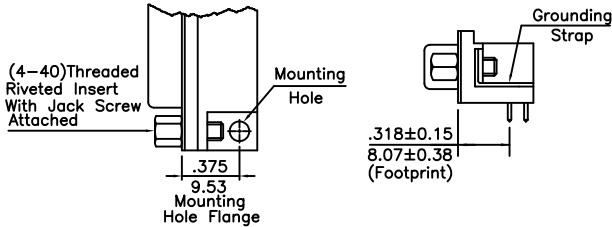

Option Y

With Grounding Forks (Locking Type) With Riveted Threaded Inserts and With Jack Screws Attached.

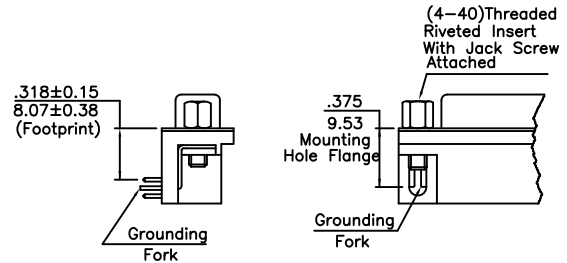

Option L

Same As Option L1, but Jack Screws Are Bagged Separately.

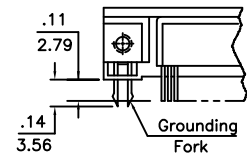
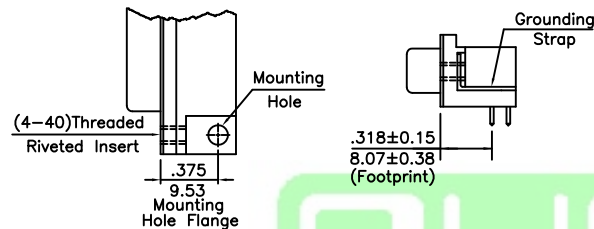

Option H

Same As Option Y, but Jack Screws Are Bagged Separately.

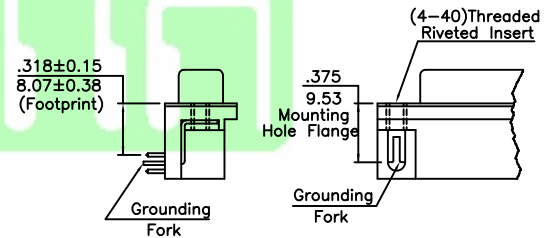
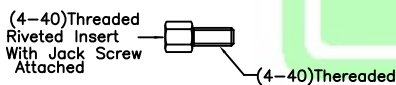

Option Q

With .130 Diameter Non-threaded Mounting Holes. and With Jack Screws Attached.

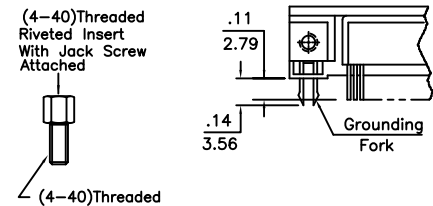
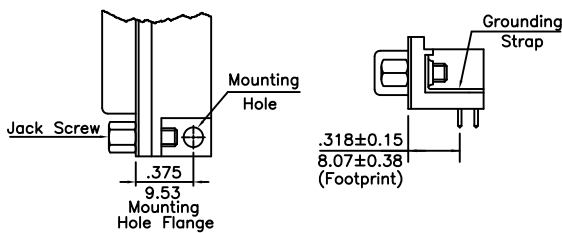

Option R

Grounding Strap With .125 Diameter Non-threaded Mounting Holes. and With .125 Diameter Non-threaded Riveted Inserts.

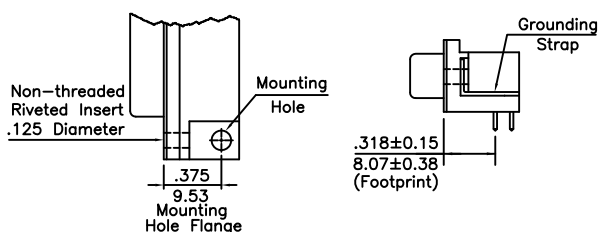

Option Z

With 4-40 Threaded Mounting Holes. and With Jack Screws Attached and With .130 Diameter Riveted Inserts.

