

Magnetic Transducer

SMT13 series

DIMENSIONS

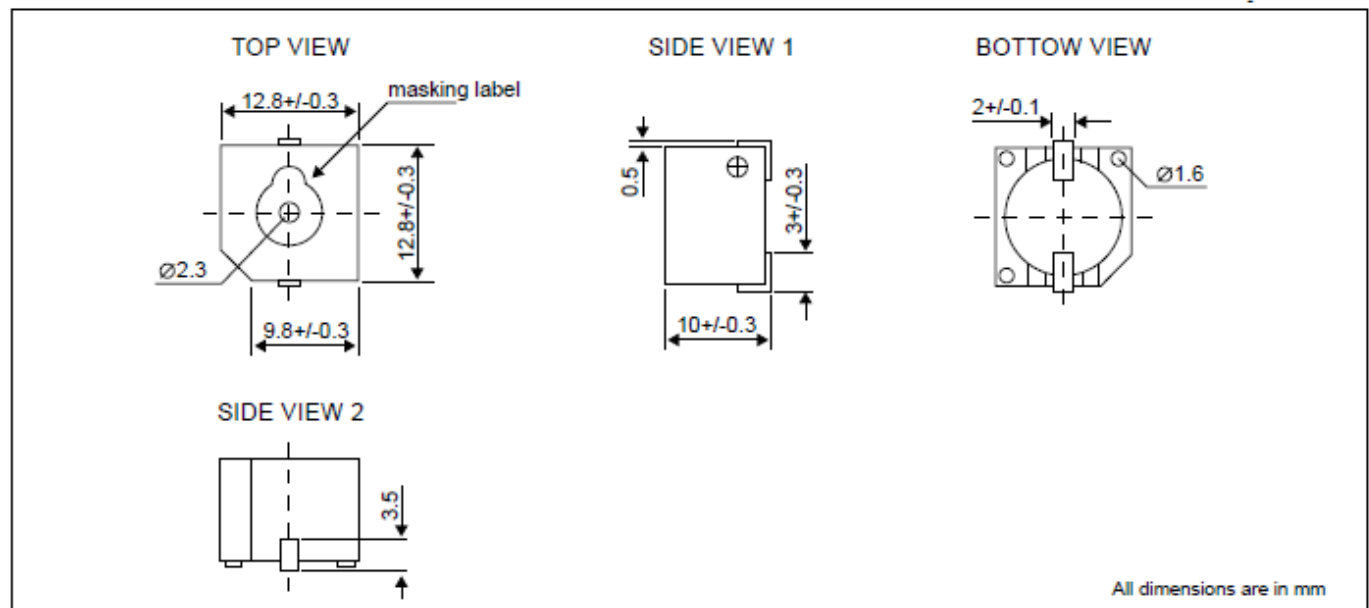

Ref. no. : GS021-R

Remark : Kapton label



ELECTRICAL SPECIFICATIONS

Model No.		MT13-D5CPSR
Operating Voltage	[V]	3 ~ 8
Rated Voltage	[V]	5
* Max. Rated Current	[mA]	40
Coil Resistance	[ohm]	47 +/- 5
# Coil Impedance	[ohm]	80
* Min. Sound Output	[dBA /10cm]	90
Resonant Frequency	[Hz]	2400
Operating Temperature	[°C]	-40 ~ +85
Terminal		SMD
Housing Material		PPS
Colour		Grey
Weight	[gm]	2

Value applying [resonant frequency, sine wave, measuring current 60uA]

* Value applying rated voltage [resonant frequency, 1/2 duty, square wave] and recommended circuit [HFE >200, min.2.5mA]