

External Drive Piezo Transducer

SPT03 series

DIMENSIONS

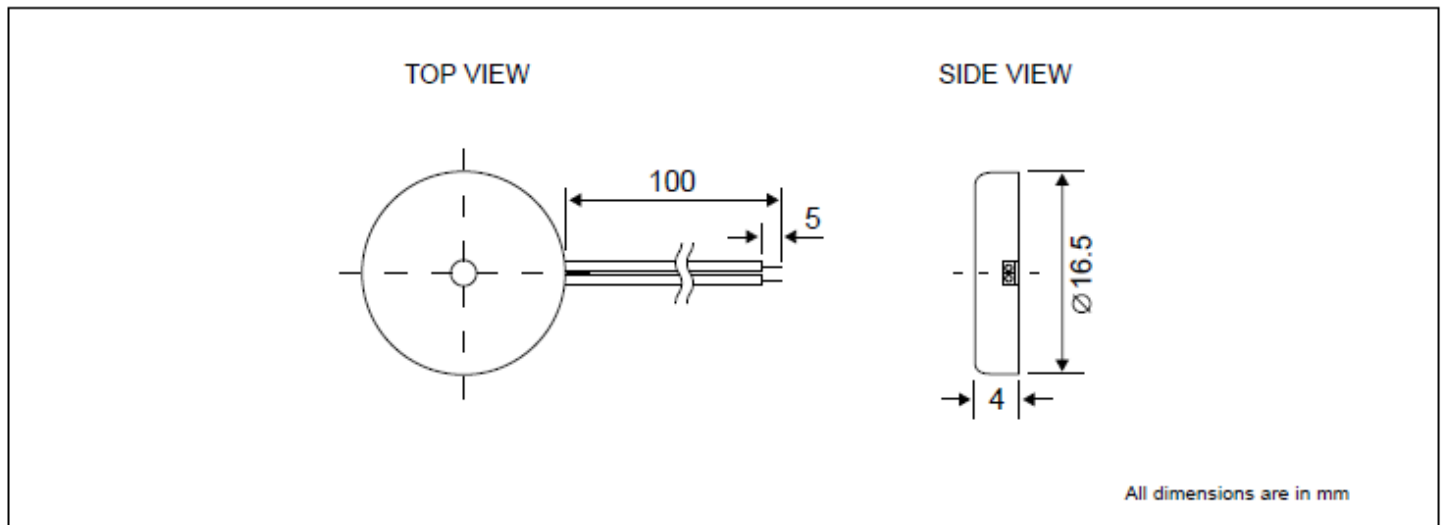

Ref. no. : QS002



ELECTRICAL SPECIFICATIONS

Model No.	PT03-170440AWR
Sound Pressure Level	80 dBA min. [3 Vrms Sine Wave, 10cm, 4000Hz]
Capacitance	13000 pF +/- 30% at 1KHz
Max. Input Voltage	30V p-p
Operating Temperature [°C]	-20 ~ +70
Terminal	Wire - UL1571 AWG#30
Housing Material	ABS
Housing Colour	Black
Weight [gm]	1