

External Drive Piezo Transducer

SPT26 series

DIMENSIONS

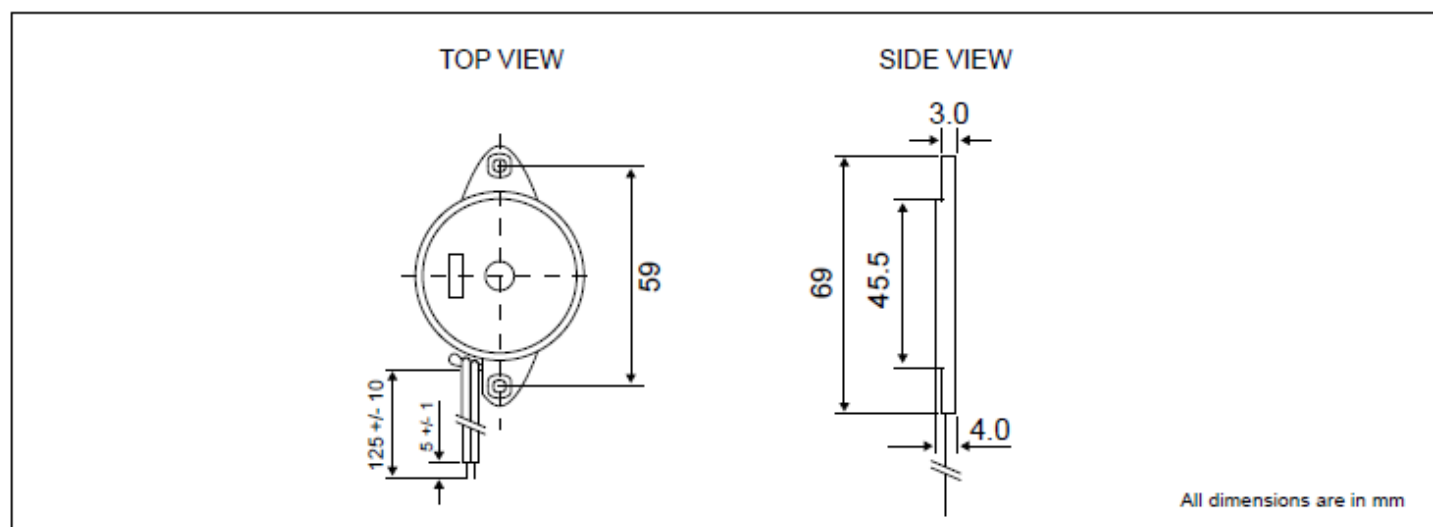

Ref. no. : PC002NK-R

Remark : RoHS compliance

ELECTRICAL SPECIFICATIONS

Model No.	PT26-450412AWR
Sound Pressure Level	80 dBA min. [12 V p-p Square Wave, 30cm, 1200Hz]
Capacitance	66000 pF +/- 30% at 120Hz
Max. Input Voltage	30 V p-p
Operating Temperature [°C]	-20 ~ +60
Terminal	Wire
Housing Material	ABS
Housing Colour	Black
Weight [gm]	7