

TO-220AK Plastic-Encapsulate Thyristors

BTA24 3Q TRIACs

MAIN CHARACTERISTICS

$I_{T(RMS)}$		25A
V_{DRM}/V_{RRM}	BTA24-600(C/B)W	600V
	BTA24-800(C/B)W	800V
V_{TM}		1.55V

FEATURES

- NPNPN 5-layer Structure TRIACs
- Mesa Glass Passivated Technology
- Multi Layers Metal Electrodes
- High Junction Temperature
- Good Commutation Performance
- High dV/dt and dI/dt
- Insulating Voltage=2500V_(RMS)

APPLICATIONS

- Heater Control
- Motor Speed Controller
- Mixer

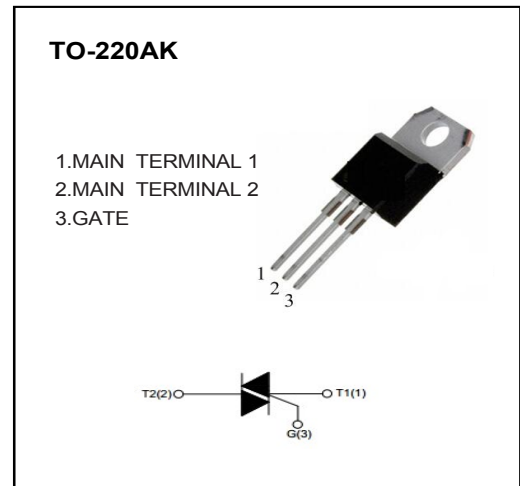

MARKING

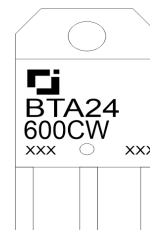

BTA24:Series Code
600CW:Depends on V_{DRM}
and IGT
XXX:Internal Code

ABSOLUTE RATINGS ($T_a=25^\circ\text{C}$ unless otherwise noted)

Symbol	Parameter	Test condition	Value	Unit	
V_{DRM}/V_{RRM}	Repetitive peak off-state voltage	$T_j=25^\circ\text{C}$	BTA24-600(C/B)W	600	V
			BTA24-800(C/B)W	800	V
$I_{T(RMS)}$	RMS on-state current	TO-220AK($T_c \leq 75^\circ\text{C}$), Fig. 1,2	25	A	
I_{TSM}	Non repetitive surge peak on-state current	Full sine wave, $T_j(\text{init})=25^\circ\text{C}$, $t_p=20\text{ms}$; Fig. 3,5	250	A	
I^2t	I^2t value	$t_p=10\text{ms}$	340	A ² s	
dI_T/dt	Critical rate of rise of on-state current	$I_G=2 \cdot I_{GT}$, $t_r \leq 10\text{ns}$, $F=120\text{Hz}$, $T_j=125^\circ\text{C}$	I - II - III	50	A/ μs
I_{GM}	Peak gate current	$t_p=20\mu\text{s}$, $T_j=125^\circ\text{C}$	4	A	
$P_{G(AV)}$	Average gate power	$T_j=125^\circ\text{C}$	1	W	
T_{STG}	Storage temperature		-40~+150	°C	
T_j	Operating junction temperature		-40~+125		

ELECTRICAL CHARACTERISTICS (T_a=25°C unless otherwise specified)

Symbol	Parameter	Test condition	Value		Unit	
			CW	BW		
I _{GT}	Gate trigger current	V _D =12V, R _L =33Ω, T _j =25°C, Fig. 6	I - II - III	≤35	≤50	mA
V _{GT}	Gate trigger voltage	T _j =25°C, Fig. 6	I - II - III	≤1.3		V
V _{GD}	Non-triggering gate voltage	V _D =V _{DRM} , T _j =125°C		≥0.2		V
I _H	Holding current	I _T =500mA, Fig. 6		≤50	≤75	mA
I _L	Latching current	I _G =1.2I _{GT} , Fig. 6	I - III	≤60	≤80	mA
			II	≤80	≤90	mA
dV _D /dt	Critical rate of rise of off-state	V _D =67%V _{DRM} , Gate Open T _j =125°C		≥500	≥1000	V/μs
V _{TM}	On-state Voltage	I _{TM} =35A, t _p =380μs, Fig. 4		≤1.55		V
I _{DRM} / I _{RPM}	Repetitive peak off-state current	V _D =V _{DRM} /V _{RPM} , T _j =25°C		≤5	≤5	μA
		V _D =V _{DRM} /V _{RPM} , T _j =125°C		≤2.0	≤2.0	mA

THERMAL RESISTANCES

Symbol	Parameter	Value	Unit
R _{th} (j-c)	Junction to case (AC)	TO-220AK	1.7 °C/W
R _{th} (j-a)	Junction to ambient	TO-220AK	60 °C/W

PART NUMBER

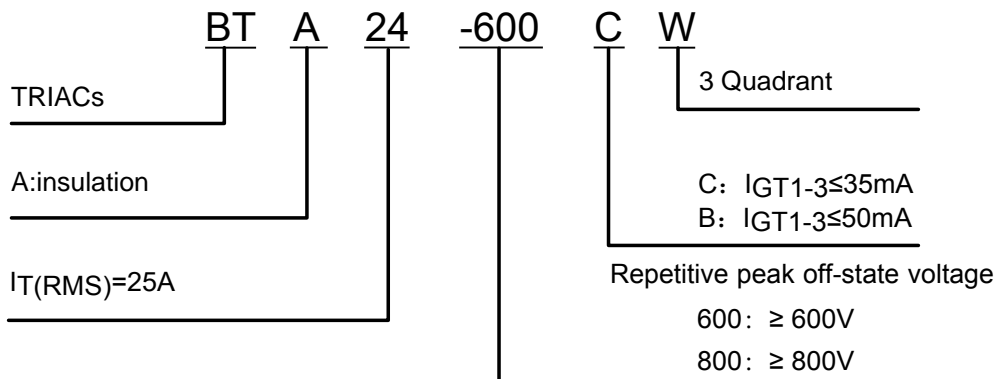

CHARACTERISTICS CURVES

FIG.1: Maximum power dissipation versus RMS on-state current (full cycle)

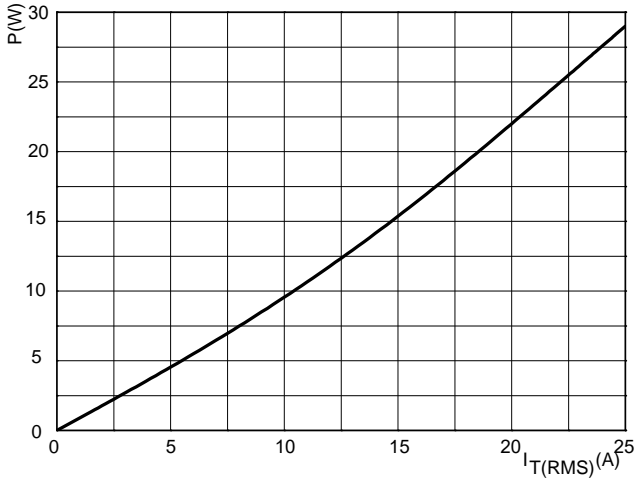

FIG.2: RMS on-state current versus case temperature (full cycle)

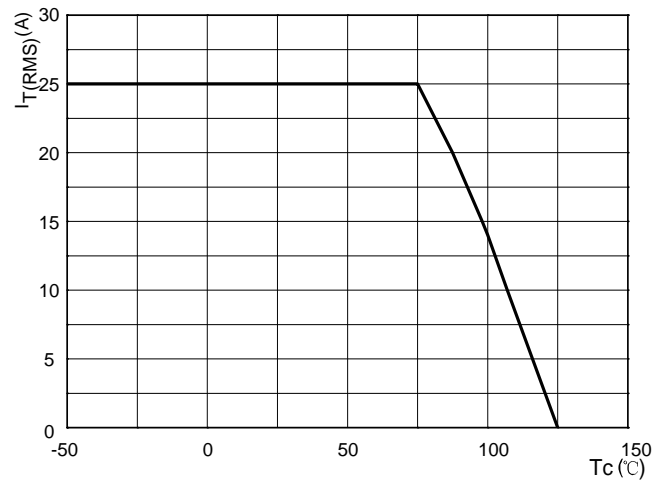

FIG.3: Surge peak on-state current versus number of cycles

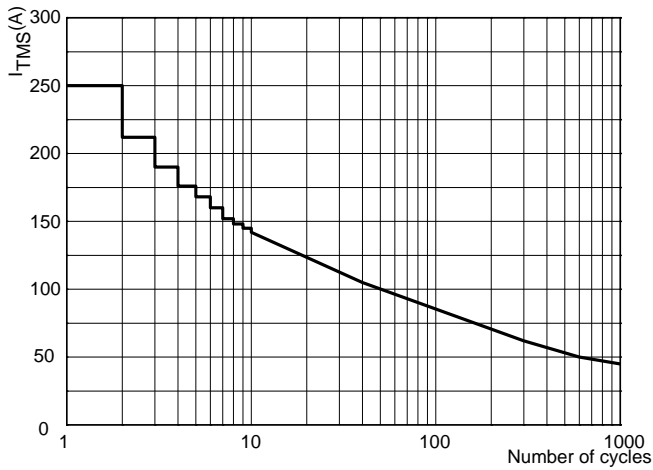

FIG.4: On-state characteristics (maximum values)

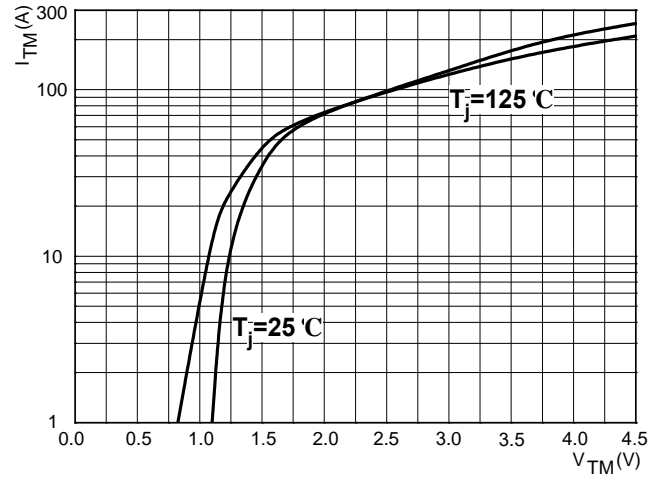

FIG.5: Non-repetitive surge peak on-state current for a sinusoidal pulse with width $t_p < 10ms$

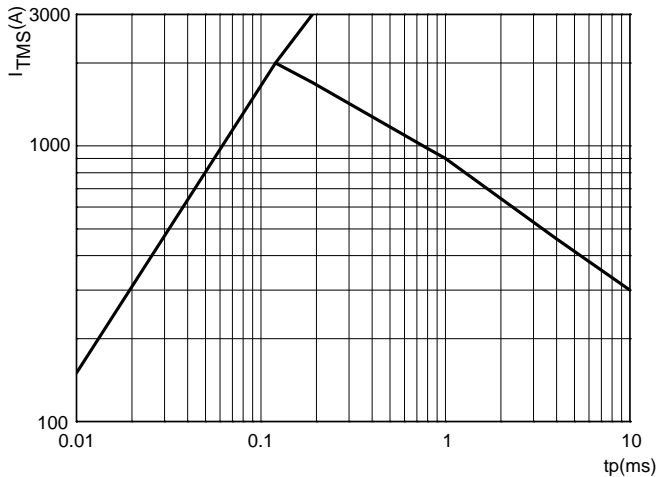
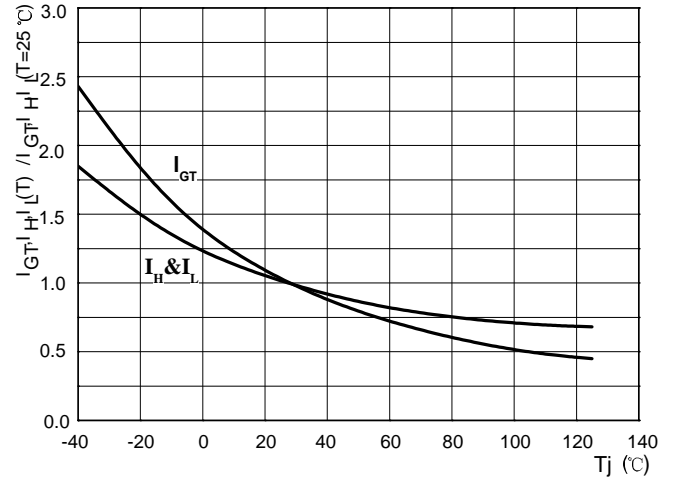
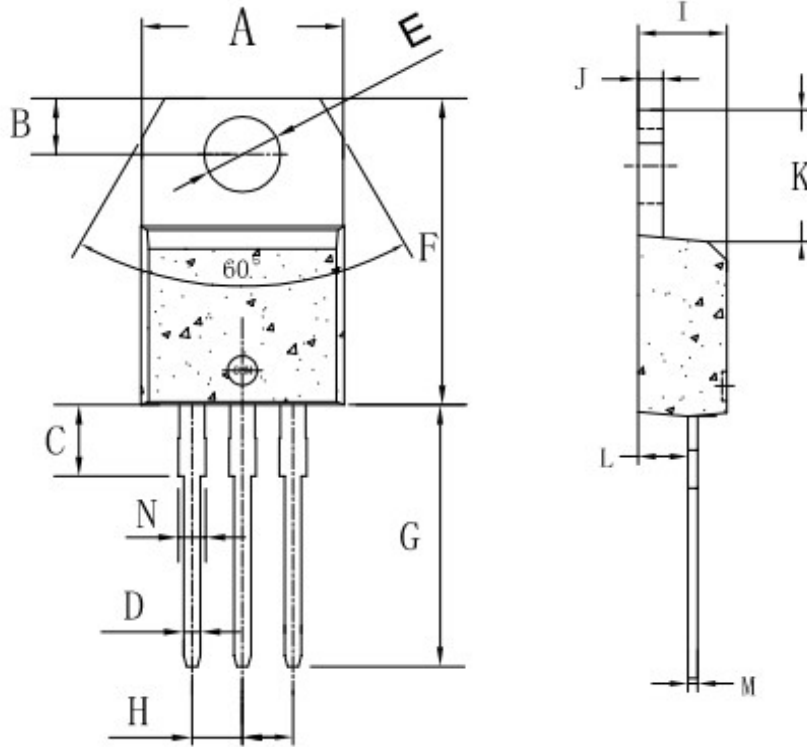

FIG.6: Relative variations of gate trigger current, holding current and latching current versus junction temperature (typical values)



TO-220AK PACKAGE OUTLINE DIMENSIONS



Symbol	Dimensions In Millimeters		Dimensions In Inches	
	Min	Max	Min	Max
A	9.8	10.4	0.385	0.409
B	2.65	3.1	0.104	0.122
C	2.8	4.2	0.110	0.165
D	0.7	0.92	0.027	0.036
E	3.75	3.95	0.147	0.155
F	14.8	16.1	0.582	0.633
G	13.05	13.6	0.513	0.535
H	2.4	2.7	0.094	0.106
I	4.38	4.61	0.172	0.181
J	1.15	1.36	0.045	0.053
K	5.85	6.82	0.230	0.268
L	2.35	2.75	0.092	0.108
M	0.35	0.65	0.013	0.025
N	1.18	1.42	0.046	0.055

X-ON Electronics

Largest Supplier of Electrical and Electronic Components

Click to view similar products for [Triacs](#) category:

Click to view products by [Changjiang](#) manufacturer:

Other Similar products are found below :

[T2035H-6G](#) [BT137-600-0Q](#) [Z0409MF0AA2](#) [Z0109NA 2AL2](#) [ACST1635T-8FP](#) [BCR20RM-30LA#B00](#) [CMA60MT1600NHR](#) [NTE5611](#)
[NTE5612](#) [NTE5613](#) [NTE5621](#) [NTE5623](#) [NTE5629](#) [NTE5638-08](#) [NTE5688](#) [NTE5689](#) [NTE5690](#) [T1235T-8I](#) [BTA312-600CT.127](#) [T1210T-](#)
[8G-TR](#) [Z0109NN0,135](#) [T2535T-8I](#) [T2535T-8T](#) [TN4050-12WL](#) [MAC4DLM-1G](#) [BT137-600E,127](#) [BT137X-600D](#) [BT148W-600R,115](#)
[BT258-500R,127](#) [BTA08-800BW3G](#) [BTA140-800,127](#) [BTA30-600CW3G](#) [BTA30-600CW3G](#) [BTB08-800BW3G](#) [BTB16-600CW3G](#)
[BTB16-600CW3G](#) [Z0410MF0AA2](#) [Z0109MN,135](#) [T825T-6I](#) [T1635T-6I](#) [T1220T-6I](#) [NTE5638](#) [TYN612MRG](#) [TYN1225RG](#) [TPDV840RG](#)
[ACST1235-8FP](#) [ACS302-6T3-TR](#) [BT134-600D,127](#) [BT134-600G,127](#) [BT136X-600E,127](#)