



**CJ431K Adjustable Reference Source**

**CJ431K** Adjustable Accurate Reference Source

**FEATURES**

- The output voltage can be adjusted to 36V
- Low dynamic output impedance ,its typical value is 0.2Ω
- Trapping current capability is 1 to 100mA
- The typical value of the equivalent temperature factor in the whole temperature scope is 50 ppm/°C
- The effective temperature compensation in the working range of full temperature
- Low output noise voltage
- Fast on-state response
- ESD protected up to 2KV

**Equivalent Circuit**

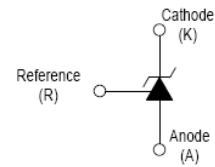

**PIN CONNENCTIONS and MARKING**

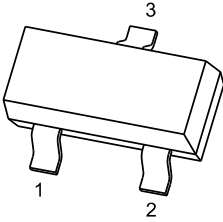
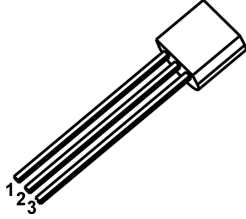
<p><b>CJ431K</b></p> 	<p><b>SOT -23</b></p> <p>1.REFERENCE 2.CATHODE 3. ANODE</p>
<p><b>CJ431K</b></p> 	<p><b>TO-92</b></p> <p>1.REFERENCE 2.ANODE 3.CATHODE</p>

## ORDERING INFORMATION

Part Number	MARKING <sup>(1)</sup>	Package	Packing Method	Pack Quantity
CJ431K	431K •	SOT-23	Reel	3000pcs/Reel
CJ431K	CJ <sup>(2)</sup> TL431K • XXX	TO-92	Bulk	1000pcs/Bag
CJ431K-TA	CJ <sup>(2)</sup> TL431K • XXX	TO-92	Tape	2000pcs/Box

Notes:(1).Solid dot=Green molding compound device,if none,the normal device.

(2).XXX=Code

## ABSOLUTE MAXIMUM RATINGS (Operating temperature range applies unless otherwise specified)

Parameter	Symbol	Value	Units
Cathode Voltage	$V_{KA}$	37	V
Cathode Current Range (Continuous)	$I_{KA}$	-100~+150	mA
Reference Input Current Range	$I_{ref}$	0.05~+10	mA
Power Dissipation	$P_D$	770	mW
Thermal Resistance from Junction to Ambient	$R_{\theta JA}$	162	°C/W
Operating temperature	$T_{opr}$	-25~+125	°C
Junction Temperature	$T_J$	150	°C
Storage Temperature Range	$T_{stg}$	-65~+150	°C

## ELECTRICAL CHARACTERISTICS (Ta=25°C unless otherwise specified)

Parameter	Symbol	Test conditions	Min	Typ	Max	Unit
Reference input voltage	$V_{ref}$	$V_{KA}=V_{REF}, I_{KA}=10mA$	2.470		2.520	V
Deviation of reference input voltage over temperature (note)	$\Delta V_{ref}/\Delta T$	$V_{KA}=V_{REF}, I_{KA}=10mA$ $T_{min} \leq T_a \leq T_{max}$		4.5	17	mV
Ratio of change in reference Input voltage to the change in cathode voltage	$\Delta V_{ref}/\Delta V_{KA}$	$I_{KA}=10mA$	$\Delta V_{KA}=10V \sim V_{REF}$	-1.0	-2.7	mV/V
			$\Delta V_{KA}=36V \sim 10V$	-0.5	-2.0	mV/V
Reference input current	$I_{ref}$	$I_{KA}=10mA, R_1=10k\Omega$ $R_2=\infty$		1.5	4	$\mu A$
Deviation of reference input current over full temperature range	$\Delta I_{ref}/\Delta T$	$I_{KA}=10mA, R_1=10k\Omega$ $R_2=\infty$ $T_A=-25$ to $125^\circ C$		0.4	1.2	$\mu A$
Minimum cathode current for regulation	$I_{KA(min)}$	$V_{KA}=V_{REF}$		0.45	1.0	mA
Off-state cathode current	$I_{KA(OFF)}$	$V_{KA}=40V, V_{REF}=0$		0.05	0.5	$\mu A$
Dynamic impedance	$Z_{KA}$	$V_{KA}=V_{REF}, I_{KA}=1$ to $100mA$ $f \leq 1.0kHz$		0.15	0.5	$\Omega$

Note:  $T_{MIN}=-25^\circ C, T_{MAX}=+125^\circ C$

## CLASSIFICATION OF $V_{ref}$

Rank	0.5%	1%
Range	2.482-2.508	2.47-2.52

# Typical Characteristics

**Cathode Current versus Cathode Voltage**

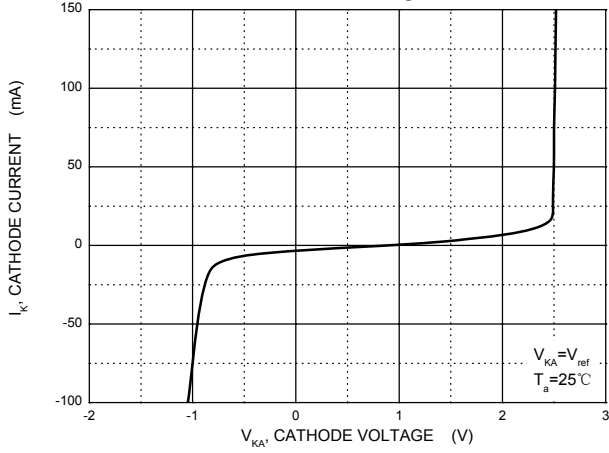

**Cathode Current versus Cathode Voltage**

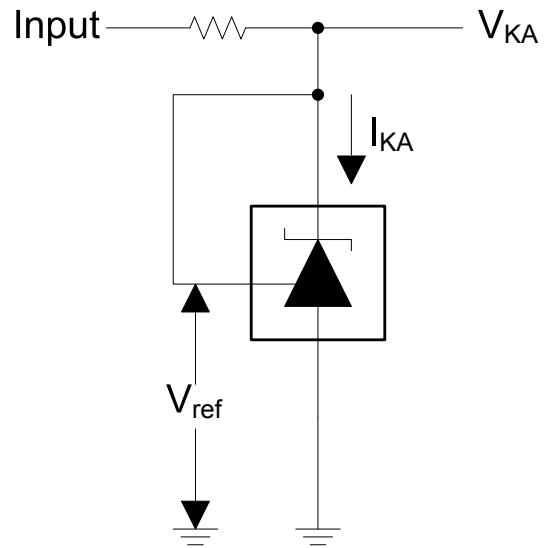
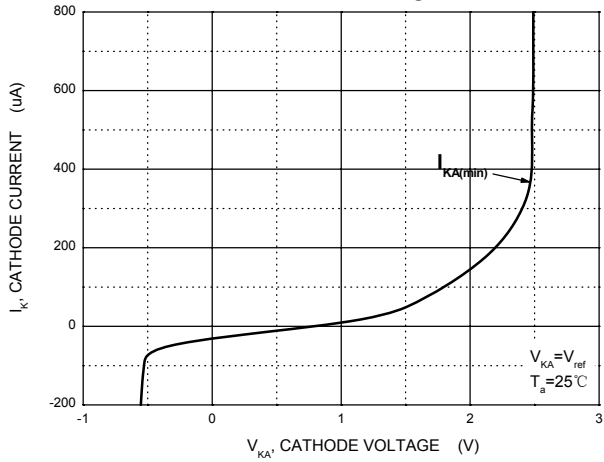

Test Circuit for  $V_{KA} = V_{ref}$

**Reference Input Voltage versus Ambient Temperature**

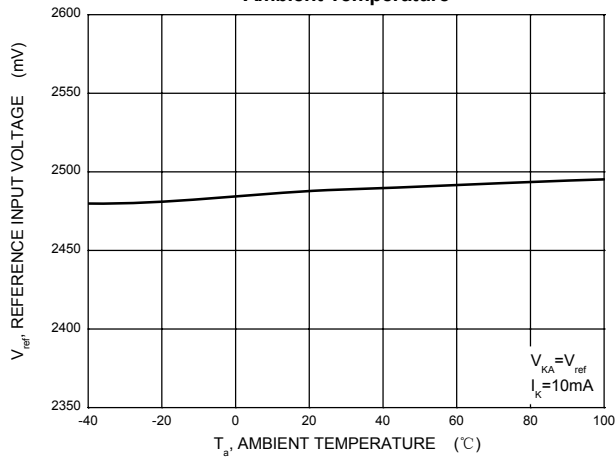

# Typical Characteristics

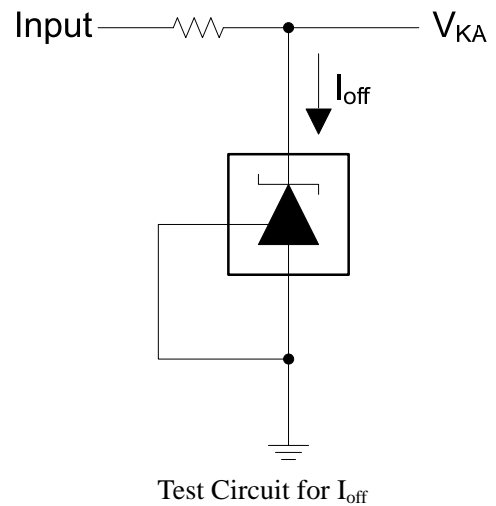
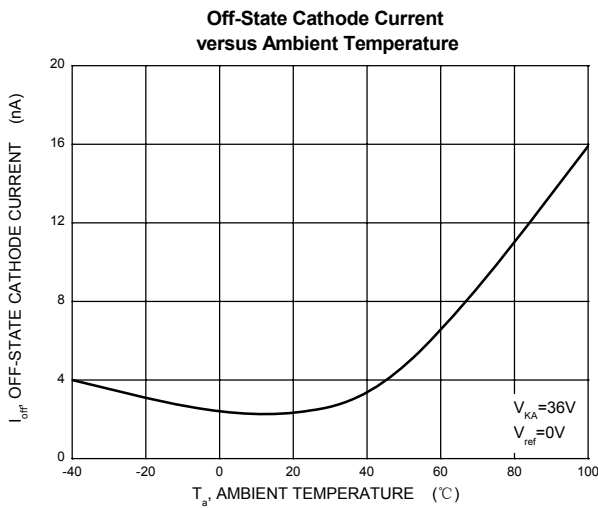
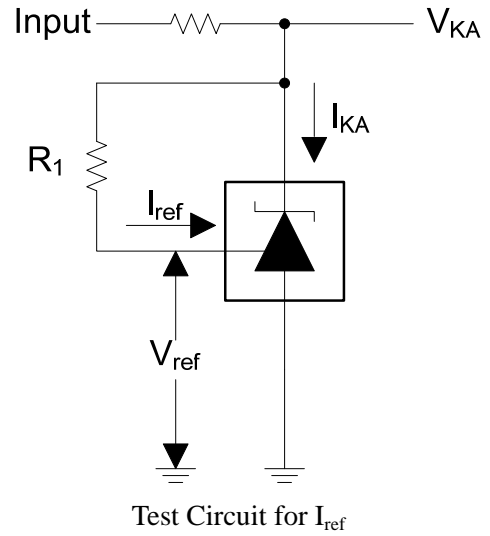
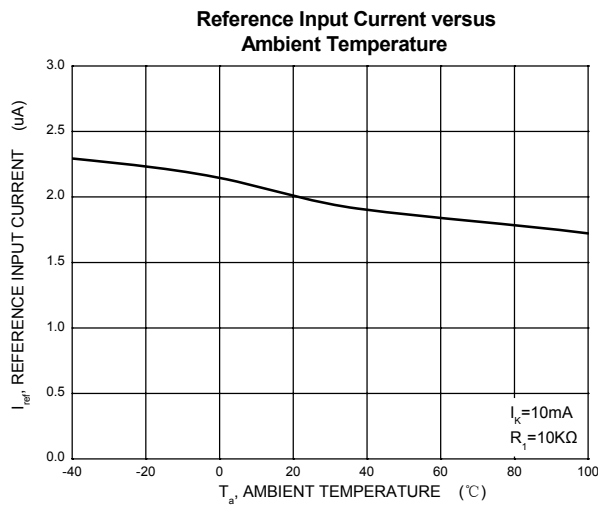
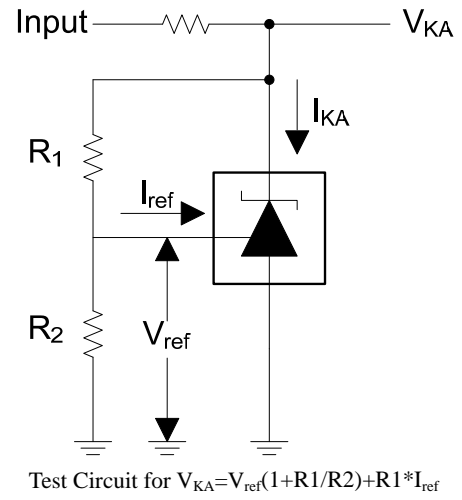
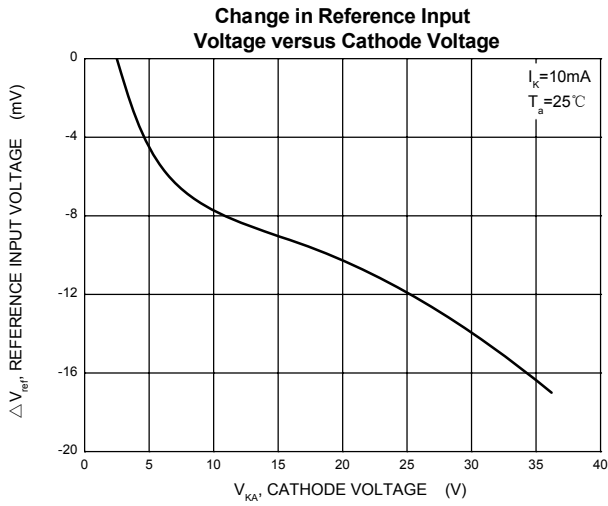

## TO-92 Package Outline Dimensions

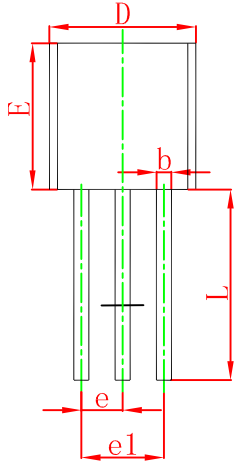
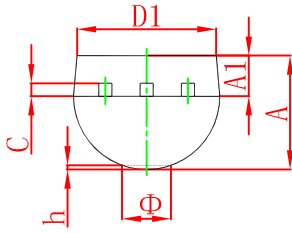

Symbol	Dimensions In Millimeters		Dimensions In Inches	
	Min	Max	Min	Max
A	3.300	3.700	0.130	0.146
A1	1.100	1.400	0.043	0.055
b	0.380	0.550	0.015	0.022
c	0.360	0.510	0.014	0.020
D	4.300	4.700	0.169	0.185
D1	3.430		0.135	
E	4.300	4.700	0.169	0.185
e	1.270 TYP		0.050 TYP	
e1	2.440	2.640	0.096	0.104
L	14.100	14.500	0.555	0.571
Φ		1.600		0.063
h	0.000	0.380	0.000	0.015

## TO-92 Suggested Pad Layout

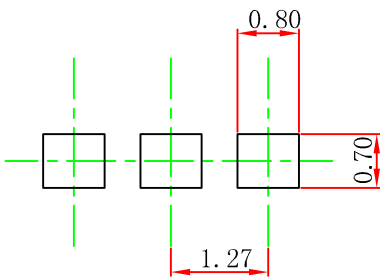

### Note:

1. Controlling dimension: in millimeters.
2. General tolerance:  $\pm 0.05\text{mm}$ .
3. The pad layout is for reference purposes only.

### NOTICE

JCET reserve the right to make modifications, enhancements, improvements, corrections or other changes without further notice to any product herein. JCET does not assume any liability arising out of the application or use of any product described herein.

TO-92 PACKAGE TAPEING DIMENSION

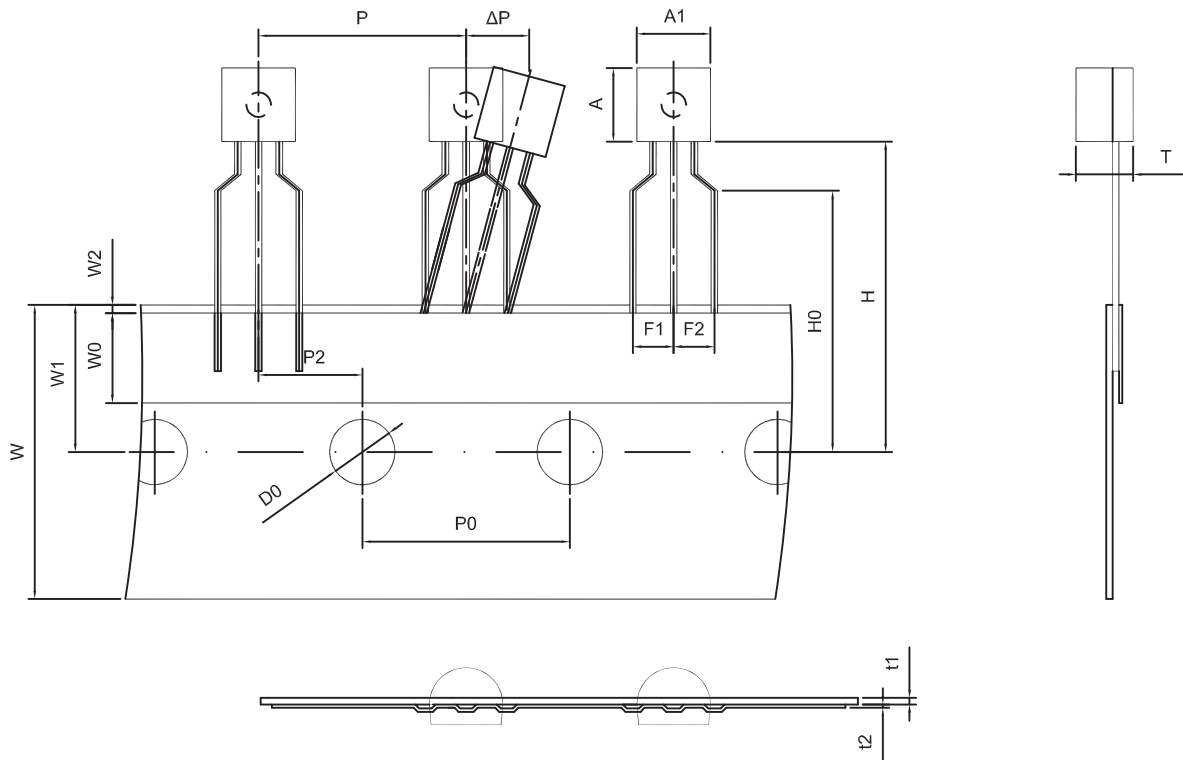

Dimiensions are in millimeter								
A1	A	T	P	P0	P2	F1	F2	W
4.5	4.5	3.5	12.7	12.7	6.35	2.5	2.5	18.0
W0	W1	W2	H	H0	D0	t1	t2	ΔP
6.0	9.0	1.0 MAX.	19.0	16.0	4.0	0.4	0.2	0

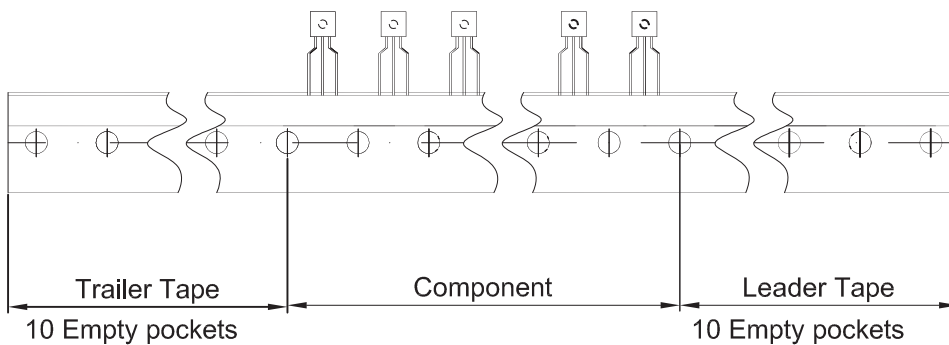

Package	Box	Box Size(mm)	Carton	Carton Size(mm)
TO-92	2000 pcs	333×162×43	20,000 pcs	350×340×250

## X-ON Electronics

Largest Supplier of Electrical and Electronic Components

*Click to view similar products for [Voltage References](#) category:*

*Click to view products by [Changjiang](#) manufacturer:*

Other Similar products are found below :

[AS431ARTR-E1](#) [AZ431BR-ATRE1](#) [5962-8686103XC](#) [NCV431BVDMR2G](#) [REF01J/883](#) [SC431ILPRAG](#) [AP432AQG-7](#) [LM4040B25QFTA](#)  
[REF5020IDGKR](#) [TL431ACZ](#) [KA431SLMF2TF](#) [KA431SMF2TF](#) [KA431SMFTF](#) [LM4040QCEM3-3.0/NOPB](#) [LM4041C12ILPR](#)  
[LM4120AIM5-2.5/NOP](#) [LM431SCCMFX](#) [ZXRE250BSA-7](#) [ZXRE125DN8TA](#) [TS3330AQPR](#) [ZXRE250ASA-7](#) [ZTL431ASE5TA](#)  
[ADR3512WCRMZ-R7](#) [REF3012AIDBZR](#) [LM385BM-2.5/NOPB](#) [LM385D-2.5R2G](#) [LM4040AIM3-10.0](#) [LM4040BIM3-4.1](#) [LM4040CIM3-](#)  
[10.0](#) [LM4040CIM3X-2.0/NOPB](#) [LM4041QDIM3-ADJ/NO](#) [LM4051BIM3-ADJ/NOPB](#) [LM4051CIM3X-1.2/NOPB](#) [LM4128CMF-1.8/NOPB](#)  
[LM4132DMF-1.8/NOPB](#) [LM4132EMF-1.8/NOPB](#) [LM4132EMF-2.0/NOPB](#) [LM431CIM](#) [LM385BD-2.5R2G](#) [LM385M-2.5/NOPB](#)  
[LM4030AMF-4.096/NOPB](#) [LM4040D30ILPR](#) [LM4051CIM3X-ADJ/NOPB](#) [AP432YG-13](#) [AP431IANTR-G1](#) [AP431AWG-7](#) [AS431ANTR-](#)  
[G1](#) [AS431AZTR-G1](#) [AS431BZTR-E1](#) [AN431BN-ATRG1](#)