



1A LOW DROPOUT LINEAR REGULATOR

CJA1117B-XXX

GENERAL DESCRIPTION

The CJA1117B-XXX is a series of low dropout three-terminal regulators with a dropout of 1.15V(typ.) at 1A output current.

The CJA1117B-XXX series provides current limiting and thermal shutdown. Its circuit includes a trimmed bandgap. reference to assure output voltage accuracy to be within 1.5%. Current limit is trimmed to ensure specified. output current and controlled short-circuit current. On-chip thermal shutdown provides protection against any combination of overload and ambient temperature that would create excessive junction temperature.

The CJA1117B-XXX has an adjustable version, that can provide the output voltage from 1.25V to 5V with only 2 external resistors.

FEATURES

- Low Dropout Voltage: 1.15V(typ.) at 1A Output Current
- Trimmed Current Limit
- On-Chip Thermal Shutdown
- Three-Terminal Adjustable or Fixed 1.8V, 2.5V, 3.3V, 5V
- Operation Junction Temperature: 0 °C to 125°C

APPLICATIONS

- PC Motherboard
- LCD Monitor
- Graphic Card
- DVD-Video Player
- NIC/Switch
- Telecom Modem
- ADSL Modem
- Printer and Other Peripheral Equipment

PACKAGE AND PIN CONFIGURATIONS

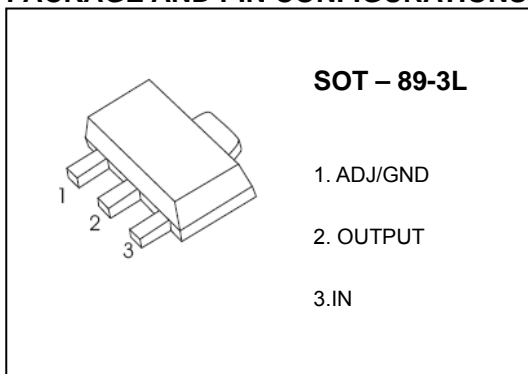

ORDERING INFORMATION

Package	Operating Junction Temperature Range	Part NO.
SOT-89-3L	0 to 125°C	CJA1117B-ADJ
		CJA1117B-1.8
		CJA1117B-2.5
		CJA1117B-3.3
		CJA1117B-5.0

ABOSLUTE MAXIMUM RATINGS ($T_a=25^\circ\text{C}$ unless otherwise noted)

Parameter	Symbol	Value	Unit
Input Voltage	V_i	20	V
Maximum Junction Temperature	T_j	150	°C
Storage Temperature	T_{stg}	-55~+150	°C
Thermal Resistance from Junction to Ambient	$R_{\theta\text{JA}}$	250	°C/W
Lead Temperature (Soldering, 10sec.)	T_L	260	°C
ESD Voltage (Machine Model)	V_{ESD}	400	V

Note: Stresses greater than those listed under "Absolute Maximum Ratings" may cause permanent damage to the device. These are stress ratings only, and functional of the device at these or any other conditions beyond those indicated under "Recommended Operating Conditions" is not implied. Exposure to "Absolute Maximum Ratings" for extended periods may affect device reliability.

RECOMMENDED OPERATING CONDITIONS

Parameter	Symbol	Value	Unit
Input Voltage	V_i	15	V
Operating Junction Temperature	T_j	0~+125	°C

ELECTRICAL CHARACTERISTICS ($V_{IN} \leq 10V$, $T_J = 25^\circ C$ unless otherwise specified.)

Parameter	Symbol	Part NO.	Test conditions	Min	Typ	Max	Unit
Reference Voltage	V_{IROC}	CJA1117B-ADJ	$I_{OUT} = 10mA$, $V_{IN} - V_{OUT} = 3.23$	1.231	1.250	1.269	V
			$10mA \leq I_{OUT} \leq 1A$, $2.75V \leq V_{IN} - V_{OUT} \leq 13.25V$	1.225	1.250	1.275	
Output Voltage	V_O	CJA1117B-1.8	$I_{OUT} = 10mA$, $V_{IN} = 3.8V$	1.773	1.8	1.827	V
			$10mA \leq I_{OUT} \leq 1A$, $3.3V \leq V_{IN} \leq 12V$	1.764	1.8	1.836	
		CJA1117B-2.5	$I_{OUT} = 10mA$, $V_{IN} = 4.5V$	2.463	2.5	2.538	V
			$10mA \leq I_{OUT} \leq 1A$, $4V \leq V_{IN} \leq 12V$	2.450	2.5	2.550	
		CJA1117B-3.3	$I_{OUT} = 10mA$, $V_{IN} = 5.3V$	3.251	3.3	3.350	V
			$10mA \leq I_{OUT} \leq 1A$, $4.8V \leq V_{IN} \leq 12V$	3.234	3.3	3.366	
		CJA1117B-5.0	$I_{OUT} = 10mA$, $V_{IN} = 7.0V$	4.925	5.0	5.075	V
			$10mA \leq I_{OUT} \leq 1A$, $6.5V \leq V_{IN} \leq 12V$	4.9	5.0	5.1	
Line Regulation	LNR	CJA1117B-ADJ	$I_{OUT} = 10mA$, $1.5V \leq V_{IN} - V_{OUT} \leq 12V$		0.035	0.2	mV
		CJA1117B-1.8	$I_{OUT} = 10mA$, $1.5V \leq V_{IN} - V_{OUT} \leq 10.2V$		1	7	
		CJA1117B-2.5	$I_{OUT} = 10mA$, $1.5V \leq V_{IN} - V_{OUT} \leq 9.5V$		1	7	
		CJA1117B-3.3	$I_{OUT} = 10mA$, $1.5V \leq V_{IN} - V_{OUT} \leq 8.7V$		1	7	
		CJA1117B-5.0	$I_{OUT} = 10mA$, $1.5V \leq V_{IN} - V_{OUT} \leq 7V$		1	10	
Load Regulation	LDR	CJA1117B-ADJ	$V_{IN} - V_{OUT} = 1.5V$, $10mA \leq I_{OUT} \leq 1A$		0.2	0.4	mV
		CJA1117B-1.8				7.2	
		CJA1117B-2.5				10	
		CJA1117B-3.3				13.2	
		CJA1117B-5.0				20	
Dropout Voltage	V_D		$\Delta V_{REF} = 1\%$, $I_{OUT} = 1.0A$			1.3	V
Current Limit	I_{limit}		$V_{IN} - V_{OUT} = 2V$	1			A
Adjust Pin Current					60	120	μA
Minimum Load Current	I_L		$1.5V \leq V_{IN} - V_{OUT} \leq 12V$ (ADJ only)		1.7	5	μA
Quiescent Current	I_q		$V_{IN} = V_{OUT} + 1.25V$ (ADJ except)		5	10	mA
Ripple Rejection	RR		$f = 120Hz$, $C_{OUT} = 22\mu F$ Tantalum, $V_{IN} - V_{OUT} = 3V$, $I_{OUT} = 1A$	60	75		dB
Temperature Stability					0.5		%
Long-Term Stability			$T_A = 125^\circ C$, 1000hrs		0.3		%
RMS Output Noise (% of VOUT)			$T_A = 25^\circ C$, $10Hz \leq f \leq 10kHz$		0.003		%
Thermal Shutdown Hysteresis					25		$^\circ C$

* With package soldering to copper area over backside ground plane or internal power plane $R_{\theta JA}$ can vary from $46^\circ C/W$ to $>90^\circ C/W$ depending on mounting technique and the size of the copper area

FUNCTIONAL BLOCK DIAGRAM

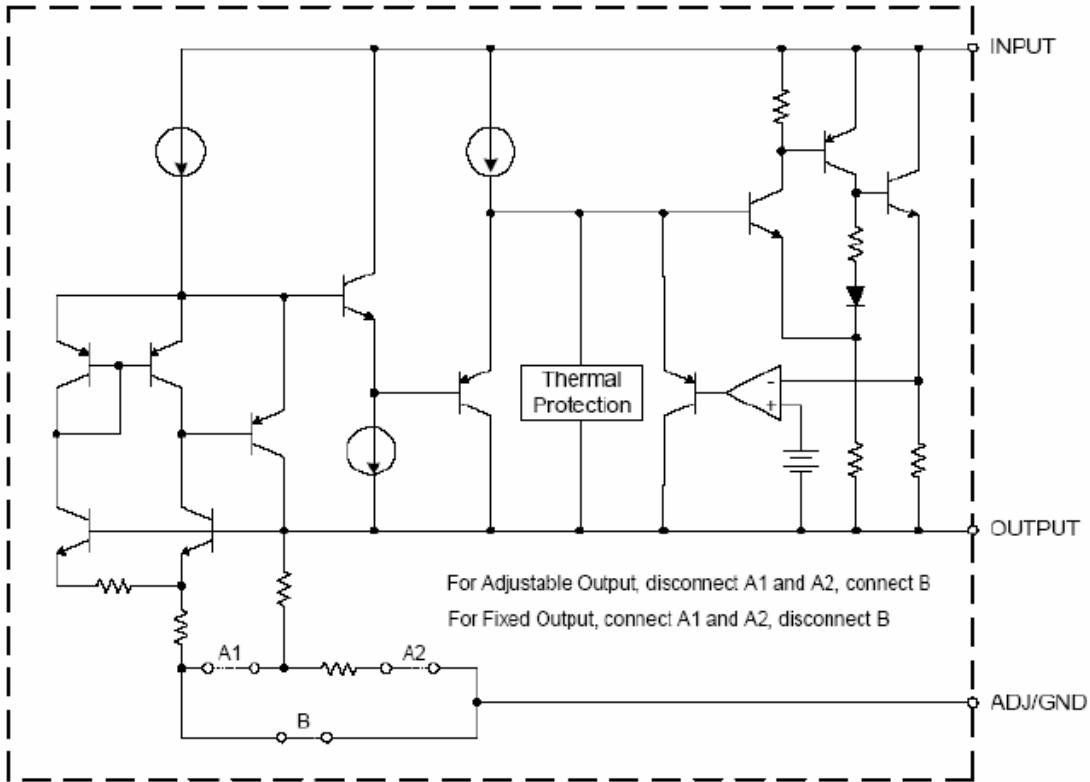

TYPICAL APPLICATION CIRCUIT

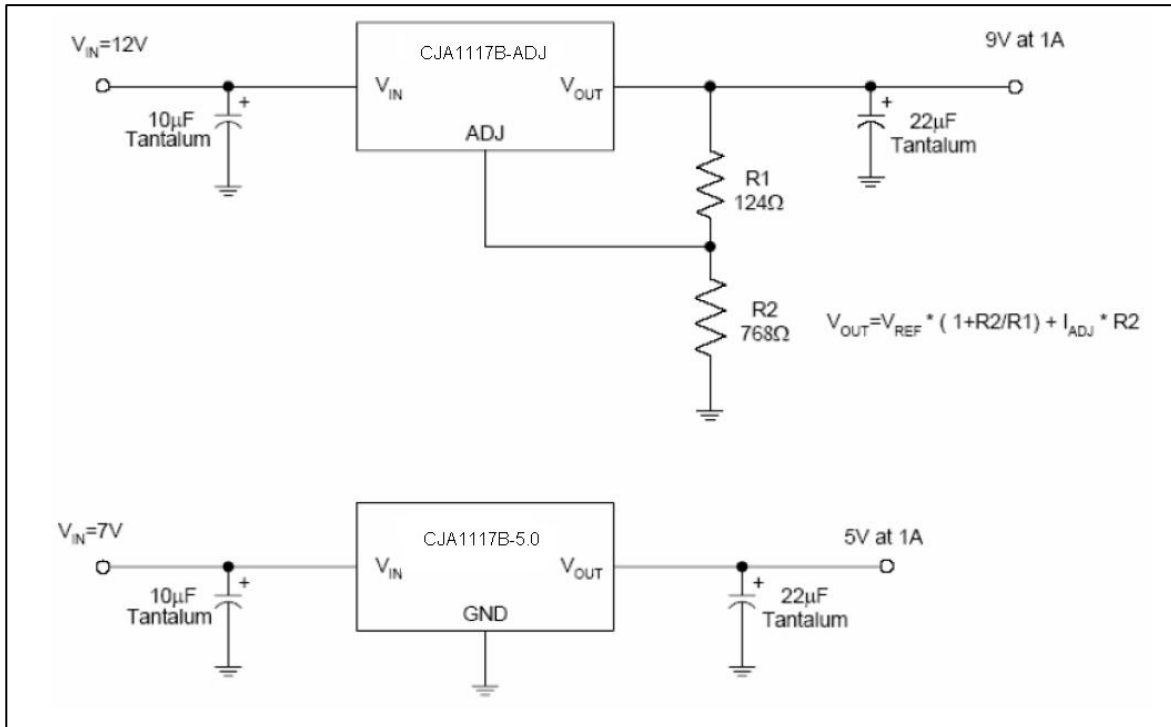

X-ON Electronics

Largest Supplier of Electrical and Electronic Components

Click to view similar products for [Linear Voltage Regulators](#) category:

Click to view products by [Changjiang](#) manufacturer:

Other Similar products are found below :

[LV56831P-E](#) [LV5684PVD-XH](#) [MCDTSA6-2R](#) [L7815ACV-DG](#) [PQ3DZ53U](#) [LV56801P-E](#) [TLE42794G](#) [L78L05CZ/1SX](#) [L78LR05DL-MA-E](#) [636416C](#) [714954EB](#) [BA033LBSG2-TR](#) [LV5680P-E](#) [L78M15CV-DG](#) [TLS202B1MBV33HTSA1](#) [L79M05T-E](#) [TLS202A1MBVHTSA1](#) [L78LR05D-MA-E](#) [NCV317MBTG](#) [NTE7227](#) [LV5680NPVC-XH](#) [LT1054CN8](#) [MP2018GZD-5-Z](#) [MP2018GZD-33-Z](#) [MIC5281-3.3YMM](#) [RT9078-28GQZ](#) [MC78L06BP-AP](#) [TA48LS05F\(TE85L,F\)](#) [TC47BR5003ECT](#) [TCR2LN12,LF\(S](#) [TCR2LN28,LF\(S](#) [TCR2LN30,LF\(S](#) [TCR3DF295,LM\(CT](#) [TCR3DF40,LM\(CT](#) [BA178M20CP-E2](#) [L78M12ABDT](#) [LR645N3-G-P003](#) [LR645N3-G-P013](#) [ZXTR2005P5-13](#) [SCD7812BTG](#) [TCR3DF335,LM\(CT](#) [TLE42994E V33](#) [ZXTR2008K-13](#) [ZXTR2005K-13](#) [L88R05DL-E](#) [ADP3300ARTZ-2.7RL7](#) [LM120K-15/883](#) [IFX54441LDVXUMA1](#) [LM317D2T-TR](#) [LM350T/NOPB](#)