

1. Features

- 1) High common mode impedance at high frequency effects excellent noise suppression performance.
- 2) FDCW3216series realizes small size and low profile 3.2*1.6*1.8 mm.
- 3) 100% Lead (Pb) & Halogen-Free and RoHS compliant.



2. Applications

- Power switch and servers.
- Telecommunication applications.
- Countering common mode noise affecting signals in high-speed lines.
- USB communication.
- Panel link for LCD panels.

3. Product Identification

FDCW 3216 -2 -600 T F

① ② ③ ④ ⑤ ⑥

- ① FDCW ----- Series name
- ② 3216 ----- Dimension
- ③ 2 ----- 2 lines
- ④ 600 ----- Common Mode Impedance (Ω)
- ⑤ T ----- Packing(Tape & Reel)
- ⑥ F ----- HSF Products(Hazardous Substance Free Products)

4. Dimensions (unit:mm)

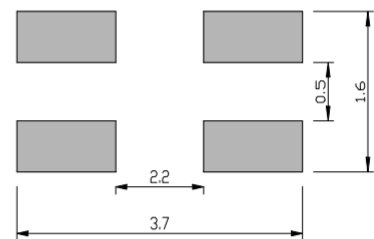
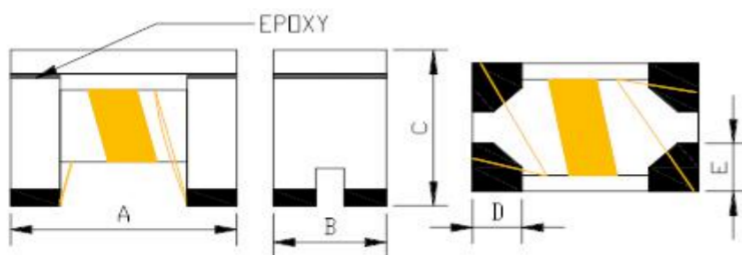

Recommend Land Pattern

A	B	C	D	E
3.20±0.20	1.60±0.20	1.80±0.20	0.6TYP	0.6TYP

5. Structure and Components

No	Part Name	Material Name
①	Lid	Ni-Zn Ferrite
②	Epoxy	Epoxy resin
③	Wire	Enameled copper wire
④	Core	Ni-Zn Ferrite
⑤	Electrode structure	Ag+Ni+Sn plating

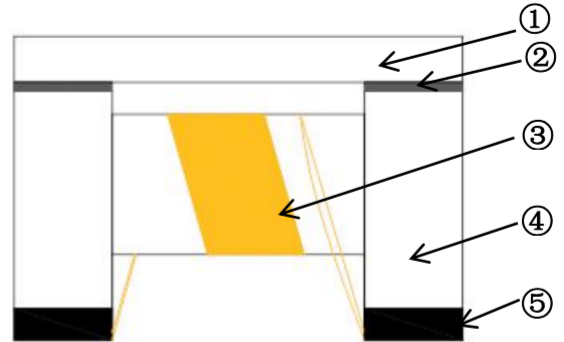

6. Chematic Diagram

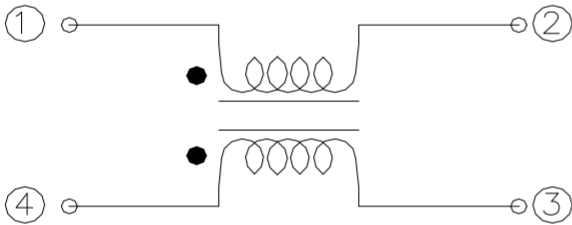

7. MEASURING CIRCUITS 2LINE

1) Common mode:

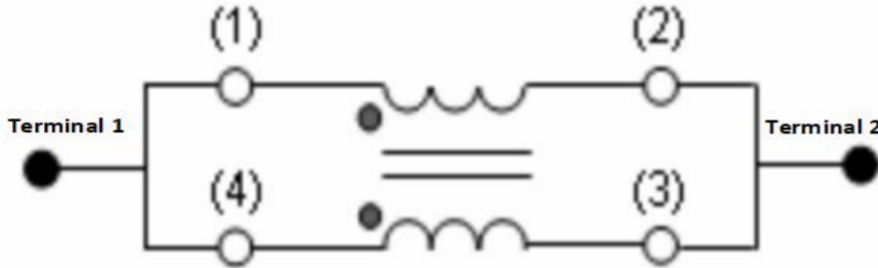

2) Differential mode:

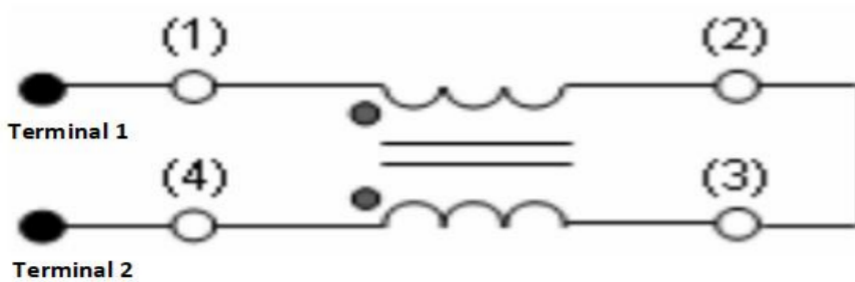

8. Electrical Characteristics

品名	Z (共模阻抗) @100MHZ	DCR	IR	Rated Voltage (Vdc)	Rated Current
	Ω	mΩ	MΩ	V	mA
	±25%	MAX	MIN	/	MAX
FDCW3216-2-500TF	50	250	10	50	400
FDCW3216-2-900TF	90	300	10	50	370
FDCW3216-2-161TF	160	400	10	50	340
FDCW3216-2-261TF	260	500	10	50	310
FDCW3216-2-601TF	600	800	10	50	260
FDCW3216-2-102TF	1000	1000	10	50	230
FDCW3216-2-222TF	2200	1200	10	50	200

Notes

1. All test data is referenced to 25 °C ambient
2. Operating temperature range - 40 °C to + 125 °C
3. Irms (A):DC current (A) that will cause an approximate ΔT of 40 °C(reference ambient temperature is 25 °C)
4. The part temperature (ambient + temp rise) should not exceed 125 °C under worst case operating conditions.
Circuit design, component placement, PWB trace size and thickness, airflow and other cooling provisions all affect the part temperature. Part temperature should be verified in the end application.

9. Typical impedance vs. frequency

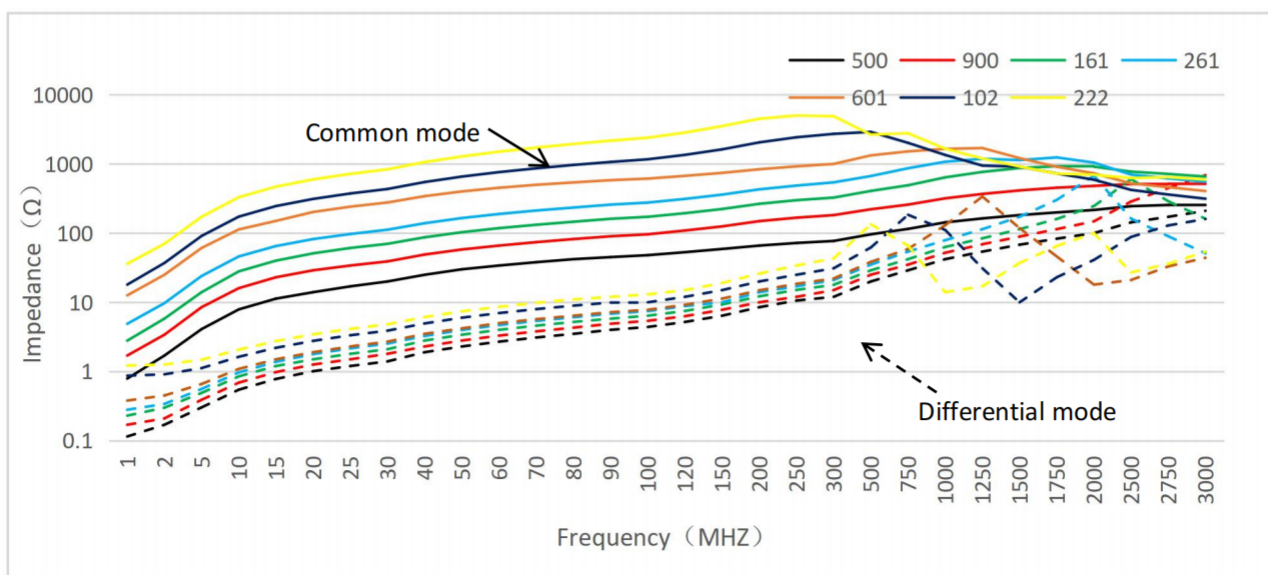

10. Reliability Test

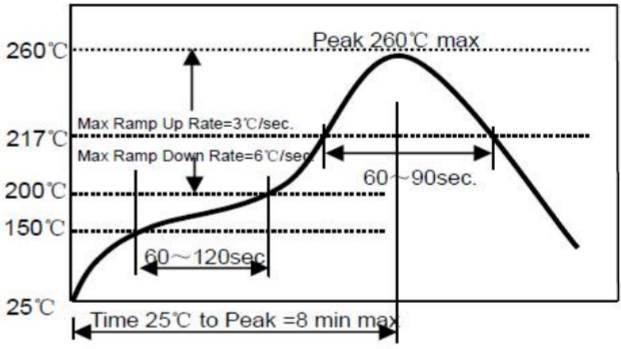
Items	Requirements	Test Methods and Remarks
Resistance to Soldering Heat	<ol style="list-style-type: none"> No visible mechanical damage Impedance change: Within $\pm 20\%$ 	<ol style="list-style-type: none"> Solder on PCB to Reflow test Peak Temp. $260 \pm 5^\circ\text{C}$ 5~10 secs ,Cycles :2 times..Re-flowing Profile: Please refer to Fig-1 Test board thickness: 1.5mm Test board material: glass epoxy resin The specimen shall be stored at standard atmospheric conditions for 1 hour, after which the measurement shall be made.product showed no damage under microscope. <p style="text-align: center;">Fig-1</p> 
High Temperature	<ol style="list-style-type: none"> No visible mechanical damage Impedance change: Within $\pm 20\%$ 	<ol style="list-style-type: none"> Temperature: $125 \pm 2^\circ\text{C}$ Duration: 1000 hours <p>The specimen shall be stored at standard atmospheric conditions for 1 hour, after which the measurement shall be made.</p>
Steady damp-heat	<ol style="list-style-type: none"> No visible mechanical damage Impedance change: Within $\pm 20\%$ 	<ol style="list-style-type: none"> Temperature: 85°C Humidity: 85% RH Duration: 1000 hours The specimen shall be stored at standard atmospheric conditions for 1 hour, after which the measurement shall be made.
Mechanical Vibration	<ol style="list-style-type: none"> No visible mechanical damage Impedance change: Within $\pm 20\%$ 	<ol style="list-style-type: none"> Frequency: 10HZ~55HZ~10HZ/Min Cycles Amplitude: 1.5 mm Directions: X,Y,Z Time: 2 hours in each directions (total of 6 hours)

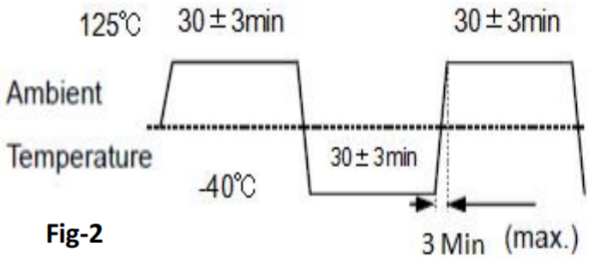
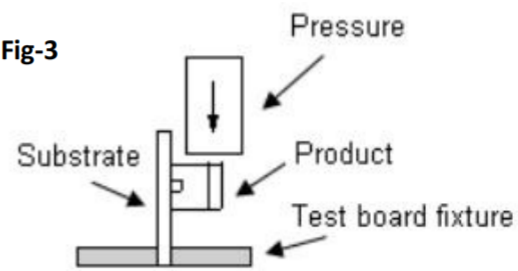
Items	Requirements	Test Methods and Remarks
Thermal Shock	1.No visible mechanical damage 2.Impedance change: Within $\pm 20\%$	1.Temperature and time: -40°C for 30 ± 3 min $\rightarrow 125^{\circ}\text{C}$ for 30 ± 3 min, please refer to Fig-2 2.Transforming interval: Max. 3 Min 3.Tested cycle: 1000 cycles 4.The specimen shall be stored at standard atmospheric conditions for 1 hour, after which the measurement shall be made.  <p>Fig-2</p>
Salt Spray	1.No visible mechanical damage 2.Impedance change: Within $\pm 20\%$	1. Salt concentration: $(5 \pm 1)\%$ (mass percent) 2. pH value:6.5 - 7.2 3. temperature: $35 \pm 2^{\circ}\text{C}$ 4. humidity: 85% 5. time: 24 hours 6. in normal temperature and humidity for 1 ~ 2 hours, testing inductance, the inductance value change can not be more than before test $\pm 10\%$.
Terminal strength	No visible mechanical damage	1. The electrode of the inductor is soldered to the PCB, to Fig-3 Then apply a force in the direction of the arrow. 2. 8N force. 3. Keep time: $10(\pm 1)\text{s}$ The first three tests were OK, and the force was applied until the peak value of the product peeling. The test speed was set in the range of 3 ~ 8mm/min.  <p>Fig-3</p>

11. Packaging Information

1) Tape Packaging Dimensions (Unit: mm)

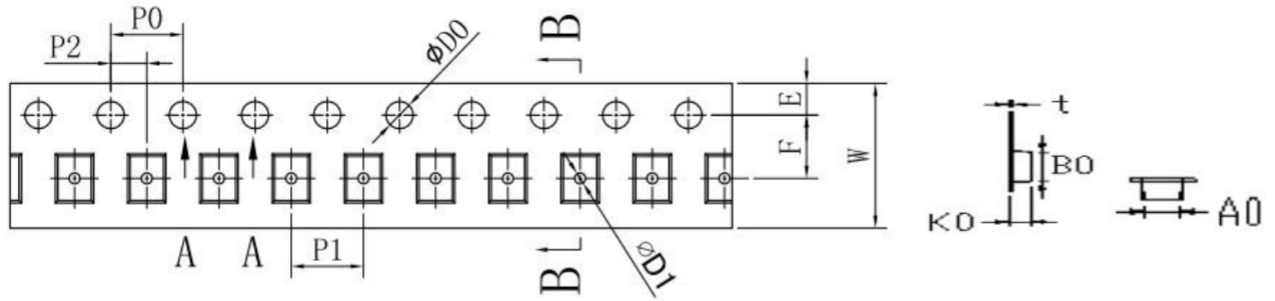

Type	W	P1	A0	B0	K0	t	E	F	P2	D0	D1	P0
FDCW 3216	8.00 ±0.10	4.00 ±0.10	1.90 ±0.10	3.60 ±0.10	1.95 ±0.10	0.25 ±0.05	1.75 ±0.10	3.50 ±0.10	2.00 ±0.10	1.55 ±0.05	1.00 ±0.10	4.00 ±0.10

2) Leader and blank portion

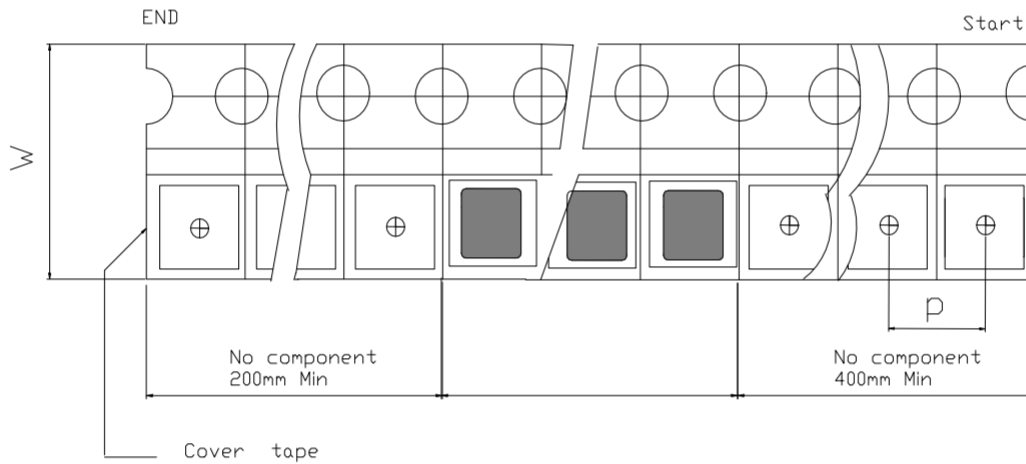

3) Taping Drawings

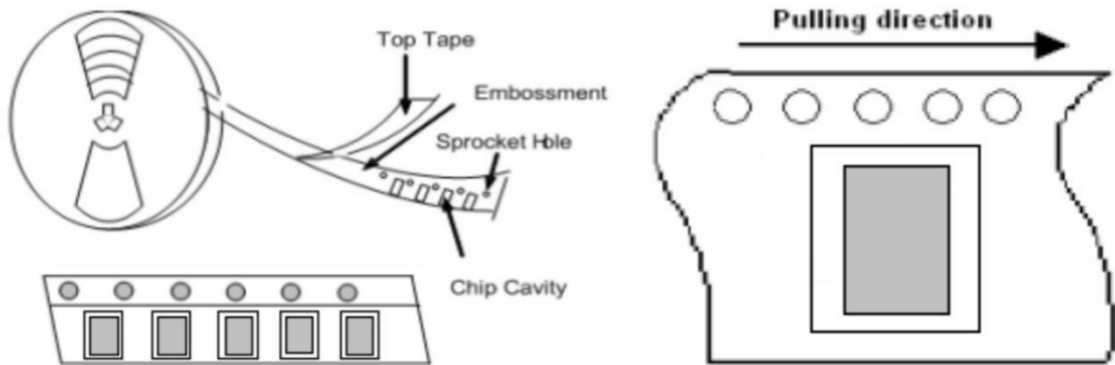

4) Reel Dimensions (Unit: mm)

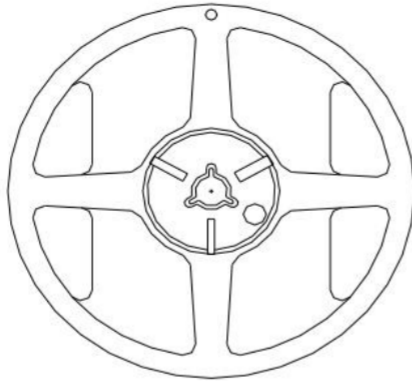
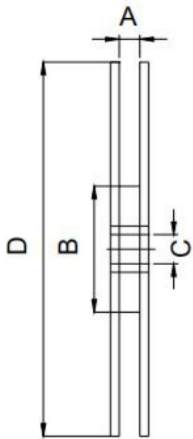

A (mm)	9.50 ± 1.0
B (mm)	60.0 ± 1.0
C (mm)	13.0 ± 0.2
D (mm)	178.0 ± 1.0

5) Packaging Quantity(PCS)

Type	Standard Quantity		
	Reel	Inner box	Carton box
FDCW3216	2000 pcs / reel	5Reel / box (10000 pcs)	10 Middle boxes, (100000 pcs)

6) Peel force of top cover tape

The peel speed shall be about 300mm/minute.

The peel force of top cover tape shall be between 10 to 100gf.

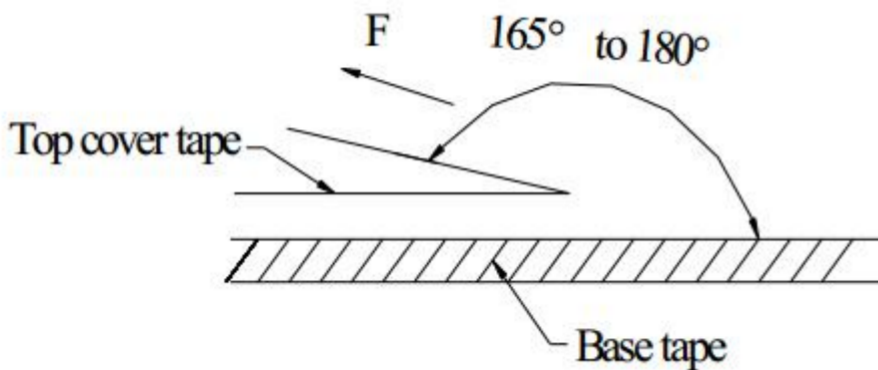

7) Reel Label

- Label on the reel
 - Customer's part Number
 - Lot Number
 - Quantity
 - date code

- Shipping Label
 - Customer's part Number
 - Manufacturer's part Number
 - Quantity
 - date code

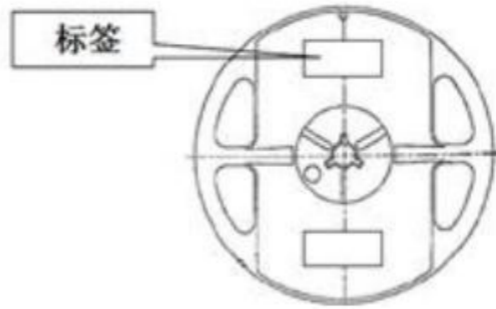

8) Inner Box

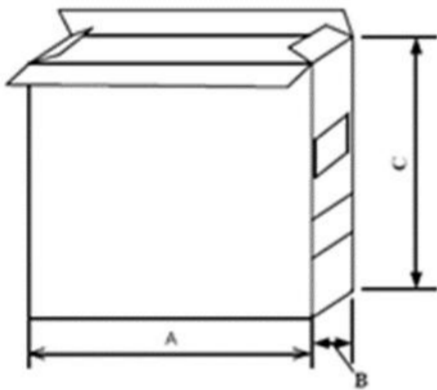

Packaging Type	A (mm)	B (mm)	C (mm)
Inner box	188	195	67

9) Carton

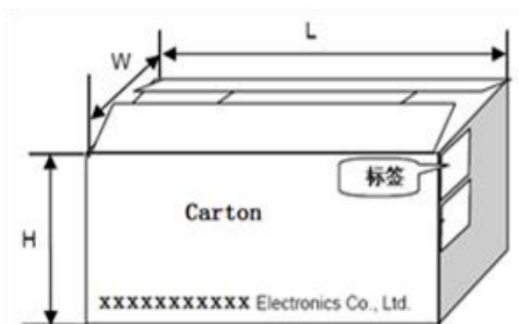

Packaging Type	L (mm)	W (mm)	H (mm)
Carton	390	350	215

X-ON Electronics

Largest Supplier of Electrical and Electronic Components

Click to view similar products for [Common Mode Chokes / Filters](#) *category:*

Click to view products by [Changjiang Microelectronics](#) *manufacturer:*

Other Similar products are found below :

[PE-64683](#) [RD5122-6-9M6](#) [RD6137-6-7M5](#) [RD8147-16-3M0](#) [ST6118T-R](#) [FE3X025-10-7NL](#) [RD7147-25-0M7](#) [TCM0806G-350-2P-T](#)
[TCM0806G-650-2P-T](#) [IND-0110](#) [UAL21VR0802000](#) [UALSC023000000](#) [UALSC1020JH000](#) [UALSU10VD20010](#) [UALSU9VD070100](#) [36-00037](#) [UALW21HS072450](#) [UALSU9H0208000](#) [UAL24VK06450CH](#) [PLT10HH501100PNB](#) [PLT10HH401100PNB](#) [PLT10HH1026R0PNB](#)
[36-00029-01](#) [PE-67531](#) [TLH10UB](#) [113 0R5](#) [2752045447](#) [7351V](#) [CMF16-153131](#) [RD7147-6-6M0](#) [T8116NLT](#) [FE2X10-4-2NL](#) [36-00029-07](#)
[T8003NLT](#) [CTX01-13663](#) [CTX66-19521-R](#) [RC212-0.5-10M](#) [RC112-0.4-15M](#) [RC212-0.6-6M8](#) [RC212-0.4-15M](#) [RC112-0.3-30M](#)
[WTCF2012Z0M751PB](#) [PH9408.814NLT](#) [PAC6006.364NLT](#) [PAC6006.444NLT](#) [PAC6006.204NLT](#) [PH9407.204NLT](#) [PAC6006.264NLT](#)
[PH9408.105NLT](#) [PH9408.494NLT](#) [PAC6006.104NLT](#)