

Specification for Approval

Customer	
Product Name	Wire Wound Molded SMD Power Inductors
Customer Cjiang P/N:	
Cjiang P/N:	FEXL series

New Released, Revised] SPEC No.:

REMARK:		
Customer Approval Feedback		

● 深圳市长江微电科技有限公司

SZ CJIANG TECHNOLOGY CO.,LTD

ADD: 11F, International Science and Technology Building, Fuhong Road, Futian District, Shenzhen

Factory ADD: No. shanyang RD CJIANG Industrial Park HUAI'AN Section HUAI'AN City Jiangsu Province

TEL: 0755-82529562 FAX:0755-83977004

<http://www.CJING.COM.CN>

E-mail: BOND@Cjiang.com.cn; ann@cjiang.com.cn

Version change history

Rev	Date	Description	APPROVED	CHECKED	DRAWN
1.0	2023/11/17	Document formulation	徐舒霞	马月	朱小娟
2.0	2024/3/25	Merge all sizes	BOND	XUETING	XUETING

Caution :

All products listed in this specification are developed, designed and intended for use in general electronics equipment. The products are not designed or Warranted to meet the requirements of the applications listed below, whose performance and/or quality require especially high reliability, or whose failure, malfunction or trouble might directly cause damage to society, person, or property. Please understand that we are not responsible for any damage or liability caused by use of the products in any of the applications below. Please contact us for more details if you intend to use our products in the following applications.

1. Aircraft equipment.
2. Aerospace equipment.
3. Undersea equipment.
4. nuclear control equipment.
5. military equipment.
6. Power plant equipment.
7. Medical equipment.
8. Transportation equipment (automobiles, trains, ships,etc.)
9. Traffic signal equipment.
10. Disaster prevention / crime prevention equipment.
11. Data-processing equipment.
12. Applications of similar complexity or with reliability requirements comparable to the applications listed in the above.



Introduction

- Soft saturation.
- High current , low DCR , high efficiency.
- Very low acoustic noise and very low leakage flux noise.
- High reliability.
- 100% Lead(Pb)-Free and RoHS compliant.
- Operating temperature -55~+125 °C (Including self -temperature rise)



Applications

- Note PC power system , incl. IMVP-6
- DC/DC converter

Dimensions (Unit: mm)



Code	Dimensions(mm)
A	8.9±0.3
B	8.5±0.3
C	7.7±0.3
D	See Spec table
E	1.8±0.3
F	3.5±0.5

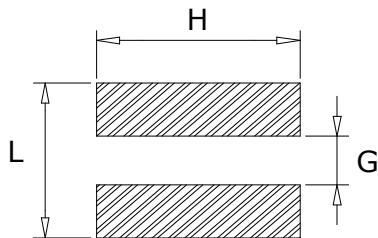

L	10.5ref
H	11.0ref
G	3.7ref

Recommend Land Pattern

Unit : mm

series	A	B	C	D	E	F	L	H	G
FEXL0420A	4.1±0.2	4.1±0.2	1.9±0.2	3.4±0.3	0.88±0.3	1.7±0.3	3.4ref	3.8ref	1.4ref
FEXL0430A	4.1±0.25	4.1±0.25	2.8±0.2	3.4±0.3	0.88±0.3	1.7±0.3	3.4ref	3.8ref	1.4ref
FEXL0520A	5.5±0.2	5.3±0.2	1.9±0.2	4.3±0.3	1.1±0.3	2.3±0.3	4.5ref	4.7ref	2.0ref
FEXL0530A	5.5±0.2	5.3±0.2	2.9±0.2	4.3±0.3	1.1±0.3	2.3±0.3	4.5ref	4.7ref	2.0ref
FEXL0550A	5.5±0.2	5.3±0.2	4.8±0.2	4.3±0.3	1.1±0.3	2.3±0.3	4.5ref	4.7ref	2.0ref
FEXL0630A	6.6±0.2	6.4±0.2	2.9±0.2	See Spec table	1.4±0.3	2.6±0.3	5.6ref	5.6ref	2.5ref
FEXL0650A	6.6±0.2	6.4±0.2	4.8±0.2	See Spec table	1.4±0.3	2.6±0.3	5.6ref	5.6ref	2.5ref
FEXL0660A	6.6±0.2	6.4±0.2	5.8±0.2	5.3±0.3	1.4±0.3	2.6±0.3	5.6ref	5.6ref	2.5ref
FEXL0720A	7.8±0.25	7.6±0.2	1.85±0.2	See Spec table	1.75±0.3	3.15±0.3	7.4ref	7.2ref	2.8ref
FEXL0730A	7.8±0.25	7.6±0.2	2.9±0.2	See Spec table	1.75±0.3	3.15±0.3	7.4ref	7.2ref	2.8ref
FEXL0770A	7.8±0.25	7.6±0.25	6.7±0.3	See Spec table	1.75±0.3	3.15±0.3	7.8ref	6.7ref	2.8ref
FEXL0880A	8.9±0.3	8.5±0.3	7.7±0.3	See Spec table	1.8±0.3	3.5±0.5	8.0ref	7.8ref	2.7ref
FEXL1010A	11.9±0.3	11.0±0.3	9.7±0.3	See Spec table	2.4±0.3	4.4±0.5	10.5ref	11.0ref	3.7ref
FEXL1031A	11.9±0.3	11.0±0.3	2.9±0.2	9.0±0.5	2.4±0.3	4.4±0.5	10.5ref	11.0ref	3.7ref
FEXL1060A	11.9±0.3	11.0±0.3	5.7±0.3	See Spec table	2.4±0.3	4.5±0.5	10.5ref	11.0ref	3.7ref
FEXL1580A	16.5±0.3	15.5±0.3	7.7±0.3	13.2±0.5	3.2±0.3	7.0±0.5	15.0ref	15.0ref	6.0ref
FEXL1510A	16.5±0.3	15.5±0.3	9.7±0.3	13.2±0.5	3.2±0.3	7.0±0.3	15.0ref	15.0ref	6.0ref
FEXL1513A	16.5±0.3	15.5±0.3	12.7±0.3	13.2±0.5	3.2±0.3	7.0±0.5	15.0ref	15.0ref	6.0ref

Marking

Note : Using Ink for marking



Marking:

Example	Nominal Value
0.18 μ H	R18
1.2 μ H	1R2
4.5 μ H	4R5

Structure and Componen

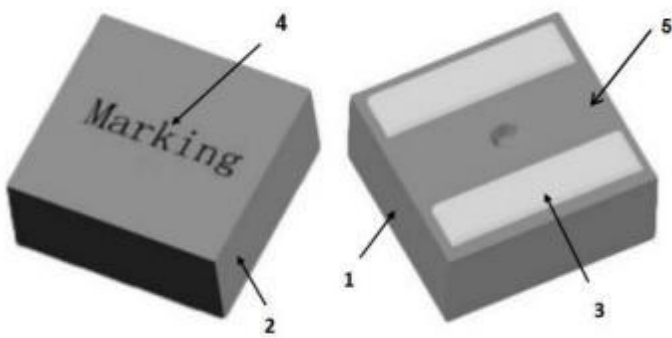

NO	Components	Material
1	CORE	Alloy Powder
2	WIRE	Polyester Wire or equivalent.
3	Clip	100% Pb free solder
4	Ink	Halogen-free ketone
5	paint	Epoxy resin

Appendix A: Electrical Characteristics

FEXL0420A series

Part No.	L0 (μH)±20 %	DCR (mΩ) MAX	Isat (A)		Irms (A)Typ	
			Max	Typ	20℃ rise	40℃ rise
FEXL0420A-R10M	0.1	2.42	33	38	13.5	18
FEXL0420A-R22M	0.22	4.6	18.8	19.5	13.0	16.8
FEXL0420A-R36M	0.36	6.3	15	17	11	14.5
FEXL0420A-R40M	0.4	7.73	13.5	15.5	10	14
FEXL0420A-R47M	0.47	8.58	13	14.5	9	12.5
FEXL0420A-R56M	0.56	9.3	12.6	14	8.5	12
FEXL0420A-R60M	0.6	9.52	12.3	13.7	8.0	11.7
FEXL0420A-R68M	0.68	11.2	10.9	12.3	7.8	10.7
FEXL0420A-R72M	0.72	11.6	10.6	12	7.6	10.5
FEXL0420A-1R0M	1.0	14.6	8.8	9.6	6.8	9.6
FEXL0420A-1R2M	1.2	17.9	7.8	9	6.6	9.0
FEXL0420A-1R5M	1.5	23.5	7.4	8	5.8	7.6
FEXL0420A-1R8M	1.8	28	7	7.5	5.2	7
FEXL0420A-2R2M	2.2	38.7	6	6.5	4.6	5.6

FEXL0430A series

Part No.	L0 (μH)±20 %	DCR (mΩ) MAX	Isat (A)		Irms (A)Typ	
			Max	Typ	20℃ rise	40℃ rise
FEXL0430A-R47M	0.47	7.26	15	17	10	14
FEXL0430A-R90M	0.90	10.1	9.0	10.0	8.2	11.2
FEXL0430A-1R0M	1.00	10.1	9.2	9.8	8.0	11.0
FEXL0430A-1R2M	1.20	11.5	8.7	9.2	7.8	9.8
FEXL0430A-1R5M	1.50	13.2	7.0	8.0	7.0	9.0
FEXL0430A-2R2M	2.20	22.6	6.1	7.0	6.0	7.8
FEXL0430A-3R3M	3.30	28.6	5.3	6.2	5.0	6.6
FEXL0430A-4R7M	4.7	44.1	4.0	4.5	3.9	5.1
FEXL0430A-6R8M	6.8	74.1	3.0	3.6	3.0	3.9

FEXL0520A series

Part No.	L0 (μH)±20 %	DCR (mΩ) MAX	Isat (A)		Irms (A)Typ	
			Max	Typ	20℃ rise	40℃ rise
FEXL0520A-R15M	0.15	4.60	27.0	30.0	13.9	18.8
FEXL0520A-R16M	0.16	4.60	27.0	30.0	13.9	18.8
FEXL0520A-R33M	0.33	7.00	24.0	26.0	10.5	14.4
FEXL0520A-R47M	0.47	8.05	20.0	22.0	10.1	14.1
FEXL0520A-R56M	0.56	9.54	16.0	19.0	9.9	13.9
FEXL0520A-R68M	0.68	10.2	14.0	16.0	9.6	13.4
FEXL0520A-R80M	0.8	11.8	13.5	15.5	9.4	13.0
FEXL0520A-R82M	0.82	12.7	13.0	15.0	8.5	12.0
FEXL0520A-1R0M	1.0	13.8	12.8	14.5	7.5	10.5
FEXL0520A-1R2M	1.2	16.3	12.2	14.0	6.8	9.40
FEXL0520A-1R5M	1.5	18.7	11.7	13.3	6.4	8.80

FEXL0530A series

Part No.	L0 (μH)±20 %	DCR (mΩ) MAX	Isat (A)		Irms (A)Typ	
			Max	Typ	20℃ rise	40℃ rise
FEXL0530A-R15M	0.15	2.31	32.5	36	14.3	22.2
FEXL0530A-R16M	0.16	2.33	32	35	14.2	22.2
FEXL0530A-R33M	0.33	3.52	26	28	13.8	19.2
FEXL0530A-R47M	0.47	4.13	24	26	13.7	18.4
FEXL0530A-R56M	0.56	4.52	20.2	22.2	13.6	17.7
FEXL0530A-R60M	0.6	4.52	20	22	13.6	17.7
FEXL0530A-R80M	0.8	5.65	18	20	10.1	13.1
FEXL0530A-R82M	0.82	5.78	17.6	19.7	9.9	12.9
FEXL0530A-1R0M	1.0	7.6	14.3	16.5	9	12.2
FEXL0530A-1R2M	1.2	9.7	13.5	15	8.5	11
FEXL0530A-1R5M	1.5	11.2	12.5	14	8	10.5
FEXL0530A-1R8M	1.8	12.7	11.3	12.3	7.6	10.1
FEXL0530A-2R2M	2.2	14.5	9	10	7.2	9.7
FEXL0530A-3R3M	3.3	23.1	8.7	9.5	5.9	8.1
FEXL0530A-4R7M	4.7	36.3	7	8.2	4.3	5.9

FEXL0550A series

Part No.	L0 (μH)±20 %	DCR (mΩ) MAX	Isat (A)		Irms (A)Typ	
			Max	Typ	20°C rise	40°C rise
FEXL0550A-4R7M	4.7	21	/	8.8	/	8.1
FEXL0550A-5R6M	5.6	24.2	7.2	8.6	5.3	7.2
FEXL0550A-6R8M	6.8	28.6	6.6	7.8	4.8	6.4
FEXL0550A-8R2M	8.2	32.5	6.1	7.2	4.6	6.1
FEXL0550A-100M	10	43	5.4	6.5	3.8	5
FEXL0550A-150M	15	76.7	3.2	3.7	3	3.9
FEXL0550A-220M	22	99.65	3	3.6	2.5	3.4

FEXL0630A series

Part No.	L0 (μH)±20 %	DCR (mΩ) MAX	Isat (A)		Irms (A)Typ		D(mm) ±0.3
			MAX	Typ	20°C rise	40°C rise	
FEXL0630A-R18M	0.18	1.75	36.0	40.0	24.0	32.0	5.30
FEXL0630A-R33M	0.33	2.50	28.0	32.0	20.0	25.0	5.55
FEXL0630A-R56M	0.56	3.31	25.0	29.0	17.0	22.0	5.30
FEXL0630A-R68M	0.68	5.17	21.0	25.0	15.0	20.0	5.30
FEXL0630A-1R0M	1.0	6.05	18.0	23.0	13.0	18.0	5.20
FEXL0630A-1R2M	1.2	7.40	16.0	22.0	12.0	16.0	5.15
FEXL0630A-1R5M	1.5	9.13	15.5	20.0	11.0	15.0	5.15
FEXL0630A-1R8M	1.8	10.2	13.0	18.2	10.0	14.0	5.10
FEXL0630A-2R2M	2.2	12.2	11.0	15.9	7.00	10.0	5.05
FEXL0630A-3R3M	3.3	20.8	9.00	12.2	6.00	8.00	5.00
FEXL0630A-4R5M	4.5	25.3	8.00	10.0	5.00	7.00	5.00

FEXL0650A series

Part No.	L0 (μH)±20 %	DCR (mΩ) MAX	Isat (A)		Irms (A)Typ		D(mm) ±0.3
			MAX	Typ	20°C rise	40°C rise	
FEXL0650A-R82M	0.82	4.18	20.0	24.0	16.0	21.0	5.3
FEXL0650A-1R0M	1.0	4.52	18.0	23.0	15.0	20.0	5.3
FEXL0650A-1R2M	1.2	5.83	16.0	22.0	14.0	18.0	5.3

FEXL0650A-1R5M	1.5	6.3	14.5	19.5	13.0	17.0	5.3
FEXL0650A-1R8M	1.8	7.1	13.5	18.5	12.0	16.0	5.3
FEXL0650A-2R2M	2.2	8.5	12.0	16.0	10.0	13.0	5.2
FEXL0650A-3R3M	3.3	12.5	10.0	12.5	8.5	11.0	5.2
FEXL0650A-4R3M	4.3	16.2	8.5	11.0	7.0	9.0	5.2
FEXL0650A-4R7M	4.7	18.4	8.0	10.5	6.5	8.5	5.2

FEXL0660A series

Part No.	L0 (μ H) \pm 20 %	DCR (m Ω) MAX	Isat (A)		I _{rms} (A)Typ	
			Max	Typ	20 $^{\circ}$ C rise	40 $^{\circ}$ C rise
FEXL0660A-1R0M	1.0	4.4	19.0	24.0	16.0	21.0
FEXL0660A-1R5M	1.5	6.1	15.0	20.0	13.5	17.5
FEXL0660A-2R2M	2.2	8.1	12.5	16.5	11.0	14.0
FEXL0660A-3R3M	3.3	12.3	11.0	13.0	9.0	12.0
FEXL0660A-4R7M	4.7	14.4	9.3	10.5	8.5	11.0
FEXL0660A-5R6M	5.6	15.9	8.7	9.9	7.6	10.0
FEXL0660A-6R8M	6.8	20.8	8.1	9.2	7.0	9.0
FEXL0660A-8R2M	8.2	26.4	8	8.4	6	8
FEXL0660A-100M	10	29.82	6.8	7.6	5	7
FEXL0660A-150M	15	43.75	5	5.8	4.5	6
FEXL0660A-220M	22	60.63	4.8	5.6	3.8	5
FEXL0660A-330M	33	105.0	2.5	3.7	2.3	3.6

FEXL0720A series

Part No.	L0 (μ H) \pm 20 %	DCR (m Ω) MAX	Isat (A)		I _{rms} (A)Typ		D(mm) \pm 0.3
			MAX	Typ	20 $^{\circ}$ C rise	40 $^{\circ}$ C rise	
FEXL0720A-R27M	0.27	3.5	32	35	16	21	6.6
FEXL0720A-R31M	0.31	4.8	31	34	14	20	6.2
FEXL0720A-R33M	0.33	4.8	31	34	13	19	6.2
FEXL0720A-R47M	0.47	6.2	25	28	12	17	6.2
FEXL0720A-R68M	0.68	9.2	23	25	10	13	6.2
FEXL0720A-1R0M	1.00	10.8	20	23	8.0	11	6.2

FEXL0730A series

Part No.	L0 (μH)±20 %	DCR (mΩ) MAX	Isat (A)		Irms (A)Typ		D(mm) ±0.3
			MAX	Typ	20℃ rise	40℃ rise	
FEXL0730A-1R0M	1.00	5.00	28.0	30.0	16.1	21.8	6.6
FEXL0730A-1R5M	1.50	8.25	23.5	25.0	12.0	15.3	6.6
FEXL0730A-2R2M	2.20	13.7	17.0	19.0	10.0	13.0	6.2
FEXL0730A-2R7M	2.70	15.4	13.5	16.0	9.20	11.4	6.2
FEXL0730A-3R3M	3.30	18.0	13.0	15.0	8.00	10.0	6.2
FEXL0730A-4R7M	4.70	26.7	12.2	13.5	6.90	9.00	6.2
FEXL0730A-5R6M	5.60	33.2	11.5	12.5	5.30	7.30	6.2
FEXL0730A-6R8M	6.80	42.5	11.0	12.0	4.50	6.80	6.2
FEXL0730A-8R2M	8.20	48.73	9.0	10.2	3.00	5.90	6.2

FEXL0770A series

Part No.	L0 (μH)±20 %	DCR (mΩ) MAX	Isat (A)		Irms (A)Typ		D(mm) ±0.3
			MAX	Typ	20℃ rise	40℃ rise	
FEXL0770A-3R3M	3.30	9.42	15.1	19.4	11.5	15.1	6.70
FEXL0770A-4R7M	4.70	13.5	14.0	15.5	10.5	13.6	6.70
FEXL0770A-6R8M	6.80	19.60	11.0	12.8	7.0	9.5	6.50

FEXL0880A series

Part No.	L0 (μH)±20 %	DCR (mΩ) MAX	Isat (A)		Irms (A)Typ		D(mm) ±0.3
			MAX	Typ	20℃ rise	40℃ rise	
FEXL0880A-1R8M	1.80	4.0	24.0	28.0	18.0	24.0	7.2
FEXL0880A-2R2M	2.20	4.3	22.0	25.0	16.0	21.5	7.2
FEXL0880A-3R3M	3.30	7.3	20.0	23.0	13.5	18.0	6.9
FEXL0880A-4R7M	4.70	9.8	17.0	19.0	10.5	14.6	6.9
FEXL0880A-6R8M	6.80	14.3	12.5	14.5	8.0	11.3	6.9
FEXL0880A-100M	10.0	22.9	10.0	11.0	6.6	8.7	6.9

FEXL1010A series

Part No.	L0 (μ H) \pm 20 %	DCR ($m\Omega$) MAX	Isat (A)		Irms (A)Typ		D(mm) \pm 0.3
			MAX	Typ	20 $^{\circ}$ C rise	40 $^{\circ}$ C rise	
FEXL1010A-2R2M	2.20	2.8	29	34	24.5	32	9.3
FEXL1010A-3R3M	3.30	4.1	23.4	27.4	18.2	25.0	9.3
FEXL1010A-4R7M	4.70	5.7	21.4	25.4	17.5	24.0	9.3
FEXL1010A-5R6M	5.60	7.2	19.6	23.6	15.7	21.2	9.3
FEXL1010A-6R8M	6.80	8.9	18.5	21.8	14.0	18.5	9.0
FEXL1010A-8R2M	8.20	12.4	16.3	18.3	12.9	17.1	9.0
FEXL1010A-100M	10.0	13.75	14.6	17.5	11.5	15.5	9.0
FEXL1010A-150M	15.0	19.30	12.5	15.5	9.9	13.8	9.0

FEXL1031A series

Part No.	L0 (μ H) \pm 20 %	DCR ($m\Omega$) MAX	Isat (A)		Irms (A)Typ	
			Max	Typ	20 $^{\circ}$ C rise	40 $^{\circ}$ C rise
FEXL1031A-R28M	0.28	1.60	58.0	65.0	25.5	35.0
FEXL1031A-R56M	0.56	2.75	39.0	44.0	23.0	32.0
FEXL1031A-R82M	0.82	4.10	32.0	38.0	18.0	25.0
FEXL1031A-R90M	0.90	4.20	31.0	36.0	17.0	24.0
FEXL1031A-1R0M	1.00	4.95	30.0	35.0	16.0	23.0
FEXL1031A-1R5M	1.50	6.60	25.0	30.0	12.0	18.0

FEXL1060A series

Part No.	L0 (μ H) \pm 20 %	DCR ($m\Omega$) MAX	Isat (A)		Irms (A)Typ		D(mm) \pm 0.3
			MAX	Typ	20 $^{\circ}$ C rise	40 $^{\circ}$ C rise	
FEXL1060A-R68M	0.68	1.50	50.0	55.0	22.5	34.0	9.5
FEXL1060A-1R0M	1.00	2.32	44.0	48.0	20.0	28.5	9.0
FEXL1060A-1R2M	1.20	2.64	40.0	45.0	18.0	26.5	9.0
FEXL1060A-1R5M	1.50	3.30	36.0	40.0	16.0	24.5	9.0
FEXL1060A-2R2M	2.20	4.84	30.0	35.0	14.0	20.0	9.0
FEXL1060A-3R3M	3.30	7.70	25.0	28.0	11.4	16.8	9.0
FEXL1060A-4R7M	4.70	10.72	22.0	25.0	8.7	14.0	9.0

FEXL1580A series

Part No.	L0 (μH)±20 %	DCR (mΩ) MAX	Isat (A)		Irms (A)Typ	
			Max	Typ	20℃ rise	40℃ rise
FEXL1580A-2R0M	2.00	2.21	52.0	57.0	29.5	40.0
FEXL1580A-2R2M	2.20	2.48	49.0	55.0	28.0	37.0
FEXL1580A-3R0M	3.00	3.00	41.0	46.0	26.0	34.5
FEXL1580A-4R2M	4.20	4.68	33.0	38.0	20.5	27.0
FEXL1580A-5R3M	5.30	5.34	31.0	35.0	19.5	26.0
FEXL1580A-6R2M	6.20	6.50	31.0	34.0	17.0	23.0
FEXL1580A-7R2M	7.20	7.20	29.0	32.0	15.0	21.0
FEXL1580A-8R2M	8.20	7.92	25.0	28.0	13.0	19.0

FEXL1510A series

Part No.	L0 (μH)±20 %	DCR (mΩ) MAX	Isat (A)		Irms (A)Typ	
			Max	Typ	20℃ rise	40℃ rise
FEXL1510A-4R7M	4.7	3.8	39	43	22.0	30.0
FEXL1510A-5R6M	5.6	4.2	34	38	21.0	28.0
FEXL1510A-6R8M	6.8	4.6	31.0	36.0	20.0	26.0
FEXL1510A-8R2M	8.2	7.2	28.0	32.0	19.0	25.0
FEXL1510A-100M	10	8.6	26	29	18	24
FEXL1510A-150M	15	11.5	18	20	14	18

FEXL1513A series

Part No.	L0 (μH)±20 %	DCR (mΩ) MAX	Isat (A)		Irms (A)Typ	
			Max	Typ	20℃ rise	40℃ rise
FEXL1513A-4R7M	4.7	3.3	40.0	44.0	23.0	31.0
FEXL1513A-5R6M	5.6	3.9	35.0	40.0	22.0	29.0
FEXL1513A-6R8M	6.8	4.2	32.0	37.0	21.0	27.0
FEXL1513A-8R2M	8.2	5.74	29.0	33.0	20.0	26.0
FEXL1513A-100M	10	7.0	27.0	30.0	19.0	25.0
FEXL1513A-150M	15	7.5	21.0	25.5	16.0	22.0
FEXL1513A-220M	22	13.86	19.0	22.0	12.0	17.0
FEXL1513A-330M	33	22.2	16.0	19.0	9.0	14.0

Notes:

1. Test frequency : L : 100KHz /0. 1V;
2. All test in 25 °C temperature.
3. Testing Instrument:L:HP4285A,CH11025,CH3302,CH1320,CH1320S LCR METER / Rdc:CH16502, MICRO OHMMETER.
4. Heating Rating Current (I_{rms}) will cause the coil temperature rise of 40 °C approximately (Δt):
5. Saturation Current (I_{sat}) will cause L₀ to drop 30% approximately.
6. The part temperature (ambient + temp rise) should not exceed 125 °C under the worst case operating condition. Circuit design, component, PCB trace size and thickness airflow and other cooling provisions all could affect the part temperature. Part temperature should be verified in the end application.
7. Special inquiries besides the above common used types can be met on your requirement.
8. For FEXL series inductors, absolute maximum voltage: DC 30V



DCR Test

Mechanical Reliability		
Item	Specification and Requirement	Test Method
Solderability	1. No case deformation or change in visual 2. New solder coverage More than 95%	1.Preheat: 155℃±5℃ , 60S±2S 2.Tin: lead-free. 3.Temperature:240℃±5℃ , flux 3.0S±0.5S.
Mechanical shock	1. No case deformation or change in visual 2. $\Delta L/L_0 \leq \pm 10\%$	1. Acceleration: 100G 2. Pulse time: 6ms 3. 3 times in each positive and negative direction of 3 mutual perpendicular directions
Mechanical vibration	1. No case deformation or change in visual 2. $\Delta L/L_0 \leq \pm 10\%$	1. Reflow: 2times 2. Frequency: 10HZ~50HZ~10HZ , 20 Min/Cycles 3. Amplitude: 1.52 mm±10% 4. Directions: X,Y,Z 5. Time: 12 cycle / direction
Endurance Reliability		
Item	Specification and Requirement	Test Method
Thermal Shock	Inductance change: Within $\pm 10\%$ Without distinct damage in visual	1. First -55℃ for 30 minutes , last 125℃ for 30 minutes as 1 cycle. Go through 1000 cycles. 2. Max transfer time is 3 minutes. 3. Measured at room temperature after placing for 24±2 hours
Humidity Resistance	Inductance change: Within $\pm 10\%$ Without distinct damage in visual	1.Reflow 2 times, 2.85℃±3℃,85%±3%RH, 1000 hours 3.Measured at room temperature after placing for 24±2 hours
Low temperature storage	Inductance change: Within $\pm 10\%$ Without distinct damage in visual	1. Temperature: -55 ± 2℃ 2. Time: 1000 hours 3. Measured at room temperature after placing for 24±2 hours
High temperature storage	Inductance change: Within $\pm 10\%$ Without distinct damage in visual	1. Temperature: +125 ± 2℃ 2. Time: 1000 hours 3. Measured at room temperature after placing for 24±2 hours

Recommended Soldering Technologies

(1) Re-flowing Profile

Preheat condition: 150 ~200°C/60~120sec.

Allowed time above 217°C: 60~90sec.

Peak temp: 260°C

Max time at Peak temp: 10 sec.

Solder paste: Sn/3.0Ag/0.5Cu

Allowed Reflow time: 2x max



(2) Iron Soldering Profile

Iron soldering power: Max. 30W

Pre-heating: 150°C/60sec.

Soldering Tip temperature: 350°C Max.

Soldering time: 3sec. Max.

Solder paste: Sn/3.0Ag/0.5Cu

Max. 1 times for iron soldering

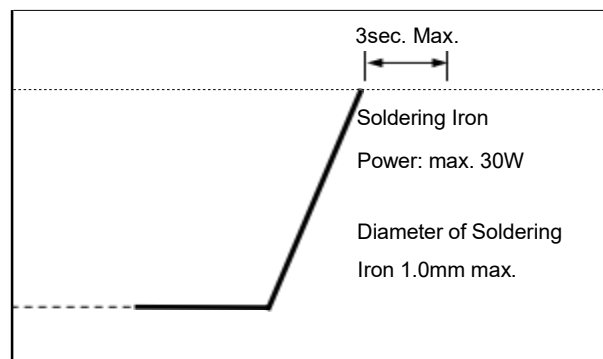

Packaging Information

(1) Tape Packaging Dimensions (Unit: mm)

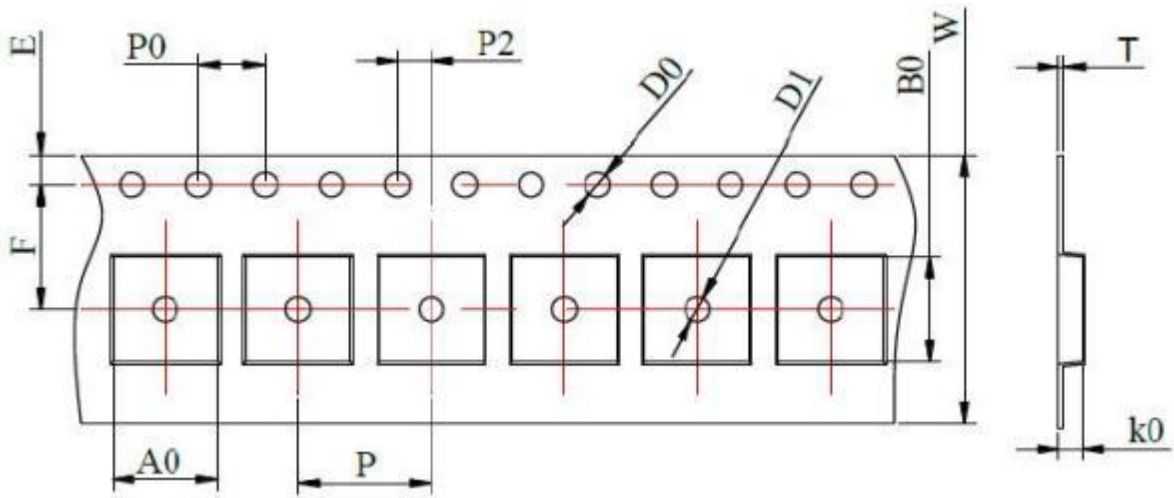

Taping Drawings (UNIT:mm)



Type	Tape dimensions (mm)											
	W	P	P0	P2	D0	D1	T	A0	B0	K0	E	F
FEXL0420A	12 ±0.3	8 ±0.1	4 ±0.1	2 ±0.1	1.5 ±0.1	1.5 ±0.1	0.35 ±0.05	4.4 ±0.1	4.4 ±0.1	2.3 ±0.1	1.75 ±0.1	5.5 ±0.1
FEXL0430A	12 ±0.3	8 ±0.1	4 ±0.1	2 ±0.1	1.5 ±0.1	1.5 ±0.1	0.35 ±0.05	4.4 ±0.1	4.4 ±0.1	3.3 ±0.1	1.75 ±0.1	5.5 ±0.1
FEXL0520A	12 ±0.3	8 ±0.1	4 ±0.1	2 ±0.1	1.5 ±0.1	1.5 ±0.1	0.35 ±0.05	6 ±0.1	5.7 ±0.1	2.3 ±0.1	1.75 ±0.1	5.5 ±0.1
FEXL0530A	16 ±0.3	8 ±0.1	4 ±0.1	2 ±0.1	1.5 ±0.1	1.5 ±0.1	0.35 ±0.05	6 ±0.1	5.7 ±0.1	3.3 ±0.1	1.75 ±0.1	7.5 ±0.1
FEXL0550A	16 ±0.3	8 ±0.1	4 ±0.1	2 ±0.1	1.5 ±0.1	1.5 ±0.1	0.35 ±0.05	6.0 ±0.1	5.7 ±0.1	5.3 ±0.1	1.75 ±0.1	7.5 ±0.1
FEXL0630A	16 ±0.3	12 ±0.1	4 ±0.1	2 ±0.1	1.5 ±0.1	1.5 ±0.1	0.35 ±0.05	7.0 ±0.1	6.8 ±0.1	3.3 ±0.1	1.75 ±0.1	7.5 ±0.1
FEXL0650A	16 ±0.3	12 ±0.1	4 ±0.1	2 ±0.1	1.5 ±0.1	1.5 ±0.1	0.35 ±0.05	7.0 ±0.1	6.8 ±0.1	5.3 ±0.1	1.75 ±0.1	7.5 ±0.1
FEXL0660A	16 ±0.3	12 ±0.1	4 ±0.1	2 ±0.1	1.5 ±0.1	1.5 ±0.1	0.35 ±0.05	7.0 ±0.1	6.8 ±0.1	6.3 ±0.1	1.75 ±0.1	7.5 ±0.1
FEXL0720A	16 ±0.3	12 ±0.1	4 ±0.1	2 ±0.1	1.5 ±0.1	1.5 ±0.1	0.35 ±0.05	8.2 ±0.1	8.0 ±0.1	2.3 ±0.1	1.75 ±0.1	7.5 ±0.1
FEXL0730A	16 ±0.3	12 ±0.1	4 ±0.1	2 ±0.1	1.5 ±0.1	1.5 ±0.1	0.35 ±0.05	8.2 ±0.1	8.0 ±0.1	3.3 ±0.1	1.75 ±0.1	7.5 ±0.1
FEXL0770A	16 ±0.3	12 ±0.1	4 ±0.1	2 ±0.1	1.5 ±0.1	1.5 ±0.1	0.35 ±0.05	8.2 ±0.1	8.0 ±0.1	7.3 ±0.1	1.75 ±0.1	7.5 ±0.1
FEXL0880A	24 ±0.3	16 ±0.1	4 ±0.1	2 ±0.05	1.5 ±0.1	1.5 ±0.1	0.35 ±0.05	9.4 ±0.1	8.9 ±0.1	8.5 ±0.1	1.75 ±0.1	11.5 ±0.1
FEXL1010A	24 ±0.3	16 ±0.1	4 ±0.1	2 ±0.05	1.5 ±0.1	1.5 ±0.1	0.35 ±0.05	12.4 ±0.1	11.5 ±0.1	10.3 ±0.1	1.75 ±0.1	11.5 ±0.1
FEXL1031A	24 ±0.3	16 ±0.1	4 ±0.1	2 ±0.05	1.5 ±0.1	1.5 ±0.1	0.35 ±0.05	12.4 ±0.1	11.5 ±0.1	3.3 ±0.1	1.75 ±0.1	11.5 ±0.1
FEXL1060A	24 ±0.3	16 ±0.1	4 ±0.1	2 ±0.05	1.5 ±0.1	1.5 ±0.1	0.35 ±0.05	12.4 ±0.1	11.5 ±0.1	6.3 ±0.1	1.75 ±0.1	11.5 ±0.1
FEXL1510A	32 ±0.3	24 ±0.1	4.0 ±0.1	2.0 ±0.1	1.5 ±0.1	1.5 ±0.1	0.5 ±0.05	17 ±0.1	16 ±0.1	10.5 ±0.1	1.75 ±0.1	14.2 ±0.1
FEXL1513A	32 ±0.3	24 ±0.1	4.0 ±0.1	2.0 ±0.1	1.5 ±0.1	1.5 ±0.1	0.5 ±0.05	17 ±0.1	16 ±0.1	13.6 ±0.1	1.75 ±0.1	14.2 ±0.1
FEXL1580A	32 ±0.3	24 ±0.1	4.0 ±0.1	2.0 ±0.1	1.5 ±0.1	1.5 ±0.1	0.5 ±0.05	17 ±0.1	16 ±0.1	8.5 ±0.1	1.75 ±0.1	14.2 ±0.1

(2) Reel Dimensions (Unit: mm)



Type	A	W	N	B	C
FEXL0420A	330+2.0	12.8±0.2	97±0.5	2.2+0.5	13.0±0.2
FEXL0430A	330+2.0	12.8±0.2	97±0.5	2.2+0.5	13.0±0.2
FEXL0520A	330+2.0	12.8+0.2	97+0.5	2.2+0.5	13.2±0.2
FEXL0530A	330+2.0	16.8+0.2	97+0.5	2.2+0.5	13.2±0.2
FEXL0550A	330+2.0	16.8+0.2	97+0.5	2.2+0.5	13.2±0.2
FEXL0630A	330+2.0	16.8+0.2	97+0.5	2.2+0.5	13.2±0.2
FEXL0650A	330+2.0	16.8+0.2	97+0.5	2.2+0.5	13.2±0.2
FEXL0660A	330+2.0	16.8+0.2	97+0.5	2.2+0.5	13.2±0.2
FEXL0720A	330+2.0	16.8+0.2	97+0.5	2.2+0.5	13.2±0.2
FEXL0730A	330+2.0	16.8+0.2	97+0.5	2.2+0.5	13.2±0.2
FEXL0770A	330+2.0	16.8±0.5	97±0.5	2.2+0.5	132±0.2
FEXL0880A	330+2.0	24±0.5	97±0.5	2.2+0.5	13.0±0.2

FEXL1010A	330+2.0	24±0.5	97±0.5	2.2+0.5	13.0±0.2
FEXL1031A	330+2.0	24±0.5	97±0.5	2.2+0.5	13.0±0.2
FEXL1060A	330+2.0	24±0.5	97±0.5	2.2+0.5	13.0±0.2
FEXL1510A	330+2.0	32±0.5	97±0.5	2.2+0.5	13.0±0.2
FEXL1513A	330+2.0	32±0.5	97±0.5	2.2+0.5	13.0±0.2
FEXL1580A	330+2.0	32±0.5	97±0.5	2.2+0.5	13.0±0.2

(3)Packaging Quantity

Type	Standard Quantity		
	Reel	Inner box	Carton box
FEXL0420A	3000 pcs / reel	4Reel / box (12000 pcs)	3Middle boxes, (36,000 pcs)
FEXL0430A	3000 pcs / reel	4Reel / box (12000 pcs)	3Middle boxes, (36,000 pcs)
FEXL0520A	3000 pcs / reel	3Reel / box (9000 pcs)	3 Middle boxes, (27,000 pcs)
FEXL0530A	2000 pcs / reel	3Reel / box (6000 pcs)	3 Middle boxes, (18,000 pcs)
FEXL0550A	1500 pcs / reel	3Reel / box (4500 pcs)	3 Middle boxes, (13,500 pcs)
FEXL0630A	1000 pcs / reel	3Reel / box (3000 pcs)	3 Middle boxes, (9,000 pcs)
FEXL0650A	1000 pcs / reel	3Reel / box (3000 pcs)	3 Middle boxes, (9,000 pcs)
FEXL0660A	750 pcs / reel	3Reel / box (2250 pcs)	3 Middle boxes, (6,750 pcs)
FEXL0720A	2000pcs / reel	3Reel / box (6000 pcs)	3 Middle boxes, (18000 pcs)
FEXL0730A	1500 pcs / reel	3Reel / box (4500 pcs)	3 Middle boxes, (13,500 pcs)

FEXL0770A	750 pcs / reel	3Reel / box (2250 pcs)	3 Middle boxes, (6,750 pcs)
FEXL0880A	450pcs / reel	2Reel / box (900 pcs)	3 Middle boxes, (2700 pcs)
FEXL1010A	300 pcs / reel	2Reel / box (600 pcs)	3 Middle boxes, (1800 pcs)
FEXL1031A	300 pcs / reel	2Reel / box (600 pcs)	3 Middle boxes, (1800 pcs)
FEXL1060A	500 pcs / reel	2Reel / box (1000 pcs)	3 Middle boxes, (3000 pcs)
FEXL1510A	150 pcs / reel	2Reel / box (300 pcs)	3 Middle boxes, (900 pcs)
FEXL1513A	100 pcs / reel	2Reel / box (200 pcs)	3 Middle boxes, (600 pcs)
FEXL1580A	200 pcs / reel	2Reel / box (400 pcs)	3 Middle boxes, (1200 pcs)

(4) Peel force of top cover tape

The peel speed shall be about 300mm/minute

The peel force of top cover tape shall be between 0. 1 to 1.3 N

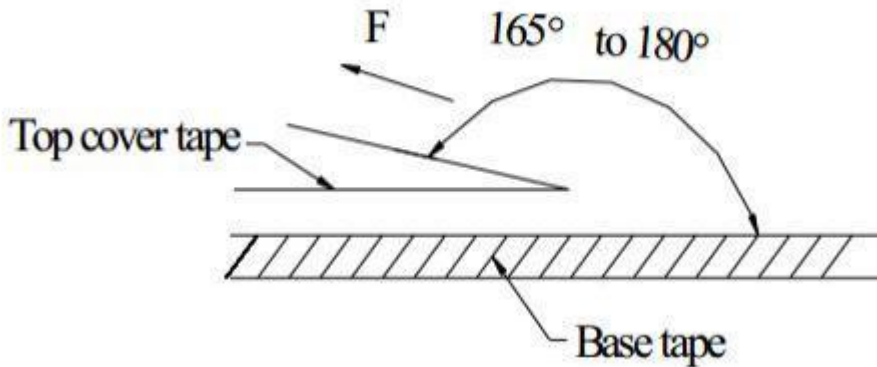

(5) Reel Label

Label on the reel

- Customer's part Number
- Lot Number
- Quantity
- date code

Shipping Label

- Customer's part Number
- Manufacturer's part Number
- Quantity
- date code



(6) Inner Box

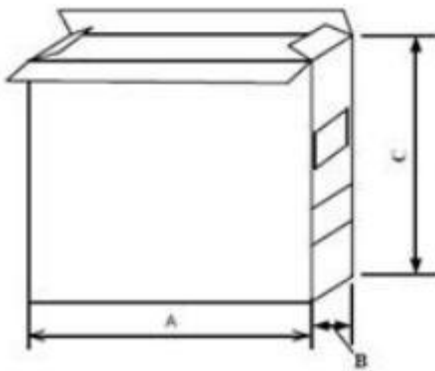

Packaging type	A (mm)	B (mm)	B (mm)
inner box	354	335	86

(7) Carton

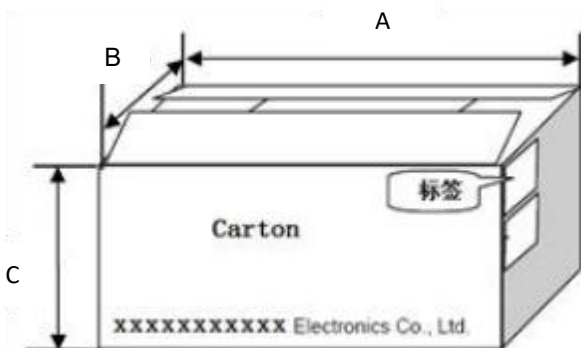

Packaging type	A (mm)	B (mm)	B (mm)
type	370	365	285

Appearance criterion

1 、 PAD residual powder 、 inner wire exposed 、 imprinting

The residual powder on both side of pad is norm and within following criteria are acceptable.

The imprinting mark below the part, are norm in manufacturing process and does not affect the function and it is acceptable.

Front lit imprinting is acceptable.

a	10% max of the length of pad.
b	5% of the area on one single pad.
t	0.08mm max.

Foreign materials on the product body is inevitable and accepted.

2 、 Defects

Chip off is generated during molding and manufacturing process .

Chip off acceptance limits subjected to the product size .

Our current Defect limit is based on the IPC- A- 6 1 0 .

Some chip off does not impact the product function, see the IPC standard 1 & 2 .

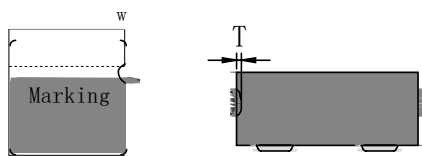

T	≤ 10% of the thickness	Each surface can only accept one minor chip off , and more than 3 chip off problems are not allowed on the same product.
W	≤ 10 % of the width	
L	≤ 10 % of the length	

Defects usually occur at the corners and edges of the product, There will be a slight defect black and rough, but not exposed copper, and does not affect the product performance and reliability.

3 、 Crack

Production process of cracks appearing in the body is inevitable, some slight crack is caused because the molding, is not oxidized, crack on the product will not affect product performance.

We have done a reliability test of crack products , even if cracks is more than 0 . 1 3 mm also will not affect the electrical properties of the product, crack limits as follows:

Severely crack: not acceptable. More obvious cracks extended from side to side.

Moderate crack: not acceptable. Very obvious and may result in powder come off and exposed of copper wire.

Slight crack: acceptable.

Slight wire expose: acceptable. wire exposed during Press process.

Lead wire imprint: acceptable. Turns of wires that close to the edge and imprint show.

Products from a slight crack in the baking process due to thermal expansion, and it is not obvious by visual inspection (Must not exceed the blue square area).

Cracks on the same side surface are not allowed to exceed 1/2 of the length of the side and the crack width cannot exceed 0. 13mm, and only 1 crack is allowed on the same side.

Bottom cracks are not allowed to exceed 1/2 of the length (or width) of the corresponding body nor the Non-manufacturability swelling, and the crack width cannot be exceed 0. 13mm, and less than 2 cracks are allowed and judged as good products.

Visible cracks and non-manufacturability bulging are not allowed on the front side.

4 、 oxidation(rust)

the contains iron composite, although the resin has a protective effect of oxidation, but there will be small amount of product that may occur oxidation, The oxidation area of each surface is allowed to be about 25% (in the case of non-reliability test), it is recommend that customer use this product in humidity controlled environment. The basic steps should be to protect the surface oxidation, including the sealed packages to PCB mount inductors. To avoid the adverse effects caused by oxidation, Oxidation occurs at the surface only allows the internal oxidation is not allowed, oxidized surface will not affect the reliability of the product.



can be accepted if recognizable

Visual inspection: Examination with the naked eye, to distinguish from more technical modes of analysis employing tools or apparatus.

X-ON Electronics

Largest Supplier of Electrical and Electronic Components

Click to view similar products for [Fixed Inductors](#) category:

Click to view products by [Changjiang Microelectronics](#) manufacturer:

Other Similar products are found below :

[CR32NP-100KC](#) [70F224AI](#) [MHQ1005P10NJ](#) [MHQ1005P1N0S](#) [MHQ1005P2N4S](#) [MHQ1005P3N6S](#) [MHQ1005P5N1S](#) [MHQ1005P8N2J](#)
[PE-53601NL](#) [PE-53602NL](#) [PG0936.113NLT](#) [9220-20](#) [9310-16](#) [PM06-2N7](#) [PM06-39NJ](#) [A01TK](#) [1206CS-471XJ](#) [HC2-R47-R](#) [HC8-1R2-R](#)
[HCF1305-3R3-R](#) [1206CS-151XG](#) [RCH664NP-4R7M](#) [RCP1317NP-391L](#) [DH2280-4R7M](#) [DS1608C-106](#) [B10TJ](#) [B82498B3101J000](#) [ELJ-](#)
[RE27NJF2](#) [1812CS-153XJ](#) [1812CS-183XJ](#) [1812CS-223XJ](#) [1812LS-104XJ](#) [1812LS-105XJ](#) [1812LS-124XJ](#) [1812LS-154XJ](#) [1812LS-223XJ](#)
[1812LS-224XJ](#) [1812LS-563XJ](#) [1812LS-683XJ](#) [1812LS-824XJ](#) [NIN-FB101JTR110F](#) [NIN-FB471JTR62F](#) [NIN-FC1R5JTR220F](#) [NIN-](#)
[HCR15JTRF](#) [NIN-HCR33JTRF](#) [NIN-HDR22JTRF](#) [NIN-HDR82JTRF](#) [NIN-HK2N7STRF](#) [NIN-PA150KTR370F](#) [NIN-PB100KTR550F](#)