

Specification of Cjiang products

Customer	
Product Name	Wire Wound Molded SMD Power Inductors
Customer P/N:	
Cjiang P/N:	FPB201612D-1R5MT2

[New Released, Revised]

SPEC No:

REMARK:		
Customer Approval Feedback		

●深圳市长江微电科技有限公司

SZ CJIANG TECHNOLOGY CO.,LTD

ADD: 11F, International Science and Technology Building, Fuhong Road, Futian District, Shenzhen

Factory ADD:No. shanyang RD CJIANG Industrial Park HUAI'AN Section HUAI'AN City Jiangsu Province

TEL: 0755-82529562 FAX:0755-83977004

<http://www.CJIANG.COM.CN>

SALES: E-mail: BOND@cjiang.com.cn; ann@cjiang.com.cn

R&D: E-mail: LZJ@cjiang.com.cn

Version change history

Rev	Date	Description	APPROVED	CHECKED	DRAWN
1.0	2024/6/28	Document formulation	BOND	MIKO	Roy

Caution :

All products listed in this specification are developed, designed and intended for use in general electronics equipment. The products are not designed or Warranted to meet the requirements of the applications listed below, whose performance and/or quality require especially high reliability, or whose failure, malfunction or trouble might directly cause damage to society, person, or property. Please understand that we are not responsible for any damage or liability caused by use of the products in any of the applications below. Please contact us for more details if you intend to use our products in the following applications.

1. Aircraft equipment.
2. Aerospace equipment.
3. Undersea equipment.
4. nuclear control equipment.
5. military equipment.
6. Power plant equipment.
7. Medical equipment.
8. Transportation equipment (automobiles, trains, ships,etc.)
9. Traffic signal equipment.
10. Disaster prevention / crime prevention equipment.
11. Data-processing equipment.
12. Applications of similar complexity or with reliability requirements comparable to the applications listed in the above.

电感 / Inductor

1. Features

- High magnetic flux saturation density characteristics by metal magnetic material.
- Low DC resistance by flat wire and achieve high conversion efficiency and lower temperature rising.
- Magnetically shielded structure to accomplish high resolution in EMC protection.
- High mounting stability due to Chip shape.
- High reliability by original structure.
- Halogen free, Lead free. RoHS Compliance.

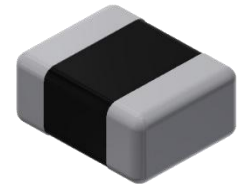

2. Application

- DC/DC converter
- Smart phone/PAD, HDD/SSD, DVC/DSC
- mobile display panels, portable game devices, compact power supply modules, other.

3. Part Number Construction

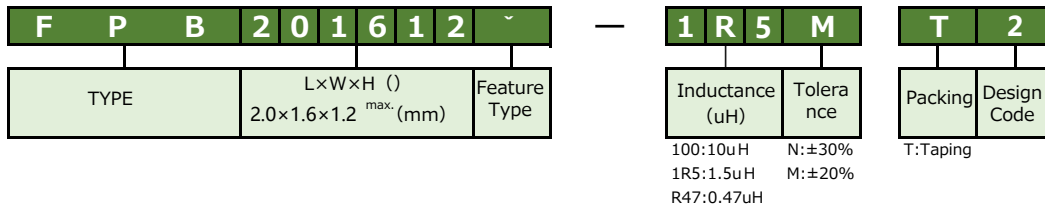

4. Characteristics Specification Table

Part No.	L (uH)	Tolerance	Rdc (mΩ) Max.[Typ.]	I _{sat} (A) Max.[Typ.]	I _{temp} (A) Max.[Typ.]
FPB201612D-1R5MT2	1.5	±20%	72 [62]	2.9 [3.3]	2.3 [2.7]

- Test frequency at 1MHz, OSC LEVEL: 0.5V
- Inductance is measured with Keysight Technologies LCR meter 4285A. Equivalent measurement equipment may be used.
- Rated current: smaller value of either Isat or Itemp.
- Isat: When based on the inductance change rate (30% below the initial L value) or secure 65% of the nominal L value.
- Itemp: When based on the temperature increase (temperature increase of 40°C by self heating).
 - ※ Itemp is a reference value according to our usage environment.
 - ※ In the end application, the circuit design should be such that the part temperature rise does not exceed 40 °C.
- Withstand DC Voltage : 20[V]

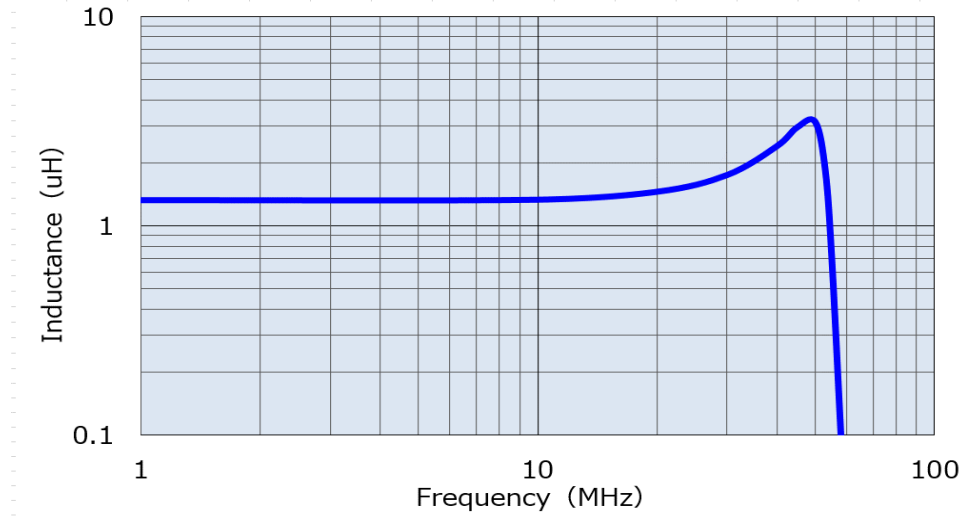

4294A (Keysight Technologies)

6. Inductance vs. DC Bias Characteristics

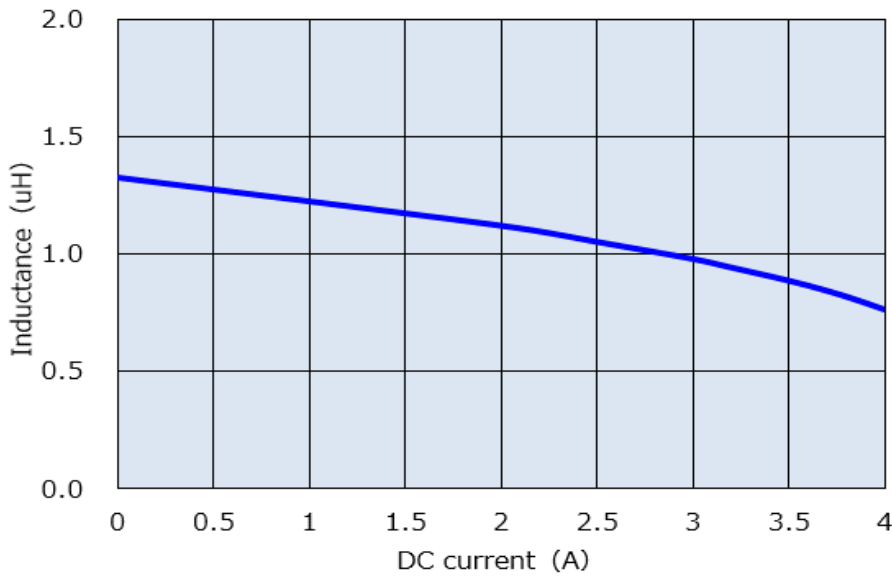

4285A + 42841A + 42842C
(Keysight Technologies)

7. Shape & Dimensions

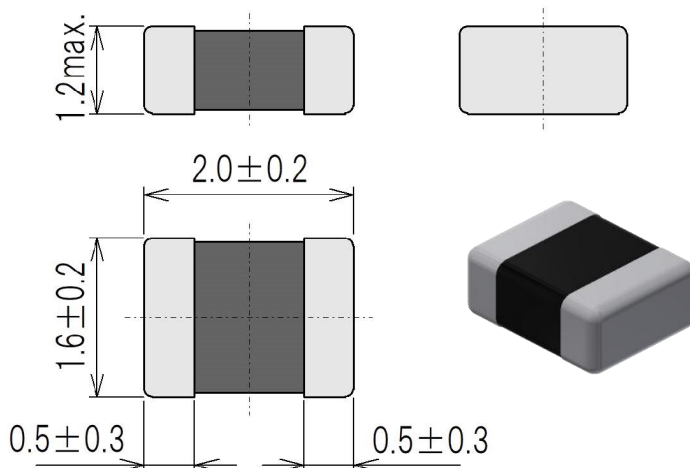

Dimensions in mm

FPB201612D-1R5MT2 / SMD E2

8. Packaging Style

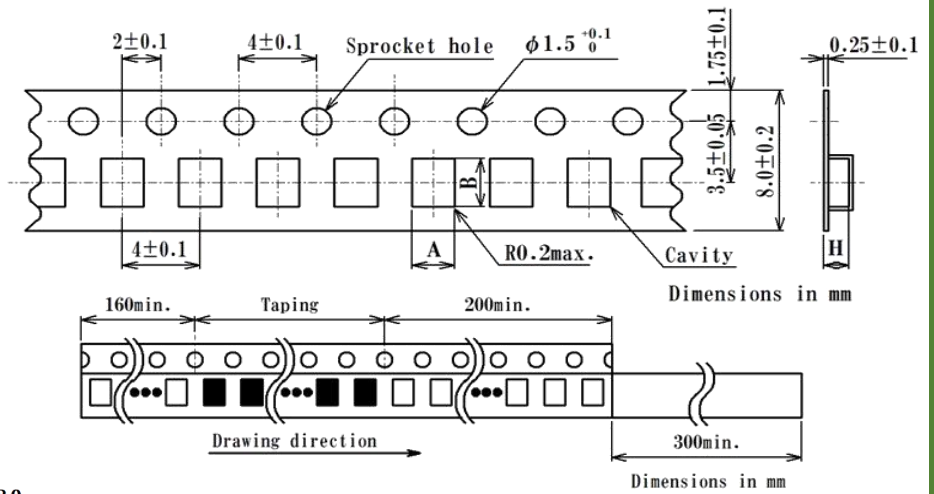
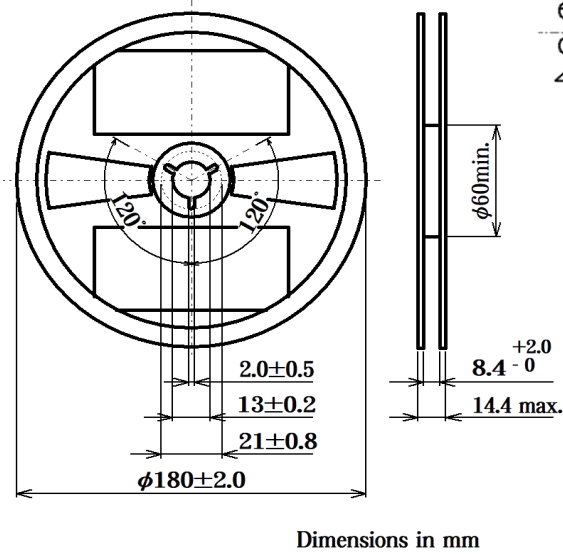

Series	A	B	H	(pcs/reel)	(g/reel)
FPB201612D-1R5MT2	1.90±0.1	2.30±0.1	1.3±0.1	3,000	140±10

※ A & B MEASUREMENT POINT TO BE 0.20mm FROM BOTTOM POCKET.

Packing Box

Box Name	Size(cm)	Weight(g)
120K Inner Packing Box	39*29*21.5	433±20
120K Outer Packing Box	41*31*24.5	503±20
60K Inner Packing Box	29*20*21.5	229±20
60K Outer Packing Box	31*22*24.5	299±20
15K Packing Box	19.8*18.8*7	76±20

9. Recommended Land Pattern

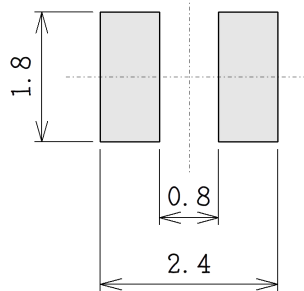

10. Recommended Reflow Profile

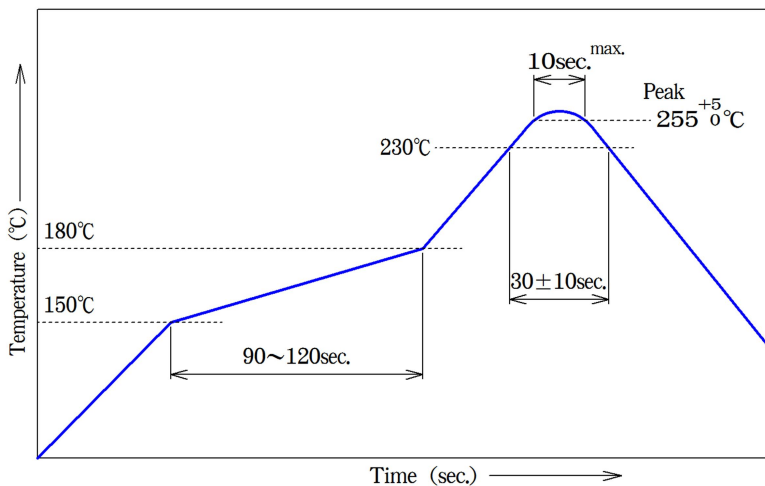

11. Reliability and Test Condition

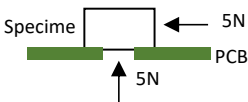
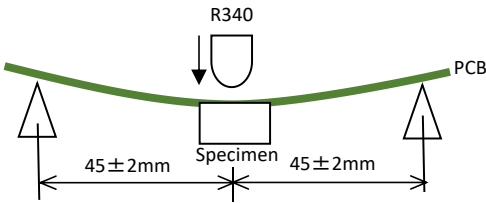
Test item	Test condition	Specification
Adhesive Test	<ul style="list-style-type: none"> • Test time: 10±1sec. • Measure after removing pressure. 	<ul style="list-style-type: none"> • $\Delta L/L$: within $\pm 10\%$ (Change from an initial value) • No abnormal appearance after the test.
Bending test	<ul style="list-style-type: none"> • Bent depth : 2mm • PCB size: 40×100mm • PCB thickness: 1.0mm • Test time: 30sec. 	<ul style="list-style-type: none"> • $\Delta L/L$: within $\pm 10\%$ (Change from an initial value) • No abnormal appearance after the test.
Vibration test	<ul style="list-style-type: none"> • Sweep frequency : 10~55Hz (10Hz to 55Hz to 10Hz in a period of one minute) • Amplitud : 1.5mm • 2Hr in each of 3(X, Y, Z) axes. 	<ul style="list-style-type: none"> • $\Delta L/L$: within $\pm 10\%$ (Change from an initial value) • No abnormal appearance after the test.
Mechanical shock test	<ul style="list-style-type: none"> • Peak acceleration : 1962m/s² • Duration of pulse : 6ms • 3 times in each of 3(X, Y, Z) axes. 	<ul style="list-style-type: none"> • $\Delta L/L$: within $\pm 10\%$ (Change from an initial value) • No abnormal appearance after the test.
Drop test	<ul style="list-style-type: none"> • The specimen must be fixed on PCB. It must be equipped with instruments of which weight is 500g. Then it shall be fallen freely from 100cm height to rigid wood 3 times in each of three axes. 	<ul style="list-style-type: none"> • $\Delta L/L$: within $\pm 10\%$ (Change from an initial value) • No abnormal appearance after the test.
Resistance to Solder Heat	<ul style="list-style-type: none"> • Reflow soldering method Preheat : 150~180°C 90±30sec. Peak temp. : 255(+5/-0)°C (230°Cmin., 30±10sec.) • PCB thickness: 1.0mm • 2times 	<ul style="list-style-type: none"> • $\Delta L/L$: within $\pm 10\%$ (Change from an initial value) • No abnormal appearance after the test.
Solder ability	<ul style="list-style-type: none"> • Electrode shall be immersed in flux at room temperature and then shall be immersed in solder bath after preheat. • Solder temp: 245±5°C. Dip time: 3±0.5sec. 	<ul style="list-style-type: none"> • New solder shall cover 90% minimum of the surface immersed.
Temperature drift	<ul style="list-style-type: none"> • To be measured in the range of -40°C to 125°C. 	<ul style="list-style-type: none"> • Inductance temperature coefficient 1000ppm/°C or less.

Temperature Test

Test item	Test condition	Specification															
Low temperature test	<ul style="list-style-type: none"> Temp.: -40±3℃ Load : 500±12Hr 	<ul style="list-style-type: none"> ΔL/L : within ± 10% (Change from an initial value) No abnormal appearance after the test. 															
Dry heat test	<ul style="list-style-type: none"> Temp.: +85±2℃ Load : 500±12Hr 	<ul style="list-style-type: none"> ΔL/L : within ± 10% (Change from an initial value) No abnormal appearance after the test. 															
Humidity test	<ul style="list-style-type: none"> Temp.: +40±2℃ Humidity : 90~95%RH Load : 500±12Hr 	<ul style="list-style-type: none"> ΔL/L : within ± 10% (Change from an initial value) No abnormal appearance after the test. 															
Thermal shock test	<ul style="list-style-type: none"> Condition of 1 cycle <table border="1" style="margin-left: 40px;"> <thead> <tr> <th>Step</th> <th>(℃) Temp.</th> <th>(min.) Duration</th> </tr> </thead> <tbody> <tr> <td>1</td> <td>-40±3</td> <td>30±3</td> </tr> <tr> <td>2</td> <td>Room temp.</td> <td>Within 3</td> </tr> <tr> <td>3</td> <td>+125±2</td> <td>30±3</td> </tr> <tr> <td>4</td> <td>Room temp.</td> <td>Within 3</td> </tr> </tbody> </table> <ul style="list-style-type: none"> Load : 100±12cycle 	Step	(℃) Temp.	(min.) Duration	1	-40±3	30±3	2	Room temp.	Within 3	3	+125±2	30±3	4	Room temp.	Within 3	<ul style="list-style-type: none"> ΔL/L : within ± 10% (Change from an initial value) No abnormal appearance after the test.
Step	(℃) Temp.	(min.) Duration															
1	-40±3	30±3															
2	Room temp.	Within 3															
3	+125±2	30±3															
4	Room temp.	Within 3															

12. Temperature Range

Operating Temperature range: -40℃ to +125℃

※Operating temperature range includes self-temperature rise.

※The part temperature (ambient + temp rise) should not exceed 125℃ under worst case operating conditions.

Circuit design, component placement, PCB trace size and thickness, airflow and other cooling provisions all affect the part temperature. Part temperature should be verified in the end application.

Taping Package Storage Temperature range: +5℃ to +40℃

13. Reminders

请依交货规格书的规定内使用
Do not use for a purpose outside of the contents regulated in the delivery specifications.

○ 额定电流

- 请勿超过额定电流使用。

Do not exceed the rated current.

如果使用超过额定电流，绝缘电阻可能会下降，并且可能会产生过热现象

If it is used exceeding the rated current, insulation resistance may decrease and excessive heat generation may occur.

如产品出现任何异常或故障，请务必在成品中添加适当的失效保护功能，以防止次生灾害的发生

In case of any abnormality or malfunction of our products, be sure to add the appropriate Fail safe function to the finished product to prevent secondary disasters.

○ 保管方法

- 存储期限不超过6个月。请务必遵循存储条件（温度：5至40°C，湿度：20至75% RH或更低）

The storage period is less than 6 months. Be sure to follow the storage conditions (temperature: 5 to 40°C, humidity: 20 to 75% RH or less).

如果超过存储期限，端子电极的焊接性能可能会恶化

If the storage period elapses, the soldering of the terminal electrodes may deteriorate

请避免在阳光直射、振动等场所保管。

Avoid storage in places subject to direct sunlight, vibration, etc.

请勿在受气体腐蚀影响的环境（氯气、酸、碱、硫化气体等）中使用、保管。

Do not use or store in an environment (chlorine gas, acid, alkali, sulfide gas, etc.) that is affected by gas corrosion.

○ 搬运

- 请勿产生过度的振动、冲击。

Please do not give excessive vibration and impact.

○ 基板安装

- 不要在线圈下方设计通孔或布线。

Do not design Through hole or Pattern under Coil.

请安排使线圈彼此不接触。

Please arrange so that Coil does not touch each other.

将电路板装入设备时，请确保不要因为螺钉紧固部位或类似原因导致板子变形而对线圈施加压力。

When incorporating the circuit board into the SET, be sure not to apply stress to the Coil due to distortion of the board due to Screw fastening part or the like.

请考虑线圈的自我发热进行热设计。

Self heating (temperature increase) occurs when the power is turned ON, so the tolerance should be sufficient for the set thermal design.

○ 焊锡修正方法

Soldering correction method ·

Pre Heat : 150°C 1分钟

焊接修正方法 · 预热：150°C，1分钟

烙铁头功率：80W以下

Soldering tip power: 80 W or less

烙铁头温度：不超过350°C

Soldering tip temperature: 350 °C or less

烙铁头直径：不超过Φ 3 mm

Soldering tip diameter: Φ 3 mm or less

· 修正作业时间：3秒以内

Correction work time: within 3 seconds

- 请使用腕带（带电状态下请勿触摸coil）。

Use a wrist band to discharge static electricity in your body through the grounding wire.

- 请不要让磁铁、带磁性的东西靠近。

Do not expose the products to magnets or magnetic fields.

- 关于树脂涂层，请注意树脂的选择，在安装的状态下实施可靠性评价。

For resin Coating, pay attention to resin selection and perform reliability evaluation in the mounted state.

- 本成品用于一般民生电子设备（家用产品、通讯设备、计算机设备、固态硬盘）等，这些产品未设计能被用在安全性和可靠性高度要求的领域。如下列举例：

The products listed on this catalog are intended for use in general electronic equipment (home appliances, telecommunications equipment, computer equipment) under a normal operation and use condition. The products are not designed or warranted to meet the requirements of the applications listed below, whose performance and/or quality require a more stringent level of safety or reliability, or whose failure, malfunction or trouble could cause serious damage to society, person or property.

航空/宇宙机器

医疗器械

发电控制用机器

原子能相关机器

Aerospace/aviation equipment

Medical equipment

Power-generation control equipment

Atomic energy-related equipment

军用机器

安全装置

海底作业用机器

交通工具控制机器

Military equipment

Safety equipment

Seabed equipment

Transportation control equipment

公共信息处理设备

运输设备（汽车、电动列车、船舶等）

防灾/防犯罪设备

其它不被视为通用应用的用途

Public information-processing equipment

Transportation equipment (cars, electric trains, ships, etc.)

Disaster prevention/crime prevention equipment

Other applications that are not considered general-purpose applications