

## TSOT-23-5L Plastic-Encapsulate Diodes

### BAP70Q GENERAL PURPOSE PIN DIODES

#### FEATURES

- Low diode capacitance
- Low diode forward resistance

#### MARKING

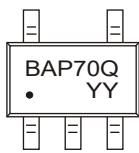

BAP70Q = Device code  
 Solid dot = Pin1 indicator  
 YY = Code

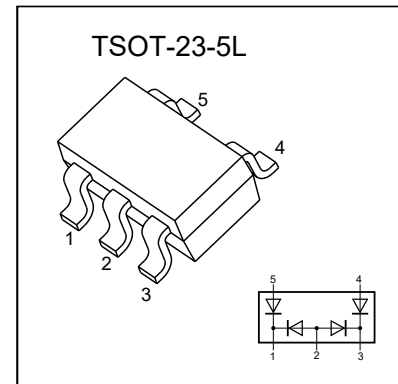

#### Maximum Ratings and Electrical Characteristics, Single Diode @Ta=25°C

Parameter	Symbol	Limit	Unit
Continuous Reverse Voltage	$V_R$	50	V
Continuous Forward Current	$I_F$	100	mA
Power Dissipation	$P_D$	125	mW
Thermal Resistance from Junction to Ambient	$R_{\theta JA}$	833	°C/W
Junction Temperature	$T_j$	-55~+150	°C
Storage Temperature	$T_{STG}$	-55~+150	°C

#### Electrical Ratings @Ta=25°C

Parameter	Symbol	Min	Typ	Max	Unit	Conditions
Continuous reverse voltage	$V_R$	50			V	$I_R=10\mu A$
Forward voltage	$V_F$		0.95	1.1	V	$I_F=50mA$
Reverse current	$I_R$			100	nA	$V_R=50V$
Diode capacitance	$C_{d1}$			0.91	pF	$V_R=0V, f=1MHz$
	$C_{d2}$			0.55	pF	$V_R=1V, f=1MHz$
	$C_{d3}$			0.35	pF	$V_R=5V, f=1MHz$
Diode forward resistance	$r_D$			40	$\Omega$	$I_F=0.5mA, f=100MHz; note1$
	$r_D$			25	$\Omega$	$I_F=1mA, f=100MHz; note1$
	$r_D$			5	$\Omega$	$I_F=10mA, f=100MHz; note1$

Note 1. Guaranteed on AQL basis: inspection level S4,AQL 1.0.

# Typical Characteristics

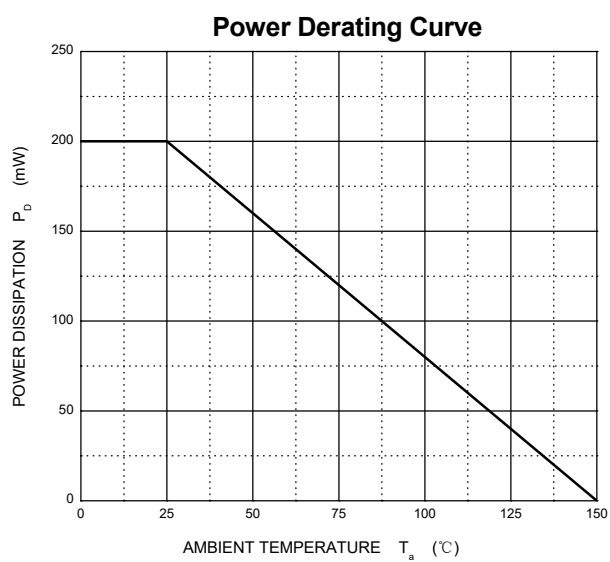
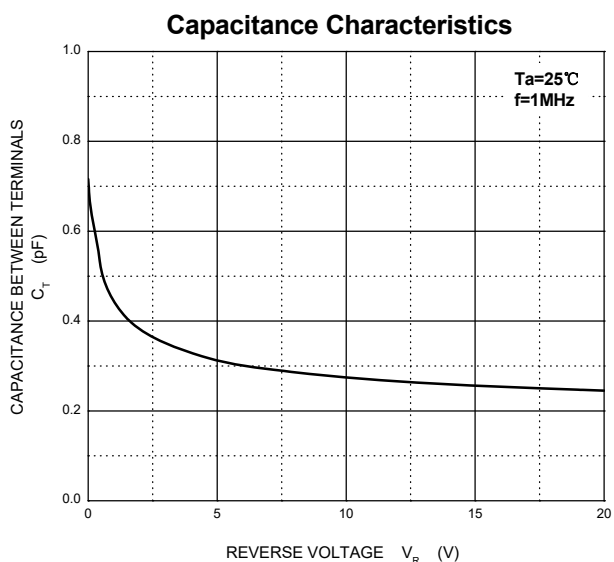
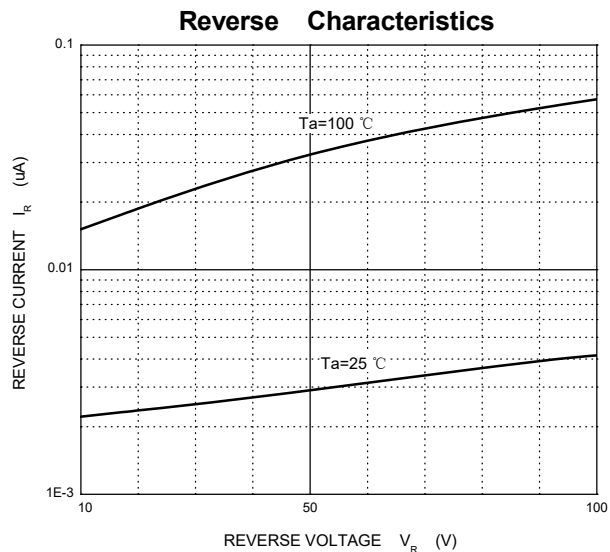
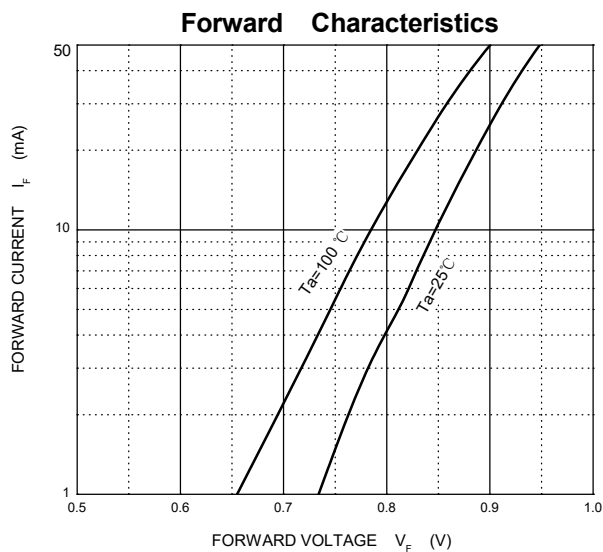

# TSOT-23-5L Package Outline Dimensions

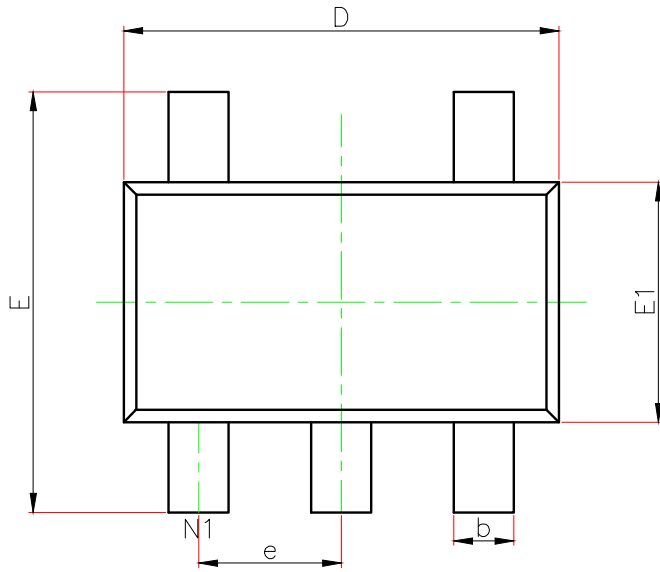

TOP VIEW

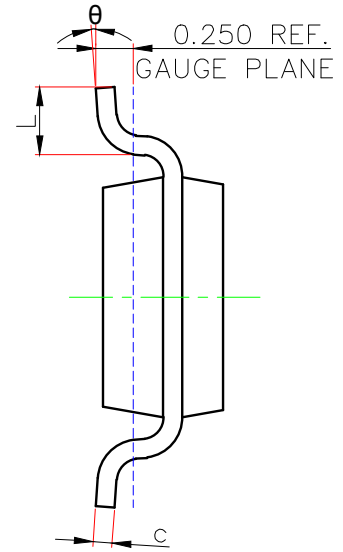

SIDE VIEW

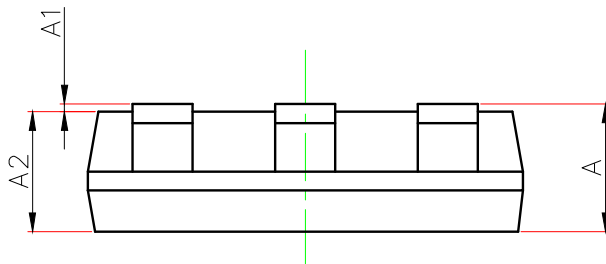

SIDE VIEW

Symbol	Dimensions In Millimeters		Dimensions In Inches	
	Min	Max	Min	Max
A	-----	1.100	-----	0.043
A1	0.000	0.100	0.000	0.004
A2	0.700	1.000	0.028	0.039
D	2.850	2.950	0.112	0.116
E	2.650	2.950	0.104	0.116
E1	1.550	1.650	0.061	0.065
b	0.300	0.500	0.012	0.020
c	0.080	0.200	0.003	0.008
e	0.950(BSC)		0.037(BSC)	
L	0.300	0.600	0.012	0.024
θ	0°	8°	0°	8°

### NOTICE

JSCJ reserves the right to make modifications, enhancements, improvements, corrections or other changes without further notice to any product herein. JSCJ does not assume any liability arising out of the application or use of any product described herein.

# TSOT-23-5L Tape and Reel

## TSOT-23-5L Embossed Carrier Tape

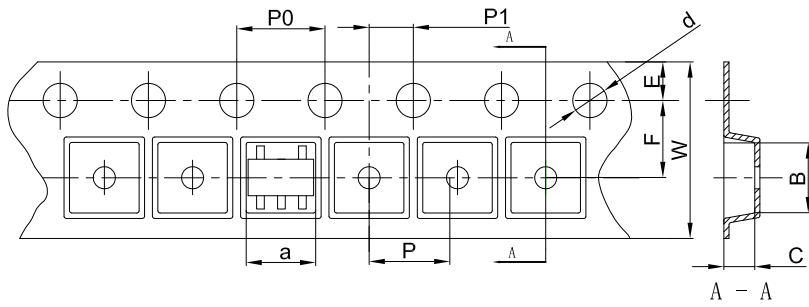

**Packaging Description:**

TSOT-23-5L parts are shipped in tape. The carrier tape is made from a dissipative (carbon filled) polycarbonate resin. The cover tape is a multilayer film (Heat Activated Adhesive in nature) primarily composed of polyester film, adhesive layer, sealant, and anti-static sprayed agent. These reeled parts in standard option are shipped with 3,000 units per 7" or 18.0cm diameter reel. The reels are clear in color and is made of polystyrene plastic (anti-static coated).

Dimensions are in millimeter										
Pkg type	a	B	C	d	E	F	P0	P	P1	W
TSOT-23-5L	3.17	3.23	1.37	Ø1.55	1.75	3.50	4.00	4.00	2.00	8.00

## TSOT-23-5L Tape Leader and Trailer

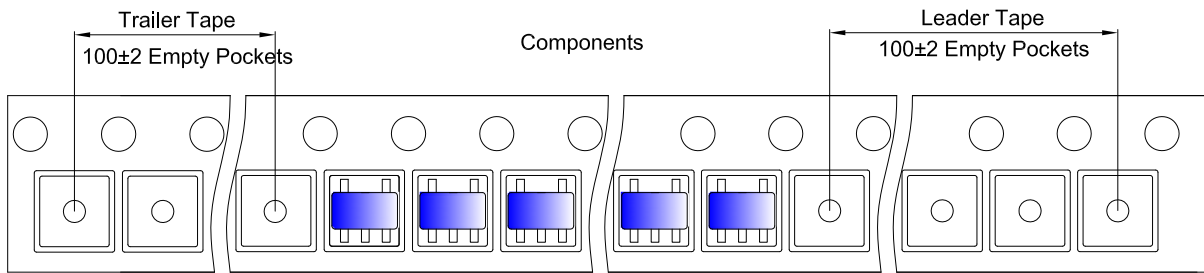

## TSOT-23-5L Reel

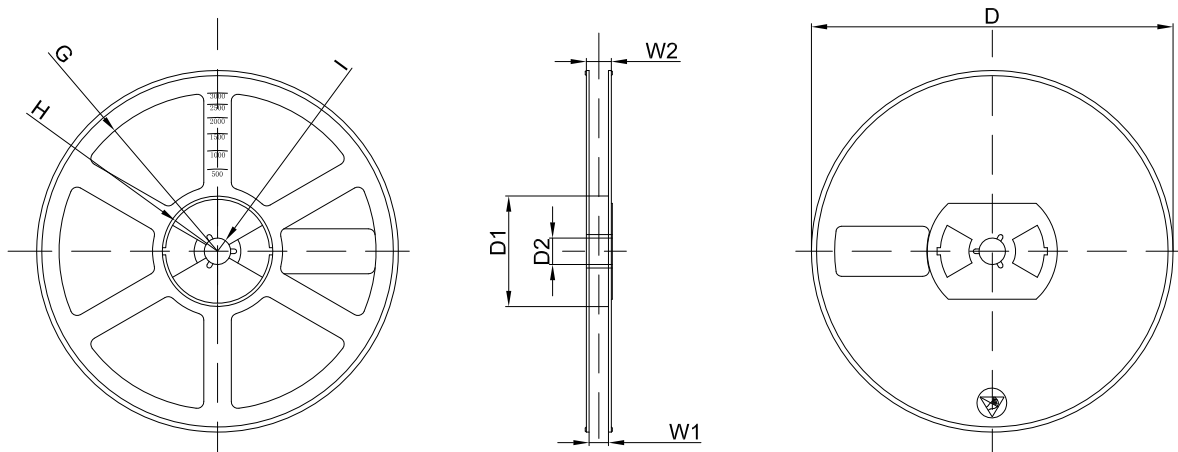

Dimensions are in millimeter								
Reel Option	D	D1	D2	G	H	I	W1	W2
7"Dia	Ø180.00	60.00	13.00	R78.00	R25.60	R6.50	9.50	13.10

REEL	Reel Size	Box	Box Size(mm)	Carton	Carton Size(mm)	G.W.(kg)
3000 pcs	7 inch	30,000 pcs	203×203×195	120,000 pcs	438×438×220	

## X-ON Electronics

Largest Supplier of Electrical and Electronic Components

*Click to view similar products for* [Diodes - General Purpose, Power, Switching category:](#)

*Click to view products by* [Changjing Electronics Technology manufacturer:](#)

Other Similar products are found below :

[MCL4151-TR3](#) [MMBD3004S-13-F](#) [RD0306T-H](#) [1N3611](#) [NTE156A](#) [NTE574](#) [NTE6244](#) [1SS193,LF](#) [1SS400CST2RA](#) [SDAA13](#)  
[SHN2D02FUTW1T1G](#) [LS4151GS08](#) [1N4449](#) [1N456A](#) [1N4934-E3/73](#) [1N914BTR](#) [RFUH20TB3S](#) [D291S45T](#) [BAV300-TR](#) [BAW56DWQ-](#)  
[7-F](#) [BAW56M3T5G](#) [BAW75-TAP](#) [MM230L-CAA](#) [IDW40E65D1](#) [JAN1N3600](#) [JAN1N4454UR-1](#) [LL4151-GS18](#) [SMMSD4148T3G](#)  
[BYW95B/A52A](#) [NSVDAN222T1G](#) [CDSZC01100-HF](#) [LL4150-M-08](#) [1N4454-TR](#) [BAV70HDW-7](#) [BAS28-7](#) [JANTX1N6640](#) [BAW56HDW-](#)  
[13](#) [BAS28 TR](#) [VS-HFA04SD60STR-M3](#) [NSVM1MA152WKT1G](#) [1SS388-TP](#) [RGP30D-E3/73](#) [VS-8EWF02S-M3](#) [BAV99TQ-13-F](#)  
[BAV99HDW-13](#) [MMDB30-E28X](#) [IDP20C65D2XKSA1](#) [LS4148](#) [IDV15E65D2](#) [NSVM1MA152WAT1G](#)