

## SOD-323 Plastic-Encapsulate Diodes

### BAT46WG SCHOTTKY BARRIER DIODE

#### FEATURES

- High breakdown voltage
- Low turn-on voltage
- Guard ring construction for transient protection

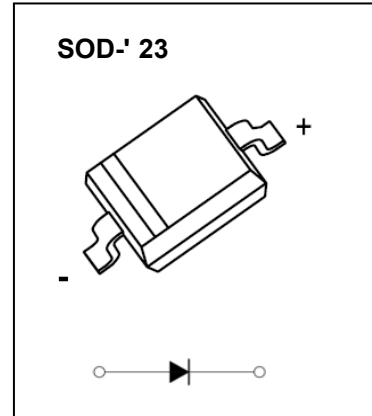

#### MARKING: S9

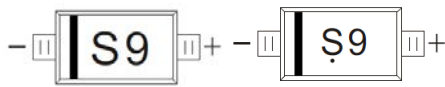

The marking bar indicates the cathode  
Solid dot = Green molding compound device, if none,  
the normal device.

#### Maximum Ratings @T<sub>a</sub>=25°C

Parameter	Symbol	Limit	Unit
Peak repetitive peak reverse voltage	V <sub>RRM</sub>	100	V
Working peak reverse voltage	V <sub>RWM</sub>		
Forward continuous current	I <sub>F</sub>	150	mA
Repetitive peak forward current (Note 1) @ t <sub>p</sub> < 1.0s, Duty Cycle < 50%	I <sub>FRM</sub>	350	mA
Non-repetitive Peak Forward surge current @ t = 8.3ms	I <sub>FSM</sub>	750	mA
Power dissipation	P <sub>D</sub>	200	mW
Thermal resistance junction to ambient air	R <sub>θJA</sub>	500	°C/W
Operating Junction Temperature Range	T <sub>J</sub>	-40 ~ +125	°C
Storage Temperature Range	T <sub>STG</sub>	-55 ~ +150	°C

#### ELECTRICAL CHARACTERISTICS (T<sub>a</sub>=25°C unless otherwise specified)

Parameter	Symbol	Test Conditions	Min	Typ	Max	Unit
Reverse breakdown voltage(Note 2)	V <sub>R</sub>	I <sub>R</sub> = 100μA	100			V
Reverse voltage leakage current	I <sub>R</sub>	V <sub>R1</sub> =1.5V			0.3	μA
		V <sub>R2</sub> =10V			0.5	
		V <sub>R3</sub> =50V			1	
		V <sub>R4</sub> =75V			2	
Forward voltage(Note 2)	V <sub>F</sub>	I <sub>F1</sub> =0.1mA			0.25	V
		I <sub>F2</sub> =10mA			0.45	
		I <sub>F3</sub> =250mA			1	
Diode capacitance	C <sub>T</sub>	V <sub>R</sub> =0, f=1MHz		20		pF
		V <sub>R</sub> =1V, f=1MHz		12		

Notes: 1. Part mounted on FR-4 board with recommended pad layout.

2. Short duration pulse test used to minimize self-heating effect.

# Typical Characteristics

### Forward Characteristics

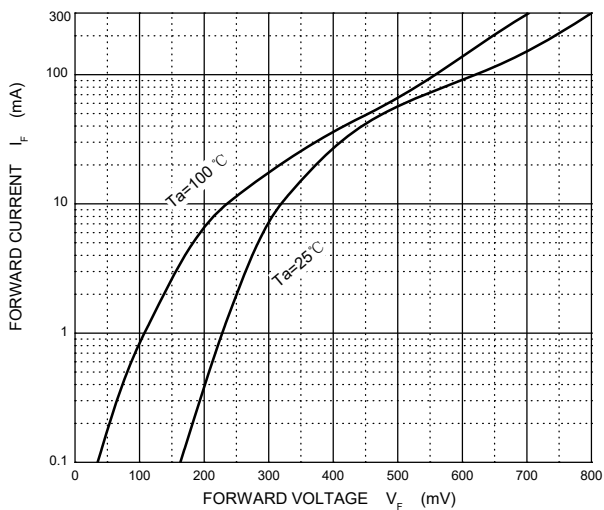

### Reverse Characteristics

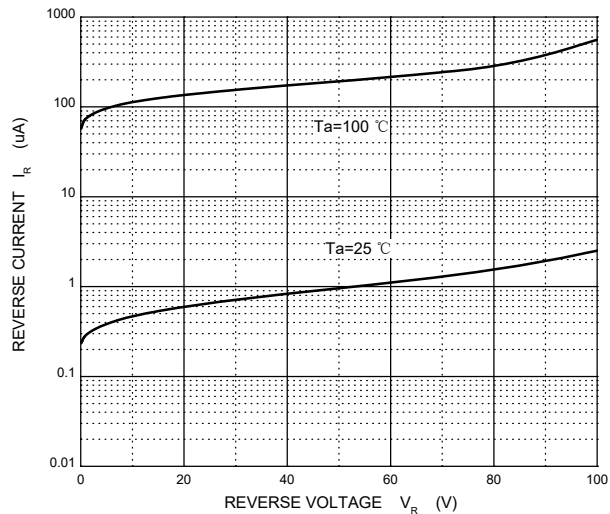

### Capacitance Characteristics

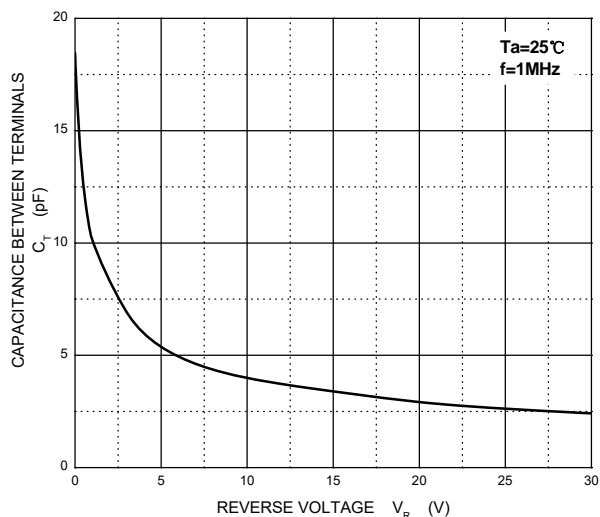

### Power Derating Curve

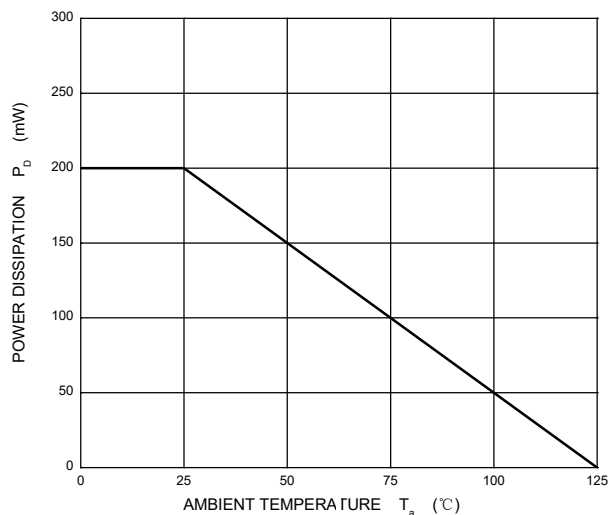

SOD-323 Package Outline Dimensions

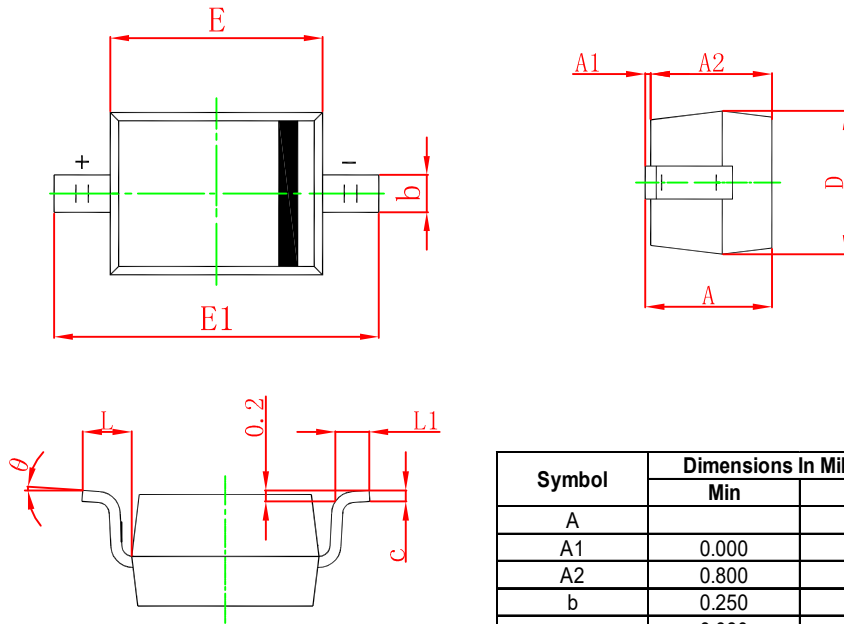

Symbol	Dimensions In Millimeters		Dimensions In Inches	
	Min	Max	Min	Max
A		1.100		0.043
A1	0.000	0.100	0.000	0.004
A2	0.800	1.000	0.031	0.039
b	0.250	0.350	0.010	0.014
c	0.080	0.150	0.003	0.006
D	1.200	1.400	0.047	0.055
E	1.600	1.800	0.063	0.071
E1	2.500	2.750	0.098	0.108
L	0.475 REF		0.019 REF	
L1	0.250	0.400	0.010	0.016
θ	0°		8°	

SOD-323 Suggested Pad Layout

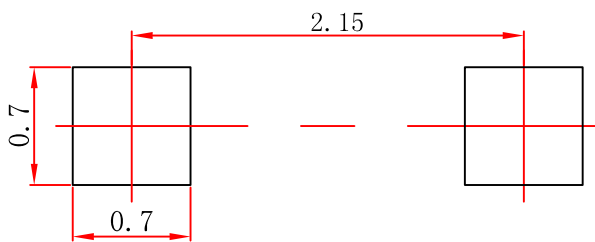

- Note:**
1. Controlling dimension: in millimeters.
  2. General tolerance: ± 0.05mm.
  3. The pad layout is for reference purposes only.

**NOTICE**

JSCJ reserves the right to make modifications, enhancements, improvements, corrections or other changes without further notice to any product herein. JSCJ does not assume any liability arising out of the application or use of any product described herein.

# SOD-323 Tape and Reel

## SOD-323 Embossed Carrier Tape

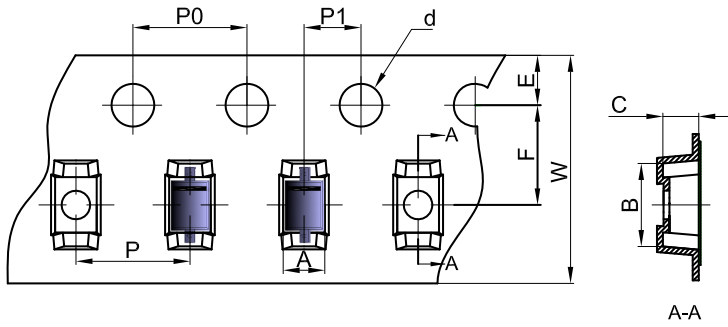

**Packaging Description:**  
 SOD-323 parts are shipped in tape. The carrier tape is made from a dissipative (carbon filled) polycarbonate resin. The cover tape is a multilayer film (Heat Activated Adhesive in nature) primarily composed of polyester film, adhesive layer, sealant, and anti-static sprayed agent. These reeled parts in standard option are shipped with 3,000 units per 7" or 17.8cm diameter reel. The reels are clear in color and is made of polystyrene plastic (anti-static coated).

Dimensions are in millimeter										
Pkg type	A	B	C	d	E	F	P0	P	P1	W
SOD-323	1.48	3.3	1.25	Ø1.50	1.75	3.50	4.00	4.00	2.00	8.00

## SOD-323 Tape Leader and Trailer

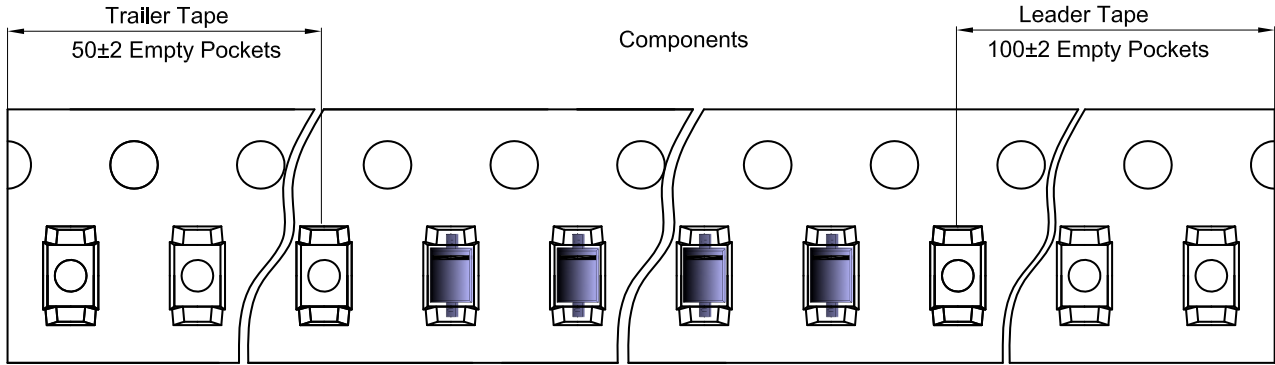

## SOD-323 Reel

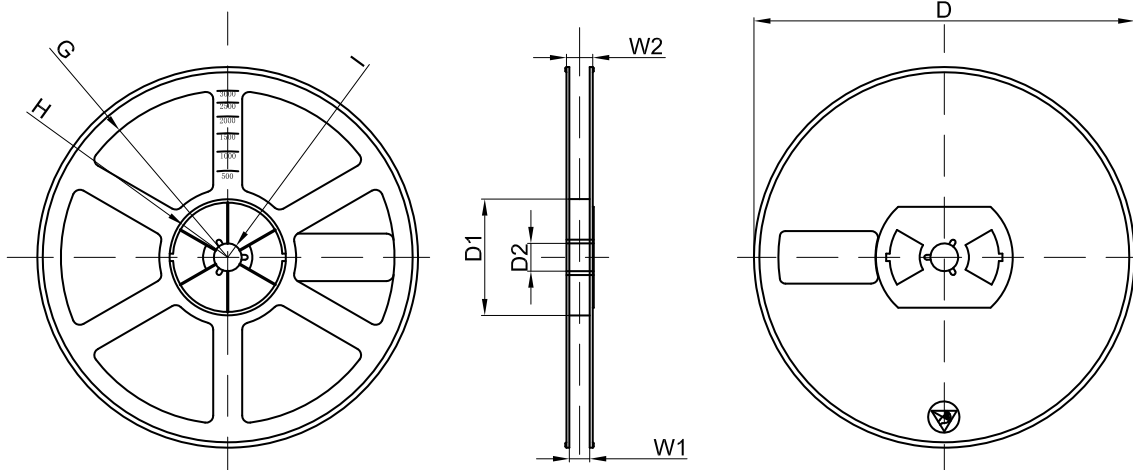

Dimensions are in millimeter								
Reel Option	D	D1	D2	G	H	I	W1	W2
7"Dia	Ø178.00	54.40	13.00	R78.00	R25.60	R6.50	9.50	12.30

REEL	Reel Size	Box	Box Size(mm)	Carton	Carton Size(mm)	G.W.(kg)
3000 pcs	7 inch	45,000 pcs	203×203×195	180,000 pcs	438×438×220	

# Attention

This device is only suitable for circuit protection with properly reverse biased below its peak reverse voltage.

JSCJ will not take any responsibilities from risks arisen by applying reverse voltage that is higher than its rated peak reverse voltage, which will keep the device reverse conducting constantly and might cause thermal failure.

JSCJ reserves all rights of interpretation.

## X-ON Electronics

Largest Supplier of Electrical and Electronic Components

*Click to view similar products for [Schottky Diodes & Rectifiers](#) category:*

*Click to view products by [Changjing Electronics Technology](#) manufacturer:*

Other Similar products are found below :

[MA4E2508M-1112](#) [MBR0530L-TP](#) [MBR10100CT-BP](#) [MBR1545CT](#) [MMBD301M3T5G](#) [RB160M-50TR](#) [BAS16E6433HTMA1](#) [BAS3010S-02LRH E6327](#) [BAT 54-02LRH E6327](#) [IDL02G65C5XUMA1](#) [NSR05F40QNXT5G](#) [NTE555](#) [JANS1N6640](#) [SB07-03C-TB-H](#) [SBS818-TL-E](#) [SK310-T](#) [SK34B-TP](#) [SS3003CH-TL-E](#) [PDS3100Q-7](#) [GA01SHT18](#) [CRS10I30A\(TE85L,QM](#) [MA4E2501L-1290](#) [MBRB30H30CT-1G](#) [JANTX1N5712-1](#) [SB007-03C-TB-E](#) [SK33B-TP](#) [SK35A-TP](#) [SK38B-LTP](#) [NTE505](#) [NTSB30U100CT-1G](#) [VS-6CWQ10FNHM3](#) [CRG04\(T5L,TEMQ\)](#) [ACDBA1100LR-HF](#) [ACDBA1200-HF](#) [ACDBA240-HF](#) [ACDBA3100-HF](#) [CDBQC0530L-HF](#) [ACDBA260LR-HF](#) [ACDBA1100-HF](#) [MA4E2502L-1246](#) [10BQ015-M3/5BT](#) [NRVB130LSFT1G](#) [CRS08TE85LQM](#) [PMAD1108-LF](#) [B120Q-13-F](#) [1N5819T-G](#) [B0530WSQ-7-F](#) [PDS1040Q-13](#) [B160BQ-13-F](#) [B140S1F-7](#)