

## CJ6335 Series

### ■ INTRODUCTION

The CJ6335 series, implemented in CMOS technology, is a set of three-terminal, high load current and low voltage regulator. CJ6335 series offer 100mA output current and allow an input voltage as high as 18V. They are available with several fixed output voltages ranging from 1.2V to 5.0V. CMOS technology ensures low voltage drop and low quiescent current.

### ■ APPLICATIONS

- Battery-Powered Equipments
- Wireless Communication Equipments
- Portable Audio Video Equipments

### ■ FEATURES

- Low Quiescent Current: 2.5uA(Typ)
- Max Operating Voltage: 18V
- Output Current: 100mA
- Low Dropout Voltage: 100mV@1mA
- Output Voltage: 1.2~ 5.0V

### ■ BLOCK DIAGRAM

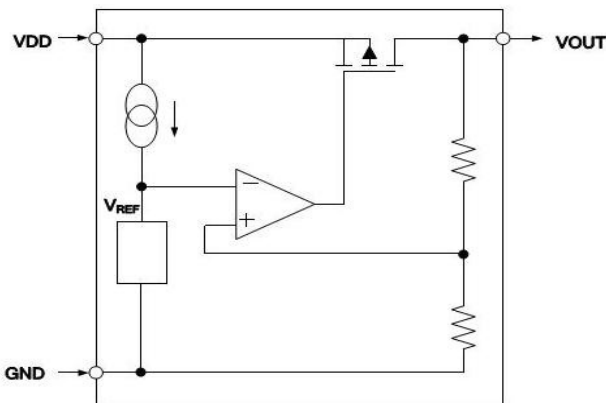

### ■ ORDER INFORMATION

#### CJ6335①②③④

DESIGNATOR	SYMBOL	DESCRIPTION
①	A	Standard
②③	Integer	Output Voltage e.g. 1.8V=②:1, ③:8
④	N	Package:SOT-23
	M	Package:SOT-23-3L
	MR	Package:SOT-23-5L
	P	Package:SOT-89-3L

# Pin Configuration

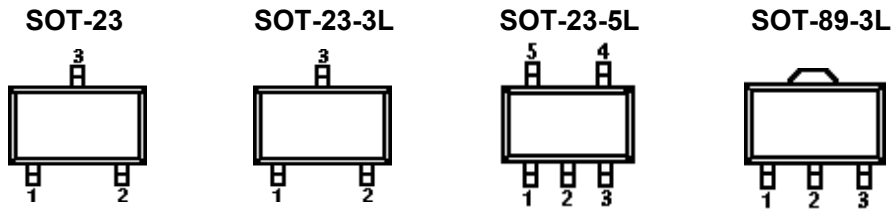

PIN NUMBER			PIN NAME	FUNCTION
SOT-23	SOT-23-3L	SOT-89-3L		
N	M	P		
1	1	1	$V_{SS}$	Ground
2	2	3	$V_{OUT}$	Output
3	3	2	$V_{IN}$	Power input

PIN NUMBER	PIN NAME	FUNCTION
SOT-23-5L		
MR		
1	$V_{SS}$	Power Input
2	$V_{IN}$	Ground
3	$V_{OUT}$	Output
4/5	NC	No Connection

## Electrical Characteristics

### ■ ABSOLUTE MAXIMUM RATINGS<sup>(1)</sup>

(Unless otherwise specified,  $T_A=25^\circ\text{C}$ )

PARAMETER		SYMBOL	RATINGS	UNITS
Input Voltage <sup>(2)</sup>		$V_{IN}$	-0.3~20	V
Output Voltage <sup>(2)</sup>		$V_{OUT}$	-0.3~7	V
CE Pin Voltage		$V_{CE}$	-0.3~ $V_{in}+0.3$	V
Output Current		$I_{OUT}$	100	mA
Power Dissipation	SOT-23	$P_D$	0.25	W
	SOT-23-3L/5L		0.3	W
	SOT-89-3L		0.5	W
Operating Ambient Temperature Range <sup>(3)</sup>		$T_a$	-25~85	$^\circ\text{C}$
Storage Temperature		$T_{stg}$	-40~125	$^\circ\text{C}$
Lead Temperature(Soldering, 10 sec)		$T_{solder}$	260	$^\circ\text{C}$
ESD Rating	Human Body Model (HBM)		4	kV
	Machine Model (MM)		400	V

(1) Stresses beyond those listed under *absolute maximum ratings* may cause permanent damage to the device. These are stress ratings only, and functional operation of the device at these or any other conditions beyond those indicated under *recommended operating conditions* is not implied. Exposure to absolute-maximum-rated conditions for extended periods may affect device reliability.

(2) All voltage values are with respect to network ground terminal.

(3) The CJ6335 includes over temperature protection that is intended to protect the device during momentary overload. Junction temperature will exceed  $125^\circ\text{C}$  when over temperature protection is active. Continuous operation above the specified maximum operating junction temperature may impair device reliability.

### ■ ELECTRICAL CHARACTERISTICS

( $V_{IN}=V_{OUT}+1\text{V}$ ,  $C_{IN}=1\sim 10\mu\text{F}$ ,  $C_{OUT}=1\sim 10\mu\text{F}$ ,  $T_A=25^\circ\text{C}$ , unless otherwise specified)

PARAMETER	SYMBOL	CONDITIONS	MIN.	TYP. <sup>(4)</sup>	MAX.	UNITS
Input Voltage	$V_{IN}$		-0.3	—	18	V
Output Voltage	$V_{OUT(E)}^{(5)}$	$I_{OUT}=1\text{mA}$	$V_{OUT}^{(6)}$ *0.98	$V_{OUT}^{(6)}$	$V_{OUT}^{(6)}$ *1.02	V
Dropout Voltage	$V_{DO}^{(7)}$	$I_{OUT}=1\text{mA}$	—	100	—	mV
Output Current	$I_{OUT}$	$V_{IN}=V_{OUT}+1\text{V}$	100	—	—	mA
Supply Current	$I_{SS}$	$I_{OUT}=0\text{A}$	—	2.5	3.5	$\mu\text{A}$
Line Regulation	$\frac{\Delta V_{OUT}}{V_{OUT} \times \Delta V_{IN}}$	$I_{OUT}=1\text{mA}$ $V_{OUT}+2\text{V} \leq V_{IN} \leq 18\text{V}$	—	0.2	-	%/V
Load Regulation	$\Delta V_{OUT}$	$V_{IN}=V_{OUT}+2\text{V}$ , $1\text{mA} \leq I_{OUT} \leq 70\text{mA}$	—	60	150	mV
Temperature Coefficient	$\frac{\Delta V_{OUT}}{\Delta T_A}$	$V_{DD}=V_{OUT}+2\text{V}$ , $I_{OUT}=10\text{mA}$ $0^\circ\text{C} < T_A < 70^\circ\text{C}$		$\pm 0.75$		mV/ $^\circ\text{C}$

(4) Typical numbers are at  $25^\circ\text{C}$  and represent the most likely norm.

(5)  $V_{OUT(E)}$  : Effective Output Voltage (I.e. The output voltage when  $V_{IN} = (V_{OUT} + 1.0\text{V})$ , And Maintain A Certain  $I_{OUT}$  Value).

(6)  $V_{OUT}$ : Specified Output Voltage.

(7)  $V_{DO}$  : The Difference Of Output Voltage And Input Voltage When Input Voltage Is Decreased Gradually Till Output Voltage Equals To 98% Of  $V_{OUT(E)}$ .

---

## Typical Application

---

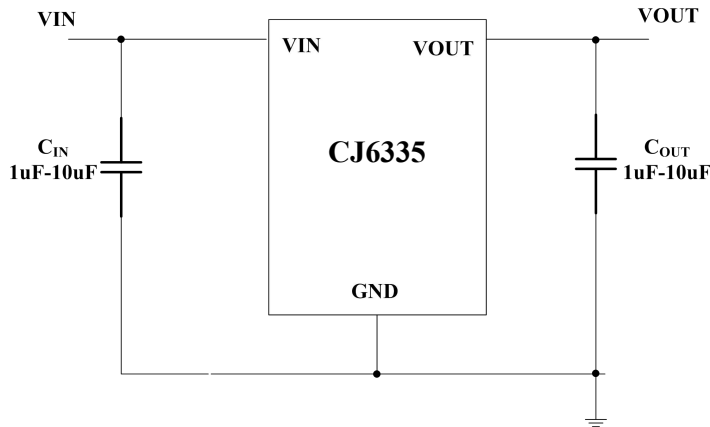

### ■ APPLICATION INFORMATION

#### Selection of Input/ Output Capacitors

In general, all the capacitors need to be low leakage. Any leakage the capacitors have will reduce efficiency, increase the quiescent current.

A recent trend in the design of portable devices has been to use ceramic capacitors to filter DC-DC converter inputs. Ceramic capacitors are often chosen because of their small size, low equivalent series resistance (ESR) and high RMS current capability. Also, recently, designers have been looking to ceramic capacitors due to shortages of tantalum capacitors.

Unfortunately, using ceramic capacitors for input filtering can cause problems. Applying a voltage step to a ceramic capacitor causes a large current surge that stores energy in the inductances of the power leads. A large voltage spike is created when the stored energy is transferred from these inductances into the ceramic capacitor. These voltage spikes can easily be twice the amplitude of the input voltage step.

Many types of capacitors can be used for input bypassing, however, caution must be exercised when using multilayer ceramic capacitors (MLCC). Because of the self-resonant and high Q characteristics of some types of ceramic capacitors, high voltage transients can be generated under some start-up conditions, such as connecting the LDO input to a live power source.

The LDO also requires an output capacitor for loop stability. Connect a  $1\mu\text{F}\sim 10\mu\text{F}$  tantalum capacitor from OUT to GND close to the pins. For improved transient response, this output capacitor may be ceramic.

## Typical Characteristics

( $C_{IN}=C_{OUT}=1\mu F/X7R$ ,  $V_{OUT}=3.3V$ , unless otherwise specified)

### Output Voltage vs. Output Current

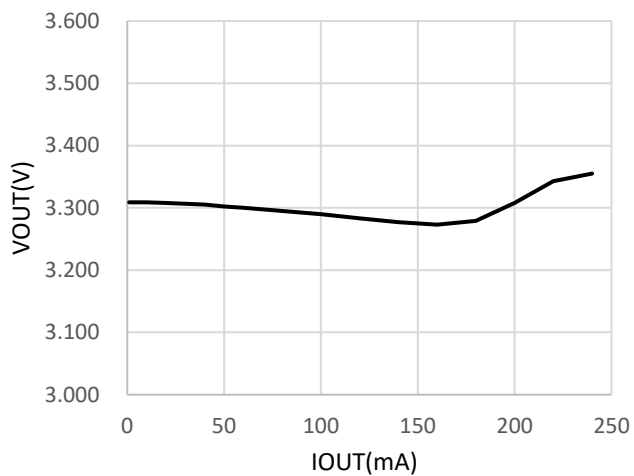

### Output Voltage vs. Input Voltage

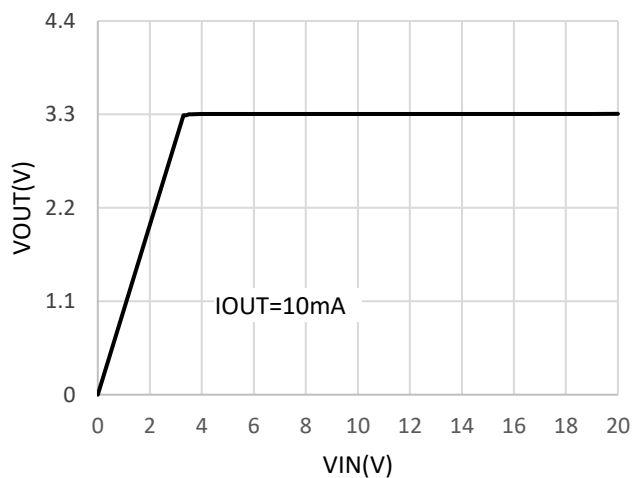

### Quiescent Current vs. Input Voltage

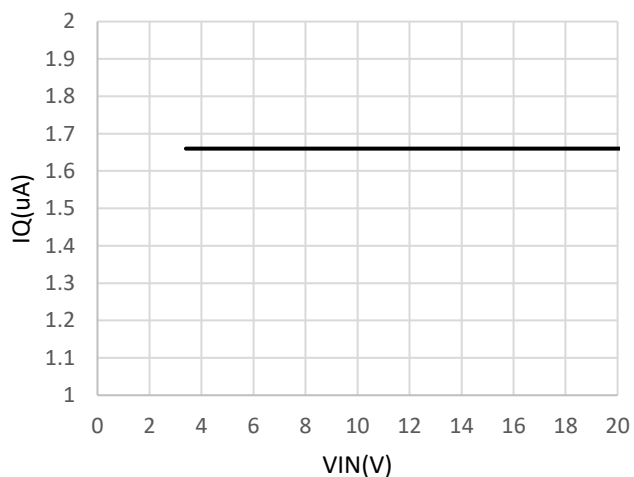

### Dropout Voltage vs. Output Current

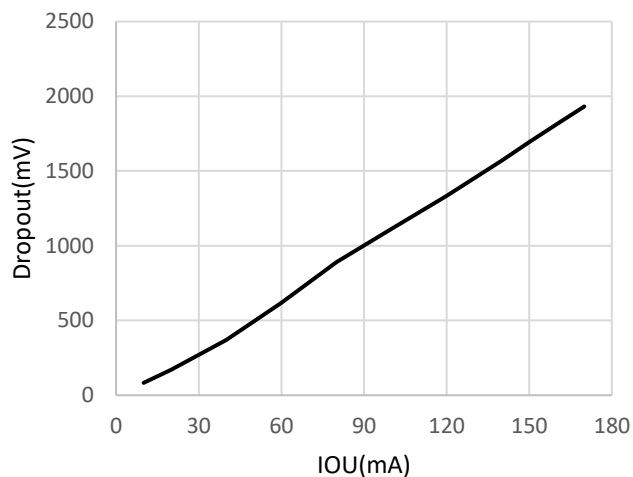

## SOT-23 Package Outline Dimensions

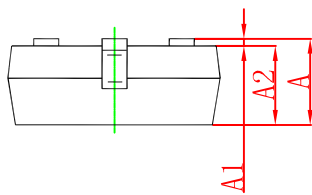
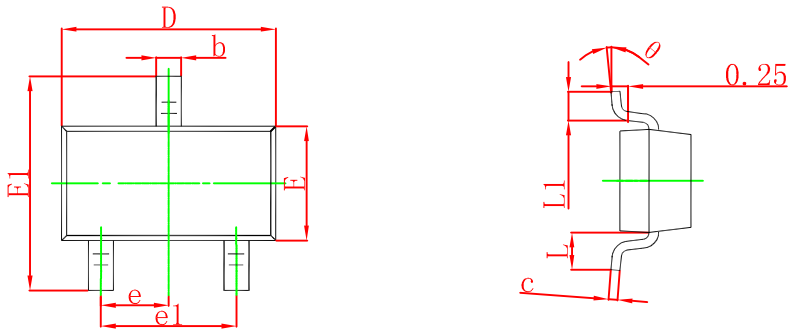

Symbol	Dimensions In Millimeters		Dimensions In Inches	
	Min	Max	Min	Max
A	0.900	1.150	0.035	0.045
A1	0.000	0.100	0.000	0.004
A2	0.900	1.050	0.035	0.041
b	0.300	0.500	0.012	0.020
c	0.080	0.150	0.003	0.006
D	2.800	3.000	0.110	0.118
E	1.200	1.400	0.047	0.055
E1	2.250	2.550	0.089	0.100
e	0.950 TYP		0.037 TYP	
e1	1.800	2.000	0.071	0.079
L	0.550 REF		0.022 REF	
L1	0.300	0.500	0.012	0.020
θ	0°	8°	0°	8°

## SOT-23 Suggested Pad Layout

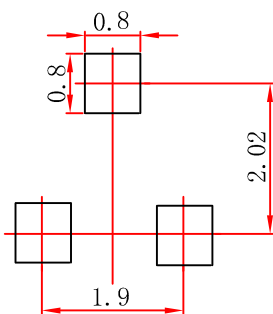

**Note:**

1. Controlling dimension: in millimeters.
2. General tolerance:  $\pm 0.05$ mm.
3. The pad layout is for reference purposes only.

## SOT-23-3L Package Outline Dimensions

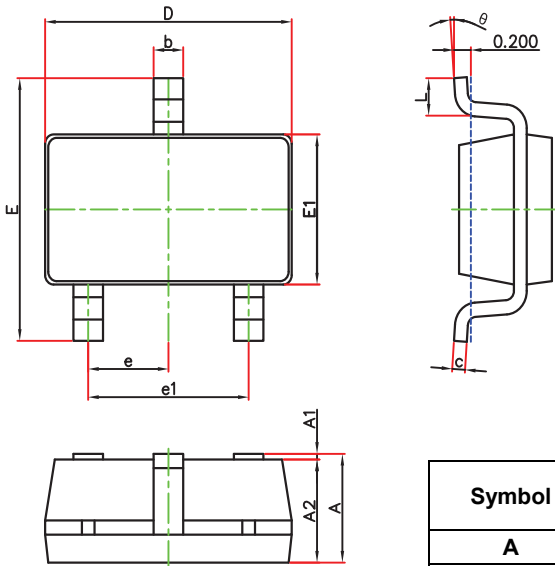

Symbol	Dimensions In Millimeters		Dimensions In Inches	
	Min.	Max.	Min.	Max.
A	1.050	1.250	0.041	0.049
A1	0.000	0.100	0.000	0.004
A2	1.050	1.150	0.041	0.045
b	0.300	0.500	0.012	0.020
c	0.100	0.200	0.004	0.008
D	2.820	3.020	0.111	0.119
E	2.650	2.950	0.104	0.116
E1	1.500	1.700	0.059	0.067
e	0.950(BSC)		0.037(BSC)	
e1	1.800	2.000	0.071	0.079
L	0.300	0.600	0.012	0.024
θ	0°	8°	0°	8°

## SOT-23-3L Suggested Pad Layout

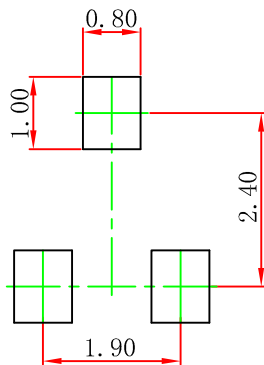

- Note:
1. Controlling dimension: in millimeters.
  2. General tolerance:  $\pm 0.05\text{mm}$ .
  3. The pad layout is for reference purposes only.

## SOT-23-5L Package Outline Dimensions

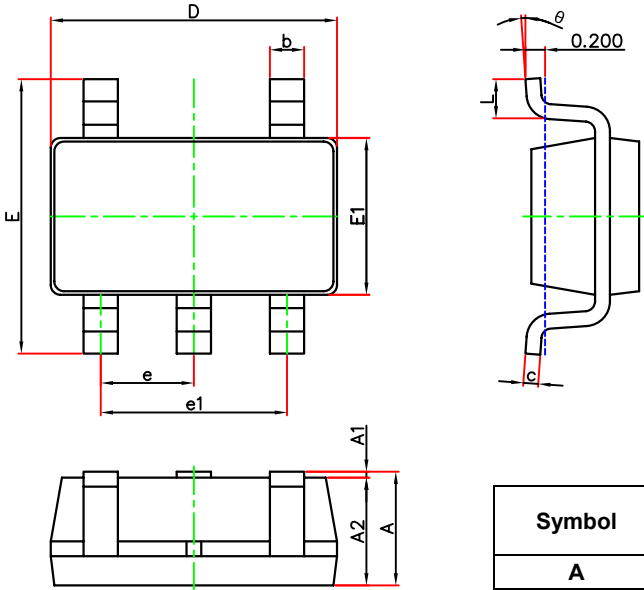

Symbol	Dimensions In Millimeters		Dimensions In Inches	
	Min.	Max.	Min.	Max.
A	1.050	1.250	0.041	0.049
A1	0.000	0.100	0.000	0.004
A2	1.050	1.150	0.041	0.045
b	0.300	0.500	0.012	0.020
c	0.100	0.200	0.004	0.008
D	2.820	3.020	0.111	0.119
E	2.650	2.950	0.104	0.116
E1	1.500	1.700	0.059	0.067
e	0.950(BSC)		0.037(BSC)	
e1	1.800	2.000	0.071	0.079
L	0.300	0.600	0.012	0.024
$\theta$	0°	8°	0°	8°

## SOT-23-5L Suggested Pad Layout

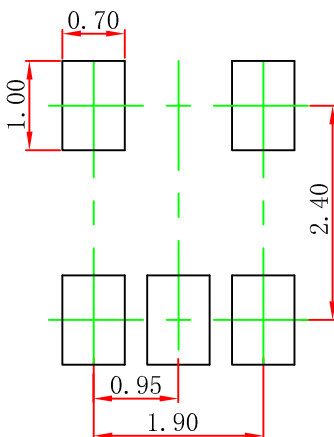

Note:

1. Controlling dimension: in millimeters.
2. General tolerance:  $\pm 0.05\text{mm}$ .
3. The pad layout is for reference purposes only.



## SOT-89-3L Package Outline Dimensions

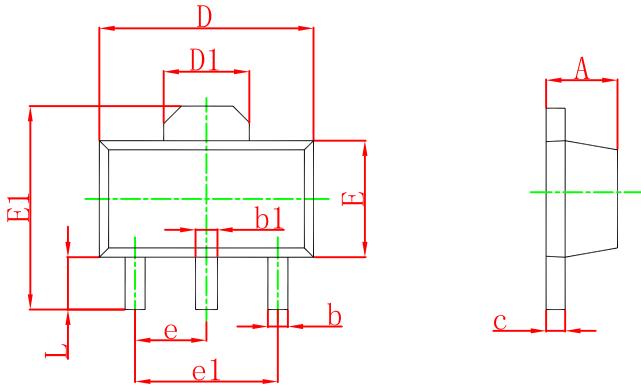

Symbol	Dimensions In Millimeters		Dimensions In Inches	
	Min.	Max.	Min.	Max.
A	1.400	1.600	0.055	0.063
b	0.320	0.520	0.013	0.197
b1	0.400	0.580	0.016	0.023
c	0.350	0.440	0.014	0.017
D	4.400	4.600	0.173	0.181
D1	1.550 REF		0.061 REF	
E	2.300	2.600	0.091	0.102
E1	3.940	4.250	0.155	0.167
e	1.500 TYP		0.060 TYP	
e1	3.000 TYP		0.118 TYP	
L	0.900	1.200	0.035	0.047

## SOT-89-3L Suggested Pad Layout

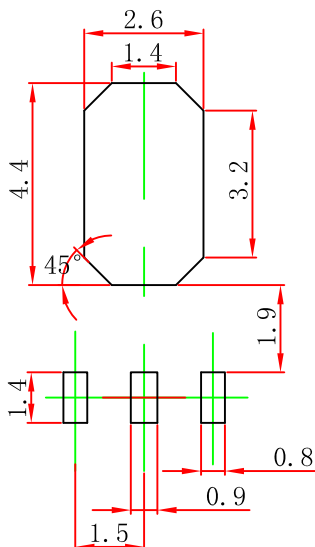

- Note:
1. Controlling dimension: in millimeters.
  2. General tolerance:  $\pm 0.05\text{mm}$ .
  3. The pad layout is for reference purposes only.

# DISCLAIMER

## **IMPORTANT NOTICE, PLEASE READ CAREFULLY**

The information in this data sheet is intended to describe the operation and characteristics of our products. JSCJ has the right to make any modification, enhancement, improvement, correction or other changes to any content in this data sheet, including but not limited to specification parameters, circuit design and application information, without prior notice.

Any person who purchases or uses JSCJ products for design shall: 1. Select products suitable for circuit application and design; 2. Design, verify and test the rationality of circuit design; 3. Procedures to ensure that the design complies with relevant laws and regulations and the requirements of such laws and regulations. JSCJ makes no warranty or representation as to the accuracy or completeness of the information contained in this data sheet and assumes no responsibility for the application or use of any of the products described in this data sheet.

Without the written consent of JSCJ, this product shall not be used in occasions requiring high quality or high reliability, including but not limited to the following occasions: medical equipment, automotive electronics, military facilities and aerospace. JSCJ shall not be responsible for casualties or property losses caused by abnormal use or application of this product.

Official Website: [www.jscj-elec.com](http://www.jscj-elec.com)

Copyright © JIANGSU CHANGJING ELECTRONICS TECHNOLOGY CO., LTD.

## X-ON Electronics

Largest Supplier of Electrical and Electronic Components

*Click to view similar products for [Linear Voltage Regulators](#) category:*

*Click to view products by [Changjing Electronics Technology](#) manufacturer:*

Other Similar products are found below :

[LV5684PVD-XH](#) [MCDTSA6-2R](#) [L7815ACV-DG](#) [714954EB](#) [ZMR500QFTA](#) [BA033LBSG2-TR](#) [LV5680P-E](#) [L79M05T-E](#) [L78LR05D-MA-E](#) [NCV317MBTG](#) [NTE7227](#) [MP2018GZD-33-P](#) [MP2018GZD-5-P](#) [LV5680NPVC-XH](#) [LT1054CN8](#) [UA78L09CLP](#) [UA78L09CLPR](#) [CAT6221-PPTD-GT3](#) [MC78M09CDTRK](#) [NCV51190MNTAG](#) [78M05](#) [HT7150-1](#) [UM1540DB-18](#) [XC6234H281VR-G](#) [WL2834CA-6/TR](#) [TPL730F33-5TR](#) [TLS850F1TA](#) [V50](#) [TPS549B22RVFR](#) [UM1540DB-33](#) [WL9200P3-50B](#) [WL9100P3-33B](#) [WL9005D4-33](#) [XC6219B152MR](#) [WL2855K33-3/TR](#) [PJ54BM33SE](#) [PJ9500M25SA](#) [MD7218E33PC1](#) [H7533-2PR](#) [SK7812AU](#) [SD1A30](#) [78L33](#) [TP78L33T3](#) [L78L33ACUTR](#) [SK6513ST3A-50](#) [SK6054D4-09](#) [SK6054D4-18](#) [SK6054D4-11](#) [SK6054D4-10](#) [LM79L12F](#) [HLP2985AIM5X-5.0](#)