

## CJ6376 Series

### ■ INTRODUCTION

The CJ6376 Series are a group of positive voltage regulators manufactured by CMOS technologies with low power consumption and low dropout voltage, which provide large output currents even when the difference of the input-out-put voltage is small.

The CJ6376 Series can deliver 300 mA output current and allow an input voltage as high as 28V. The series are very suitable for the battery powered equipments, such as RF applications and other systems requiring a quiet voltage source.

### ■ APPLICATIONS

- Cordless Phones
- Radio control systems
- Laptop, Palmtops and PDAs
- Single-lens reflex DSC
- PC peripherals with memory
- LAN Cards
- Ultra Low Power Microcontrollers

### ■ BLOCK DIAGRAM

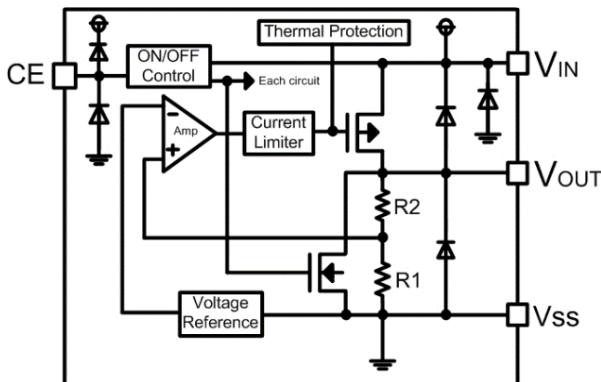

- Wireless Communication Equipments
- Portable Audio Video Equipments
- Car Navigation Systems

### ■ FEATURES

- Low Quiescent Current: 2 $\mu$ A
- Operating Voltage Range: 2.5V~36V
- Output Current: 300mA
- Low Dropout Voltage:  
200mV@100mA( $V_{OUT}=3.3V$ )
- Output Voltage: 1.2~12V
- High Accuracy:  $\pm 2\%/\pm 1\%$ (Typ.)
- High Power Supply Rejection Ratio:  
70dB@1kHz
- Low Output Noise:  
27x $V_{OUT}$   $\mu$ V<sub>RMS</sub>(10Hz~100kHz)
- Excellent Line and Load Transient Response
- Built-in Current Limiter, Short-Circuit Protection
- Over-Temperature Protection

### ■ ORDER INFORMATION

#### CJ6376①②③④

DESIGNATOR	SYMBOL	DESCRIPTION
①	A	Standard
	B	High Active, pull-down resistor built-in, with $C_{OUT}$ discharge resistor
②③	Integer	Output Voltage e.g.3.3V=②:3, ③:3
④	M/MC/MY	Package:SOT-23-3L
	M/MR/MF	Package:SOT-23-5L
	G/GW/GL	Package:SOT-223

# Pin Configuration

SOT-23-3L

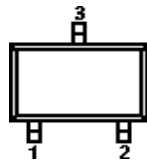

SOT-23-5L

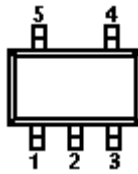

SOT-223

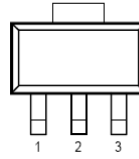

SOT-23-3L

PIN NUMBER			PIN NAME	FUNCTION
CJ6376AxxM/MC/MY				
M	MC	MY		
1	3	3	$V_{SS}$	Ground
2	2	1	$V_{OUT}$	Output
3	1	2	$V_{IN}$	Power Input

SOT-23-5L

PIN NUMBER			PIN NAME	FUNCTION
CJ6376BxxM	CJ6376AxxMF/MR			
M	MF	MR		
1	1	2	$V_{IN}$	Power Input
2	2	1	$V_{SS}$	Ground
3	/	/	CE	Chip Enable Pin
4	3/4	4/5	NC	No Connection
5	5	3	$V_{OUT}$	Output

SOT-223

PIN NUMBER			PIN NAME	FUNCTION
CJ6376AxxG/GW/GL				
G	GW	GL		
1	1	2	$V_{IN}$	Power input
2	3	1	$V_{SS}$	Ground
3	2	3	$V_{OUT}$	Output

## Electrical Characteristics

### ■ ABSOLUTE MAXIMUM RATINGS<sup>(1)</sup>

(Unless otherwise specified,  $T_A=25^{\circ}\text{C}$ )

PARAMETER		SYMBOL	RATINGS	UNITS
Input Voltage <sup>(2)</sup>		$V_{IN}$	-0.3~40	V
Output Voltage <sup>(2)</sup>		$V_{OUT}$	-0.3~13	V
CE Pin Voltage		$V_{CE}$	-0.3~33	V
Output Current		$I_{OUT}$	600	mA
Power Dissipation	SOT-23-3L	$P_D$	0.3	W
	SOT-23-5L		0.5	W
	SOT-223		0.8	W
Operating Ambient Temperature Range		$T_A$	-40~85	$^{\circ}\text{C}$
Operating Junction Temperature Range <sup>(3)</sup>		$T_j$	-40~125	$^{\circ}\text{C}$
Storage Temperature		$T_{stg}$	-40~125	$^{\circ}\text{C}$
Lead Temperature(Soldering, 10 sec)		$T_{solder}$	260	$^{\circ}\text{C}$

(1) Stresses beyond those listed under *absolute maximum ratings* may cause permanent damage to the device. These are stress ratings only, and functional operation of the device at these or any other conditions beyond those indicated under *recommended operating conditions* is not implied. Exposure to absolute-maximum-rated conditions for extended periods may affect device reliability.

(2) All voltages are with respect to network ground terminal.

(3) This IC includes over temperature protection that is intended to protect the device during momentary overload. Junction temperature will exceed  $125^{\circ}\text{C}$  when over temperature protection is active. Continuous operation above the specified maximum operating junction temperature may impair device reliability.

### ■ RECOMMENDED OPERATING CONDITIONS

PARAMETER	MIN.	NOM.	MAX.	UNITS
Supply voltage at $V_{IN}$	2.5		36	V
Operating junction temperature range, $T_j$	-40		125	$^{\circ}\text{C}$
Operating free air temperature range, $T_A$	-40		85	$^{\circ}\text{C}$

## Electrical Characteristics

**CJ6376 Series** ( $V_{IN}=V_{OUT}+1V, C_{IN}=C_{OUT}=1\mu F, T_A=25^\circ C$ , unless otherwise specified)

PARAMETER	SYMBOL	CONDITIONS	MIN.	TYP. <sup>(4)</sup>	MAX.	UNITS	
Input Voltage	$V_{IN}$		2.5	—	36	V	
Output Voltage Range	$V_{OUT}$		2.1	—	12	V	
DC Output Accuracy		$I_{OUT}=10mA$	-2	—	2	%	
			-1	—	1	%	
Dropout Voltage	$V_{dif}^{(5)}$	$I_{OUT}=100mA, V_{OUT}=3.3V$	—	200	—	mV	
Supply Current	$I_{SS}$	$I_{OUT}=0A$	$1.2V < V_{OUT} \leq 7.0V$	—	2	5	$\mu A$
			$7.0V < V_{OUT} \leq 12V$	—	3	6	$\mu A$
Line Regulation	$\frac{\Delta V_{OUT}}{V_{OUT} \times \Delta V_{IN}}$	$I_{OUT}=10mA$ $V_{OUT}+1V \leq V_{IN} \leq 36V$	—	0.01	0.3	%/V	
Load Regulation	$\Delta V_{OUT}$	$V_{IN}=V_{OUT}+1V,$ $1mA \leq I_{OUT} \leq 100mA$	—	10	—	mV	
Temperature Coefficient	$\frac{\Delta V_{OUT}}{V_{OUT} \times \Delta T_A}$	$I_{OUT}=40mA,$ $-40^\circ C < T_A < 85^\circ C$	—	50	—	ppm	
Output Current Limit	$I_{LIM}$	$V_{OUT}=0.5 \times V_{OUT(Normal)},$ $V_{IN}=5V$	350	600	—	mA	
Short Current	$I_{SHORT}$	$V_{OUT}=V_{SS}$	—	100	—	mA	
Power Supply Rejection Ratio	PSRR	$I_{OUT}=50mA$	100Hz	—	75	—	dB
			1kHz	—	70	—	
			10kHz	—	55	—	
			100kHz	—	40	—	
Output Noise Voltage	$V_{ON}$	BW=10Hz to 100kHz	—	$27 \times V_{OUT}$	—	$\mu V_{RMS}$	
Thermal Shutdown Temperature	$T_{SD}$	—	—	160	—	$^\circ C$	
Thermal Shutdown Hysteresis	$\Delta T_{SD}$	—	—	20	—	$^\circ C$	
Standby Current	$I_{STBY}$	$CE = V_{SS}$	—	—	0.5	$\mu A$	
CE "High" Voltage	$V_{CE} "H"$		1.5	—	$V_{IN}$	V	
CE "Low" Voltage	$V_{CE} "L"$		—	—	0.3	V	
$C_{OUT}$ Auto-Discharge Resistance	$I_{SHORT}$	$V_{IN}=5V, V_{OUT}=3.0V,$ $V_{CE}=V_{SS}$	—	150	—	$\Omega$	

(4) Typical numbers are at 25°C and represent the most likely norm.

(5) $V_{dif}$ : The Difference Of Output Voltage And Input Voltage When Input Voltage Is Decreased Gradually Till Output Voltage Equals To 98% Of  $V_{OUT}$  (E).

### ■ TYPICAL APPLICATION CIRCUIT

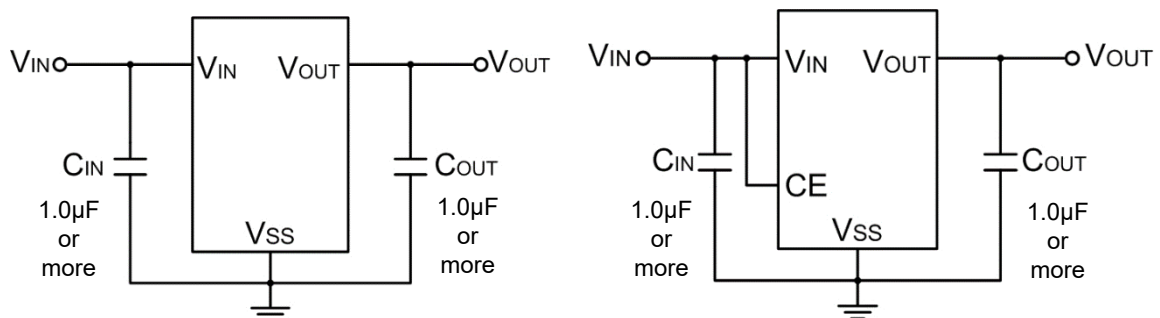

# Typical Characteristics

(Unless otherwise specified,  $T_A=25^\circ\text{C}$ )

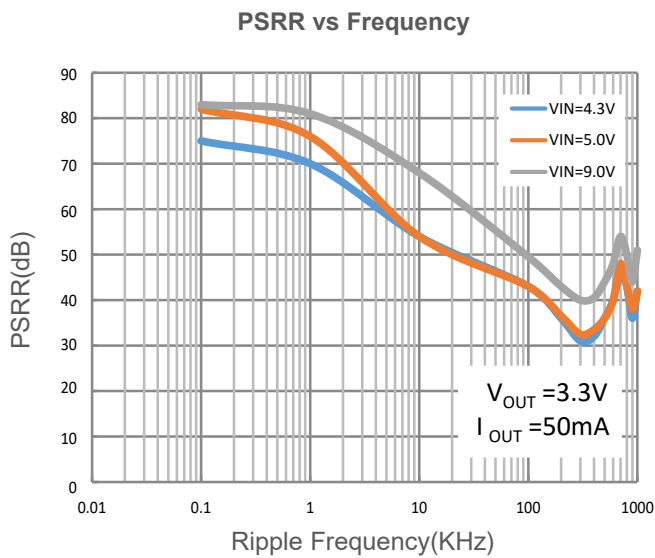
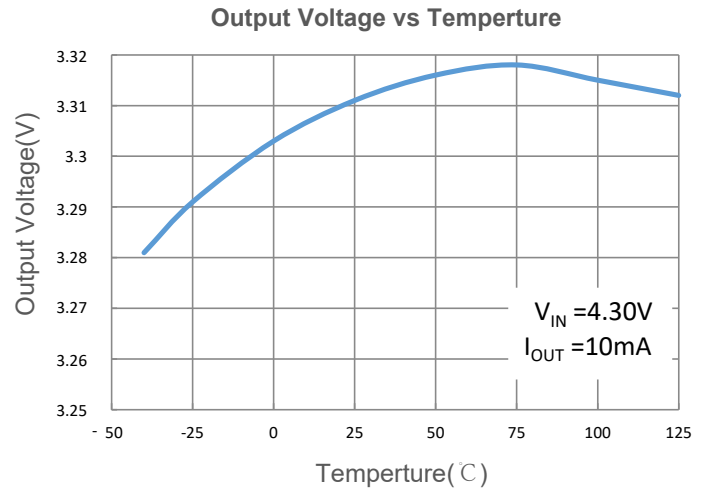
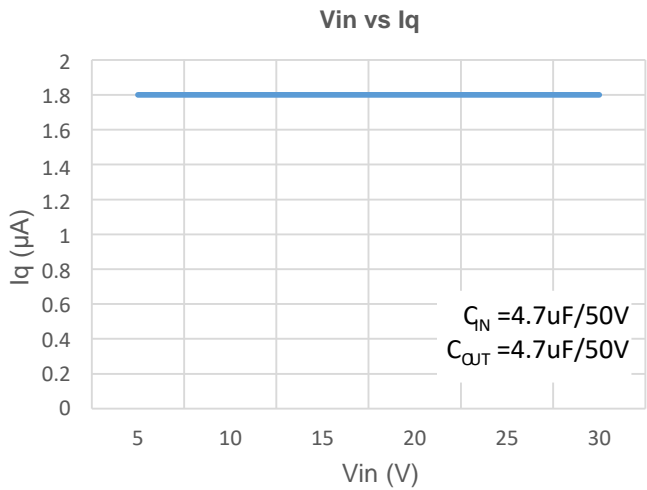
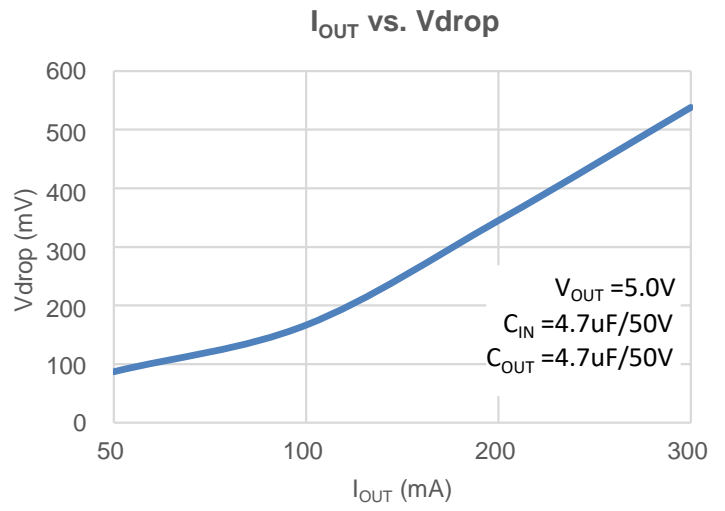
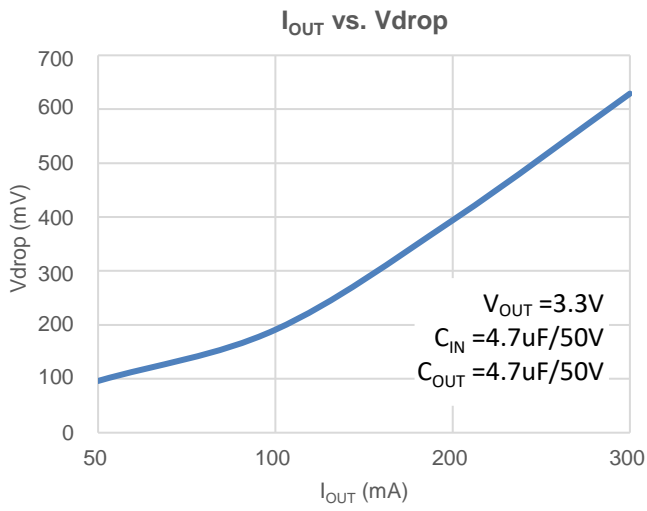

## Typical Characteristics

(Unless otherwise specified,  $T_A=25^\circ\text{C}$ )

Power Up Response

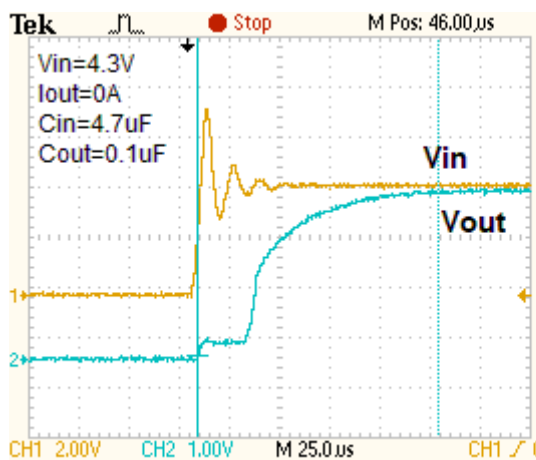

Power Up Response

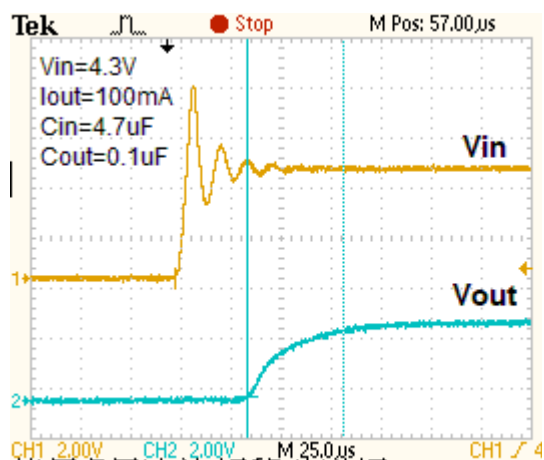

Load Transient Response

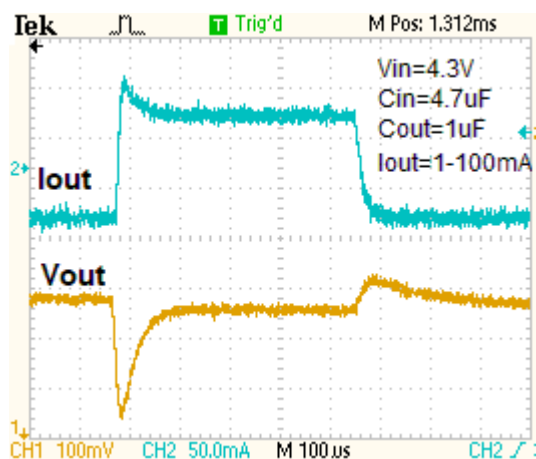

Load Transient Response

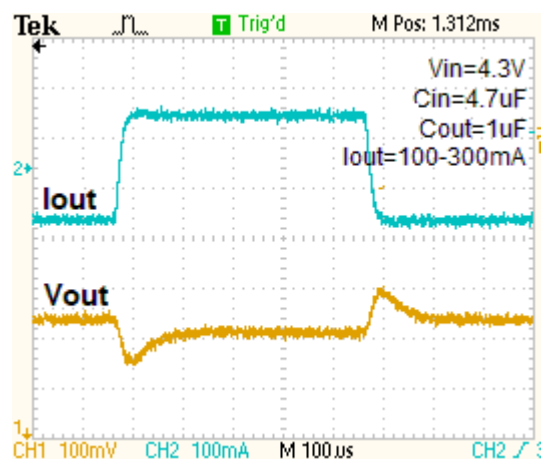

## SOT-23-3L Package Outline Dimensions

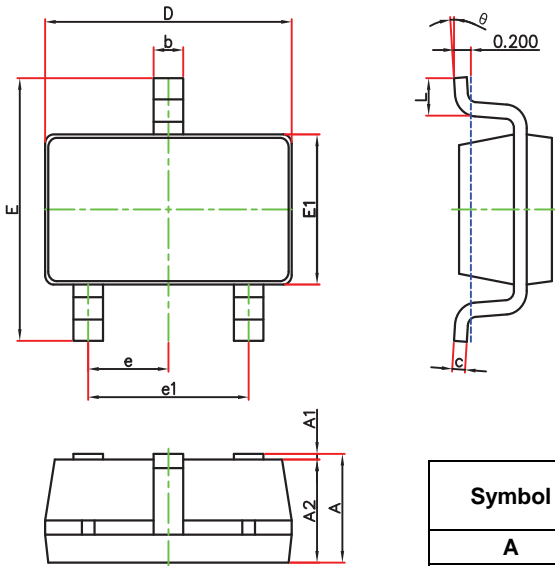

Symbol	Dimensions In Millimeters		Dimensions In Inches	
	Min.	Max.	Min.	Max.
A	1.050	1.250	0.041	0.049
A1	0.000	0.100	0.000	0.004
A2	1.050	1.150	0.041	0.045
b	0.300	0.500	0.012	0.020
c	0.100	0.200	0.004	0.008
D	2.820	3.020	0.111	0.119
E	2.650	2.950	0.104	0.116
E1	1.500	1.700	0.059	0.067
e	0.950(BSC)		0.037(BSC)	
e1	1.800	2.000	0.071	0.079
L	0.300	0.600	0.012	0.024
θ	0°	8°	0°	8°

## SOT-23-3L Suggested Pad Layout

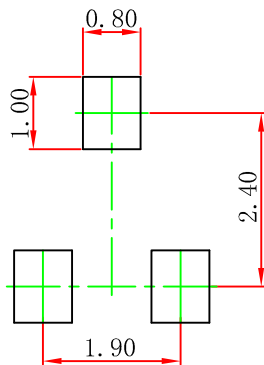

Note:

1. Controlling dimension: in millimeters.
2. General tolerance:  $\pm 0.05\text{mm}$ .
3. The pad layout is for reference purposes only.

## SOT-23-5L Package Outline Dimensions

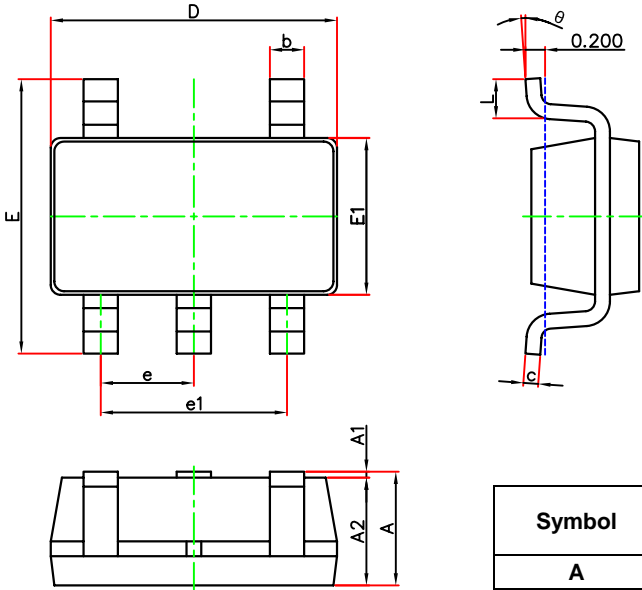

Symbol	Dimensions In Millimeters		Dimensions In Inches	
	Min.	Max.	Min.	Max.
A	1.050	1.250	0.041	0.049
A1	0.000	0.100	0.000	0.004
A2	1.050	1.150	0.041	0.045
b	0.300	0.500	0.012	0.020
c	0.100	0.200	0.004	0.008
D	2.820	3.020	0.111	0.119
E	2.650	2.950	0.104	0.116
E1	1.500	1.700	0.059	0.067
e	0.950(BSC)		0.037(BSC)	
e1	1.800	2.000	0.071	0.079
L	0.300	0.600	0.012	0.024
theta	0°	8°	0°	8°

## SOT-23-5L Suggested Pad Layout

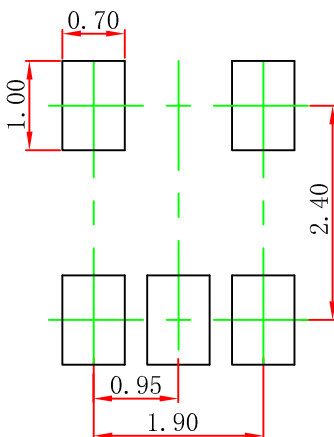

Note:

1. Controlling dimension: in millimeters.
2. General tolerance:  $\pm 0.05\text{mm}$ .
3. The pad layout is for reference purposes only.



## SOT-223 Package Outline Dimensions

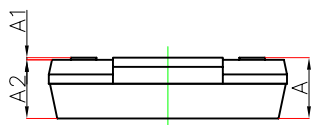
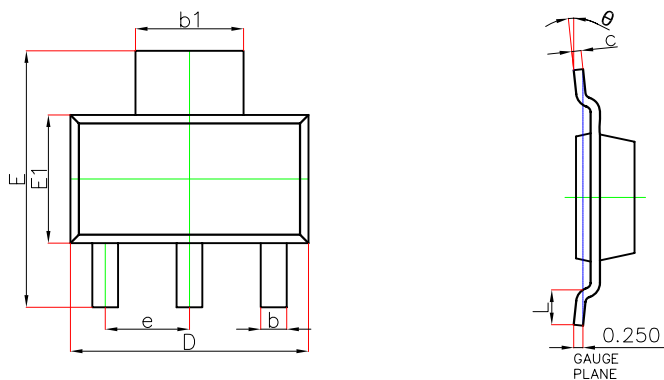

Symbol	Dimensions In Millimeters		Dimensions In Inches	
	Min.	Max.	Min.	Max.
A	—	1.800	—	0.071
A1	0.020	0.100	0.001	0.004
A2	1.500	1.700	0.059	0.067
b	0.660	0.840	0.026	0.033
b1	2.900	3.100	0.114	0.122
c	0.230	0.350	0.009	0.014
D	6.300	6.700	0.248	0.264
E	6.700	7.300	0.264	0.287
E1	3.300	3.700	0.130	0.146
e	2.300(BSC)		0.091(BSC)	
L	0.750	—	0.030	—
θ	0°	10°	0°	10°

## SOT-223 Suggested Pad Layout

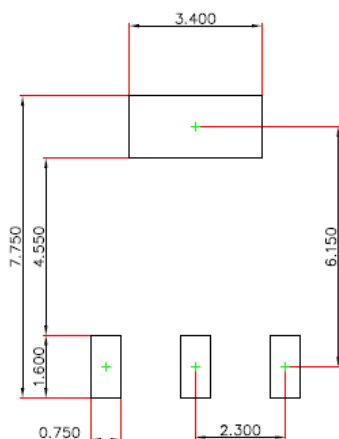

### Note:

1. Controlling dimension: in millimeters.
2. General tolerance:  $\pm 0.050$  mm.
3. The pad layout is for reference purposes only.

### NOTICE

JSCJ reserves the right to make modifications, enhancements, improvements, corrections or other changes without further notice to any product herein. JSCJ does not assume any liability arising out of the application or use of any product described herein.

## X-ON Electronics

Largest Supplier of Electrical and Electronic Components

*Click to view similar products for [Linear Voltage Regulators](#) category:*

*Click to view products by [Changjing Electronics Technology](#) manufacturer:*

Other Similar products are found below :

[LV5684PVD-XH](#) [MCDTSA6-2R](#) [L7815ACV-DG](#) [LV56801P-E](#) [UA7805CKC](#) [714954EB](#) [ZMR500QFTA](#) [BA033LBSG2-TR](#)

[NCV78M05ABDTRKG](#) [LV5680P-E](#) [L79M05T-E](#) [L78LR05D-MA-E](#) [NCV317MBTG](#) [NTE7227](#) [MP2018GZD-33-P](#) [MP2018GZD-5-P](#)

[LV5680NPVC-XH](#) [ZTS6538SE](#) [UA78L09CLP](#) [UA78L09CLPR](#) [CAT6221-PPTD-GT3](#) [MC78M09CDTRK](#) [NCV51190MNTAG](#)

[BL1118CS8TR1833](#) [BL8563CKETR18](#) [BL8077CKETR33](#) [BL9153-33CC3TR](#) [BL9161G-15BADRN](#) [BL9161G-28BADRN](#)

[BRCO7530MMC](#) [CJ7815B-TFN-ARG](#) [LM317C](#) [GM7333K](#) [GM7350K](#) [XC6206P332MR](#) [HT7533](#) [LM7912S/TR](#) [LT1764S/TR](#) [LM7805T](#)

[LM338T](#) [LM1117IMP-3.3/TR](#) [HT1117AM-3.3](#) [HT7550S](#) [AMS1117-3.3](#) [HT7150S](#) [78L12](#) [HT7550](#) [HT7533-1](#) [HXY6206I-2.5](#) [HT7133](#)