



CJ6385 Series Low-dropout Regulators

1 Introduction

The CJ6385 series is a low dropout linear regulator manufactured by CMOS process. Its input voltage can be as high as 40V. Under the condition of good heat dissipation, it can also provide 200mA current. The CJ6385 series has quiescent current as low as 2.0 μ A, and integrates thermal shutdown protection and short circuit protection internally. Therefore, the CJ6385 series is very suitable for battery powered equipment, such as RF applications and other systems requiring low power consumption voltage sources.

2 Available Packages

PART NUMBER	PACKAGE
CJ6385 Series	SOT-23-3L
	SOT-89-3L

Note: For all available packages, please refer to the part *Orderable Information*.

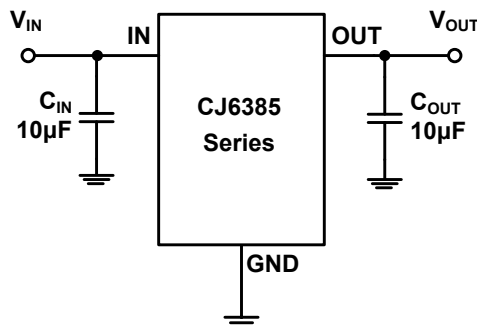

Typical Application Circuit

3 Features

- Input Voltage Range: 3.0 ~ 40V
- Output Voltage:
 - Available from 2.8V to 9.0V
 - Output Tolerance: $\pm 2\%$
- Output Current: up to 200mA
- Quiescent Current: 2.0 μ A (Typ.)
- Dropout Voltage: 400mV@50mA
- Power Supply Rejection Ratio: 75dB@100Hz
- Good Transient Response
- Integrated Fault Protection:
 - Build-in Current Limit
 - Short-Circuit Protection
 - Thermal Shutdown

4 Applications

- Electricity, Water and Gas Meters
- Fire Alarm, Smoke Detector
- Household Electric Appliances
- LAN Card
- Portable Audio and Video Equipment
- Radio Control System
- Low Power Micro-controller
- Wireless Communication Equipment

5 Orderable Information

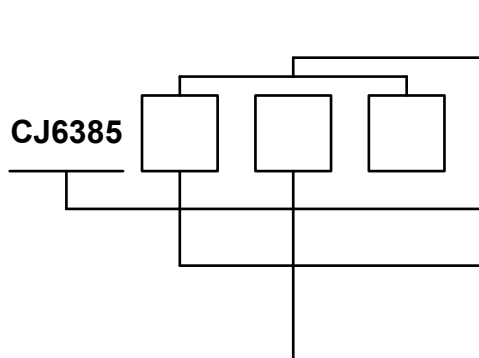

Package type.
 A□M: SOT-23-3L
 A□P: SOT-89-3L
 A□G: SOT-223
 A□MF / A□MR: SOT-23-5L

Device serial number.

Enable function marking.
 A: Normal device

Output voltage.
 30: Fixed output 3.0V
 33: Fixed output 3.3V
 36: Fixed output 3.6V
 50: Fixed output 5.0V

Figure 5-1. Naming Conventions

MODEL	DEVICE	PACKAGE	OP TEMP	ECO PLAN	MSL	PACKING OPTION	SORT
CJ6385-3.0	CJ6385A30M	SOT-23-3L	-40 ~ 85°C	RoHS & Green	Level 3 168 HR	Tape and Reel 3000 Units / Reel	Active
CJ6385-3.3	CJ6385A33M	SOT-23-3L	-40 ~ 85°C	RoHS & Green	Level 3 168 HR	Tape and Reel 3000 Units / Reel	Active
CJ6385-3.6	CJ6385A36M	SOT-23-3L	-40 ~ 85°C	RoHS & Green	Level 3 168 HR	Tape and Reel 3000 Units / Reel	Active
CJ6385-5.0	CJ6385A50M	SOT-23-3L	-40 ~ 85°C	RoHS & Green	Level 3 168 HR	Tape and Reel 3000 Units / Reel	Active
CJ6385-3.0	CJ6385A30P	SOT-89-3L	-40 ~ 85°C	RoHS & Green	Level 3 168 HR	Tape and Reel 1000 Units / Reel	Active
CJ6385-3.3	CJ6385A33P	SOT-89-3L	-40 ~ 85°C	RoHS & Green	Level 3 168 HR	Tape and Reel 1000 Units / Reel	Active
CJ6385-3.6	CJ6385A36P	SOT-89-3L	-40 ~ 85°C	RoHS & Green	Level 3 168 HR	Tape and Reel 1000 Units / Reel	Active
CJ6385-5.0	CJ6385A50P	SOT-89-3L	-40 ~ 85°C	RoHS & Green	Level 3 168 HR	Tape and Reel 1000 Units / Reel	Active

5 Orderable Information

MODEL	DEVICE	PACKAGE	OP TEMP	ECO PLAN	MSL	PACKING OPTION	SORT
Customized Products							
Output available from 2.8V to 9.0V		SOT-23-3L	-40 ~ 85°C	RoHS & Green	Level 3 168 HR	Tape and Reel 3000 Units / Reel	Customized
		SOT-89-3L	-40 ~ 85°C	RoHS & Green	Level 3 168 HR	Tape and Reel 1000 Units / Reel	Customized
		SOT-223	-40 ~ 85°C	RoHS & Green	Level 3 168 HR	-	Customized
		SOT-23-5L	-40 ~ 85°C	RoHS & Green	Level 3 168 HR	-	Customized
		TO-92	-40 ~ 85°C	RoHS & Green	Level 3 168 HR	-	Customized
Others	-	-	-	-	-	-	Customized

Note:

ECO PLAN: For the RoHS and Green certification standards of this product, please refer to the official report provided by JSCJ.

MSL: Moisture Sensitivity Level. Determined according to JEDEC industry standard classification.

SORT: Specifically defined as follows:

Active: Recommended for new products;

Customized: Products manufactured to meet the specific needs of customers;

Preview: The device has been released and has not been fully mass produced. The sample may or may not be available;

NoRD: It is not recommended to use the device for new design. The device is only produced for the needs of existing customers;

Obsolete: The device has been discontinued.

6 Pin Configuration and Marking Information

6.1 Pin Configuration

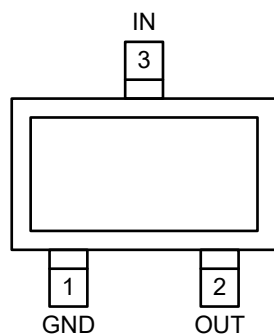

CJ6385AxxM
SOT-23-3L

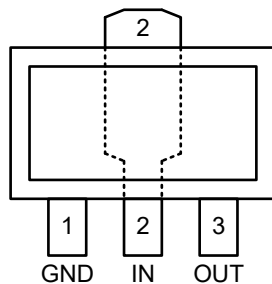

CJ6385AxxP
SOT-89-3L

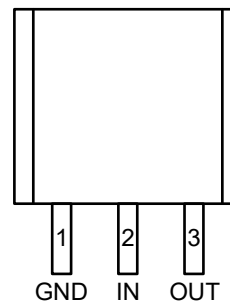

CJ6385AxxT
TO-92

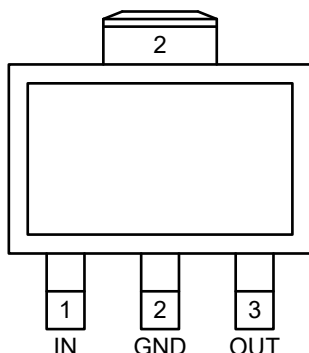

CJ6385AxxG
SOT-223

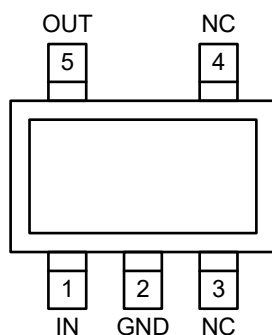

CJ6385AxxMF
SOT-23-5L

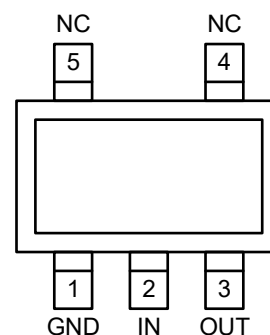

CJ6385AxxMR
SOT-23-5L

(Not to Scale)

6.2 Pin Function

PIN NAME	I / O	CJ6385 Series Pin Function
		DESCRIPTION
IN	I	Input to the device. Use the recommended value of the input capacitor and place it as close to the input of the device as possible to reduce the impedance of the input supply.
GND	-	Regulator ground.
NC	-	No internal connection. This pin can float, but when this pin is connected to GND, the device has better thermal performance.
OUT	O	Output of the regulator. An output capacitor is required for stability and help device obtain the best transient response. Use the capacitor with the recommended value and place it as close as possible to the output.

6 Pin Configuration and Marking Information

6.3 Marking Information

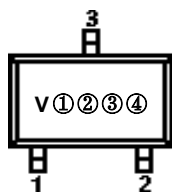

SOT-23-3L

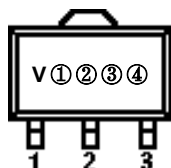

SOT-89-3L

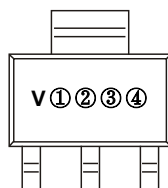

SOT-223

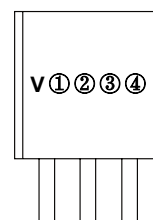

TO-92

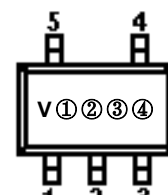

SOT-23-5L

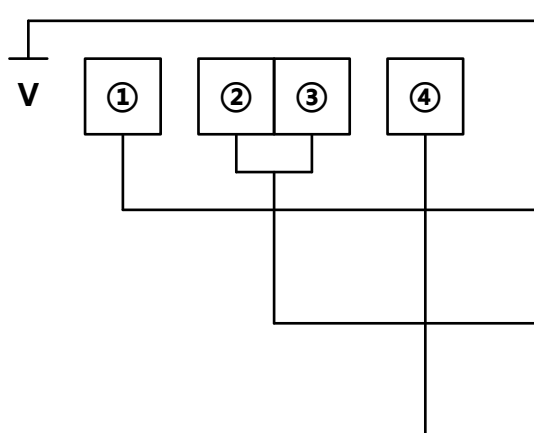

Serial code for CJ6385 series.

Representative output voltage.

- G: Fixed output 3.0V
- H: Fixed output 3.3V
- I: Fixed output 3.6V
- K: Fixed output 5.0V
- (Other products are customized)

Code, indicates weekly record information of production.

Code, special pin arrangement sequence.

- (blank): Normal
- F: MF pin arrangement for SOT-23-5L
- R: MR pin arrangement for SOT-23-5L

Output Voltage	Marking Information for CJ6385 Series		
	3 Pins Packages		Others
	SOT-23-3L	SOT-89-3L	
3.0V	CJ6385A30M: VGXX	CJ6385A30P: VGXX	-
3.3V	CJ6385A33M: VHXX	CJ6385A33P: VHXX	-
3.6V	CJ6385A36M: VIXX	CJ6385A36P: VIXX	-
5.0V	CJ6385A50M: VKXX	CJ6385A50P: VKXX	-

7 Specifications

7.1 Absolute Maximum Ratings

(over operating free-air temperature range, unless otherwise specified)⁽¹⁾

CHARACTERISTIC		SYMBOL	VALUE	UNIT	
Input voltage ⁽²⁾		V_{IN}	-0.3 ~ 45	V	
Output voltage ⁽²⁾		V_{OUT}	-0.3 ~ 15		
Maximum power dissipation	CJ6385 Series	SOT-23-3L	$P_{D\ Max}$	Internally Limited ⁽³⁾	W
		SOT-89-3L			
		SOT-223			
		TO-92			
		SOT-23-5L			
Maximum junction temperature		$T_{J\ Max}$	125	°C	
Storage temperature		T_{stg}	-50 ~ 125	°C	
Soldering temperature & time		T_{solder}	260°C, 10s	-	

(1) Stresses beyond those listed under *Absolute Maximum Ratings* may cause permanent damage to the device. These are stress ratings only, which do not imply functional operation of the device at these or any other conditions beyond those indicated under *Recommended Operating Conditions*. Exposure to absolute-maximum rated conditions for extended periods may affect device reliability.

(2) All voltages are with respect to network ground terminal.

(3) Refer to *Thermal Information* for details.

7.2 Recommended Operating Conditions

PARAMETER	SYMBOL	MIN.	NOM.	MAX.	UNIT
Input voltage	V_{IN}	3.0	-	40	V
Operating junction temperature	T_J	-40	-	125	°C
Operating ambient temperature ⁽⁴⁾	T_A	-40	-	85	°C

(4) It is necessary to ensure that the operating junction temperature of the device does not exceed the rated value of the recommended operating conditions when using the device for design.

7 Specifications

7.3 ESD Ratings

ESD RATINGS		SYMBOL	VALUE	UNIT
Electrostatic discharge ⁽⁵⁾	Human body model	$V_{ESD-HBM}$	2000	V
	Machine model	V_{ESD-MM}	200	

(5) ESD testing is conducted in accordance with the relevant specifications formulated by the Joint Electronic Equipment Engineering Commission (JEDEC). The human body model (HBM) electrostatic discharge test is based on the JESD22-114D test standard, using a 100pF capacitor and discharging to each pin of the device through a resistance of 1.5kΩ. The electrostatic discharge test in mechanical model (MM) is based on the JESD22-115-A test standard and uses a 200pF capacitor to discharge directly to each pin of the device.

7.4 Thermal Information

THERMAL METRIC ⁽⁶⁾	SYMBOL	CJ6385 Series			UNIT
		SOT-23-3L	SOT-89-3L	SOT-223	
Junction-to-ambient thermal resistance	$R_{\theta JA}$				°C/W
		261.1	161.3	100.8	
		TO-92	SOT-23-5L	-	
		166.9	253.6		
Junction-to-case thermal resistance	$R_{\theta JC}$				°C/W
		64.8	51.5	18.6	
		TO-92	SOT-23-5L	-	
		44.0	64.9		
Reference maximum power dissipation for continuous operation	$P_{D Ref}$				W
		0.38	0.63	1.00	
		TO-92	SOT-23-5L	-	
		0.60	0.40		

(6) Thermal metric is measured in still air with $T_A = 25^\circ\text{C}$ and mounted on a 1 in² FR-4 substrate PCB covered with 2 ounces of copper.

7 Specifications

7.5 Electrical Characteristics

CJ6385 Series ($V_{IN} = V_{OUT} + 2V$, $C_{IN} = 10\mu F$, $C_{OUT} = 10\mu F$, $T_A = 25^\circ C$, unless otherwise specified)

CHARACTERISTIC	SYMBOL	TEST CONDITIONS		MIN.	TYP. ⁽⁷⁾	MAX.	UNIT
Input voltage	V_{IN}	-		3.0	-	40	V
DC output tolerance	-	$T_J = 25^\circ C$		-2	-	2	%
Output current	I_{OUT}	$T_J = 25^\circ C$		200	-	-	mA
Output current limit	$I_{OUT\ Limit}$	$V_{IN} = V_{OUT} + 2V$, $T_J = 25^\circ C$		300	350	-	mA
Quiescent current	I_Q	$I_{OUT} = 0mA$		-	2.0	3.5	μA
Dropout voltage	$V_{DIF}^{(8)}$	$V_{OUT} \leq 3.0V$	$I_{OUT} = 1mA$	-	30	100	mV
			$I_{OUT} = 1mA$	-	25	60	
		$V_{OUT} > 3.0V$	$I_{OUT} = 50mA$	-	400	-	
			$I_{OUT} = 100mA$	-	700	-	
Line regulation	$LNR^{(9)}$	$V_{IN} = V_{OUT} + 2V$ to 40V, $I_{OUT} = 1mA$		-	0.01	0.20	%/V
Load regulation	ΔV_{LOAD}	$V_{IN} = V_{OUT} + 2V$, $I_{OUT} = 1$ to 100mA		-	50	-	mV
Temperature characteristics	$TR^{(10)}$	$V_{IN} = V_{OUT} + 2V$, $I_{OUT} = 10mA$, $T_A = -40$ to $85^\circ C$		-	100	-	ppm/ $^\circ C$
Short current	I_{Short}	V_{OUT} short to GND		-	125	-	mA
Power supply rejection ratio	PSRR	$I_{OUT} = 50mA$, $V_{IN} = 12V_{DC} + 1V_{PP\ AC}$	$f = 100Hz$	-	75	-	dB
			$f = 1kHz$	-	55	-	
Junction shutdown temperature	T_{SD}	-		-	150	-	$^\circ C$
Hysteresis of thermal shutdown	T_{HYST}	-		-	20	-	$^\circ C$

Note:

(7) Typical numbers are at 25°C and represent the most likely norm.

(8) Test the difference of output voltage and input voltage when input voltage is decreased gradually till output voltage equals to 98% of $V_{OUT(NOM)}$.

(9) The line regulation is calculated by the following formula:

$$LNR = \frac{\Delta V_{OUT}}{V_{OUT} \times \Delta V_{IN}}$$

where, ΔV_{OUT} is the variation of the output voltage, ΔV_{IN} is the variation of the input voltage.

(10) The output voltage temperature characteristics (TR) is calculated by the following formula:

$$TR = \frac{\Delta V_{OUT}}{V_{OUT} \times \Delta T}$$

where, ΔV_{OUT} is the variation of the output voltage, ΔT is the variation of the ambient temperature.

7 Specifications

7.6 Typical Characteristics

CJ6385 Series ($V_{OUT} = 3.3V$, $C_{IN} = 10\mu F$, $C_{OUT} = 10\mu F$, $T_A = 25^\circ C$, unless otherwise specified)

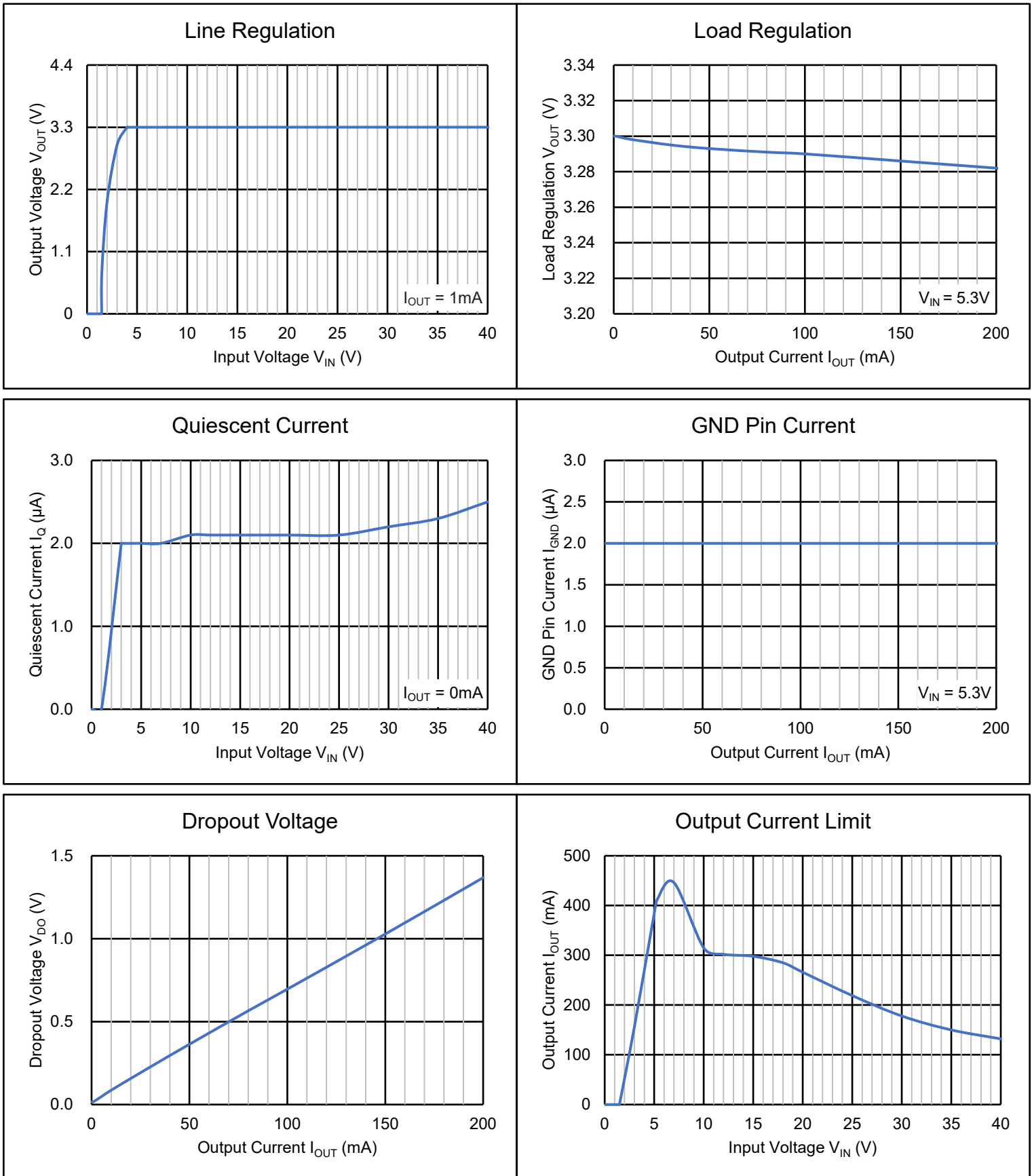

7 Specifications

7.6 Typical Characteristics (continued)

CJ6385 Series ($V_{OUT} = 3.3V$, $C_{IN} = 10\mu F$, $C_{OUT} = 10\mu F$, $T_A = 25^\circ C$, unless otherwise specified)

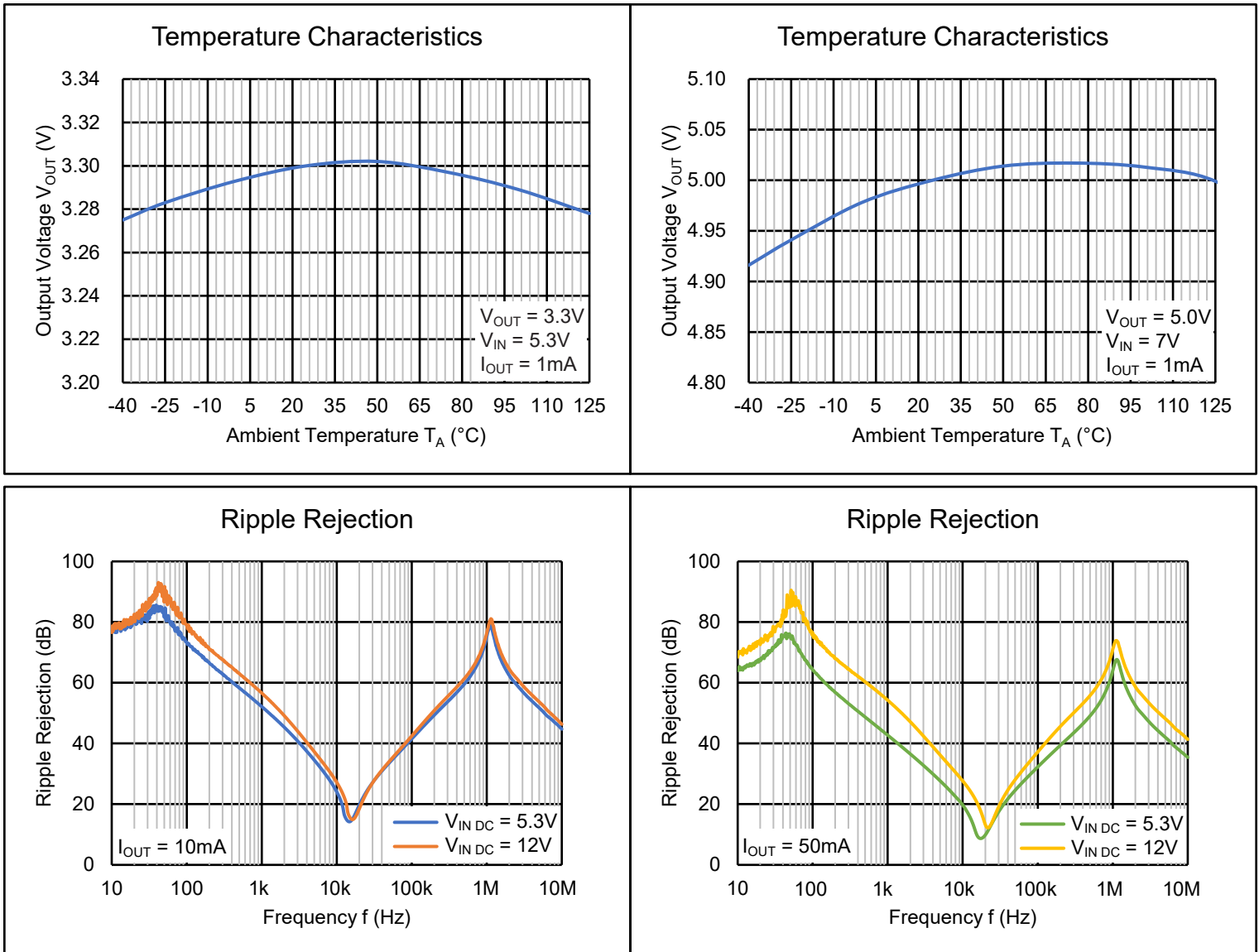

7 Specifications

7.6 Typical Characteristics (continued)

CJ6385 Series ($V_{OUT} = 3.3V$, $C_{IN} = 10\mu F$, $C_{OUT} = 10\mu F$, $T_A = 25^\circ C$, unless otherwise specified)

Load Transient

$V_{OUT} = 3.3V$, $V_{IN} = 5.3V$, CH2: V_{OUT} , CH4: I_{OUT}

$I_{OUT} = 1 \sim 100mA$

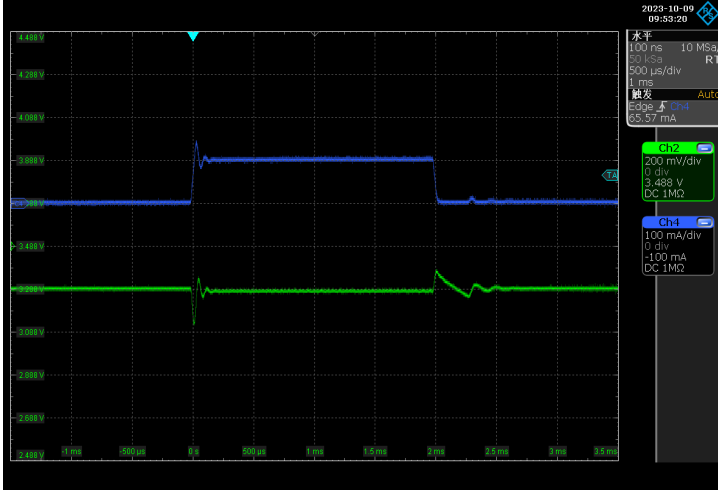

$I_{OUT} = 10 \sim 100mA$

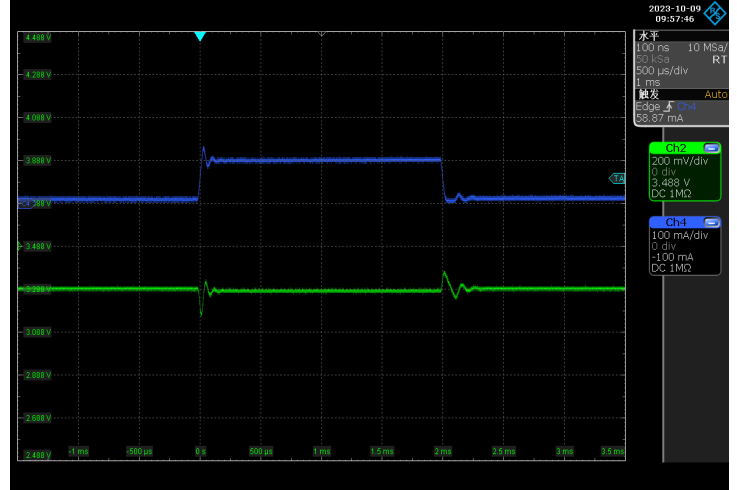

$I_{OUT} = 40 \sim 160mA$

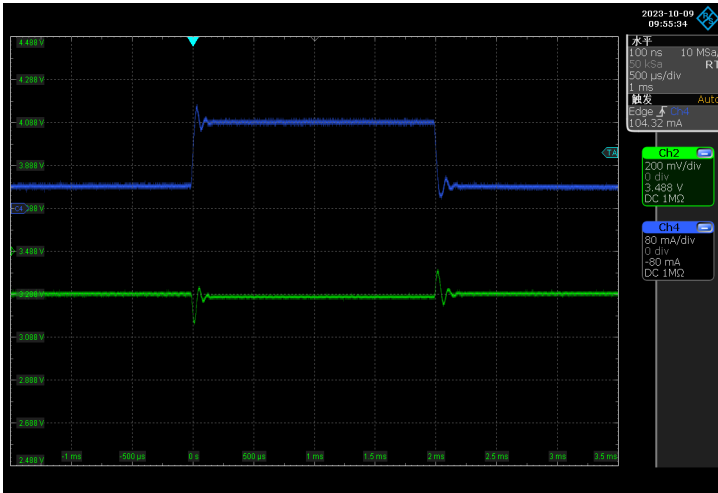

$I_{OUT} = 100 \text{ to } 200mA$

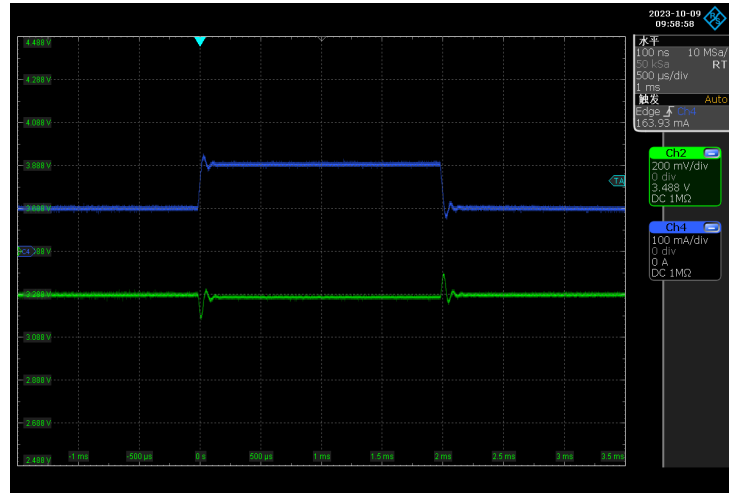

Power-up Response

$V_{OUT} = 3.3V$, $V_{IN} = 0 \sim 30V$, $R_{IN} = 1\Omega$, CH1: V_{IN} , CH2: V_{OUT}

$I_{OUT} = 0mA$

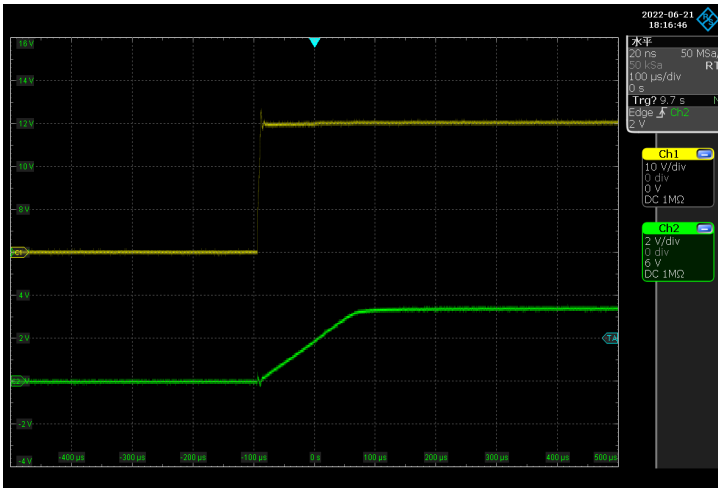

$I_{OUT} = 100mA$

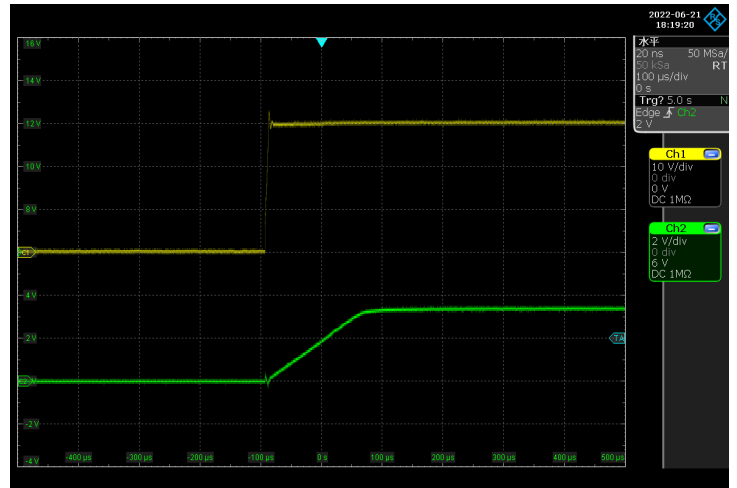

8 Detailed Description

8.1 Description

The CJ6385 series is a low-dropout linear regulator (LDO) with a wide input voltage range of up to 40V, which is manufactured by CMOS process. The internal feedback resistor R_S and R_F form a voltage dividing circuit to compare the V_{FB} input error amplifier with the reference voltage V_{REF} . The internal adjustment tube (PMOS) will control its conduction degree through the gate voltage provided by the output of the error amplifier, which will make the output voltage V_{OUT} unaffected by the temperature change or input voltage change to a certain extent, so as to maintain the stability of the device output voltage.

8.2 Functional Block Diagram

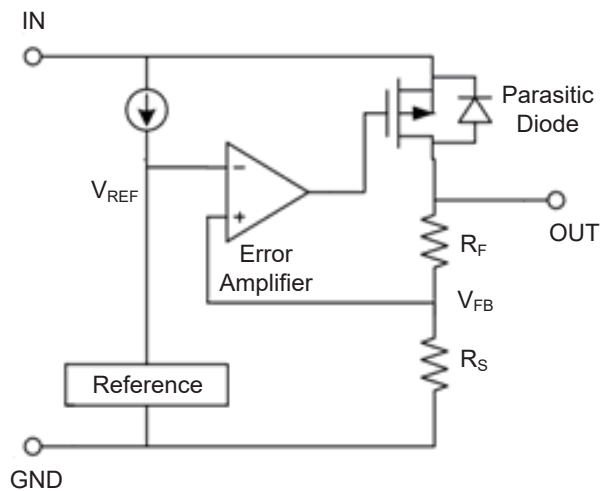

8.3 Feature Description

Input Voltage

If the input voltage is lower than the nominal output voltage plus the specified dropout voltage, but all other conditions are met for normal operation, the device operates in dropout mode. In this condition, the output voltage is the same the input voltage minus the dropout voltage. The transient performance of the device is significantly degraded because the pass device is in a triode state and no longer controls the current through the LDO. Line or load transients in dropout may result in large output voltage deviations.

If the input voltage is higher than the rated range of the data sheet, the device may cause irreversible damage or failure due to exceeding the maximum rated range of electrical stress.

Reverse Diode

The regulator PMOS inside the CJ6385 series contains a parasitic diode that conducts the reverse current that may be generated in the device when the input voltage drops below the output voltage (e.g. during power failure). At this time, the current is conducted from the output end to the input end without internal restriction. If extended reverse voltage operation is anticipated, external limiting is appropriate.

8 Detailed Description

8.3 Feature Description (continued)

Integrated Fault Protection

Built-in Current Limit:

The CJ6385 series has internal current limiting function. During normal operation, the output current of the device will be limited to about 350mA (typical). When the output current exceeds the current limit, the device will enter an over-current state and the output voltage will be reduced to nearly 0V. When the over-current state ends, the device will return to normal output.

Thermal Shutdown:

When the junction temperature of the device is high, the output voltage of the device will decrease linearly. When the junction temperature of the device exceeds the rated range of the data sheet, the device will enter the thermal shutdown mode and the output voltage will be reduced to nearly 0V. When the junction temperature drops to the rated range, the device will release the thermal shutdown state and return to normal output.

Short Circuit Protection:

When the output of the device is short circuited to the ground, the device will enter the short-circuit protection state. At this time, the output of the device will be reduced to close to 0V, and the output current will remain within a certain range.

Usage:

Due to the thermal shutdown protection mechanism, when the output current is large, the device may enter the thermal shutdown state before entering the over-current state. Therefore, appropriate packaging should be selected to help the device emit more heat, so as to ensure the maximum load current capacity of the device. Although thermal shutdown and short-circuit protection can prevent the possibility of accidental damage to devices to a certain extent, continuous operation of the equipment under junction temperature exceeding 125°C will reduce the reliability of the equipment. Therefore, the rated maximum operating contact temperature of 125°C shall not be exceeded.

9 Application and Implementation

9.1 Typical Application Circuit

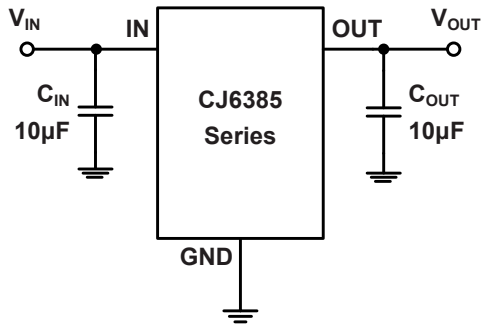

(1) Conventional Circuit
Used for the normal form of circuit

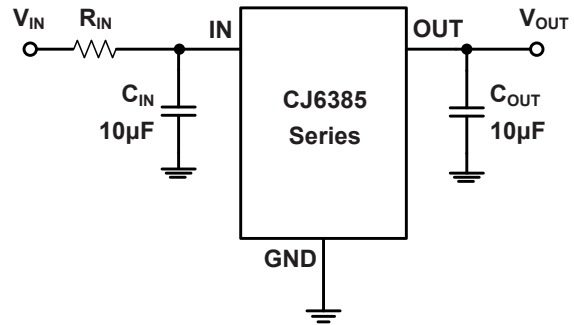

(2) Resistance are used at IN
Used for circuits that may have large electrical surges or use large capacitors

Figure 9-1. Fixed Output Regulator

9.2 Risk Alert and Precautions

Instantaneous Electrical Surge

In some applications, a short duration but high energy spike may occur in the circuit, including peak voltage and surge current. They may cause unstable operation of the regulator, accelerated aging and potential hazards, and even damage or malfunction of the regulator. These peaks are usually more likely to occur in hot-plug, switch inductance, heavy-load, and other types of circuits.

In the practical application of the circuit, place a resistor with appropriate resistance in series before the IN of the voltage regulator, which can help the voltage regulator share part of the energy in case of surge. The resistance value of the resistance should not be too large. The specific resistance value depends on the application of the circuit. Generally, the resistance value of this resistance does not exceed 20Ω. As shown in Figure 9-1-(2).

For the CJ6385 series, it is recommended that the input voltage should not exceed 20V and the peak voltage should not exceed 40V. **When the input voltage is greater than 20V, or the peak voltage that may be greater than 40V may appear in the practical circuit, it is recommended to adopt the circuit layout shown in Figure 9-1-(2) in the circuit design.**

Large Output Capacitance

The CJ6385 series can obtain better transient response with the help of output capacitance. However, if the output capacitor is relatively large, the surge current generated by the charging of the output capacitor will also be large at the moment of power on of the regulator, and the large surge current passing through the regulator may damage the internal circuit. When the output capacitance is large, adopting the circuit design shown in Figure 9-1-(2) will reduce the possibility of damage to the device due to large surge current to a certain extent. It is recommended that the selection of output capacitor should not exceed 20µF. **If the selection of output capacitor exceeds 20µF, it is recommended to adopt the circuit design in Figure 9-1-(2) to reduce the possibility of accidental failure of the device due to large surge current during power on.**

9 Application and Implementation

9.2 Risk Alert and Precautions (continued)

Figure 9-2 and Figure 9-3 show the impact of not using R_{IN} [Test circuit is shown in Figure 9-1-(1)] and using R_{IN} [Test circuit is shown in Figure 9-1-(2)] on suppressing surge voltage.

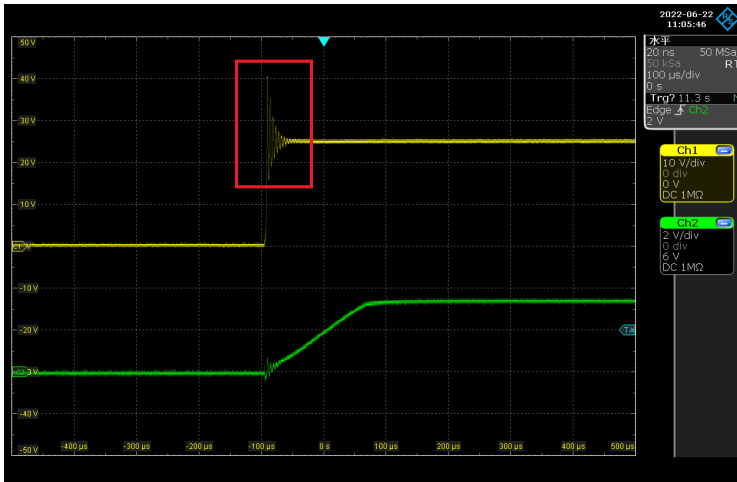

Figure 9-2. Test with The Conventional Circuit [Figure 9-1-(1)]

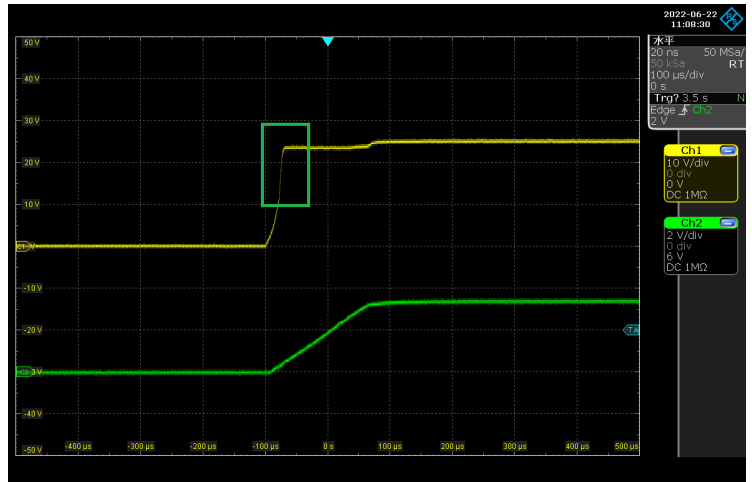

Figure 9-3. Test with the Circuit that 5Ω Resistance are used at IN [Figure 9-1-(2)]

As shown in Figure 9-2., when the input is powered on from 0 to 25V, a very high peak voltage (shown in the red part) is generated in front of the input terminal of the device, and the maximum peak voltage is far more than 25V. When R_{IN} is used, as shown in Figure 9-3., the peak voltage generated by power on is effectively suppressed (shown in the green part).

9.3 Input and Output Capacitor Requirements

The CJ6385 series requires a capacitor of $1\mu\text{F}$ or greater ($10\mu\text{F}$ is recommended for C_{IN}) to be connected between OUT and GND to maintain stability. Ceramic or tantalum capacitors can be used. The larger the capacitance, the better the transient and noise performance. However, when the input capacitance is large, the circuit shown in figure 9-1-(2) may be required. See *Large Output Capacitance* for details.

Although stability does not require an input capacitor, when a capacitor of $1\mu\text{F}$ or greater is placed between in and GND ($10\mu\text{F}$ is recommended for C_{OUT}), it will offset the reactive input source and improve transient and noise performance. If a large fast rise time load transient is expected, a higher value capacitor is required.

NOTE

The application information in this section is not part of the data sheet component specification, and JSCJ makes no commitment or statement to guarantee its accuracy or completeness. Customers are responsible for determining the rationality of corresponding components in their circuit design and making tests and verifications to ensure the normal realization of their circuit design.

10 Mechanical Information

10.1 SOT-23-3L Mechanical Information

SOT-23-3L Outline Dimension

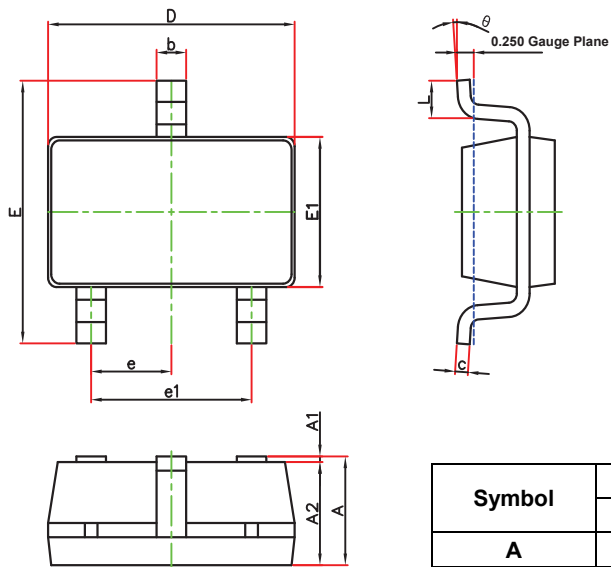

Symbol	Dimensions In Millimeters		Dimensions In Inches	
	Min.	Max.	Min.	Max.
A	0.900	1.450	0.035	0.057
A1	0.000	0.150	0.000	0.006
A2	0.900	1.300	0.035	0.051
b	0.350	0.500	0.014	0.020
c	0.100	0.200	0.004	0.008
D	2.820	3.020	0.111	0.119
E	2.600	3.000	0.102	0.118
E1	1.500	1.700	0.059	0.067
e	0.950(BSC)		0.037(BSC)	
e1	1.800	2.000	0.071	0.079
L	0.350	0.550	0.014	0.022
θ	0°	8°	0°	8°

SOT-23-3L Suggested Pad Layout

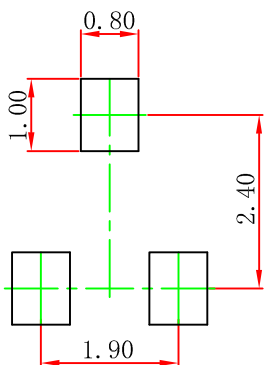

Note:

1. Controlling dimension: in millimeters.
2. General tolerance: ±0.05mm.
3. The pad layout is for reference purpose only.

10 Mechanical Information

10.2 SOT-89-3L Mechanical Information

SOT-89-3L Outline Dimension

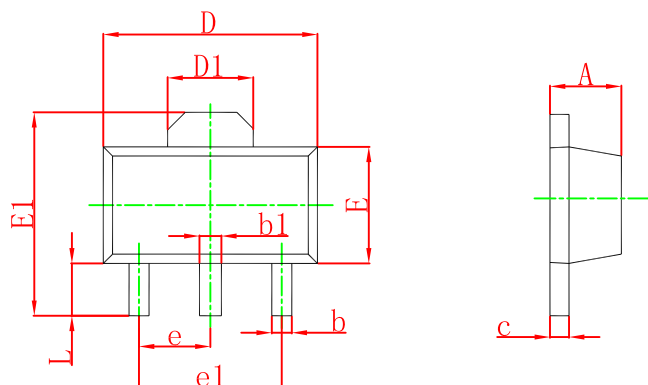

Symbol	Dimensions In Millimeters		Dimensions In Inches	
	Min.	Max.	Min.	Max.
A	1.400	1.600	0.055	0.063
b	0.350	0.500	0.014	0.020
b1	0.450	0.600	0.018	0.024
c	0.360	0.460	0.014	0.018
D	4.300	4.700	0.169	0.185
D1	1.400	1.800	0.055	0.071
E	2.300	2.700	0.091	0.106
E1	4.000	4.700	0.157	0.185
e	1.500 BSC		0.059 BSC	
e1	3.000 BSC		0.118 BSC	
L	0.800	1.200	0.031	0.047

SOT-89-3L Suggested Pad Layout

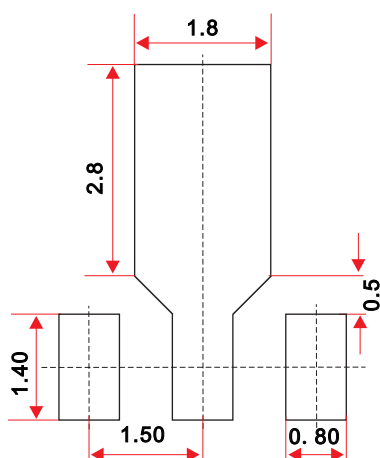

Note:

1. Controlling dimension: in millimeters.
2. General tolerance: $\pm 0.05\text{mm}$.
3. The pad layout is for reference purpose only.

11 Packaging Information

11.1 SOT-23-3L Tape and Reel Information

SOT-23-3L Embossed Carrier Tape

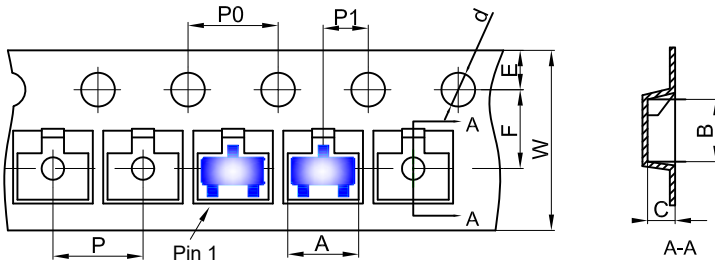

Packaging Description:
 SOT-23-3L parts are shipped in tape. The carrier tape is made from a dissipative (carbon filled) polycarbonate resin. The cover tape is a multilayer film (Heat Activated Adhesive in nature) primarily composed of polyester film, adhesive layer, sealant, and anti-static sprayed agent. These reeled parts in standard option are shipped with 3,000 units per 7" or 18.0cm diameter reel. The reels are clear in color and is made of polystyrene plastic (anti-static coated).

Dimensions are in millimeter										
Pkg type	A	B	C	d	E	F	P0	P	P1	W
SOT-23-3L	3.10	3.20	1.40	Φ1.55	1.75	3.50	4.00	4.00	2.00	8.00

SOT-23-3L Tape Leader and Trailer

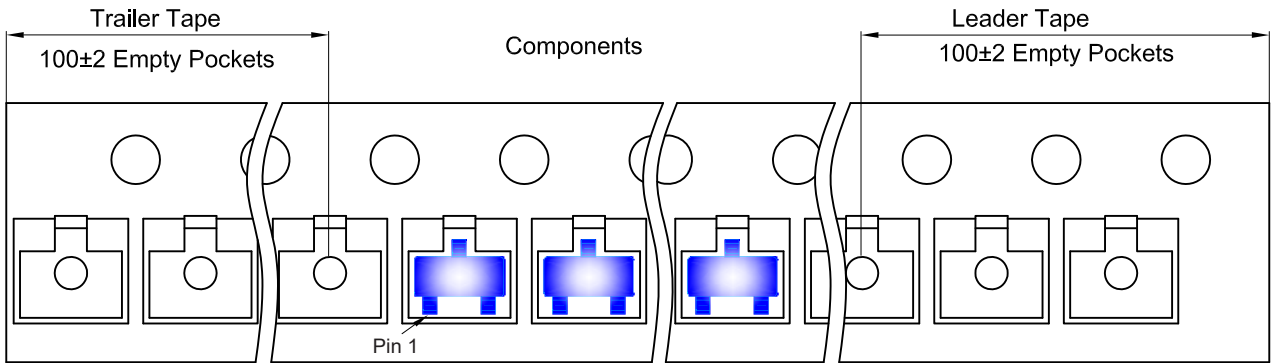

SOT-23-3L Reel

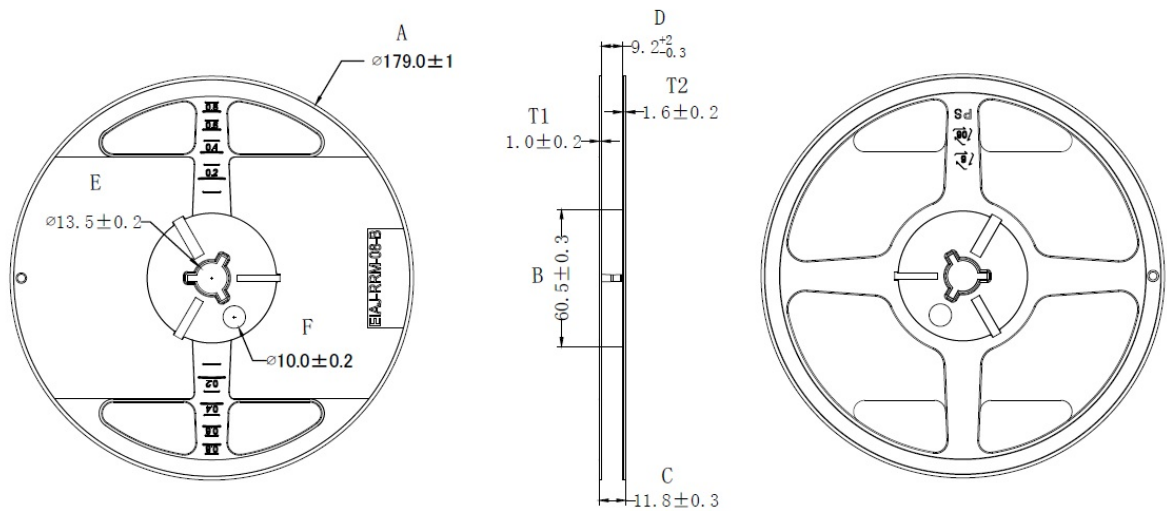

A ± 1	B ± 0.3	C ± 0.3	D ⁺² _{-0.3}	E ± 0.2	F ± 0.2	T1 ± 0.2	T2 ± 0.2
179	60.5	11.8	9.2	13.5	∅10	1.0	1.6

REEL	Reel Size	Box	Box Size(mm)	Carton	Carton Size(mm)	G.W.(kg)
3000 pcs	7 inch	30,000 pcs	203×203×195	120,000 pcs	438×438×220	

11 Packaging Information

11.2 SOT-89-3L Tape and Reel Information

SOT-89-3L Embossed Carrier Tape

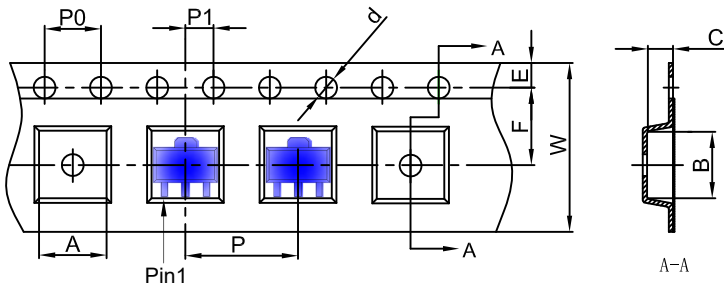

Packaging Description:
 SOT-89-3L parts are shipped in tape. The carrier tape is made from a dissipative (carbon filled) polycarbonate resin. The cover tape is a multilayer film (Heat Activated Adhesive in nature) primarily composed of polyester film, adhesive layer, sealant, and anti-static sprayed agent. These reeled parts in standard option are shipped with 1,000 units per 7" or 18.0 cm diameter reel. The reels are clear in color and is made of polystyrene plastic (anti-static coated).

Dimensions are in millimeter

Pkg type	A	B	C	d	E	F	P0	P	P1	W
SOT-89-3L	4.85	4.45	1.85	Ø1.50	1.75	5.50	4.00	8.00	2.00	12.00

SOT-89-3L Tape Leader and Trailer

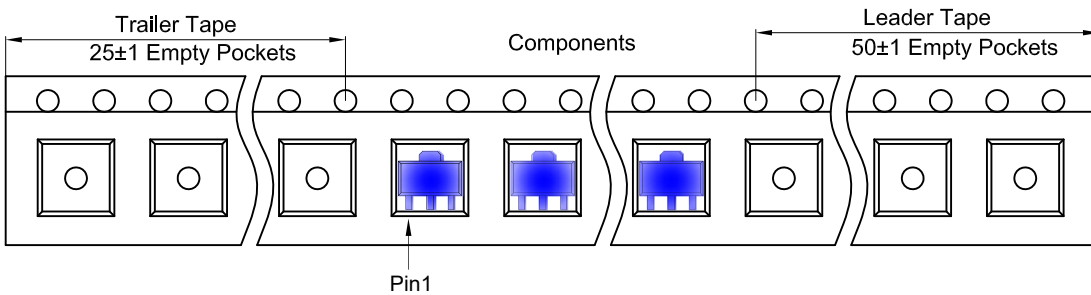

SOT-89-3L Reel

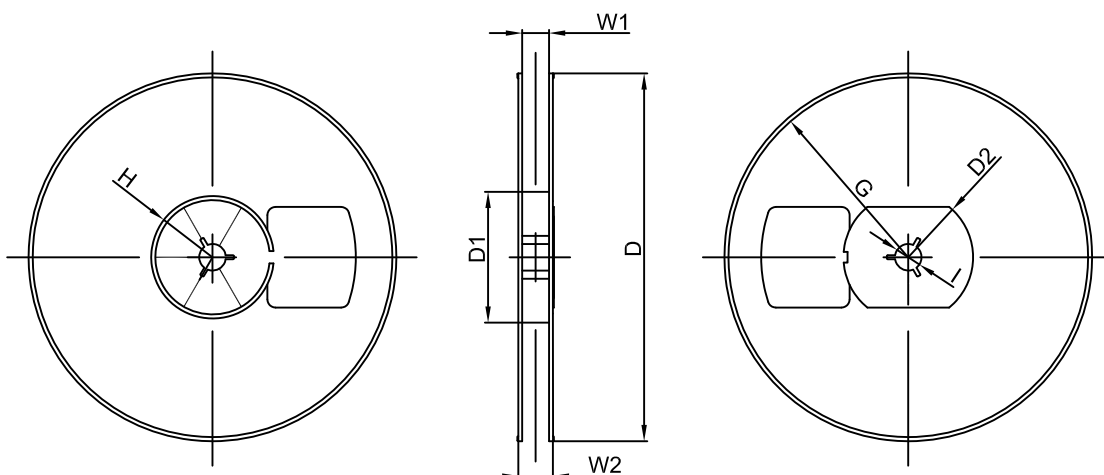

Dimensions are in millimeter

Reel Option	D	D1	D2	G	H	I	W1	W2
7" Dia	Ø180.00	60.00	R32.00	R86.50	R30.00	Ø13.00	13.20	16.50

REEL	Reel Size	Box	Box Size(mm)	Carton	Carton Size(mm)	G.W.(kg)
1000 pcs	7 inch	10,000 pcs	203×203×195	40,000 pcs	438×438×220	

12 Notes and Revision History

12.1 Associated Product Family and Others

To view other products of the same type or IC products of other types, click the official website of JSCJ -- <https://www.jscj-elec.com> for more details.

12.2 Notes

Electrostatic Discharge Caution



This IC may be damaged by ESD. Relevant personnel shall comply with correct installation and use specifications to avoid ESD damage to the IC. If appropriate measures are not taken to prevent ESD damage, the hazards caused by ESD include but are not limited to degradation of integrated circuit performance or complete damage of integrated circuit. For some precision integrated circuits, a very small parameter change may cause the whole device to be inconsistent with its published specifications.

12.3 Revision History

October, 2023: changed from rev - 2.3 to rev - 2.4:

- Page 2, Orderable Information, added the figure of the Naming Conventions;
- Page 2, Orderable Information, simplified customized product information in the table;
- Page 4, Pin Configuration and Marking Information, deleted the Pin Configuration table;
- Page 5, Marking Information, added specific marking information tables;
- Page 6, Recommended Operating Conditions, removed note 4;
- Page 12, Typical Characteristics, removed the figure of the SCP;
- Page 30, Notes, removed the notes of the thermal metric.

April, 2022: changed from rev - 2.2 to rev - 2.3:

- Page 9, Thermal Information, added the thermal resistance $R_{\theta JC}$ to the data sheet.

January, 2022: changed from rev - 2.1 to rev - 2.2:

- Page 9, Thermal Information, the thermal resistance $R_{\theta JA}$ of SOT-89-3L is changed from "220.0" to "160.0", $P_{D Ref}$ is changed from "0.60" to "0.63".

November, 2022: changed from rev - 2.0 to rev - 2.1:

- Page 5 ~ 6, Pin Configuration, added pin diagram corresponding to encapsulation code;
- Page 20, SOT-89-3L Suggested Pad Layout, changed recommended pads.

September, 2022: changed from rev - 1.0 to rev - 2.0:

- Added the information of device "CJ6385AxxT", "CJ6385AxxTA" and "CJ6385AxxTB" to the corresponding position of the data sheet;
- Changed the data sheet layout to JSCJ format.
- Page 2, page 3 and page 4, Orderable Information, deleted the description at the top;
- Page 11, Typical Characteristic, added the Output Temperature Characteristic;
- Page 17, Risk Alert and Precautions, modified as "it is recommended that the input voltage should not exceed 20V";
- Added the Package Information;
- Page 38, DISCLAIMER, deleted the description of "automotive electronics".

June, 2022: released CJ6385 series rev - 1.0.

DISCLAIMER

IMPORTANT NOTICE, PLEASE READ CAREFULLY

The information in this data sheet is intended to describe the operation and characteristics of our products. JSCJ has the right to make any modification, enhancement, improvement, correction or other changes to any content in this data sheet, including but not limited to specification parameters, circuit design and application information, without prior notice.

Any person who purchases or uses JSCJ products for design shall: 1. Select products suitable for circuit application and design; 2. Design, verify and test the rationality of circuit design; 3. Procedures to ensure that the design complies with relevant laws and regulations and the requirements of such laws and regulations. JSCJ makes no warranty or representation as to the accuracy or completeness of the information contained in this data sheet and assumes no responsibility for the application or use of any of the products described in this data sheet.

Without the written consent of JSCJ, this product shall not be used in occasions requiring high quality or high reliability, including but not limited to the following occasions: medical equipment, military facilities and aerospace. JSCJ shall not be responsible for casualties or property losses caused by abnormal use or application of this product.

Official Website: www.jscj-elec.com

Copyright © JIANGSU CHANGJING ELECTRONICS TECHNOLOGY CO., LTD.

X-ON Electronics

Largest Supplier of Electrical and Electronic Components

Click to view similar products for [Linear Voltage Regulators](#) category:

Click to view products by [Changjing Electronics Technology](#) manufacturer:

Other Similar products are found below :

[LV5684PVD-XH](#) [MCDTSA6-2R](#) [L7815ACV-DG](#) [714954EB](#) [ZMR500QFTA](#) [BA033LBSG2-TR](#) [LV5680P-E](#) [L79M05T-E](#) [L78LR05D-MA-E](#) [NCV317MBTG](#) [NTE7227](#) [MP2018GZD-33-P](#) [MP2018GZD-5-P](#) [LV5680NPVC-XH](#) [LT1054CN8](#) [ZTS6538SE](#) [UA78L09CLP](#) [UA78L09CLPR](#) [CAT6221-PPTD-GT3](#) [MC78M09CDTRK](#) [NCV51190MNTAG](#) [78M05](#) [HT7150-1](#) [UM1540DB-18](#) [XC6234H281VR-G](#) [WL2834CA-6/TR](#) [TPL730F33-5TR](#) [TLS850F1TA](#) [V50](#) [TPS549B22RVFR](#) [UM1540DB-33](#) [WL9200P3-50B](#) [WL9100P3-33B](#) [WL9005D4-33](#) [XC6219B152MR](#) [WL2855K33-3/TR](#) [PJ54BM33SE](#) [PJ9500M25SA](#) [MD7218E33PC1](#) [H7533-2PR](#) [SK7812AU](#) [SD1A30](#) [78L33](#) [TP78L33T3](#) [L78L33ACUTR](#) [SK6513ST3A-50](#) [SK6054D4-09](#) [SK6054D4-18](#) [SK6054D4-11](#) [SK6054D4-10](#) [LM79L12F](#)