

CJ75XX

INTRODUCTION

The CJ75XX series are a group of positive voltage regulators manufactured by CMOS technologies with low power consumption and low dropout voltage, which provide large output currents even when the difference of the input-output voltage is small. The CJ75XX series can deliver 250mA output current and allow an input voltage as high as 36V. The series are very suitable for the battery-powered equipments, such as RF applications and other systems requiring a quiet voltage source.

SOT-89-3L

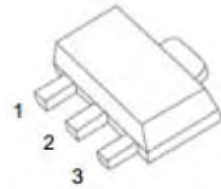

1.GND
2.IN
3.OUT

FEATURES

- Low Quiescent Current: 2 μ A
- Operating Voltage Range: 2.5V~36V
- Output Current: 250mA
- Low Dropout Voltage:
700mV@100mA($V_{OUT}=3.3V$)
- Output Voltage: 2.1~ 12V
- High Accuracy: $\pm 2\%/\pm 1\%$ (Typ.)
- High Power Supply Rejection Ratio:
70dB@1kHz
- Low Output Noise:
27x V_{OUT} μ V_{RMS}(10Hz~100kHz)
- Excellent Line and Load Transient Response
- Built-in Current Limiter,
Short-Circuit Protection
- Over-Temperature Protection
- Stable with Ceramic or Tantalum
Capacitor

APPLICATIONS

- Cordless Phones
- Radio control systems
- Laptop, Palmtops and PDAs
- Single-lens reflex DSC
- PC peripherals with memory
- Wireless Communication Equipments
- Portable Audio Video Equipments
- Car Navigation Systems
- LAN Cards
- Ultra Low Power Microcontrollers

BLOCK DIAGRAM

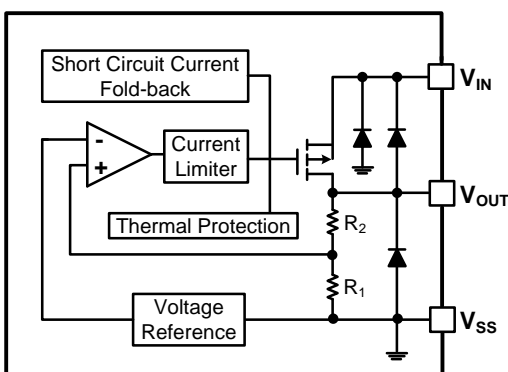

TYPICAL APPLICATION CIRCUIT

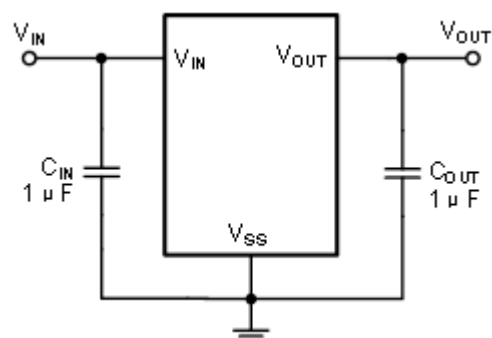

Electrical Characteristics

ABSOLUTE MAXIMUM RATINGS

(Unless otherwise specified, $T_A=25^\circ\text{C}$)

PARAMETER	SYMBOL	RATINGS	UNITS
Input Voltage ⁽²⁾	V_{IN}	-0.3~40	V
Output Voltage ⁽²⁾	V_{OUT}	-0.3~13	V
Power Dissipation	P_D	0.6	W
Operating Ambient Temperature Range	T_A	-40~+85	$^\circ\text{C}$
Operating Junction Temperature Range ⁽³⁾	T_j	-40~+125	$^\circ\text{C}$
Storage Temperature	T_{stg}	-40~+125	$^\circ\text{C}$
Lead Temperature(Soldering, 10 sec)	T_{solder}	260	$^\circ\text{C}$

(1) Stresses beyond those listed under *absolute maximum ratings* may cause permanent damage to the device. These are stress ratings only, and functional operation of the device at these or any other conditions beyond those indicated under *recommended operating conditions* is not implied. Exposure to absolute-maximum-rated conditions for extended periods may affect device reliability.

(2) All voltages are with respect to network ground terminal.

(3) This IC includes over temperature protection that is intended to protect the device during momentary overload. Junction temperature will exceed 125°C when over temperature protection is active. Continuous operation above the specified maximum operating junction temperature may impair device reliability.

RECOMMENDED OPERATING CONDITIONS

PARAMETER	MIN.	NOM.	MAX.	UNITS
Supply voltage at V_{IN}	2.5		36	V
Operating junction temperature range, T_j	-40		125	$^\circ\text{C}$
Operating free air temperature range, T_A	-40		85	$^\circ\text{C}$

ELECTRICAL CHARACTERISTICS

PARAMETER	SYMBOL	CONDITIONS	MIN.	TYP. ⁽⁴⁾	MAX.	UNITS
Input Voltage	V_{IN}		2.5	—	36	V
Output Voltage Range	V_{OUT}		2.1	—	12	V
DC Output Accuracy		$I_{OUT}=10\text{mA}$	-2	—	2	%
			-1	—	1	%
Dropout Voltage	$V_{dif}^{(5)}$	$I_{OUT}=100\text{mA}, V_{OUT}=3.3\text{V}$	—	700	—	mV
Supply Current	I_{SS}	$I_{OUT}=0\text{A}$	—	2	5	μA
Line Regulation	$\frac{\Delta V_{OUT}}{V_{OUT} \times \Delta V_{IN}}$	$I_{OUT}=10\text{mA}$ $V_{OUT}+1\text{V} \leq V_{IN} \leq 36\text{V}$	—	0.01	0.3	%/V
Load Regulation	ΔV_{OUT}	$V_{IN}=V_{OUT}+2\text{V}$, $1\text{mA} \leq I_{OUT} \leq 100\text{mA}$	—	10	—	mV
Temperature Coefficient	$\frac{\Delta V_{OUT}}{V_{OUT} \times \Delta T_A}$	$I_{OUT}=40\text{mA}$, $-40^\circ\text{C} < T_A < 85^\circ\text{C}$	—	50	—	ppm
Output Current Limit	I_{LIM}	$V_{OUT}=0.5 \times V_{OUT(Normal)}$	—	350	—	mA
Short Current	I_{SHORT}	$V_{OUT}=V_{SS}$	—	25	—	mA
Power Supply Rejection Ratio	PSRR	$I_{OUT}=50\text{mA}$	100Hz	—	80	dB
			1kHz	—	70	
			10kHz	—	60	
			100kHz	—	50	

Electrical Characteristics

PARAMETER	SYMBOL	CONDITIONS	MIN.	TYP. ⁽⁴⁾	MAX.	UNITS
Output Noise Voltage	V _{ON}	BW=10Hz to 100kHz	—	27 x V _{OUT}	—	μV _{RMS}
Thermal Shutdown Temperature	T _{SD}	I _{LOAD} = 30mA	—	160	—	°C
Thermal Shutdown Hysteresis	ΔT _{SD}	—	—	20	—	°C

(4) Typical numbers are at 25°C and represent the most likely norm.

(5)V_{diff}: The Difference Of Output Voltage And Input Voltage When Input Voltage Is Decreased Gradually Till Output Voltage Equals To 98% Of V_{OUT} (E).

APPLICATION INFORMATION

Selection of Input/ Output Capacitors

In general, all the capacitors need to be low leakage. Any leakage the capacitors have will reduce efficiency, increase the quiescent current.

A recent trend in the design of portable devices has been to use ceramic capacitors to filter DC-DC converter inputs. Ceramic capacitors are often chosen because of their small size, low equivalent series resistance (ESR) and high RMS current capability. Also, recently, designers have been looking to ceramic capacitors due to shortages of tantalum capacitors.

Unfortunately, using ceramic capacitors for input filtering can cause problems. Applying a voltage step to a ceramic capacitor causes a large current surge that stores energy in the inductances of the power leads. A large voltage spike is created when the stored energy is transferred from these inductances into the ceramic capacitor. These voltage spikes can easily be twice the amplitude of the input voltage step.

Many types of capacitors can be used for input bypassing, however, caution must be exercised when using multilayer ceramic capacitors (MLCC). Because of the self-resonant and high Q characteristics of some types of ceramic capacitors, high voltage transients can be generated under some start-up conditions, such as connecting the LDO input to a live power source. Adding a 3Ω resistor in series with an X5R ceramic capacitor will minimize start-up voltage transients.

The LDO also requires an output capacitor for loop stability. Connect a 1μF tantalum capacitor from OUT to GND close to the pins. For improved transient response, this output capacitor may be ceramic.

MODEL DEFINITION INFORMATION

Model	Output Voltage
CJ7521	2.1V
CJ7523	2.3V
CJ7525	2.5V
CJ7527	2.7V
CJ7530	3.0V
CJ7533	3.3V
CJ7536	3.6V
CJ7540	4.0V
CJ7544	4.4V
CJ7550	5.0V
CJ7560	6.0V
CJ7570	7.0V
CJ7580	8.0V
CJ7590	9.0V
CJ75A0	10.0V
CJ75C0	12.0V

Typical Characteristics

Output Voltage vs. Temperature

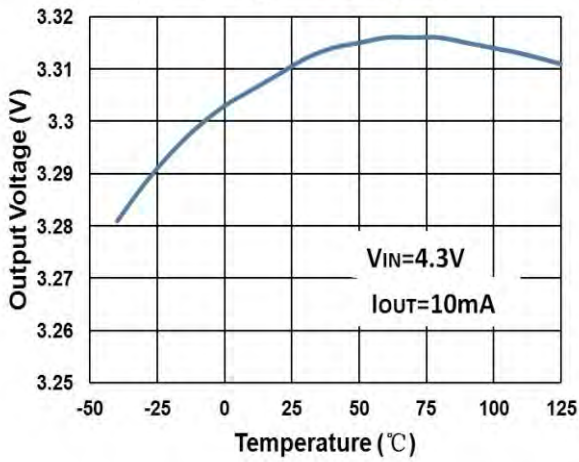

PSRR vs. Frequency

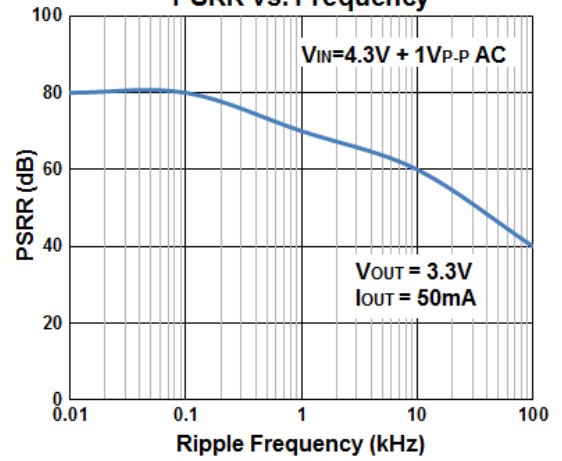

Load Transient Response

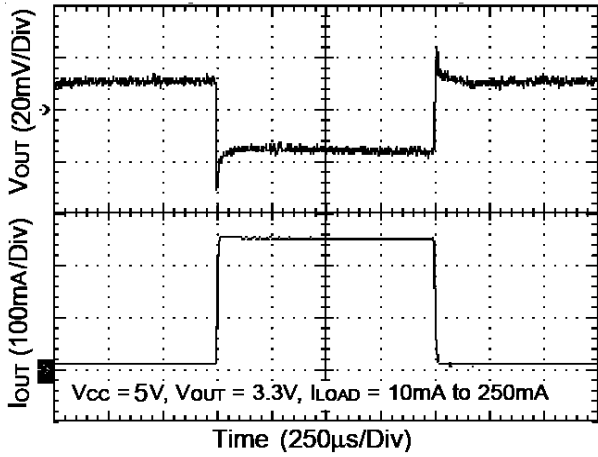

Line Transient Response

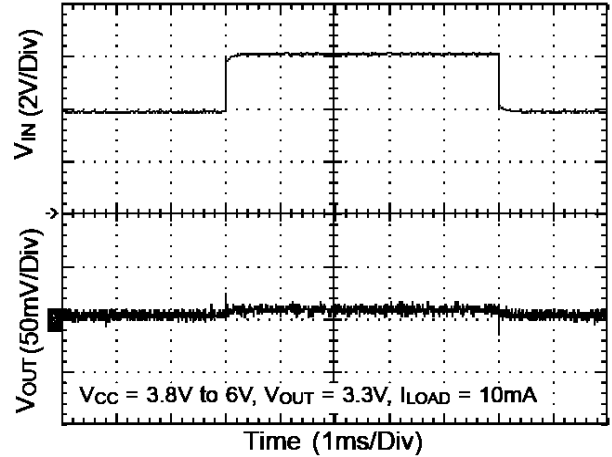

Power Up Response

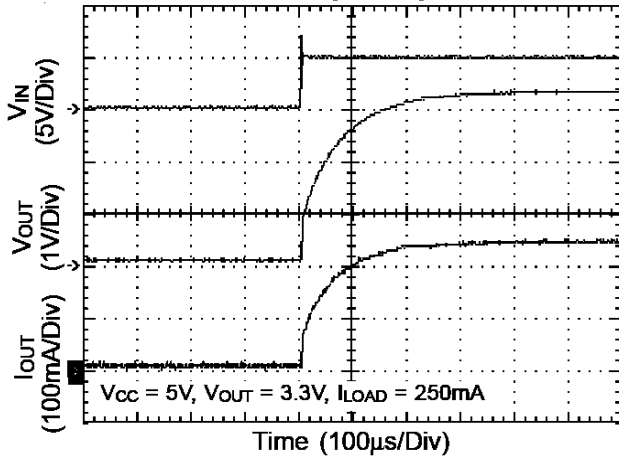

Output Noise 10Hz to 100KHz

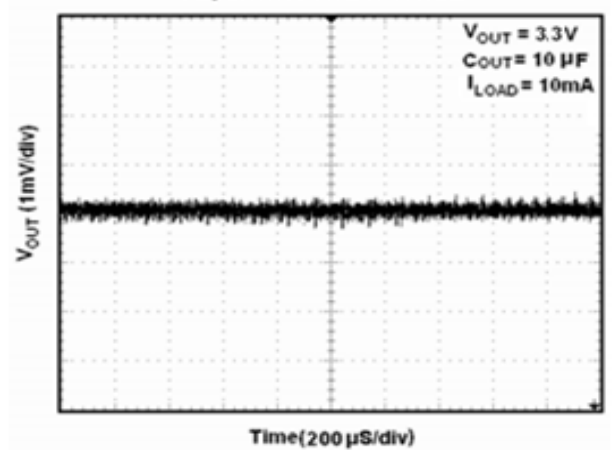

SOT-89-3L Package Outline Dimensions

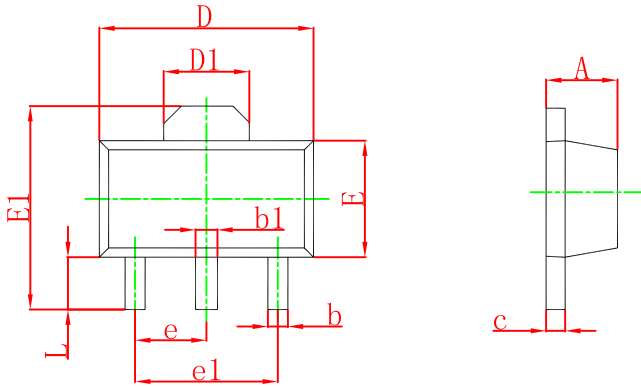

Symbol	Dimensions In Millimeters		Dimensions In Inches	
	Min.	Max.	Min.	Max.
A	1.400	1.600	0.055	0.063
b	0.320	0.520	0.013	0.197
b1	0.400	0.580	0.016	0.023
c	0.350	0.440	0.014	0.017
D	4.400	4.600	0.173	0.181
D1	1.550 REF		0.061 REF	
E	2.300	2.600	0.091	0.102
E1	3.940	4.250	0.155	0.167
e	1.500 TYP		0.060 TYP	
e1	3.000 TYP		0.118 TYP	
L	0.900	1.200	0.035	0.047

SOT-89-3L Suggested Pad Layout

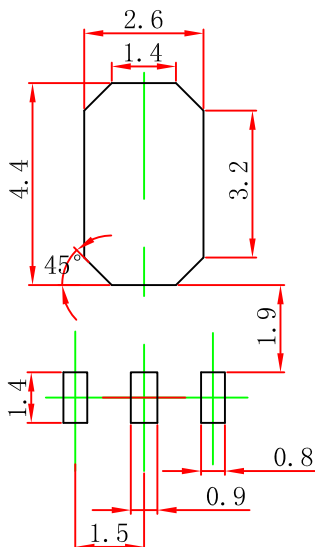

- Note:
1. Controlling dimension: in millimeters.
 2. General tolerance: ± 0.05 mm.
 3. The pad layout is for reference purposes only.

DISCLAIMER

IMPORTANT NOTICE, PLEASE READ CAREFULLY

The information in this data sheet is intended to describe the operation and characteristics of our products. JSCJ has the right to make any modification, enhancement, improvement, correction or other changes to any content in this data sheet, including but not limited to specification parameters, circuit design and application information, without prior notice.

Any person who purchases or uses JSCJ products for design shall: 1. Select products suitable for circuit application and design; 2. Design, verify and test the rationality of circuit design; 3. Procedures to ensure that the design complies with relevant laws and regulations and the requirements of such laws and regulations. JSCJ makes no warranty or representation as to the accuracy or completeness of the information contained in this data sheet and assumes no responsibility for the application or use of any of the products described in this data sheet.

Without the written consent of JSCJ, this product shall not be used in occasions requiring high quality or high reliability, including but not limited to the following occasions: medical equipment, automotive electronics, military facilities and aerospace. JSCJ shall not be responsible for casualties or property losses caused by abnormal use or application of this product.

Official Website: www.jscj-elec.com

Copyright © JIANGSU CHANGJING ELECTRONICS TECHNOLOGY CO., LTD.

X-ON Electronics

Largest Supplier of Electrical and Electronic Components

Click to view similar products for [Linear Voltage Regulators](#) category:

Click to view products by [Changjing Electronics Technology](#) manufacturer:

Other Similar products are found below :

[LV56831P-E](#) [LV5684PVD-XH](#) [MCDTSA6-2R](#) [L7815ACV-DG](#) [PQ3DZ53U](#) [LV56801P-E](#) [TLE42794G](#) [L78L05CZ/1SX](#) [L78LR05DL-MA-E](#) [636416C](#) [714954EB](#) [BA033LBSG2-TR](#) [LV5680P-E](#) [L78M15CV-DG](#) [TLS202B1MBV33HTSA1](#) [L79M05T-E](#) [TLS202A1MBVHTSA1](#) [L78LR05D-MA-E](#) [NCV317MBTG](#) [NTE7227](#) [LV5680NPVC-XH](#) [LT1054CN8](#) [MP2018GZD-5-Z](#) [MP2018GZD-33-Z](#) [MIC5281-3.3YMM](#) [MC78L06BP-AP](#) [TA48LS05F\(TE85L,F\)](#) [TA78L12F\(TE12L,F\)](#) [TC47BR5003ECT](#) [TCR2LN12,LF\(S\)](#) [TCR2LN28,LF\(S\)](#) [TCR2LN30,LF\(S\)](#) [TCR3DF295,LM\(CT\)](#) [TCR3DF40,LM\(CT\)](#) [BA178M20CP-E2](#) [L78M12ABDT](#) [LM7812SX/NOPB](#) [LR645N3-G-P003](#) [LR645N3-G-P013](#) [ZXTR2005P5-13](#) [SCD7812BTG](#) [TCR3DF335,LM\(CT\)](#) [ZXTR2012K-13](#) [TLE42994E V33](#) [ZXTR2008K-13](#) [ZXTR2005K-13](#) [L88R05DL-E](#) [ADP3300ARTZ-2.7RL7](#) [LM120K-15/883](#) [IFX54441LDVXUMA1](#)