

TO-252-2L Plastic-Encapsulate Regulators

CJ78M06 Three-terminal positive voltage regulator

FEATURES

- Maximum output current
 $I_{OM}: 0.5\text{ A}$
- Output voltage
 $V_O: 6\text{ V}$
- Continuous total dissipation
 $P_D: 1.25\text{ W}$ ($T_a = 25\text{ }^\circ\text{C}$)

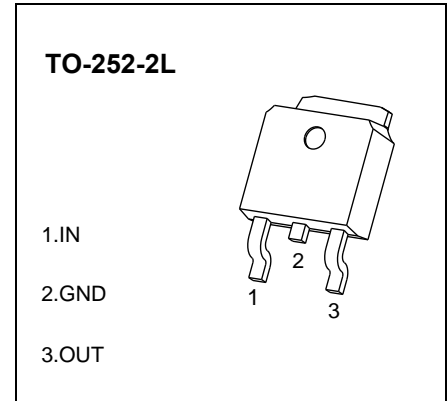

ABSOLUTE MAXIMUM RATINGS (Operating temperature range applies unless otherwise specified)

Parameter	Symbol	Value	Unit
Input Voltage	V_i	35	V
Thermal Resistance from Junction to Ambient	$R_{\theta JA}$	80	$^\circ\text{C/W}$
Operating Junction Temperature Range	T_{OPR}	-40~+125	$^\circ\text{C}$
Storage Temperature Range	T_{STG}	-65~+150	$^\circ\text{C}$

ELECTRICAL CHARACTERISTICS AT SPECIFIED VIRTUAL JUNCTION TEMPERATURE ($V_i=11\text{ V}$, $I_O=350\text{ mA}$, $C_i=0.33\mu\text{F}$, $C_o=0.1\mu\text{F}$, unless otherwise specified)

Parameter	Symbol	Test conditions	Min	Typ	Max	Unit
Output Voltage	V_o	$T_J=25\text{ }^\circ\text{C}$	5.82	6	6.18	V
		$8\text{ V} \leq V_i \leq 21\text{ V}$, $I_o=5\text{ mA}-350\text{ mA}$	5.7	6	6.3	V
Load Regulation	ΔV_o	$I_o=5\text{ mA}-0.5\text{ A}$, $T_J=25\text{ }^\circ\text{C}$		18	120	mV
		$I_o=5\text{ mA}-200\text{ mA}$, $T_J=25\text{ }^\circ\text{C}$		10	60	mV
Line Regulation	ΔV_o	$8\text{ V} \leq V_i \leq 25\text{ V}$, $I_o=200\text{ mA}$, $T_J=25\text{ }^\circ\text{C}$		5	100	mV
		$9\text{ V} \leq V_i \leq 25\text{ V}$, $I_o=200\text{ mA}$, $T_J=25\text{ }^\circ\text{C}$		1.5	50	mV
Quiescent Current	I_q	$T_J=25\text{ }^\circ\text{C}$		4.3	6	mA
Quiescent Current Change	ΔI_q	$9\text{ V} \leq V_i \leq 25\text{ V}$, $I_o=200\text{ mA}$			0.8	mA
	ΔI_q	$5\text{ mA} \leq I_o \leq 350\text{ mA}$			0.5	mA
Output Noise Voltage	V_N	$10\text{ Hz} \leq f \leq 100\text{ kHz}$, $T_J=25\text{ }^\circ\text{C}$		45		$\mu\text{V}/V_o$
Ripple Rejection	RR	$9\text{ V} \leq V_i \leq 19\text{ V}$, $f=120\text{ Hz}$, $I_o=300\text{ mA}$	59	80		dB
Dropout Voltage	V_d	$I_o=350\text{ mA}$, $T_J=25\text{ }^\circ\text{C}$		2		V
Short Circuit Current	I_{sc}	$V_i=11\text{ V}$, $T_J=25\text{ }^\circ\text{C}$		270		mA
Peak Current	I_{pk}	$T_J=25\text{ }^\circ\text{C}$		0.5		A

* Pulse test.

TYPICAL APPLICATION

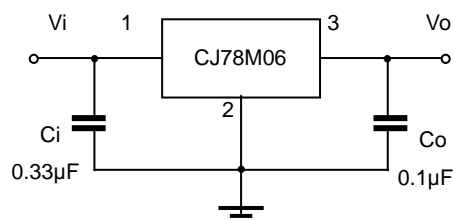

Note: Bypass capacitors are recommended for optimum stability and transient response and should be located as close as possible to the regulators.

Typical Characteristics

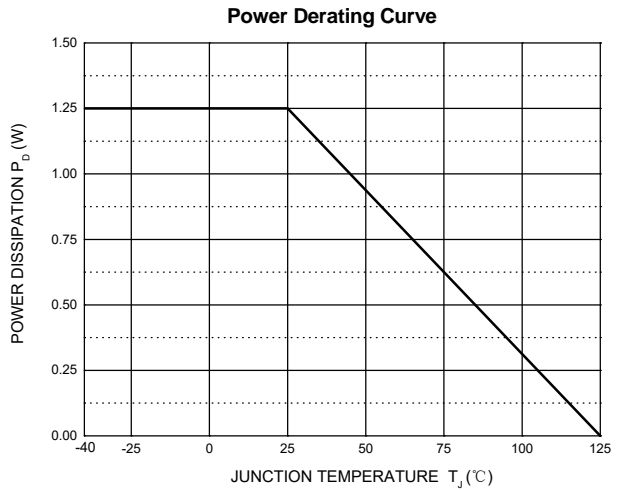
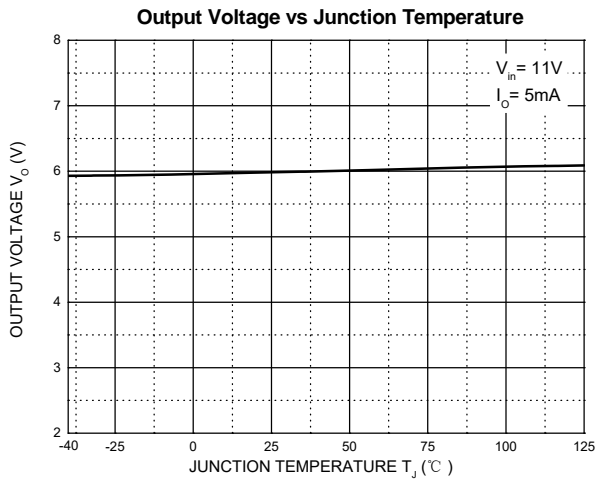
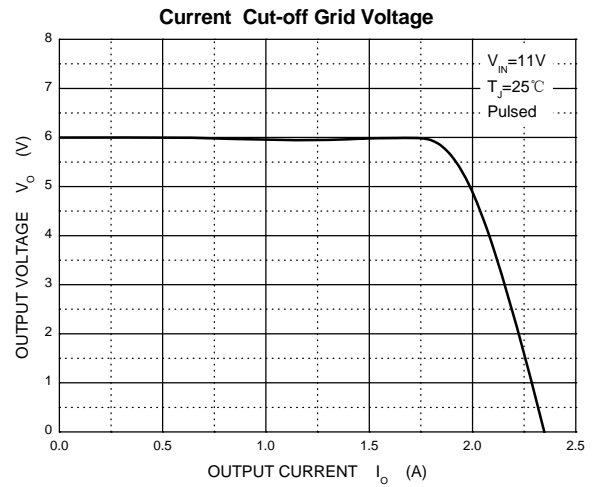
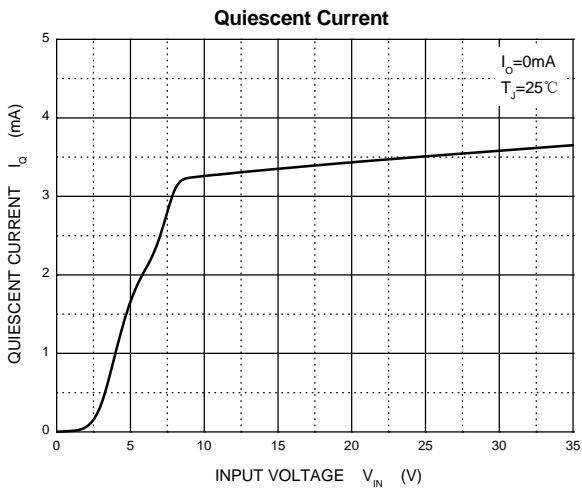
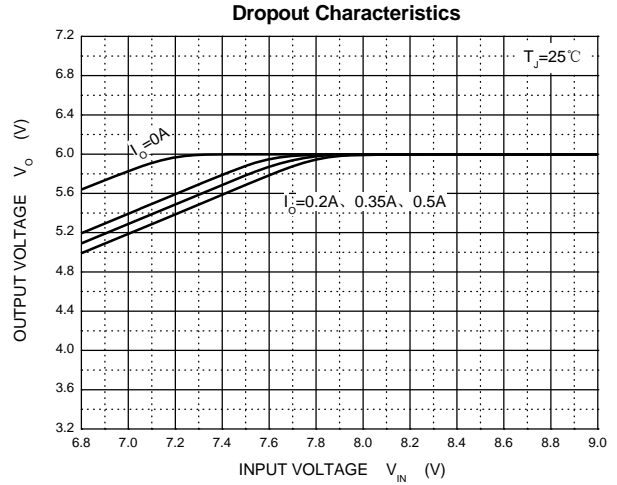
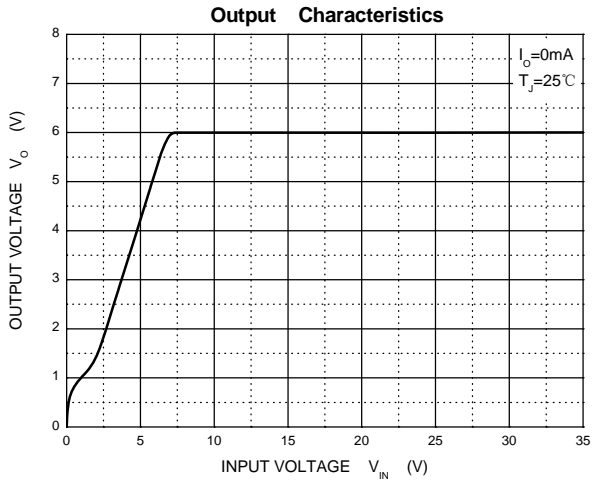

TO-252-2L Package Outline Dimensions

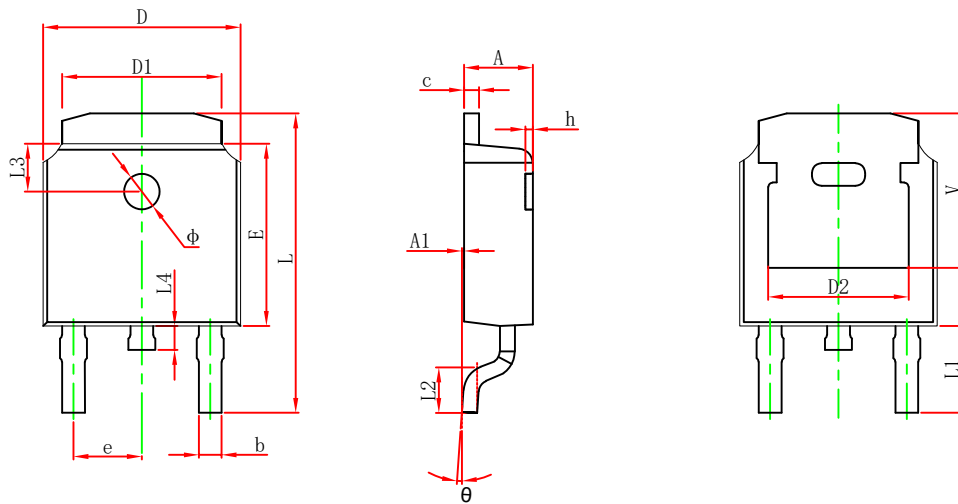

Symbol	Dimensions In Millimeters		Dimensions In Inches	
	Min.	Max.	Min.	Max.
A	2.200	2.400	0.087	0.094
A1	0.000	0.127	0.000	0.005
b	0.635	0.770	0.025	0.030
c	0.460	0.580	0.018	0.023
D	6.500	6.700	0.256	0.264
D1	5.100	5.460	0.201	0.215
D2	4.830 REF.		0.190 REF.	
E	6.000	6.200	0.236	0.244
e	2.186	2.386	0.086	0.094
L	9.712	10.312	0.382	0.406
L1	2.900 REF.		0.114 REF.	
L2	1.400	1.700	0.055	0.067
L3	1.600 REF.		0.063 REF.	
L4	0.600	1.000	0.024	0.039
Phi	1.100	1.300	0.043	0.051
theta	0°	8°	0°	8°
h	0.000	0.300	0.000	0.012
V	5.250 REF.		0.207 REF.	

TO-252-2L Suggested Pad Layout

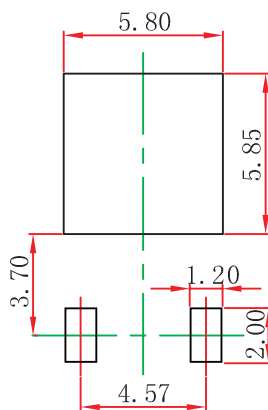

- Note:
1. Controlling dimension: in millimeters.
 2. General tolerance: ± 0.05 mm.
 3. The pad layout is for reference purposes only.

TO-252-2L Tape and Reel

TO-252 Embossed Carrier Tape

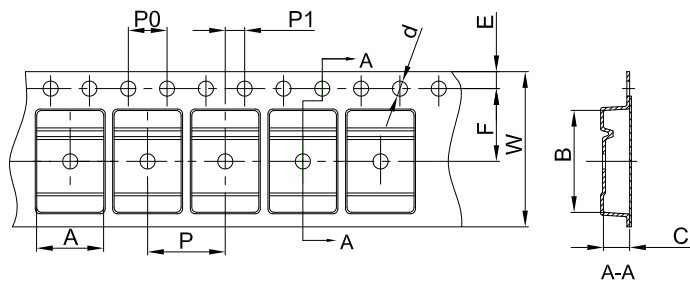

Packaging Description:

TO-252 parts are shipped in tape. The carrier tape is made from a dissipative (carbon filled) polycarbonate resin. The cover tape is a multilayer film (Heat Activated Adhesive in nature) primarily composed of polyester film, adhesive layer, sealant, and anti-static sprayed agent. These reeled parts in standard option are shipped with 25,00 units per 13" or 33.0 cm diameter reel. The reels are clear in color and is made of polystyrene plastic (anti-static coated).

Dimensions are in millimeter										
Pkg type	A	B	C	d	E	F	P0	P	P1	W
TO-252	6.90	10.50	2.70	Ø1.55	1.75	7.50	4.00	8.00	2.00	16.00

TO-252 Tape Leader and Trailer

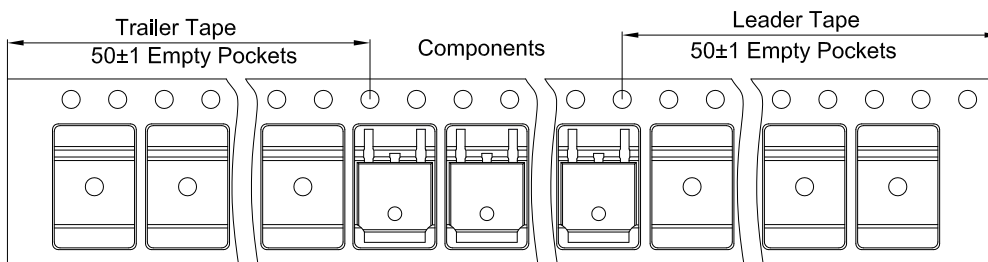

TO-252 Reel

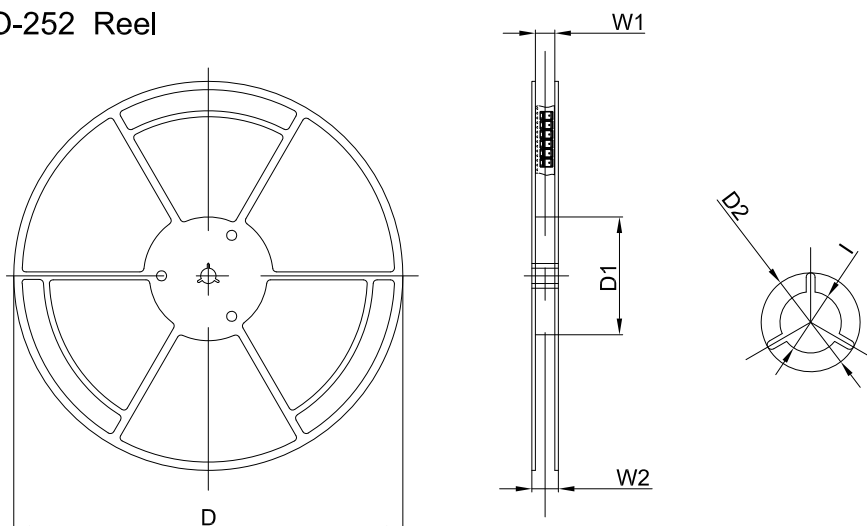

Dimensions are in millimeter						
Reel Option	D	D1	D2	W1	W2	I
13" Dia	330.00	100.00	Ø21.00	16.40	21.00	Ø13.00

REEL	Reel Size	Box	Box Size(mm)	Carton	Carton Size(mm)	G.W.(kg)
2,500 pcs	13inch	2,500 pcs	340×336×29	25,000 pcs	353×346×365	

X-ON Electronics

Largest Supplier of Electrical and Electronic Components

Click to view similar products for [Linear Voltage Regulators](#) category:

Click to view products by [Changjing Electronics Technology](#) manufacturer:

Other Similar products are found below :

[LV56831P-E](#) [LV5684PVD-XH](#) [MCDTSA6-2R](#) [L7815ACV-DG](#) [PQ3DZ53U](#) [LV56801P-E](#) [TLE42794G](#) [L78L05CZ/1SX](#) [L78LR05DL-MA-E](#) [636416C](#) [714954EB](#) [BA033LBSG2-TR](#) [LV5680P-E](#) [L78M15CV-DG](#) [L79M05T-E](#) [TLS202A1MBVHTSA1](#) [L78LR05D-MA-E](#) [NCV317MBTG](#) [NTE7227](#) [LV5680NPVC-XH](#) [LT1054CN8](#) [MP2018GZD-5-Z](#) [MP2018GZD-33-Z](#) [MIC5281-3.3YMM](#) [MC78L06BP-AP](#) [TA48LS05F\(TE85L,F\)](#) [TA78L12F\(TE12L,F\)](#) [TC47BR5003ECT](#) [TCR2LN12,LF\(S](#) [TCR2LN28,LF\(S](#) [TCR2LN30,LF\(S](#) [TCR3DF295,LM\(CT](#) [TCR3DF40,LM\(CT](#) [BA178M20CP-E2](#) [L78M12ABDT](#) [LM7812SX/NOPB](#) [LR645N3-G-P003](#) [LR645N3-G-P013](#) [ZXTR2005P5-13](#) [SCD7812BTG](#) [TCR3DF335,LM\(CT](#) [ZXTR2012K-13](#) [TLE42994E V33](#) [ZXTR2008K-13](#) [ZXTR2005K-13](#) [L88R05DL-E](#) [ADP3300ARTZ-2.7RL7](#) [LM120K-15/883](#) [IFX54441LDVXUMA1](#) [LM317D2T-TR](#)