

TO-220-3L Plastic-Encapsulate Transistors

KTC2026 TRANSISTOR (NPN)

FEATURES

- Low Saturation Voltage
- General Purpose Applications

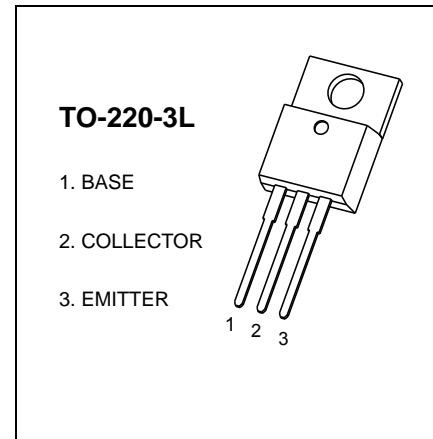

MARKING

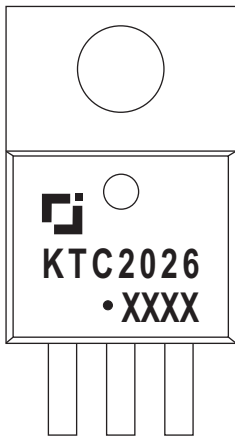

KTC2026=Device code
Solid dot=Green moldinn compound device,
if none,the normal device
XXXX=Code

Equivalent Circuit

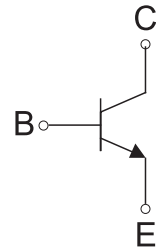

MAXIMUM RATINGS (T_a=25°C unless otherwise noted)

Symbol	Parameter	Value	Unit
V _{CBO}	Collector-Base Voltage	60	V
V _{CEO}	Collector-Emitter Voltage	60	V
V _{EBO}	Emitter-Base Voltage	7	V
I _C	Collector Current	3	A
P _C	Collector Power Dissipation	2	W
R _{θJA}	Thermal Resistance From Junction To Ambient	63	°C/W
T _j , T _{stg}	Operation Junction and Storage Temperature Range	-55~+150	°C

ELECTRICAL CHARACTERISTICS (T_a=25°C unless otherwise specified)

Parameter

	Symbol	Test conditions	Min	Typ	Max	Unit
Collector-base breakdown voltage	V _{(BR)CBO}	I _C =100μA, I _E =0	60			V
Collector-emitter breakdown voltage	V _{(BR)CEO}	I _C =50mA, I _B =0	60			V
Collector-base breakdown voltage	V_{(BR)EBO}	I_E=100μA, I_C=0	7			V
Emitter cut-off current	I _{CBO}	V _{CB} =60V, I _E =0			100	μA
DC current gain	I _{EBO}	V _{EB} =7V, I _C =0			100	μA
	h _{FE}	V _{CE} =5V, I _C =0.5A	100		300	
Collector-emitter saturation voltage	V _{CE(sat)}	I _C =2A, I _B =0.2A			1	V
Base-emitter voltage	V _{BE}	V _{CE} =5V, I _C =0.5A			1	V
Collector output capacitance	C _{ob}	V _{CB} =10V, I _E =0, f=1MHz		35		pF
Transition frequency	f _T	V _{CE} =5V, I _C =0.5A		30		MHz

CLASSIFICATION OF h_{FE}

RANK	Y	GR
RANGE	100-200	150-300

Typical Characteristics

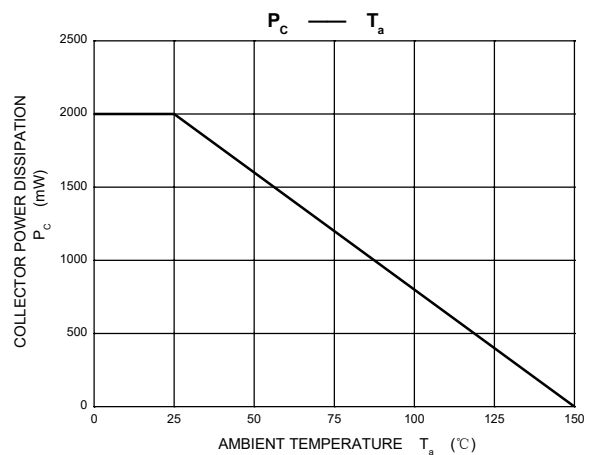
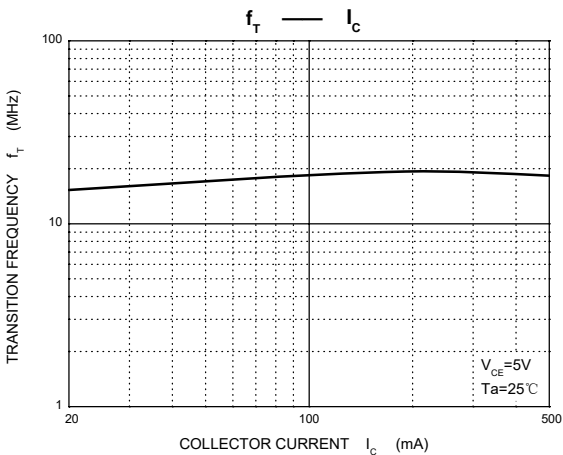
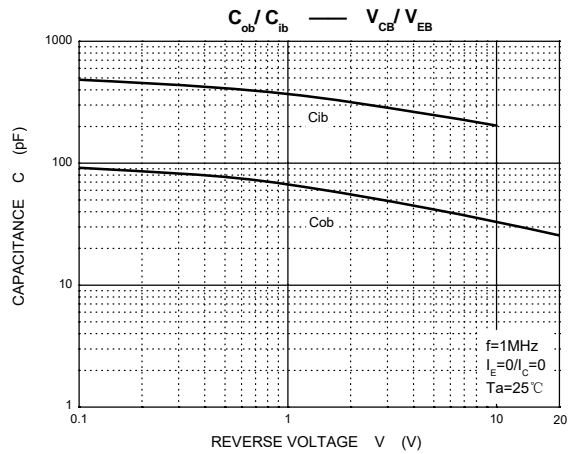
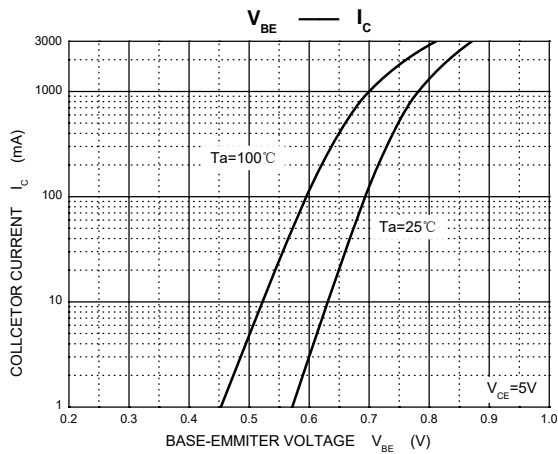
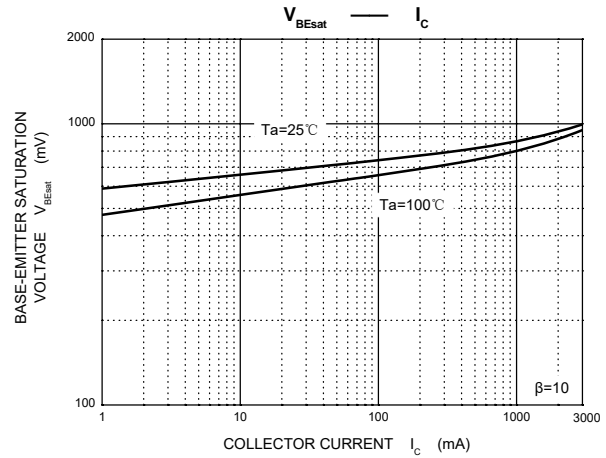
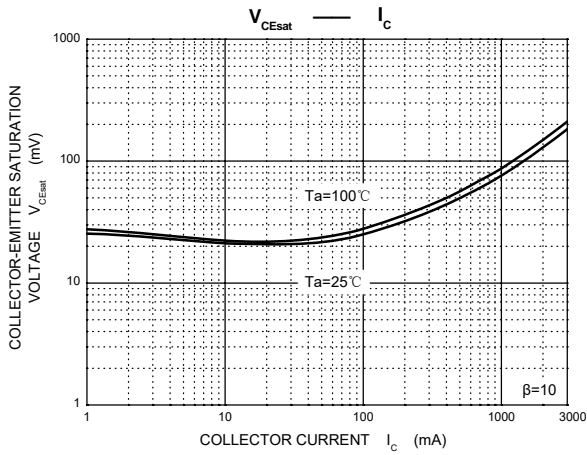
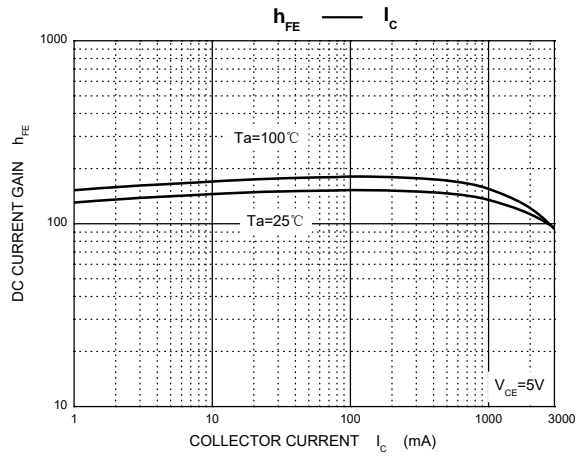
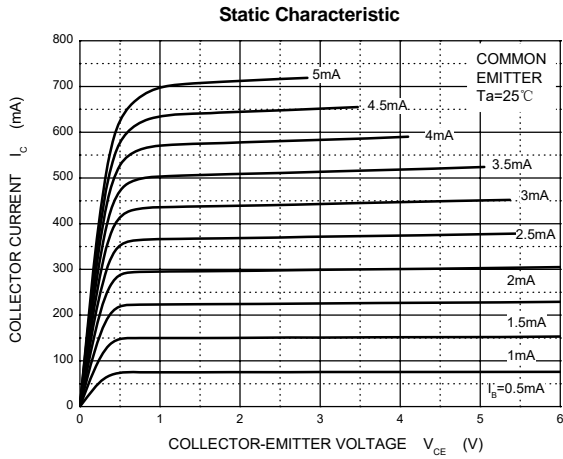

TO-220-3L Package Outline Dimensions

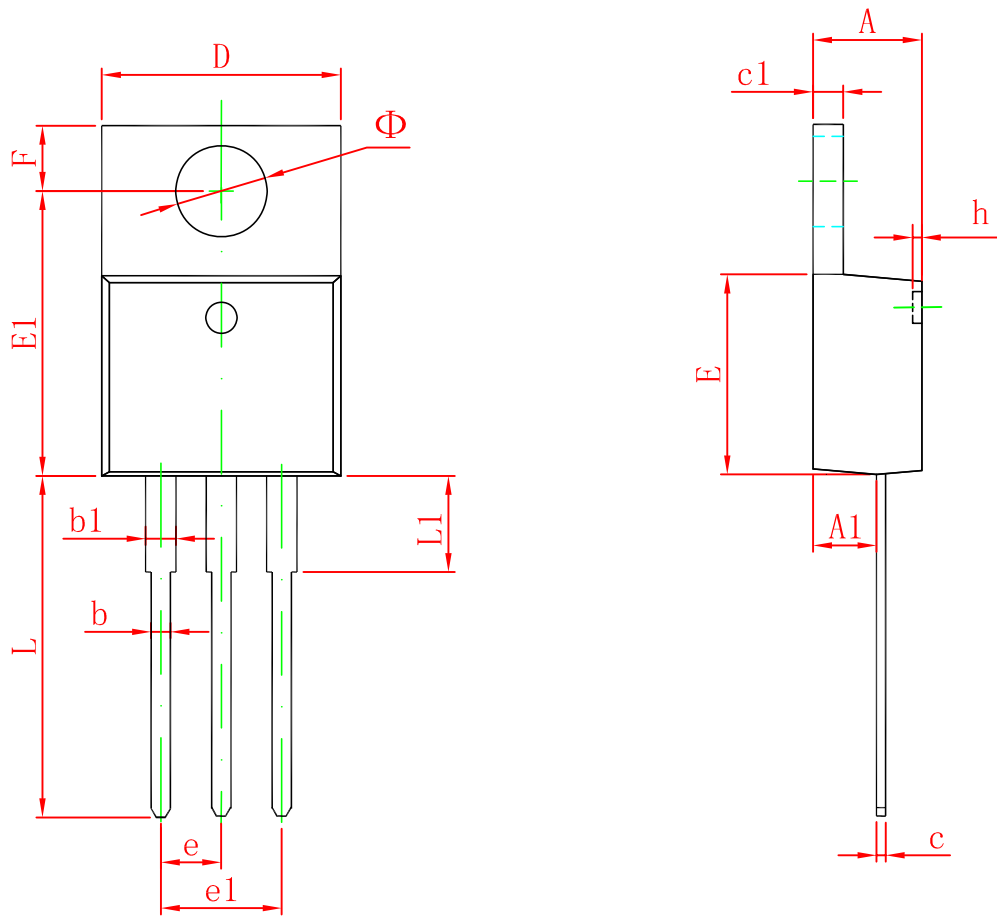

Symbol	Dimensions In Millimeters		Dimensions In Inches	
	Min	Max	Min	Max
A	4.470	4.670	0.176	0.184
A1	2.520	2.820	0.099	0.111
b	0.710	0.910	0.028	0.036
b1	1.170	1.370	0.046	0.054
c	0.310	0.530	0.012	0.021
c1	1.170	1.370	0.046	0.054
D	10.010	10.310	0.394	0.406
E	8.500	8.900	0.335	0.350
E1	12.060	12.460	0.475	0.491
e	2.540 TYP		0.100 TYP	
e1	4.980	5.180	0.196	0.204
F	2.590	2.890	0.102	0.114
h	0.000	0.300	0.000	0.012
L	13.400	13.800	0.528	0.543
L1	3.560	3.960	0.140	0.156
Φ	3.735	3.935	0.147	0.155

X-ON Electronics

Largest Supplier of Electrical and Electronic Components

Click to view similar products for [Bipolar Transistors - BJT category](#):

Click to view products by [Changjing Electronics Technology manufacturer](#):

Other Similar products are found below :

[BC559C](#) [MCH4017-TL-H](#) [MMBT-2369-TR](#) [BC546/116](#) [NJVMJD148T4G](#) [NTE16](#) [NTE195A](#) [IMX9T110](#) [2N4401-A](#) [2N6728](#) [2SA1419T-TD-H](#) [2SB1204S-TL-E](#) [2SC5488A-TL-H](#) [FMC5AT148](#) [2N2369ADCSM](#) [2N2907A](#) [2N3904-NS](#) [2N5769](#) [2SC4618TLN](#) [CPH6501-TL-E](#) [US6T6TR](#) [BAX18/A52R](#) [BC556/112](#) [IMZ2AT108](#) [MMST8098T146](#) [MCH6102-TL-E](#) [BC846B-13-F](#) [2N3879](#) [30A02MH-TL-E](#) [NTE13](#) [NTE282](#) [NTE323](#) [NTE350](#) [NTE81](#) [JANTX2N2920L](#) [JANSR2N2907AUB](#) [CMLT3946EG TR](#) [SNSS40600CF8T1G](#) [CMLT3906EG TR](#) [GRP-DATA-JANS2N2907AUB](#) [GRP-DATA-JANS2N2222AUA](#) [MMDT3946FL3-7](#) [2N4240](#) [JANS2N3019](#) [MSB30KH-13](#) [2N2221AUB](#) [2SD1815T-TL-E](#) [2N6678](#) [2N2907Ae4](#) [JAN2N3507](#)