

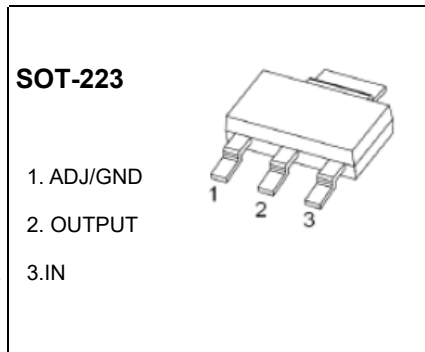

SCJT1117B-XXX-A

FEATURES

- Low Dropout Voltage: 1.3V(typ.) at 1A Output Current
- Trimmed Current Limit
- On-Chip Thermal Shutdown
- Three-Terminal Adjustable or Fixed 1.2V, 1.5V, 1.8V, 2.5V, 3.3V, 5V
- Operation Junction Temperature: -20°C to 125°C



GENERAL DESCRIPTION

The SCJT1117B-XXX-A is a series of low dropout three-terminal regulators with a dropout of 1.3V(typ.) at 1A output current.

The SCJT1117B-XXX-A series provides current limiting and thermal shutdown. Its circuit includes a trimmed bandgap reference to assure output voltage accuracy to be within 2%. Current limit is trimmed to ensure specified. Output current and controlled short-circuit current. On-chip thermal shutdown provides protection against any combination of overload and ambient temperature that would create excessive junction temperature.

The SCJT1117B-XXX-A has an adjustable version, that can provide the output voltage from 1.25V to 12V with only 2 external resistors.

APPLICATIONS

- PC Motherboard
- LCD Monitor
- Graphic Card
- DVD-Video Player
- NIC/Switch
- Telecom Modem
- ADSL Modem
- Printer and Other Peripheral Equipment

MARKING

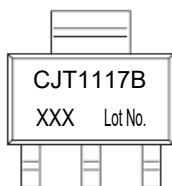

CJT1117B = Device code
XXX: output voltage

MAXIMUM RATINGS

ORDERING INFORMATION

Package	Operating Junction Temperature Range	Part NO.
SOT-223	-20 to 125°C	SCJT1117B-ADJ-A
		SCJT1117B-1.2-A
		SCJT1117B-1.5-A
		SCJT1117B-1.8-A
		SCJT1117B-2.5-A
		SCJT1117B-3.3-A
		SCJT1117B-5.0-A

ABSOLUTE MAXIMUM RATINGS ($T_a=25^\circ\text{C}$ unless otherwise noted)

Parameter	Symbol	Value	Unit
Input Voltage	V_i	20	V
Thermal Resistance from Junction to Ambient	$R_{\theta JA}$	100	$^\circ\text{C}/\text{W}$
Operating Ambient Temperature	T_A	-40~+85	$^\circ\text{C}$
Operating Junction Temperature	T_j	-40~+150	$^\circ\text{C}$
Storage Temperature	T_{stg}	-40~+150	$^\circ\text{C}$
Lead Temperature (Soldering, 10s)	T_L	260	$^\circ\text{C}$
ESD Rating	Human Body Model, HBM	8	kV

Note: Stresses greater than those listed under "Absolute Maximum Ratings" may cause permanent damage to the device. These are stress ratings only, and functional of the device at these or any other conditions beyond those indicated under "Recommended Operating Conditions" is not implied. Exposure to "Absolute Maximum Ratings" for extended periods may affect device reliability.

RECOMMENDED OPERATING CONDITIONS

Parameter	Symbol	Value	Unit
Input Voltage	V_i	15	V
Operating Junction Temperature	T_j	-20~+125	$^\circ\text{C}$

ELECTRICAL CHARACTERISTICS

$T_J=25^{\circ}\text{C}$ unless otherwise specified.

Parameter	Symbol	Part NO.	Test conditions	Min	Typ	Max	Unit
Reference Voltage	V_{IROC}	SCJT1117B-ADJ-A	$I_{OUT}=10\text{mA}$, $V_{IN}=3.25\text{V}$	1.225	1.25	1.275	V
			$10\text{mA}\leq I_{OUT}\leq 1\text{A}$, $2.75\text{V}\leq V_{IN}-V_{OUT}\leq 12\text{V}$	1.219	1.25	1.281	
Output Voltage	V_O	SCJT1117B-1.2-A	$I_{OUT}=10\text{mA}$, $V_{IN}=3.2\text{V}$	1.176	1.2	1.224	V
			$10\text{mA}\leq I_{OUT}\leq 1\text{A}$, $2.7\text{V}\leq V_{IN}\leq 12\text{V}$	1.170	1.2	1.230	
		SCJT1117B-1.5-A	$I_{OUT}=10\text{mA}$, $V_{IN}=3.5\text{V}$	1.470	1.5	1.530	
			$10\text{mA}\leq I_{OUT}\leq 1\text{A}$, $3\text{V}\leq V_{IN}\leq 12\text{V}$	1.463	1.5	1.537	
		SCJT1117B-1.8-A	$I_{OUT}=10\text{mA}$, $V_{IN}=3.8\text{V}$	1.764	1.8	1.836	
			$10\text{mA}\leq I_{OUT}\leq 1\text{A}$, $3.3\text{V}\leq V_{IN}\leq 12\text{V}$	1.755	1.8	1.845	
		SCJT1117B-2.5-A	$I_{OUT}=10\text{mA}$, $V_{IN}=4.5\text{V}$	2.450	2.5	2.550	
			$10\text{mA}\leq I_{OUT}\leq 1\text{A}$, $4\text{V}\leq V_{IN}\leq 12\text{V}$	2.438	2.5	2.562	
		SCJT1117B-3.3-A	$I_{OUT}=10\text{mA}$, $V_{IN}=5.3\text{V}$	3.234	3.3	3.366	
			$10\text{mA}\leq I_{OUT}\leq 1\text{A}$, $4.8\text{V}\leq V_{IN}\leq 12\text{V}$	3.218	3.3	3.382	
		SCJT1117B-5.0-A	$I_{OUT}=10\text{mA}$, $V_{IN}=7.0\text{V}$	4.900	5.0	5.100	
			$10\text{mA}\leq I_{OUT}\leq 1\text{A}$, $6.5\text{V}\leq V_{IN}\leq 12\text{V}$	4.875	5.0	5.125	
Line Regulation	LNR	SCJT1117B-ADJ-A	$I_{OUT}=10\text{mA}$, $1.5\text{V}\leq V_{IN}-V_{OUT}\leq 10.75\text{V}$		0.03	0.2	%V
		SCJT1117B-1.2-A	$I_{OUT}=10\text{mA}$, $1.5\text{V}\leq V_{IN}-V_{OUT}\leq 8.8\text{V}$		0.03	0.2	
		SCJT1117B-1.5-A	$I_{OUT}=10\text{mA}$, $1.5\text{V}\leq V_{IN}-V_{OUT}\leq 8.5\text{V}$		0.03	0.2	
		SCJT1117B-1.8-A	$I_{OUT}=10\text{mA}$, $1.5\text{V}\leq V_{IN}-V_{OUT}\leq 10.2\text{V}$		0.03	0.2	
		SCJT1117B-2.5-A	$I_{OUT}=10\text{mA}$, $1.5\text{V}\leq V_{IN}-V_{OUT}\leq 9.5\text{V}$		0.03	0.2	
		SCJT1117B-3.3-A	$I_{OUT}=10\text{mA}$, $1.5\text{V}\leq V_{IN}-V_{OUT}\leq 8.7\text{V}$		0.03	0.2	
		SCJT1117B-5.0-A	$I_{OUT}=10\text{mA}$, $1.5\text{V}\leq V_{IN}-V_{OUT}\leq 7\text{V}$		0.03	0.2	
Load Regulation	LDR	SCJT1117B-ADJ-A	$V_{IN}-V_{OUT}=1.5\text{V}$, $10\text{mA}\leq I_{OUT}\leq 1\text{A}$		2	8	mV
		SCJT1117B-1.2-A			2	8	
		SCJT1117B-1.5-A			2	8	
		SCJT1117B-1.8-A			3	12	
		SCJT1117B-2.5-A			4	16	
		SCJT1117B-3.3-A			6	24	
		SCJT1117B-5.0-A			9	36	
Dropout Voltage	V_D		$I_{OUT}=1\text{A}$		1.3	1.5	V
Adjust Pin Current	I_{Adj}	SCJT1117B-ADJ-A	$V_{IN}=5\text{V}$, $I_{OUT}=10\text{mA}$		55	120	μA
			$V_{IN}=5\text{V}$, $I_{OUT}=1\text{A}$		55	120	μA
I_{Adj} change	I_{change}	SCJT1117B-ADJ-A	$V_{IN}=5\text{V}$, $10\text{mA}\leq I_{OUT}\leq 1\text{A}$		0.2	10	μA
Minimum Load Current	I_L	SCJT1117B-ADJ-A			2	10	mA
Quiescent Current	I_q	SCJT1117B-1.2-A	$V_{IN}=10\text{V}$		2	5	mA
		SCJT1117B-1.5-A	$V_{IN}=10\text{V}$		2	5	mA
		SCJT1117B-1.8-A	$V_{IN}=12\text{V}$		2	5	mA
		SCJT1117B-2.5-A	$V_{IN}=12\text{V}$		2	5	mA
		SCJT1117B-3.3-A	$V_{IN}=12\text{V}$		2	5	mA
		SCJT1117B-5.0-A	$V_{IN}=12\text{V}$		2	5	mA
Ripple Rejection	RR		$f=1\text{kHz}$, $C_{IN}=10\mu\text{F}/25\text{V}$, $C_{OUT}=10\mu\text{F}/25\text{V}$, $V_{IN}-V_{OUT}=2\text{V}$, $I_{OUT}=10\text{mA}$		60		dB

FUNCTIONAL BLOCK and TYPICAL APPLICATION

FUNCTIONAL BLOCK DIAGRAM

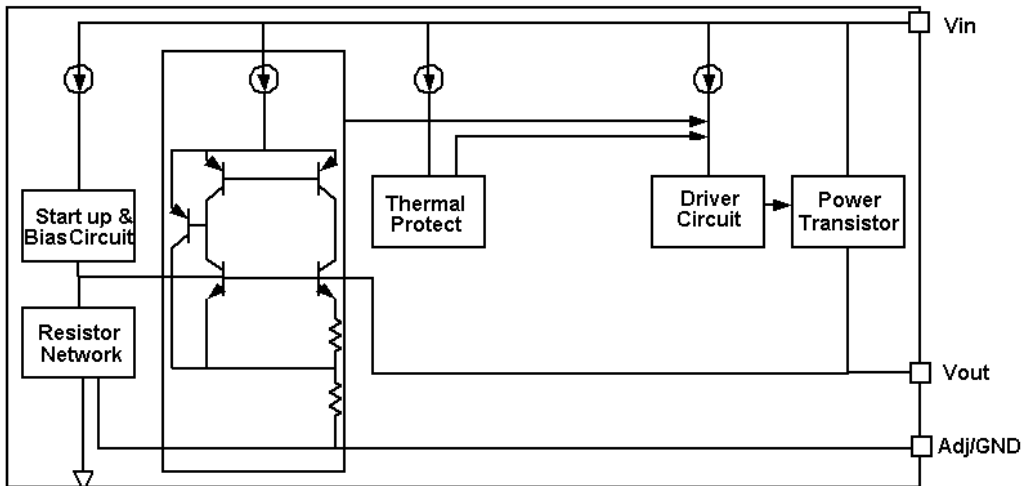

DETAILED DESCRIPTION

SCJT1117B-XXX-A is a series of low dropout voltage, three terminal regulators. Its application circuit is very simple: the fixed version only needs two capacitors and the adjustable version only needs two resistors and two capacitors to work. It is composed of some modules including start-up circuit, bias circuit, bandgap, thermal shutdown, power transistors and its driver circuit and so on.

The thermal shut down modules can assure chip and its application system working safety when the junction temperature is larger than 140°C.

The bandgap module provides stable reference voltage, whose temperature coefficient is compensated by careful design considerations. The temperature coefficient is under 100 ppm/°C. And the accuracy of output voltage is guaranteed by trimming technique.

TYPICAL APPLICATION

Fixed Output Voltage Version

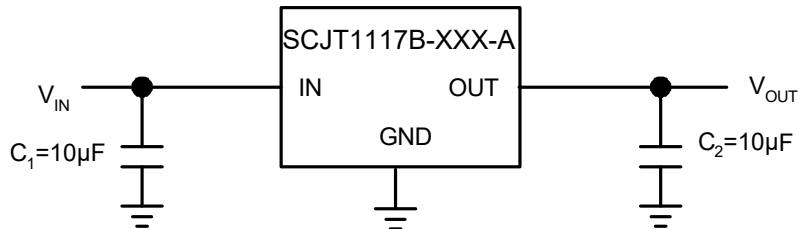

- 1) Recommend using 10uF tan capacitor as bypass capacitor (C1) for all application circuit.
- 2) Recommend using 10uF tan capacitor to assure circuit stability.

TYPICAL APPLICATION

Adjustable Output Voltage Version

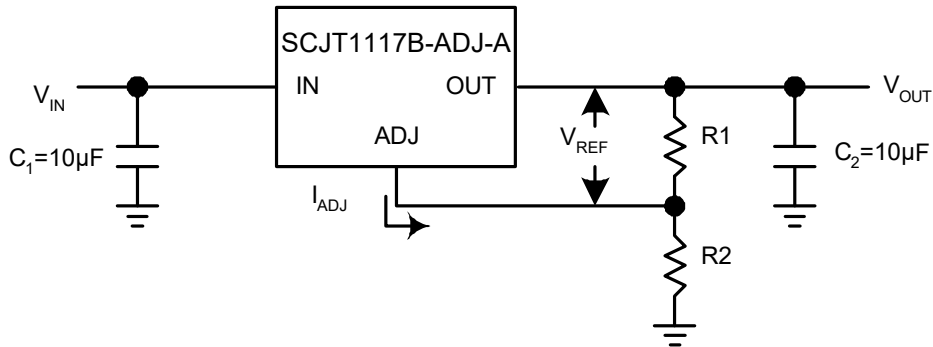

$$V_{OUT} = V_{REF} \times (1 + R2/R1) + I_{ADJ} \times R2$$

The output voltage of adjustable version follows the equation: $V_{out} = 1.25 \times (1 + R2/R1) + I_{Adj} \times R2$. We can ignore I_{Adj} because I_{Adj} (about 50µA) is much less than the current of $R1$ (about 2~10mA).

1) To meet the minimum load current (>10mA) requirement, $R1$ is recommended to be 125ohm or lower. As SCJT1117B-ADJ-A can keep itself stable at load current about 2mA, $R1$ is not allowed to be higher than 625ohm.

2) Using a bypass capacitor (C_{ADJ}) between the ADJ pin and ground can improve ripple rejection. This bypass capacitor prevents ripple from being amplified as the output voltage is increased. The impedance of C_{ADJ} should be less than $R1$ to prevent ripple from being amplified. As $R1$ is normally in the range of 100Ω~500Ω, the value of C_{ADJ} should satisfy this equation: $1/(2\pi \times f_{ripple} \times C_{ADJ}) < R1$.

THERMAL CONSIDERATION

We have to take heat dissipation into great consideration when output current or differential voltage of input and output voltage is large. Because in such cases, the power dissipation consumed by SCJT1117B-ADJ-A is very large. SCJT1117B-ADJ-A series uses SOT-223 package type and its thermal resistance is about 20°C/W. And the copper area of application board can affect the total thermal resistance. If copper area is 5cm*5cm (two sides), the resistance is about 30°C/W. So the total thermal resistance is about 20°C/W+30°C/W. We can decrease total thermal resistance by increasing copper area in application board. When there is no good heat dissipation copper are in PCB, the total thermal resistance will be as high as 120°C/W, then the power dissipation of SCJT1117B-ADJ-A could allow on itself is less than 1W. And furthermore, SCJT1117B-ADJ-A will work at junction temperature higher than 125°C under such condition and no lifetime is guaranteed.

TYPICAL PERFORMANCE CHARACTERISTICS

$T_A=25^{\circ}\text{C}$, unless otherwise noted.

Line regulation

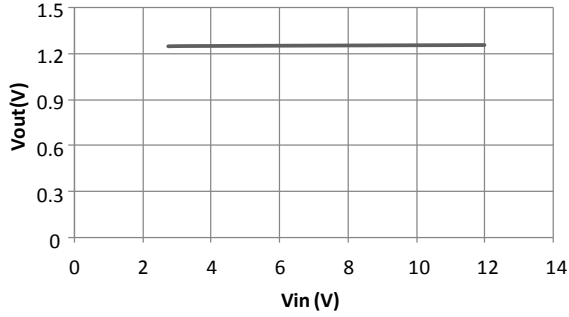

Load regulation

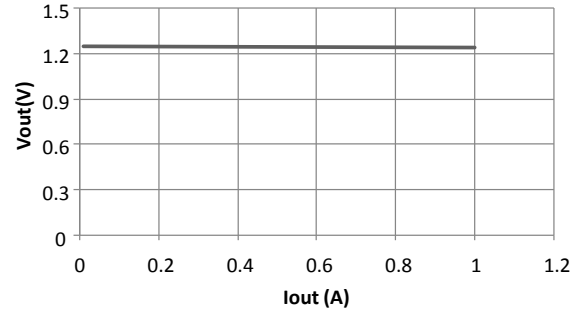

Dropout Voltage (ADJ Except)

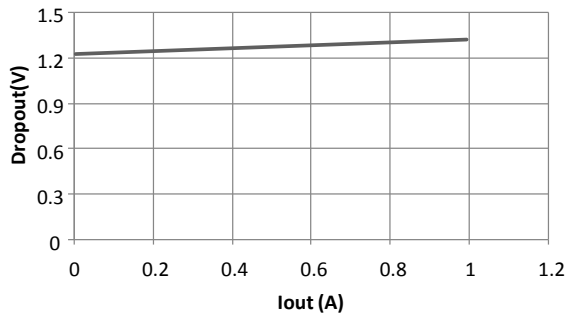

Dropout Voltage (ADJ Only)

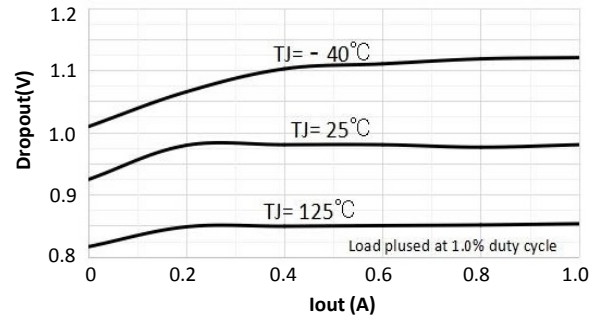

Thermal performance with OTP

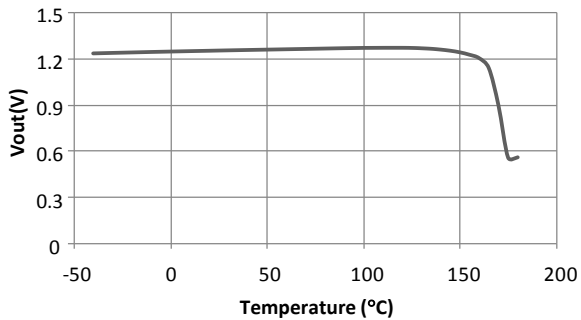

TYPICAL PERFORMANCE CHARACTERISTICS

$T_A=25^{\circ}\text{C}$, unless otherwise noted.

Power ON / OFF

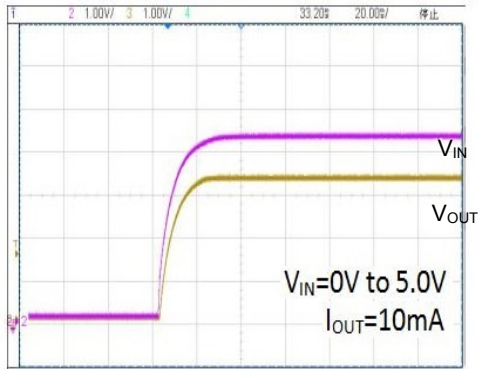

Power ON / OFF

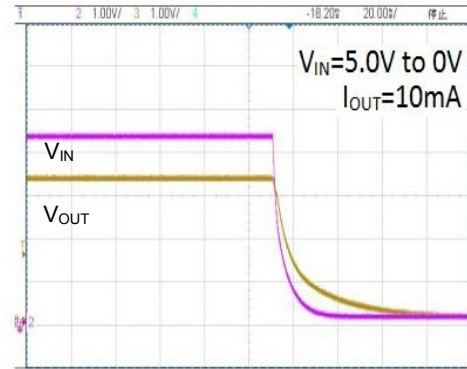

Load Transient Response

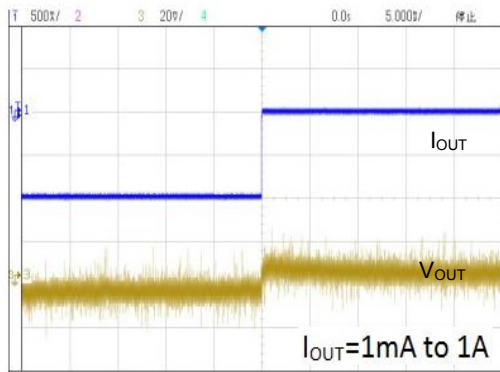

Load Transient Response

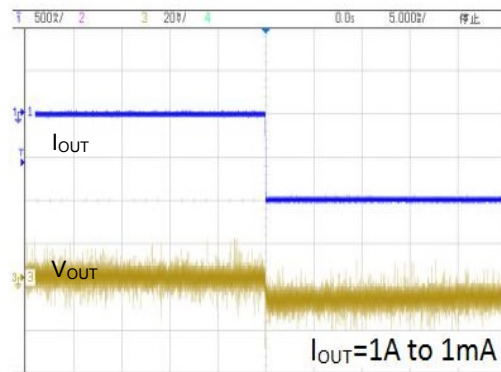

SOT-223 Package Outline Dimensions

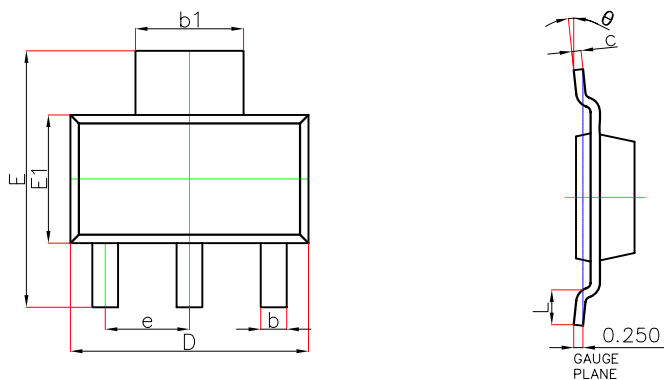

Symbol	Dimensions In Millimeters		Dimensions In Inches	
	Min.	Max.	Min.	Max.
A	—	1.800	—	0.071
A1	0.020	0.100	0.001	0.004
A2	1.500	1.700	0.059	0.067
b	0.660	0.840	0.026	0.033
b1	2.900	3.100	0.114	0.122
c	0.230	0.350	0.009	0.014
D	6.300	6.700	0.248	0.264
E	6.700	7.300	0.264	0.287
E1	3.300	3.700	0.130	0.146
e	2.300(BSC)		0.091(BSC)	
L	0.750	—	0.030	—
θ	0°	10°	0°	10°

SOT-223 Suggested Pad Layout

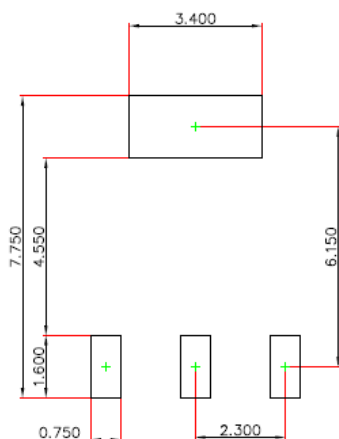

Note:

1. Controlling dimension: in millimeters.
2. General tolerance: ± 0.050 mm.
3. The pad layout is for reference purposes only.

NOTICE

JSCJ reserves the right to make modifications, enhancements, improvements, corrections or other changes without further notice to any product herein. JSCJ does not assume any liability arising out of the application or use of any product described herein.

SOT-223 Tape and Reel

SOT-223 Embossed Carrier Tape

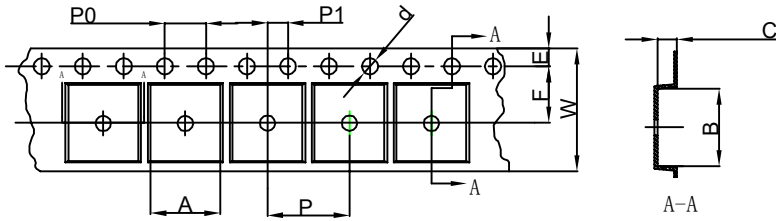

Packaging Description:

SOT-223 parts are shipped in tape. The carrier tape is made from a dissipative (carbon filled) polycarbonate resin. The cover tape is a multilayer film (Heat Activated Adhesive in nature) primarily composed of polyester film, adhesive layer, sealant, and anti-static sprayed agent. These reeled parts in standard option are shipped with 2,500 units per 13" or 33.0cm diameter reel. The reels are clear in color and is made of polystyrene plastic (anti-static coated).

Dimensions are in millimeter										
Pkg type	A	B	C	d	E	F	P0	P	P1	W
SOT-223	6.765	7.335	1.88	Ø1.50	1.75	5.50	4.00	8.00	2.00	12.00

SOT-223 Tape Leader and Trailer

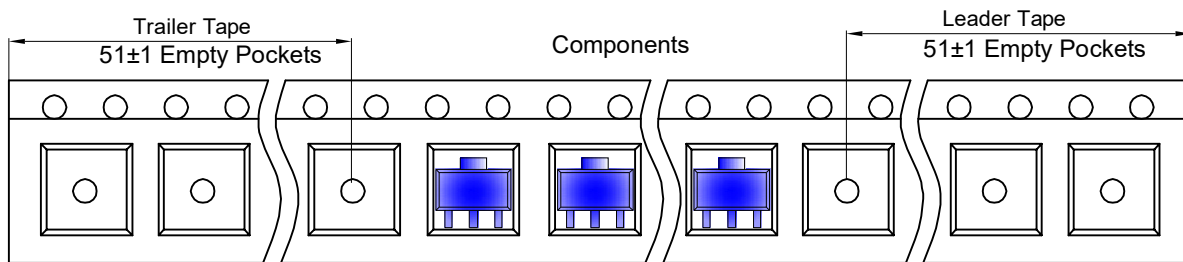

SOT-223 Reel

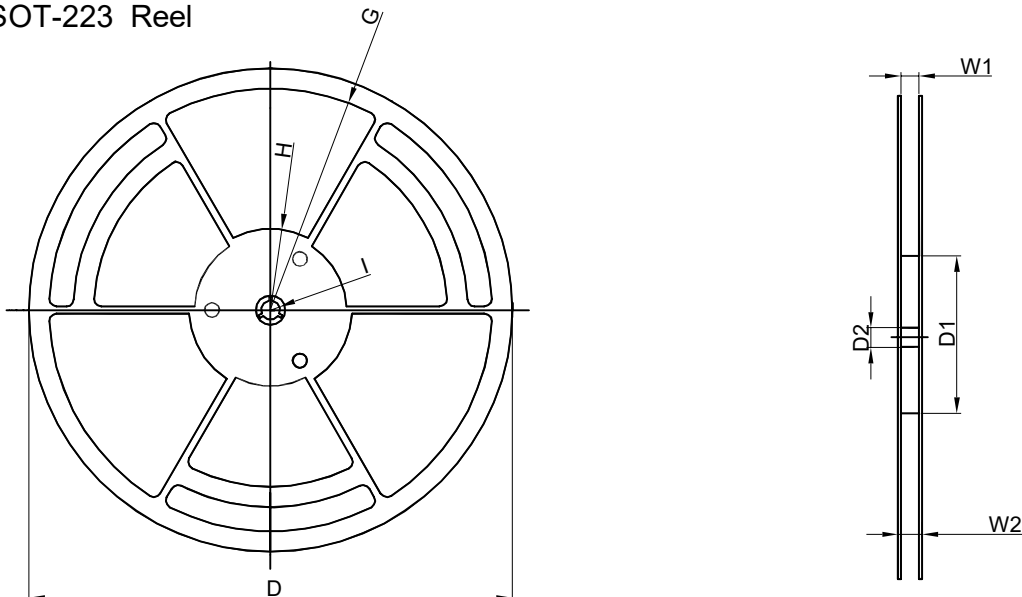

Dimensions are in millimeter								
Reel Option	D	D1	D2	G	H	I	W1	W2
13" Dia	Ø330.00	100.00	13.00	R151.00	R56.00	R6.50	12.40	17.60

REEL	Reel Size	Box	Box Size(mm)	Carton	Carton Size(mm)	G.W.(kg)
2,500 pcs	13 inch	2,500 pcs	336×336×48	20,000 pcs	445×355×365	

X-ON Electronics

Largest Supplier of Electrical and Electronic Components

Click to view similar products for [Linear Voltage Regulators](#) category:

Click to view products by [Changjing Electronics Technology](#) manufacturer:

Other Similar products are found below :

[LV56831P-E](#) [LV5684PVD-XH](#) [MCDTSA6-2R](#) [L7815ACV-DG](#) [PQ3DZ53U](#) [LV56801P-E](#) [TLE42794G](#) [L78L05CZ/1SX](#) [L78LR05DL-MA-E](#) [636416C](#) [714954EB](#) [BA033LBSG2-TR](#) [LV5680P-E](#) [L78M15CV-DG](#) [TLS202B1MBV33HTSA1](#) [L79M05T-E](#) [TLS202A1MBVHTSA1](#) [L78LR05D-MA-E](#) [NCV317MBTG](#) [NTE7227](#) [LV5680NPVC-XH](#) [LT1054CN8](#) [MP2018GZD-5-Z](#) [MP2018GZD-33-Z](#) [MIC5281-3.3YMM](#) [RT9078-28GQZ](#) [MC78L06BP-AP](#) [TA48LS05F\(TE85L,F\)](#) [TA78L12F\(TE12L,F\)](#) [TC47BR5003ECT](#) [TCR2LN12,LF\(S](#) [TCR2LN28,LF\(S](#) [TCR2LN30,LF\(S](#) [TCR3DF295,LM\(CT](#) [TCR3DF40,LM\(CT](#) [BA178M20CP-E2](#) [L78M12ABDT](#) [LM7812SX/NOPB](#) [LR645N3-G-P003](#) [LR645N3-G-P013](#) [ZXTR2005P5-13](#) [SCD7812BTG](#) [TCR3DF335,LM\(CT](#) [ZXTR2012K-13](#) [TLE42994E V33](#) [ZXTR2008K-13](#) [ZXTR2005K-13](#) [LA5693D-E](#) [L88R05DL-E](#) [ADP3300ARTZ-2.7RL7](#)