

Specification  
No. G190280B0182Z1 - 1 to 11

YUANLIU

Conductive polymer Aluminum Solid Capacitors  
Specifications

Customer Part No. : \_\_\_\_\_

Customer Specification No. : \_\_\_\_\_

Nippon Chemi-Con Part No. : APXF250ARA470MF611

Nippon Chemi-Con Corporation

Chemi-Con Miyagi Corporation

Design Group Manager

*K. Hatanaka*

Kazuhiro Hatanaka

\_\_\_\_\_  
Receipt Stamp

### Change history of specifications

Specifications No.	Revision date	Pages/section revised	Changes made	Reasons for changes
G190280B0182Z1	Apr.26.2019	—	First issue	—

## 1 Scope

These specifications define the requirements for surface mount conductive polymer aluminum electrolytic capacitors PXF series.

## 2 Part Numbering System

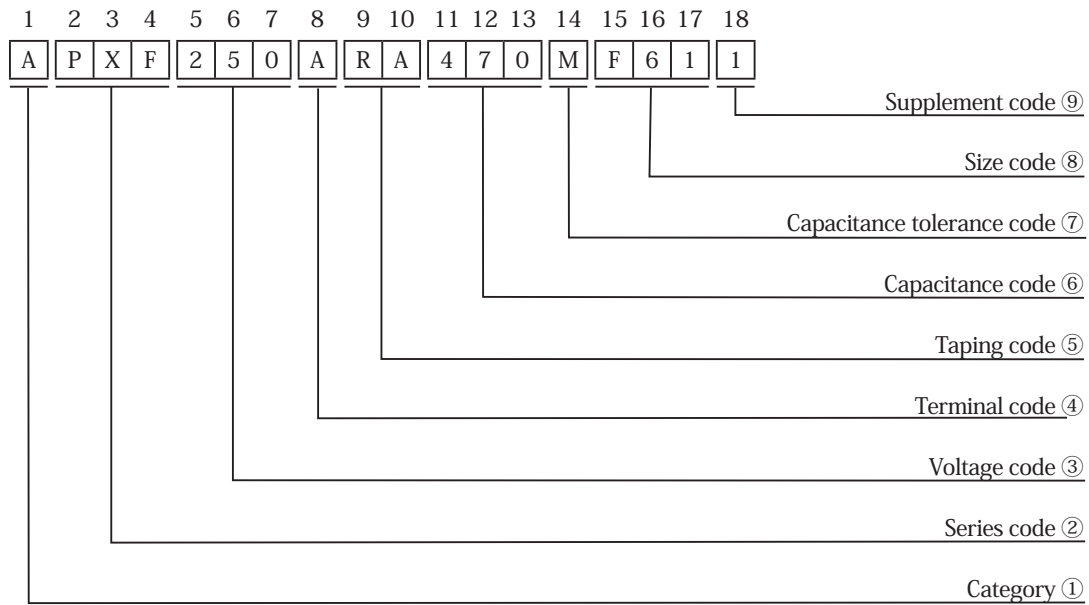

### ① Category

Category	Code
	1st
Polar	A

### ⑥ Capacitance code

Capacitance [ $\mu$ F ]	Capacitance code		
	11th	12th	13th
47	4	7	0

### ② Series code

Series name	Series code		
	2nd	3rd	4th
PXF	P	X	F

### ⑦ Capacitance tolerance code

Capacitance tolerance [% ]	Capacitance tolerance code
	14th
$\pm 20$	M

### ③ Voltage code

Voltage [V]	Voltage code		
	5th	6th	7th
25	2	5	0

### ⑧ Size code

$\phi$ D [mm]	Size code	L [mm]	Size code	
	15th		16th	17th
6.3	F	5.8	6	1

### ④ Terminal code

Type	Terminal code
	8th
SMD	A

### ⑨ Supplement code

Halogen-Free	Supplement code
	18th
	1

### ⑤ Taping code

Taping type	Reel dia. $\phi$ [mm]	Taping code	
		9th	10th
Plastic Reel	380	R	A

### 3 Appearance and dimensions

#### 3.1 Dimension

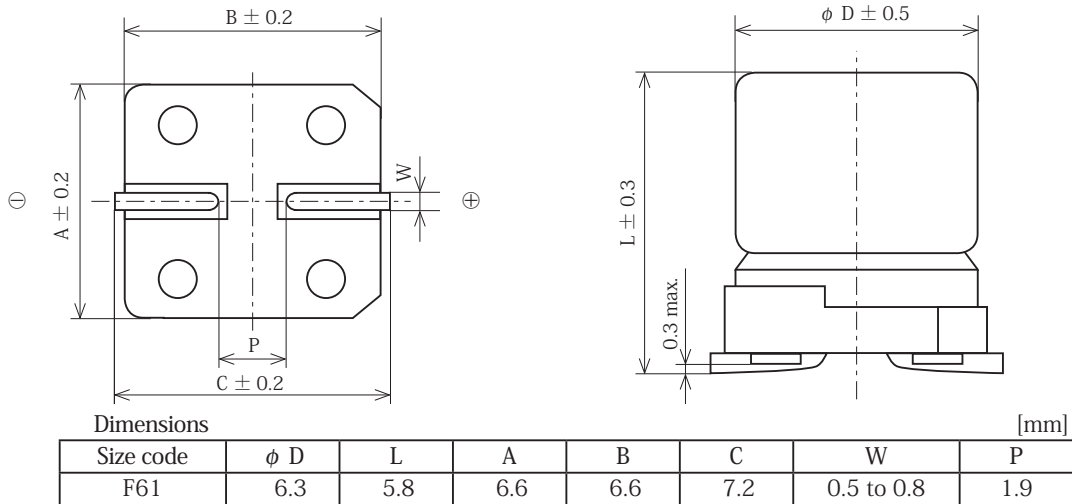

#### 3.2 Recommended solder land on PC board

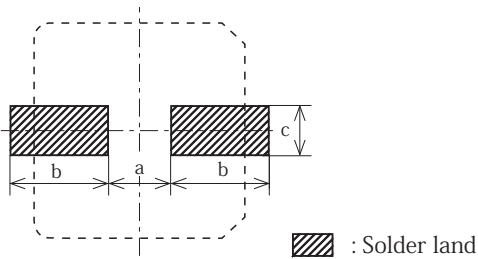

Land dimensions [mm]			
Size code	a	b	c
F61	1.9	3.5	1.6

### 4 Construction

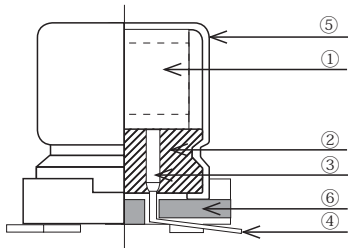

No.	Compositions	Materials
①	Anode foil	Aluminum
	Cathode foil	Aluminum
	Separator	Synthetic fiber
	Fixing tape	Heat-resistant resin tape
②	Seal	Rubber (IIR)
③	Aluminum tab	Aluminum
④	Lead wire	Bismuth-containing tinned copper clad steel Bismuth-containing tinned copper lead wire
⑤	Case	Resin-coated aluminum
⑥	Base plate	Resin

※ No ozone depleting substance has been used.

Compliant to the RoHS Directive (2011/65/EU) and the revisions (2015/863/EU)  
Halogen-Free

### 5 Substance Requirements

All homogeneous materials within a component or product must meet the criteria in Table-1, and Table-2. A homogeneous material has uniform composition throughout and cannot be mechanically disjoined into different materials.

Table-1 Substance restrictions for halogen-free products.

Substance	Permissible Limit (by weight)
Bromine (Br)	$\leq 900\text{ppm}$ (0.09%)
Chlorine (Cl)	$\leq 900\text{ppm}$ (0.09%)
Total concentration of chlorine (Cl) + bromine (Br)	$\leq 1500\text{ppm}$ (0.15%)

Table-2 Additional substance restrictions.

Substance	Permissible Limit (by weight)
Antimony Trioxide ( $\text{Sb}_2\text{O}_3$ )	$\leq 1000\text{ ppm}$ (0.1%)
Red Phosphorus	$\leq 1000\text{ ppm}$ (0.1%)

## 6 Rating and characteristics

No.	Item	Specification
1	Category temperature range	- 55 to + 105°C
2	Rated voltage range	25 V <sub>DC</sub>
3	Surge voltage	See Table-1
4	Rated capacitance range	See the standard rating table
5	Capacitance tolerance	- 20 to + 20%
6	Dissipation factor (tan δ )	0.12 max.
7	Leakage current	See the standard rating table
8	Rated ripple current	See the standard rating table
9	Equivalent series resistance	See the standard rating table

Table-1 Surge voltage

Rated voltage [V <sub>DC</sub> ]	25
Surge voltage [V <sub>DC</sub> ]	29

Rated ripple current multipliers

Frequency multipliers

Frequency[Hz]	120	1k	10k	50k	100k to 500k
Rated voltage[V <sub>DC</sub> ]					
25	0.05	0.30	0.55	0.70	1.00

When a frequency is different from the specified condition shown in the table of standard ratings, do not exceed the value obtained by multiplying the permissible maximum ripple current by the multiplier above.

## 7 Marking

The following items shall be marked on each capacitor.

- ① Rated voltage
- ② Rated capacitance
- ③ Negative polarity marking
- ④ Lot No.
- ⑤ Series code 「F」

(Example)

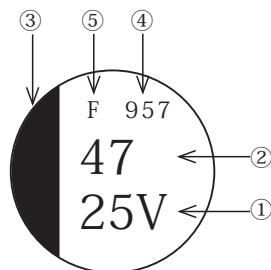

## 8 Performance

Unless otherwise specified, the capacitors shall be measured at a temperature of + 15 to + 35°C , a humidity of 45 to 75% RH and a atmospheric pressure of 86 to 106kPa. However, if any doubt arises on the judgment, the measurement conditions shall be + 20 ± 2°C , 60 to 70% RH and 86 to 106kpa.

### 8.1 Leakage current (L.C.)

[Conditions] Rated voltage shall be applied to capacitors in series with a resistor of  $1000 \pm 10 \Omega$  . Then, the leakage current shall be measured at two minutes later after the capacitors reached the rated voltage across the terminals, which is performed after the following voltage treatment.

[Voltage treatment]

A DC voltage equal to the rated voltage shall be applied to capacitors in series with a resistor of  $1000 \pm 10 \Omega$  for two hours at + 105 ± 2°C . Then, after restored to an ambient temperature, the capacitors are discharged through a resistor of about 1 Ω /V and left as it is in standard condition for 24 hours. (Note: The voltage treatment may be omitted.)

[Criteria] Shall not exceed the values specified in the table of Standard Ratings.

## 8.2 Capacitance (Cap.)

[Conditions]	Measuring frequency	: 120Hz $\pm$ 20%
	Measuring voltage	: 0.5V rms max. A bias voltage of 0.7 to 1.0V may be applied to prevent applying a reverse voltage.
	Measuring circuit	: Series equivalent circuit (○— — $\text{W}$ —○)
[Criteria]	Shall be within the specified capacitance tolerance.	

## 8.3 Dissipation factor (tan $\delta$ )

[Conditions]	Measuring frequency	: 120Hz $\pm$ 20%
	Measuring voltage	: 0.5V rms max. A bias voltage of 0.7 to 1.0V may be applied to prevent applying a reverse voltage.
	Measuring circuit	: Series equivalent circuit (○— — $\text{W}$ —○)
[Criteria]	0.12 max.	

## 8.4 Equivalent series resistance (ESR)

[Conditions]	Measuring frequency	: 100k to 300kHz $\pm$ 10kHz
	Measuring voltage	: 0.5V rms max. A bias voltage of 0.7 to 1.0V may be applied to prevent applying a reverse voltage.
	Ambient temperature	: + 20 $\pm$ 2°C
[Criteria]	Shall not exceed the values specified in the table of Standard Ratings.	

## 8.5 Soldering heat

[Conditions]	The capacitor shall be soldered according to recommended reflow soldering conditions, and then restored at + 20°C for the measurements.	
[Criteria]	Appearance	: No significant damage and legible marking.
	Leakage current	: Shall not exceed the initial specified value (after the voltage treatment).
	Capacitance change	: Shall be within the specified tolerance range.
	Tan $\delta$	: Shall not exceed the initial specified value.
	ESR	: Shall not exceed the initial specified value.

### SOLDERING METHODS AND THEIR RECOMMENDED CONDITIONS (Air reflow or Infrared reflow)

The following conditions are recommended for air or infrared reflow soldering of the surface mount capacitors onto a glass epoxy circuit board of 90<sup>L</sup> × 50<sup>W</sup> × 0.8<sup>mm</sup> (With resist) by cream solder. The shown temperatures are the surface temperature values on the top of the can and on the capacitor terminal.

Reflow should be performed twice or less.

Please ensure that the capacitor became cold enough to the room temperature (5 to 35°C) before the second reflow.

(The reflow soldering conditions are different between the first reflow and the second reflow.)

#### 《REFLOW TEMPERATURE PROFILE》

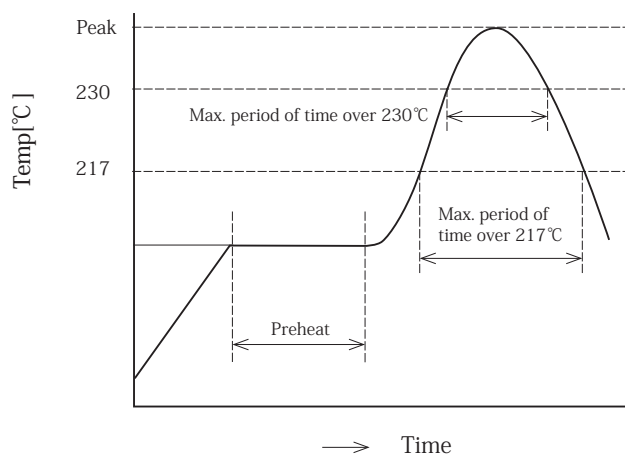

Preheat	Time maintained above 217°C	Time maintained above 230°C	Peak temp.	Reflow number
150 to 180°C 120 sec.max.	50 sec.max.	40 sec.max.	260°C max.	1-cycle only
			250°C max.	2-cycle allowed

## 8.6 Solderability

[Conditions]	Type of solder	: Sn-3Ag-0.5Cu
	Flux	: Ethanol solution (25 wt.% rosin)
	Solder temperature	: + 245 ± 3°C
	Immersion time	: 3 ± 0.3 sec.
[Criteria]	Solder shall cover at least 3/4 of the lead surface immersed.	

## 8.7 Adhesion

[Conditions]	A force of 5N shall be applied to the center of the plane parallel to the line connecting the centers of terminals and at right angles to the plane of a PC board, the direction of which shall be at right angles to the plane. The force shall be applied to the capacitor body gradually without any shock and kept for 10 ± 1 seconds.	
[Criteria]	No visible damage.	

## 8.8 Rapid change of temperature

[Conditions]

Step	
1	+ 105 ± 2°C                      30 ± 3min.
2	Three minutes or less
3	- 55 ± 3°C                        30 ± 3min.
4	Three minutes or less

Number of cycles: Five cycles

[Criteria]	Leakage current	: Shall not exceed the initial specified value (after the voltage treatment).
	Capacitance change	: Shall be within ± 10% of the initial measured value
	Tan δ	: Shall not exceed the initial specified value.
	ESR	: Shall not exceed the initial specified value.

## 8.9 Vibration

[Conditions]	Vibration frequency range	: 10 to 55Hz
	Amplitude or Acceleration	: 0.75mm (Half amplitude) or 100m/s <sup>2</sup>
	Sweep rate	: 10 to 55 to 10Hz in about 1 minute
	Direction and period of motion	: 2 hours in each of 3 mutually perpendicular directions (total of 6 hours)
[Criteria]	Appearance	: No significant damage and legible marking.
	Capacitance change	: Shall be within ± 10% of the initial measured value.

## 8.10 Damp heat

[Conditions]	The following specifications shall be satisfied when the capacitors are restored to + 20°C after the rated voltage applied for 1,000 <sup>+48</sup> <sub>0</sub> hours at + 60°C , 90 to 95 % RH.	
[Criteria]	Appearance	: No significant damage and legible marking.
	Leakage current	: Shall not exceed the initial specified value.
	Capacitance change	: Shall be within ± 20% of the initial measured value.
	Tan δ	: Shall not exceed 150% of the initial specified value.
	ESR	: Shall not exceed 150% of the initial specified value.

## 8.11 Endurance

[Conditions]	The following specifications shall be satisfied when the capacitors are restored to + 20°C after the rated voltage is applied for 15,000 <sup>+72</sup> <sub>0</sub> hours at + 105 ± 2°C .	
[Criteria]	Appearance	: No significant damage and legible marking.
	Leakage current	: Shall not exceed the initial specified value.
	Capacitance change	: Shall be within ± 20% of the initial measured value.
	Tan δ	: Shall not exceed 150% of the initial specified value.
	ESR	: Shall not exceed 150% of the initial specified value.

## 8.12 Surge voltage test

[Conditions]	After one-and-a-half as high voltage as the rated voltage shall be applied to capacitors 1000 times of 30 seconds of charging time and 5 minutes 30 seconds of discharging time through a series protective resistor of 1000 Ω at a temperature of + 105 ± 2°C . the following specifications shall be satisfied when the capacitors are restored to + 20°C .	
[Criteria]	Appearance	: No significant damage and legible marking.
	Leakage current	: Shall not exceed the initial specified value (after the voltage treatment).
	Capacitance change	: Shall be within ± 20% of the initial measured value.
	Tan δ	: Shall not exceed 150% of the initial specified value.
	ESR	: Shall not exceed 150% of the initial specified value.

### 8.13 High and Low Temperature characteristics

[Conditions]

Step	Temperature[°C]
1	+ 20 ± 2
2	- 55 ± 3
3	+ 105 ± 2

Step1 : Measure capacitance,  $\tan \delta$ , a leakage current and impedance.

2 : Measure capacitance and impedance.

3 : Measure capacitance,  $\tan \delta$ , a leakage current and impedance.

[Criteria]

Step 2	Capacitance change	: Shall be within ± 20% of Step 1
	Impedance(100kHz ± 10kHz)	: Shall not exceed 1.25 times of the initial specified value
	Tan $\delta$	: Shall not exceed the initial specified value
Step 3	Leakage current	: Shall not exceed 12.5 times of the initial specified value
	Capacitance change	: Shall be within ± 20% of Step 1
	Impedance(100kHz ± 10kHz)	: Shall not exceed 1.25 times of the initial specified value
	Tan $\delta$	: Shall not exceed the initial specified value

### 8.14 Assured Failure Rate

0.5% /1000 hours max. (at 105°C Confidence level 60%)

## 9 Reference standard

PXF series is applicable to the surface mount conductive polymer aluminum electrolytic capacitors based on JEITA RC2460 (IEC 60384-25 / JIS 5101-25). The others test conditions shall comply with JIS C 5101-1 1998.

## 10 Others

### 10.1 Export Trade Control Ordinance (To be complied for aluminum electrolytic capacitors be exported from Japan)

#### (1) Export Trade Control Ordinance (Section 1 through 15 of Appendix Table 1)

Export regulation of the capacitors for pulse use (750V or higher) and the capacitors for high voltage (5,000V or higher) is carried out according to (item 41-4) in Section 2 of Appendix Table 1 (Section 49 in Chapter 1 of METI's Ordinance) and (item 7) in Section 7 of Appendix Table 1 (Section 6 in Chapter 6 of METI's Ordinance). However, the aluminum electrolytic capacitors, which are described in this specification, don't fulfill the regulated level. Therefore, the aluminum electrolytic capacitors are not applicable to Export Trade Control Ordinance.

#### (2) Export Trade Control Ordinance (Section 16 of Appendix Table 1)

The aluminum electrolytic capacitors, which are described in this specification, applicable to goods under Export Regulations (Category 85 of Appendix Table in Customs Tariff Law) based on Section 16 of Appendix Table 1 in Export Trade Control Ordinance.

If the exporter got information that their exporting goods are used to any development of massive weapon, the exporter must apply for exporting permission to Ministry of Economy, Trade and Industry (METI), and get METI's approval.

Regardless of the above, if the exporter is notified by METI that his/her exporting goods are potentially used to any development of extensive destructive weapons, the exporter must seek permission from METI to export, and get METI's approval. When Nippon Chemi-Con receives such notice from METI, we will inform your company of that.

### 10.2 Manufacturing plant

CHEMI-CON MIYAGI CORPORATION (JAPAN)

CHEMI-CON YAMAGATA CORPORATION YONEZAWA PLANT (JAPAN)

TAIWAN CHEMI-CON (TAIWAN)

### 10.3 For aluminum electrolytic capacitors, please refer to PRECAUTIONS AND GUIDELINES (Conductive Polymer).



## 11 Taping

### 11.1 Scope

This specification defines the taping requirements for aluminum electrolytic capacitors, complying with JIS C 0806-3(1999).

### 11.2 Taping dimensions and taping configurations

#### (1) Carrier tape

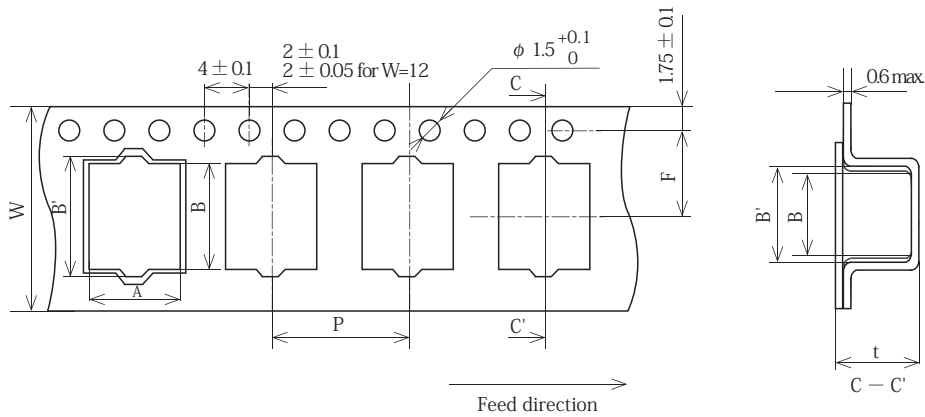

Carrier tape dimensions

Size code	$W \pm 0.3$	$A \pm 0.2$	$B \pm 0.2$	$B' \pm 0.2$	$F \pm 0.1$	$P \pm 0.1$	$t \pm 0.2$
F61	16.0	7.0	7.0	8.2	7.5	12.0	6.3

#### (2) Edges of carrier tape and cover tape

The cover tape shall not extend more than 0.5mm beyond the edge of the carrier tape.

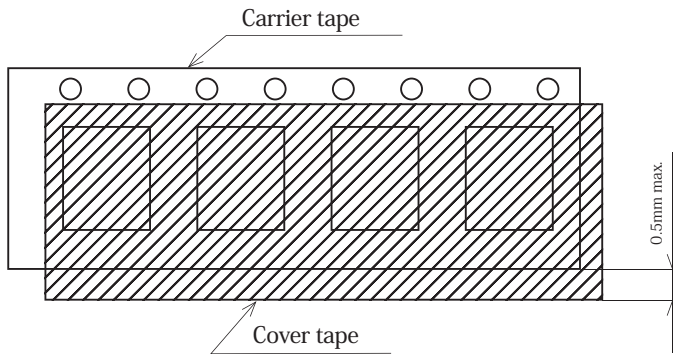

The cover tape shall not extend exceeding 0.75mm to the sprocket holes.

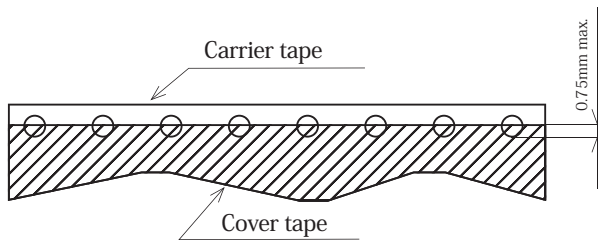

### 11.3 Taping method and polarity

#### (1) Polarity

The parts shall be so oriented that their positive polarity shall be the right side for the direction of unreeling. (Except for bi-polarized capacitors)

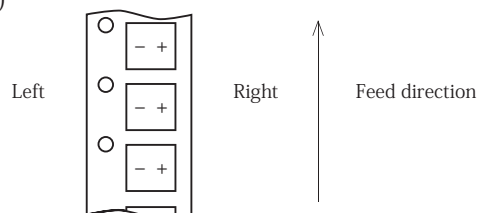

**(2) Peeling strength of cover tape**

- 1) Rupture strength of cover tape : 10N min.
- 2) Peeling strength of cover tape
  - ① Peeling angle : 165 to 180° to adhesive surface
  - ② Peel-off speed : 300 ± 10 mm/minute
  - ③ Peeling force : 0.1N to 1.3N

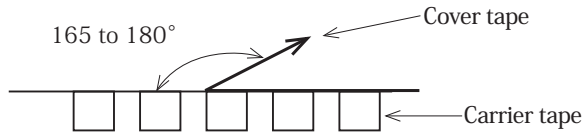

**3) Other**

When the cover tape is taken off and the carrier tape turned upside down, all of the parts shall fall out of the carrier tape.

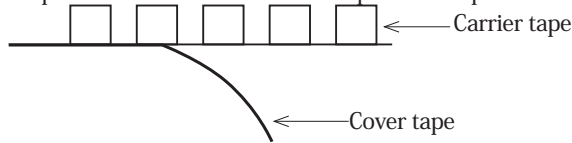

**(3) Taping method and marking**

1) Taping method is shown below.

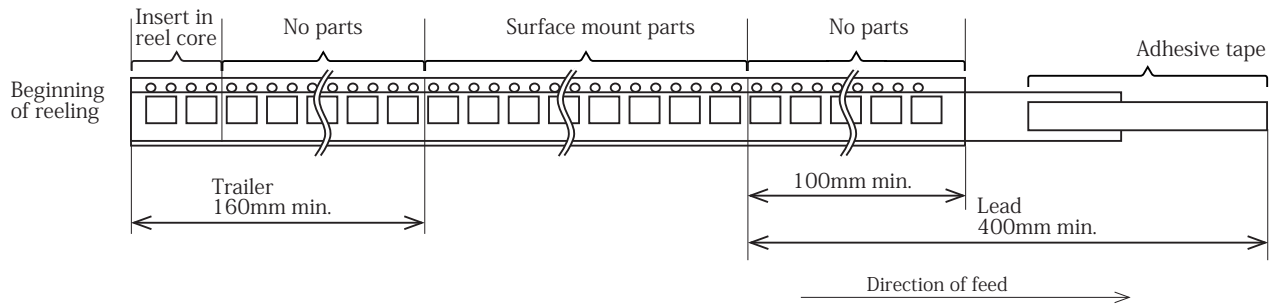

**2) Marking of reel**

The following marking shall be printed on the reel.

- ① Part Numbering System
- ② Lot No.
- ③ Manufacturer's name
- ④ Quantity

**(4) Reel dimensions**

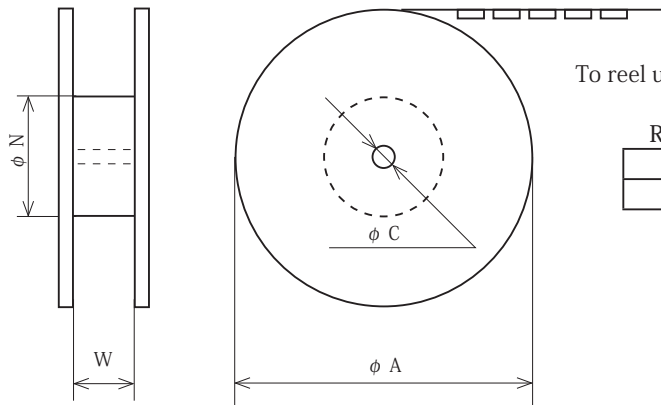

To reel up the tape so that the parts can face the reel core.

Reel dimensions [mm]				
Size code	W	φ N min.	φ A max.	φ C ± 0.5
F61	18	50	382	13

#### 11.4 Packaging quantity and Packaging box

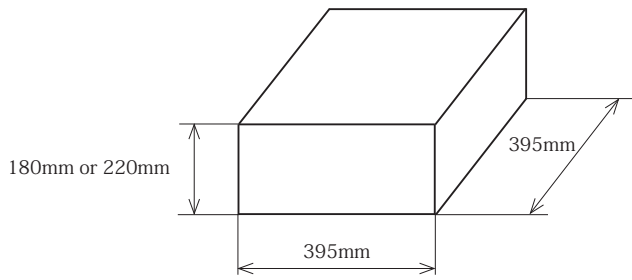

Dump-proof packing  
(Aluminum dump-proof packing bag)

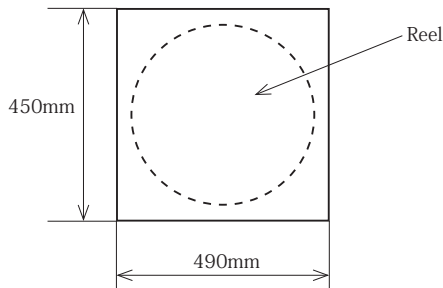

※ The dimensions may change according to the size of the reel.

Quantity per reel/box

Size code	Quantity		
	pcs/reel	pcs/box	reel/box
F61	1,000	7,000	7

This may change according to a delivered quantity.

#### 11.5 Others

- (1) Missing parts shall be no more than 0.1% of the total packaging quantity.
- (2) Carrier tapes may be spliced and/or a part of cover tapes may be spliced with an adhesive tape, because of manufacturing reasons.
- (3) Please finish up the products the aluminum dump-proof packing bag of which is opened. When arose the stub, please return the products into the packing bag, and keep it after sealing by the zipper.

#### STANDARD RATINGS

WV [Vdc]	Cap [ $\mu$ F]	Size code	LC [ $\mu$ A] Max.	ESR [m $\Omega$ Max./20°C]	Rated ripple current [mArms/105°C]	Part No.
			2minutes	100k to 300kHz	100kHz	
25	47	F61	235	30	2800	APXF250ARA470MF611

# PRECAUTIONS AND GUIDELINES (Conductive Polymer)

The NPCAP™ is a Conductive Polymer Solid Aluminum Capacitor that uses highly conductive polymer electrolytic material. Please read the following in order to get the most out of your NPCAP™ capacitor.

## **[1] Designing Device Circuits**

---

### **1) Types of Circuits Where NPCAP™ Capacitors are Not to be Used**

The leakage current in conductive polymer solid aluminum capacitors (hereafter called capacitors) may vary depending on thermal stresses during soldering. Avoid the use of capacitors in the following types of circuits:

- ① High-impedance circuits that are to sustain voltages.
- ② Coupling circuits
- ③ Time constant circuits

Because the capacitance varies depending on the environment the capacitors are used in, there is a possibility that the capacitor can affect a time constant circuit where sensitivity to variation in capacitance is required.

- ④ Other circuits that are significantly affected by leakage current

### **2) Circuit Design**

Verify the following before designing the circuit:

- ① The electrical characteristics of the capacitor will vary depending on differences in temperature and frequency. Only design your after verifying the scope of these factors.
- ② When connecting two or more capacitors in parallel, ensure that the design takes current balancing into account.
- ③ When two or more capacitors are connected in series, variability in applied voltage may cause over-voltage conditions. Contact Nippon Chemi-Con before using capacitors connected in series.
- ④ Avoid putting heat generating parts either around the capacitor or on the reverse of the circuit board.

### **3) Use in High Reliable and Critical Applications**

Consult with us in advance of usage of our products in the following listed applications. ① Aerospace equipment ② Power generation equipment such as thermal power, nuclear power etc. ③ Medical equipment ④ Transport equipment (automobiles, trains, ships, etc.) ⑤ Transportation control equipment ⑥ Disaster prevention / crime prevention equipment ⑦ Highly publicized information processing equipment ⑧ Submarine equipment ⑨ Other applications that are not considered general- purpose applications.

### **4) Polarity**

The NPCAP™ is a polarized solid aluminum electrolytic capacitor. Do not apply either reverse voltages or AC voltages to the polarized capacitors, using reversed polarity may cause a short circuit. Refer to the catalog, product specifications or capacitor body to confirm the polarity prior to use.

### **5) Operating Voltage**

Do not apply a greater than rated voltage, if a voltage greater than the rated voltage is suddenly applied the leakage current increases causing shorting. The peak voltage of superimposed AC voltages (ripple voltages) on DC voltages must not exceed the full rated voltage. Capacitors do not require voltage derating within the category temperature. While there are specifications for surge voltages exceeding the rated voltage, usage conditions apply, and continued operation for extended periods of time under such conditions cannot be guaranteed.

### **6) Ripple Current**

Do not apply currents in excess of the rated ripple current. The superimposition of a large ripple current increases the rate of heating within the capacitor. When excessive ripple current is imposed the internal temperature increases which can shorten life and shorting may occur.

### **7) Operating Temperature**

Use within the stated category temperature range, if used outside this range, characteristics can deteriorate potentially leading to problems.

### **8) Charging and Discharging the Capacitor**

Do not use the NPCAP™ capacitor in circuits where the capacitor is repetitively charged and discharged rapidly. Repetitively charging and discharging the capacitor rapidly may reduce the capacitance or may cause damage due to internal heating. Use of a protective circuit to ensure reliability is recommended when rush currents exceed 20A.

### **9) Leakage current**

The leakage current may increase when the capacitors are subjected to the conditions below. After that, however, the leakage current will gradually decrease by self-healing action of the dielectric oxide layer when the capacitors are applied with a voltage less than the rated voltage within the Category Temperature range. As the voltage is closer to the rated voltage and the temperature is closer to the upper limit of Category Temperature range, the leakage current decreases faster.

The leakage current will increase by the following factors,

- ① Soldering
- ② Testing of high temperature exposure with no voltage applied, high temperature/humidity storage, temperature cycles, etc.

### **10) Failures and Service Life**

Based on the JIS C 5003 Standard, the failure rate for NPCAP™ capacitors (with a 60% reliability standard) is as follows:  
0.5% / 1,000 hours (applied the rate voltage at the upper limit of Category Temperature range)

### (1) Failure Modes

- ① The principal failure mode is wear-out failure, that is, capacitance decreases and ESR increases, and eventually the capacitors become open circuit failure. In addition, short circuit failure may happen with over-voltage and excessive current applied to the capacitors.
- ② The failure rate would be reduced by reducing ambient temperatures, ripple current and applying voltage.
- ③ If the short-circuited capacitor, which may be caused by over-voltages higher than the rated voltage or other conditions, has a large amount of current passed through, the aluminum can of the capacitor bulges and might be expelled with odor gas emitted.
- ④ The product contains flammable materials. If the short causes a spark it may ignite. Please be careful when installing the product, its position and the layout design.
  - Increase safety by using in conjunction with a protective circuit or protective equipment.
  - Install measures such as redundant circuits so that the failure of a part of the equipment will not cause unstable operation.

### (2) Service Life

SMD (Chip type) uses rubber as the sealing material, so the service life depends on the thermal integrity of this rubber.

When long life performance is required in actual use, please use the capacitor at lower temperature within the category temperature.

### 11) Capacitor Insulation

Insulation of the capacitor's case is not guaranteed. Ensure electrical insulation between the capacitor case, negative electrode, positive electrode and circuit pattern.

### 12) Capacitor Usage Environment

Do not use/expose capacitors to the following conditions.

- ① Oil, water, salty water, take care to avoid storage in damp locations.
- ② Direct sunlight
- ③ Toxic gases such as hydrogen, sulfur dioxide, sulfurous acids, nitrous acids, chlorine and chlorine compounds, bromine and bromine compounds, ammonia, etc.
- ④ Ozone, ultraviolet rays and radiation.
- ⑤ Severe vibration or mechanical shock conditions beyond the limits advised in the product specification section of the catalog.  
The standard vibration condition is applicable to JIS C 5101-4.

### 13) Capacitor mounting

- ① For the surface mount capacitor, design the copper pads on the PC board in accordance with the catalog or the product specification
- ② Do not pass any circuit traces beneath the seal side of a capacitor. The trace must pass 1 to 2mm to the side of the capacitor.
- ③ Do not pass any via holes underneath a capacitor on double sided PC board
- ④ In designing double-sided PC boards, do not locate any copper trace under the seal side of a capacitor

## [2] Installing Capacitors

---

### 1) Installing

- ① Do not reuse capacitors already assembled in equipment that have been exposed to power.
- ② The capacitor may have self charge. If this happens, discharge the capacitor through a resistor of approximately 1k  $\Omega$  before use.
- ③ If capacitors are stored at a temperature of 35°C or more and more than 75% RH, the leakage current may increase. This may also occur if the capacitors are stored for a longer period than the period which is specified in the catalog or the product specification. In this case, they can be reformed by the voltage treatment through a resistor of approximately 1k  $\Omega$ .
- ④ Verify the rated capacitance and voltage of the capacitors when installing.
- ⑤ Verify the polarity of the capacitors.
- ⑥ Do not use the capacitors if they have been dropped on the floor.
- ⑦ Do not deform the case of the capacitors.
- ⑧ Do not apply any mechanical force in excess of the limits prescribed in the catalog or the product specification of the capacitors. Avoid subjecting the capacitor to strong forces, as this may break the electrode terminals, bend or deform the capacitor, or damage the packaging, and may also cause short/open circuits, increased leakage current, or damage the appearance. Also, note the capacitors may be damaged by mechanical shocks caused by the vacuum/insertion head, component checker or centering operation of an automatic mounting or insertion machine.

### 2) Heat Resistance during Soldering

Ensure that the soldering conditions meet the specifications recommended by Nippon Chemi-Con. Note that the leakage current may increase or capacitance may decrease due to thermal stresses that occur during soldering, etc. Furthermore, the leakage current which rose gradually decreases, when voltage is applied at below the category upper limit temperature. Additionally the self repairing action is faster when voltage near the rated voltage rather than at a higher voltage is applied at below the category's upper temperature limit.

- ① Verify the following when reflow soldering:
  - Soldering conditions (preheat, solder temperature and soldering time) should be within the limits prescribed in the catalogs or the product specification.
  - The heat level should be appropriate. (Note that the thermal stress on the capacitor varies depending on the type and position of the heater in the reflow oven, and the color and material of the capacitor.)
  - Please consult us about Vapor phase soldering (VPS).
  - Except for the surface mount type, reflow soldering must not be used for the capacitors.
  - Flow soldering must not be used.
- ② Do not reuse a capacitor that has already been soldered to PC board and then removed. When using a new capacitor in the same location, remove the flux, etc. first, and then use a soldering iron to solder on the new capacitor in accordance with the specifications.

### 3) Handling After Soldering

Do not apply any mechanical stress to the capacitor after soldering onto the PC board.

- ① Do not lean or twist the body of the capacitor after soldering the capacitors onto the PC board.
- ② Do not use the capacitors for lifting or carrying the assembly board.
- ③ Do not hit or poke the capacitor after soldering to PC board. When stacking the assembly board, be careful that other components do not touch the aluminum electrolytic capacitors.
- ④ Do not drop the assembled board.

### 4) Cleaning PC boards

① Do not wash capacitors by using the following cleaning agents. Solvent resistant capacitors are only suitable for washing using the cleaning conditions prescribed in the catalog or the product specification. In particular, ultrasonic cleaning will accelerate damage to capacitors.

- Halogenated solvents; cause capacitors to fail due to corrosion.
- Alkali system solvents; corrode (dissolve) an aluminum case.
- Petroleum system solvents; cause the rubber seal material to deteriorate.
- Xylene; causes the rubber seal material to deteriorate.
- Acetone; erases the markings.

CFC alternatives or the other cleaners above; please consult with us

② Verify the following points when washing capacitors.

- Monitor conductivity, pH, specific gravity and the water content of cleaning agents. Contamination adversely affects these characteristics.
- Be sure not to expose the capacitors under solvent rich conditions or keep capacitors inside a closed container. In addition, please dry the solvent sufficiently on the PC board and the capacitor with an air knife (temperature should be less than the maximum rated category temperature of the capacitor) for 10 minutes. Aluminum electrolytic capacitors can be characteristically and catastrophically damaged by halogen ions, particularly by chlorine ions, though the degree of the damage mainly depends upon the characteristics of the electrolyte and rubber seal material. When halogen ions come into contact with the capacitors, the foil corrodes when a voltage is applied. This corrosion causes an extremely high leakage current which results venting and an open circuit.

If the new types of cleaning agents mentioned below are used, the following are recommended as cleaning conditions for some of new cleaning agents.

-Higher alcohol cleaning agents

Pine Alpha ST-100S (Arakawa Chemical)

Clean Through 750 H, 750K, 750L, and 710M (Kao)

Technocare FRW-14 through 17 (Momentive performance material)

Cleaning Conditions:

Using these cleaning agents, capacitors are capable of withstanding immersion or ultrasonic cleaning for 10 minutes at a maximum liquid temperature of 60°C. Find optimum condition for washing, rinsing, and drying. Be sure not to rub the marking off the capacitor which can be caused by contact with other components or the PC board. Note that shower cleaning adversely affects the markings on the sleeve.

-Non-Halogenated Solvent Cleaning

AK225AES (Asahi Glass)

Cleaning Conditions:

Immersion, ultrasonic or vapor cleaning for 5 minutes. However, from an environmental point of view, these types of solvent will be banned in near future. We would recommend not using them if at all possible.

-Isopropyl Alcohol (IPA)

IPA (Isopropyl Alcohol) is one of the most acceptable cleaning agents; it is necessary to maintain a flux content in the cleaning liquid at a maximum limit of 2 Wt.%.

### 5) Precautions for using adhesives and coating materials

① Do not use any adhesive and coating materials containing halogenated solvent.

② Verify the following before using adhesive and coating material.

- Remove flux and dust left over between the rubber seal and the PC board before applying adhesive or coating materials to the capacitor.
- Dry and remove any residual cleaning agents before applying adhesive and coating materials to the capacitors. Do not cover over the whole surface of the rubber seal with the adhesive or coating materials.
- For permissible heat conditions for curing adhesives or coating materials, follow the instructions in the catalog or the product specification for the capacitors.
- Covering over the whole surface of the capacitor rubber seal with resin may result in a hazardous condition because the inside pressure cannot be completely released. Also, a large amount of halogen ions in resins will cause the capacitors to fail because the halogen ions penetrate into the rubber seal and the inside of the capacitor.
- Some coating materials, it cannot be implemented to the capacitor.

Please note change on the surface might be caused according to the kind of solvents used for mounting adhesives and coating agents.

## 6) Fumigation

In exporting or importing electronic devices, they may be exposed to fumigation with halide such as methyl bromide.

Where aluminum electrolytic capacitors are exposed to halide such as methyl bromide, the capacitors will be damaged with the corrosion reaction with halogen ions in the same way as cleaning agents. For the export and import, Nippon Chemi-Con considers using some packaging method and so forth so that fumigation is not required. For customers to export or import electronic devices, semi-assembly products or capacitor components, confirm if they will be exposed to fumigation and also consider final condition of packaging. (Note that either cardboard or vinyl package has a risk of fumigation gas penetration.)

## 【3】 The Operation of Devices

---

- 1) Do not touch the capacitor terminals directly.
- 2) Do not short-circuit the terminal of a capacitor by letting it come into contact with any conductive object. Also, do not spill electric-conductive liquid such as acid or alkaline solution over the capacitor.
- 3) Do not use capacitors in circumstances where they would be subject to exposure to the following materials
  - Oil, water, salty water or damp location.
  - Direct sunlight.
  - Ozone, ultraviolet rays or radiation.
  - Toxic gases such as hydrogen sulfide, sulfurous acid, nitrous acid, chlorine or its compounds, and ammonium.
  - Severe vibration or mechanical shock conditions beyond the limits prescribed in the catalog or product specification.The standard vibration condition is applicable to JIS C 5101-4.

## 【4】 Maintenance Inspection

---

- 1) Make periodic inspections of capacitors that have been used in industrial applications. Before inspection, turn off the power supply and carefully discharge the electricity in the capacitors. Verify the polarity when measuring the capacitors with a volt-ohm meter. Do not apply any mechanical stress to the terminals of the capacitors.
- 2) The following items should be checked during the periodic inspections.
  - ① Significant damage in appearance
  - ② Electrical characteristics: leakage current, capacitance,  $\tan \delta$  and other characteristics prescribed in the catalog or product specification.We recommend replacing the capacitors if the parts are out of specification.

## 【5】 Contingencies

---

- 1) If gas has vented from the capacitor during use, there is a short circuit and burning, or the capacitor discharges an odor or smoke, turn off the main power supply to the equipment or unplug the power cord.
- 2) If there is a problem with the capacitor or a fire breaks out, the capacitor may produce a burning gas or reactive gas from the outer resin, etc. If this happens, keep your hands and face away from the gas. If vented gas is inhaled or comes into contact with your eyes, flush your eyes immediately with water and/or gargle. If vented gas comes into contact with the skin, wash the affected area thoroughly with soap and water.

## 【6】 Storage

---

We recommend the following conditions for storage.

- 1) Store capacitors in a cool, dry place. Store at a temperature between 5 and 35C, with a humidity of 75% or less.  
(table-1 Maximum storage term)

	Before the bag is opened	After the bag is opened
SMD (Chip type)	Within 3 years after manufacturing	Within 6 months after the bag is opened

SMD products are sealed in a special laminated aluminum bag. Use all capacitors once the bag is opened. Return unused capacitors to the bag, and seal it with a zipper. Please refer to (Table -1 maximum storage term) for storage conditions. Be sure to follow our recommendations for reflow soldering.

- 2) Store the capacitors in a location free from direct contact with water, salt water, and oil.
- 3) Store in a location where the capacitor is not exposed to toxic gas, such as hydrogen sulfide, sulfurous acid, nitrous acid, chlorine or chlorine compounds, bromine or other halogen gases, methyl bromide or other halogen compounds, ammonia, or similar.
- 4) Store in a location where the capacitor is not exposed to ozone, ultraviolet radiation, or other radiation.
- 5) It is recommended to store capacitors in their original packaging wherever possible.
- 6) The JEDEC J-STD-020 standard does not apply.

## 【7】 Disposal

---

Please consult with a local industrial waste disposal specialist when disposing of aluminum electrolytic capacitors.

## **【8】 About AEC-Q200**

---

The Automotive Electronics Council (AEC) was originally established by major American automotive related manufactures. Today, the committees are composed of representatives from the sustaining Members of manufacturing companies in automotive electrical components. It has standardized the criteria for "stress test qualification" and "reliability tests" for electronic components.

AEC-Q200 is the reliability test standard for approval of passive components in Automotive applications. It specifies the test type, parameters and quantity, etc. for each component. The criteria of the reliability tests such as for our main products, "Aluminum Electrolytic Capacitors" are described in this standard.

Pursuant to the customer's specific testing requirements, Chemi-Con submits the test results according to AEC-Q200 for Aluminum Electrolytic Capacitors used in automotive applications on request.

An electronic component manufacturer cannot simply claim that their product is "AEC-Q200 Qualified". It can be claimed "Compliant", "Capable", "Available", etc., however each component must be tested per each users "Qualification Test Plan" in order to claim AEC-Q200 status.

Please contact us for more information.

## **【9】 Response to the Substances of Concern**

---

- 1) Nippon Chemi-Con aims for developing products that meet laws and regulations concerning substances of concern.

(Some products may contain regulated substances for exempted application)

Please contact us for more information about law-compliance status.

- 2) According to the content of REACH handbook (Guidance on requirements for substances in articles which is published on May 2008), our electronic components are "articles without any intended release". Therefore they are not applicable for "Registration" for EU REACH Regulation Article 7 (1).

Reference: Electrolytic Condenser Investigation Society

"Study of REACH Regulation in EU about Electrolytic Capacitor" (publicized on 13 March 2008)

## **【10】 Precautions and guidelines**

---

For more details, refer to JEITA RCR-2367C (March 2006) with the title of "Safety Application Guide for fixed aluminum electrolytic capacitors for use in electronic equipment".



## X-ON Electronics

Largest Supplier of Electrical and Electronic Components

*Click to view similar products for [Aluminium Organic Polymer Capacitors](#) category:*

*Click to view products by [Chemi-Con](#) manufacturer:*

Other Similar products are found below :

[750-1809](#) [SEAU0A0102G](#) [MPP104K6130714LC](#) [MPP223J5130508LC](#) [MPP104K6130612LC](#) [MPP684K4241219LC](#) [PPS333KD241017LC](#)  
[MPP472K4130408LC](#) [PCZ1V221MCL1GS](#) [HHXD500ARA470MHA0G](#) [NPXB1001B271MF](#) [NPXB1101B391MF](#) [NPXC0571B221MF](#)  
[NPXC0701B331MF](#) [NPXB0901B391MF](#) [NPXD0701A471MF](#) [HHXD630ARA330MJA0G](#) [HHXD350ARA270MF61G](#)  
[HHXD350ARA220ME61G](#) [HHXD350ARA101MHA0G](#) [HHXD350ARA680MF80G](#) [APXJ200ARA151MF61G](#) [RS81C271MDN1CG](#)  
[APSF6R3ELL821MF08S](#) [PM101M016E058PTR](#) [PM101M025E077PTR](#) [SPZ1EM221E10P25RAXXX](#) [APSE2R5ETD821MF08S](#)  
[SPZ1EM681F14O00RAXXX](#) [SPZ1AM102F11000RAXXX](#) [SPV1VM471G13O00RAXXX](#) [SPZ1VM821G18O00RAXXX](#)  
[SPV1HM331G15O00RAXXX](#) [SVZ1EM221E09E00RAXXX](#) [PM101M035E077PTR](#) [HV1A227M0605PZ](#) [HV1C107M0605PZ](#)  
[HV1C227M0607PZ](#) [HV1H107M0810PZ](#) [HV1E107M0607PZ](#) [HV1V106M0605PZ](#) [HV1V476M0605PZ](#) [HV1H227M1010PZ](#)  
[HV0J337M0607PZ](#) [HV1A477M0607PZ](#) [HV1E566M0605PZ](#) [HV1V227M0810PZ](#) [HV0J108M0810PZ](#) [M2101M035C070RT](#)  
[SVZ1EM471FBRE00RAXXX](#)