

Chengx[®]

东莞承兴电子有限公司

DONG GUAN SHI CHENG XING ELECTRONICS CO.,LTD

承 认 书

客户名称： 立创

客户料号： _____

零件名称： 铝电解电容器

承兴料号： GR108M010F12RR0VL4FP0

承认规格： 1000uF/10V 8*12 绿体金字

制作日期： 2018年6月22日

承办单位： 工程部

版 本： A-0

| 盖章处 | 核 准 | 审 核 | 制 作 |
|-----|-----|-----|-----|
| | 王根林 | 何国环 | 余淋淋 |

工厂地址：广东省东莞市长安镇沙头村新沙工业区

总部地址：广东省东莞市长安镇上沙村北横街8号凯韵大厦3楼

TEL: (0769)81604900、81604911、81604922

FAX: (0769)85648558、85498863

| 客户承认栏 Approved by | | | |
|----------------------|-----|-----|-----|
| 盖章处 | 核 准 | 审 核 | 承 办 |
| | | | |

承认盖章后请回传，感谢！

No.: CX-YX-0910-2.0

铝电解电容使用注意事项：

1、电路设计

(1) 在确认使用及安装环境时,作为按产品样本设计说明书所规定的额定性能范围内使用电容器,应当避免在下述情况下使用:

- a) 高温(温度超过最高使用温度);
- b) 过流(电流超过额定纹波电流);
- c) 过压(电压超过额定电压);
- d) 施加反向电压或交流电压;
- e) 使用于反复多次急剧充放电的电路中。

另: 1、在电路设计时,请选用与机器寿命相当的电容器。

2、机器性能有特殊要求时,可与研发人员探讨,制造适用的特规电容。

(2) 电容器外壳,辅助引出端子与正负以及电路析间必须完全隔离。

(3) 当电容器套管的绝缘不能保证时,在有绝缘性能特定要求的地方,请不要使用。

(4) 请不要在下述环境下使用电容器:

- a) 直接与水,盐水及油类相接触,或结露的环境;
- b) 充满有害气体环境(硫化物,H₂SO₃,HNO₃,CL₂,氨水等);
- c) 置于日照,O₃,紫外线及有放射性物质的环境;
- d) 振动及冲击条件超过了样本及说明书的规定范围的恶劣环境。

(5) 在设计电容器的安装时,必须确认下述内容:

- a) 电容器的正负极间距必须与线路板孔距吻合;
- b) 保证电容器防爆阀上方留有一定的空间;
- c) 电容器防爆上方尽量避免配线及安装其它元器件;
- b) 电路板上,电容器的安装位置,请不要有其它配线;
- e) 电容器四周及电路板上尽量避免设计,安装发热组件。

(6) 另外,在设计电路时,必须确认以下内容:

- a) 温度及频率的变化不至于引起电性能变化;
- b) 双面印刷板上安装电容器时,电容器的安装位置避免多余的基板孔和过孔;
- c) 两只以上的电容器并联连接时电流均衡;
- d) 两只以上的电容器串联连接时电压均衡。

2、组件安装

(1) 安装时,请遵守以下内容:

- a) 为了对电容器进行点检,测定电气性能时,除了卸下的电容器,装入机器中通过电的电容器 请不要再使用;
- b) 当电容器产生再生电压时,需通过约1KΩ左右的电阻进行放电;
- c) 长期保存的电容器,需通过约1KΩ左右的电阻加压处理;
- d) 确认规格(静电容量及额定电压等)及极性后,再安装;
- e) 不要讓電容器掉到地上,掉下的電容器請不要再使用;
- f) 变形的電容器不要再安装;
- g) 電容器正负极间距与电路板孔必须吻合;
- h) 自動插入機的机械手力量不宜過大。

(2) 焊接時,請確認下面內容

- a) 注意不要將焊錫附著在端子以外;
- b) 焊接條件(溫度,時間,次數)必須按規定說明執行;
- c) 不要將電容器本身浸入焊錫溶液中;
- d) 焊接時,不要讓其它產品倒下碰到電容器上。

(3) 焊接后处理应不产生以下机械应力

- a) 电容器发生倾倒,扭转;
- b) 电容器碰到其它的线路板;
- c) 使其它的物体碰撞到电容器。

(4) 电容器不要用洗净剂洗净,但是在有必要洗净的情况下对电容器进行洗净,必须在产品规格书规定范围内进行。

(5) 对有必要洗净的电容器,洗净时,必须确认以下内容:

- a) 洗净剂污染管理(电导率,PH值,比重,水分等);
- b) 洗净后,不能保管在洗净液环境中及密闭容器中,要采用(最高使用温度以下的)热风干燥印刷电路板及电容器,使之不残留洗净液成份。

(6) 不使用含卤素的固定剂,树脂涂层剂。

(7) 使用固定剂,涂层剂,请确认以下内容:

- a) 电路板与电容器之间,不能残留焊接残渣及污垢;
- b) 固定剂,涂层剂吸附前,尽可能不残留洗净成份,进行干燥处理,使印刷孔不堵塞。

(8) 螺栓产品安装,竖直安装时,压力阀朝上,横向安装时,保证压力阀或正极端子朝上。

3、组装使用

(1) 组装使用中,电容器的端子间不要直接接触,另外,不要让导体物质引起正负极短路。

(2) 请确认所安装电容器处的环境:

- a) 不要与水或油污接触或处于结露状态;
- b) 不要让曝光,O₃,紫外线及放射线直接照射到电容器上;
- c) 不要处于充满有害气体环境(硫化氢,亚硫酸,亚硝酸,氯水CL₂等);
- d) 震动及冲击不要超过样本或规格说明书中规定。

4、保守点检

工厂企事业用的电容器,必须定期点检,定期点检项目包括外观检查及性能的测试。

5、意外情况

(1) 组装过程中,如电容防爆阀打开,请切断组装主电源或拔下电源插头。

(2) 电容器防爆阀动作时,因有超过100℃高温气体喷出,脸不要接近,喷出气体进入眼睛时,立即用水清洗眼睛. 不要尝电容器的电解液,电解液 溅到皮肤上时,用肥皂清洗。

6、熏蒸处理

当组装电容器的电子产品出口到海外时,用溴化钾等卤化物进行熏蒸处理,因此方法可能会产生因卤素离子而引起的腐蚀反应,请务必小心;熏蒸时,熏蒸液不能直接接触电子产品,同时有必要进行充分干燥处理,估计有熏蒸液附着及干燥不充分时,有必要先查询一下安全性。

7、储存条件

(1) 在温度为5-30℃,湿度为75%以下的室内储存。

(2) 不要保存在组装使用中禁用的环境及同等条件下。

8、报废情况

废弃的电容器,可任选下面一种方法进行处理:

- (1) 電容器上开孔或压碎后焚烧。
- (2) 電容器不焚烧时,交給专职废品回收人员进行处理。

Part Number System (产品编码)

| | | | | | | | | | | | | | | | | | | | | |
|--------|---|------------|---|------|---|---------|---|-----------|----|------|----|--------|----|-------|----|-------|----|--------|----|----|
| 1 | 2 | 3 | 4 | 5 | 6 | 7 | 8 | 9 | 10 | 11 | 12 | 13 | 14 | 15 | 16 | 17 | 18 | 19 | 20 | 21 |
| SERIES | | CAPCITANCE | | TOL. | | VOLTAGE | | CASE SIZE | | TYPE | | SLEEVE | | COLOR | | SHAPE | | OTHERS | | |

| Series | | Cap (MFD) | Code | Tolerance | Code | Voltage | Code | Case Size | | Feature Code | | Background | Code | Special |
|--------|----|-----------|------|-----------|------|---------|------|-----------|------|-----------------|------|--------------------|------|---------------------|
| | | | | | | | | Liameten | Code | | | | | |
| LG | LR | 0.1 | 104 | ±5% | J | 004 | 4 | 3 | B | Bulk | RRO | Black | H | No special |
| ER | PG | 0.22 | 224 | ±10% | K | 6R3 | 6.3 | 4 | C | PCB Termial | | Green | L | Other trademark |
| BR | VG | 0.33 | 334 | ±15% | L | 008 | 8 | 5 | D | Ammo Taping | | Violet | Z | Ø8 F=2.5mm |
| VT | VZ | 0.47 | 474 | ±20% | M | 010 | 10 | 6.3 | E | 2.0mm Pitch | T20 | Light purple | | |
| SM | SX | 1 | 105 | ±30% | N | 016 | 16 | 8 | F | 2.5mm Pitch | T25 | Navy blue | S | |
| KS | KF | 2.2 | 225 | -40% | W | 025 | 25 | 10 | G | 3.5mm Pitch | T35 | Sky blue | T | Finite height |
| GM | KM | 3.3 | 335 | 0 | | 035 | 35 | 13 | J | 5.0mm Pitch | T50 | Coffee | K | Special voltage |
| GS | EF | 4.7 | 475 | -20% | A | 050 | 50 | 16 | K | Lead Cut & Form | | Orange red | | Special capacitance |
| ZF | GR | 10 | 106 | 0 | | 063 | 63 | 18 | L | C-Type | CXX | Transparent blue | M | |
| LF | GF | 22 | 226 | -20% | C | 080 | 80 | 22 | N | E-Type | EXX | Transparent yellow | Y | |
| EL | AL | 33 | 336 | 10% | | 100 | 100 | 25 | O | V-Type | VXX | Printing color | | |
| KL | HL | 47 | 476 | -20% | X | 120 | 120 | 30 | P | Q-Type | QXX | Black | 1 | |
| FL | GL | 100 | 107 | 40% | | 160 | 160 | 35 | Q | P-Type | PXX | White | 2 | |
| ML | ZL | 220 | 227 | -10% | V | 200 | 200 | 40 | R | W-Type | WXX | Silvery | 3 | |
| PL | RL | 330 | 337 | 20% | | 220 | 220 | 51 | S | K-Type | KXX | Golden | 4 | |
| LM | LK | 470 | 477 | 0 | R | 250 | 250 | 63.5 | T | H-Type | HXX | | | |
| LH | LL | 2200 | 228 | 20% | | 315 | 315 | 76 | U | Y-Type | YXX | | | |
| NM | NS | 22000 | 229 | 0 | I | 350 | 350 | 90 | X | | | | | |
| NP | NH | 33000 | 339 | 50% | | 400 | 400 | Len. (mm) | Code | | | | | |
| BP | PZ | 47000 | 479 | | | 420 | 420 | 05 | 5 | | | | | |
| MZ | FZ | 100000 | 10T | | | 450 | 450 | 07 | 7 | Sleeve Material | Code | Rubber Shape | Code | |
| LZ | PF | 150000 | 15T | | | 500 | 500 | 09 | 9 | PET | E | Plane | F | |
| AP | PE | 220000 | 22T | | | 550 | 550 | 10 | 10 | PVC | V | Convex | T | |
| LS | LP | 330000 | 33T | | | 600 | 600 | 11 | 11 | | | Snap-in | S | |
| FP | PN | 1000000 | 10M | | | | | 12 | 12 | | | V-chip | V | |
| MN | FN | 2200000 | 22M | | | | | 13 | 13 | | | | | |
| UN | | 3300000 | 33M | | | | | 14 | 14 | | | | | |
| | | | | | | | | 15 | 15 | | | | | |
| | | | | | | | | 16 | 16 | | | | | |
| | | | | | | | | 17 | 17 | | | | | |
| | | | | | | | | 20 | 20 | | | | | |
| | | | | | | | | 21 | 21 | | | | | |
| | | | | | | | | 25 | 25 | | | | | |
| | | | | | | | | 30 | 30 | | | | | |
| | | | | | | | | 35 | 35 | | | | | |
| | | | | | | | | 40 | 40 | | | | | |
| | | | | | | | | 45 | 45 | | | | | |
| | | | | | | | | 50 | 50 | | | | | |
| | | | | | | | | 55 | 55 | | | | | |
| | | | | | | | | 60 | 60 | | | | | |

GR Series

+105°C, High Ripple Current (高纹波), Low Impedance (低阻抗品)

FEATURES

- 1、 Low Impedance for high frequency.
- 2、 Life time: 2000~4000 hours at 105°C.

| SPECIFICATIONS | | | | | | | | | | |
|---|--|------------------------|-------|-------|---|------|-----|------|------|--|
| Item | Performance Characteristics | | | | | | | | | |
| Operation Temperature Range | -40 to +105°C | | | | | | | | | |
| Rated Working Voltage Range | 6.3to 100V | | | | | | | | | |
| Nominal Capacitance Range | 2.2 to 4700μF | | | | | | | | | |
| Capacitance Tolerance | ±20%(120Hz,+20°C) | | | | | | | | | |
| Leakage Current | $L \leq 0.01CV$ or $3(\mu A)$ Whichever is greater measured after 2 minutes application of rated working voltage at +20 °C | | | | | | | | | |
| tan δ (120Hz,+20°C) | Working Voltage(v) | 6.3 | 10 | 16 | 25 | 35 | 50 | 63 | 100 | |
| | tan δ(max) | 0.22 | 0.19 | 0.16 | 0.14 | 0.12 | 0.1 | 0.09 | 0.08 | |
| For capacitance value>1000μF ,add 0.02 per another 1000μF | | | | | | | | | | |
| Low Temperature Characteristics | Impedance ratio max. at 120 HZ | | | | | | | | | |
| | Working Voltage(V) | 6.3 | 10 | 16 | 25 | 35 | 50 | 63 | 100 | |
| | Z-25°C/Z+20°C | 4 | 3 | 2 | 2 | 2 | 2 | 2 | 2 | |
| Z-40°C/Z+20°C | 8 | 6 | 4 | 3 | 3 | 3 | 3 | 3 | | |
| High Temperature Loading | Test conditions Duration: | | | | Post test requirements at +20°C Leakage current : ≤Initial specified value Cap.change : within ±25% of initial measured value Tan δ : ≤150% of initial specified value | | | | | |
| | ΦD | 5-6.3 | 8-10 | 13-16 | | | | | | |
| | Load life | 2000H | 3000H | 4000H | | | | | | |
| | Ambient temp. | : +105°C | | | | | | | | |
| Shelf Life | Test conditions Duration : 1000 hours Ambient temp : +105°C Applied voltage :(None) | | | | Post test requirements at +20°C Same limits for high temperature loading. | | | | | |
| | Other | JIS C-5101 (IEC 60384) | | | | | | | | |

CASE SIZE TABLE

| ΦD | 5 | 6.3 | 8(L<20) | 8 (L≥20) | 10 | 12.5 | 16 |
|----|------------|-----|---------|------------|-----|------|-----|
| F | 2 | 2.5 | 3.5 | | 5 | 5 | 7.5 |
| Φd | 0.5 | | | 0.6 | 0.6 | | 0.8 |
| α | (L<20) 1.5 | | | (L≥20) 2.0 | | | |
| β | (D<20) 0.5 | | | (D≥20)1.0 | | | |

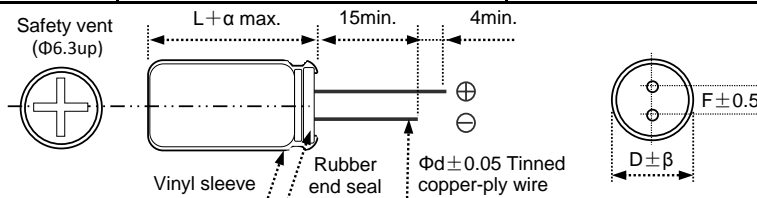

RIPPLE CURRENT MULTIPLIER

Frequency coefficient

| Cap(μF) | 120Hz | 1k Hz | 10k Hz | 100k Hz |
|-----------|-------|-------|--------|---------|
| ~180 | 0.4 | 0.75 | 0.9 | 1.0 |
| 220~560 | 0.5 | 0.85 | 0.94 | 1.0 |
| 680~1800 | 0.6 | 0.87 | 0.95 | 1.0 |
| 2200~3900 | 0.75 | 0.9 | 0.95 | 1.0 |
| 4700 | 0.85 | 0.95 | 0.98 | 1.0 |

电解电容器检查表

TEST REPORT FOR ELEC CAPACITORS

客户料号:

| | | | | | | | |
|--------------|-----------|---------------------|------------------|------------|-------------|------------|------------|
| 系列 Series | GR | 规格 Specification | 1000uF10v | 尺寸 Size | 8*12 | 数量 QTY. | pcs |
|--------------|-----------|---------------------|------------------|------------|-------------|------------|------------|

1、测试仪器: LCR METER 测试仪、漏电流测试仪

2、产品尺寸图示:

| | | |
|--|---------|-----------------|
| | 项目 | 单位 (mm) |
| | 直径 D | 8 |
| | 高度 L | 12 |
| | 脚距 F | 3.5 |
| | CP线直径 d | 0.5±0.05 |
| | α | 1.5 |
| | β | 0.5 |

3、样品特性测试数据如下表:

[测试温度: 25 °C、湿度: 32 %]

| NO. | Cap 静电容量(120Hz) | D.F 损失角 | L.C.漏电流 | E.S.R 串联等效阻抗 or Z值 |
|----------------|--|-------------------------|---------------------------------------|------------------------------|
| | Tolerance: <u>-20~+20</u> % 800 ~ 1200 (uF) | <u>120</u> Hz ≤ 0.19 | <u>10</u> V <u>2</u> 分钟 ≤ 100 (uA) | <u>100k</u> Hz ≤ 0.13 (Ω) |
| 1 | 913.0 | 0.072 | 13.0 | 0.070 |
| 2 | 912.0 | 0.070 | 14.0 | 0.072 |
| 3 | 914.0 | 0.071 | 15.0 | 0.007 |
| 4 | 912.0 | 0.073 | 13.0 | 0.072 |
| 5 | 914.0 | 0.070 | 14.0 | 0.070 |
| 6 | 912.0 | 0.071 | 13.0 | 0.073 |
| 7 | 914.0 | 0.073 | 14.0 | 0.072 |
| 8 | 915.0 | 0.070 | 12.0 | 0.072 |
| 9 | 913.0 | 0.071 | 13.0 | 0.073 |
| 10 | 914.0 | 0.072 | 14.0 | 0.075 |
| Max. | 915.0 | 0.073 | 15.0 | 0.075 |
| Min. | 912.0 | 0.070 | 12.0 | 0.007 |
| 平均值 | 913.3 | 0.071 | 13.5 | 0.066 |
| 判定 Decision | PASS | PASS | PASS | PASS |

1. Scope 适用范围：

This specification applies to aluminum electrolytic capacitor , used in electronic equipment .
本说明对于用电子仪器设备进行检测之铝电解电容器 适用.

2. Electrical characteristics 电气特性：

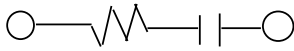
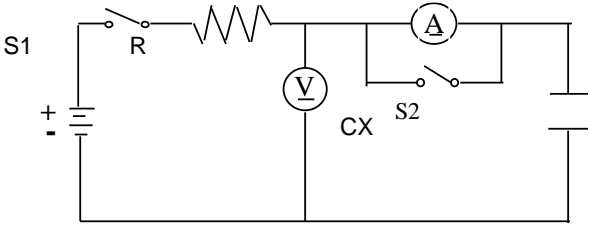
| NO. | ITEM 项目 | TEST METHOD 测试方法 | SPECIFICATION 规格 | | | | | | | | | | | | | | | |
|---------|-------------------------------------|---|--|----------------|-------------------|---|-------------|------------|---|-----------------------|---------|---|-------------|------------|---|-------------|---------|---|
| 2.1 | Rated voltage 额定电压 | | Voltage range 、 capacitance range, see specification of this series. 电压、容量范围请看该系列之规格说明. | | | | | | | | | | | | | | | |
| 2.2 | Capacitance 静电容量 | 1. Measuring frequency : 120 ± 12Hz 测定频率 2. Measuring voltage : ≤ 0.5Vrms + 0.5 ~ 2.0VDC 测定电压 | | | | | | | | | | | | | | | | |
| 2.3 | Dissipation factor 散逸因素 (损失角) | 3. Measurement circuit :  | | | | | | | | | | | | | | | | |
| 2.4 | Leakage current 泄漏电流 | DC leakage current shall be measured after 1~2 minutes application of the DC rated working voltage through the 1000 Ω resistor at 20°C. 在20 °C通过1000Ω的电阻施加直流工作电压1~2分钟后测定直流泄漏电流.  R : 1000 ± 100Ω S1 : Swich 开关 A : DC current meter S2 : Swich for protect of current meter 直流电流计 直流电流计的保护开关 V : DC voltage meter CX : Testing capacitor 直流电压计 测试电容 | Dissipation factor 、 leakage current, see specification of this series. 损失角、泄漏电流请看该系列之规格说明. | | | | | | | | | | | | | | | |
| 2.5 | Temperature characteristics 温度特性 | <table border="1"> <thead> <tr> <th>STEP 步骤</th> <th>TEMPERATURE 温度</th> <th>STORAGE TIME 放置时间</th> </tr> </thead> <tbody> <tr> <td>1</td> <td>20°C ± 2 °C</td> <td>30 minutes</td> </tr> <tr> <td>2</td> <td>-40°C or -25°C ± 3 °C</td> <td>2 hours</td> </tr> <tr> <td>3</td> <td>20°C ± 2 °C</td> <td>15 minutes</td> </tr> <tr> <td>4</td> <td>105°C ± 2°C</td> <td>2 hours</td> </tr> </tbody> </table> <p>Step 1. Measure the capacitance and impedance. 测定静电容量及阻抗 (Z r0) . (Z , 20°C , 120Hz ± 10%)</p> <p>Step 2. Measure the impedance at thermal balance after 2 hours. 达到热平衡2小时后测定阻抗 (Zr) . (Z , -40°C or -25 °C , 120Hz ± 10%)</p> <p>Step 4. Measure the capacitance and leakage current at thermal balance after 2 hours. 达到热平衡2小时后测定静电容量及漏电流 .</p> | STEP 步骤 | TEMPERATURE 温度 | STORAGE TIME 放置时间 | 1 | 20°C ± 2 °C | 30 minutes | 2 | -40°C or -25°C ± 3 °C | 2 hours | 3 | 20°C ± 2 °C | 15 minutes | 4 | 105°C ± 2°C | 2 hours | <p>Step 2. Impedance ratio (Zr / Z r0) less than specified value. 阻抗比：低于规定值 .</p> <p>Step 4 Capacitance change : within ± 20% of the initial measured value. 静电容量变化：最初测定值的 ± 20%以内. Leakage current : Less than 10 times of initial specified value . 泄漏电漏: 初期规格值的10倍以下 .</p> |
| STEP 步骤 | TEMPERATURE 温度 | STORAGE TIME 放置时间 | | | | | | | | | | | | | | | | |
| 1 | 20°C ± 2 °C | 30 minutes | | | | | | | | | | | | | | | | |
| 2 | -40°C or -25°C ± 3 °C | 2 hours | | | | | | | | | | | | | | | | |
| 3 | 20°C ± 2 °C | 15 minutes | | | | | | | | | | | | | | | | |
| 4 | 105°C ± 2°C | 2 hours | | | | | | | | | | | | | | | | |

| No. | ITEM 项目 | TEST METHOD 测试方法 | SPECIFICATION 规格 |
|-----|---|---|--|
| 2.6 | Surge test 浪涌(突波)试验 | Rated surge voltage shall be applied (switch on) for 30 ± 5 seconds and then shall be applied (switch off) with discharge for 5 ± 0.5 min at room temperature . This cycle shall be repeated for 1000 cycles . Duration of one cycle is 6 ± 0.5 minutes . 在常温下施加 (合上开关) 额定涌浪电压 30 ± 5 秒, 然后停止施加 (断开开关) 涌浪电压并且放电 5 ± 0.5 分钟. 这个循环要重复 1000 次 . 以 6 ± 0.5 分钟为一个循环周期 . | ① $\Delta C/C_0$ 在 $\pm 15\%$ 以内. ② $DF \leq 2$ 倍SPEC.或产品目录要求 ③ $ILC \leq$ 初始规定值 |
| 2.7 | MAXIMUM APPLICABLE RIPPLE CURRENT 高温最大纹波电流负荷试验 | The maximum A.C.current having frequency of 120Hz (or 100K Hz) which can be applied to the capacitor at Max. temperature $\pm 2^\circ C$ continuously. Peak voltage not to exceed rated D.C.voltage. 在120Hz(or 100K Hz) 频率条件下, 以电容器最高使用温度下, 施加最大的允许纹波电流.施加的AC及DC偏压不能超过DC电压. | ① $\Delta C/C_0$: 见SPEC.或产品目录 ② $DF \leq 2$ 倍SPEC.或产品目录要求 ③ $ILC \leq$ 初始规定值 注:与高温负荷判定标准一致 |

3. Mechanical characteristics 机械特性 :

| No. | ITEM 项目 | TEST METHOD 测试方法 | SPECIFICATION 规格 | | | | | | | | | | | | | | | | | | | | | | | | | | |
|--|-----------------------|--|---------------------|-------------|-----------|---------------------|-----------|-----|-----|-----|--------|------|-----------|-----|--------|-------------|-----------|---------------------|-----------|------|-----|-----|--|-------------------|------------------|-----|---------|-----|--|
| 3.1 | Lead strength 端子强度 | <p>(A) Tensile strength 拉伸强度 :</p> <p>wire lead terminal 导针型 :</p> <table border="1"> <tr> <td>d (mm)</td> <td>≤ 0.45</td> <td>0.5 ~ 0.8</td> <td>$0.8 < d \leq 1.25$</td> </tr> <tr> <td>load (Kg)</td> <td>0.5</td> <td>1.0</td> <td>2.0</td> </tr> </table> <p>snap-in terminal 尖脚型 :</p> <table border="1"> <tr> <td>d (mm)</td> <td>尖脚端子</td> </tr> <tr> <td>load (Kg)</td> <td>2.0</td> </tr> </table> <p>The capacitor shall withstand the constant tensile force specified between the body and each lead for 10 seconds without damage either mechanical or electrical. 电容器各端子要承受规定的荷重 10 秒, 不能有电气或机械特性上的损伤.</p> <p>(B) Bending strength 弯曲强度 :</p> <p>wire lead terminal 导针型 :</p> <table border="1"> <tr> <td>d (mm)</td> <td>≤ 0.45</td> <td>0.5 ~ 0.8</td> <td>$0.8 < d \leq 1.25$</td> </tr> <tr> <td>load (Kg)</td> <td>0.25</td> <td>0.5</td> <td>1.0</td> </tr> </table> <p>snap-in terminal 尖脚型 :</p> <table border="1"> <tr> <td>cross section area of terminal 端子截面积 (mm²)</td> <td>force 拉伸力 (Kg)</td> </tr> <tr> <td>$0.5 < S \leq 1$</td> <td>1.0</td> </tr> <tr> <td>$S > 1$</td> <td>2.5</td> </tr> </table> <p>With the capacitor in a vertical position apply the load specified axially to each lead . The capacitor shall be rotated slowly from the vertical to the horizontal position , back to the vertical position . The 90° in the opposite direction and back the original position . Performance of capacitor shall not have changed and leads shall be undamaged . 给在竖直位置的电容器的每一端子以轴方向施加规定荷重, 慢慢将电容器由竖直位置转至水平位置, 然后向相反方向弯曲 90°, 再回到原来位置. 电容器性能不能有变化及端子不能有损伤.</p> | d (mm) | ≤ 0.45 | 0.5 ~ 0.8 | $0.8 < d \leq 1.25$ | load (Kg) | 0.5 | 1.0 | 2.0 | d (mm) | 尖脚端子 | load (Kg) | 2.0 | d (mm) | ≤ 0.45 | 0.5 ~ 0.8 | $0.8 < d \leq 1.25$ | load (Kg) | 0.25 | 0.5 | 1.0 | cross section area of terminal 端子截面积 (mm ²) | force 拉伸力 (Kg) | $0.5 < S \leq 1$ | 1.0 | $S > 1$ | 2.5 | <p>When the capacitance is measured, there shall be no intermittent contacts, or open- or short- circuiting. 测定静电容量时, 不能有接触不良, 开路或短路。</p> <p>There shall be no such mechanical damage as terminal damage etc. 不能有如端子受损之类的机械特性上的损伤。</p> |
| d (mm) | ≤ 0.45 | 0.5 ~ 0.8 | $0.8 < d \leq 1.25$ | | | | | | | | | | | | | | | | | | | | | | | | | | |
| load (Kg) | 0.5 | 1.0 | 2.0 | | | | | | | | | | | | | | | | | | | | | | | | | | |
| d (mm) | 尖脚端子 | | | | | | | | | | | | | | | | | | | | | | | | | | | | |
| load (Kg) | 2.0 | | | | | | | | | | | | | | | | | | | | | | | | | | | | |
| d (mm) | ≤ 0.45 | 0.5 ~ 0.8 | $0.8 < d \leq 1.25$ | | | | | | | | | | | | | | | | | | | | | | | | | | |
| load (Kg) | 0.25 | 0.5 | 1.0 | | | | | | | | | | | | | | | | | | | | | | | | | | |
| cross section area of terminal 端子截面积 (mm ²) | force 拉伸力 (Kg) | | | | | | | | | | | | | | | | | | | | | | | | | | | | |
| $0.5 < S \leq 1$ | 1.0 | | | | | | | | | | | | | | | | | | | | | | | | | | | | |
| $S > 1$ | 2.5 | | | | | | | | | | | | | | | | | | | | | | | | | | | | |

| No. | ITEM 项目 | TEST METHOD 测试方法 | SPECIFICATION 规格 |
|-----|-----------------------------|---|---|
| 3.2 | Vibration resistance 耐振性 | <p>The frequency of the vibration shall vary uniformly within the range 10 to 55 Hz with the amplitude of 1.5 mm , completing the cycle in the internal of one minute .</p> <p>The capacitor shall be securely mounted by its leads with hold the body of capacitor .</p> <p>The capacitor shall be vibrated in three mutually perpendicular directions for a period of 2 hours in each direction .</p> <p>振动频率要均匀, 范围为 10 Hz, 到 55 Hz, 振幅为 1.5 mm , 在 1 分钟内完成该循环 .</p> <p>电容器将由端子牢固地固定 .</p> <p>电容器会被向三个互相垂直的方向每个方向振动 2 小时 .</p> | <p>Capacitance : no unsteady . 静电容量 : 稳定 .</p> <p>Appearance : no abnormal . 外观 : 无异常 .</p> <p>① Capacitance change : within $\pm 5\%$ of initial measured value . 容量变化 : 最初测得值的 $\pm 5\%$ 之内 .</p> <p>② $DF \leq$ 同SPEC.要求</p> <p>③ $ILC \leq$ 初始规定值</p> |
| 3.3 | Solderability 焊锡性 | <p>The leads are dipped in the solder bath of Sn at $245 \pm 5^\circ\text{C}$ for 3 ± 0.5 seconds . The dipping depth should be set at 1.5 ~ 2.0 mm .</p> <p>端子浸没在 $245 \pm 5^\circ\text{C}$ 的锡焊液中 3 ± 0.5 秒 . 浸没深度设定为 1.5 ~ 2.0 mm .</p> | <p>The solder alloy shall cover the 95% or more the dipped lead's area .</p> <p>锡液要覆盖导针浸入表面积 的 95% 以上 .</p> |

4. Reliability 信赖度 .

| No. | ITEM 项目 | TEST METHOD 测试方法 | SPECIFICATION 规格 |
|-----|------------------------------------|--|--|
| 4.1 | Soldering heat resistance 焊锡耐热性 | <p>The leads immerse in the solder bath of Sn at $260 \pm 5^\circ\text{C}$ for 10 ± 1 seconds until a distance of 1.5 ~ 2mm from the case .</p> <p>导针在 $260 \pm 5^\circ\text{C}$ 的锡焊液中浸没至离本体 1.5 ~ 2 mm 的地方 10 ± 1 秒 .</p> | <p>No damage or leakage of electrolyte . 无损伤或电解液漏出 .</p> <p>Capacitance change : within $\pm 10\%$ of the initial measured value . 容量变化 : 最初测定值的 $\pm 5\%$ 以内 .</p> <p>Tan δ : less than specified value . 损失角 : 低于规定值 .</p> <p>Leakage current : less than specified value . 泄漏电流 : 低于规定值 .</p> |
| 4.2 | Damp heat (steady state) 稳态湿热 | <p>Subject the capacitors to $85 \pm 2^\circ\text{C}$ and 85% to 95% relative humidity for 500+24/0 hours .</p> <p>电容器在 $85 \pm 2^\circ\text{C}$ 及相对湿度 85% 到 95% 的条件下经历 500 (-0~+24) 小时 .</p> | <p>Capacitance change : within $\pm 10\%$ of the initial measured value . 容量变化 : 最初测定值的 $\pm 15\%$ 以内 .</p> <p>Tan δ : less than 120% of the initial specified value . 损失角 : 低于1.2倍规定值 .</p> <p>Leakage current : less than specified value . 泄漏电流 : 低于规定值 .</p> |

| NO. | ITEM 项目 | TEST METHOD 测试方法 | SPECIFICATION 规格 | | | | | | | | | | | | | | |
|---|------------------------------------|--|--|----------------------------|-----------------------|---------------|---------------------------------------|--------------|---|-------------|---|------------|---|--------------|------------------------|---|---|
| 4.3 | Load life 高温负荷 | <p>After X hours continuous application of DC rated working voltage at Max. temperature $\pm 2^{\circ}\text{C}$.</p> <p>Measurements shall be performed after 2 hours exposed at room temperature .</p> <p>在最高使用温度 $\pm 2^{\circ}\text{C}$ 环境当中连续施加直流定格电压 X 小时。</p> <p>(X: see specification of this series. 见该系列规格说明 .)</p> | <p>Standard of judgement is according to requirement of this series .</p> <p>判定标准依该系列要求 .</p> | | | | | | | | | | | | | | |
| 4.4 | Shelf life 高温无负荷 | <p>After storage for Y hours at temperature $\pm 2^{\circ}\text{C}$(See specification of this series) without voltage application , the measurements shall meet the following limits .</p> <p>Measurements shall be performed after exposed for 1 to 2 hrs at room temperature after application of DC rated voltage to the capacitor for Z minutes .</p> <p>在 目录书规定的温度环境当中不施加直流定格电压放置 Y 小时后 , 按以下条件测试 .</p> <p>测试在室温露置 1 到 2 小时 , 施加直流定格电压 Z 分锺后进行。</p> <p>(Y . Z : see specification of this series. 见该系列规格说明 .)</p> | | | | | | | | | | | | | | | |
| 4.5 | Storage at low temperature 低温贮存 | <p>The capacitor shall be stored at the lowest($\pm 3^{\circ}\text{C}$) temperature for 1000+24/0 hours , during which time no voltage shall be applied .</p> <p>And then the capacitor shall be subjected to standard atmospheric conditions for 16 hours or more , after which measurements shall be made .</p> <p>电容器在最低允许温度($\pm 3^{\circ}\text{C}$) 环境当中贮存1000+24/0 小时, 其间不施加电压 .</p> <p>之后, 在标准大气压中露置 16 小时以上, 然后进行测试 .</p> | <p>Capacitance change : within $\pm 10\%$ of the initial value .</p> <p>容量变化 : 最初值的 $\pm 10\%$ 以内 .</p> <p>Tan δ : less than specified value .</p> <p>损耗角 : 低于规定值 .</p> <p>Leakage current : less than specified value .</p> <p>泄漏电流 : 低于规定值 .</p> <p>Appearance : no abnormal .</p> <p>外观 : 无异常 .</p> | | | | | | | | | | | | | | |
| 4.6 | Pressure relief 防爆试验 | <p>AC test 交流试验 : (此条件只适用于≥ 08产品)</p> <p>Applied voltage : AC voltage not exceeding 0.7 times of the rated direct voltage or 250 V AC whichever is the lower .</p> <p>施加电压 : 不超过定格电压 0.7 倍的交流电压或低于交流电压 250 V 的任意电压 .</p> <p>Frequency 频率 : 50 Hz or 60 Hz .</p> <p>Series resistor : refer to the table below .</p> <p>串联阻抗 : 参照下表 .</p> <table border="1" data-bbox="523 1765 1088 2078"> <thead> <tr> <th>Capacitance (C) 容 量</th> <th>Series resistor 串 联 阻 抗</th> </tr> </thead> <tbody> <tr> <td>$C \leq 1\mu\text{F}$</td> <td>1000 Ω</td> </tr> <tr> <td>$1\mu\text{F} < C \leq 10\mu\text{F}$</td> <td>100 Ω</td> </tr> <tr> <td>$10\mu\text{F} < C \leq 100\mu\text{F}$</td> <td>10 Ω</td> </tr> <tr> <td>$100\mu\text{F} < C \leq 1000\mu\text{F}$</td> <td>1 Ω</td> </tr> <tr> <td>$1000\mu\text{F} < C \leq 10000\mu\text{F}$</td> <td>0.1 Ω</td> </tr> <tr> <td>$10000\mu\text{F} < C$</td> <td>*</td> </tr> </tbody> </table> <p>* Resistance is equivalent to a half impedance by test frequency . 相当于试验频率的一半阻抗值 .</p> | Capacitance (C) 容 量 | Series resistor 串 联 阻 抗 | $C \leq 1\mu\text{F}$ | 1000 Ω | $1\mu\text{F} < C \leq 10\mu\text{F}$ | 100 Ω | $10\mu\text{F} < C \leq 100\mu\text{F}$ | 10 Ω | $100\mu\text{F} < C \leq 1000\mu\text{F}$ | 1 Ω | $1000\mu\text{F} < C \leq 10000\mu\text{F}$ | 0.1 Ω | $10000\mu\text{F} < C$ | * | <p>AC test circuit 交流试验回路</p>  <p> \sim : AC power 交流电源 S : Switch 开关 V : AC voltage meter 交流电压计 A : AC current meter 交流电流计 R : protection resistor 保护电阻 Cx : testing capacitor 供试电容器 </p> |
| Capacitance (C) 容 量 | Series resistor 串 联 阻 抗 | | | | | | | | | | | | | | | | |
| $C \leq 1\mu\text{F}$ | 1000 Ω | | | | | | | | | | | | | | | | |
| $1\mu\text{F} < C \leq 10\mu\text{F}$ | 100 Ω | | | | | | | | | | | | | | | | |
| $10\mu\text{F} < C \leq 100\mu\text{F}$ | 10 Ω | | | | | | | | | | | | | | | | |
| $100\mu\text{F} < C \leq 1000\mu\text{F}$ | 1 Ω | | | | | | | | | | | | | | | | |
| $1000\mu\text{F} < C \leq 10000\mu\text{F}$ | 0.1 Ω | | | | | | | | | | | | | | | | |
| $10000\mu\text{F} < C$ | * | | | | | | | | | | | | | | | | |

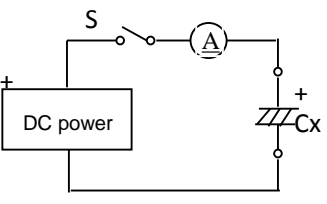
| No. | ITEM 项目 | TEST METHOD 测试方法 | SPECIFICATION 规格 |
|-----|-------------|---|--|
| 4.6 | sure relief | <p>DC test :</p> <p>Send the following electricities while applying the inverse voltage .</p> <p>where case size (D) :</p> <p>D \leq 22.4 mm : 1 A d.c. max D > 22.4 mm : 10 A d.c. max</p> <p>Note : 1. This requirement applies to capacitors with a diameter of 8 mm or more . 2. When the pressure relief divice does not open even 30 minutes after commencement of test , the test may be ended .</p> | <p>DC test circuit</p>  <p>S : Swich (A) : DC current meter Cx : testing capacitor</p> <p>The pressure relief divice shall open in such a way as to avoid any dange of fire or explosion of capacitor elements (terminal and metal foil etc) or cover .</p> |

5. 外观Marking :

产品外套管印刷内容如下

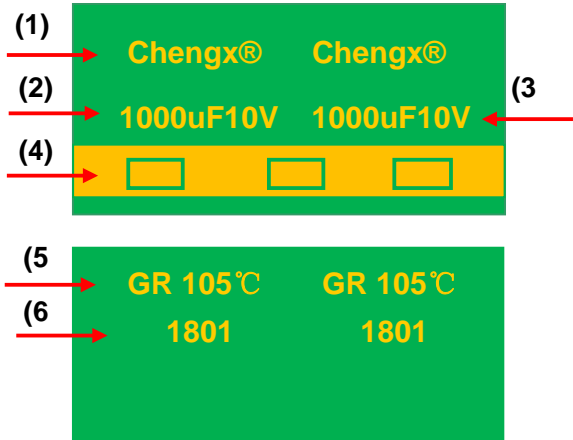
| 序号 | 项目内容说明 | 图示 |
|-----|--------|--|
| (1) | 商标 |  |
| (2) | 标称静电容量 | |
| (3) | 额定工作电压 | |
| (4) | 负极线标示 | |
| (5) | 系列、温度 | |
| (6) | 周期、材质 | |

6.包装数量标准:

| 产品外形尺寸 D×L (mm) | 小袋数量 (只/袋) | 散装/切脚 (袋/内箱) | 散装/切脚内箱 (KPCS) | 散装/切脚大箱 (KPCS) (KPCS) | 备注 |
|--------------------|---------------|-----------------|-------------------|--------------------------|----|
| φ3*5 | 2000+3 | 25 | 50 | 100 | |
| φ4*5-7、φ5*5 | 1000+2 | 50 | 50 | 100 | |
| φ6.3*5、φ5*7 | 1000+2 | 30 | 30 | 60 | |
| φ6.3*7、φ5*11/12 | 1000+2 | 25 | 25 | 50 | |
| φ6.3*11、φ8*5 | 1000+1 | 20 | 20 | 40 | |
| φ6.3*12 | 1000+1 | 16 | 16 | 32 | |
| φ8*7 | 1000+1 | 18 | 18 | 36 | |
| φ8*9 | 500+1 | 30 | 15 | 30 | |
| φ8*11/12 | 500+1 | 25/25 | 12.5/12.5 | 25/25 | |
| φ8*14 | 500+1 | 20 | 10 | 20 | |
| φ8*16-20 | 500+1 | 16 | 8 | 16 | |
| φ10*13 | 500+1 | 15 | 7.5 | 15 | |
| φ10*15 | 400 | 15 | 6 | 12 | |
| φ10*17-20 | 200 | 25 | 5 | 10 | |
| φ10*25 | 200 | 20 | 4 | 8 | |
| φ10*30 | 100 | 30 | 3 | 6 | |
| φ13*17-21 | 200 | 15 | 3 | 6 | |
| φ13*25 | 200 | 12 | 2.4 | 4.8 | |
| φ13*30 | 100 | 20 | 2 | 4 | |
| φ16*18-22 | 100 | 20 | 2 | 4 | |
| φ16*25 | 100 | 15 | 1.5 | 3 | |
| φ16*30 | 100 | 12 | 1.2 | 2.4 | |
| φ16*35 | 50 | 20 | 1 | 2 | |
| φ18*27 | 100 | 10 | 1 | 2 | |
| φ18*30 | 50 | 15 | 0.75 | 1.5 | |
| φ18*36 | 50 | 15 | 0.75 | 1.5 | |
| φ18*40 | 50 | 10 | 0.5 | 1.5 | |
| φ18*50 | 25 | 15 | 0.375 | 0.75 | |
| φ22*30 | 50 | 10 | 0.5 | 1 | |
| φ22*35 | 50 | 10 | 0.5 | 1 | |
| φ22*40 | 50 | 10 | 0.5 | 1 | |
| φ25*25 | 50 | 10 | 0.5 | 1 | |
| φ25*30 | 50 | 10 | 0.5 | 1 | |

备注: 包装外箱L480mm*W320mm*H320mm

内箱L300mm*W230mm*H300mm

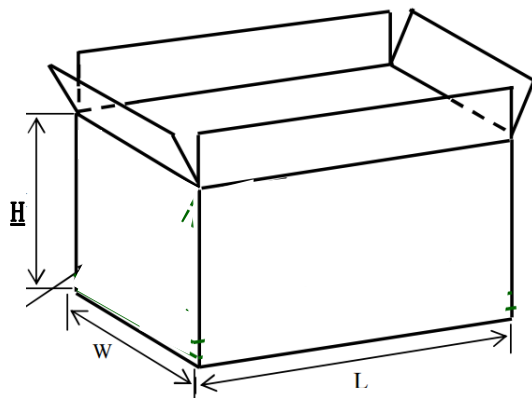

外箱

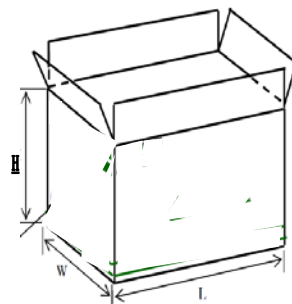

内箱

X-ON Electronics

Largest Supplier of Electrical and Electronic Components

Click to view similar products for [Aluminium Electrolytic Capacitors - Radial Leaded](#) category:

Click to view products by [Chengxing](#) manufacturer:

Other Similar products are found below :

[NRELS102M35V16X16C.140LLF](#) [ESRG160ETC100MD07D](#) [227RZS050M](#) [335CKR250M](#) [476CKH100MSA](#) [477CKR100M](#)
[107CKR010M](#) [107CKH063MSA](#) [RJH-25V222MI9#](#) [RJH-35V221MG5#](#) [B43827A1106M8](#) [RJH-50V221MH6#](#) [EKYA500ELL470MF11D](#)
[B41022A5686M6](#) [ESRG250ELL101MH09D](#) [EKMA160EC3101MF07D](#) [RJB-10V471MG3#](#) [ESMG160ETD221MF11D](#)
[EKZH160ETD152MJ20S](#) [RJH-35V122MJ6#](#) [EGXF630ELL621ML20S](#) [RBD-25V100KE3#N](#) [EKMA350ELL100ME07D](#)
[ESMG160ETD101ME11D](#) [ELXY100ETD102MJ20S](#) [EGXF500ELL561ML15S](#) [EKMG350ETD471MJ16S](#) [35YXA330MEFC10X12.5](#)
[RXW471M1ESA-0815](#) [ELXZ630ELL221MJ25S](#) [ERR1HM1R0D11OT](#) [LPE681M30060FVA](#) [LPL471M22030FVA](#) [HFE221M25030FVA](#)
[LKMD1401H221MF](#) [B41888G6108M000](#) [EKMA160ETD470MF07D](#) [UHW1J102MHD6](#) [EKMG500ETD221MJC5S](#) [LKMK2502W101MF](#)
[LKMD1401H181MF](#) [LKMI2502G820MF](#) [LKMJ2001J122MF](#) [LKML2501C472MF](#) [LKMJ4002C681MF](#) [450MXH330MEFCSN25X45](#)
[450MXK330MA2RFC22X50](#) [63ZLH560MEFCG412.5X30](#) [ELH2DM331O25KT](#) [ELH2DM471P30KT](#)