

Chip Bead ABUP Series

**Automotive
AEC-Q200**

RoHS Compliant
Halogen Free
REACH Compliant



Noise
Suppression

Shield

Multilayer

Ferrite

High
Current

Part Numbering

A	BU P	00	160808	600	Y	00
Grade	Series Name	Control Code	Dimensions Code (mm)	Impedance (Ω)	Tolerance	Internal Code
			100505 1.0x0.5x0.5	300 30	Y ±25%	
			160808 1.6x0.8x0.8	800 80		
			201209 2.0x1.25x0.9	121 120		
			321611 3.2x1.6x1.1			

This specification applies to Multilayer Chip ferrite Bead for Automotive Electronics based on AEC-Q200 except for Power train and Safety.

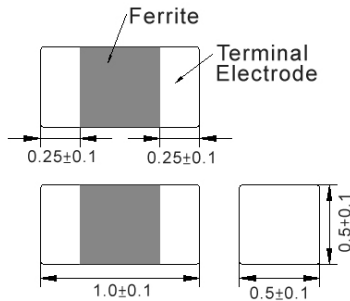
ABUP00100505 Type
■ Dimensions

unit:mm

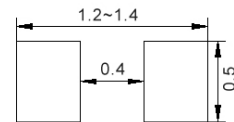
■ Recommended Land Pattern

unit:mm

■ Electrical Characteristics

Part No.	Impedance (Ω)	Test Freq.	RDC (Ω)Max.	Rated Current (mA)Max.
ABUP00100505300Y00	30	100 MHz,200 mV	0.022	3000
ABUP00100505330Y00	33	100 MHz,200 mV	0.022	3000
ABUP00100505600Y00	60	100 MHz,200 mV	0.032	2500
ABUP00100505800Y00	80	100 MHz,200 mV	0.038	2300
ABUP00100505121Y00	120	100 MHz,200 mV	0.055	2000

Note: When ordering, please specify tolerance code. Tolerance: Y=±25%

1. Operating temperature range - 55°C ~ 125°C
2. Rate Current : Applied the current to coils, the temperature rise shall not be more than 30°C
3. Measure Equipment:
 Z: HP4291A
 RDC: HP4338B or CHEN HWA 502

ABUP00100505 Type

Characteristics Graph

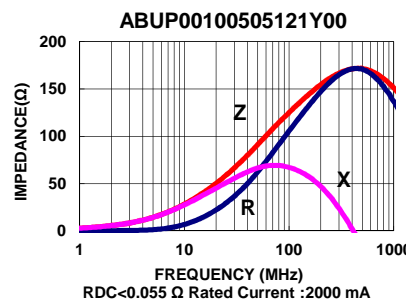
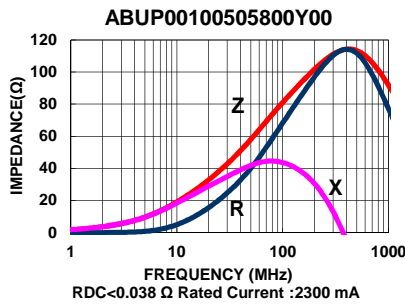
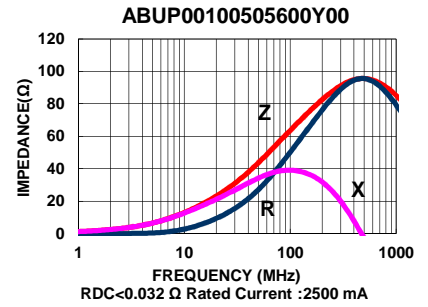
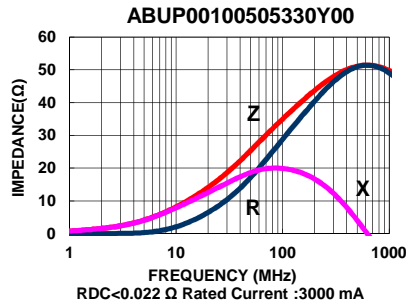
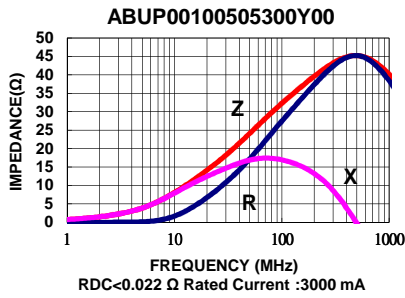

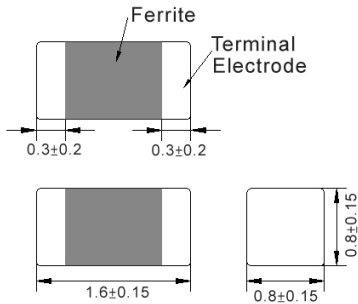
ABUP00160808 Type
■ Dimensions

unit:mm

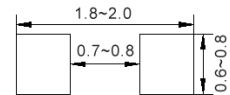
■ Recommended Land Pattern

unit:mm

■ Electrical Characteristics

Part No.	Impedance (Ω)	Test Freq.	RDC (Ω)Max.	Rated Current (mA)Max.
ABUP00160808300Y00	30	100 MHz,200 mV	0.015	4500
ABUP00160808101Y00	100	100 MHz,200 mV	0.030	3000
ABUP00160808121Y00	120	100 MHz,200 mV	0.030	3000
ABUP00160808181Y00	180	100 MHz,200 mV	0.050	2000
ABUP00160808221Y00	220	100 MHz,200 mV	0.040	2500

Note: When ordering, please specify tolerance code. Tolerance: Y=±25%

1. Operating temperature range - 55°C ~ 125°C
2. Rate Current : Applied the current to coils, the temperature rise shall not be more than 30°C
3. Measure Equipment:
 Z: HP4291A
 RDC: HP4338B or CHEN HWA 502

ABUP00160808 Type

Characteristics Graph

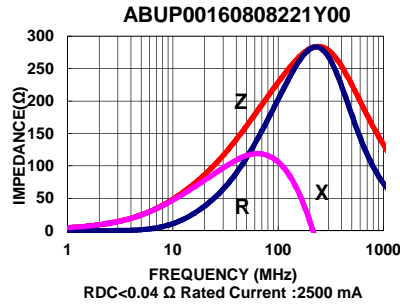
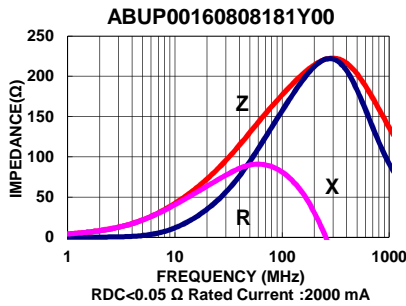
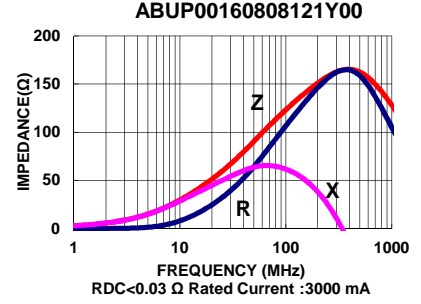
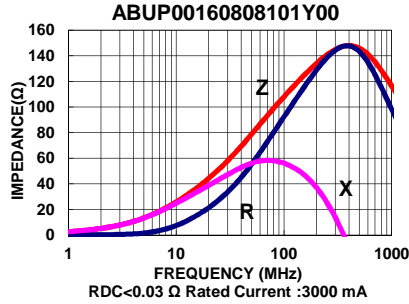
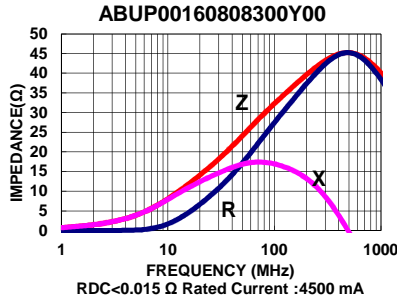

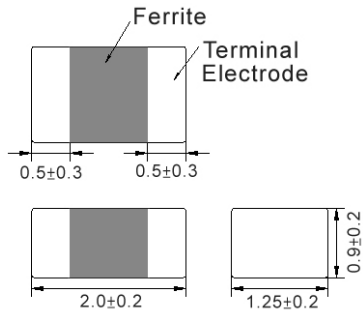
ABUP00201209 Type
■ Dimensions

unit:mm

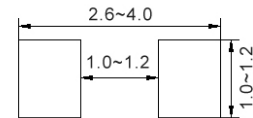
■ Recommended Land Pattern

unit:mm

■ Electrical Characteristics

Part No.	Impedance (Ω)	Test Freq.	RDC (Ω)Max.	Rated Current (mA)Max.
ABUP00201209220Y00	22	100 MHz,200 mV	0.012	6000
ABUP00201209300Y00	30	100 MHz,200 mV	0.012	6000
ABUP00201209500Y00	50	100 MHz,200 mV	0.015	6000
ABUP00201209600Y00	60	100 MHz,200 mV	0.018	6000
ABUP00201209800Y00	80	100 MHz,200 mV	0.020	6000
ABUP00201209101Y00	100	100 MHz,200 mV	0.020	5000
ABUP00201209121Y00	120	100 MHz,200 mV	0.020	5000
ABUP00201209201Y00	200	100 MHz,200 mV	0.040	3000
ABUP00201209221Y00	220	100 MHz,200 mV	0.040	3000
ABUP00201209301Y00	300	100 MHz,200 mV	0.050	3000
ABUP00201209331Y00	330	100 MHz,200 mV	0.050	3000

Note: When ordering, please specify tolerance code. Tolerance: Y=±25%

1. Operating temperature range - 55°C ~ 125°C
2. Rate Current : Applied the current to coils, the temperature rise shall not be more than 30°C
3. Measure Equipment:
 Z: HP4291A
 RDC: HP4338B or CHEN HWA 502

ABUP00201209 Type

Characteristics Graph

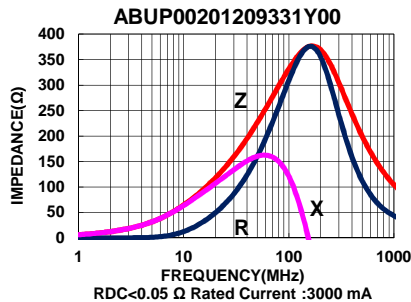
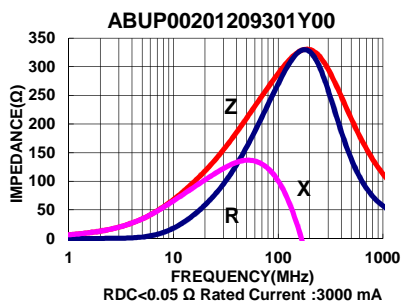
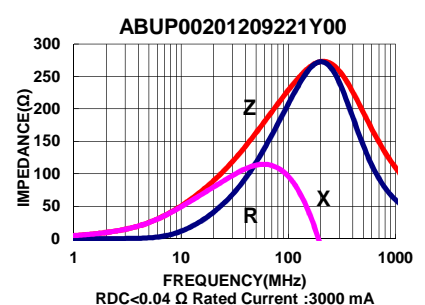
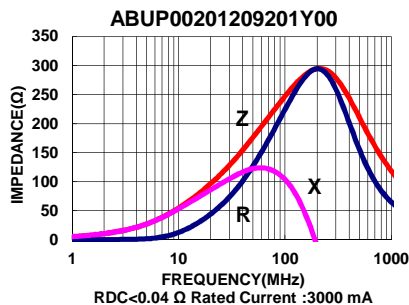
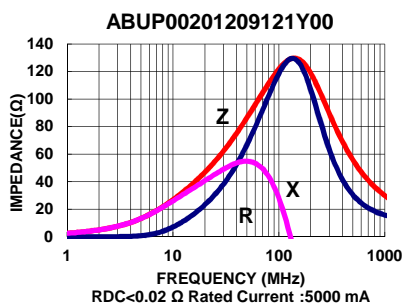
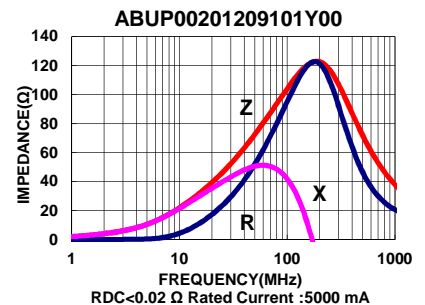
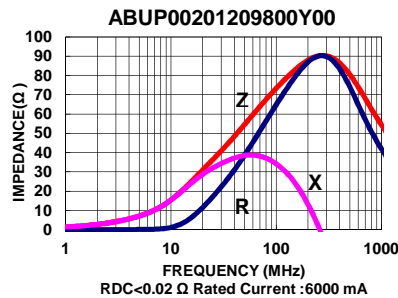
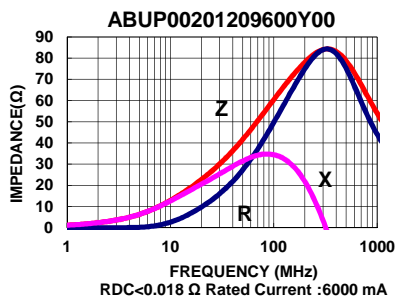
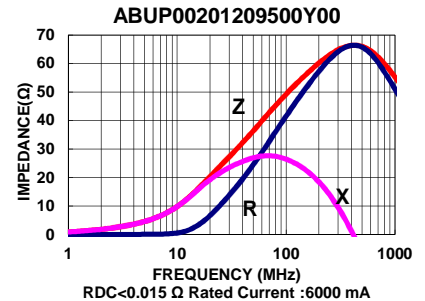
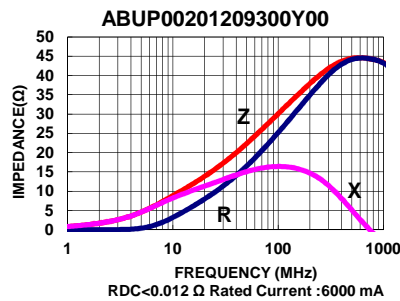
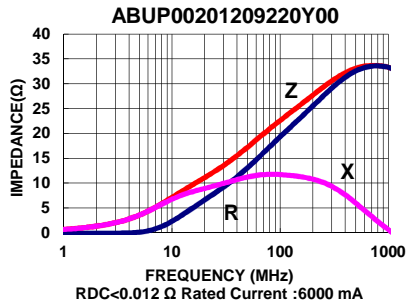

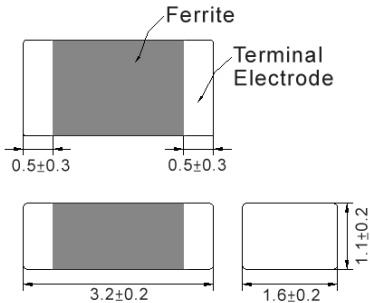
ABUP00321611 Type
■ Dimensions

unit:mm

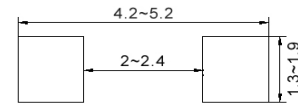
■ Recommended Land Pattern

unit:mm

■ Electrical Characteristics

Part No.	Impedance (Ω)	Test Freq.	RDC (Ω)Max.	Rated Current (mA)Max.
ABUP00321611300Y00	30	100 MHz,200 mV	0.012	6000
ABUP00321611600Y00	60	100 MHz,200 mV	0.012	6000
ABUP00321611800Y00	80	100 MHz,200 mV	0.012	6000
ABUP00321611101Y00	100	100 MHz,200 mV	0.012	6000
ABUP00321611121Y00	120	100 MHz,200 mV	0.012	6000
ABUP00321611151Y00	150	100 MHz,200 mV	0.020	4500
ABUP00321611181Y00	180	100 MHz,200 mV	0.020	4500
ABUP00321611221Y00	220	100 MHz,200 mV	0.020	4500

Note: When ordering, please specify tolerance code. Tolerance: Y=±25%

1. Operating temperature range - 55°C ~ 125°C
2. Rate Current : Applied the current to coils, the temperature rise shall not be more than 30°C
3. Measure Equipment:
 Z: HP4291A
 RDC: HP4338B or CHEN HWA 502

ABUP00321611 Type

Characteristics Graph

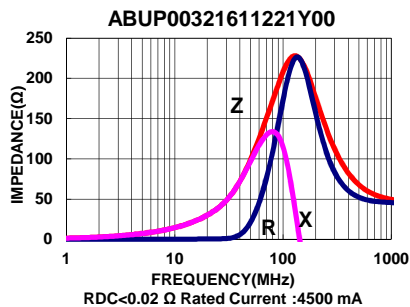
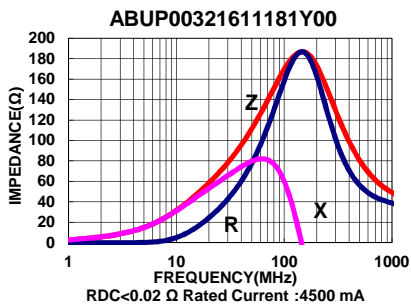
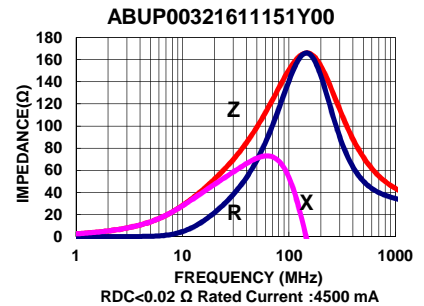
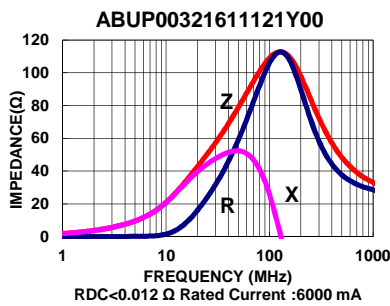
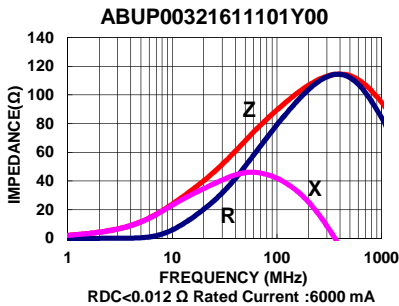
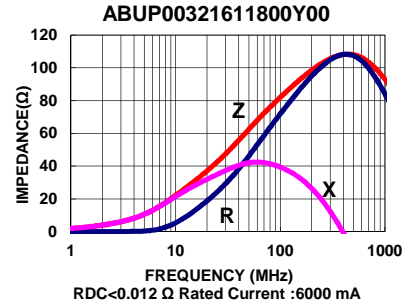
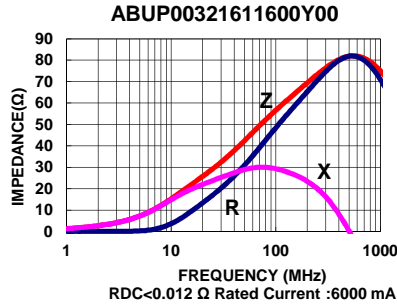
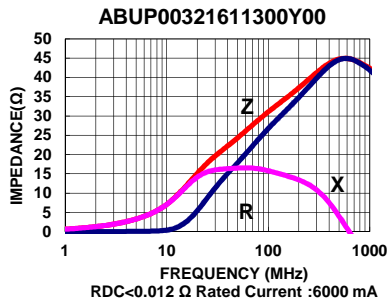

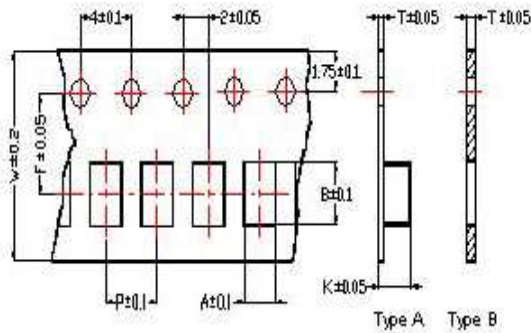
■ Packaging
Tape Dimensions

Tape Material

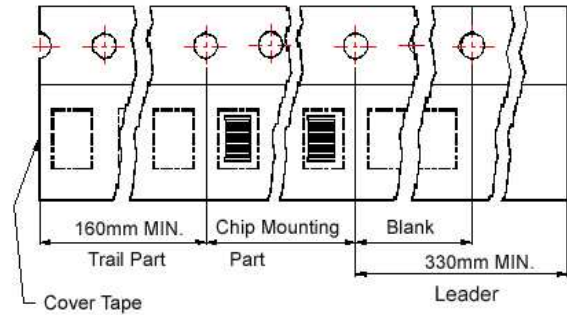
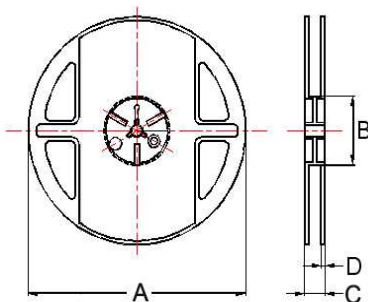
Carrier Tape: Polycarbonate (Tape A)
 Carrier Tape: Paper (Tape B)
 Cover Tape: Polystyrene

Reel Dimensions

Dimensions in mm

TYPE	Tape Dimensions								Reel Dimensions				Quantity
	A	B	T	W	P	F	K	Tape	A	B	C	D	PCS / Reel
ABUP00100505	0.62	1.12	0.60	8	2	3.5	-	B	178	60	12	2	10000
ABUP00160808	1.05	1.85	0.95	8	4	3.5	-	B	178	60	12	2	4000
ABUP00201209	1.50	2.30	0.97	8	4	3.5	-	B	178	60	12	2	4000
ABUP00321611	1.88	3.50	0.22	8	4	3.5	1.27	A	178	60	12	2	3000

X-ON Electronics

Largest Supplier of Electrical and Electronic Components

Click to view similar products for [Ferrite Beads](#) category:

Click to view products by [Chilisin](#) manufacturer:

Other Similar products are found below :

[CZB1JGTTD152P](#) [CZB2AFTTD800P](#) [CZB2AGTTD121P](#) [PE-0402FB121ST](#) [AB 3X2X3SM](#) [DER0705-2.2](#) [NCB0603R301TR050F](#)
[NCB0805A320TR050F](#) [NCB-H1206B680TR300F](#) [CZB1JGTTD221P](#) [CZB1JGTTD600P](#) [CZB2AGTTD301P](#) [CZB2BFTTE301P](#)
[CZB2BFTTE601P](#) [4221R-1](#) [EMI0805R-600](#) [SBY100505T-100Y-N](#) [NCB-GH0402D121TR060F](#) [NCB0402P301TR005F](#)
[NCB0603R152TR030F](#) [NCB0805A121TR050F](#) [NCB0805A301TR070F](#) [NCB3312K900TR500F](#) [NCB-H0805A221TR300F](#)
[NCB0402P221TR030F](#) [NCB0805A102TR040F](#) [NCB1806E151TR020F](#) [NCB-H0402P100TR200F](#) [NCB-H0603R121TR300F](#) [NCB-](#)
[H0805A220TR600F](#) [NCB-H1206B601TR200F](#) [CZB1JGTTD202P](#) [CBH160808W221T](#) [WLBD1005HCU330TL](#) [WLBD2012HCU121TH](#)
[WLBD2012HCU221TH](#) [WQBD1608HCU121TH](#) [WLBD1608K2U252TB](#) [VLU0810-102KBC12](#) [WLBD1608K2U800TP](#) [BMB2A0080AN4](#)
[SZ1608F470TF](#) [FBSHC0805-331-302R](#) [HFJ100505T-601Y-N](#) [HFY100505T-221Y-N](#) [PBY201209T-110Y-N](#) [SBY060303T-121Y-N](#)
[BBPY00160808301Y00](#) [SBY100505T-750Y-N](#) [BBPY00100505102Y00](#)