



ISO9001 ISO14001 IATF16949 **CHILISIN ELECTRONICS CORP.**
RoHS & Halogen Free & REACH Compliance.

SPECIFICATION FOR APPROVAL

Customer : 國益

Customer P/N: _____

Drawing No : _____

Quantity : 0 Pcs. Date : 2021/06/04

Chilisin P/N : BDHE00252012Series-VI

SPECIFICATION ACCEPTED BY:	
COMPONENT ENGINEER	
ELECTRICAL ENGINEER	
MECHANICAL ENGINEER	
APPROVED	
REJECTED	

<p>奇力新電子股份有限公司 Chilisin Electronics Corp No. 29, Alley 301, Tehhsin Rd., Hukou, Hsinchu 303, Taiwan TEL : +886-3- 599-2646 FAX : +886-3- 599-9176 E-mail : sales@chilisin.com http : //www.chilisin.com</p>	<p>東莞奇力新電子(東莞廠)有限公司 Chilisin Electronics (Dongguan) Co., Ltd. No. 78, Puxing Rd., Yuliangwei Administration Area, Qingxi Town, Dongguan City, Guangdong, China TEL : +86-769-8773-0251~3 FAX : +86-769-8773-0232 E-mail : cect@chilisin.com</p>
<p>奇力新電子(越南廠)有限公司 Chilisin Electronics (Vietnam) Limited No 143 - 145, Road No 10, VSIP Hai Phong, Lap Le Commune, Thuy Nguyen Dist, Haiphong City, Vietnam Tel : 84-316 255 688 Fax : 84-316 255 689 E-mail : sales@chilisin.com</p>	<p>奇力新電子(湖南廠)有限公司 HuNan Chilisin Electronics Technology Co., Ltd No. 8, Shaziao Liangshuijing Town, Yuanling County, Huaihua City, Hunan Province 419601, China Tel : 86-745-867-5882 E-mail : cect@chilisin.com</p>

Applied by 張鈺雯 Chang.Yuwen	Checked by 張鈺雯 Chang.Yuwen	Approved by 鍾瑞民 Jacky.Chung
--------------------------------------	--------------------------------------	---------------------------------------



BDHE00252012 Series Specification

1 Scope: This specification applies to Molding power inductors

2 Part Numbering:

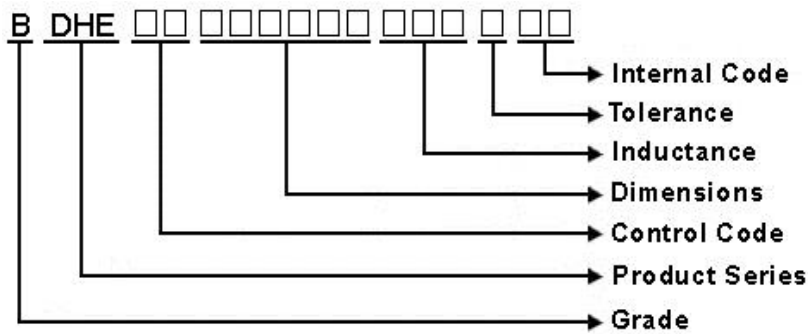

3 Rating:

Operating Temperature: - 4 0 °C ~ 1 2 5 °C(Including self - temperature rise)

Storage Temperature: - 4 0 °C ~ 1 2 5 °C(after PCB)
- 5 °C~ 3 5 °C, Humidity 4 5 %~ 8 5 %(before PCB)

4 Marking:

No Marking

5 Standard Testing Condition

	Unless otherwise specified	In case of doubt
Temperature	Ordinary Temperature(15 to 35°C)	20 to 30°C
Humidity	Ordinary Humidity(25 to 85% RH)	50 to 80 %RH

BDHE00252012 Series Specification

6 Configuration and Dimensions:

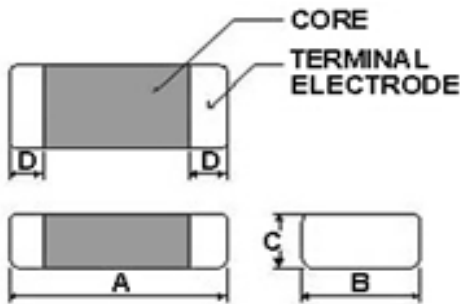

Dimensions in mm

TYPE	252012
A	2.5±0.2
B	2.0±0.2
C	1.2 Max
D	0.6±0.3

7 Electrical Characteristics:

Part No.	Inductance (uH)	Tolerance (±%)	Test Freq.	I _{rms} (A) Max.(Typ)	I _{sat} (A) Max.(Typ)	RDC(mΩ) Max.(Typ)
BDHE00252012R24MV1	0.24	20	2MHz,1V	5.7(6.7)	8.5(9.7)	16.5(11.5)
BDHE00252012R33MV1	0.33	20	2MHz,1V	5.0(5.5)	7.0(8.0)	21(16)
BDHE00252012R47MV1	0.47	20	2MHz,1V	4.2(4.6)	5.6(7.0)	26(20)
BDHE00252012R68MV1	0.68	20	2MHz,1V	3.8(4.4)	5.0(6.2)	31(25)
BDHE002520121R0MV1	1.0	20	2MHz,1V	3.6(4.1)	4.4(5.5)	42(36)
BDHE002520121R5MV1	1.5	20	2MHz,1V	2.7(3.1)	3.4(4.2)	59(52)
BDHE002520122R2MV1	2.2	20	2MHz,1V	2.5(2.9)	2.9(3.5)	86(80)

Note:

1. Operating temperature range - 40°C ~ 125°C (Including self - temperature rise)
2. I_{sat} for Inductance drop 30% from its value without current.
3. I_{rms} for a 40°C temperature rise from 25°C ambient.
4. All test data is referenced to 25°C ambient
5. Absolute maximum voltage 20VDC
6. Rated current: I_{sat} or I_{rms}, whichever is smaller

BDHE00252012 Series Specification

8 BDHE00252012 Series

8.1 Construction:

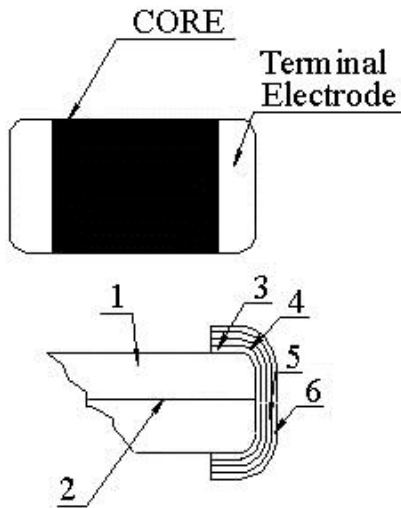

8.2 Material List:

No	Part	Material
1	Core	Metal Powder
2	Wire	Copper wire
3	Sputter/Plating	Cu
4	Silver Electrode	Ag
5	Plating	Ni
6	Plating	Sn



BDHE00252012 Series Specification

9 Reliability Of Molding power inductors

1-1.Mechanical Performance

No	Item	Specification	Test Method
1-1-1	Flexure Strength	The forces applied on the right conditions must not damage the terminal electrode and the metal body	Test device shall be soldered on the substrate Substrate Dimension: 100x40x1.6mm Deflection: 2.0mm Keeping Time: 30sec
1-1-2	Vibration	Appearance:No damage (for microscope of CASTOR MZ-45 20X) Inductance change shall be within $\pm 20\%$	Test device shall be soldered on the substrate Oscillation Frequency: 10 to 55 to 10Hz for 1min Amplitude: 1.5mm Time: 2hrs for each axis (X, Y & Z), total 6hrs
1-1-3	Resistance to Soldering Heat	Appearance: No damage More than 75% of the terminal. electrode should be covered with solder. Inductance: within $\pm 20\%$ of initial value	Pre-heating: 150°C, 1min Solder Composition: Sn/Ag3.0/Cu0.5(Pb-Free) Solder Temperature: 260 ± 5 °C Immersion Time: 10 ± 1 sec
1-1-4	Solder ability	The electrodes shall be at least 95% covered with new solder coating	Pre-heating: 150°C, 1min Solder Composition: Sn/Ag3.0/Cu0.5(Pb-Free) Solder Temperature: 245 ± 5 °C Immersion Time: 4 ± 1 sec
1-1-5	Terminal Strength Test	No split termination	Test device shall be soldered on the substrate, then apply a force in the direction of the arrow. Force : 5N Keeping Time: 10 ± 1 sec

1-2.Environmental Performance

No	Item	Specification	Test Method		
1-2-1	Temperature Cycle	Appearance: No damage Inductance: within $\pm 20\%$ of initial value	One cycle:		
			Step	Temperature (°C)	Time (min)
			1	-40 ± 3	30
			2	25 ± 2	3
			3	125 ± 3	30
4	25 ± 2	3			
Total: 100cycles			Measured after exposure in the room condition for 24hrs		
1-2-2	Humidity Resistance		Temperature: 60 ± 2 °C Relative Humidity: 90 ~ 95% / Time: 500hrs Measured after exposure in the room condition for 24hrs		
1-2-3	High Temperature Resistance		Temperature: 85 ± 3 °C Relative Humidity: 0% / Time: 500hrs Measured after exposure in the room condition for 24hrs		
1-2-4	Low Temperature Resistance		Temperature: -40 ± 3 °C Relative Humidity: 0% / Time: 500hrs Measured after exposure in the room condition for 24hrs		

BDHE00252012 Series Specification

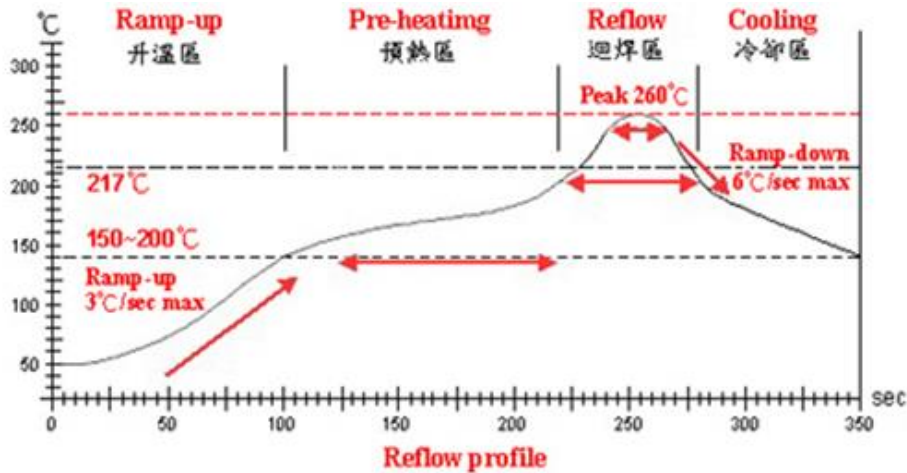

Lead-Free(LF) 標準溫度分析範圍

Refer to J-STD-020C

管制項目 Item.	升温區 Ramp-up	預熱區 Pre-heating	迴焊區 Reflow	Peak Temp	冷卻區 Cooling
溫度範圍 Temp.scope	R.T. ~150°C	150°C ~ 200°C	217°C	260±5°C	Peak Temp. ~ 150°C
標準時間 Time spec.	—	60 ~ 180 sec	60 ~ 150sec	20 ~ 40 sec	—
實際時間 Time result	—	75 ~ 100 sec	90 ~ 120sec	20 ~ 35 sec	—

NOTE :

1. Re-flow possible times : within 2 times
2. Nitrogen adopted is recommended while in re-flow

BDHE00252012 Series Specification

10 Packaging:

10.1 Packaging -Cover Tape

The force for tearing off cover tape is 10 to 100 grams in the arrow direction.

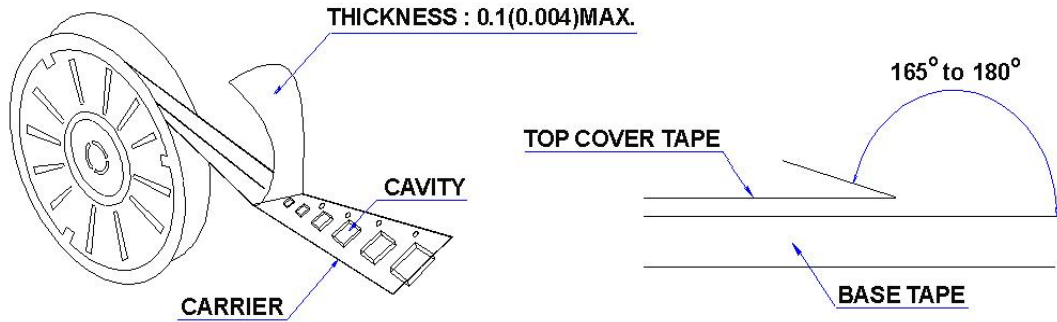

10.2 Packaging Quantity

TYPE	PCS/REEL
252012	3000

10.3 Reel Dimensions

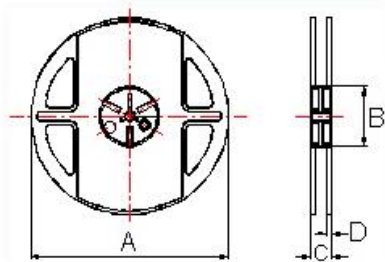

Dimensions in mm

TYPE	A	B	C	D
252012	178	60	12	1.5

BDHE00252012 Series Specification

10 Packaging:

10.4 Tape Dimensions in mm

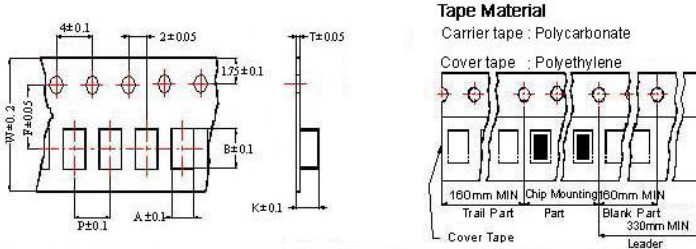

TYPE	A	B	T	W	P	F	K
252012	2.25	2.8	0.22	8	4	3.5	1.35

11 Recommended Land Pattern:

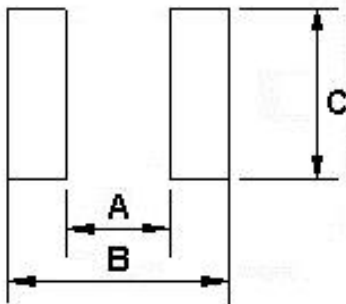

Dimensions in mm

TYPE	A	B	C
252012	1.2	2.8	2.3

12 Note:

1. Please make sure that your product has been evaluated and confirmed against your specifications when our product is mounted to your product.
2. Do not knock nor drop.
3. All the items and parameters in this product specification have been prescribed on the premise that our product is used for the purpose, under the condition and in the environment agreed upon between you and us. You are requested not to use our product deviating from such agreement.
4. Please keep the distance between transformer/coil and other components (refer to the standard IEC 950)
5. After manufacturing process, there might be slight irregular shape on the edge of the products, and it's a normal phenomenon that can be neglected
6. The moisture sensitivity level (MSL) of products is classified as level 1.

X-ON Electronics

Largest Supplier of Electrical and Electronic Components

Click to view similar products for [Fixed Inductors](#) category:

Click to view products by [Chilisin](#) manufacturer:

Other Similar products are found below :

[CR43NP-680KC](#) [CR54NP-470LC](#) [CR54NP-820KC](#) [CR54NP-8R5MC](#) [70F224AI](#) [MGDQ4-00004-P](#) [MHL1ECTTP18NJ](#) [MHQ1005P10NJ](#)
[MHQ1005P1N0S](#) [MHQ1005P2N4S](#) [MHQ1005P3N6S](#) [MHQ1005P5N1S](#) [MHQ1005P8N2J](#) [PE-51506NL](#) [PE-53601NL](#) [PE-53602NL](#) [PE-](#)
[53630NL](#) [PE-53824SNLT](#) [PE-92100NL](#) [PG0434.801NLT](#) [PG0936.113NLT](#) [9220-20](#) [9310-16](#) [PM06-2N7](#) [PM06-39NJ](#) [A01TK](#) [1206CS-](#)
[471XJ](#) [HC2LP-R47-R](#) [HC2-R47-R](#) [HC3-2R2-R](#) [HC3-R50-R](#) [HC8-1R2-R](#) [HCF1305-3R3-R](#) [1206CS-151XG](#) [RCH664NP-140L](#) [RCH664NP-](#)
[4R7M](#) [RCH8011NP-221L](#) [RCP1317NP-332L](#) [RCP1317NP-391L](#) [RCR1010NP-470M](#) [RCR110DNP-331L](#) [DH2280-4R7M](#) [DS1608C-106](#)
[ASPI-4020HI-R10M-T](#) [B10TJ](#) [B82498B3680J000](#) [ELJ-RE27NJF2](#) [1812CS-153XJ](#) [1812CS-183XJ](#) [1812CS-223XJ](#)