

## BSCY Series

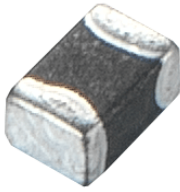

The SMD multi-layered ferrite chip inductors provide a cost-effective solution for densely packed PC board designs. BSCY series comes in 3 sizes and is suitable for low frequency applications.

### Features

- RoHS compliant
- High mounting density of compact circuit due to crosstalk elimination that results from a closed magnetic flux in a ferrite material
- Suitable for flow and re-flow soldering
- Available in 3 sizes

### Applications

- Personal computers, HDDs, other various electronic devices
- Any portable device where compact size and high mounting densities are required

### Product Identification

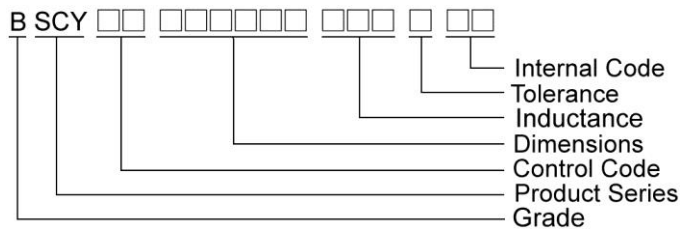

### Shape and Dimensions

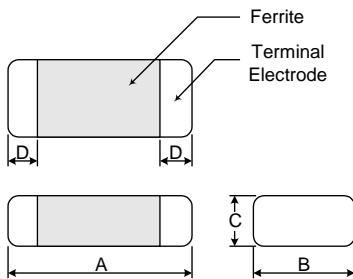

Dimensions in mm

TYPE	A	B	C	D
BSCY00160808	1.6±0.2	0.80±0.2	0.80±0.2	0.3±0.2
BSCY00201209	2.0±0.2	1.25±0.2	0.90±0.2	0.5±0.3
BSCY00201212	2.0±0.2	1.25±0.2	1.25±0.2	0.5±0.3

### Recommended Pattern

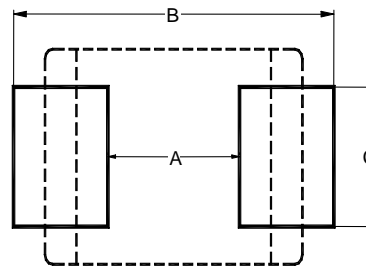

Dimensions in mm

TYPE	A	B	C
BSCL00160808	0.7 ~ 0.8	1.8 ~ 2.0	0.6 ~ 0.8
BSCL00201209	1.0 ~ 1.2	2.6 ~ 4.0	1.0 ~ 1.4
BSCL00201212	1.0 ~ 1.2	2.6 ~ 4.0	1.0 ~ 1.2

# SMD Multilayer Ferrite Chip Inductors – BSCY Series

## Electrical Characteristics

Part Number	Inductance (μH)	Tolerance (±%)	Test Frequency (MHz)	RDC (Ω) Max	Rated Current (mA) Max
BSCY001608082R2□CP	2.2	30 / 20	1	0.20	1000
BSCY001608084R7□CP	4.7	30 / 20	1	0.25	800
BSCY00160808100□CP	10	30 / 20	1	0.90	90

**Note: When ordering, please specify tolerance code. Tolerance : M=±20% , T=±30%**

- Operating temperature range - 40°C ~ 105°C(Including self - temperature rise)
- Rated Current : Applied the current to coils, the temperature rise shall not be more than 30°C
- Measure Equipment :
  - L & Q : HP4291A
  - SRF : Agilent HP8753D/Agilent E4991A
  - RDC : HP4338B or CHEN HWA 502

**Test Instruments :** Agilent E4991A Impedance / Material Analyzer

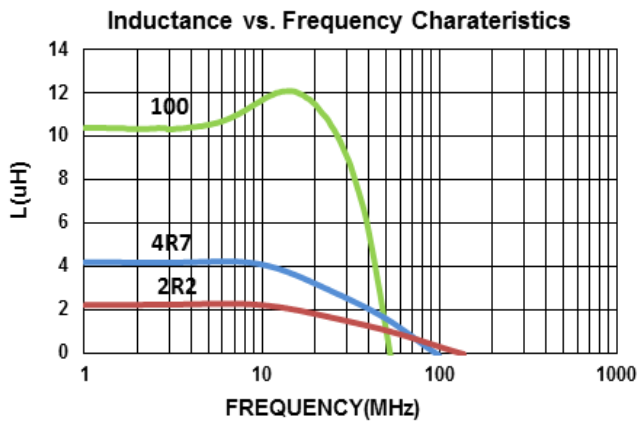

# SMD Multilayer Ferrite Chip Inductors – BSCY Series

## Electrical Characteristics

Part Number	Inductance (μH)	Tolerance (±%)	Test Frequency (MHz)	RDC (Ω) Max	Rated Current (mA) Max
BSCY002012091R0□CP	1.0	30 / 20	1	0.06	2200
BSCY002012092R2□CP	2.2	30 / 20	1	0.10	2000
BSCY002012094R7□CP	4.7	30 / 20	1	0.30	900

**Note: When ordering, please specify tolerance code. Tolerance : M=±20% , T=±30%**

- Operating temperature range - 40°C ~ 105°C (Including self - temperature rise)
- Rated Current : Applied the current to coils, the temperature rise shall not be more than 30°C
- Measure Equipment :
  - L & Q : HP4291A
  - SRF : Agilent HP8753D/Agilent E4991A
  - RDC : HP4338B or CHEN HWA 502

**Test Instruments :** Agilent E4991A Impedance / Material Analyzer

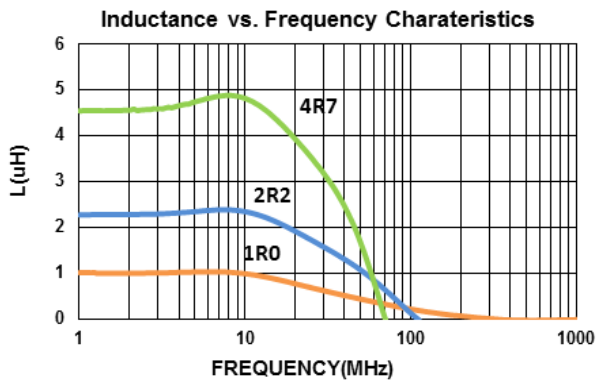

# SMD Multilayer Ferrite Chip Inductors – BSCY Series

## Electrical Characteristics

Part Number	Inductance (μH)	Tolerance (±%)	Test Frequency (MHz)	RDC (Ω) Max	Rated Current (mA) Max
BSCY00201212100□CP	10	30 / 20	1	0.50	400

**Note: When ordering, please specify tolerance code. Tolerance : M=±20% , T=±30%**

- Operating temperature range - 40°C ~ 105°C(Including self - temperature rise)
- Rated Current : Applied the current to coils, the temperature rise shall not be more than 30°C
- Measure Equipment :  
 L & Q : HP4291A  
 SRF : Agilent HP8753D/Agilent E4991A  
 RDC : HP4338B or CHEN HWA 502

**Test Instruments :** Agilent E4991A Impedance / Material Analyzer

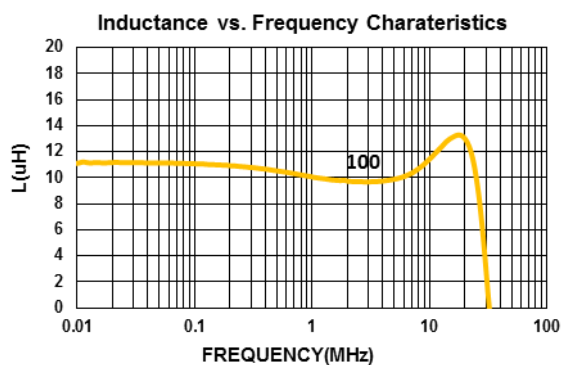

# SMD Multilayer Ferrite Chip Inductors - BSCY Series

## Packaging Specifications

### Tape Dimensions

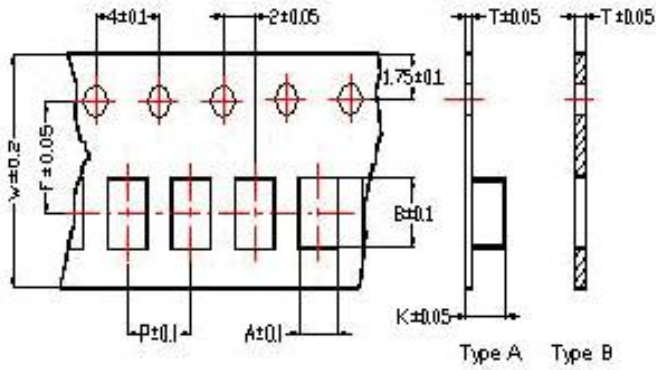

### Tape Material

Carrier Tape: Polycarbonate (Tape A)  
 Carrier Tape: Paper (Tape B)  
 Cover Tape: Polystyrene

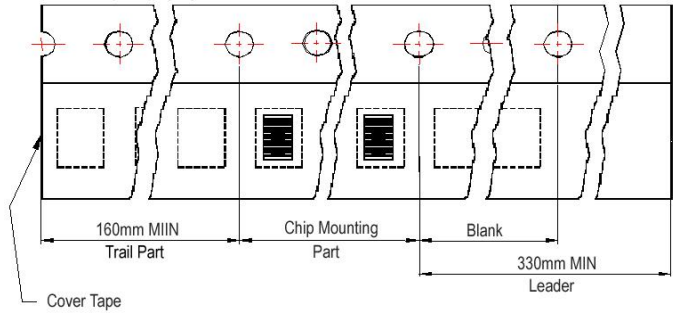

### Reel Dimensions

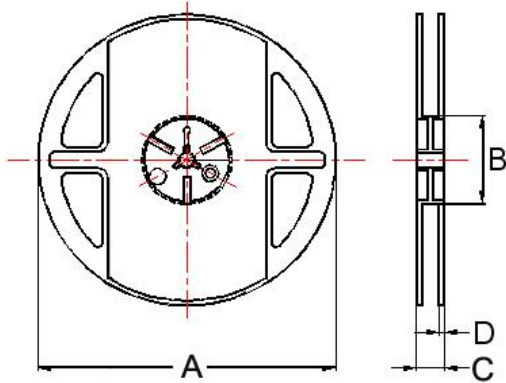

### Dimensions in mm

TYPE	Tape Dimensions								Reel Dimensions				Quantity PCS / Reel
	A	B	T	W	P	F	K	Tape	A	B	C	D	
BSCY00160808	1.05	1.85	0.95	8.0	4.0	3.5	-	B	178	60	12	1.5	4000
BSCY00201209	1.50	2.30	0.97	8.0	4.0	3.5	-	B	178	60	12	1.5	4000
BSCY00201212	1.35	2.25	0.22	8.0	4.0	3.5	1.35	A	178	60	12	1.5	3000

## X-ON Electronics

Largest Supplier of Electrical and Electronic Components

*Click to view similar products for [Fixed Inductors](#) category:*

*Click to view products by [Chilisin](#) manufacturer:*

Other Similar products are found below :

[CR32NP-100KC](#) [CR54NP-470LC](#) [70F224AI](#) [MGDQ4-00004-P](#) [MHQ1005P10NJ](#) [MHQ1005P1N0S](#) [MHQ1005P2N4S](#) [MHQ1005P3N6S](#)  
[MHQ1005P5N1S](#) [MHQ1005P8N2J](#) [PE-53601NL](#) [PE-53602NL](#) [PG0936.113NLT](#) [9220-20](#) [9310-16](#) [PM06-2N7](#) [PM06-39NJ](#) [A01TK](#)  
[1206CS-471XJ](#) [HC2-R47-R](#) [HC8-1R2-R](#) [HCF1305-3R3-R](#) [1206CS-151XG](#) [RCH664NP-140L](#) [RCH664NP-4R7M](#) [RCP1317NP-391L](#)  
[RCR110DNP-331L](#) [DH2280-4R7M](#) [DS1608C-106](#) [B10TJ](#) [B82498B3101J000](#) [ELJ-RE27NJF2](#) [1812CS-153XJ](#) [1812CS-183XJ](#) [1812CS-](#)  
[223XJ](#) [1812LS-104XJ](#) [1812LS-105XJ](#) [1812LS-124XJ](#) [1812LS-154XJ](#) [1812LS-223XJ](#) [1812LS-224XJ](#) [1812LS-563XJ](#) [1812LS-683XJ](#)  
[1812LS-824XJ](#) [NIN-FB101JTR110F](#) [NIN-FB471JTR62F](#) [NIN-FC1R5JTR220F](#) [NIN-HCR15JTRF](#) [NIN-HCR33JTRF](#) [NIN-HDR22JTRF](#)