



ISO9001 & ISO14001 & TS16949 **CHILISIN ELECTRONICS CORP.**

RoHS & Halogen Free & REACH Compliance.

SPECIFICATION FOR APPROVAL

Customer : _____

Customer P/N: _____

Drawing No : _____

Quantity : 0 Pcs. Date : 2016/04/15

Chilisin P/N : MHCHL252010A-SERIES-Q8

SPECIFICATION ACCEPTED BY:	
COMPONENT ENGINEER	
ELECTRICAL ENGINEER	
MECHANICAL ENGINEER	
APPROVED	
REJECTED	

奇力新電子股份有限公司
Chilisin Electronics Corp
No. 29, Alley 301, Tehhsin Rd.,
Hukou, Hsinchu 303, Taiwan
TEL : +886-3- 599-2646
FAX : +886-3- 599-9176
E-mail : sales@chilisin.com.tw
http : //www.chilisin.com.tw

東莞奇力新電子有限公司
Chilisin Electronics (Dongguan) Co., Ltd.
No. 78, Puxing Rd., Yuliangwei Administration
Area, Qingxi Town, Dongguan City,
Guangdong, China
TEL : +86-769-8773-0251~3
FAX : +86-769-8773-0232
E-mail : cect@chilisin.com.tw

奇力新電子(河南)有限公司
Chilisin Electronics (Henan) Co., Ltd.
XiuWu Xian, industry gathering area
JiaoZuo, Henan China
Postal Code:454350
TEL:+86-391-717-0682
FAX:+86-391-717-0666

蘇州奇益新電子有限公司
SUZHOU QI YIXIN Electronics Co., Ltd.
No.143, Song Shan Rd., Suzhou New District,
Suzhou, China
Postal Code:215129
TEL:+86-512-6841-2350
FAX:+86-512-6841-2356

Drawn by
陳瑞揚 ryan.chen

Checked by
邱明傑 Joseph.Chiu

Approved by
陳瑞揚 ryan.chen

MHCHL252010A Series Specification

1 Scope: This specification applies to Molding power inductors

2 Part Numbering:

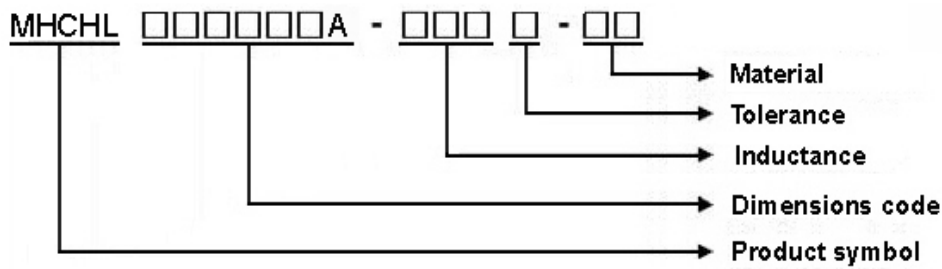

3 Rating:

Operating Temperature: $-40^{\circ}\text{C} \sim 125^{\circ}\text{C}$ (Including self - temperature rise)

Storage Temperature: $-40^{\circ}\text{C} \sim 125^{\circ}\text{C}$ (after PCB)

$-5^{\circ}\text{C} \sim 35^{\circ}\text{C}$, Humidity 45%~85% (before PCB)

4 Marking:



5 Standard Testing Condition

	Unless otherwise specified	In case of doubt
Temperature	Ordinary Temperature(15 to 35°C)	20 to 30°C
Humidity	Ordinary Humidity(25 to 85% RH)	50 to 80 %RH

MHCHL252010A Series Specification

6 Configuration and Dimensions:

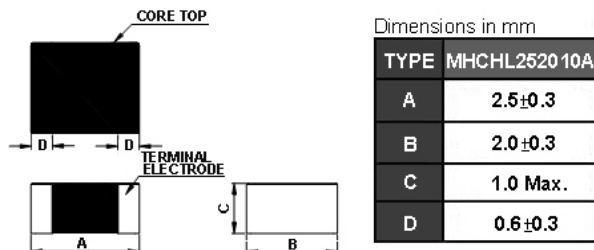

7 Electrical Characteristics:

Part No.	Inductance (uH)	Test Freq.	I _{rms} (A) Max.(Typ)	I _{sat} (A) Max.(Typ)	RDC(mΩ) Max.(Typ)	SRF (MHz)Min.	Tolerance (±%)
MHCHL252010A-R24M-Q8	0.24	2MHz,0.2V	5.5(6.5)	8.0(9.5)	18(13)	126	20
MHCHL252010A-R33M-Q8	0.33	2MHz,0.2V	4.8(5.5)	6.5(8.0)	24(18)	95	20
MHCHL252010A-R47M-Q8	0.47	2MHz,0.2V	3.9(4.5)	5.0(6.2)	35(27)	87	20
MHCHL252010A-R68M-Q8	0.68	2MHz,0.2V	3.7(4.2)	4.5(5.6)	40(32)	53	20
MHCHL252010A-1R0M-Q8	1	2MHz,0.2V	3.0(3.5)	3.7(4.6)	53(45)	41	20
MHCHL252010A-1R5M-Q8	1.5	2MHz,0.2V	2.4(2.8)	3.1(3.8)	75(68)	37	20
MHCHL252010A-2R2M-Q8	2.2	2MHz,0.2V	2.2(2.5)	2.5(3.0)	105(87)	29	20

NOTE:

1. Operating temperature range - 40°C ~ 125°C (Including self - temperature rise)
2. I_{sat} for Inductance drop 30% from its value without current.
3. I_{rms} for a 40°C temperature rise from 25°C ambient.
4. All test data is referenced to 25°C ambient

MHCHL252010A Series Specification

8 MHCHL252010A Series

8.1 Construction:

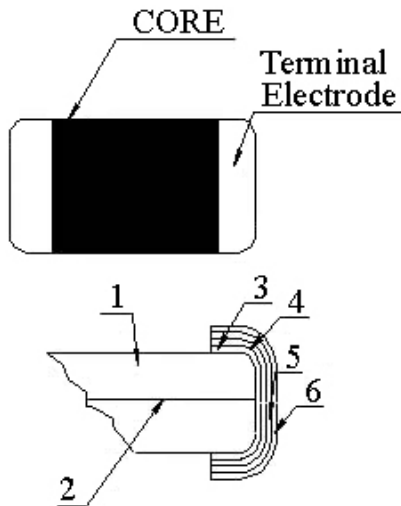

8.2 Material List:

No	Part	Material
1	Core	Metal Powder
2	Wire	Copper wire
3	Sputter/Plating	Cu
4	Silver Electrode	Ag
5	Plating	Ni
6	Plating	Sn

MHCHL252010A Series Specification

9 Reliability Of Molding power inductors

1-1.Mechanical Performance

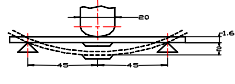
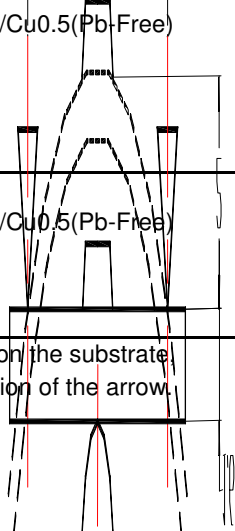
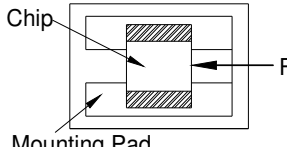
No	Item	Specification	Test Method
1-1-1	Flexure Strength	The forces applied on the right conditions must not damage the terminal electrode and the metal body	Test device shall be soldered on the substrate Substrate Dimension: 100x40x1.6mm Deflection: 2.0mm Keeping Time: 30sec 
1-1-2	Vibration	Appearance:No damage (for microscope of CASTOR MZ-45 20X) Inductance change shall be within $\pm 20\%$	Test device shall be soldered on the substrate Oscillation Frequency: 10 to 55 to 10Hz for 1min Amplitude: 1.5mm Time: 2hrs for each axis (X, Y & Z), total 6hrs
1-1-3	Resistance to Soldering Heat	Appearance: No damage More than 75% of the terminal electrode should be covered with solder. Inductance: within $\pm 20\%$ of initial value	Pre-heating: 150°C, 1min Solder Composition: Sn/Ag3.0/Cu0.5(Pb-Free) Solder Temperature: 260 ± 5 °C Immersion Time: 10 ± 1 sec 
1-1-4	Solder ability	The electrodes shall be at least 95% covered with new solder coating	Pre-heating: 150°C, 1min Solder Composition: Sn/Ag3.0/Cu0.5(Pb-Free) Solder Temperature: 245 ± 5 °C Immersion Time: 4 ± 1 sec
1-1-5	Terminal Strength Test	No split termination  Chip Mounting Pad	Test device shall be soldered on the substrate then apply a force in the direction of the arrow. Force : 5N Keeping Time: 10 ± 1 sec

1-2.Environmental Performance

No	Item	Specification	Test Method															
1-2-1	Temperature Cycle	Appearance: No damage Inductance: within $\pm 20\%$ of initial value	One cycle:															
			<table border="1"> <thead> <tr> <th>Step</th> <th>Temperature (°C)</th> <th>Time (min)</th> </tr> </thead> <tbody> <tr> <td>1</td> <td>-40± 3</td> <td>30</td> </tr> <tr> <td>2</td> <td>25± 2</td> <td>3</td> </tr> <tr> <td>3</td> <td>125± 3</td> <td>30</td> </tr> <tr> <td>4</td> <td>25± 2</td> <td>3</td> </tr> </tbody> </table>	Step	Temperature (°C)	Time (min)	1	-40 ± 3	30	2	25 ± 2	3	3	125 ± 3	30	4	25 ± 2	3
			Step	Temperature (°C)	Time (min)													
			1	-40 ± 3	30													
2	25 ± 2	3																
3	125 ± 3	30																
4	25 ± 2	3																
Total: 100cycles																		
Measured after exposure in the room condition for 24hrs																		
1-2-2	Humidity Resistance		Temperature: 60 ± 2 °C Relative Humidity: 90 ~ 95% / Time: 500hrs Measured after exposure in the room condition for 24hrs															
1-2-3	High Temperature Resistance		Temperature: 85 ± 3 °C Relative Humidity: 0% / Time: 500hrs Measured after exposure in the room condition for 24hrs															
1-2-4	Low Temperature Resistance		Temperature: -40 ± 3 °C Relative Humidity: 0% / Time: 500hrs Measured after exposure in the room condition for 24hrs															

MHCHL252010A Series Specification

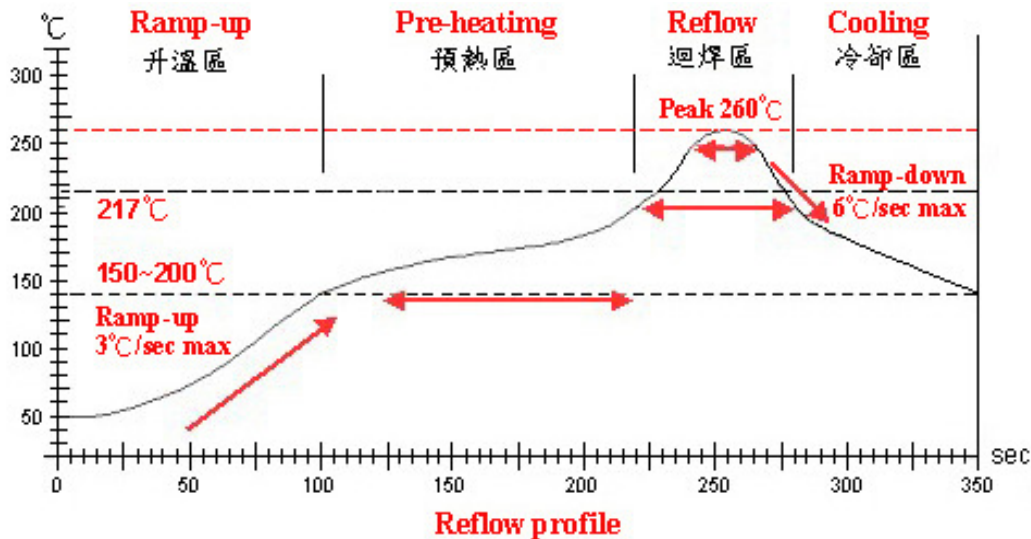

Lead-Free(LF) 標準溫度分析範圍

Refer to J-STD-020C

管制項目 Item.	升温區 Ramp-up	預熱區 Pre-heating	迴焊區 Reflow	Peak Temp	冷卻區 Cooling
溫度範圍 Temp.scope	R.T. ~ 150°C	150°C ~ 200°C	217°C	260±5°C	Peak Temp. ~ 150°C
標準時間 Time spec.	—	60 ~ 180 sec	60 ~ 150sec	20 ~ 40 sec	—
實際時間 Time result	—	75 ~ 100 sec	90 ~ 120sec	20 ~ 35 sec	—

NOTE :

1. Re-flow possible times : within 2 times
2. Nitrogen adopted is recommended while in re-flow

MHCHL252010A Series Specification

10 Packaging:

10.1 Packaging -Cover Tape

The force for tearing off cover tape is 10 to 100 grams in the arrow direction.

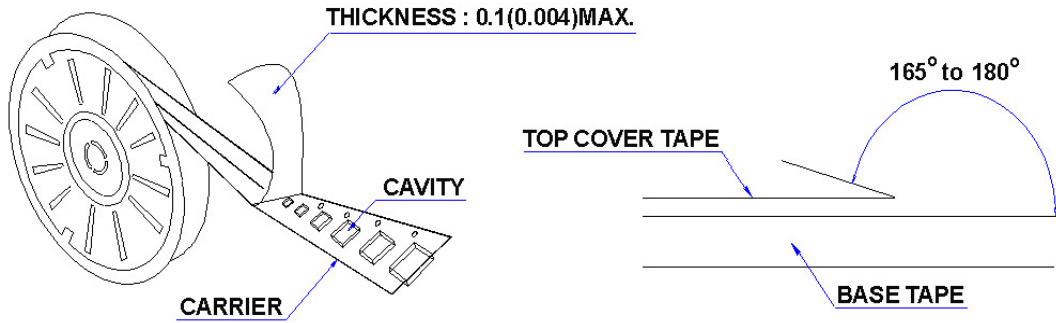

10.2 Packaging Quantity

TYPE	PCS/REEL
MHCHL252010A	3000

10.3 Reel Dimensions

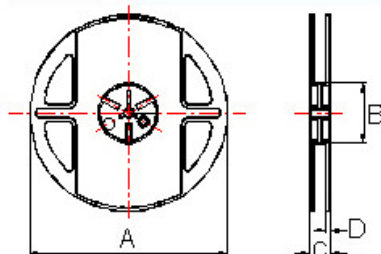

Dimensions in mm

TYPE	A	B	C	D
MHCHL252010A	178	60	12	1.5

MHCHL252010A Series Specification

10 Packaging:

10.4 Tape Dimensions in mm

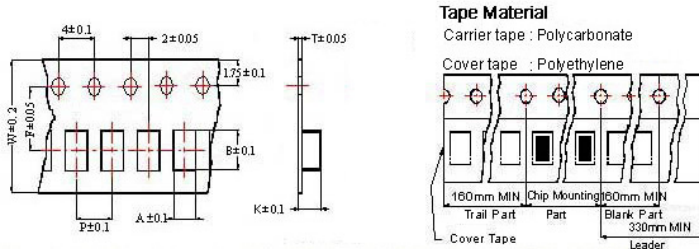

TYPE	A	B	T	W	P	F	K
MHCHL252010A	2.25	2.8	0.22	8	4	3.5	1.15

11 Recommended Land Pattern:

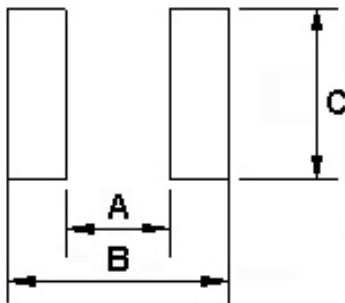

Dimensions in mm

TYPE	A	B	C
MHCHL252010A	1.2	2.8	2.3

12 Note:

- Please make sure that your product has been evaluated and confirmed against your specifications when our product is mounted to your product.
- Do not knock nor drop.
- All the items and parameters in this product specification have been prescribed on the premise that our product is used for the purpose, under the condition and in the environment agreed upon between you and us. You are requested not to use our product deviating from such agreement.
- Please keep the distance between transformer/coil and other components (refer to the standard IEC 950)
- After manufacturing process, there might be slight irregular shape on the edge of the products, and it's a normal phenomenon that can be neglected
- The moisture sensitivity level (MSL) of products is classified as level 1.

X-ON Electronics

Largest Supplier of Electrical and Electronic Components

Click to view similar products for [Fixed Inductors](#) category:

Click to view products by [Chilisin](#) manufacturer:

Other Similar products are found below :

[CR32NP-100KC](#) [CR32NP-151KC](#) [CR32NP-180KC](#) [CR32NP-181KC](#) [CR32NP-1R5MC](#) [CR32NP-390KC](#) [CR32NP-3R9MC](#) [CR32NP-680KC](#) [CR32NP-820KC](#) [CR32NP-8R2MC](#) [CR43NP-390KC](#) [CR43NP-560KC](#) [CR43NP-680KC](#) [CR54NP-181KC](#) [CR54NP-470LC](#) [CR54NP-820KC](#) [CR54NP-8R5MC](#) [70F224AI](#) [MGDQ4-00004-P](#) [MHL1ECTTP18NJ](#) [MHQ1005P10NJ](#) [MHQ1005P1N0S](#) [MHQ1005P2N4S](#) [MHQ1005P3N6S](#) [MHQ1005P5N1S](#) [MHQ1005P8N2J](#) [PE-51506NL](#) [PE-53601NL](#) [PE-53602NL](#) [PE-53630NL](#) [PE-53824SNLT](#) [PE-92100NL](#) [PG0434.801NLT](#) [PG0936.113NLT](#) [9220-20](#) [9310-16](#) [PM06-2N7](#) [PM06-39NJ](#) [A01TK](#) [1206CS-471XJ](#) [HC2LP-R47-R](#) [HC2-R47-R](#) [HC3-2R2-R](#) [HCF1305-3R3-R](#) [1206CS-151XG](#) [RCH664NP-140L](#) [RCH664NP-4R7M](#) [RCH8011NP-221L](#) [RCP1317NP-332L](#) [RCP1317NP-391L](#)