



ISO9001 ISO14001 IATF16949 CHILISIN ELECTRONICS CORP.

RoHS & Halogen Free & REACH Compliance.

SPECIFICATION FOR APPROVAL

Customer :

Customer P/N:

Drawing No :

C3X2000154

Quantity :

0

Pcs.

Date :

2020/07/21

Chilisin P/N :

MHCHL252012F-2R2M-Q8A

SPECIFICATION ACCEPTED BY:

COMPONENT ENGINEER	
ELECTRICAL ENGINEER	
MECHANICAL ENGINEER	
APPROVED	
REJECTED	

奇力新電子股份有限公司

Chilisin Electronics Corp
No. 29, Alley 301, Tehsin Rd.,
Hukou, Hsinchu 303, Taiwan
TEL : +886-3- 599-2646
FAX : +886-3- 599-9176
E-mail : sales@chilisin.com
http : //www.chilisin.com

東莞奇力新電子(東莞廠)有限公司

Chilisin Electronics (Dongguan) Co., Ltd.
No. 78, Puxing Rd., Yuliangwei Administration
Area, Qingxi Town, Dongguan City,
Guangdong, China
TEL : +86-769-8773-0251~3
FAX : +86-769-8773-0232
E-mail : cect@chilisin.com

奇力新電子(越南廠)有限公司

Chilisin Electronics (Vietnam) Limited
No 143 - 145, Road No 10, VSIP Hai
Phong, Lap Le Commune, Thuy Nguyen
Dist, Haiphong City, Vietnam
Tel : 84-316 255 688 Fax : 84-316 255
689
E-mail : sales@chilisin.com

奇力新電子(湖南廠)有限公司

HuNan Chilisin Electronics Technology Co., Ltd
No. 8, Shaziao Liangshuijing Town, Yuanling
County, Huaihua City, Hunan Province 419601,
China
Tel : 86-745-867-5882
E-mail : cect@chilisin.com

Drawn by

張鈺雯 chang.yuwen

Checked by

張鈺雯 chang.yuwen

Approved by

葉信賢 Ben.Yeh

MHCHL252012F Series Specification

1 Scope: This specification applies to Molding power inductors

2 Part Numbering:

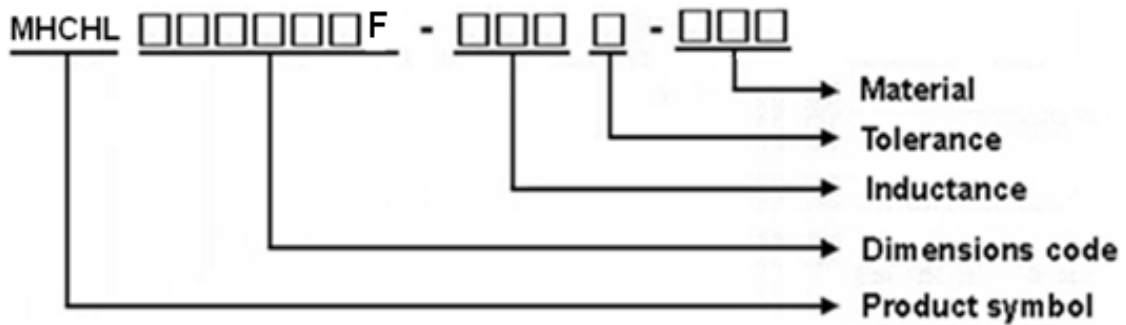

3 Rating:

Operating Temperature: - 4 0 °C ~ 1 2 5 °C(Including self - temperature rise)

Storage Temperature: - 4 0 °C ~ 1 2 5 °C(after PCB)

- 5 °C ~ 3 5 °C, Humidity 4 5 % ~ 8 5 %(before PCB)

4 Marking:

No Marking

5 Standard Testing Condition

	Unless otherwise specified	In case of doubt
Temperature	Ordinary Temperature(15 to 35°C)	20 to 30°C
Humidity	Ordinary Humidity(25 to 85% RH)	50 to 80 %RH

MHCHL252012F Series Specification

6 Configuration and Dimensions:

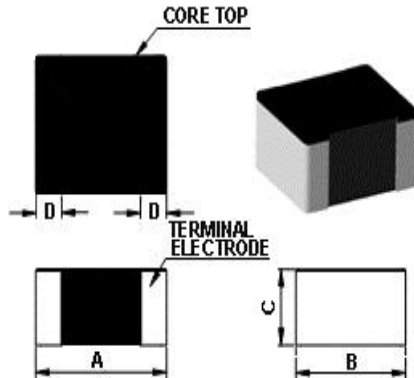

Dimensions in mm

TYPE	MHCHL252012F
A	2.5±0.2
B	2.05±0.2
C	1.2Max.
D	0.6±0.3

7 Electrical Characteristics:

Part No.	Inductance (uH)	Tolerance (±%)	Test Freq.	I _{rms} (A) Max.	I _{sat} (A) Max.	RDC(mΩ) Max.
MHCHL252012F-2R2M-Q8A	2.2	20	2MHz,0.2V	2.4	3.0	103

NOTE:

1. Operating temperature range - 40°C ~ 125°C (Including self - temperature rise)
2. I_{sat} for Inductance drop 30% from its value without current.
3. I_{rms} for a 40°C temperature rise from 25°C ambient.
4. Rated current: I_{sat} or I_{rms}, whichever is smaller
5. All test data is referenced to 25°C ambient
6. Absolute maximum voltage 20VDC

MHCHL252012F Series Specification

8 MHCHL252012F Series

8.1 Construction:

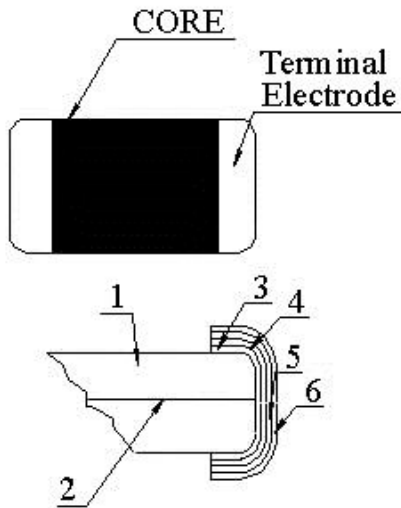

8.2 Material List:

NO	Part	Description
1	Core	Metal Powder
2	Wire	Copper wire
3	Sputter/Plating	Cu
4	Silver Electrode	Ag
5	Plating	Ni
6	Plating	Sn

MHCHL252012F Series Specification

9 Reliability of Molding Power Inductor

1-1. Mechanical Performance

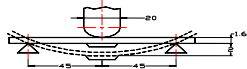
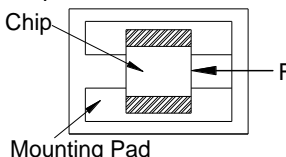
No	Item	Specification	Test Method
1-1-1	Flexure Strength	The forces applied on the right conditions must not damage the terminal electrode and the metal body	Test device shall be soldered on the substrate Substrate Dimension: 100x40x1.6mm Deflection: 2.0mm Keeping Time: 30sec 
1-1-2	Vibration	Appearance: No damage (for microscope of CASTOR MZ-45 20X) Inductance change shall be within $\pm 20\%$	Test device shall be soldered on the substrate Oscillation Frequency: 10 to 55 to 10Hz for 1min Amplitude: 1.5mm Time: 2hrs for each axis (X, Y & Z), total 6hrs
1-1-3	Resistance to Soldering Heat	Appearance: No damage More than 75% of the terminal electrode should be covered with solder. Inductance: within $\pm 20\%$ of initial value	Pre-heating: 150°C, 1min Solder Composition: Sn/Ag3.0/Cu0.5(Pb-Free) Solder Temperature: 260 \pm 5°C Immersion Time: 10 \pm 1sec
1-1-4	Solder ability	The electrodes shall be at least 95% covered with new solder coating	Pre-heating: 150°C, 1min Solder Composition: Sn/Ag3.0/Cu0.5(Pb-Free) Solder Temperature: 245 \pm 5°C Immersion Time: 4 \pm 1sec
1-1-5	Terminal Strength Test	No split termination  Chip Mounting Pad	Test device shall be soldered on the substrate, then apply a force in the direction of the arrow. Force : 5N Keeping Time: 10 \pm 1sec

1-2. Environmental Performance

No	Item	Specification	Test Method		
1-2-1	Temperature Cycle	Appearance: No damage Inductance: within $\pm 20\%$ of initial value	One cycle:		
			Step	Temperature (°C)	Time (min)
			1	-40 \pm 3	30
			2	25 \pm 2	3
			3	125 \pm 3	30
4	25 \pm 2	3			
			Total: 100cycles Measured after exposure in the room condition for 24hrs		
1-2-2	Humidity Resistance		Temperature: 60 \pm 2°C Relative Humidity: 90 ~ 95% / Time: 500hrs Measured after exposure in the room condition for 24hrs		
1-2-3	High Temperature Resistance		Temperature: 85 \pm 3°C Relative Humidity: 0% / Time: 500hrs Measured after exposure in the room condition for 24hrs		
1-2-4	Low Temperature Resistance		Temperature: -40 \pm 3°C Relative Humidity: 0% / Time: 500hrs Measured after exposure in the room condition for 24hrs		

MHCHL252012F Series Specification

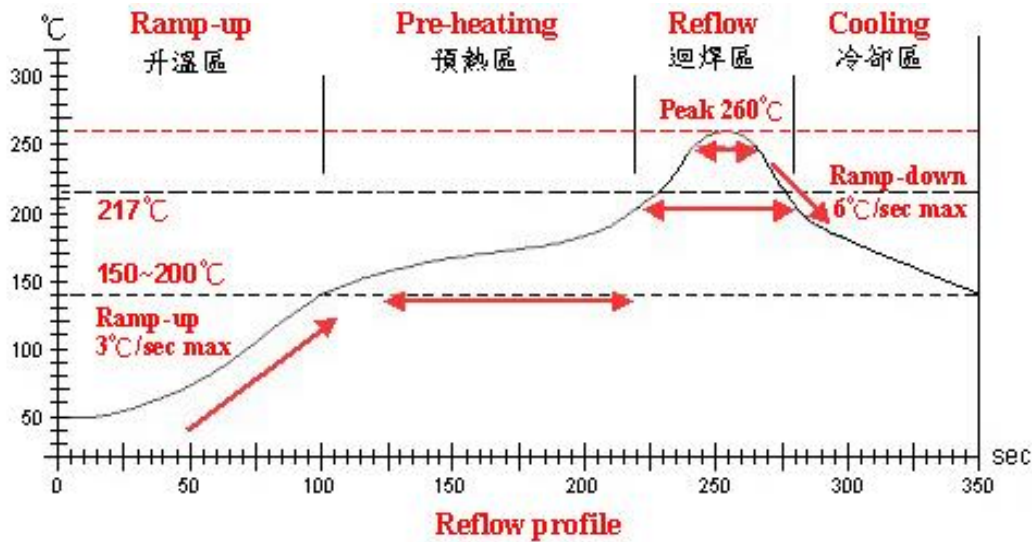

Lead-Free(LF) 標準溫度分析範圍

Refer to J-STD-020C

管制項目 Item.	升温區 Ramp-up	預熱區 Pre-heating	迴焊區 Reflow	Peak Temp	冷卻區 Cooling
溫度範圍 Temp. scope	R.T. ~ 150°C	150°C ~ 200°C	217°C	260±5°C	Peak Temp. ~ 150°C
標準時間 Time spec.	—	60 ~ 180 sec	60 ~ 150 sec	20 ~ 40 sec	—
實際時間 Time result	—	75 ~ 100 sec	90 ~ 120 sec	20 ~ 35 sec	—

NOTE :

1. Re-flow possible times : within 2 times
2. Nitrogen adopted is recommended while in re-flow

MHCHL252012F Series Specification

10 PACKAGING

10.1 Packaging -Cover tape

The force for tearing off cover tape is 10 to 100 grams in the arrow direction.

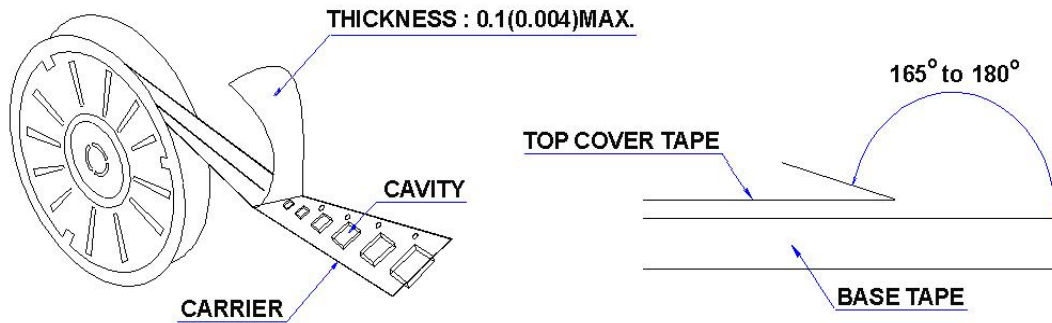

10.2 Packaging Quantity

TYPE	PCS/REEL
MHCHL252012F	3000

10.3 Reel Dimensions

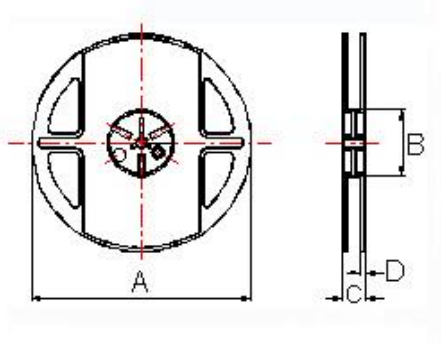

Dimensions in mm

TYPE	A	B	C	D
MHCHL252012F	178	60	12	1.5

MHCHL252012F Series Specification

10 Packaging:

10.4 Tape Dimensions in mm

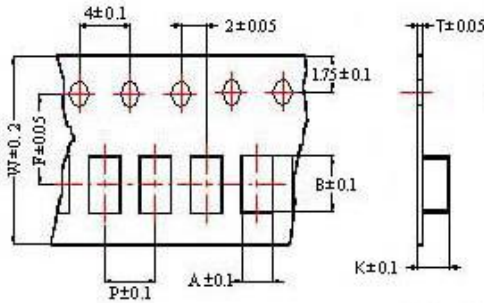

Tape Material

Carrier tape : Polycarbonate

Cover tape : Polyethylene

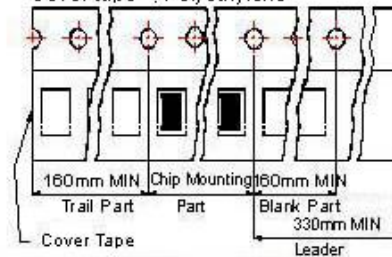

TYPE	A	B	T	W	P	F	K
MHCHL252012F	2.25	2.80	0.22	8	4	3.5	1.35

11 Recommended Land Pattern:

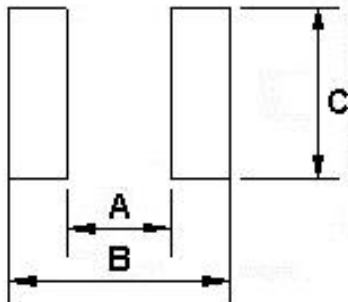

Dimensions in mm

TYPE	A	B	C
MHCHL252012F	1.2	2.8	2.3

12 Note:

1. Please make sure that your product has been evaluated and confirmed against your specifications when our product is mounted to your product.
2. Do not knock nor drop.
3. All the items and parameters in this product specification have been prescribed on the premise that our product is used for the purpose, under the condition, and in the environment agreed upon between you and us. You are requested not to use our product deviating from such agreement.
4. Please keep the distance between transformer/coil and other components (refer to the standard IEC 950)
5. After manufacturing process, there might be slight irregular shape on the edge of the products, and it's a normal phenomenon that can be neglected.
6. The moisture sensitivity level (MSL) of products is classified as level 1.



MHCHL252012F Series Specification

13 Graph: MHCHL252012F-2R2M-Q8A

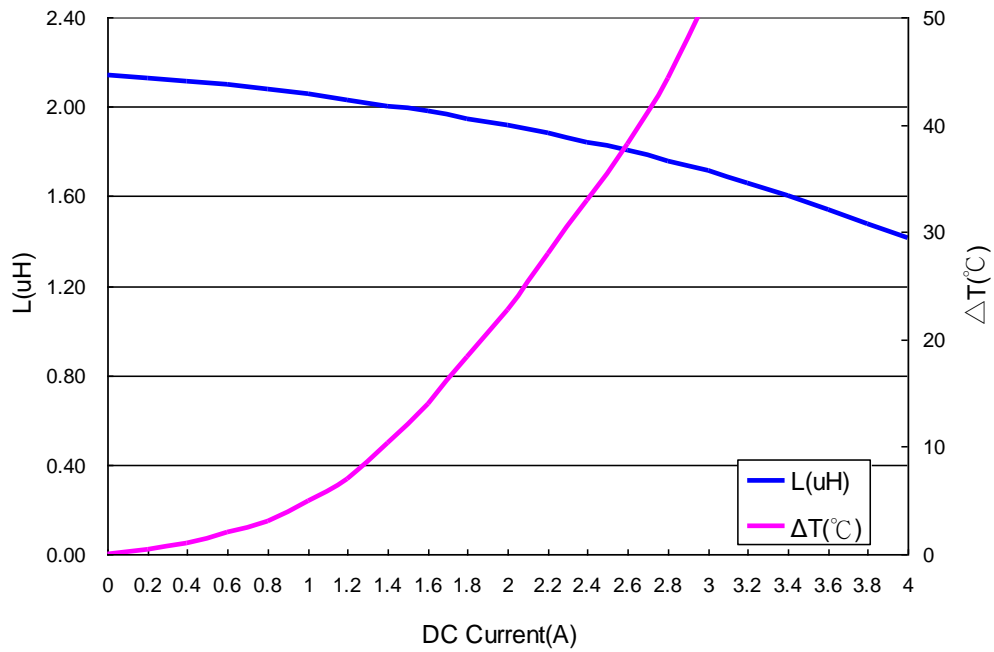

X-ON Electronics

Largest Supplier of Electrical and Electronic Components

Click to view similar products for [Fixed Inductors](#) category:

Click to view products by [Chilisin](#) manufacturer:

Other Similar products are found below :

[CR32NP-100KC](#) [CR54NP-470LC](#) [70F224AI](#) [MGDQ4-00004-P](#) [MHQ1005P10NJ](#) [MHQ1005P1N0S](#) [MHQ1005P2N4S](#) [MHQ1005P3N6S](#)
[MHQ1005P5N1S](#) [MHQ1005P8N2J](#) [PE-53601NL](#) [PE-53602NL](#) [PG0936.113NLT](#) [9220-20](#) [9310-16](#) [PM06-2N7](#) [PM06-39NJ](#) [A01TK](#)
[1206CS-471XJ](#) [HC2-R47-R](#) [HC8-1R2-R](#) [HCF1305-3R3-R](#) [1206CS-151XG](#) [RCH664NP-140L](#) [RCH664NP-4R7M](#) [RCP1317NP-391L](#)
[RCR110DNP-331L](#) [DH2280-4R7M](#) [DS1608C-106](#) [B10TJ](#) [B82498B3101J000](#) [ELJ-RE27NJF2](#) [1812CS-153XJ](#) [1812CS-183XJ](#) [1812CS-](#)
[223XJ](#) [1812LS-104XJ](#) [1812LS-105XJ](#) [1812LS-124XJ](#) [1812LS-154XJ](#) [1812LS-223XJ](#) [1812LS-224XJ](#) [1812LS-563XJ](#) [1812LS-683XJ](#)
[1812LS-824XJ](#) [NIN-FB101JTR110F](#) [NIN-FB471JTR62F](#) [NIN-FC1R5JTR220F](#) [NIN-HCR15JTRF](#) [NIN-HCR33JTRF](#) [NIN-HDR22JTRF](#)