

NH40 系列隔离开关

1 适用范围

NH40系列隔离开关，适用于交流50Hz、交流额定电压690V及以下，额定电流至3150A。

在工业企业配电设备中，可供不频繁手动接通和分断电路及隔离电源用，其中125A~630A可作为频繁接通和分断，本系列开关不得作为直接启动单台电动机之用。

符合标准：GB/T14048.3、IEC60947-3。



NH40-16~63/3II



NH40-16~100/4



NH40-100/4 III



NH40-100/4K



NH40-125/3BC

2 型号及含义

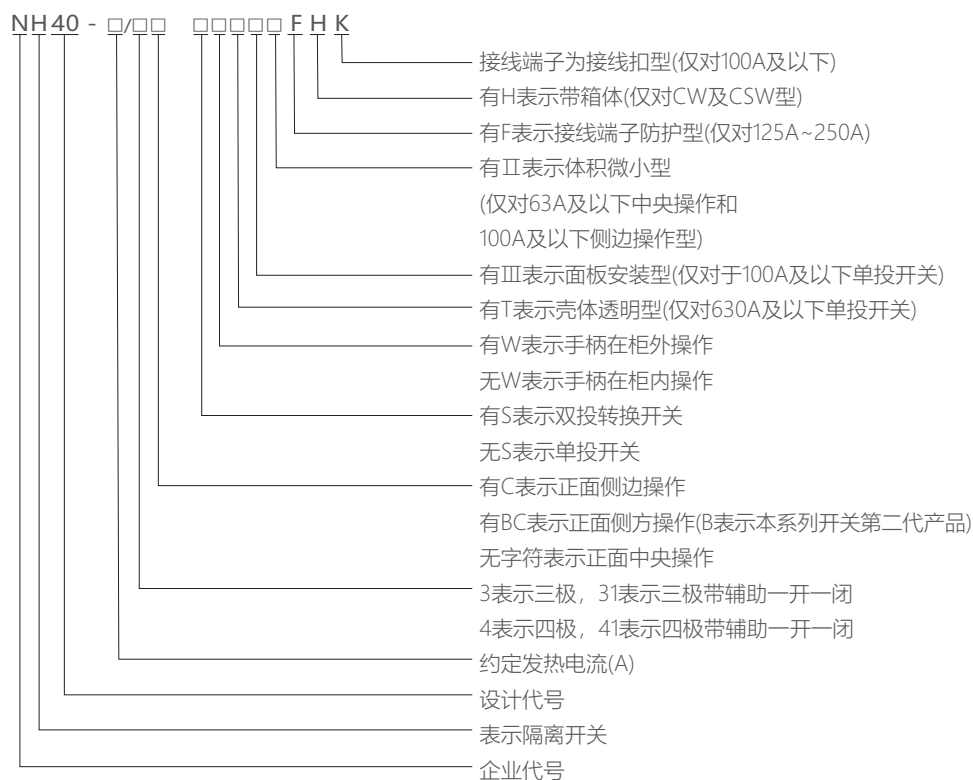

3 正常工作条件和安装条件

- 3.1 周围空气温度不高于+40℃，不低于-5℃。
- 3.2 安装地点的海拔不超过2000m。
- 3.3 湿度：最高温度为+40℃时，空气的相对湿度不超过50%，在较低的温度下可以允许有较高的相对湿度，例如20℃时达90%。对由于温度变化偶尔产生的凝露应采取特殊的措施。
- 3.4 周围环境的污染等级为3级。
- 3.5 开关应安装在无显著摇动、冲击振动和没有雨雪侵袭的地方，同时安装地点应无爆炸危险介质，且介质中无足以腐蚀金属和破坏绝缘的气体 and 尘埃。

4 主要参数及技术性能



NH40-160/41

NH40-16~100 III型						
约定发热电流 Ith (A)	16	20	32	63	80	100
额定绝缘电压 Ui (V)	800					
额定冲击耐受电压 Uimp (KV)	8					
额定工作电流 Ie (A)	16	20	32	63	80	100
额定工作电压 Ue (V)	415					
使用类别	AC-23A					
额定短时耐受电流 Icw (KA)	1.26	1.26	1.26	1.26	2	2
额定接通能力 (A)	320	320	320	630	1000	1000
额定分断能力 Icn (A)	256	256	256	504	800	800
机械寿命	8500					
电寿命	1500					
操作力(N)	30~60					



NH40-250/41

NH40-16~250及16~100 II型													
约定发热电流 Ith (A)		16	32	40	63	80	100	125	160	200	250		
额定绝缘电压 Ui (V)		1000											
额定冲击耐受电压 Uimp (KV)		8						12					
额定工作 电流 Ie(A)	415V	AC21B	16	32	40	63	80	100	125	160	200	250	
		AC23A	-	-	-	-	-	-	125	160	200	250	
	690V	AC21B	16	32	40	63	63	63	125	160	200	250	
		AC23A	-	-	-	-	-	-	50	63	70	80	
额定短时耐受电流 Icw(KA)		415V	2	2	2	2	2	2	7	7	9	9	
额定接通能力(A)		415V	150	150	150	150	150	150	1250	1600	2000	2500	
额定分断能力Icn(A)			150	150	150	150	150	150	1000	1280	1600	2000	
机械寿命			12000						12000				
电寿命			300						1000				
操作力(N)			30~50						40~60				



NH40-315/4

NH40-315~3150													
约定发热电流 Ith (A)		315	400	630	1000	1250	1600	2000	2500	3150			
额定绝缘电压 Ui (V)		1000											
额定冲击耐受电压(KV)		12											
额定工作 电流 Ie(A)	415V	AC22B	315	400	630	1000	1250	1600	2000	2500	3150		
		AC23A	315	400	630	-	-	-	-	-	-		
	690V	AC22B	250	250	315	800	800	800	1000	1000	1250		
		AC23A	125	160	200	-	-	-	-	-	-		
额定短时耐受电流 Icw(KA)		415V	20	20	20	30	30	30	50	50	50		
额定接通能力Icm(A)		415V	3150	4000	6300	3000	3750	4800	6000	7500	9450		
额定分断能力Icn(A)			2520	3200	5040	3000	3750	4800	6000	7500	9450		
机械寿命			12000			4000			2500				
电寿命			1000			100							
操作力(N)			65~100			200~300							

NH40-16~125/BC (第二代产品)										
约定发热电流 Ith(A)		16	25	32	40	63	80	100	125	
额定绝缘电压 Ui(V)		1000								
额定冲击耐受电压 Uimp(kV)		8								
额定工 作电 流 Ie(A)	415V	AC22B	16	25	32	40	63	80	100	125
		AC23B	16	25	32	40	63	80	100	125
	690V	AC22B	16	25	32	40	63	80	100	125
		AC23B	16	25	32	40	63	80	80	80
额定短时耐受电流 Icw(kA)		5								
额定接通能力 (A)		10Ie								
额定分断能力 Icn(A)		8Ie								
机械寿命(次)		7000								
电寿命(次)		300								
操作力(N)		40~60								

NH40-160~630/BC (第二代产品)						
约定发热电流 $I_{th}(A)$	160	200	250	315	400	630
额定绝缘电压 $U_i(V)$	1000					
额定冲击耐受电压 $U_{imp}(kV)$	8					
额定工作电流 $I_e(A)$	415V	AC23B	160	200	250	315
	690V	AC23B	160	200	250	315
额定短时耐受电流 $I_{cw}(kA)$	10	10	10	15	15	25
额定接通能力 (A)	10I _e					
额定分断能力 $I_{cn}(A)$	8I _e					
机械寿命(次)	4000					
电寿命(次)	300					
操作力(N)	60~100					

5 安装方式

安装方式如图所示，柜外操作需加装长轴，要求装在面(门)板上的手柄(轴)和长轴同轴(对准)。否则，柜门不易开闭及操作费力，并导致操作机构损坏。按照产品至门板的安装距离、并加上轴伸入手柄的长(约30毫米)确定轴的长度。



NH40-400/4



NH40-630/4



NH40-1000/3

图 1



图 2



6 外形及安装尺寸

6.1 NH40-16A~100A/3、NH40-16A~100A/3W型外形及安装尺寸

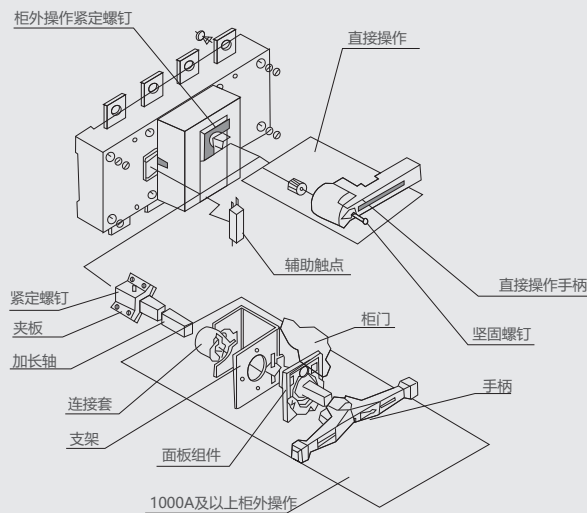
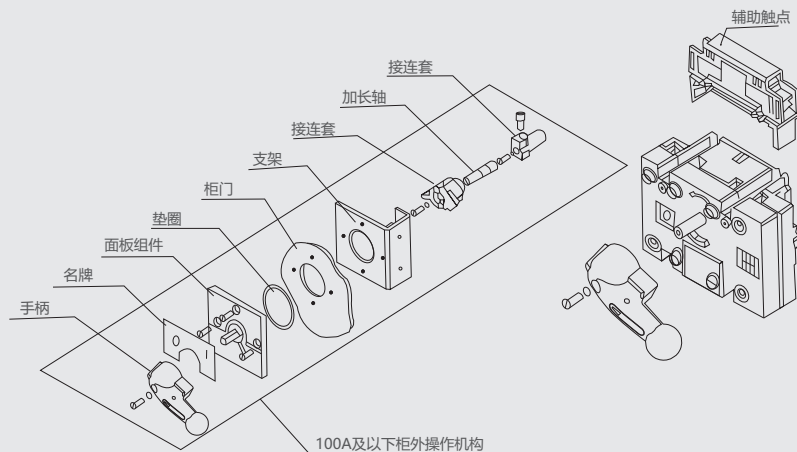

NH40-16~100/3



NH40-16~100/4

图 3

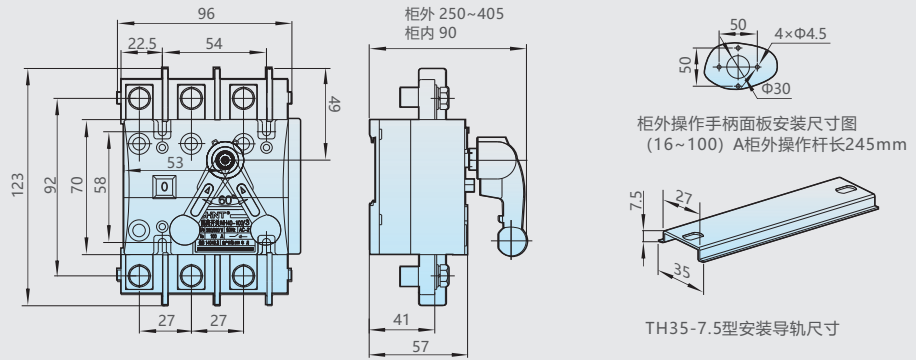

6.2 NH40-16A~100A/4、NH40-16A~100A/4W型外形及安装尺寸

图 4

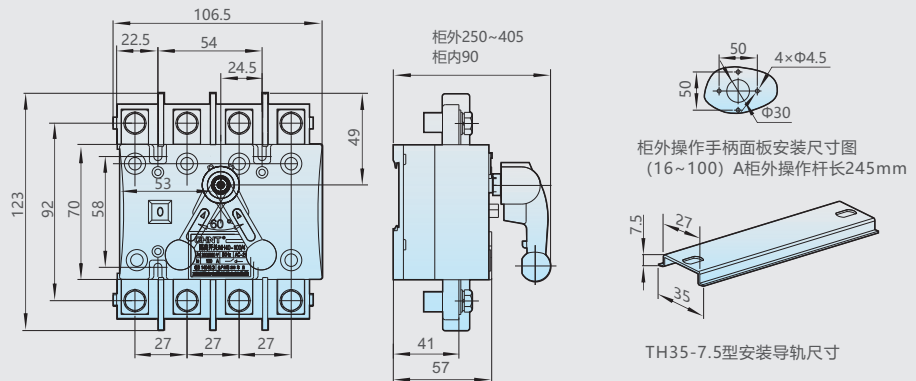



NH40-100/4T

6.3 NH40-16A~100A/3K、4K; NH40-16A~100A/3KW、4KW型外形及安装尺寸

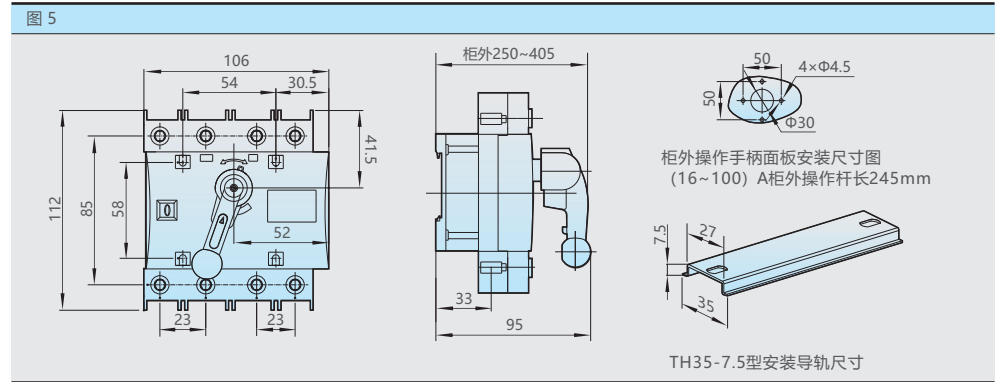

NH40-16~63/4II

6.4 NH40-16A~63A/3II、4II; NH40-16A~63A/3IIW、4IIW型外形及安装尺寸

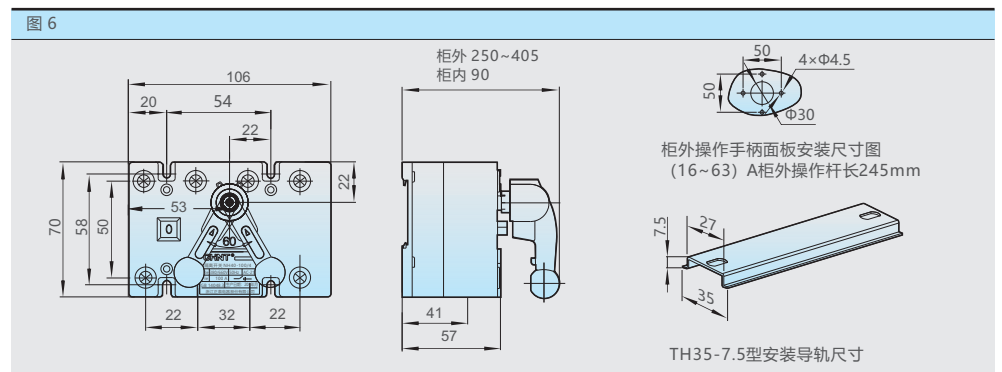

NH40-100/3 III

6.5 NH40-16A~63A/3SII、4SII; NH40-16A~63A/3SIIW、4SIIW型外形及安装尺寸

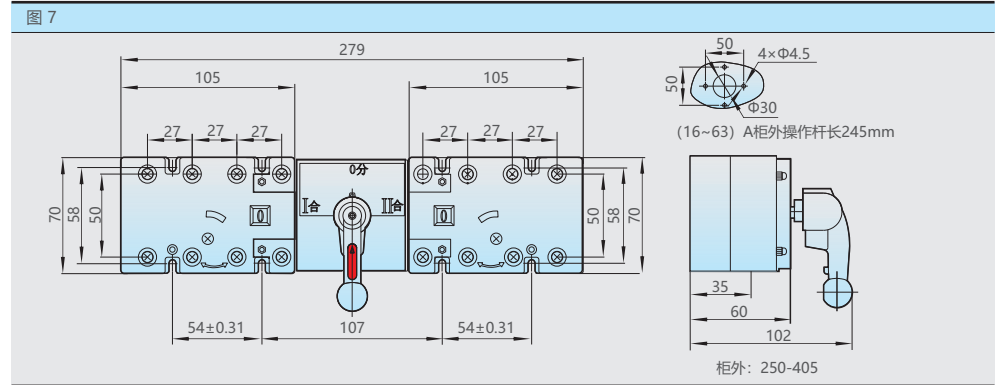

NH40-160/4TF

6.6 32A~100AⅢ型隔离开关外形及安装尺寸



NH40-100/3 III

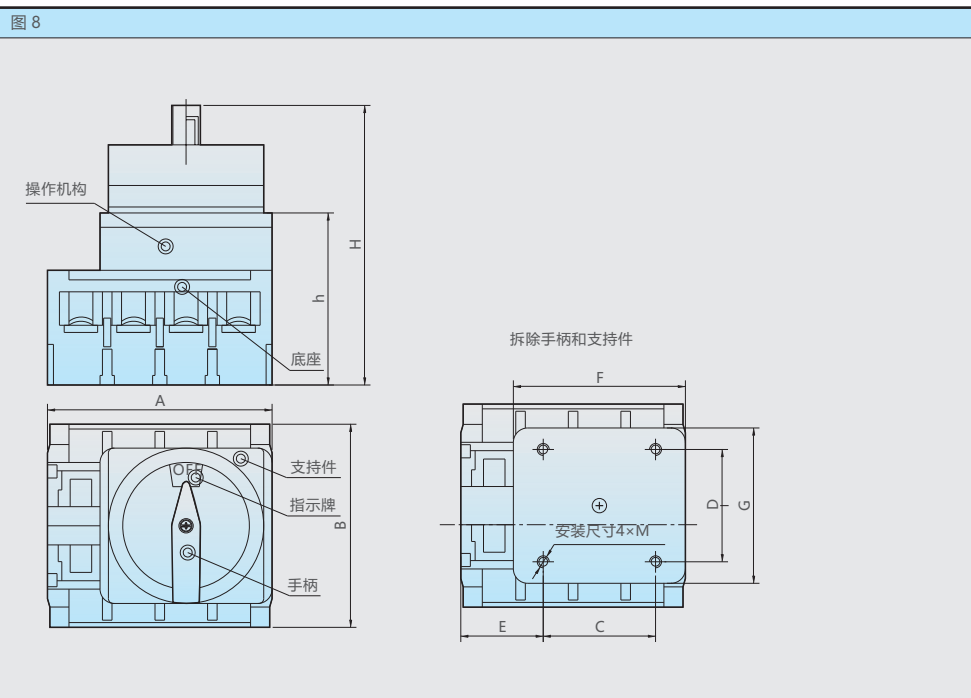

型号与规格	A	B	C	D	E	F	G	h	H	M
NH40-32/3Ⅲ	65	65	48	48	-	65	65	55	98	4
NH40-32/4Ⅲ	68	65	48	48	8	65	65	55	98	4
NH40-63/3Ⅲ	65	67	48	48	-	65	65	62	105	4
NH40-63/4Ⅲ	75	67	48	48	18	65	65	62	105	4
NH40-100/3Ⅲ	72	85	48	48	12	71	65	74	117	4
NH40-100/4Ⅲ	94	85	48	48	34	71	65	74	117	4

NH40-160/4TF



NH40-630/4TF



NH40-125/4F
NH40-160/4F
NH40-200/4F
NH40-250/4F

6.7 125A~630A隔离开关外形及安装尺寸

图 9

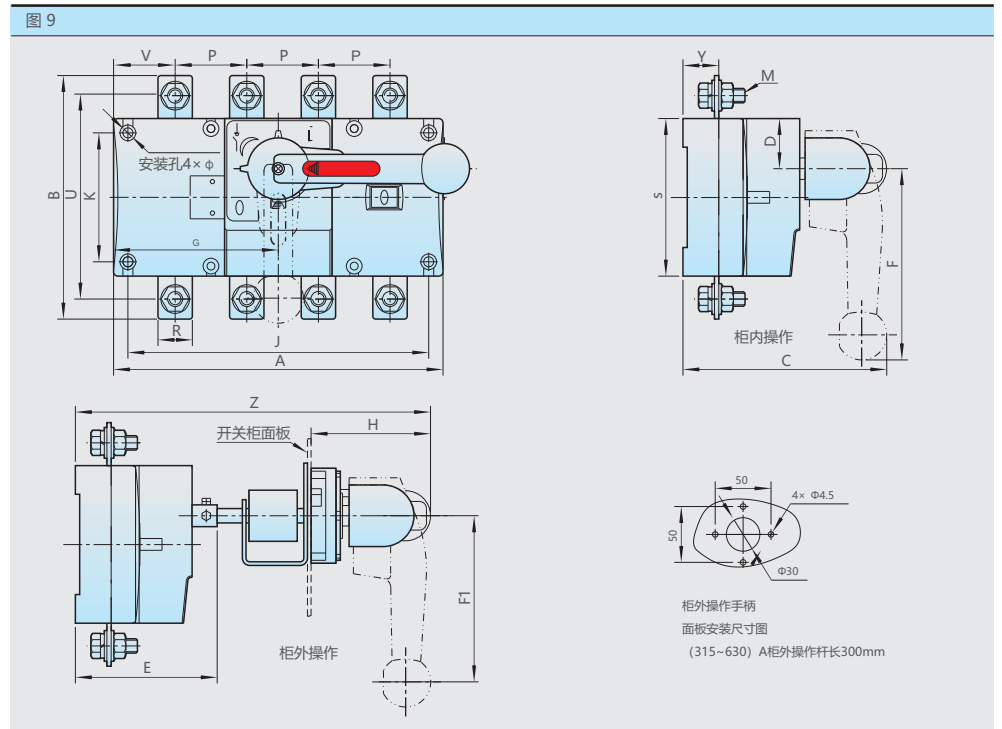

NH40柜内操作及NH40柜外隔离开关安装尺寸

规格	NH40-XX NH40-XX/W外形及安装尺寸(mm)																			
电流	A	B	C	D	E	F	F1	Φ	J	H	K	G	P	R	S	U	M	V	Y	Z
125A/3	140	135	130	27	93	105	135	5.5	120	85	65	55	36	18	85	115	8	37	24	355~460
160A/3	140	135	130	27	93	105	135	5.5	120	85	65	55	36	20	85	115	8	38	24	355~460
125A/4	170	135	130	27	93	105	135	5.5	150	85	65	85	36	18	85	115	8	31	24	355~460
160A/4	170	135	130	27	93	105	135	5.5	150	85	65	85	36	20	85	115	8	32	24	355~460
200A/3	180	170	145	35	103	135	135	6.5	160	85	90	60	50	25	110	142	10	43	25	365~470
250A/3	180	170	145	35	103	135	135	6.5	160	85	90	60	50	25	110	142	10	43	25	365~470
200A/4	230	170	145	35	103	135	135	6.5	210	85	90	110	50	25	110	142	10	43	25	365~470
250A/4	230	170	145	35	103	135	135	6.5	210	85	90	110	50	25	110	142	10	43	25	365~470
315A/3	230	240	195	50	135	160	160	7	210	105	140	84	65	32	160	205	12	52	37	440~555
400A/3	230	240	195	50	135	160	160	7	210	105	140	84	65	35	160	205	12	53	37	440~555
630A/3	230	260	195	50	135	160	160	7	210	105	140	84	65	40	160	220	12	52	37	440~555
315A/4	290	240	195	50	135	160	160	7	270	105	140	144	65	32	160	205	12	47	37	440~555
400A/4	290	240	195	50	135	160	160	7	270	105	140	144	65	35	160	205	12	48	37	440~555
630A/4	290	260	195	50	135	160	160	7	270	105	140	144	65	40	160	220	12	47	37	440~555

6.8 1000A~1600A隔离开关外形及安装尺寸

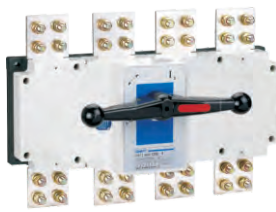

NH40-1250/41



NH40-1600/31

图 10

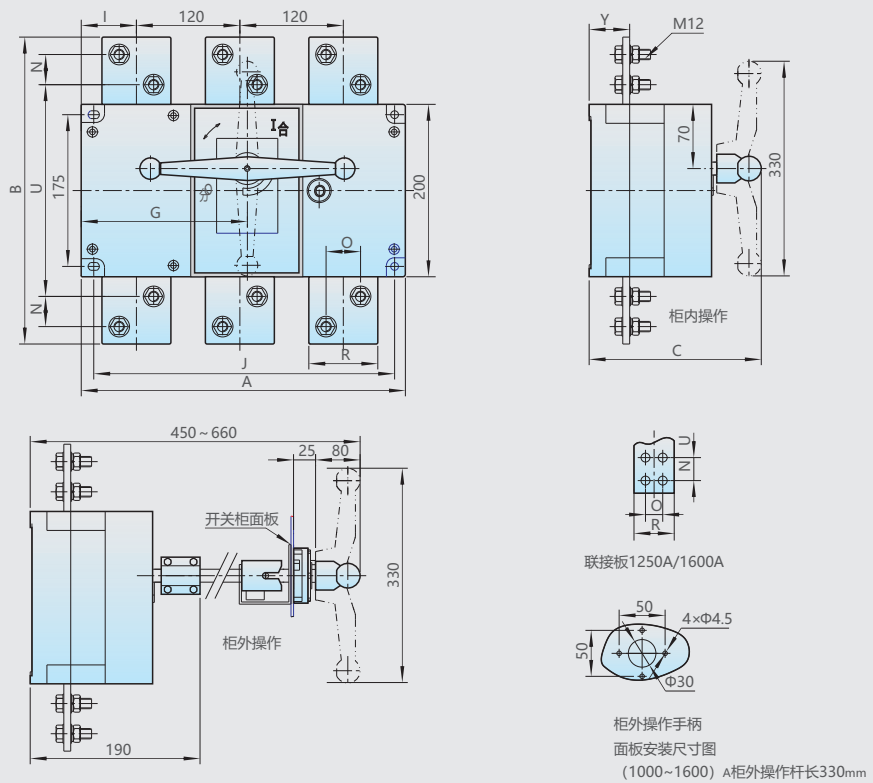

NH40柜内操作及NH40柜外隔离开关安装尺寸

规格	NH40-XX NH40-XX/W 外形及安装尺寸(mm)										
电流	A	B	C	G	I	J	N	R	O	U	Y
1000A/3	378	316	240	192.5	66	353	22	60	32	236	48
1250A/3	378	356	240	192.5	66	353	35	70	34	246	48
1600A/3	378	356	240	192.5	66	353	35	80	40	246	48
1000A/4	492	316	240	246	61	468	22	60	32	236	48
1250A/4	492	356	240	246	61	468	35	70	34	246	48
1600A/4	492	356	240	246	61	468	35	80	40	246	48

6.9 2000A~3150A隔离开关外形及安装尺寸

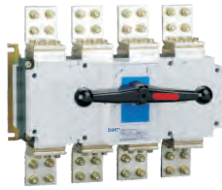

NH40-2000/4



NH40-3150/3

图 11

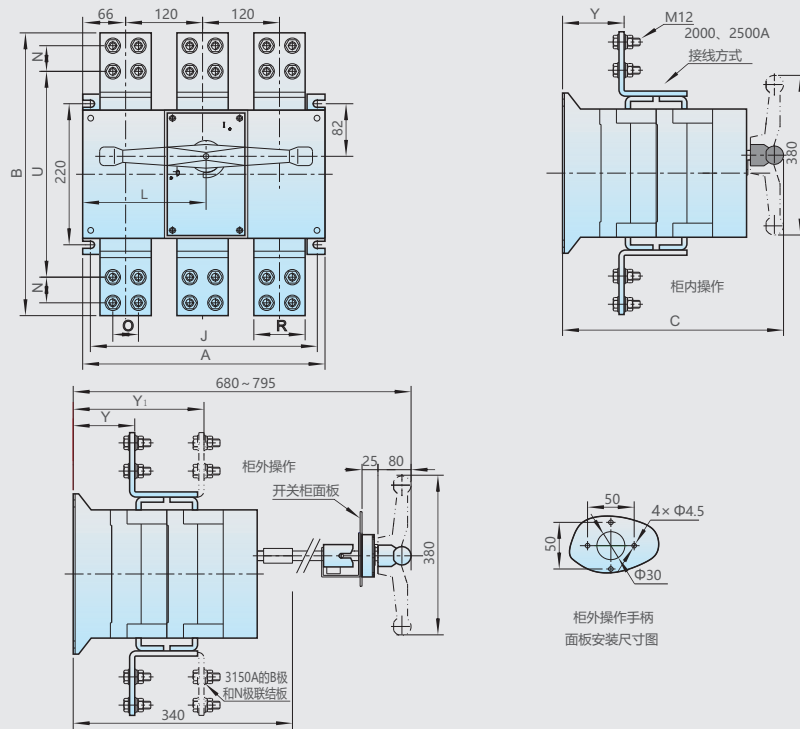

NH40柜内操作及NH40柜外隔离开关安装尺寸



NH40-16~100/3CSII

规格	NH40-XX NH40-XX/W 外形及安装尺寸(mm)										
电流	A	B	C	L	J	N	O	U	R	Y	Y1
2000A/3	378	440	374	192.5	353	40	40	310	80	105	-
2500A/3	378	440	374	192.5	353	40	40	310	80	105	-
3150A/3	378	510	374	192.5	353	50	50	360	120	105	210
2000A/4	492	440	374	246	473	40	40	310	80	105	-
2500A/4	492	440	374	246	473	40	40	310	80	105	-
3150A/4	492	510	374	246	473	50	50	360	120	105	210

6.10 NH40-16~100/C II型及 NH40-16~100/CSII型外形与安装尺寸

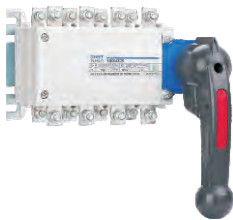

NH40-16~100/4CS

图 12

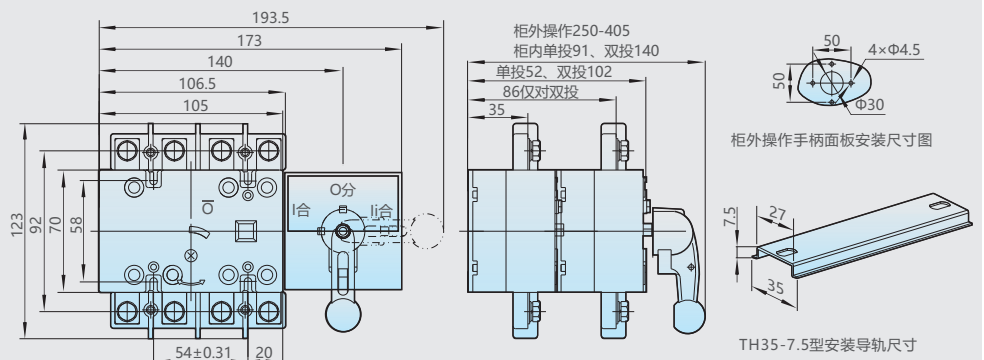

6.11 NH40-16~1600/C 及 NH40-16~1600/CS 安装尺寸



NH40-250/4CS



NH40-630/4CS



NH40-1000/3CS



NH40-1600/3CS

图 13

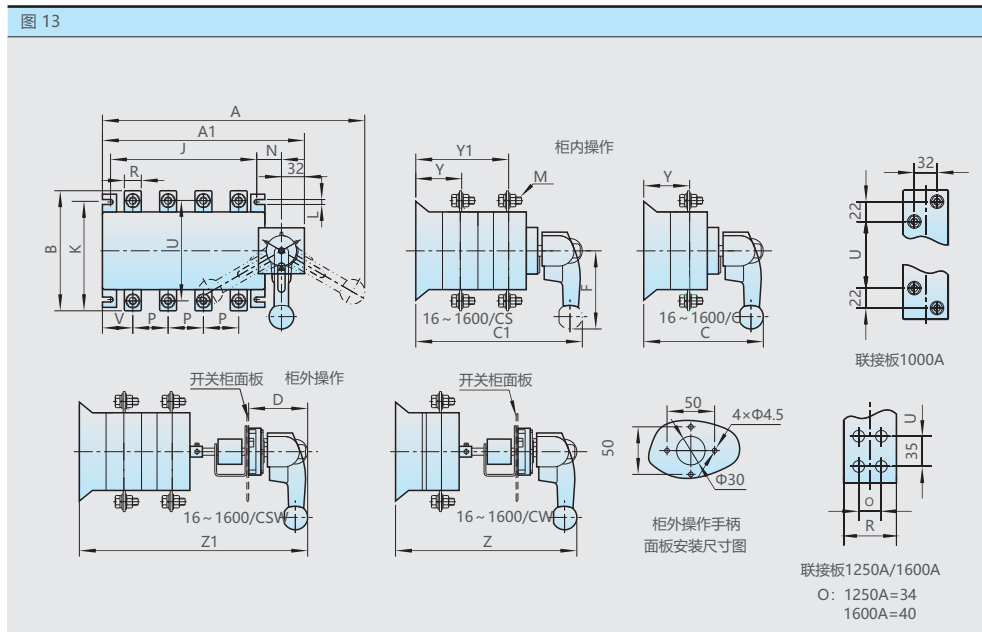

NH40侧方操作及NH40双投转换隔离开关安装尺寸

规格	NH40-XX/C NH40-XX/CS外形及安装尺寸(mm)																			
电流	A	A1	B	C	C1	D	F	J	K	L	N	P	R	U	V	M	Y	Y1	Z	Z1
16~100A/3	290	170	107	135	185	85	135	116	84	7	25	30	14	90	20	6	39	90	360~465	440~545
125A/3	295	192	135	155	235	85	135	120	95	7	29.5	36	18	115	31	8	58	122	410~515	480~595
160A/3	295	192	135	155	235	85	135	120	95	7	29.5	36	20	115	30	8	58	122	410~515	480~595
16~100A/4	290	170	107	135	185	85	135	116	84	7	25	30	14	90	20	6	39	90	360~465	440~545
125A/4	325	222	135	155	235	85	135	150	95	7	29.5	36	18	115	31	8	58	122	410~515	480~595
160A/4	325	222	135	155	235	85	135	150	95	7	29.5	36	20	115	30	8	58	122	410~515	480~595
200A/3	335	232	170	176	260	85	135	160	115	7	29.5	50	25	142	37	10	67	148	430~535	510~615
250A/3	335	232	170	176	260	85	135	160	115	7	29.5	50	25	142	37	10	67	148	430~535	510~615
200A/4	385	282	170	176	260	85	135	210	115	7	29.5	50	25	142	37	10	67	148	430~535	510~615
250A/4	385	282	170	176	260	85	135	210	115	7	29.5	50	25	142	37	10	67	148	430~535	510~615
315A/3	430	298	240	233	335	105	160	210	180	9	43	65	32	205	48	12	84	196	515~630	620~735
400A/3	430	298	240	233	335	105	160	210	180	9	43	65	35	205	48	12	84	196	515~630	620~735
630A/3	430	298	260	233	335	105	160	210	180	9	43	65	40	220	48	12	84	196	515~630	620~735
315A/4	490	358	240	233	335	105	160	270	180	9	43	65	32	205	48	12	84	196	515~630	620~735
400A/4	490	358	240	233	335	105	160	270	180	9	43	65	35	205	48	12	84	196	515~630	620~735
630A/4	490	358	260	233	335	105	160	270	180	9	43	65	40	220	48	12	84	196	515~630	620~735
1000A/3	580	445	316	280	424	105	165	353	220	11	47	120	60	236	66	12	108	253	605~720	750~865
1250A/3	580	445	356	280	424	105	165	353	220	11	47	120	70	246	66	12	108	253	605~720	750~865
1600A/3	580	445	356	280	424	105	165	353	220	11	47	120	80	246	66	12	108	253	605~720	750~865
1000A/4	700	565	316	280	424	105	165	473	220	11	47	120	60	236	66	12	108	253	605~720	750~865
1250A/4	700	565	356	280	424	105	165	473	220	11	47	120	70	246	66	12	108	253	605~720	750~865
1600A/4	700	565	356	280	424	105	165	473	220	11	47	120	80	246	66	12	108	253	605~720	750~865

6.12 NH40-2000~3150/C 及 NH40-2000~3150/CS安装尺寸

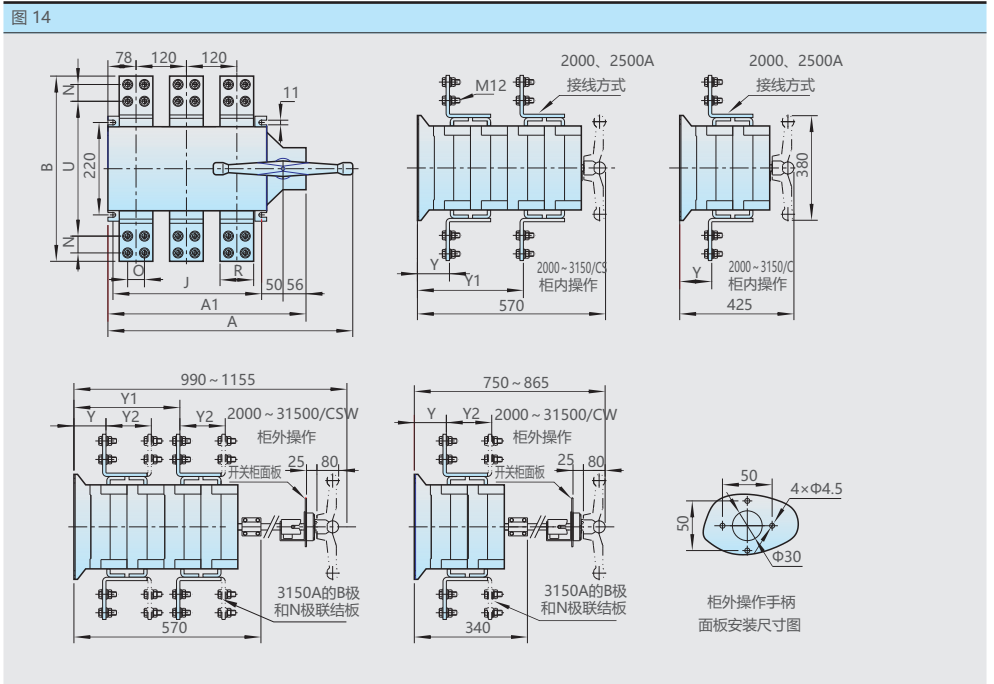

NH40侧方操作及NH40双投转换隔离开关安装尺寸

规格	NH40-XX/C NH40-XX/CS外形及安装尺寸(mm)										
电流	A	A1	B	R	J	U	O	N	Y	Y1	Y2
2000A/3	580	472	440	80	353	310	40	40	105	335	-
2500A/3	580	472	440	80	353	310	40	40	105	335	-
3150A/3	580	472	510	120	353	360	50	50	105	335	105
2000A/4	700	592	440	80	473	310	40	40	105	335	-
2500A/4	700	592	440	80	473	310	40	40	105	335	-
3150A/4	700	592	510	120	473	360	50	50	105	335	105



6.13 NH40-16~100/3S 及 NH40-16~100/4S外形与安装尺寸

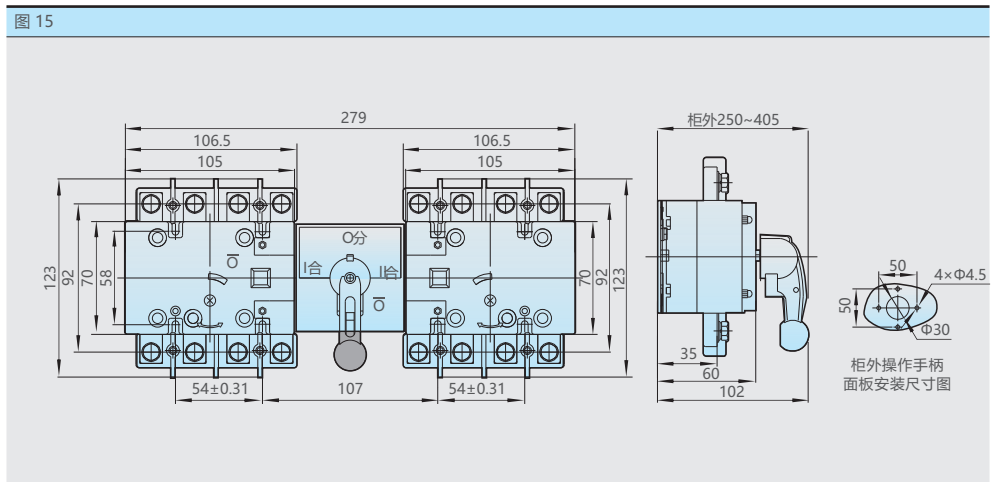

6.14 NH40-125~1600/3S 及 NH40-125~1600/4S外形与安装尺寸



NH40-125/4S



NH40-400/4S



NH40-1000/4S



NH40-1600/4S

图 16

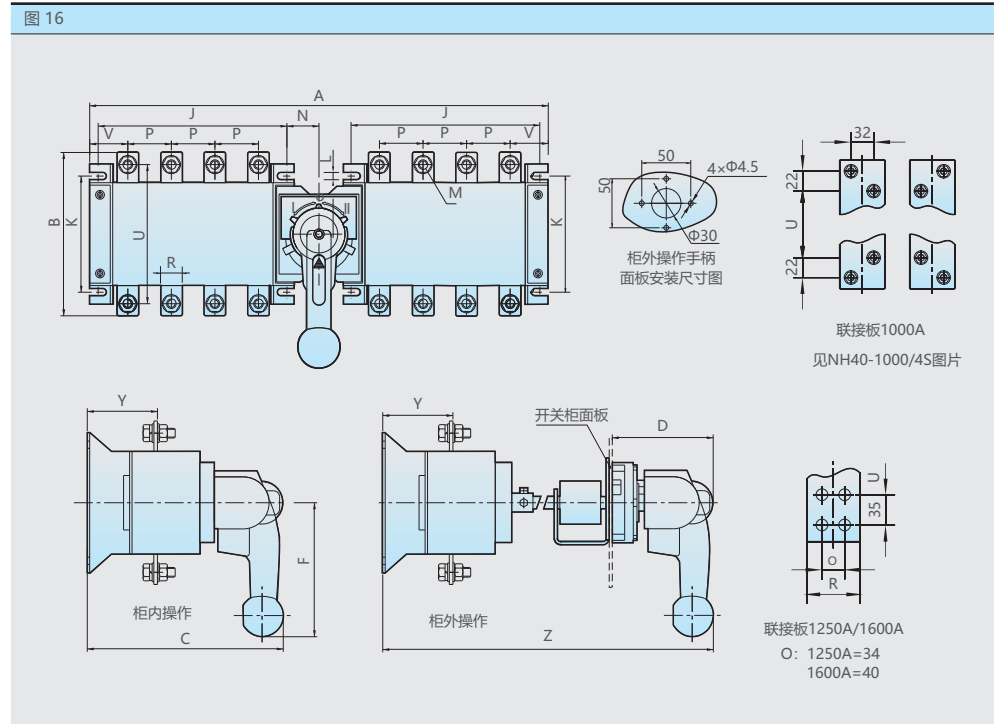

NH40-125~1600/3S 及 NH40-125~1600/4S外形与安装尺寸

规格	A	B	C	D	F	J	K	L	N	P	R	U	V	M	Y	Z
125A/3	308	135	155	85	135	120	95	7	29.5	36	18	115	31	8	58	410~515
160A/3	308	135	155	85	135	120	95	7	29.5	36	20	115	30	8	58	410~515
125A/4	380	135	155	85	135	150	95	7	29.5	36	18	115	31	8	58	410~515
160A/4	380	135	155	85	135	150	95	7	29.5	36	20	115	30	8	58	410~515
200A/3	402	170	176	85	135	160	115	7	29.5	50	25	142	37	10	67	430~535
250A/3	402	170	176	85	135	160	115	7	29.5	50	25	142	37	10	67	430~535
200A/4	501	170	176	85	135	210	115	7	29.5	50	25	142	37	10	67	430~535
250A/4	501	170	176	85	135	210	115	7	29.5	50	25	142	37	10	67	430~535
315A/3	535	240	233	105	160	210	180	9	43	65	32	205	48	12	84	515~630
400A/3	535	240	233	105	160	210	180	9	43	65	35	205	48	12	84	515~630
630A/3	535	260	233	105	160	210	180	9	43	65	40	220	48	12	84	515~630
315A/4	655	240	233	105	160	270	180	9	43	65	32	205	48	12	84	515~630
400A/4	655	240	233	105	160	270	180	9	43	65	35	205	48	12	84	515~630
630A/4	655	260	233	105	160	270	180	9	43	65	40	220	48	12	84	515~630
1000A/3	825	316	280	105	322	353	220	11	50	120	60	236	78	12	108	605~720
1250A/3	825	356	280	105	322	353	220	11	50	120	70	246	78	12	108	605~720
1600A/3	825	356	280	105	322	353	220	11	50	120	80	246	78	12	108	605~720
1000A/4	1065	316	280	105	322	473	220	11	50	120	60	236	78	12	108	605~720
1250A/4	1065	356	280	105	322	473	220	11	50	120	70	246	78	12	108	605~720
1600A/4	1065	356	280	105	322	473	220	11	50	120	80	246	78	12	108	605~720

6.15 NH40-2000~3150/3S及NH40-2000~3150/4S外形与安装尺寸

图 17

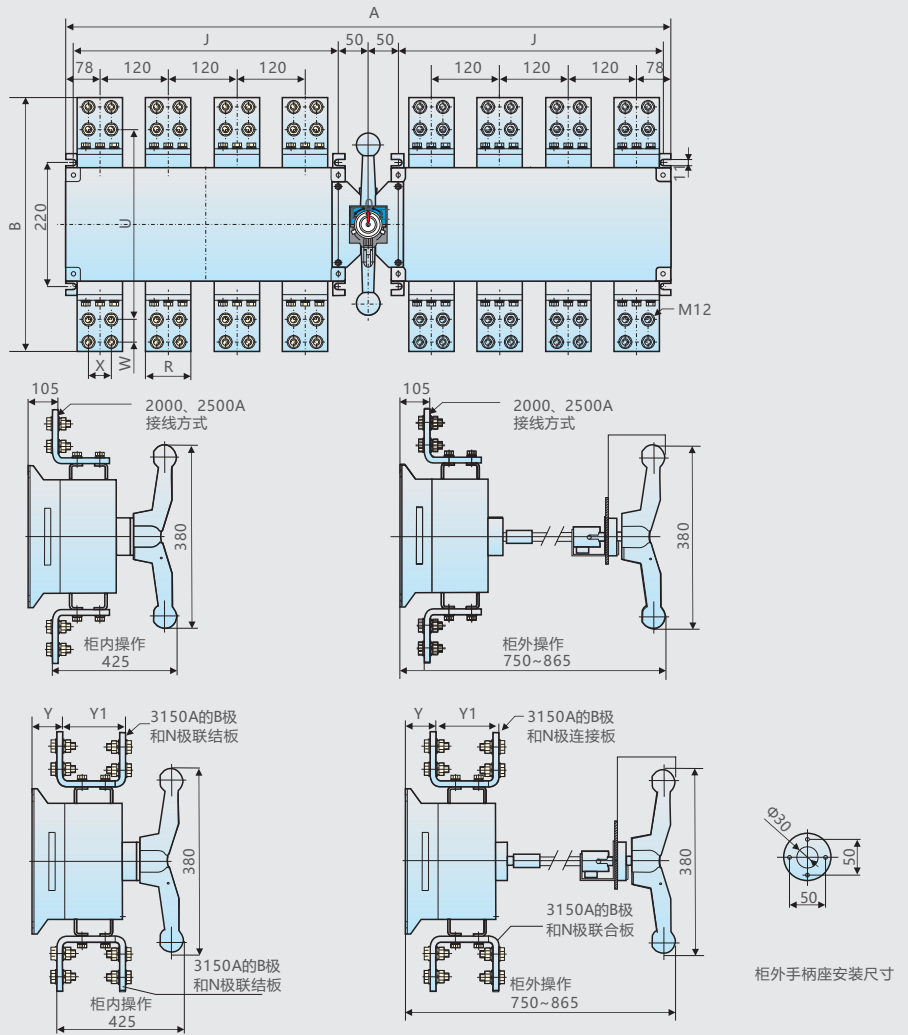
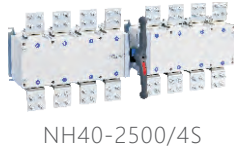

规格	A	B	J	R	U	Y	Y1	X	W
2000A/3	825	440	353	80	310	105	105	40	40
2500A/3	825	440	353	80	310	105	105	40	40
3150A/3	825	510	353	120	360	105	105	40	40
2000A/4	1065	440	473	80	310	105	105	40	40
2500A/4	1065	440	473	80	310	105	105	40	40
3150A/4	1065	510	473	120	360	105	105	40	40

6.16 NH40-□/□BC系列(第二代开关)外形及安装尺寸图

图 18

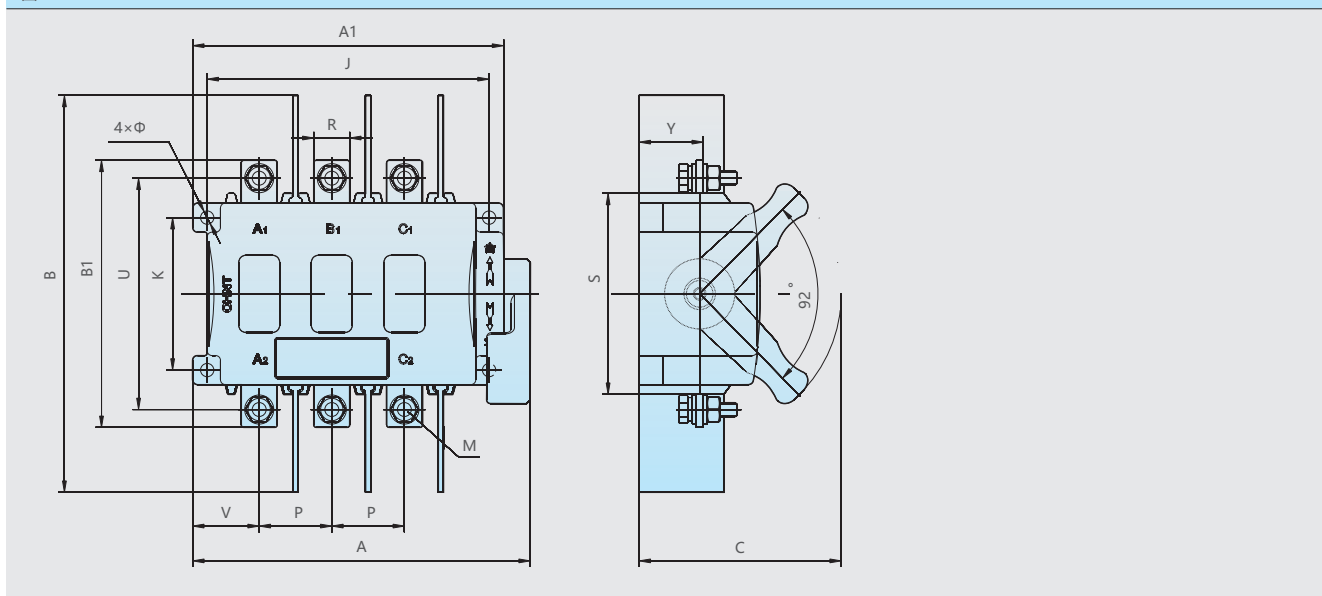

型号规格	A	A1	B	B1	C	J	K	M	P	R	S	U	V	Y	Φ
NH40-16-125/3BC	145	129	165	110	85	116	63	6	30	15	83	96	27.5	27	5.5
NH40-160-250/3BC	200	173	185	146	130	159	82	8	40	25	106	128	35	37	6.5
NH40-315/3BC	280	252	230	204	170	233	113	12	60	32	142	174	50	46	8.5
NH40-400/3BC	280	252	230	204	170	233	113	12	60	35	142	174	50	46	8.5
NH40-630/3BC	280	252	240	204	170	233	113	12	60	40	142	184	50	46	8.5
NH40-16-125/4BC	175	159	165	110	85	146	63	6	30	15	83	96	27.5	27	5.5
NH40-160-250/4BC	240	213	185	146	130	199	82	8	40	25	106	128	35	37	6.5
NH40-315/4BC	340	312	230	204	170	293	113	12	60	32	142	174	50	46	8.5
NH40-400/4BC	340	312	230	204	170	293	113	12	60	35	142	174	50	46	8.5
NH40-630/4BC	340	312	240	204	170	293	113	12	60	40	142	184	50	46	8.5

6.17 NH40-16~100/CSWH型双投开关及箱体安装尺寸

图 19



NH40-16~100/4CSWH



NH40-16~100/4CSWH

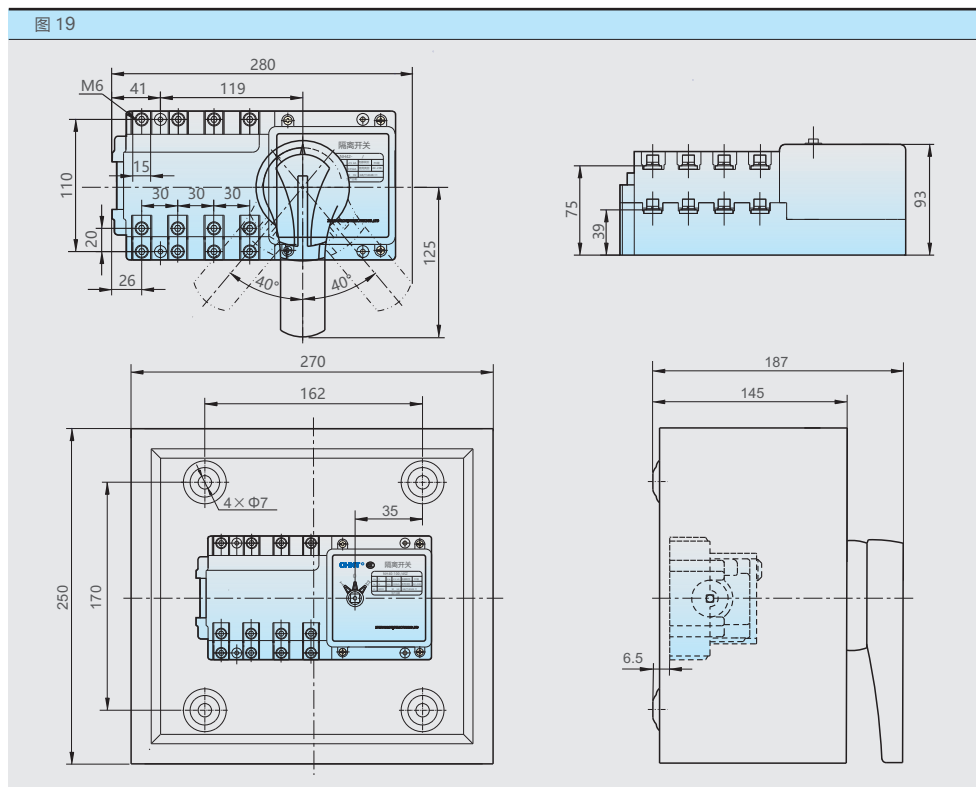

6.18 NH40-16~1600/CH、NH40-125~1600/CSH型开关本体及箱体安装尺寸

图 20



NH40-125、160/4CSWH



NH40-630/4CSWH



NH40-1600/4CSWH

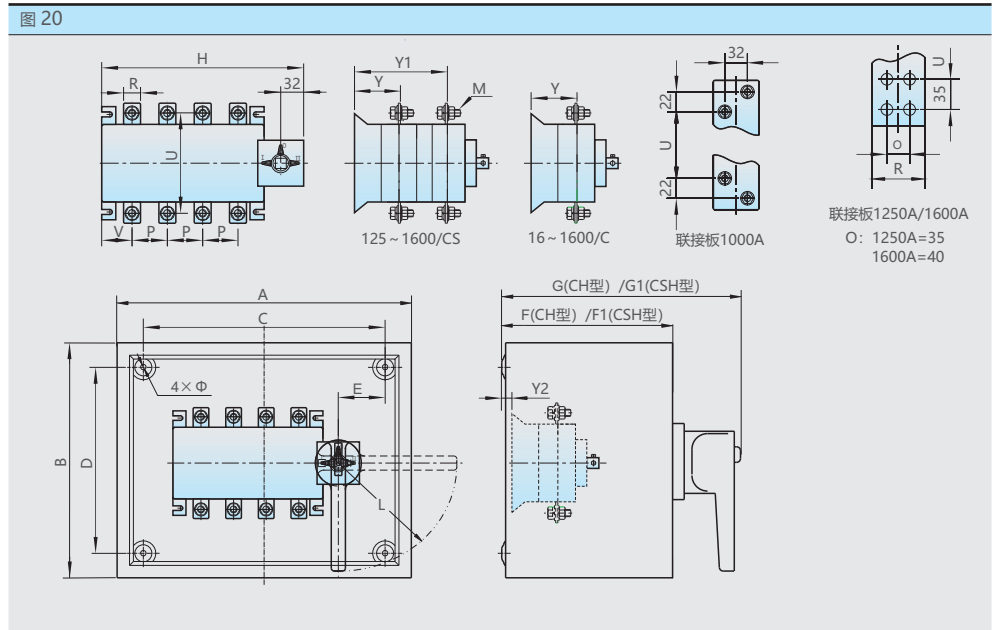

规格	NH40-16~1600/CH单投开关、NH40-125~1600/CSH双投开关本体及箱体安装尺寸(mm)																	
电流	A	B	C	D	E	F/F1	G/G1	H	P	L	R	U	V	M	Y	Y1	Y2	Φ
16A~100A/3	270	250	162	170	35	100/145	142/187	170	30	120	14	90	20	6	39	-	6.5	7
16A~100A/4	270	250	162	170	35	100/-	142/-	170	30	120	14	90	20	6	39	-	6.5	7
125A、160A/3	380	400	312	336	71	160/220	240/300	192	36	140	18(125A)/20(160A)	115	31	8	58	122	6.5	7
125A、160A/4	380	400	312	336	71	160/220	240/300	222	36	140	18(125A)/20(160A)	115	31	8	58	122	6.5	7
200A、250A/3	350	350	290	290	45	160/235	240/323	232	50	140	25	142	37	10	67	148	6.5	7
200A、250A/4	350	350	290	290	45	160/235	240/323	282	50	140	25	142	37	10	67	148	6.5	7
315A、400A/3	460	550	330	460	15	180/290	268/378	298	65	200	32(315A)/35(400A)	205	48	12	84	196	7	11
630A/3	460	550	330	460	15	180/290	268/378	298	65	200	40	220	48	12	84	196	7	11
315A、400A/4	460	550	330	460	15	180/290	268/378	358	65	200	32(315A)/35(400A)	205	48	12	84	196	7	11

规格	NH40-16~1600/CH单投开关、NH40-125~1600/CSH双投开关本体及箱体安装尺寸(mm)																	
电流	A	B	C	D	E	F/F1	G/G1	H	P	L	R	U	V	M	Y	Y1	Y2	Φ
630A/4	460	550	330	460	15	180/290	268/378	358	65	200	40	220	48	12	84	196	7	11
1000A/3	670	750	568	640	43	245/385	268/474	445	120	200	60	236	66	12	108	253	8	11
1250A/3	670	750	568	640	43	245/385	268/474	445	120	200	70	246	66	12	108	253	8	11
1600A/3	670	750	568	640	43	245/385	268/474	445	120	200	80	246	66	12	108	253	8	11
1000A/4	670	750	568	640	43	245/385	268/474	565	120	200	60	236	66	12	108	253	8	11
1250A/4	670	750	568	640	43	245/385	268/474	565	120	200	70	246	66	12	108	253	8	11
1600A/4	670	750	568	640	43	245/385	268/474	565	120	200	80	246	66	12	108	253	8	11

6.19 NH40-2000~3150/CH、NH40-2000~3150/CSH型开关本体及箱体安装尺寸

图 21



NH40-800~1600/4CSWH

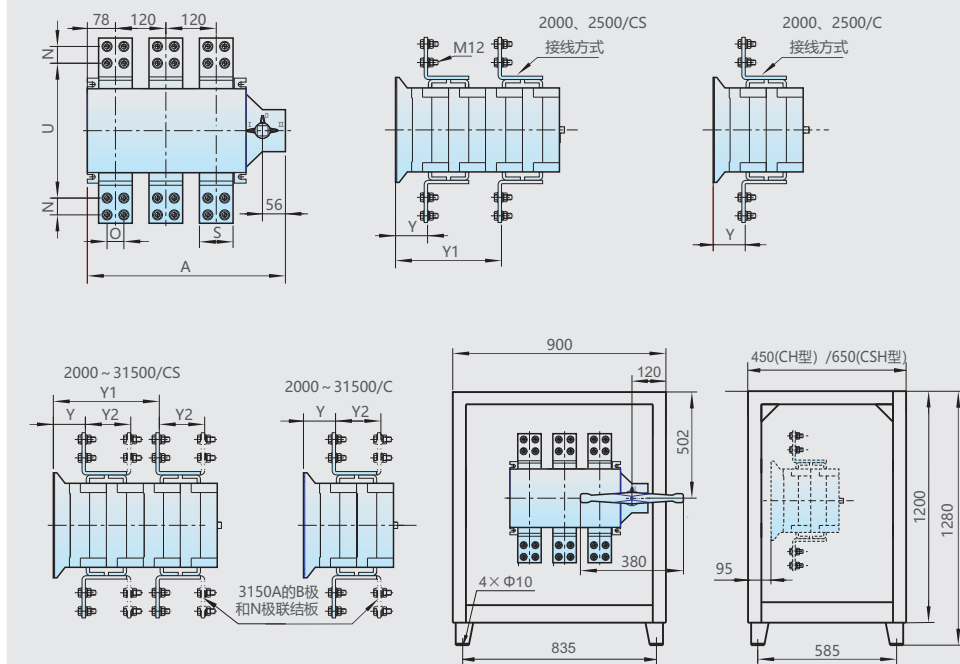

规格	NH40-2000~3150/CH 及 NH40-2000~3150/CSH安装尺寸(mm)							
电流	A	S	U	O	N	Y	Y1	Y2
2000A/3	472	80	310	40	40	105	335	-
2500A/3	472	80	310	40	40	105	335	-
3150A/3	472	120	360	50	50	105	335	105
2000A/4	592	80	310	40	40	105	335	-
2500A/4	592	80	310	40	40	105	335	-
3150A/4	592	120	360	50	50	105	335	105

6.20 NH40-16~630/BCH型(第二代产品)开关本体及箱体安装尺寸(mm)

图 22

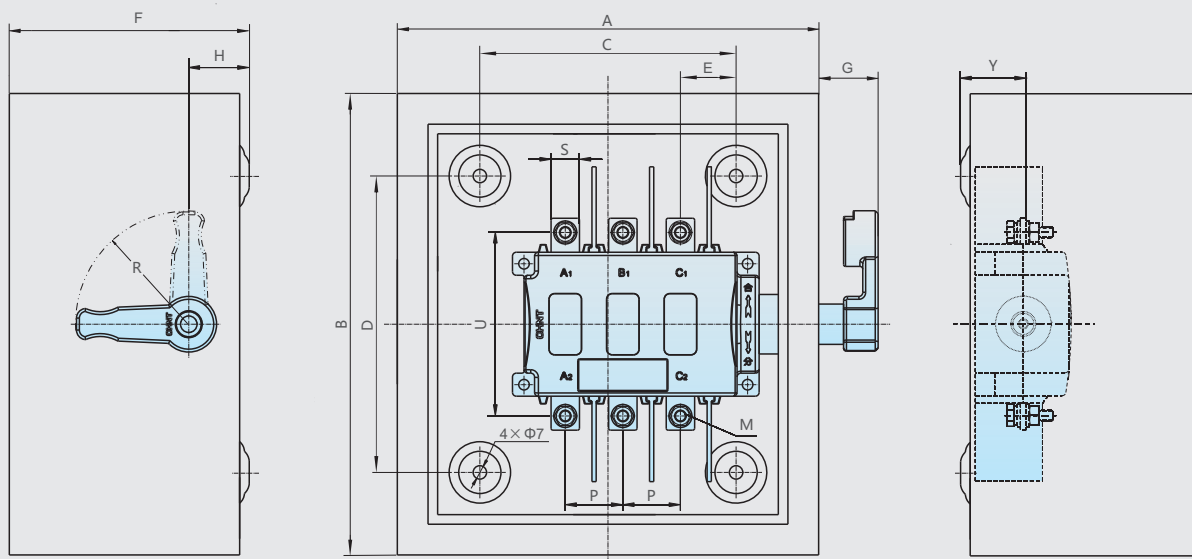

型号规格	A	B	C	D	E	F	G	H	M	R	S	U	P	Y
NH40-160-250/3BCH	264	278	178	192	46	135	52	42	8	94	25	128	40	43
NH40-315/3BCH	340	320	254	234	69	145	56	52	12	125	32	174	60	53
NH40-400/3BCH	340	320	254	234	69	145	56	52	12	125	35	174	60	53
NH40-630/3BCH	340	320	254	234	69	145	56	52	12	125	40	184	60	53
NH40-160-250/4BCH	264	278	178	192	46	135	52	42	8	94	25	128	40	43
NH40-315/4BCH	340	320	254	234	69	145	56	52	12	125	32	174	60	53
NH40-400/4BCH	340	320	254	234	69	145	56	52	12	125	35	174	60	53
NH40-630/4BCH	340	320	254	234	69	145	56	52	12	125	40	184	60	53

7 使用维护

- 7.1 安装前应检查开关是否完好、操作灵活。
- 7.2 工作条件应符合3.1~3.5的规定。
- 7.3 开关应定期维护调整，清除污物，保持清洁，使触头在良好的接触状态下工作。

8 订货须知

订购时用户应提供开关型号、电压等级、电流等级，极数及数量等，特殊订货请咨询我公司技术部门。

例：NH40-250/3，10台；或NH40-250/3W，10台。

X-ON Electronics

Largest Supplier of Electrical and Electronic Components

Click to view similar products for [CHINT](#) manufacturer:

Other Similar products are found below :

[710037400000004](#) [AL-X3](#) [AX-3X/20](#) [AX-3X/31](#) [AX-X3](#) [BH-0.66 30 I 150/5A](#) [BH-0.66 30 I 250/5A](#) [BH-0.66 30 I 400/5A](#) [BH-0.66 30 I 75/5A](#) [BH-0.66 30 I B 100/5A](#) [BH-0.66 30 I B 75/5A](#) [BH-0.66 40 I 250/5A](#) [BH-0.66 40 I 300/5A](#) [BH-0.66 40 I 400/5A](#) [BH-0.66 40 I 500/5A](#) [BH-0.66 40 I 600/5A](#) [BH-0.66 40 I 750/5A](#) [BH-0.66 50 I 300/5A](#) [BH-0.66 50 I 400/5A](#) [BH-0.66 50 I 500/5A](#) [BH-0.66 50 I 600/5A](#) [BH-0.66 50 I 800/5A](#) [BH-0.66 60 I 600/5A](#) [BH-0.66 60 I 800/5A](#) [BH-0.66 80 I 1000/5A](#) [BZMJ 0.415-15-3](#) [BZMJ 0.415-30-3](#) [BZMJ 0.4-20-3](#) [BZMJ 0.4-30-3](#) [BZMJ 0.45-10-3](#) [BZMJ 0.45-15-3](#) [BZMJ 0.45-20-3](#) [BZMJ 0.45-25-3](#) [BZMJ 0.45-30-3](#) [BZMJ 0.45-50-3](#) [BZMJ 0.45-5-3](#) [CJ19-3211 220V](#) [CJ19-3211 380V](#) [CJ19-4311 220V](#) [CJ19-63/21 220V](#) [CJ19-63/21 380V](#) [CJ20-16 220V](#) [CJ20-16 380V](#) [CJ20-25 220V](#) [CJ20-40 220V](#) [CJ20-40 380V](#) [CJ20-63 220V](#) [CJ20-63 380V](#) [CJT1-10 220V](#) [CJT1-10 36V](#)