

Sync. Rectifier Step Up Converter

General Description

The AP2007 is a compact, high-efficiency, synchronous step-up converter with power Mosfets embedded and with output turn off true shutdown function for a single-cell Li-ion/polymer battery. The AP2007 uses only 70 μ A (typ) quiescent current and allows the converter to switch only when needed at no load and light loads, and when load is higher than 150mA, it uses fixed-frequency PWM technique at 1MHz. It features a current mode control for fast transient response with internal compensation. The AP2007 includes cycle-by-cycle current limit to maximum inductor current and over-temperature protection circuit. The AP2007 is suitable for iPad-like computers, smart phones and portable handheld devices.

The AP2007 is available in a SOP8-PP package. The operating temperature range is from -45°C to +85°C.

- Low 70 μ A Quiescent Current
- Guaranteed 2A Output Current at VOUT = 5V from 3.3V Input
- 1MHz PWM Switching Frequency
- Synchronous and Embedded Power Mosfets
- No Schottky Diode Required
- Internal Soft-Start to Limit Inrush Current
- Adjustable Output
- Output turn off true shutdown function
- Current Mode Operation with Internal Compensation
- For Excellent Line and Load Transient Response
- Overload/Short-Circuit Protection
- Shutdown Current <1 μ A
- Thermal Shutdown
- Compact 8 pin,SOP8-PP package

Applications

- iPad-like computers, smart phones and portable handheld devices.

Features

- Up to 90% Efficiency at Iout=2A VOUT = 5V from 3.6V Input

Package

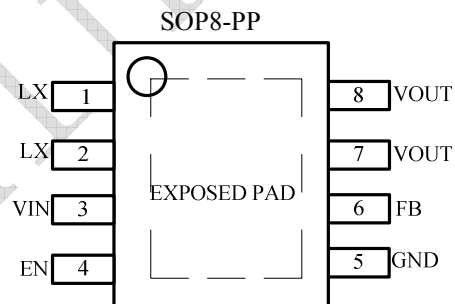

Typical Application Circuit

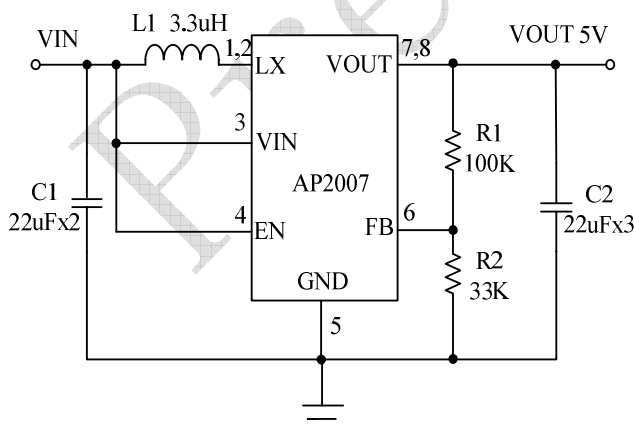

Figure 1. Basic Application Circuit with AP2007

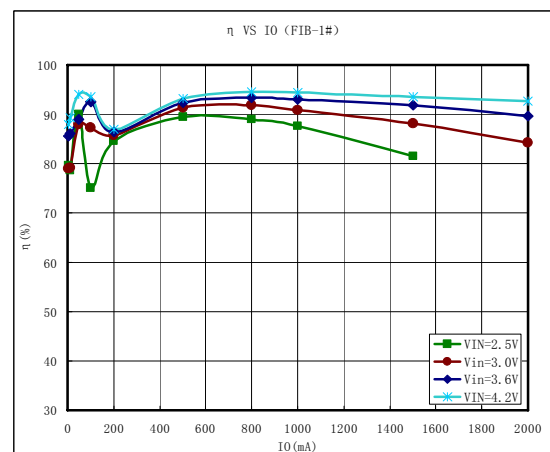

Figure 2. Typical Efficiency Curve

Pin Description

Pin No.	Pin Name	Pin Function
1,2	LX	Inductor Node.
3	VIN	IC Power Supply Input.
4	EN	Enable pin for the IC. Drive this pin high to enable the part, low to disable.
5	GND	IC Analog Ground.
6	FB	Converter Feedback Input.
7,8	VOUT	Converter Output.
	EP	Exposed Paddle. Connect to the ground plane to optimize thermal performance. EP is internally connected to GND. EP must be connected to GND at a single point with a star ground connection.

Functional Block Diagram

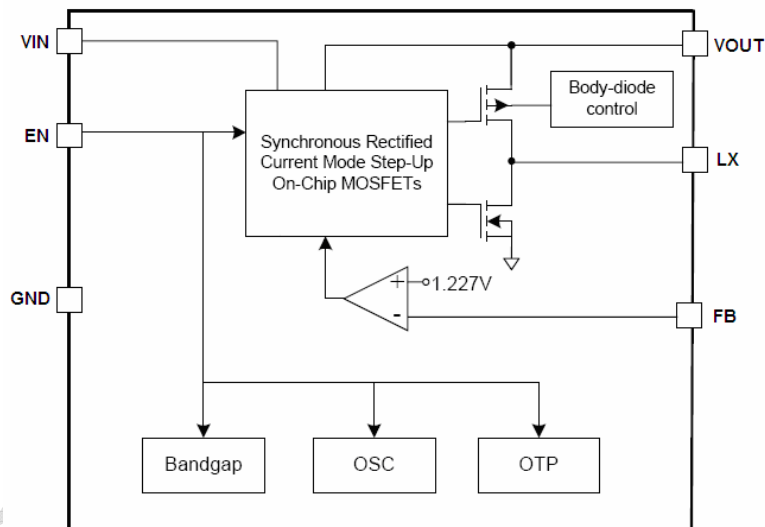

Figure 3. AP2007 Block Diagram

Absolute Maximum Rating ^(Note 1)

Input Supply Voltage.....	-0.3V to +6V
LX Voltage.....	-0.3V to +6V
VOUT Voltages.....	-0.3V to +6V
FB Voltages.....	-0.3V to +6V
VIN Voltages.....	-0.3V to +6V
EN Voltages.....	-0.3V to +6V

(Note 2)

Package Thermal Resistance

θ_{JA}	50°C/W
θ_{JC}	10°C/W

Operating Temperature Range.....-40°C to +85°C
 Storage Temperature Range.....-65°C to +150°C
 Lead Temperature (Soldering, 10s).....+260°C

Electrical Characteristics ^(Note 3)

(V_{OUT}=5V, V_{IN} = 3.6V, T_A = 25°C, Test Circuit of Figure 1, unless otherwise noted.)

Parameter	Symbol	Test Conditions	Min	Typ	Max	Unit
Input operation voltage	V _{IN}		2.5		5	V
Output voltage	V _{OUT}	Line and Load Regulation in CCM (I _L >100mA) V _{IN} =2.5V~4.5V	4.925	5	5.075	V
Input Quiescent current	I _{IN}	V _{IN} =3.6V FB=1.28V No load, no switching (exclude input current from EN)		50	70	uA
Shutdown supply current	I _{IN}	EN=0		0.1	1	uA
Switching Frequency	F _{osc}		0.7	1	1.3	MHz
Soft-Start Interval	SS			0.2		ms
FB Regulation Voltage	V _{FB}		1.208	1.227	1.246	V
FB Input Current	I _{FB}	FB=1.0V			100	nA
Maximum Duty Cycle	D _{max}	FB=0.95V	86	93	96	%
V _{OUT} Leakage Current	IP _{VOUT_LK}	EN=0 , V _{OUT} =5V		1	5	uA
LX Leakage Current	IL _{X_LK}	EN=0 , V _{OUT} =5V		1	5	uA
Switch ON Resistance	RON-N			52	70	mΩ
	RON-P			49	65	mΩ
Peak Current Limit	I _{LIM}			5		A
Efficiency		EN=1, V _{IN} =3V, V _{OUT} =5V, I _{OUT} =2A		87		%
Thermal Shutdown Threshold		Rising Edge, 20°C hysteresis		150		°C
EN Input High Level	V _{ih_EN}		1.5		5.5	V
EN Input Low Level	V _{il_EN}		0		0.5	V
EN Internal Pull-Low Resistance	R _{in_EN}		200	250	300	kΩ

Note 1: Absolute Maximum Ratings are those values beyond which the life of a device may be impaired.

Note 2: Thermal Resistance is specified with approximately 1 square of 1oz copper.

Note 3: 100% production test at +25°C. Specifications over the temperature range are guaranteed by design and characterization.

Typical Performance Characteristics

Operation (CH1=VIN,CH2=VO,CH3=LX,CH4=ILX)
IO=0

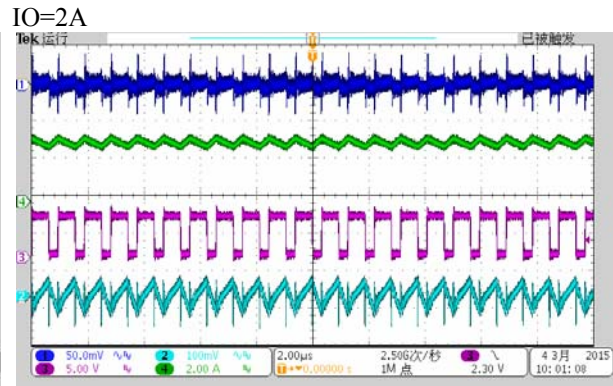
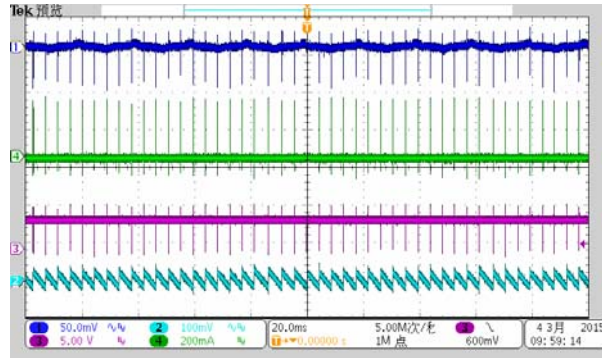

Start Up (CH1=EN,CH2=VO,CH3=LX,CH4=ILX) IO=0

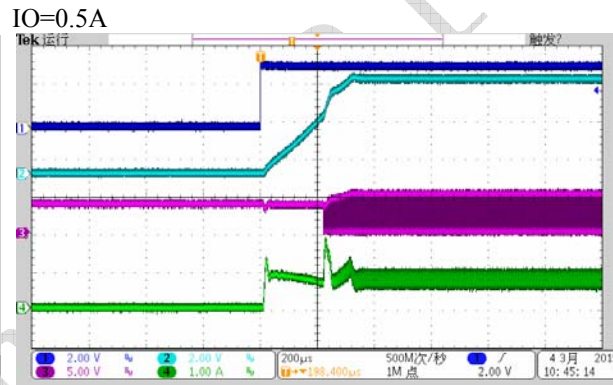
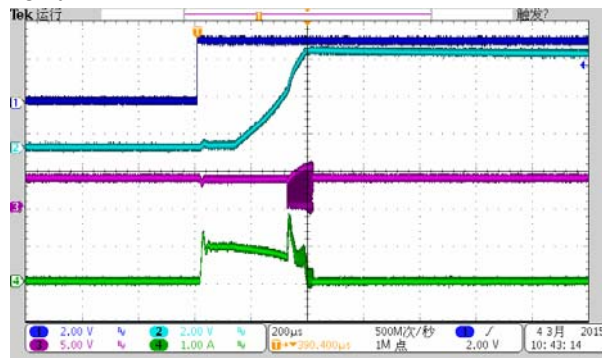

Over Current (CH1=LX,CH2=VO,CH4=ILX)

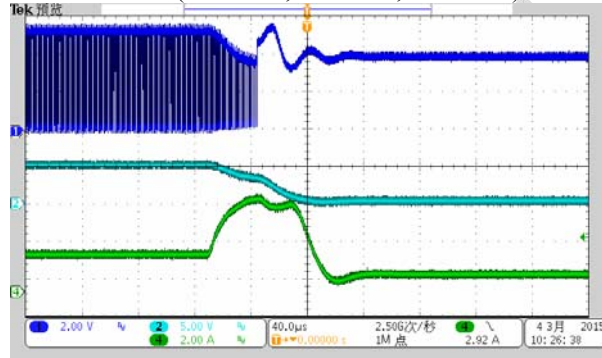

Short Circuit (CH1=LX,CH2=VO,CH4=ILX)

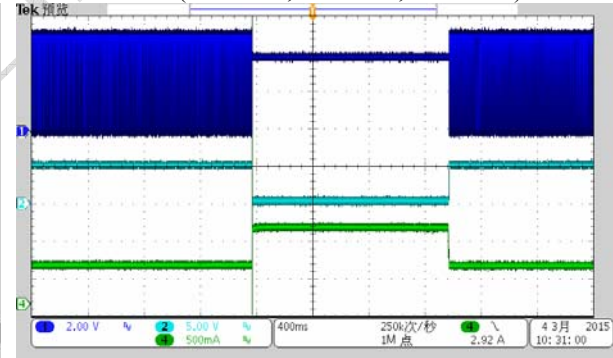

Load Transient Response (CH2=VO,CH4=IO) IO=0.2-1.5A

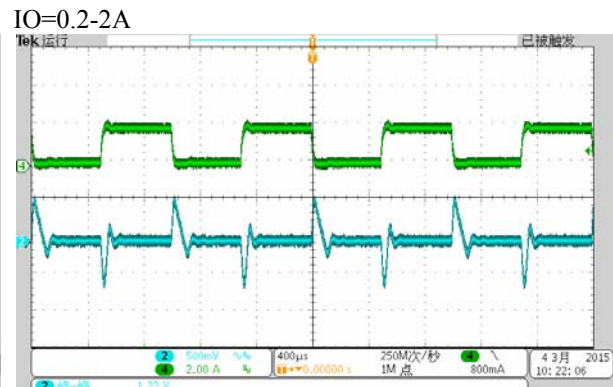
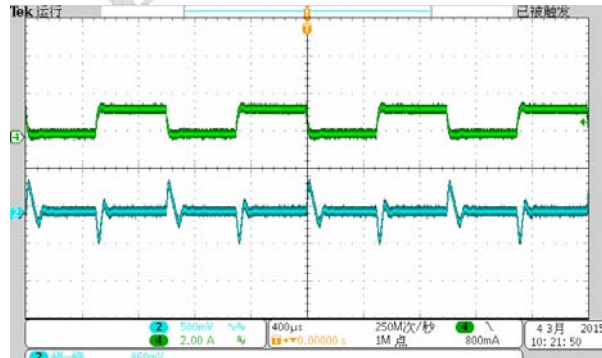

Ordering Information

Part number	Mark	Package
AP2007SPER	AP2007 YYWWP ¹	SOP8-PP

1. YYWW=date code

P= Package factory

Operation

The AP2007 current-mode step-up DC-DC switching converter uses a fixed-frequency PWM architecture with output shutdown. In light-load mode, the converter switches when needed, consuming only 70 μ A of quiescent current. In heavy-load mode of higher than 150mA, the converter switches every cycle at a constant frequency as fixed-PWM, thus enabling noise filtering. The AP2007 is highly efficient, with internal and synchronous switches. Shutdown reduces the quiescent current to less than 0.1 μ A. Low quiescent current and high efficiency make this device ideal for portable equipment.

The AP2007 step-up DC-DC switching converter typically generates a 5V output voltage from a single-cell battery input voltage. The minimum output peak current limit is 5A in SOP8-PP package. When an over-current, short-circuit or thermal shutdown condition is encountered. The converter will turn off until the over-current or over-temperature condition is removed. The AP2007 is adjustable by 2 external resistors with calculating the value for R1 as $R1 = R2 (VOUT/VFB - 1)$.

The AP2007 switches at a 1MHz frequency, allowing for tiny external components. The AP2007 is optimized for use in iPad-like computers, smart phones, portable handheld devices and other applications requiring low quiescent current for maximum battery life.

Package Information

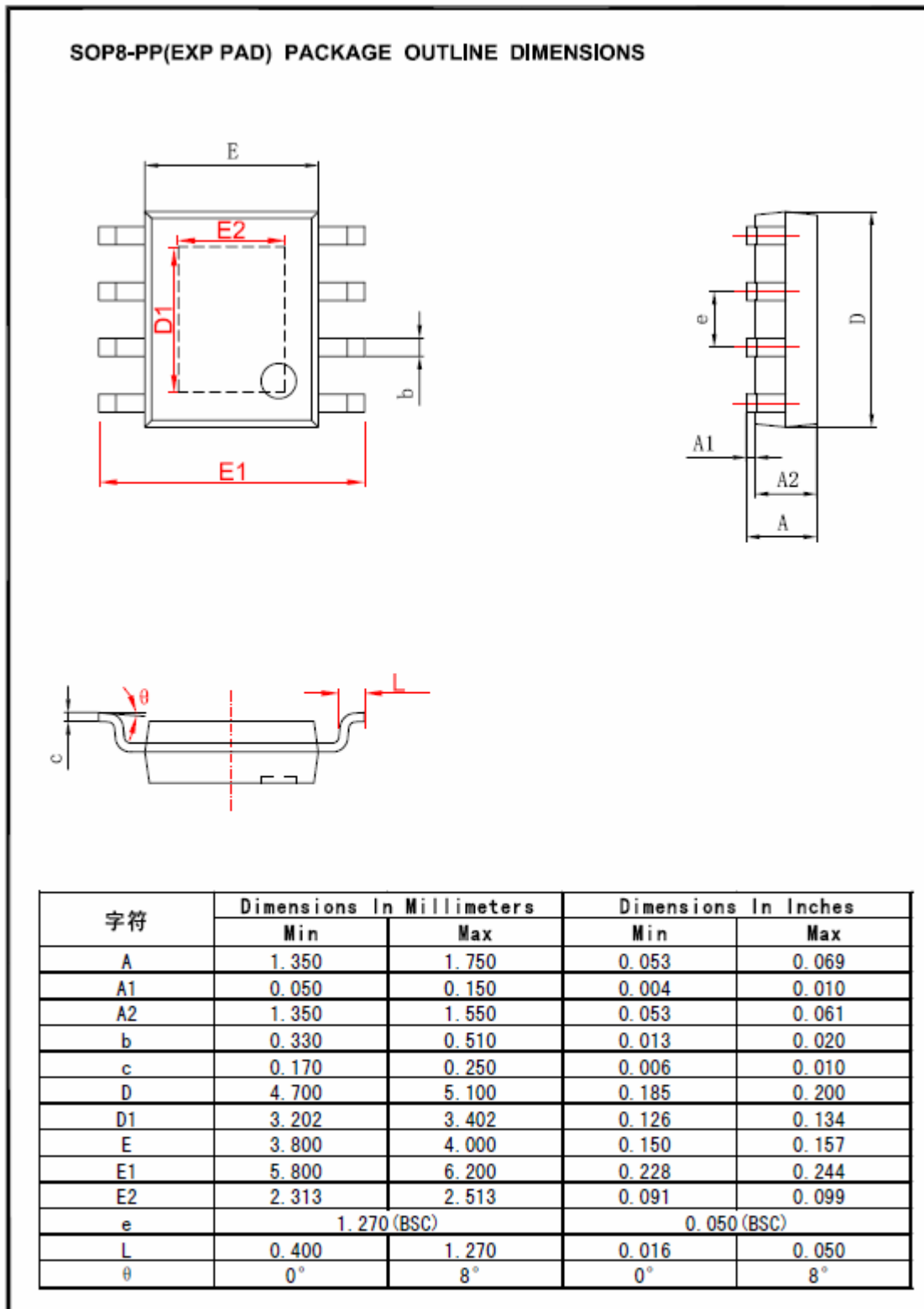

Important Notice

Chipown Microelectronics Co. Ltd. reserves the right to make changes without further notice to any products or specifications herein. Chipown Microelectronics Co. Ltd. does not assume any responsibility for use of any its products for any particular purpose, nor does Chipown Microelectronics Co. Ltd assume any liability arising out of the application or use of any its products or circuits. Chipown Microelectronics Co. Ltd does not convey any license under its patent rights or other rights nor the rights of others.

Preliminary

X-ON Electronics

Largest Supplier of Electrical and Electronic Components

Click to view similar products for [Isolated DC/DC Converters](#) category:

Click to view products by [Chipown](#) manufacturer:

Other Similar products are found below :

[FMD15.24G](#) [PSL486-7LR](#) [Q48T30020-NBB0](#) [18362](#) [JAHW100Y1](#) [SPB05C-12](#) [SQ24S15033-PS0S](#) [19-130041](#) [CE-1003](#) [CE-1004](#)
[RDS180245](#) [MAU228](#) [J80-0041NL](#) [DFC15U48D15](#) [XGS-1205](#) [NCT1000N040R050B](#) [SPB05B-15](#) [SPB05C-15](#) [L-DA20](#) [DCG40-5G](#)
[QME48T40033-PGB0](#) [AK1601-9RT](#) [DPA423R](#) [VI-R5022-EXWW](#) [PSC128-7iR](#) [RPS8-350ATX-XE](#) [DAS1004812](#) [PQA30-D24-S24-DH](#) [vi-](#)
[m13-cw-03](#) [VI-LN2-EW](#) [VI-PJW01-CZY](#) [CK2540-9ERT](#) [AK-1615-7R](#) [700DNC40-CON-KIT-8G](#) [350DNC40-CON-KIT-9G](#) [088-101348-G](#)
[VI-L52-EW](#) [VI-L53-CV](#) [PQA30-D48-S12-TH](#) [VI-L50-IY](#) [VI-LC63-EV](#) [AM2D-051212DZ](#) [24IBX15-50-0ZG](#) [HZZ01204-G](#) [SPU02L-09](#)
[SPU02M-09](#) [SPU02N-09](#) [UNO-PS/350-900DC/24DC/60W](#) [QUINT4-BUFFER/24DC/20](#) [QUINT4-CAP/24DC/5/4KJ](#)