

Standalone Linear Li-Ion Battery Charger with Thermal Regulation in SOT

General Description

The AP5054H is a complete constant current & constant voltage linear charger for single cell lithium-ion batteries. Its SOT package and low external component count make the AP5054H ideally suited for portable applications. Furthermore, the AP5054H is specifically designed to work within USB power specifications.

No external sense resistor is needed, and no blocking diode is required due to the internal MOSFET architecture. Thermal feedback regulates the charge current to limit the die temperature during high power operation or high ambient temperature. The charge voltage is fixed at 4.2V, and the charge current can be programmed externally with a single resistor. The AP5054H automatically terminates the charge cycle when the charge current drops to 1/10th the programmed value after the final float voltage is reached.

When the input supply (wall adapter or USB supply) is removed, the AP5054H automatically enters a low current state, dropping the battery drain current to less than 0.5 μ A. The AP5054H can be put into shutdown mode, reducing the supply current to 180 μ A.

Other features include charge current monitor, under-voltage lockout, automatic recharge and status indication.

Applications

- Cellular Telephones, PDAs, MP3 /MP4 Players
- Charger
- Digital Camera
- Electronic Dictionary
- Bluetooth ,GPS Applications

Typical Application Circuit

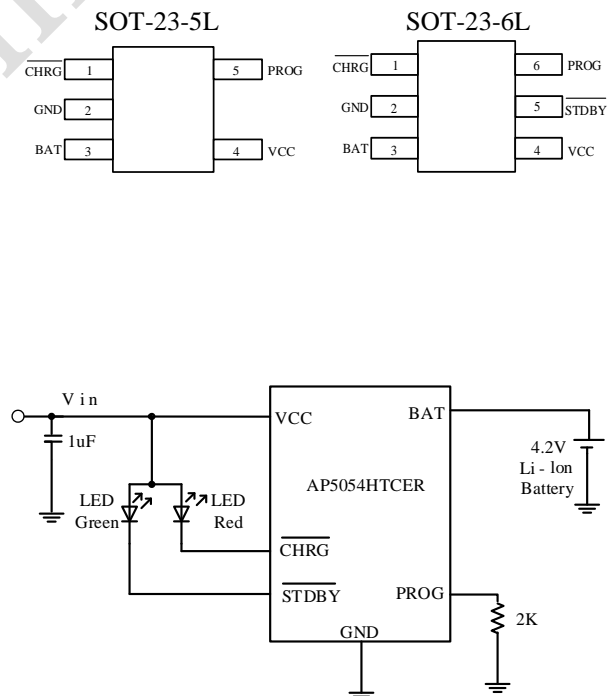
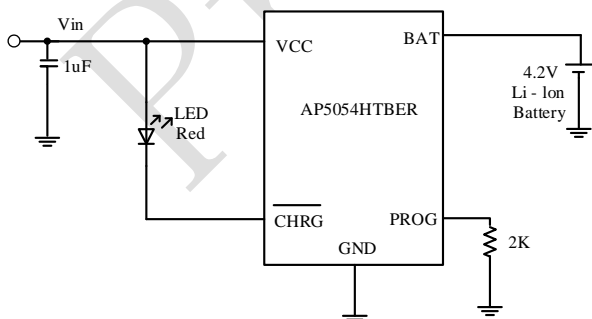

Features

- Input Voltage up to 20V
- Input Over Voltage Protection: 6.1V
- Programmable Charge Current Up to 750mA
- No MOSFET, Sense Resistor or Blocking Diode Required
- Constant-Current/Constant-Voltage Operation with Thermal Regulation to Maximize Charge Rate Without Risk of Overheating
- Charges Single Cell Li-Ion Batteries Directly from USB Port
- Preset 4.2V Charge Voltage
- Charge Current Monitor Output for Gas Gauging
- Automatic Recharge
- Charge state pairs of output, no battery and fault status display
- C/10 Charge Termination
- 180 μ A Supply Current in Shutdown
- 2.9V Trickle Charge Threshold
- Soft-Start Limits Inrush Current
- Available in SOT23 Package

Package

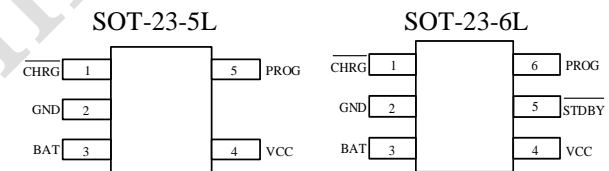

Pin Description

Pin No.		Pin Name	Pin Function
SOT-23-5L	SOT-23-6L		
1	1	CHRG	Open-Drain Charge Status Output.
2	2	GND	Ground.
3	3	BAT	Charge Current Output.
4	4	VCC	Positive Input Supply Voltage.
-	5	STDBY	The completion of battery charging instructions side.
5	6	PROG	Charge Current Program, Charge Current Monitor and Shutdown Pin.

Functional Block Diagram

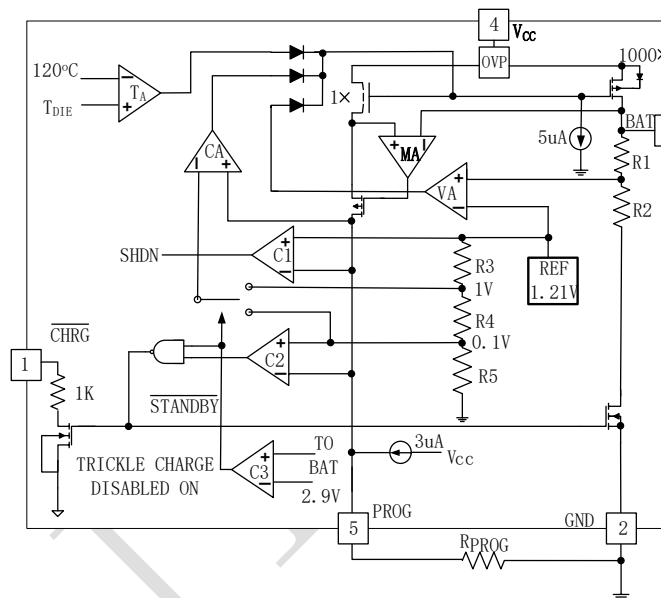

Figure 1. Block Diagram(AP5054HTBER)

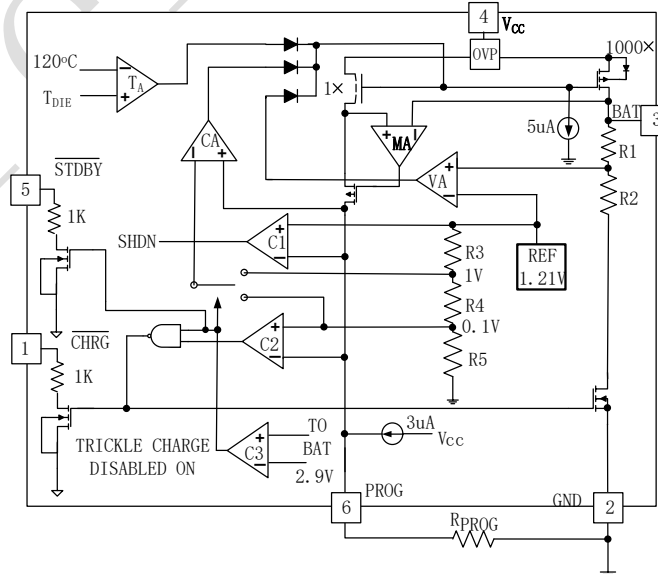

Figure 2. Block Diagram(AP5054HTCER)

Absolute Maximum Ratings

PARAMETER	SYMBOL	MAXIMUM RATING	UNIT
Input Supply Voltage	V _{cc}	V _{SS} -0.3~V _{SS} +20	V
PROG pin Voltage	V _{prog}	V _{SS} -0.3~5.5+0.3	
BAT pin Voltage	V _{bat}	V _{SS} -0.3~8	
CHRG pin Voltage	V _{chrg}	V _{SS} -0.3~V _{SS} +8	
STDBY pin Voltage	V _{stdby}	V _{SS} -0.3~V _{SS} +8	
BAT pin Current	I _{bat}	750	mA
PROG pin Current	I _{prog}	750	μA
Operating Ambient Temperature	Topa	-40~+85	°C
Storage Temperature	Tstr	-65~+125	
Lead Temperature (Soldering, 10s)		260	

Caution: The absolute maximum ratings are rated values exceeding which the product could suffer physical damage. These values must therefore not be exceeded under any conditions.

Electrical Characteristics

Parameter	Symbol	CONDITION	MIN	TYP	MAX	UNIT
Input supply voltage	V _{cc1}		4.25		20	V
Operation Voltage	V _{cc2}		4.25		5.5	V
Input Voltage OVP	V _{OVP}	V _{CC} Rising	5.8	6.1	6.4	V
OVP Hysteresis	V _{OVP-HYS}			0.25		V
Input supply current	I _{cc}	Charge mode, R _{PROG} =10K		350		μA
		Standby mode		150	500	μA
		Shutdown mode(R _{PROG} NOT connected, V _{cc} <V _{bat} or V _{cc} <V _{uv})		180		μA
Regulated Output Voltage	V _{float}	T _A =25°C, I _{BAT} = 40mA	4.16		4.24	V
BAT pin Current	I _{bat}	R _{PROG} =10k, Current mode	85	100	110	mA
		R _{PROG} =2k, Current mode	465	500	530	mA
		Standby mode, V _{bat} =4.3V	0	-2.5	-6	μA
		Shutdown mode		-1	-2.5	μA
		Sleep mode, V _{cc} =0V		-0.05	-0.5	μA
Trickle charge current	I _{trikl}	V _{bat} <V _{trikl} , R _{prog} =2k	135	150	180	mA
Trickle charge Threshold Voltage	V _{trikl}	R _{PROG} =10K, V _{bat} Rising	2.78	2.9	3.05	V
Trickle voltage hysteresis voltage	V _{trhys}	R _{PROG} =10k	100	135	250	mV
V _{cc} Undervoltage lockout Threshold	V _{uv}	From V _{cc} low to high	3.6	3.8	4.05	V
V _{cc} undervoltage lockout hysteresis	V _{uvhys}		150	200	300	mV
V _{cc} -V _{bat} Lockout Threshold voltage	V _{asd}	V _{cc} from low to high	45	280	400	mV
		V _{cc} from high to low	5	100	230	mV
C/10 Termination Current	I _{term}	R _{PROG} =10k		0.06		mA/mA

Threshold		$R_{PROG}=2k$		0.10		mA/mA
PROG pin Voltage	V_{prog}	$R_{PROG}=10k$, Current mode	0.93	1.0	1.07	V
CHRG pin Output low voltage	V_{chrg}	$I_{chrg}=1mA$		1.2	1.5	V
STDBY pin Output low voltage	V_{stdby}	$I_{stdby}=1mA$		1.2	1.5	V
Recharge Battery threshold Voltage	ΔV_{recg}	$V_{FLOAT} - V_{RECHRG}$	80	160	280	mV
Limited temperature patterns in the junction temperature	T_{lim}			145		$^{\circ}C$

Typical Performance Characteristics

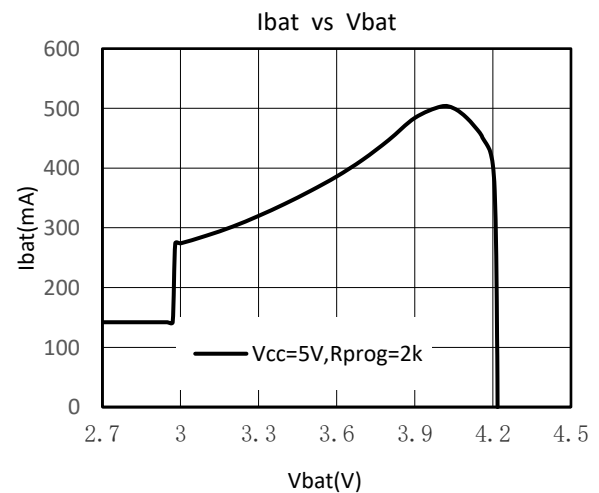
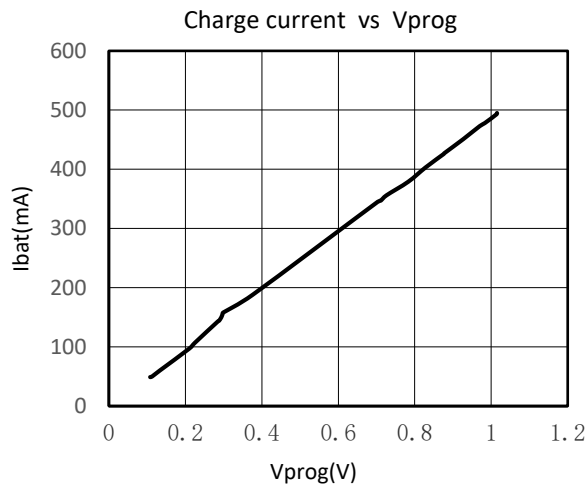
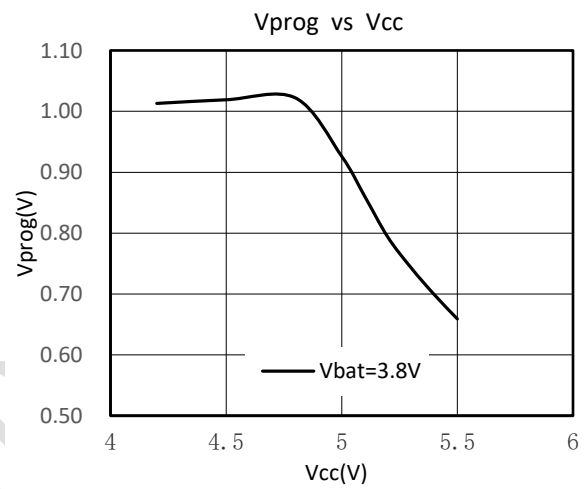
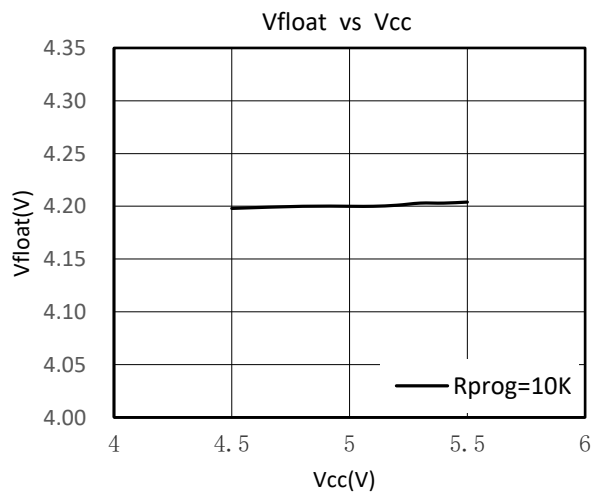

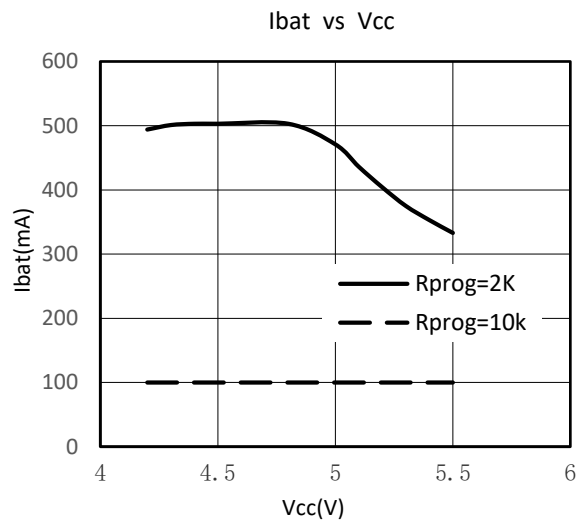
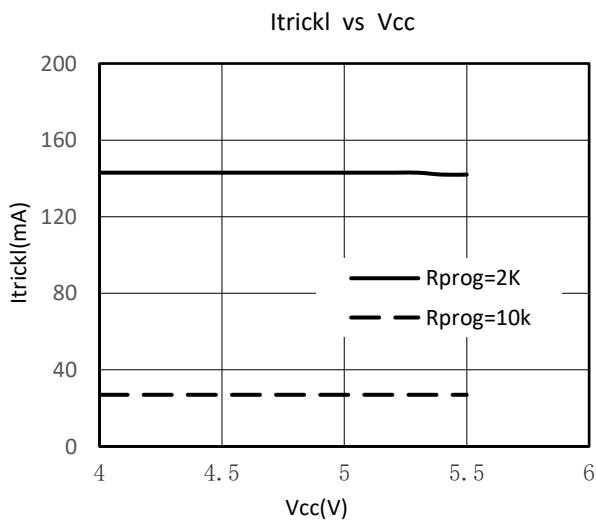

Ordering Information

Part Numbers	Marks	Packages
AP5054HTBER	K5YWW ¹	SOT-23-5L
AP5054HTCER	K5YWW ¹	SOT-23-6L

1.YWW= date code

Pin Function

CHRG : Open-Drain Charge Status Output. When the battery is charging, the CHRG pin is pulled low by an internal N-channel MOSFET. When the AP5054H detects an under voltage lockout condition and the charge cycle is completed, CHRG is forced high impedance.

GND: Ground.

BAT: Charge Current Output. Provides charge current to the battery and regulates the final float voltage to 4.2V. An internal precision resistor divider from this pin sets the float voltage which is disconnected in shutdown mode.

VCC: Positive Input Supply Voltage. Provides power to the charger, VCC range from 4.25V to 20V and operation voltage from 4.25V to 5.5V. VCC pin should be bypassed with at least a 1 μ F capacitor. When VCC drops to within 30mV of the BAT pin voltage, the AP5054H enters shutdown mode, dropping I_{BAT} to less than 2 μ A.

STDBY(AP5054HTBER): The completion of battery charging instructions side. When the battery charge is complete, STDBY pulled low by internal switches, indicating the completion of charging. In addition, STDBY pin will be in a high-impedance state.

PROG: Charge Current Program, Charge Current Monitor and Shutdown Pin. The charge current is programmed by connecting a 1% resistor, R_{PROG}, to ground. When charging in trickle-current mode, this pin servos to 0.1V. When charging in constant-current mode, this pin servos to 1V. In all modes, the voltage on this pin can be used to measure the charge current using the following formula:

$$I_{BAT} = (V_{PROG}/R_{PROG}) \cdot 1000.$$

The P_{ROG} pin can also be used to shut down the charger. Disconnecting the program resistor from ground allows a 3 μ A current to pull the P_{ROG} pin high. When it reaches the 1.21V shutdown threshold voltage, the charger enters shutdown mode, charging stops and the input supply current drops to 180 μ A. This pin is also clamped to approximately 2.4V. Driving this pin to voltages beyond the clamp voltage will draw currents as high as 1.5mA. Reconnecting R_{PROG} to ground will return the charger to normal operation.

Package Information

SOT-23-5L

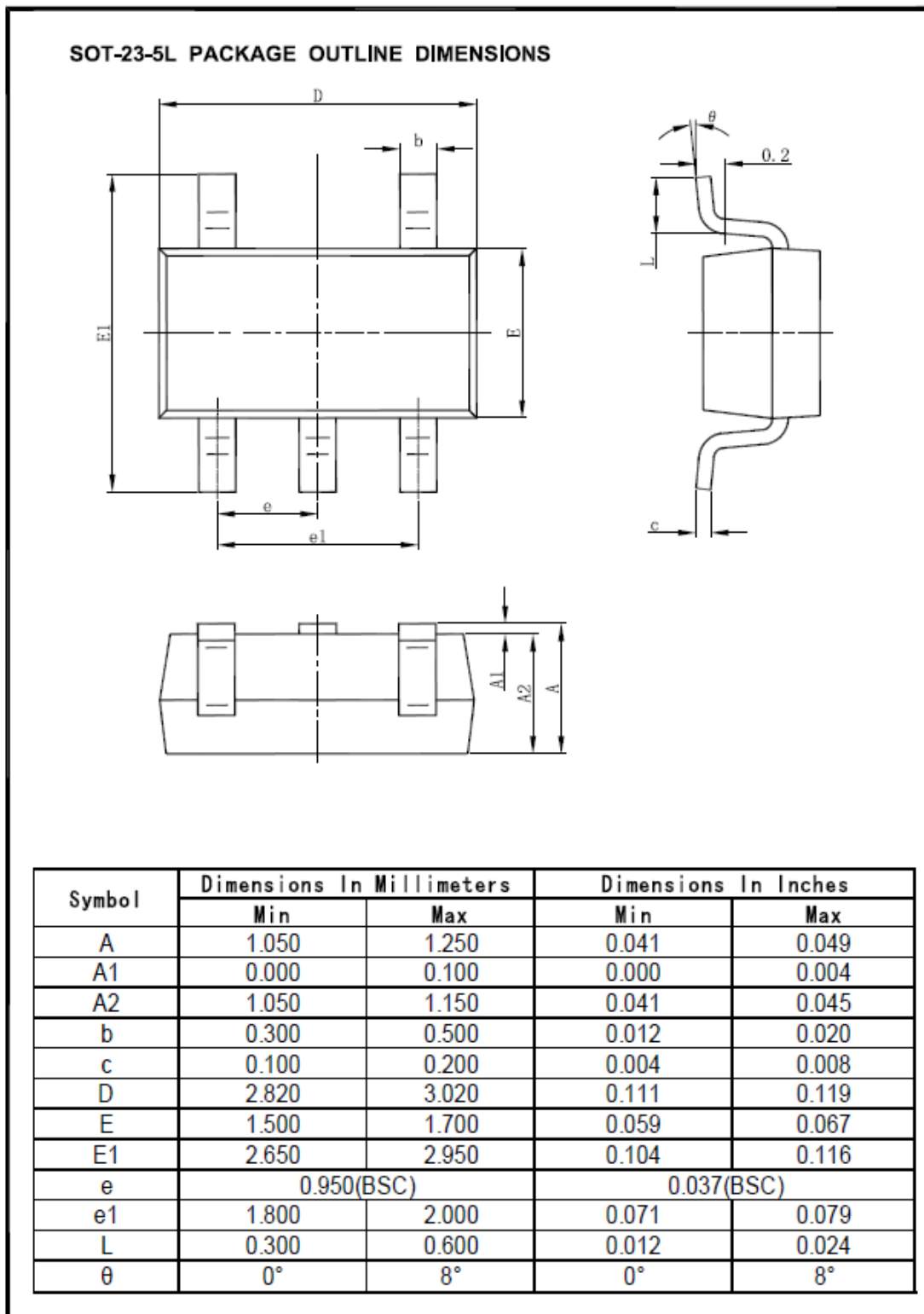

SOT-23-6L

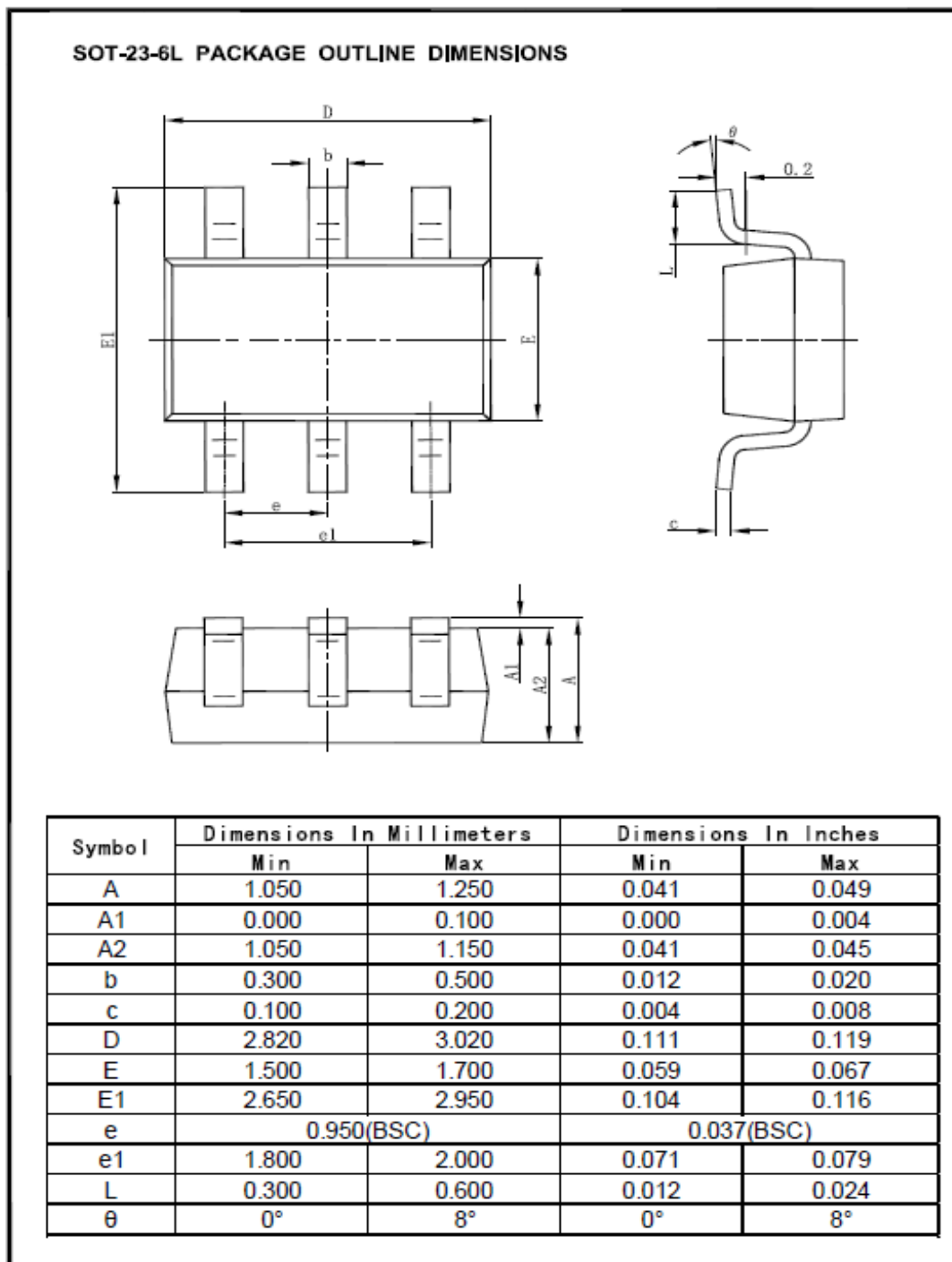

Important Notice

Chipown Microelectronics Co. Ltd. reserves the right to make changes without further notice to any products or specifications herein. Chipown Microelectronics Co. Ltd. does not assume any responsibility for use of any its products for any particular purpose, nor does Chipown Microelectronics Co. Ltd assume any liability arising out of the application or use of any its products or circuits. Chipown Microelectronics Co. Ltd does not convey any license under its patent rights or other rights nor the rights of others.

Preliminary

X-ON Electronics

Largest Supplier of Electrical and Electronic Components

Click to view similar products for [Battery Management](#) category:

Click to view products by [Chipown](#) manufacturer:

Other Similar products are found below :

[VN5R003HTR-E](#) [NCP1855FCCT1G](#) [FAN54063UCX](#) [LC05132C01NMTTGG](#) [ISL78714ANZ](#) [CM1104-EH](#) [CM1104-DBB](#) [CM1104-MBB](#)
[XC6801A421MR-G](#) [ISL95521BHRZ](#) [ISL95521BIRZ](#) [MP2639AGR-P](#) [S-82D1AAE-A8T2U7](#) [S-82D1AAA-A8T2U7](#) [S-8224ABA-I8T1U](#)
[MC33772CTC0AE](#) [BQ28Z610DRZR-R1](#) [MCP73832-4ADI/MC](#) [MCP73832T-2DCIMC](#) [MCP73833T-AMIMF](#) [MCP73833T-AMI/UN](#)
[MCP73838-NVI/MF](#) [MCP73213-A6BI/MF](#) [MCP73831-2ACI/MC](#) [MCP73831T-2ATIMC](#) [MCP73832-2ACI/MC](#) [MCP73832T-3ACIMC](#)
[MCP73833T-FCI/MF](#) [MCP73853-IML](#) [BQ25895RTWR](#) [BQ29704DSER](#) [BQ78Z100DRZR](#) [ISL78610ANZ](#) [FAN5403UCX](#)
[NCP367DPMUECTBG](#) [FAN54015BUCX](#) [MAX8934BETI+](#) [BQ24311DSGR](#) [BQ25100HYFPR](#) [BQ29707DSER](#) [MAX17048G+T10](#)
[BQ24130RHLLR](#) [BQ25120AYFPR](#) [BQ29703DSER](#) [BQ771807DPJR](#) [BQ25120AYFPT](#) [MAX17710GB+T](#) [MAX14634EWC+](#)
[BQ25121AYFPR](#) [BD99954GW-E2](#)