

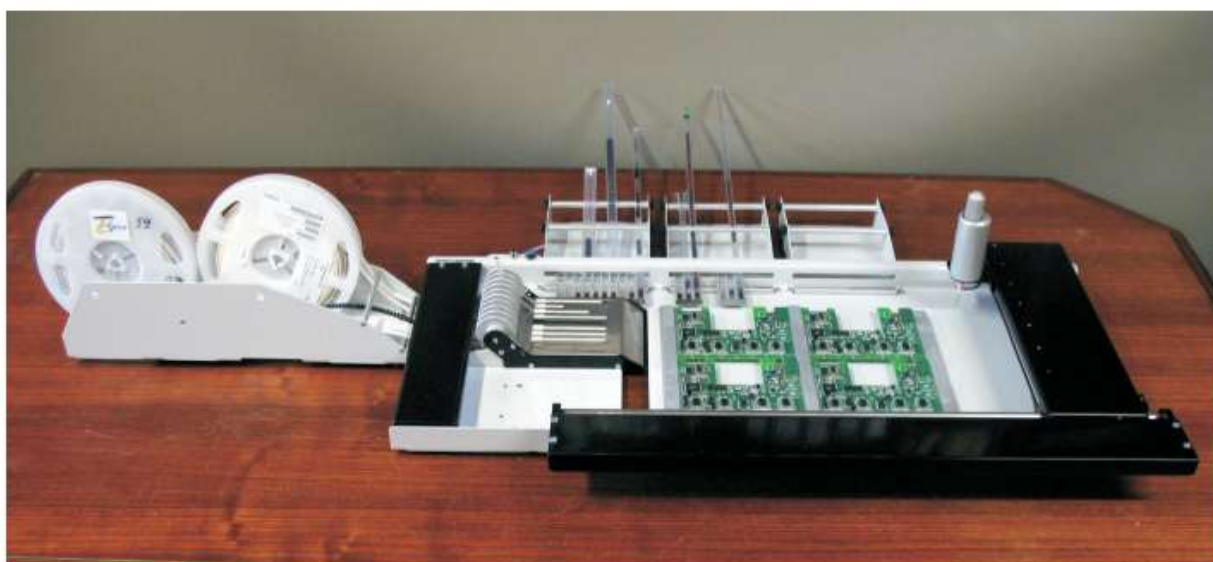

www.cif.fr

PICK & PLACE MANIPULATOR EASYPLACER & EASYPLACER.V (Ref V900120 & V900121)



Conformity Certificate EC



Us,

C.I.F

240 rue Hélène Boucher – 78530 BUC - France
Tel +33 (0)1 39 66 96 83 FAX +33 (0)1 39 66 97 78
email : cif@cif.fr – Site : www.cif.fr

(GB) We certify under our responsibility that the product:

Pick and place manipulator EASYPLACER & EASYPLACER.V Code : V900120 & V900121

conforms to European Economic Community standards :

- EN-60204-1
- EN 292

(F) Déclaration du constructeur

La société CIF– 78530 BUC, France, certifie que le produit répond bien aux directives de la Communauté Economique Européenne.

(GB) Manufacturer declaration :

CIF company CIF– 78530 BUC, France, herewith declare that this product conforms to E.E.C. regulations.

(E) Declaracion del constructor

La sociedad CIF– 78530 BUC, France, certifica que este producto satisface las directivas de la comunidad Europea.

(I) Dichiarazione del costruttore

La società CIF– 78530 BUC, France, attesta che il prodotto risponde alle direttive della Unione Europea.

(D) Herstellererklärung

Hiermit erklärt die Firma CIF–78530 BUC, France dass dieses produkt der Richtlinie EWG entspricht.

♦ In accordance with the following European Decrees :

- Low Voltage Directive 2006/42/EC
- Machinery Directive 2006/95/EC
- EMC Directive 2004/108/EC

Buc, November 2014

Authorised signature

Philippe ALBRIEUX

A handwritten signature in black ink, appearing to read 'Philippe Albrieux', is written over a horizontal line.

Contents:

PICK & PLACE MANIPULATOR	4
MAIN PARTS OF THE MANIPULATOR	5
TECHNICAL DATA	5
TAPE FEEDER	6
THE TAPE FEEDER POSITIONING ON AN ASSEMBLING DESK	6
TAPING OF THE FEEDERS	7
INTEGRATED CIRCUITS FEEDER	9
PLACEMENT OF THE PCB ON THE ASSEMBLING DESK	10
CONNECTORS	10
VACUUM PUMP, UNDERPRESSURE REGULATION	11
THE USAGE AND SETTINGS OF THE CAMERA	11
USAGE OF THE MANIPULATOR	12
MAINTENANCE OF THE MANIPULATOR	13

Pick & Place Manipulator

Pick & Place Manipulator (Manipulator) is a compact system intended for manual assembling of PCB prototypes or small series PCBs. Assembly head performs a smooth movement in both X and Y axis and therefore it allows the user to comfortably pick the components from the feeders and put them gently on a PCB. Precise movement of the header in Z axis direction allows very gentle placing of larger components (Integrated circuits, processors) into the tin paste, using the integrated vacuum switch. Rotation of components can be regulated by a button on a manipulator head. Effective lighting is also integrated in an assembling head.

EASYPLACER can also be ordered with a camera system upon request. Camera system makes assembly of small components like 0603, 0402 and QFP much easier. Picture from the camera can be shown on a LCD display. We supply high performance vacuum pump with a regulation valve that allows regulation of underpressure with EASYPLACER.

Standard package contains: Assembling desk with a movable shoulder support and an assembling head, 230V/12V adapter, vacuum pump, 3 pcs of printed circuits holder, 2 pcs of rubber sucking cups, 2 pcs of replaceable needles.

Additional order / optional accessories: Tape components feeders, reel holders, ICs feeders, Camera and LCD screen with accessories, spare rubber sucking cups and needles.

MAIN PARTS OF THE MANIPULATOR

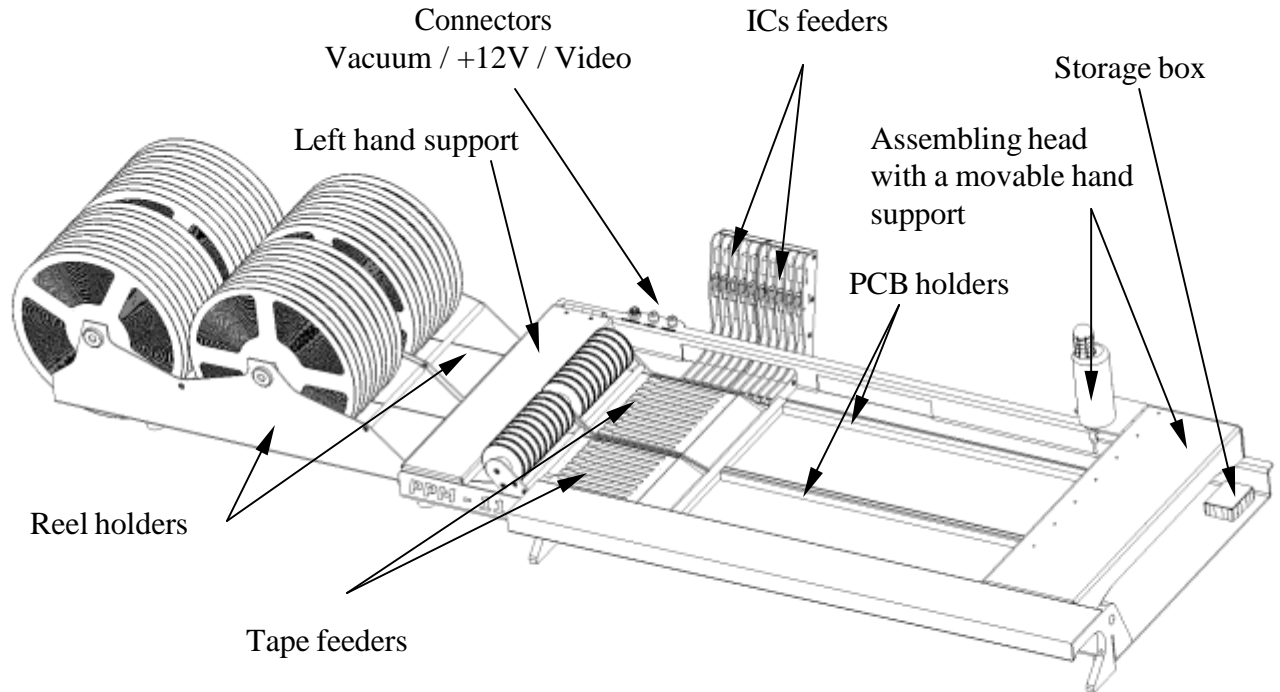

Technical data:

Manipulator dimensions:	765 x 390 x 210 (H) mm
Manipulator + feeders dimensions:	1145 x 430 x 210 mm
Motion of head in X/Y/Z axes:	470 x 240 x 15 mm
Weight:	6 kg
Desktop dimensions:	380 x 240 mm
Maximum PCB dimensions:	380 x 295 mm
Power supply:	230V/12 V
Vacuum pump supply power:	230V, 6W
Underpressure/flow:	>0,024 Mpa / 5dm ³ /min

Tape feeder

Multichannel tape feeder is a compact device which enables the removal of the covering foil from tapes and component picking. Furthermore it secures the position of tapes while picking the components and it ensures the removal of empty tapes. Flexible pinch plates allow stacking the tapes of various thicknesses. Tape feeder is easily removable from the assembling desk. When using more than two feeders it is possible to avoid unnecessary stacking or unstacking (which is a time consuming operation), particularly, it is advised that frequently repeated types of assembling had their respective feeders. Reel holders can be attached to the feeders, which is beneficial while feeding the tapes from the reels. It increases the comfort of assembling and ensures continuous feeding of the components tape. Once the work is finished it is possible to remove the reel holder along with the attached feeder at once, or to replace it with another, which ensures swift transition between individual tasks.

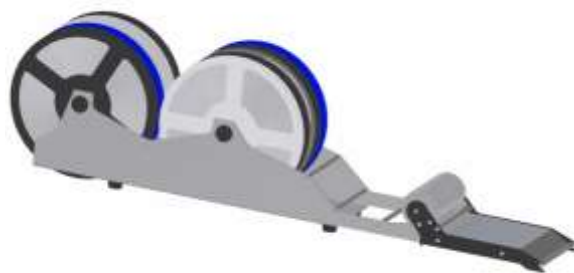

The tape feeder positioning on an assembling desk.

It is possible to put two tape feeders on an assembling desk at once



Tilt the left hand support. Grab the feeder from behind and lean it slightly forwards. Plug the feeder into the slot for feeders in such way that the jags on front part of the feeder got under the metal plate of the assembling desk. After the right plugging will the jags fit into the bottom rear sockets, which ensures that the feeder will not accidentally move when on the assembling desk. Take down the left hand support in the end.



TAPING OF THE FEEDERS

Important: always tap according to the standard (i.e. tapes should always be inserted from the left to the right, while the holes face the back of the feeder), otherwise the picking of the components will be difficult and the tape foil will twist while winding!

It is recommended to perform this task on the assembling desk as springing of the components from the tape cannot occur.

Before inserting the tape of the SMD components, tear the foil up to 5- 10 mm and slide it to the socket under the winding wheel. (The foil can as well be torn in the socket in front of the winding wheel using tools, such as tweezers.)



Shift the foil carefully forward until it shows in the socket in front of the winding wheel.

Take the foil and tear it up to the length of 5- 7 mm. (While tearing the foil, the tape moves forward in the channel- pay attention so that the components don't spring).

Drag the end of the foil under the stick in front of the winding wheels, then, using the 2- 3 cm long, 6-7 cm wide masking tape, glue the foil to the winding wheel so that it winds anti-clockwise. (If the foil is dragged over the stick, the tear can occur or the movement of the tape will be abrupt.)

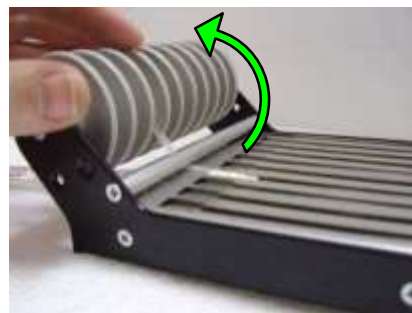

The SMD components tape is shifted forward by winding the foil to the winding wheel.

When using short cut tapes (these tapes are mostly wrinkled or damaged- broken), jamming, heavy shift of the tape forward or springing of the components can occur. Therefore it is recommended to straighten the tapes before winding.

The empty tape is dragged under the assembling desk, it does not disturb during the work and can be cut at any time.

REEL HOLDER FOR THE FEEDERS

A reel holder (RH), which enhances the comfort of assembling, can be attached to the tape feeder..

Slide the RH between the sideboards from the back, so that the axes of the holes with the thread on the RH and the axes of the countersunk holes on the feeders' sideboards lay on one and the same axis. Attach the RH to the feeders using the screws with the countersunk head. Then lay the set on the assembling table according to the already mentioned manner.

Reels can be added/replaced anytime during the assembling. The RH s are both frontal and rear. The direction of the shafts' removal represents the only difference.

Turn the excentric shaft so that the safety shim gets to the removable position and take out the shaft. Insert the reel to the guide hole of the RH. Respect the direction of the unwinding of the tape from the reel. Slide the shaft through the shaft socket and move through the reels; the shafts get to the smaller hole on the opposite side. If you have also moved the safety shim through the shaft socket, turn the shaft by 180°. By doing this, the reel will lift up and the shaft will be secured against the reelconnection or ejection. The tapes should be conducted under the guide sticks.

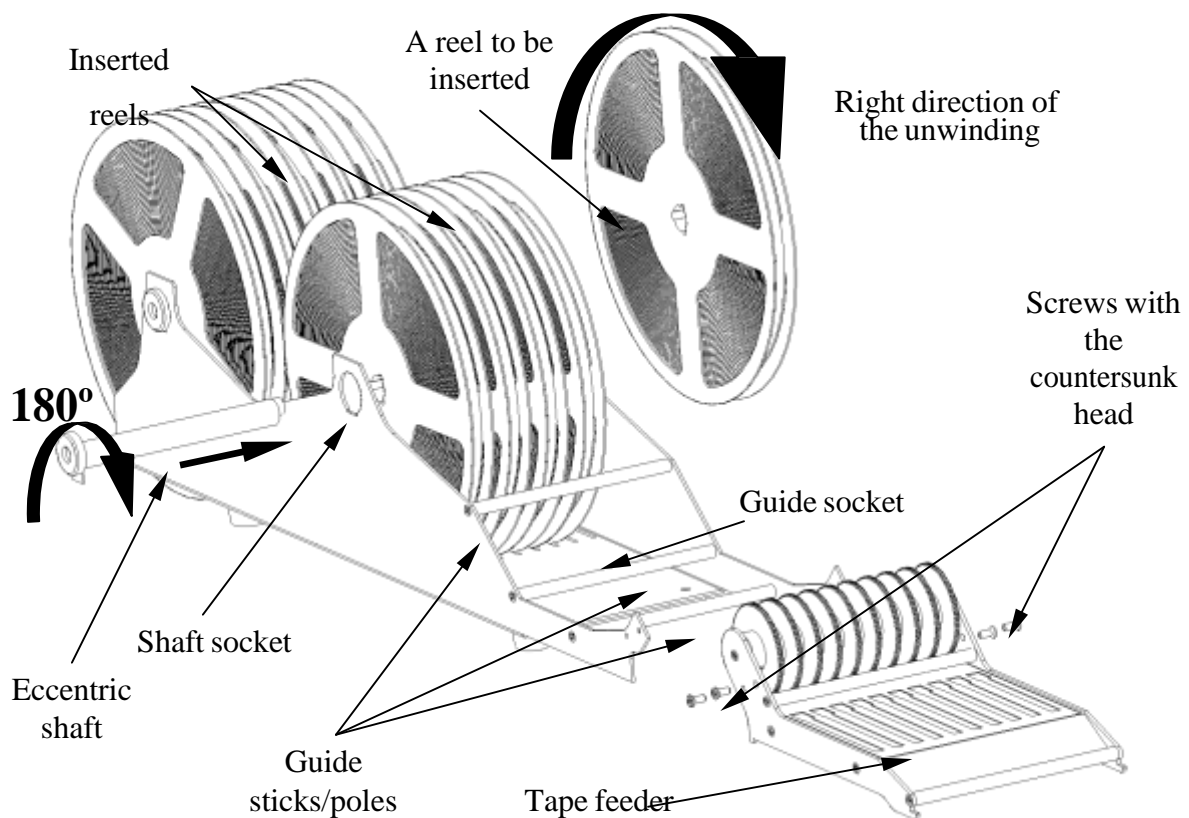

INTEGRATED CIRCUITS FEEDER

The integrated circuits feeder (ICF) allows feeding of the integrated circuits of various caskets..

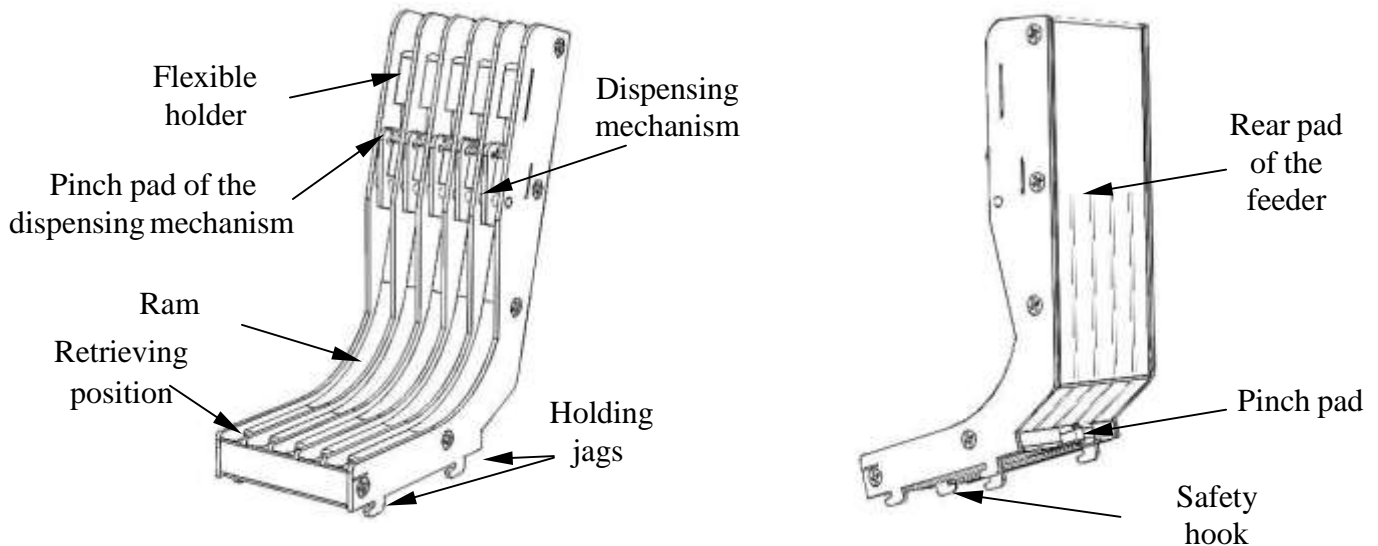

Sliding in the poles with integrated circuits (IC):) Remove the ICF from the assembling desk and put it rear down onto the table. Take out the safety catch from one end of the pole so that the IC does not spill. Slide this end under the flexible holder as far as it goes. Repeat the procedure for the required number of positions.



The holding jags and the safety hook are used for fastening of the ICF to the assembling desk. Press the safety hook as far as it goes. Insert the feeder (along with the poles) through the rear socket and slide the frontal and rear jags under the metal plate. Let go of the safety hook, it will fix the ICF. Make sure that the ICF is adequately fixed.

Feeding of the IC is a very simple task. Press the pinch pad of the dosing mechanism in the requested channel. One piece of the IC will slip from the dosing mechanism to the retrieving position, from where it can be easily picked up using a respective needle or a suction reel.

If any of the poles is emptied and you do not want to remove the whole feeder to replace the pole, you can carefully spill the ICs from the full pole to the empty one..

PLACEMENT OF THE PCB ON THE ASSEMBLING DESK

The PCB holders can be removed from the assembling desk (or replaced on the assembling desk) by pressing both ends together.

Press the ends according to the direction depicted (A). Place the PCB holder onto the assembling desk between the side holders and slide the jag placed on one end of the PCB holder to the canal on the side holder. Switch on the PCB holder and the jag will slip into the canal on the opposite side. Place the PCB to the upper canal. Set the pitch on the width of the PCB according to the upper canals. If the PCB dimension allows it, place several pieces at once onto the assembling desk. (The number can also depend on the number of components for one PCB or on the assembler's abilities.)

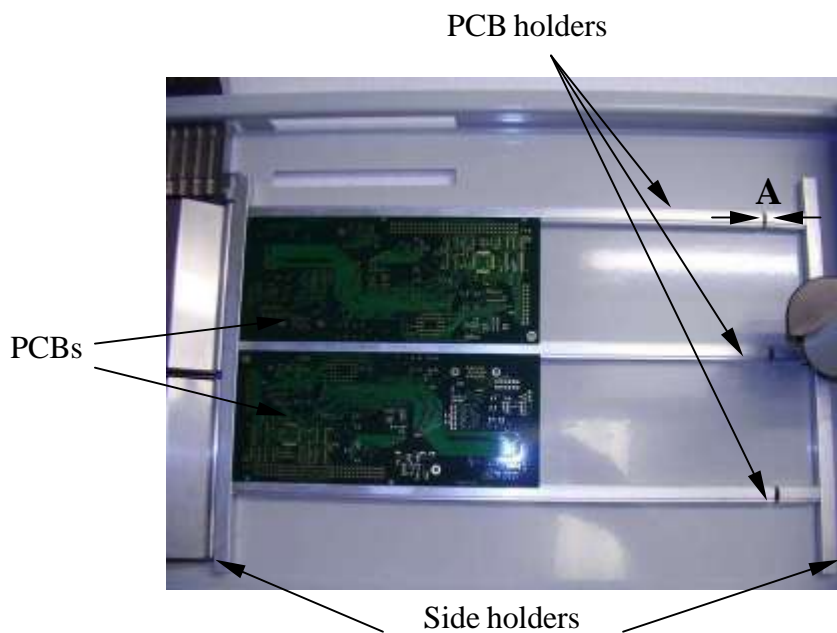

Connectors

According to the type, the manipulator can have 2 or 3 connection spots.

Vacuum: attach the regulation valve using the 4 mm Festo hosepipe. (Just push the hosepipe into the hole of the blue casket in order to secure it. If you want to detach it, slide the blue casket into the black one. It will free the hosepipe and you can easily pull it out.) Attach the vacuum pump to the opposite end of the regulation valve using the 4 mm Festo hosepipe.

+12V: attach the 230V/ 12V adapter. Make sure that the yellow switch at the bottom of the adapter points to 12 V.

VIDEO: (only if the recording system is installed within the manipulator) attach the video cable from the LCD display

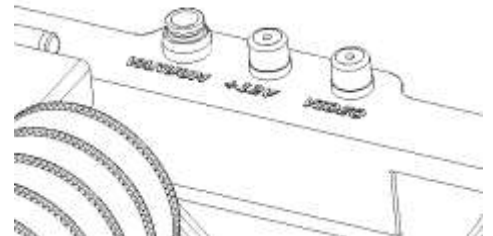

VACUUM PUMP, UNDERPRESSURE REGULATION

The vacuum pump produces the under pressure necessary for the process of assembling. Use exclusively the vacuum pump, which is included in the package, as it is designed specifically for the purpose stated above. The pump has two sucking openings. However, standardly only one of them is used- even just one of them having sufficient sucking power necessary for the assembling process.(You are free to use any one of them). The other opening can be used to double the under pressure or to secure the under pressure for another manipulator.

The under pressure can be regulated by the regulation valve. The maximum under pressure is needed for the removal of large or heavy components. In case of small components it is recommended to lower the intensity of the under pressure. The usage of sucking reels or the diameter of the needle immensely influences the under pressure necessary for lifting the components.



THE USAGE AND SETTINGS OF THE CAMERA (options)

EASYPLACER can be ordered along with the installed camera system which facilitates the assembling of small components with 0603, 0402 and QFP caskets. Customers thus receive manipulators with already installed and set cameras. Cameras can detune due to vibrations and jolts during transport, if that is the case, the reset is necessary. Customers themselves can perform all settings according to their needs. The display is attached to the video connector of the manipulator via the video cable (included in the package) and uses a separate adapter for the LCD display.

It is technically impossible to install the camera onto the vertical axis of the assembling needle, that's why it is installed under small angle. This can result in a slightly blurred image around the edges of the LCD display.

THERE ARE THREE OPTIONS WHEN SETTING THE CAMERA

1. **Turning around the X axis:** so that the X axis of the camera (the narrow horizontal line on the display) lies on the X axis of the needle. Turn the screws by half an evolve at the side part of the camera, set the concurrence of the X axes and fasten the security screws.
2. **Turn around the Y axis:** it is possible here to change the distance between the camera and the assembling desk. Turn the screws by half an evolve from the back part the camera; shift the camera to the required distance from the assembling desk. The chases on the camera holder and the security screws with pads allow partial turning of the camera around the Y axis, all of which enables the concurrence of the Y axis of the camera and the one of the assembling needle.

3. **Optics setting** : after the setting of the X and the Y axis, the camera image can be focused by twisting or turning the camera optics

The LCD display provides the usual settings (color, contrast, brightness), we can be set individually, according to one's need.

Usage of the manipulator

EASYPLACER Pick & Place Manipulator was developed for a manual assembling of SMD components.

Place the feeders according to above mentioned description on an assembling desk. Pick the needle with a suitable diameter for selected component and slid it carefully (not by a great force, so it can be easily removable) onto cone-shaped holder. If you are planning to lift the IC or a processor, it is recommended that you used a suction cup. It needs to be slid onto the assembling needle in such way that the tip of the assembling needle stayed inside of the suction cup.

Connect the vacuum pump, adapter (if you have the manipulator together with camera system, then connect the LCD display as well) to their respective plugs on an assembling desk and then connect to the power supply. Place the required quantity of pasted PCBs on PCB holders. Place the left hand on the left hand support, right hand on a movable support and grab the assembling head into your palm. You can rotate and push the button with your thumb and index finger. Mutual assembling needle rotates and moves up and down.

If you are planning to lift a whole component, simply move with the assembling head above the component, carefully shorten the distance between the component and the tip of the needle until the tip touches the component. This way will the tip of the needle suck in the component.

Assembling head has its own sensitive vacuum trigger, that allows moving up to 5-6mm. If you lift the component, the needle touches the component and you push the needle down for more than 5mm, the vacuum trigger will lower the under pressure and you would not be able to lift the component. In that case release the button completely vacuum trigger will get back to its original position and it will restore the under pressure set by the regulation valve.

There are two ways of placement of the component:

1. Small components will stick into the paste even without lowering the under pressure (if the under pressure is not too high and the paste half-dry).
2. Bigger (more than 8 outputs) and heavier components will only rarely stick into the paste, therefore lowering or disabling of the under pressure occurs

Vacuum switch can be used advantageously in laying the components, as some can be rather disturbing factor to achieve the necessary skills.

Maintenance of the manipulator

Manipulator does not require any special maintenance. But it is necessary to keep the round-shaped pole from the movable arm support clean, free from the dust. It is recommended it have it slightly oiled all the time. Wood or iron scobs can damage the linear bearings. After the work is finished it is vital that you cleaned the assembling needles from the tin paste remnants, because when they dry it is extremely hard to clean them. Drop 3-4 drops of oil into the button boring on an assembling head, 1-2 times a month and turn it on. Keep the feeders without the dust all the time and it is advised to clean slipping device before usage.

X-ON Electronics

Largest Supplier of Electrical and Electronic Components

Click to view similar products for [cif manufacturer](#):

Other Similar products are found below :

[AJB58](#) [V900130](#) [AL441](#) [DU68.10](#) [AAC20](#) [AD20](#) [V900131](#) [V900132](#) [AN10](#) [DU64.10](#) [V900121](#) [ABC16](#) [AAC16](#) [DU80](#) [DU67](#) [AEB16](#)
[AB15](#) [AR224](#) [DW101010](#) [AEB20](#) [AGP20](#) [AJP20](#) [AA20](#) [DU77](#) [AJP58](#) [DU71](#) [AGP30](#) [AA15](#) [ABB16](#) [DU66](#) [AGB30](#) [DU65.10](#) [ADB16](#)
[AR234](#) [AL435](#) [DU69](#) [AAT10](#) [DU85](#) [ADB20](#) [AE20](#) [AAB16](#) [AR45](#) [AB16](#) [AD16](#) [AJB22](#) [AJP22](#) [AGB10](#) [AR412](#) [AR21](#) [AJP16](#)