



# TM023023 Trackpad Specification

GlidePoint Circle Trackpad

Document Version 1.1

NOVEMBER 2017



This document describes Cirque's TM023023-XXX-XXX capacitive trackpad module (a 23-mm diameter, 3V, Pinnacle ASIC, SPI or I<sup>2</sup>C, 12 - pin connector). The "x's" in the part number are based on ordered configuration. Sample hardware and firmware are available upon request.

### Part Number:

- I<sup>2</sup>C: TM023023-2023-xxx
- SPI: TM023023-2024-xxx

## Document Version History

Date	Current Version	Description
AUGUST 2017	1.0	Initial document creation
NOVEMBER 2017	1.1	Added example part number for module with overlay

## Notice

**Note to Purchasers:** All specifications subject to change without notice. Cirque shall not be liable for any damages whether non-specified, direct, indirect, special, incidental or consequential (including downtime, loss of profit or goodwill) regardless of the legal theory asserted. This document is the sole property of Cirque Corporation. The information contained within is proprietary and may not be reproduced or disclosed to third parties without the prior written consent of Cirque Corporation.

## Copyright and Patent Information

Copyright© 2017 Cirque Corporation. All Rights Reserved. Cirque®, the Cirque logo, GlidePoint® the GlidePoint logo, and GlideExtend® are trademarks of Cirque Corporation. All other brand names or trademarks are the property of their respective owners.

Cirque's touch controller platforms and technology solutions are protected by patents and additional U.S. and International patents pending. Contact Cirque for more information.

# Table of Contents

---

<b>TM023023 Overview</b> .....	<b>4</b>
<b>General Specifications</b> .....	<b>5</b>
<b>Physical Dimensions</b> .....	<b>7</b>
<b>Interface Specifications</b> .....	<b>8</b>
Communication Specifications .....	9
Evaluating the Trackpad .....	11
<b>Additional Information</b> .....	<b>12</b>
Mounting Design Recommendations .....	12
ESD/EMI Protection Specification .....	12
Overlay Specifications .....	13
<b>TM023023 Testing</b> .....	<b>14</b>
ESD Test .....	14
Environmental Tests .....	14
<b>Contact Information</b> .....	<b>15</b>

# TM023023 Overview

The TM023023 is a unique circular trackpad that is perfect for specialized input applications such as game controllers and advanced consumer electronics. The TM023023 trackpad can be configured to use either I<sup>2</sup>C or SPI host interfaces.

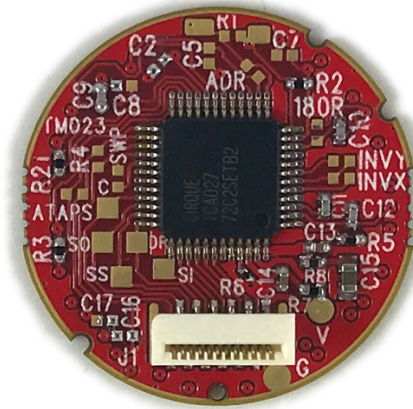

Figure 1. Example of the TM023023 Trackpad - Component View

This document describes the mechanical and electrical specifications for the TM023023 trackpad solution. It also describes how an external host controller can interface with the Cirque TM023023 solution using either the SPI or I<sup>2</sup>C protocol. Suggested design considerations are also covered.

## Benefits

Cirque's latest generation of trackpads define the standard for the pointing device industry. These solid-state devices are extremely durable because they have no moving parts to clog or break down. The trackpad's compact size, thin profile, and low weight, allow it to be easily designed into a variety of OEM products. These features, as well as the following benefits, make the TM023023 an ideal solution for integration.

- Built in precise positioning
- No contact pressure required
- No moving parts - high reliability - durable
- Compact size, thin profile, and lightweight
- Advanced features embedded in hardware
- Low stress / low fatigue operation
- Environmentally sealable design
- Power saving operation modes
- Adaptable and collaborative support is offered for integration
- Built on Cirque's vast experience of providing innovative technology

Cirque GlidePoint<sup>®</sup> trackpads are based upon patented mutual capacitance technology, which provides smooth and precise cursor control. A sophisticated sensing array is below the trackpad's durable surface, which accurately responds to even the smallest finger movements. No finger pressure is required. Simply move a finger across the trackpad to move the cursor.

# General Specifications

---

## Operational Specifications

<b>Motion Detection Method:</b>	Mutual capacitance sensing.
<b>X/Y Position Sensing Resolution:</b> (See <a href="#">Position Reporting on page 10</a> for more information.)	<b>Max:</b> $0 \leq X \leq 2048$ and $0 \leq Y \leq 1536$ <b>Active:</b> $128 \leq X \leq 1920$ and $64 \leq Y \leq 1472$
<b>X/Y Position Reporting:</b> (See <a href="#">Communication Specifications on page 9</a> for more information.)	Both absolute and relative modes are available. <b>Note</b> <i>Position reporting mode is set when the user enables the trackpad.</i>
<b>Touch Force:</b>	No contact pressure required.
<b>Lifetime:</b> (Plastic overlay)	Minimum 10,000,000 strokes (500 km)

## Electrical Specifications

<b>Power Supply Voltage:</b>	2.5 - 3.6 V
<b>Power Consumption:</b> (Typical values)	SPI or I <sup>2</sup> C <i>Module was tested at 3.3 V</i>
<b>Active Mode:</b> (Finger moving on pad)	2.9 mA
<b>Idle Mode:</b> (No finger on pad)	1.7 mA
<b>*Sleep Mode:</b> (No finger on pad after ~5 sec.) <i>Not active by default, but can be enabled in the configuration register.</i>	40 $\mu$ A
<b>**Shutdown Mode</b> <i>Not active by default, but can be enabled in the configuration register.</i>	0.23 $\mu$ A

\* The value shown is for a touch-sensing interval of 3 seconds.  
Other scan intervals can be configured. Contact Cirque if planning to use this mode.

\*\* In shutdown mode, touch input is disabled. Contact Cirque if planning to use this mode.

## Environmental Specifications

<b>Operating Temperature:</b>	-40° to +85° Celsius (as measured at component side)
<b>Operating Humidity:</b>	Up to 95% relative humidity (Non-condensing)*
<b>Storage Temperature:</b>	-40° to +125° Celsius
<b>Storage Humidity:</b>	5 to 95% relative humidity (Non-condensing)*
<b>ESD:</b> (Applied to sensing surface)	$\pm 15$ kV when module is properly installed

\* Only for Humidity Test. Humidity is not controlled for other tests.

**Note:** For more information, see the [CT-120305 Environmental Test](#) document.

## Interface Specifications

---

<b>Communication Protocols:</b>	Inter-Integrated Circuit (I <sup>2</sup> C) or Serial Peripheral Interface (SPI)
---------------------------------	---

---

**Note:** Cirque offers the following to assist with integrating the TM023023 into your product:

- [GT-AN-090620 Interfacing to Pinnacle I<sup>2</sup>C and SPI application note](#), contact your Cirque representative.
- [Arduino compatible sample code](#); this code supports evaluating the trackpad (see [page 11](#)).

## Physical Specifications

---

<b>Module Thickness:</b>	0.74 mm PCB ( $\pm 0.070$ ) 0.89 mm PCB + Adhesive ( $\pm 0.120$ ) 5.04 mm PCB + Adhesive + Components ( $\pm 0.320$ )
<b>Module Diameter:</b>	23.20 mm ( $\pm 0.25$ )
<b>Sensing Area Diameter:</b>	21.60 mm

---

**Note:** See [Physical Dimensions on page 7](#) for detailed dimensions.

# Physical Dimensions

This section provides the dimensions of the TM023023 (See [Figure 2](#) below).

**Note:** Unless otherwise noted:

- All dimensions shown in mechanical drawings are in millimeters. Drawings are not to scale.
- Tolerances as indicated in drawing.

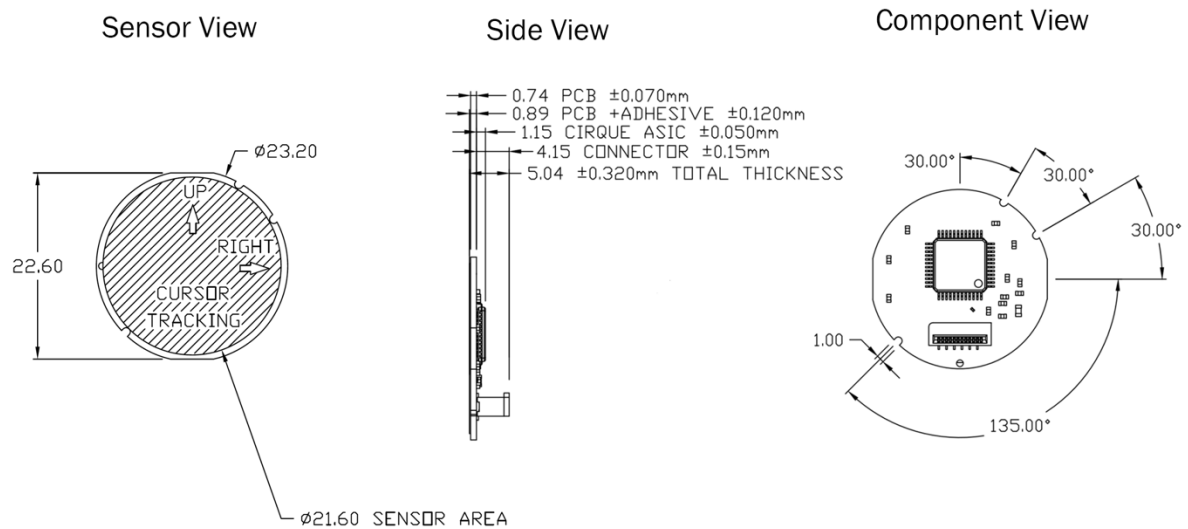

Figure 2. TM023023 Design Dimensions - Sensor Dimensions, Side, Component, and Side Views

**Note:** The trackpad will need to be aligned using the alignment notches when importing into your designs (see [Alignment on page 12](#)).

The “up” indicator on the above diagram is accurate when the trackpad is operating in relative tracking mode. In absolute tracking mode the “up” direction arrow should be inverted.

# Interface Specifications

This section describes how the module connects or communicates to the host.

## Block Diagram

TM023023-202X-XXX Module

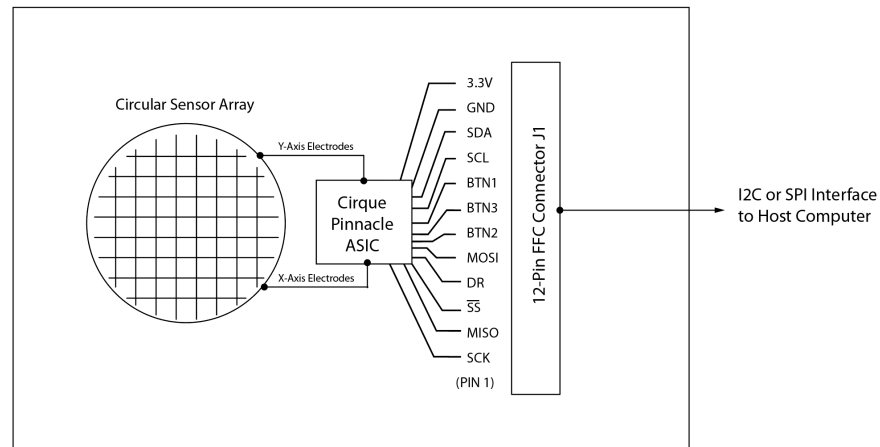

Figure 3. TM023023-202X-XXX Block Diagram

## Connection to Host Computer

The 12-pin connector mounted on the trackpad module supports signals for SPI or I<sup>2</sup>C communication, and power supply (see [Table 1](#)).

Table 1. Pin Order of the J1 Connector for SPI

1	2	3	4	5	6	7	8	9	10	11	12
SCK	MISO	SS	DR	MOSI	BTN2	BTN3	BTN1	SCL	SDA	GND	VDD 3.3 V

**Note:** The number one pin is on the left side of the connector (see [Figure 4](#)). Connector pins engage FFC (flat flex cable) on pin1 side. Install FFC with visible conductors on pin 1 side.

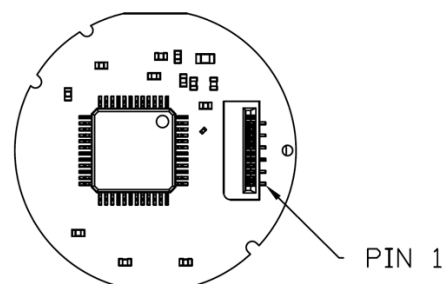

Figure 4. TM023023 - Pin #1 Placement Example



Table 2. J1 Connector Manufacturing Sources

Manufacturer	Description	Part Number
Molex <a href="http://www.molex.com">http://www.molex.com</a>	12 circuit, 0.50mm pitch FFC/FPC connector, surface mount, vertical, non-ZIF, reverse footprint, gold plating	Part#: 78127-1128

## Communication Specifications

TM023023 can be ordered as either a SPI or I<sup>2</sup>C device. Cirque offers an interfacing document for using this trackpad with I<sup>2</sup>C and SPI. Contact your Cirque sales representative for the [GT-AN-090620 Interfacing to Pinnacle I<sup>2</sup>C and SPI](#) application note.

**Note:** Cirque offers an evaluation kit based on an Arduino-compatible “Teensy 3.2” processor. Sample code is available for evaluating the TM023023 with this evaluation kit (see [page 11](#)).

## Configuring the TM023023 for SPI or I<sup>2</sup>C Operation

Populate the R1 location with a 470 kΩ resistor to configure the device for SPI operation. Leave R1 unpopulated for I<sup>2</sup>C operation. No other changes are required to set communication modes on the TM023023.

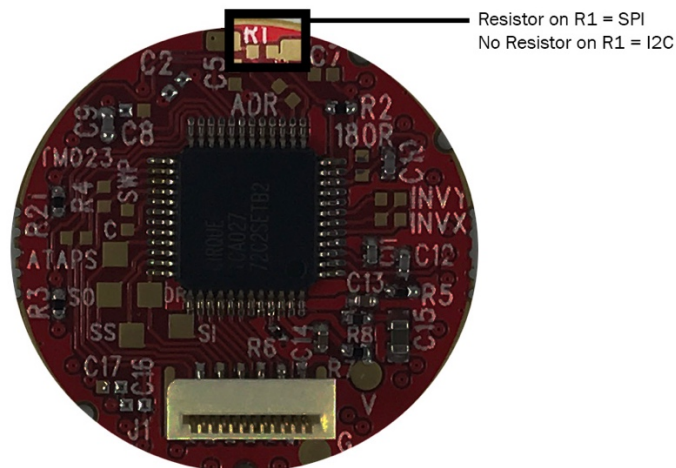

Figure 5. Example Difference Between a SPI or I<sup>2</sup>C Trackpad

## Position Reporting

X/Y positions can be reported in a relative or absolute manner. Position reporting mode is set by the host at device power on. The [GT-AN-090620 Interfacing to Pinnacle I<sup>2</sup>C and SPI](#) application note provides the details on how to make this change. In relative mode, the touch data is always a DELTA or change with respect to the previous position. Deltas are expressed in Two's complement notation. Positions can also be reported in an absolute mode, where the touch data is always the absolute finger position on the pad.

## Maximum Range

The Pinnacle ASIC is designed to report absolute position values ranging  $0 \leq X \leq 2048$  and  $0 \leq Y \leq 1536$ . Due to the distinct properties of the outermost electrodes, the active area (or reachable area) of the sensor is slightly reduced. See [Figure 6](#) below for a description of active range coordinates.

**Note:** There are instances where electrical noise may cause reported coordinates that are just outside the Active range shown in [Figure 6](#). As a precaution, Cirque recommends that the designer implement “clipping” on the reported coordinates to  $128 \leq X \leq 1920$  and  $64 \leq Y \leq 1472$ . This clipping ensures that any scaling/mapping algorithm employed by the system will have predictable behavior near the operational limits.

Contact a Cirque representative for further details (see, [Contact Information on page 15](#)).

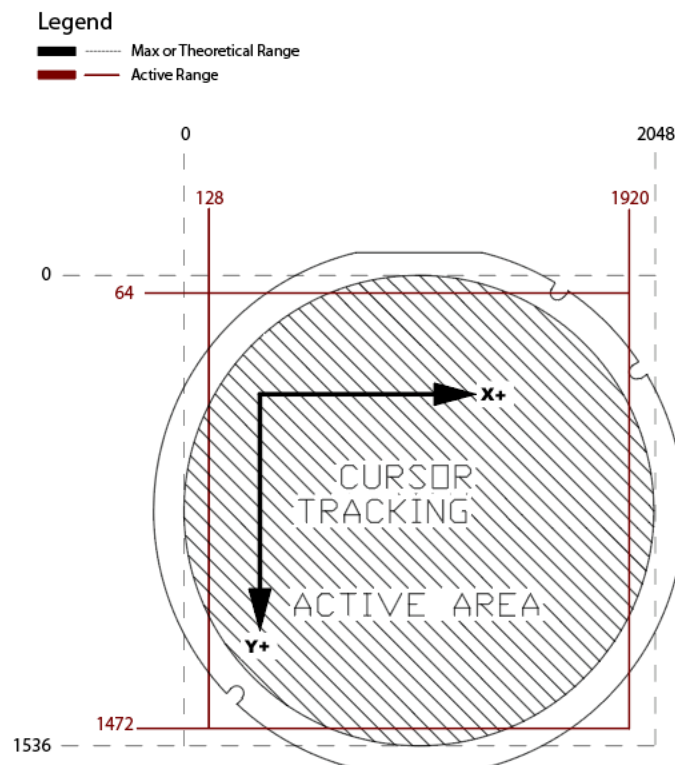

Figure 6. Representation of the Difference Between Maximum and Active Range (drawing not to scale).

**Note:** In absolute mode, the Y-Axis is inverted. It can be flipped by modifying Bit 7 in the FeedConfig1 register.

## Evaluating the Trackpad

Cirque has created a demo project using the simple-to-use Arduino environment and a low-cost Teensy 3.2 development board. This configuration makes evaluating the TM023023 trackpad a plug-and-play experience.

The powerful ARM processor onboard Teensy 3.2, combined with the simple Arduino environment, greatly simplifies the development of algorithms and proof-of-concept designs.

**Note:** *By default, Arduino does not have built-in support for Teensy hardware. Teensyduino (a software add-on) will need to be installed in conjunction with the Arduino IDE.*

For more information about how to obtain these products, see Cirque's [GlidePoint Circle Trackpads web page](#).

# Additional Information

---

## Mounting Design Recommendations

The thin, flat profile of the TM023023 makes it compatible with a variety of industry practices for mounting trackpads into enclosures. It is important to support the trackpad from the underside of the trackpad assembly. This support prevents excessive flexing of the assembly during finger tapping operations. Avoid using conductive materials in the bezel.

### Alignment

The gaming trackpad incorporates three notches in the outer perimeter that are used to align the TM023023 correctly within the product (see [Figure 2 on page 7](#)).

### Mounting Techniques

**Clamshell Mounting:** A common practice for mounting trackpads into enclosures involves clamping the assembly between two of the enclosure's components, resulting in a clamshell structure that secures the trackpad in place. The upper section of the clamshell typically includes the bezel window opening and alignment features, while the bottom section of the clamshell incorporates support features. It is recommended that a slight amount of interference exist between the clamshell structure and the trackpad to prevent it from sliding or rattling around within the bezel window.

## ESD/EMI Protection Specification

Cirque performs ESD tests at the module level. OEM customers should test and validate ESD performance at each system level. Cirque's ESD tests are based on the IEC 61000-4-2, a system-level test specification.

### EMI Susceptibility

The TM023023 exhibits low susceptibility to electromagnetic interference in noisy environments. Contact a Cirque OEM sales representative to obtain EMI guidelines and test procedures.

## Overlay Specifications

The TM023023 trackpad has an overlay available which is a flat black, 23.20 mm (diameter), laminate overlay.

OEM customers may order a trackpad without an overlay and then purchase their own customized overlay. Custom overlays may include a logo and matching colors. Trackpad functionality is impeded by overlays that use conductive materials (gold, silver, carbon, and so forth); these materials should not be used.

**Note:** *Ensure no air gaps remain when adhering an overlay to a trackpad. For reliable performance, air gaps between the trackpad sensing surface and the overlaying surface must be eliminated.*

# TM023023 Testing

To ensure that the TM023023 meets the highest quality demands, Cirque performs the tests listed below. Cirque's development tests are several tests that are conducted on a predefined sample. These tests validate the module for the specified environmental and ESD conditions.

## ESD Test

Cirque's modules are tested to insure their sustained and consistent operation if subjected to realistic levels of Electrostatic Discharge (ESD). Two types of ESD tests are conducted, Air Discharge and Horizontal Plane (Direct Contact). These tests are based on the IEC 61000-4-2 standard, which is a systems-level test spec. Cirque performs ESD tests at the module level. OEM customers should test and validate ESD performance at each system level.

## Environmental Tests

The Environmental tests are performed to verify that a module can withstand harsh environments; for example, extremely low and high temperatures, high humidity, and large and rapid changes in temperature. Each Environmental test is performed by placing the modules in a test chamber. For more information, see the [CT-120305 Environmental Test](#) document. Cirque performs the following tests at the identified condition:

Table 3. Tests and Conditions

Tests	Conditions
Operational Temperature	Measure compensation matrix change from -40 °C to 85 °C.
High Temperature Storage	Store at 85 °C for 96 hours. After soaking, verify operation. Verify compensation matrix values have not excessively changed from starting values.
Low Temperature Storage	Store at -40 °C for 96 Hours. After soaking, verify operation. Verify compensation matrix values have not excessively changed from starting values.
Temperature Cycle	Cycle temperatures between -40 °C and 85 °C for 2 hours each cycle. After cycling, verify operation. Verify compensation matrix values have not excessively changed from starting values. Perform test 10 times.
Humidity Soak	Store at 40 °C and 93% humidity for 96 Hours. After soaking, verify operation. Verify compensation matrix values have not excessively changed from starting values.

## Contact Information

---

Contact a Cirque sales representative for a complete list of Cirque's OEM products.

**In United States & Canada:** (800) GLIDE-75 (454-3375)

**Outside US & Canada:** (801) 467-1100

**Fax:** (801) 467-0208

**Web site:** <http://www.cirque.com>

## Part Ordering Information

When ordering parts, please contact your Cirque representative to assist you in selecting the correct size, power, configurations, and overlay that will best meet your needs. The “x’s” in the part number are based on custom configuration.

I<sup>2</sup>C Example (No Overlay): TM023023-2023-000

I<sup>2</sup>C Example (Flat Overlay): TM023023-2023-002

*Table 4. I<sup>2</sup>C Part Number Explanation*

Category	Model#	Volt	IC	I/O	Custom Configuration	Custom Configuration	Overlay Type
TM	023023	2 = 3 V	02 = Pinnacle	3 = I <sup>2</sup> C	0	0	X

SPI Example (No Overlay): TM023023-2024-000

SPI Example (Flat Overlay): TM023023-2024-002

*Table 5. SPI Part Number Explanation*

Category	Model#	Volt	IC	I/O	Custom Configuration	Custom Configuration	Overlay Type
TM	023023	2 = 3 V	02 = Pinnacle	4 = SPI	0	0	X

THIS INFORMATION IS PROVIDED “AS IS.” CIRQUE SPECIFICALLY DISCLAIMS ALL WARRANTIES EXPRESSED OR IMPLIED, INCLUDING BUT NOT LIMITED TO, IMPLIED WARRANTIES OF MERCHANTABILITY AND FITNESS FOR A PARTICULAR PURPOSE WITH RESPECT TO THE DOCUMENTATION AND USE OF THE DOCUMENTATION IN DESIGN OF ANY PRODUCTS OR FOR ANY PARTICULAR APPLICATION.

## **X-ON Electronics**

Largest Supplier of Electrical and Electronic Components

*Click to view similar products for [Capacitance Touch Sensor Modules](#) category:*

*Click to view products by [Cirque](#) manufacturer:*

Other Similar products are found below :

[96LEDK-A215FH25NF5](#) [TM040040-2024-302](#) [TM023023-2024-002](#) [TM040040-2024-301](#) [EXII-7720SC](#) [EXII-7760UC](#) [837](#) [ETM-RES05C-EEH4EE](#) [TPR40-P101](#) [W7ED-11F](#) [W7ED-12F](#) [W7ED-11L](#) [W7ED-12L](#) [TPR48-P201-S](#) [TPS48-P201-S](#) [TPE48-P201-S](#)  
[TM035035-2024-000](#) [TM035035-2024-003](#) [TM040040-2024-300](#) [TM023023-2024-000](#) [TM035035-2024-001](#)