

## Multi-Bit A/D for Class-D Real-Time PSR Feedback

### Features

- Advanced Multi-bit Delta-Sigma Architecture
- Real-time Feedback of Power Supply Conditions (AC and DC)
- Filterless Digital Output Resulting in Very Low Signal Delay
- 135 mW Power Consumption
- Supports Logic Levels Between 3.3 V and 5.0 V
- Differential Analog Architecture
- Modulator Overflow Detection
- Interfaces Directly to the CS44800/CS44600 Class-D PWM Modulator
- Multi-bit Conversion at up to 7.5 MHz
- Delivers Modulated Data Over 2-Wire Interface

### General Description

The CS4461 is a complete analog-to-digital converter for class-D real-time power supply rejection (PSR) feedback. It performs sampling and analog-to-digital conversion, generating digital data for input to a class-D modulator with real-time PSR feedback capabilities.

The CS4461 uses a 5th-order, multi-bit delta-sigma modulator followed by output data formatting. The ADC uses a differential architecture which provides excellent noise rejection.

The CS4461 feeds back the AC and DC voltage components and is ideal for class-D audio systems requiring high power supply rejection.

The CS4461 is available in a 24-pin TSSOP package in both Commercial (-10° to +70° C) and Automotive grade (-40° to +85° C). The CDB44800 Customer Demonstration board is also available for device evaluation and implementation suggestions. Please see ["Ordering Information"](#) on page 11 for complete details.

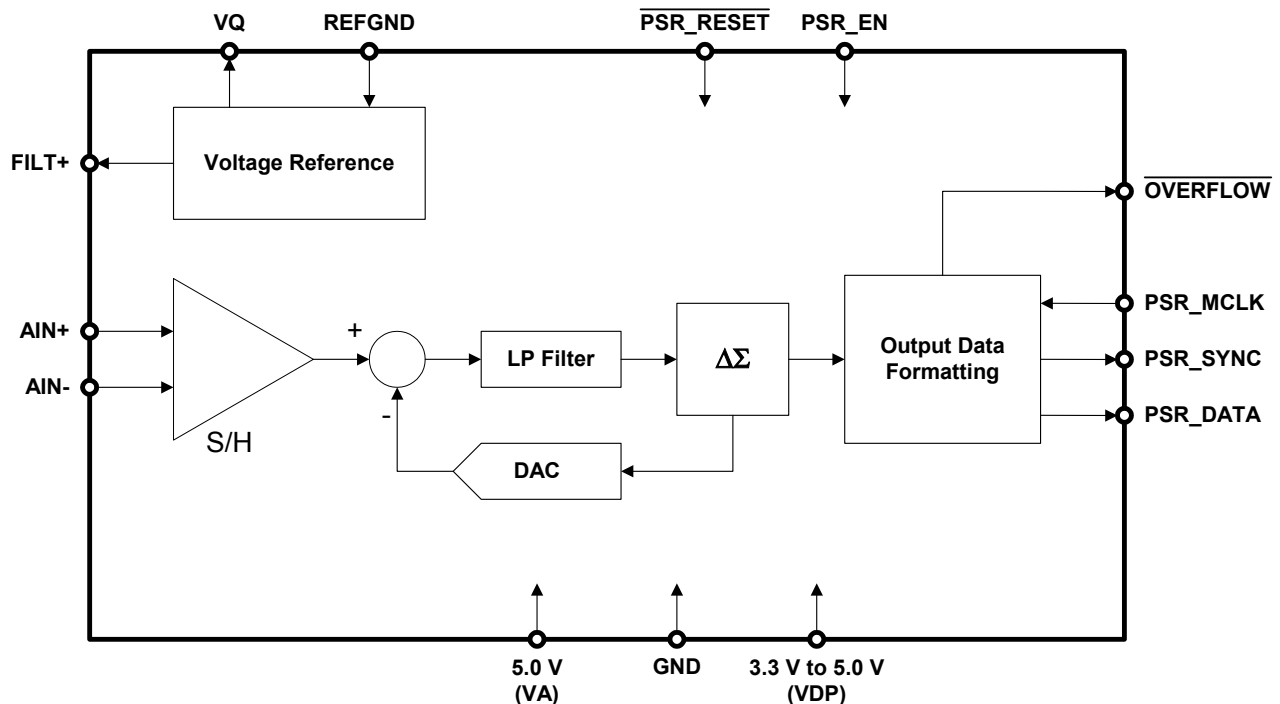

---

**TABLE OF CONTENTS**

<b>1. CHARACTERISTICS AND SPECIFICATIONS</b> .....	<b>3</b>
<b>2. PIN DESCRIPTIONS</b> .....	<b>6</b>
<b>3. TYPICAL CONNECTION DIAGRAM</b> .....	<b>7</b>
<b>4. APPLICATIONS</b> .....	<b>8</b>
4.1 Digital Connections .....	8
4.2 Analog Connections .....	8
4.3 Power-Up Sequence .....	9
4.4 Overflow Detection .....	9
4.5 Grounding and Power Supply Decoupling .....	9
<b>5. PACKAGE DIMENSIONS</b> .....	<b>10</b>
<b>6. ORDERING INFORMATION</b> .....	<b>11</b>
<b>7. REVISION HISTORY</b> .....	<b>11</b>

**LIST OF FIGURES**

Figure 1. Typical Connection Diagram.....	7
Figure 2. CS4461 Recommended Analog Input Buffer.....	8

## 1. CHARACTERISTICS AND SPECIFICATIONS

(All Min/Max characteristics and specifications are guaranteed over the Specified Operating Conditions. Typical performance characteristics and specifications are derived from measurements taken at typical supply voltages and  $T_A = 25^\circ\text{C}$ .)

### SPECIFIED OPERATING CONDITIONS

(GND = 0 V, all voltages with respect to 0 V.)

Parameter		Symbol	Min	Typ	Max	Unit
DC Power Supplies:	Positive Analog	VA	4.75	5.0	5.25	V
	Positive Digital	VDP	3.1	3.3	5.25	V
Ambient Operating Temperature	Commercial (-CZZ)	$T_{AC}$	-10	-	+70	$^\circ\text{C}$
	Automotive (-DZZ)	$T_{AA}$	-40	-	+85	$^\circ\text{C}$

### ABSOLUTE MAXIMUM RATINGS

(GND = 0 V, All voltages with respect to ground.) (Note 1)

Parameter		Symbol	Min	Max	Units
DC Power Supplies:	Analog	VA	-0.3	+6.0	V
	Digital	VDP	-0.3	+6.0	V
Input Current	(Note 2)	$I_{in}$	-	$\pm 10$	mA
Analog Input Voltage	(Note 3)	$V_{IN}$	GND - 0.7	VA + 0.7	V
Digital Input Voltage	(Note 3)	$V_{IND}$	-0.7	VDP + 0.7	V
Ambient Operating Temperature (Power Applied)		$T_A$	-50	+95	$^\circ\text{C}$
Storage Temperature		$T_{stg}$	-65	+150	$^\circ\text{C}$

#### Notes:

1. Operation beyond these limits may result in permanent damage to the device. Normal operation is not guaranteed at these extremes.
2. Any pin except supplies. Transient currents of up to  $\pm 100$  mA on the analog input pins will not cause SCR latch-up.
3. The maximum over/under voltage is limited by the input current.

## DC ELECTRICAL CHARACTERISTICS

(GND = 0 V, all voltages with respect to ground.

PSR\_MCLK=12.288 MHz)

Parameter	Symbol	Min	Typ	Max	Unit
Power Supply Current (Normal Operation)	VA	-	17.5	21	mA
	VDP = 5.0 V	-	22	26	mA
	VDP = 3.3 V	-	14.5	17	mA
Power Supply Current (Power-Down Mode) (Note 4)	VA	-	2	-	mA
	VDP = 5.0 V	-	2	-	mA
Power Consumption (Normal Operation)		-	198	235	mW
	VDP = 5.0 V	-	135	161	mW
	VDP = 3.3 V	-	20	-	mW
	VDP = 5.0 V	-	20	-	mW
ADC Power Supply Rejection Ratio (1 kHz) (Note 5)	PSRR	-	65	-	dB
V <sub>Q</sub> Nominal Voltage		-	2.5	-	V
Output Impedance		-	25	-	kΩ
Maximum allowable DC current source/sink		-	0.01	-	mA
FILT+ Nominal Voltage		-	5	-	V
Output Impedance		-	18	-	kΩ
Maximum allowable DC current source/sink		-	0.01	-	mA

### Notes:

- Power Down Mode is defined as  $\overline{\text{PSR\_RESET}} = \text{Low}$  with all clocks and data lines held static.
- Valid with the recommended capacitor values on FILT+ and VQ as shown in the Typical Connection Diagram.

## DIGITAL CHARACTERISTICS

Parameter	Symbol	Min	Typ	Max	Units
High-Level Input Voltage (% of VDP)	V <sub>IH</sub>	70%	-	-	V
Low-Level Input Voltage (% of VDP)	V <sub>IL</sub>	-	-	30%	V
High-Level Output Voltage at I <sub>o</sub> = 100 μA (% of VDP)	V <sub>OH</sub>	70%	-	-	V
Low-Level Output Voltage at I <sub>o</sub> = 100 μA (% of VDP)	V <sub>OL</sub>	-	-	15%	V
$\overline{\text{OVERFLOW}}$ Current Sink	I <sub>OVERFLOW</sub>	-	-	4.0	mA
Input Leakage Current	I <sub>in</sub>	-	-	±10	μA

## THERMAL CHARACTERISTICS

Parameter	Symbol	Min	Typ	Max	Unit
Allowable Junction Temperature		-	-	135	°C
Junction to Ambient Thermal Impedance	θ <sub>JA</sub>	-	70	-	°C/W

## ANALOG CHARACTERISTICS

(Test conditions (unless otherwise specified): Input test signal is a 1 kHz sine wave; measurement bandwidth is 10 Hz to 20 kHz.)

Parameter	Symbol	Min	Typ	Max	Unit
<b>DC Accuracy</b>					
Gain Error			-	±5	%
Gain Drift		-	±100	-	ppm/°C
<b>Analog Input Characteristics</b>					
Full-scale Differential Input Voltage	-CZZ	-	1.13*VA	-	V <sub>PP</sub>
	-DZZ	-	1.13*VA	-	V <sub>PP</sub>
AIN+/AIN- Input Range (VA = 5.0 V)	-CZZ	1.1	-	3.9	V
	-DZZ	1.1	-	3.9	V
Input Impedance (Differential)	(Note 6)	18	-	-	kΩ
Common Mode Rejection Ratio	CMRR	-	82	-	dB

### Notes:

6. Measured between AIN+ and AIN-

## 2. PIN DESCRIPTIONS

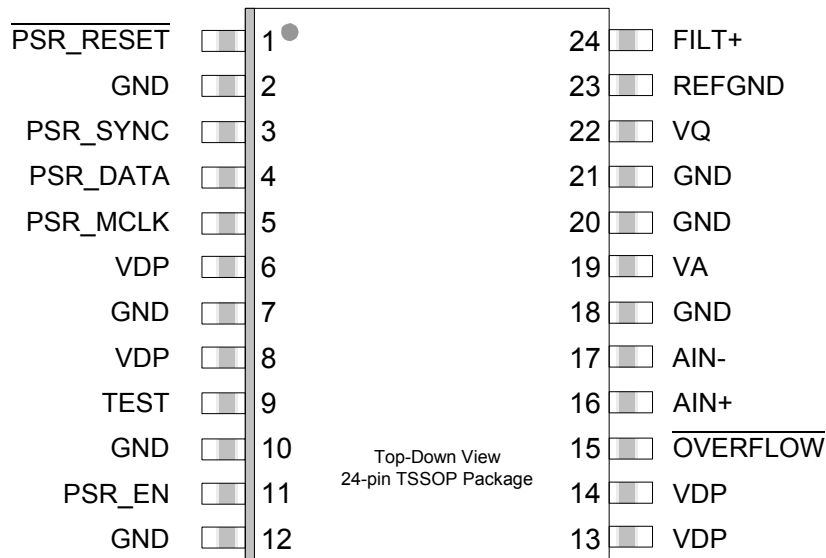

Pin Name	#	Pin Description
VDP	6 8 13 14	<b>Digital Logic Power (Input)</b> – Digital core and input/output power supply. Nominally +3.3 V or +5.0 V. Supply decoupling should be placed as close as possible to pin 6.
VA	19	<b>Analog Power (Input)</b> - Analog power supply. Nominally +5.0 V.
GND	2 7 10 12 18 20 21	<b>Ground (Input)</b> - Ground reference for both analog and digital.
PSR_RESET	1	<b>Reset (Input)</b> - When $\overline{\text{PSR\_RESET}}$ is low, the CS4461 enters a low power mode and all internal states are reset. On initial power up, $\overline{\text{PSR\_RESET}}$ must be held low until the power supply is stable, and all input clocks are stable in frequency and phase.
VQ	22	<b>Quiescent Voltage (Output)</b> - Filter connection for the internal quiescent reference voltage.
REFGND	23	<b>Reference Ground (Input)</b> - Ground reference for the internal sampling circuits.
FILT+	24	<b>Positive Voltage Reference (Output)</b> - Positive reference voltage for the internal sampling circuit.
AIN+ AIN-	16 17	<b>Differential PSR Analog Input (Input)</b> - Signals are presented differentially to the delta-sigma modulator via the AIN+/- pins.
PSR_MCLK	5	<b>Master Clock (Input)</b> - Clock source for the delta-sigma modulator and output data.
PSR_SYNC	3	<b>Synchronization Data Output (Output)</b> - Used to synchronize the serial data in the PWM modulator.
PSR_DATA	4	<b>PSR Serial Data Output (Output)</b> - Power supply modulated and formatted serial data.
PSR_EN	11	<b>PSR Enable (Input)</b> - A high to low transition on this pin will enable the PSR feedback circuit.
OVERFLOW	15	<b>Overflow (Output, open drain)</b> - Indicates a modulator overflow condition.
TEST	9	<b>Test (Output)</b> - This pin may toggle during normal operation and should be pulled low through a 47 k $\Omega$ resistor to GND in order to minimize noise.

### 3. TYPICAL CONNECTION DIAGRAM

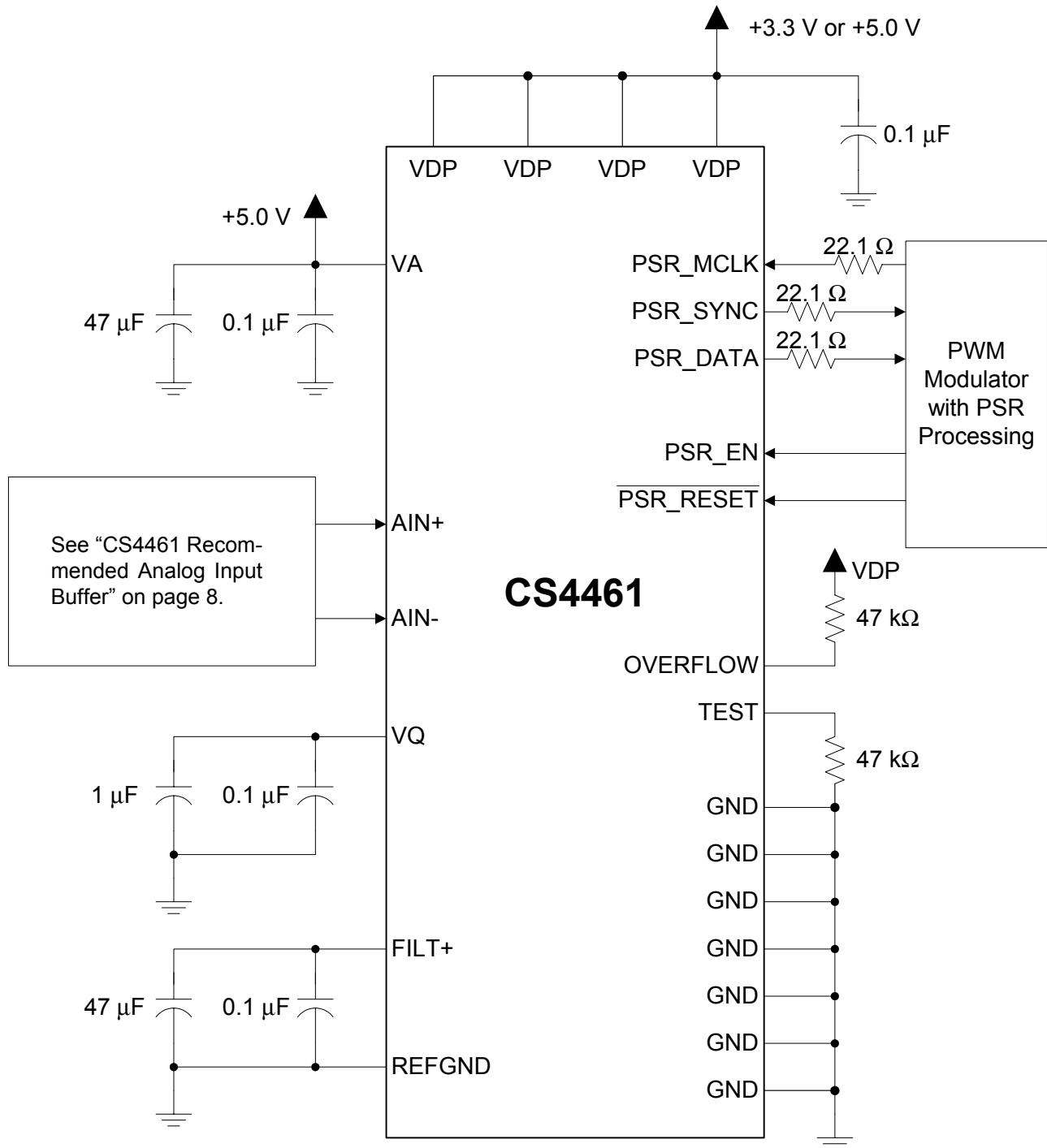

Figure 1. Typical Connection Diagram

## 4. APPLICATIONS

### 4.1 Digital Connections

PSR\_MCLK provides the system clock for the CS4461. PSR\_SYNC and PSR\_DATA provide the output of the modulator to the class-D modulator with feedback capabilities. Series damping resistors should be used on PSR\_MCLK, PSR\_SYNC, and PSR\_DATA to minimize noise. These should be placed as close as possible to their signal source. The pin labeled TEST should also be pulled low to GND through a 47 kΩ resistor to minimize noise coupling into the ADC modulator.

### 4.2 Analog Connections

The analog modulator samples the input at PSR\_MCLK/4 (6.144 MHz with PSR\_MCLK=24.576 MHz). [Figure 2](#) shows the suggested analog input filter. This filter topology will correctly buffer the power supply's AC and DC components for PSR processing by the class-D modulator. The use of capacitors which have a large voltage coefficient (such as general purpose ceramics) must be avoided since these can degrade signal linearity. COG dielectrics should be used wherever possible. R1 and R2 should be used to scale VP (class-D amplifier high voltage power supply) to less than the CS4461 maximum AIN+/AIN- input voltage (3.9 V).

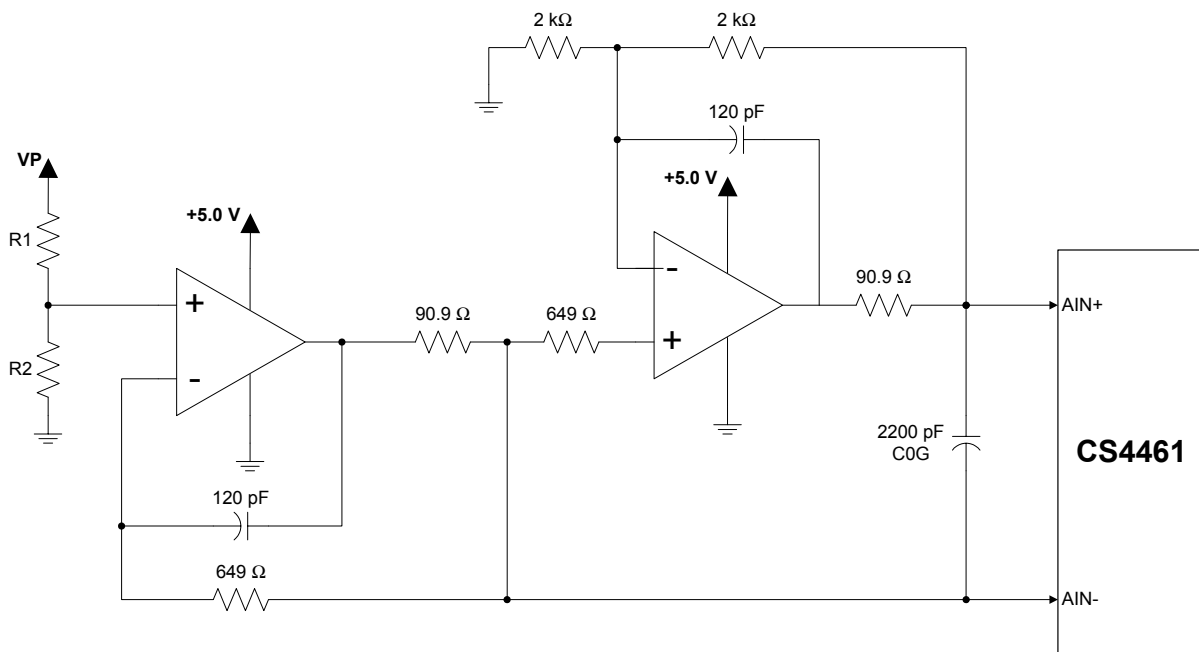

**Figure 2. CS4461 Recommended Analog Input Buffer**

The following equation can be used to scale R1 and R2:

$$2 * (VP * (1 + \%VP\_Ripple)) * (R2 / (R1 + R2)) < 3.9 V$$

Example (VP = 40 V, %VP\_Ripple = 4%):

$$2 * (40 * (1 + 0.04)) * (1.96 k\Omega / (40.2 k\Omega + 1.96 k\Omega)) = 3.87 V$$



### 4.3 Power-Up Sequence

Reliable power-up can be accomplished by keeping the device in reset until the power supplies and clocks are stable. It is also recommended that reset be enabled if the analog or digital supplies drop below the minimum specified operating voltages to prevent power glitch related issues.

The internal reference voltage must be stable for the device to produce valid data. Therefore, there is a delay between the release of reset and the generation of valid output, due to the finite output impedance of FILT+ and the presence of the external capacitance.

### 4.4 Overflow Detection

The CS4461 includes modulator overflow detection, indicated on pin 15,  $\overline{\text{OVERFLOW}}$  (open drain, active low).  $\overline{\text{OVERFLOW}}$  will go to a logical low as soon as an overrange condition is detected. The data will remain low until the condition is cleared.

### 4.5 Grounding and Power Supply Decoupling

As with any high resolution converter, the CS4461 requires careful attention to power supply and grounding arrangements if its potential performance is to be realized. Figure 1 shows the recommended power arrangements, with VA and VDP connected to clean supplies. VDP, which powers the digital logic, may be run from the system logic supply or may be powered from the analog supply via a resistor. In this case, no additional devices should be powered from VDP. Decoupling capacitors should be as near to the ADC as possible, with the low value ceramic capacitor being the nearest. All signals, especially clocks, should be kept away from the FILT+ and VQ pins in order to avoid unwanted coupling into the modulator. The FILT+ and VQ decoupling capacitors, particularly the 0.1  $\mu\text{F}$ , must be positioned to minimize the electrical path from FILT+ to GND. The CDB44800 evaluation board demonstrates the optimum layout and power supply arrangements. To minimize digital noise, connect the ADC digital outputs only to CMOS inputs.

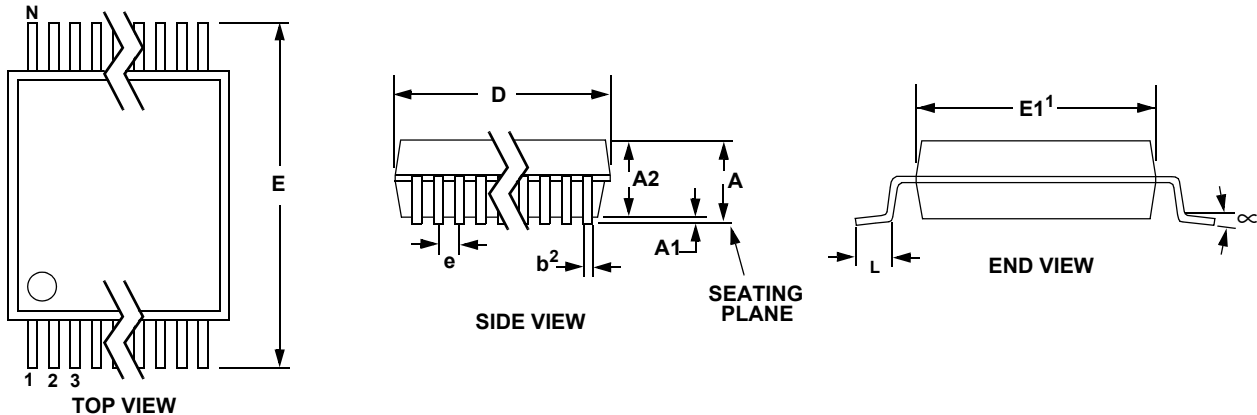
**5. PACKAGE DIMENSIONS**
**24L TSSOP (4.4 mm BODY) PACKAGE DRAWING**

DIM	INCHES			MILLIMETERS			NOTE
	MIN	NOM	MAX	MIN	NOM	MAX	
A	--	--	0.043	--	--	1.10	
A1	0.002	0.004	0.006	0.05	--	0.15	
A2	0.03346	0.0354	0.037	0.85	0.90	0.95	
b	0.00748	0.0096	0.012	0.19	0.245	0.30	2,3
D	0.303	0.307	0.311	7.70	7.80	7.90	1
E	0.248	0.2519	0.256	6.30	6.40	6.50	
E1	0.169	0.1732	0.177	4.30	4.40	4.50	1
e	--	0.026 BSC	--	--	0.65 BSC	--	
L	0.020	0.024	0.028	0.50	0.60	0.70	
$\mu$	0°	4°	8°	0°	4°	8°	

**JEDEC #: MO-153**

*Controlling Dimension is Millimeters.*

**Notes:**

1. "D" and "E1" are reference datums and do not include mold flash or protrusions, but do include mold mismatch and are measured at the parting line, mold flash or protrusions shall not exceed 0.20 mm per side.
2. Dimension "b" does not include dambar protrusion/intrusion. Allowable dambar protrusion shall be 0.13 mm total in excess of "b" dimension at maximum material condition. Dambar intrusion shall not reduce dimension "b" by more than 0.07 mm at least material condition.
3. These dimensions apply to the flat section of the lead between 0.10 and 0.25 mm from lead tips.

## 6. ORDERING INFORMATION

Product	Description	Package	Pb-Free	Grade	Temp Range	Container	Order #
CS4461	Multi-bit A/D for Class-D Real-time PSR Feedback	24-TSSOP	YES	Commercial	-10° to +70° C	Rail	CS4461-CZZ
						Tape & Reel	CS4461-CZZR
				Automotive	-40° to +85° C	Rail	CS4461-DZZ
						Tape & Reel	CS4461-DZZR
CDB44800	Evaluation board for the CS44800/600 and the CS4461	-	-	-	-	-	CDB44800

## 7. REVISION HISTORY

Release	Date	Changes
A1	May 2004	1st Advance Release
F1	September 2005	Updated ordering information

### Contacting Cirrus Logic Support

For all product questions and inquiries contact a Cirrus Logic Sales Representative.

To find the one nearest to you go to [www.cirrus.com](http://www.cirrus.com)

#### IMPORTANT NOTICE

Cirrus Logic, Inc. and its subsidiaries ("Cirrus") believe that the information contained in this document is accurate and reliable. However, the information is subject to change without notice and is provided "AS IS" without warranty of any kind (express or implied). Customers are advised to obtain the latest version of relevant information to verify, before placing orders, that information being relied on is current and complete. All products are sold subject to the terms and conditions of sale supplied at the time of order acknowledgment, including those pertaining to warranty, indemnification, and limitation of liability. No responsibility is assumed by Cirrus for the use of this information, including use of this information as the basis for manufacture or sale of any items, or for infringement of patents or other rights of third parties. This document is the property of Cirrus and by furnishing this information, Cirrus grants no license, express or implied under any patents, mask work rights, copyrights, trademarks, trade secrets or other intellectual property rights. Cirrus owns the copyrights associated with the information contained herein and gives consent for copies to be made of the information only for use within your organization with respect to Cirrus integrated circuits or other products of Cirrus. This consent does not extend to other copying such as copying for general distribution, advertising or promotional purposes, or for creating any work for resale.

CERTAIN APPLICATIONS USING SEMICONDUCTOR PRODUCTS MAY INVOLVE POTENTIAL RISKS OF DEATH, PERSONAL INJURY, OR SEVERE PROPERTY OR ENVIRONMENTAL DAMAGE ("CRITICAL APPLICATIONS"). CIRRUS PRODUCTS ARE NOT DESIGNED, AUTHORIZED OR WARRANTED FOR USE IN AIRCRAFT SYSTEMS, MILITARY APPLICATIONS, PRODUCTS SURGICALLY IMPLANTED INTO THE BODY, AUTOMOTIVE SAFETY OR SECURITY DEVICES, LIFE SUPPORT PRODUCTS OR OTHER CRITICAL APPLICATIONS. INCLUSION OF CIRRUS PRODUCTS IN SUCH APPLICATIONS IS UNDERSTOOD TO BE FULLY AT THE CUSTOMER'S RISK AND CIRRUS DISCLAIMS AND MAKES NO WARRANTY, EXPRESS, STATUTORY OR IMPLIED, INCLUDING THE IMPLIED WARRANTIES OF MERCHANTABILITY AND FITNESS FOR PARTICULAR PURPOSE, WITH REGARD TO ANY CIRRUS PRODUCT THAT IS USED IN SUCH A MANNER. IF THE CUSTOMER OR CUSTOMER'S CUSTOMER USES OR PERMITS THE USE OF CIRRUS PRODUCTS IN CRITICAL APPLICATIONS, CUSTOMER AGREES, BY SUCH USE, TO FULLY INDEMNIFY CIRRUS, ITS OFFICERS, DIRECTORS, EMPLOYEES, DISTRIBUTORS AND OTHER AGENTS FROM ANY AND ALL LIABILITY, INCLUDING ATTORNEYS' FEES AND COSTS, THAT MAY RESULT FROM OR ARISE IN CONNECTION WITH THESE USES.

Cirrus Logic, Cirrus, and the Cirrus Logic logo designs are trademarks of Cirrus Logic, Inc. All other brand and product names in this document may be trademarks or service marks of their respective owners.

## X-ON Electronics

Largest Supplier of Electrical and Electronic Components

*Click to view similar products for [Audio A/D Converter ICs](#) category:*

*Click to view products by [Cirrus](#) manufacturer:*

Other Similar products are found below :

[WM8781GEDSV](#) [WM8788GEDT](#) [WM8782SEDSV](#) [CS5346-CQZR](#) [CS4461-CZZ](#) [WM8782ASEDS/RV](#) [AD1877JRZ](#) [AD1974WBSTZ](#)  
[ADAU1977WBCPZ](#) [ADAU7112ACBZR7](#) [ADAU7118ACPZRL](#) [ADAU1979WBCPZ-RL](#) [CS5345-CQZ](#) [WM8950CGEFL/V](#) [CS5340-CZZ](#)  
[CS5340-DZZ](#) [CS5341-CZZ](#) [CS5342-CZZ](#) [CS5344-CZZ](#) [CS5346-CQZ](#) [CS5351-DZZ](#) [CS5361-KSZ](#) [CS5361-KZZ](#) [CS5364-DQZ](#) [CS5381-](#)  
[KSZ](#) [CS5381-KZZ](#) [CS53L21-CNZ](#) [CS53L30-CNZ](#) [WM8782ASEDS/V](#) [WM8786GEDS/RV](#) [6PADC3101TRGERQ1](#) [PCM1800E](#)  
[PCM1801U](#) [PCM1803ADB](#) [PCM1803ADBG4](#) [PCM1804DB](#) [PCM1804DBG4](#) [PCM1804DBR](#) [PCM1804S1IDBRQ1](#) [PCM1807PW](#)  
[PCM1807PWR](#) [PCM1808PW](#) [PCM1808PWG4](#) [PCM1808PWRG4](#) [PCM1851APJT](#) [PCM1851APJTR](#) [PCM1861DBT](#) [PCM1862DBTR](#)  
[PCM1864DBT](#) [PCM1865DBT](#)