

## Multi-Channel Audio Hub CODEC for Smartphones

### DESCRIPTION

The WM1811A<sup>[1]</sup> is a highly integrated ultra-low power hi-fi CODEC designed for smartphones and other portable devices rich in multimedia features.

An integrated stereo Class D speaker driver and Class W headphone driver minimize power consumption during audio playback.

The device requires only two voltage supplies, with all other internal supply rails generated from integrated LDOs.

Stereo full duplex asynchronous sample rate conversion and multi-channel digital mixing combined with powerful analogue mixing allow the device to support a huge range of different architectures and use cases.

A programmable parametric EQ provides speaker compensation in the digital playback paths. The dynamic range controller can be used in record or playback paths for maintaining a constant signal level, maximizing loudness and protecting speakers against overloading and clipping.

A smart digital microphone interface provides power regulation, a low jitter clock output and decimation filters for up to two digital microphones. Microphone activity detection with interrupt is available. Low power jack detection is supported via a dedicated input pin. Impedance sensing and measurement is provided for external accessory / push-button detection.

Fully differential internal architecture and on-chip RF noise filters ensure a very high degree of noise immunity. Active ground loop noise rejection and DC offset correction help prevent pop noise and suppress ground noise on the headphone outputs.

### FEATURES

- 24-bit 2-channel hi-fi DAC and 2-channel hi-fi ADC
- 100dB SNR during DAC playback ('A' weighted)
- Smart MIC interface
  - Power, clocking and data input for up to two digital MICs
  - High performance analogue MIC interface
  - MIC activity detect & interrupt allows processor to sleep
  - Low power jack detection support
  - Impedance sensing for accessory / push-button detection
- 2W stereo (2 x 2W) Class D speaker driver
- Capless Class W headphone drivers
  - Integrated charge pump
  - 5.3mW total power for DAC playback to headphones
- 4 Line outputs (single-ended or differential)
- BTL Earpiece driver
- Digital audio interfaces for multi-processor architecture
  - Asynchronous stereo duplex sample rate conversion
  - Powerful mixing and digital loopback functions
- ReTune™ Mobile 5-band, 4-channel parametric EQ
- Dynamic range controller
- Dual FLL provides all necessary clocks
  - Self-clocking modes allow processor to sleep
  - All standard sample rates from 8kHz to 96kHz
- Active noise reduction circuits
  - DC offset correction removes pops and clicks
  - Ground loop noise cancellation
- Integrated LDO regulators
- 80-ball W-CSP package (4.158 x 3.876 x 0.607mm)

### APPLICATIONS

- Smartphones and music phones
- Portable navigation
- Tablets, eBooks
- Portable Media Players

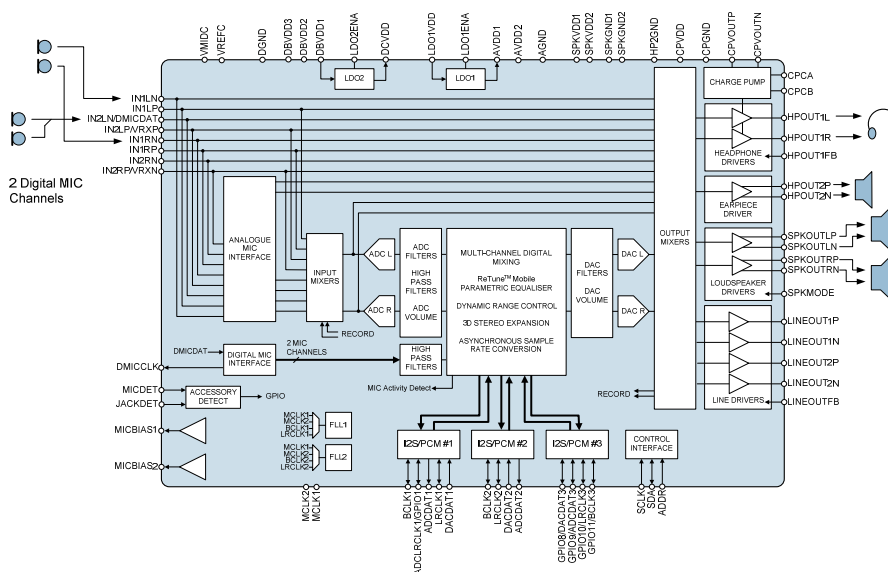

---

**TABLE OF CONTENTS**

<b>DESCRIPTION</b> .....	<b>1</b>
<b>FEATURES</b> .....	<b>1</b>
<b>APPLICATIONS</b> .....	<b>1</b>
<b>TABLE OF CONTENTS</b> .....	<b>2</b>
<b>BLOCK DIAGRAM</b> .....	<b>6</b>
<b>PIN CONFIGURATION</b> .....	<b>7</b>
<b>ORDERING INFORMATION</b> .....	<b>7</b>
<b>PIN DESCRIPTION</b> .....	<b>8</b>
<b>ABSOLUTE MAXIMUM RATINGS</b> .....	<b>11</b>
<b>RECOMMENDED OPERATING CONDITIONS</b> .....	<b>12</b>
<b>ELECTRICAL CHARACTERISTICS</b> .....	<b>13</b>
INPUT SIGNAL LEVEL .....	13
INPUT PIN RESISTANCE .....	14
PROGRAMMABLE GAINS .....	16
OUTPUT DRIVER CHARACTERISTICS .....	17
ADC INPUT PATH PERFORMANCE .....	18
DAC OUTPUT PATH PERFORMANCE .....	19
BYPASS PATH PERFORMANCE .....	21
MULTI-PATH CROSSTALK .....	23
DIGITAL INPUT / OUTPUT .....	25
DIGITAL FILTER CHARACTERISTICS .....	25
MICROPHONE BIAS CHARACTERISTICS .....	26
MISCELLANEOUS CHARACTERISTICS .....	27
TERMINOLOGY .....	28
<b>TYPICAL PERFORMANCE</b> .....	<b>29</b>
TYPICAL POWER CONSUMPTION .....	29
TYPICAL SIGNAL LATENCY .....	30
<b>SIGNAL TIMING REQUIREMENTS</b> .....	<b>31</b>
SYSTEM CLOCKS & FREQUENCY LOCKED LOOP (FLL) .....	31
AUDIO INTERFACE TIMING .....	32
DIGITAL MICROPHONE (DMIC) INTERFACE TIMING .....	32
DIGITAL AUDIO INTERFACE - MASTER MODE .....	33
DIGITAL AUDIO INTERFACE - SLAVE MODE .....	34
DIGITAL AUDIO INTERFACE - TDM MODE .....	35
CONTROL INTERFACE TIMING .....	36
<b>DEVICE DESCRIPTION</b> .....	<b>37</b>
INTRODUCTION .....	37
ANALOGUE INPUT SIGNAL PATH .....	39
MICROPHONE INPUTS .....	40
MICROPHONE BIAS CONTROL .....	40
MICROPHONE ACCESSORY DETECT .....	42
LINE AND VOICE CODEC INPUTS .....	42
INPUT PGA ENABLE .....	43
INPUT PGA CONFIGURATION .....	44
INPUT PGA VOLUME CONTROL .....	45
INPUT MIXER ENABLE .....	49
INPUT MIXER CONFIGURATION AND VOLUME CONTROL .....	49
DIGITAL MICROPHONE INTERFACE .....	53
DIGITAL PULL-UP AND PULL-DOWN .....	56

<b>ANALOGUE TO DIGITAL CONVERTER (ADC)</b> .....	<b>56</b>
ADC CLOCKING CONTROL .....	57
<b>DIGITAL CORE ARCHITECTURE</b> .....	<b>58</b>
<b>DIGITAL MIXING</b> .....	<b>60</b>
AUDIO INTERFACE 1 (AIF1) OUTPUT DIGITAL MIXING .....	61
DIGITAL SIDETONE VOLUME AND FILTER CONTROL .....	61
DAC OUTPUT DIGITAL MIXING .....	63
AUDIO INTERFACE 2 (AIF2) OUTPUT DIGITAL MIXING .....	64
DIGITAL VOLUME (DAC AND AIF2 OUTPUT PATHS) .....	65
DIGITAL VOLUME SOFT MUTE AND SOFT UN-MUTE .....	68
ULTRASONIC (4FS) AIF OUTPUT MODE .....	70
<b>DYNAMIC RANGE CONTROL (DRC)</b> .....	<b>71</b>
DRC COMPRESSION / EXPANSION /LIMITING .....	72
GAIN LIMITS .....	73
DYNAMIC CHARACTERISTICS .....	74
ANTI-CLIP CONTROL .....	74
QUICK RELEASE CONTROL .....	74
SIGNAL ACTIVITY DETECT .....	74
DRC REGISTER CONTROLS .....	75
<b>RETUNE™ MOBILE PARAMETRIC EQUALIZER (EQ)</b> .....	<b>81</b>
DEFAULT MODE (5-BAND PARAMETRIC EQ) .....	81
RETUNE™ MOBILE MODE .....	83
EQ FILTER CHARACTERISTICS .....	84
<b>3D STEREO EXPANSION</b> .....	<b>85</b>
<b>DIGITAL VOLUME AND FILTER CONTROL</b> .....	<b>86</b>
AIF1 - OUTPUT PATH VOLUME CONTROL .....	86
AIF1 - OUTPUT PATH HIGH PASS FILTER .....	88
AIF1 - INPUT PATH VOLUME CONTROL .....	89
AIF1 - INPUT PATH SOFT MUTE CONTROL .....	91
AIF1 - INPUT PATH NOISE GATE CONTROL .....	91
AIF1 - INPUT PATH MONO MIX CONTROL .....	92
AIF2 - OUTPUT PATH VOLUME CONTROL .....	92
AIF2 - OUTPUT PATH HIGH PASS FILTER .....	93
AIF2 - INPUT PATH VOLUME CONTROL .....	94
AIF2 - INPUT PATH SOFT MUTE CONTROL .....	95
AIF2 - INPUT PATH NOISE GATE CONTROL .....	96
AIF2- INPUT PATH MONO MIX CONTROL .....	96
<b>DIGITAL TO ANALOGUE CONVERTER (DAC)</b> .....	<b>97</b>
DAC CLOCKING CONTROL .....	97
<b>ANALOGUE OUTPUT SIGNAL PATH</b> .....	<b>99</b>
OUTPUT SIGNAL PATHS ENABLE .....	100
HEADPHONE SIGNAL PATHS ENABLE .....	101
OUTPUT MIXER CONTROL .....	104
SPEAKER MIXER CONTROL .....	108
OUTPUT SIGNAL PATH VOLUME CONTROL .....	110
SPEAKER BOOST MIXER .....	115
EARPIECE DRIVER MIXER .....	115
LINE OUTPUT MIXERS .....	116
<b>CHARGE PUMP</b> .....	<b>120</b>
<b>DC SERVO</b> .....	<b>122</b>
DC SERVO ENABLE AND START-UP .....	122
GPIO / INTERRUPT OUTPUTS FROM DC SERVO .....	124
<b>ANALOGUE OUTPUTS</b> .....	<b>125</b>
SPEAKER OUTPUT CONFIGURATIONS .....	125
HEADPHONE OUTPUT CONFIGURATIONS .....	128

EARPIECE DRIVER OUTPUT CONFIGURATIONS .....	129
LINE OUTPUT CONFIGURATIONS .....	129
<b>EXTERNAL ACCESSORY DETECTION .....</b>	<b>132</b>
JACK DETECT .....	132
MICROPHONE / ACCESSORY DETECT .....	135
EXTERNAL ACCESSORY DETECTION CLOCKING .....	140
EXTERNAL ACCESSORY DETECTION WITH LOW FREQUENCY SYCLK .....	140
<b>GENERAL PURPOSE INPUT/OUTPUT .....</b>	<b>141</b>
GPIO CONTROL .....	141
GPIO FUNCTION SELECT .....	142
BUTTON DETECT (GPIO INPUT) .....	144
LOGIC '1' AND LOGIC '0' OUTPUT (GPIO OUTPUT) .....	144
INTERRUPT (IRQ) STATUS OUTPUT .....	144
OVER-TEMPERATURE DETECTION .....	144
MICROPHONE ACCESSORY STATUS DETECTION .....	145
FREQUENCY LOCKED LOOP (FLL) LOCK STATUS OUTPUT .....	145
SAMPLE RATE CONVERTER (SRC) LOCK STATUS OUTPUT .....	145
DYNAMIC RANGE CONTROL (DRC) SIGNAL ACTIVITY DETECTION .....	146
DIGITAL CORE FIFO ERROR STATUS DETECTION .....	147
OPCLK CLOCK OUTPUT .....	148
FLL CLOCK OUTPUT .....	148
<b>INTERRUPTS .....</b>	<b>149</b>
<b>DIGITAL AUDIO INTERFACE .....</b>	<b>153</b>
MASTER AND SLAVE MODE OPERATION .....	154
OPERATION WITH TDM .....	154
AUDIO DATA FORMATS (NORMAL MODE) .....	155
AUDIO DATA FORMATS (TDM MODE) .....	158
<b>DIGITAL AUDIO INTERFACE CONTROL .....</b>	<b>160</b>
AIF1 - MASTER / SLAVE AND TRI-STATE CONTROL .....	160
AIF1 - SIGNAL PATH ENABLE .....	161
AIF1 - BCLK AND LRCLK CONTROL .....	161
AIF1 - DIGITAL AUDIO DATA CONTROL .....	164
AIF1 - MONO MODE .....	166
AIF1 - COMPANDING .....	166
AIF1 - LOOPBACK .....	168
AIF1 - DIGITAL PULL-UP AND PULL-DOWN .....	168
AIF2 - MASTER / SLAVE AND TRI-STATE CONTROL .....	168
AIF2 - SIGNAL PATH ENABLE .....	169
AIF2 - BCLK AND LRCLK CONTROL .....	170
AIF2 - DIGITAL AUDIO DATA CONTROL .....	172
AIF2 - MONO MODE .....	173
AIF2 - COMPANDING .....	174
AIF2 - LOOPBACK .....	174
AIF2 - DIGITAL PULL-UP AND PULL-DOWN .....	175
AIF3 - SIGNAL PATH CONFIGURATION AND TRI-STATE CONTROL .....	176
AIF3 - BCLK AND LRCLK CONTROL .....	178
AIF3 - DIGITAL AUDIO DATA CONTROL .....	179
AIF3 - COMPANDING .....	180
AIF3 - LOOPBACK .....	180
<b>CLOCKING AND SAMPLE RATES .....</b>	<b>181</b>
AIF1CLK ENABLE .....	182
AIF1 CLOCKING CONFIGURATION .....	183
AIF2CLK ENABLE .....	185
AIF2 CLOCKING CONFIGURATION .....	185
MISCELLANEOUS CLOCK CONTROLS .....	186

BCLK AND LRCLK CONTROL.....	189
CONTROL INTERFACE CLOCKING .....	190
FREQUENCY LOCKED LOOP (FLL).....	190
FREE-RUNNING FLL CLOCK.....	196
GPIO OUTPUTS FROM FLL .....	197
EXAMPLE FLL CALCULATION.....	198
EXAMPLE FLL SETTINGS.....	199
<b>SAMPLE RATE CONVERSION.....</b>	<b>200</b>
SAMPLE RATE CONVERTER 1 (SRC1).....	200
SAMPLE RATE CONVERTER 2 (SRC2).....	200
SAMPLE RATE CONVERTER RESTRICTIONS .....	201
SAMPLE RATE CONVERTER CONFIGURATION ERROR INDICATION .....	201
<b>CONTROL INTERFACE .....</b>	<b>202</b>
<b>POP SUPPRESSION CONTROL.....</b>	<b>205</b>
DISABLED LINE OUTPUT CONTROL.....	205
LINE OUTPUT DISCHARGE CONTROL .....	206
VMID REFERENCE DISCHARGE CONTROL.....	206
INPUT VMID CLAMPS .....	206
<b>LDO REGULATORS .....</b>	<b>207</b>
<b>REFERENCE VOLTAGES AND MASTER BIAS .....</b>	<b>209</b>
<b>POWER MANAGEMENT .....</b>	<b>211</b>
<b>THERMAL SHUTDOWN.....</b>	<b>215</b>
<b>POWER ON RESET .....</b>	<b>216</b>
<b>SOFTWARE RESET AND DEVICE ID.....</b>	<b>218</b>
<b>REGISTER MAP.....</b>	<b>219</b>
REGISTER BITS BY ADDRESS .....	230
<b>APPLICATIONS INFORMATION .....</b>	<b>312</b>
<b>RECOMMENDED EXTERNAL COMPONENTS.....</b>	<b>312</b>
AUDIO INPUT PATHS.....	312
HEADPHONE OUTPUT PATH.....	313
EARPIECE DRIVER OUTPUT PATH.....	314
LINE OUTPUT PATHS .....	314
POWER SUPPLY DECOUPLING .....	315
CHARGE PUMP COMPONENTS .....	316
MICROPHONE BIAS CIRCUIT .....	316
EXTERNAL ACCESSORY DETECTION COMPONENTS.....	318
CLASS D SPEAKER CONNECTIONS.....	320
RECOMMENDED EXTERNAL COMPONENTS DIAGRAM .....	321
<b>DIGITAL AUDIO INTERFACE CLOCKING CONFIGURATIONS .....</b>	<b>323</b>
<b>PCB LAYOUT CONSIDERATIONS.....</b>	<b>326</b>
CLASS D LOUDSPEAKER CONNECTION .....	326
<b>PACKAGE DIMENSIONS.....</b>	<b>327</b>
<b>IMPORTANT NOTICE .....</b>	<b>328</b>
ADDRESS:.....	328
<b>REVISION HISTORY .....</b>	<b>329</b>

BLOCK DIAGRAM

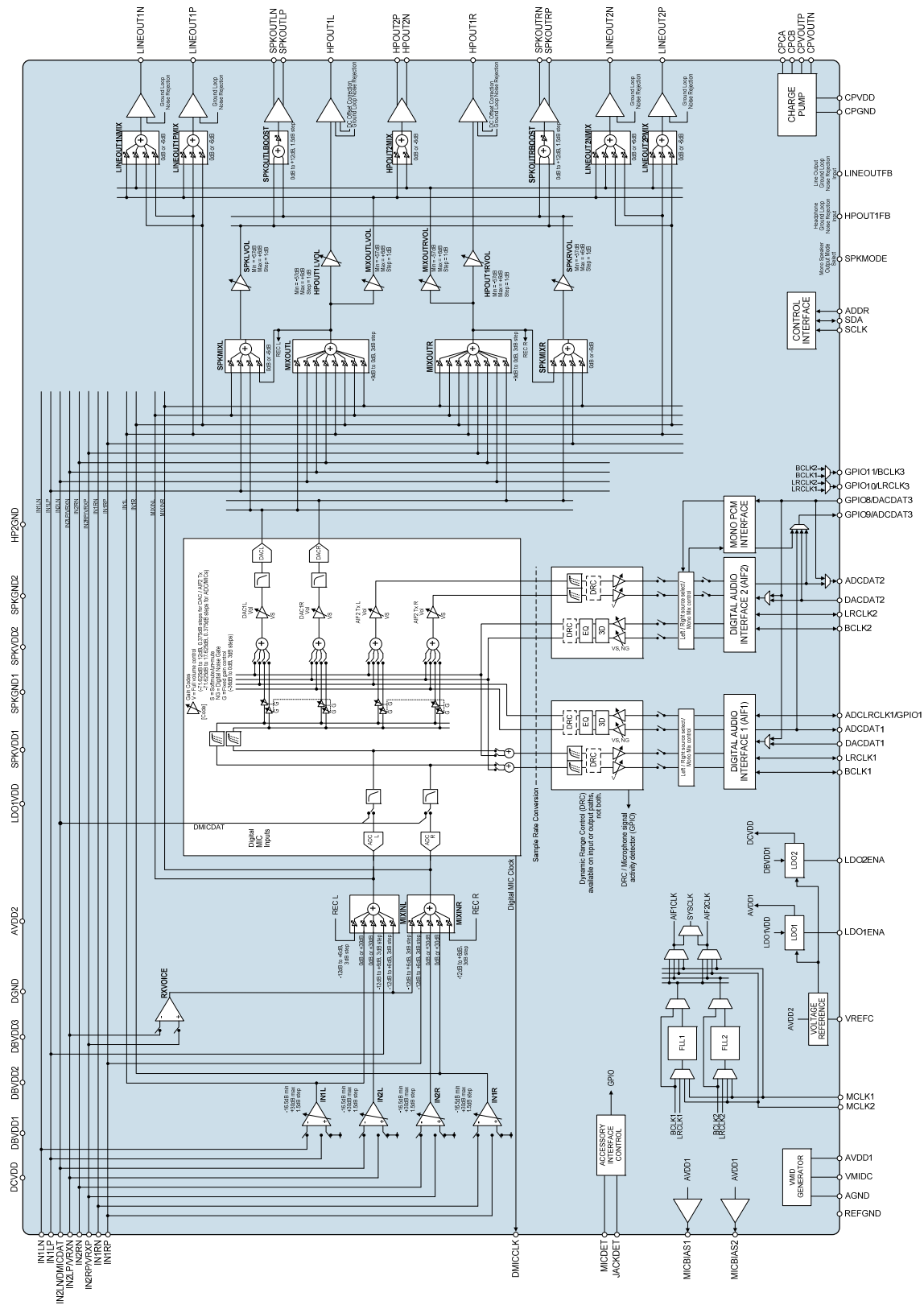

**PIN CONFIGURATION**

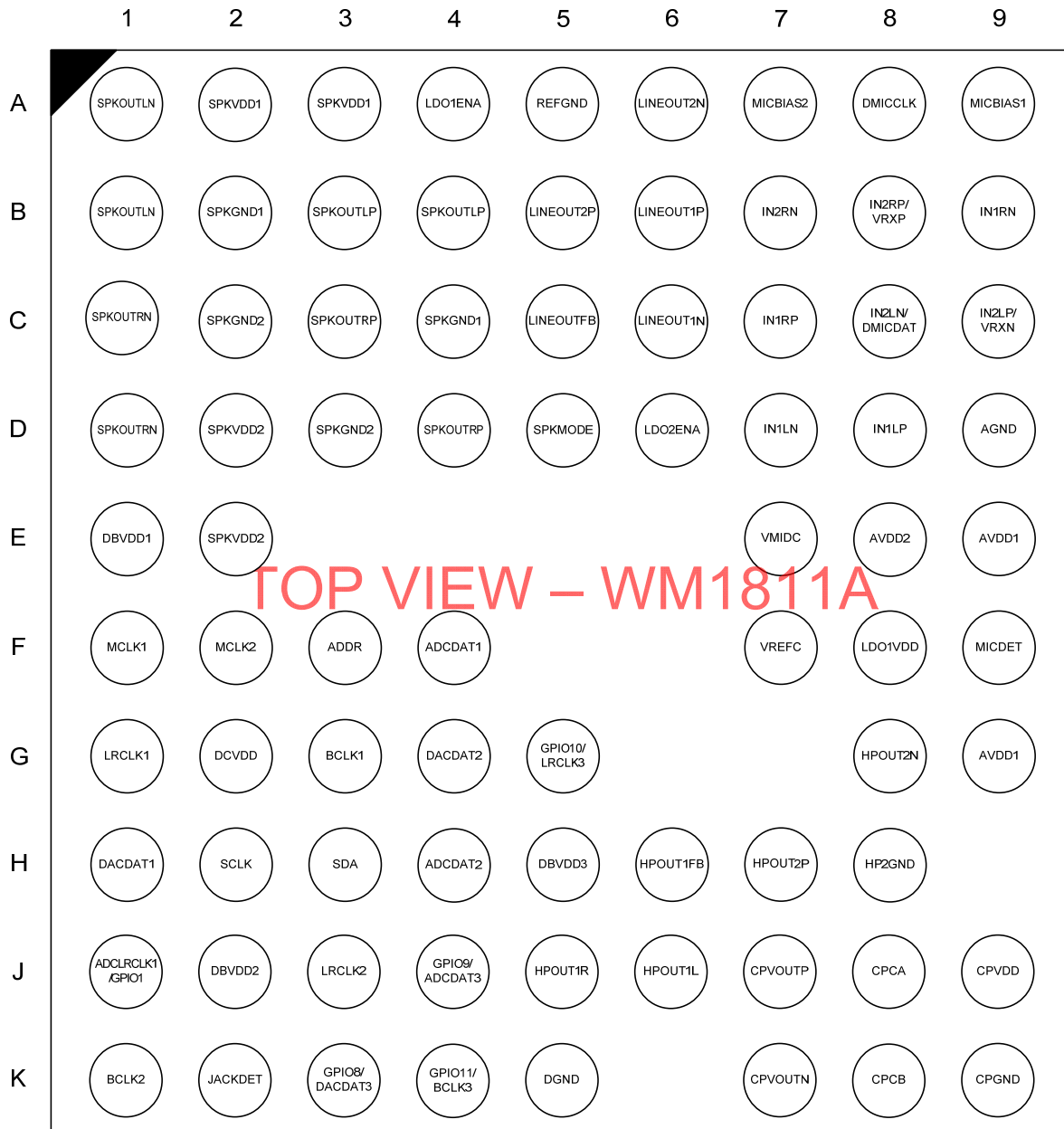

**ORDERING INFORMATION**

ORDER CODE	TEMPERATURERANGE	PACKAGE	MOISTURE SENSITIVITY LEVEL	PEAK SOLDERING TEMPERATURE
WM1811AECS/R	-40°C to +85°C	80-ball W-CSP (Pb-free, Tape and reel)	MSL1	260°C

**Note:**

Reel quantity = 5000

## PIN DESCRIPTION

A description of each pin on the WM1811A is provided below.

Note that a table detailing the associated power domain for every input and output pin is provided on the following page.

Note that, where multiple pins share a common name, these pins should be tied together on the PCB.

PIN NO	NAME	TYPE	DESCRIPTION
F4	ADCDAT1	Digital Output	Audio interface 1 ADC digital audio data
H4	ADCDAT2	Digital Output	Audio interface 2 ADC digital audio data
J1	ADCLRCLK1/ GPIO1	Digital Input / Output	Audio interface 1 ADC left / right clock / General Purpose pin GPIO 1
F3	ADDR	Digital Input	2-wire (I2C) address select
D9	AGND	Supply	Analogue ground (Return path for AVDD1, AVDD2 and LDO1VDD)
E9, G9	AVDD1	Supply / Analogue Output	Analogue core supply / LDO1 Output
E8	AVDD2	Supply	Bandgap and Jack Detect reference, analogue Class D and FLL supply
G3	BCLK1	Digital Input / Output	Audio interface 1 bit clock
K1	BCLK2	Digital Input / Output	Audio interface 2 bit clock
J8	CPCA	Analogue Output	Charge pump fly-back capacitor pin
K8	CPCB	Analogue Output	Charge pump fly-back capacitor pin
K9	CPGND	Supply	Charge pump ground (Return path for CPVDD)
J9	CPVDD	Supply	Charge pump supply
K7	CPVOUTN	Analogue Output	Charge pump negative supply decoupling pin (HPOUT1L, HPOUT1R)
J7	CPVOUTP	Analogue Output	Charge pump positive supply decoupling pin (HPOUT1L, HPOUT1R)
H1	DACDAT1	Digital Input	Audio interface 1 DAC digital audio data
G4	DACDAT2	Digital Input	Audio interface 2 DAC digital audio data
E1	DBVDD1	Supply	Digital buffer (I/O) supply (core functions and Audio Interface 1)
J2	DBVDD2	Supply	Digital buffer (I/O) supply (for Audio Interface 2)
H5	DBVDD3	Supply	Digital buffer (I/O) supply (for Audio Interface 3)
G2	DCVDD	Supply / Analogue Output	Digital core supply / LDO2 output
K5	DGND	Supply	Digital ground (Return path for DCVDD, DBVDD1, DBVDD2, DBVDD3)
A8	DMICCLK	Digital Output	Digital MIC clock output
G5	GPIO10/ LRCLK3	Digital Input / Output	General Purpose pin GPIO 10 / Audio interface 3 left / right clock
K4	GPIO11/ BCLK3	Digital Input / Output	General Purpose pin GPIO 11 / Audio interface 3 bit clock
K3	GPIO8/ DACDAT3	Digital Input / Output	General Purpose pin GPIO 8 / Audio interface 3 DAC digital audio data
J4	GPIO9/ ADCDAT3	Digital Input / Output	General Purpose pin GPIO 9 / Audio interface 3 ADC digital audio data
H8	HP2GND	Supply	Analogue ground
H6	HPOUT1FB	Analogue Input	HPOUT1L and HPOUT1R ground loop noise rejection feedback
J6	HPOUT1L	Analogue Output	Left headphone output
J5	HPOUT1R	Analogue Output	Right headphone output
G8	HPOUT2N	Analogue Output	Earpiece speaker inverted output
H7	HPOUT2P	Analogue Output	Earpiece speaker non-inverted output
D7	IN1LN	Analogue Input	Left channel single-ended MIC input / Left channel negative differential MIC input
D8	IN1LP	Analogue Input	Left channel line input / Left channel positive differential MIC input
B9	IN1RN	Analogue Input	Right channel single-ended MIC input / Right channel negative differential MIC input



PIN NO	NAME	TYPE	DESCRIPTION
C7	IN1RP	Analogue Input	Right channel line input / Right channel positive differential MIC input
C8	IN2LN/ DMICDAT	Analogue Input / Digital Input	Left channel line input / Left channel negative differential MIC input / Digital MIC data input
C9	IN2LP/VRXN	Analogue Input	Left channel line input / Left channel positive differential MIC input / Mono differential negative input (RXVOICE -)
B7	IN2RN	Analogue Input	Right channel line input / Right channel negative differential MIC input
B8	IN2RP/VRXP	Analogue Input	Left channel line input / Left channel positive differential MIC input / Mono differential positive input (RXVOICE +)
K2	JACKDET	Analogue Input	Headphone jack detection input
A4	LDO1ENA	Digital Input	Enable pin for LDO1
F8	LDO1VDD	Supply	Supply for LDO1
D6	LDO2ENA	Digital Input	Enable pin for LDO2
C6	LINEOUT1N	Analogue Output	Negative mono line output / Positive left or right line output
B6	LINEOUT1P	Analogue Output	Positive mono line output / Positive left line output
A6	LINEOUT2N	Analogue Output	Negative mono line output / Positive left or right line output
B5	LINEOUT2P	Analogue Output	Positive mono line output / Positive left line output
C5	LINEOUTFB	Analogue Input	Line output ground loop noise rejection feedback
G1	LRCLK1	Digital Input / Output	Audio interface 1 left / right clock
J3	LRCLK2	Digital Input / Output	Audio interface 2 left / right clock
F1	MCLK1	Digital Input	Master clock 1
F2	MCLK2	Digital Input	Master clock 2
A9	MICBIAS1	Analogue Output	Microphone bias 1
A7	MICBIAS2	Analogue Output	Microphone bias 2
F9	MICDET	Analogue Input	Microphone & accessory sense input
A5	REFGND	Supply	Analogue ground
H2	SCLK	Digital Input	Control interface clock input
H3	SDA	Digital Input / Output	Control interface data input and output / acknowledge output
B2, C4	SPKGND1	Supply	Ground for speaker driver (Return path for SPKVDD1)
C2, D3	SPKGND2	Supply	Ground for speaker driver (Return path for SPKVDD2)
D5	SPKMODE	Digital Input	Mono / Stereo speaker mode select
A1, B1	SPKOUTLN	Analogue Output	Left speaker negative output
B3, B4	SPKOUTLP	Analogue Output	Left speaker positive output
C1, D1	SPKOUTRN	Analogue Output	Right speaker negative output
C3, D4	SPKOUTRP	Analogue Output	Right speaker positive output
A2, A3	SPKVDD1	Supply	Supply for speaker driver 1 (Left channel)
D2, E2	SPKVDD2	Supply	Supply for speaker driver 2 (Right channel)
E7	VMIDC	Analogue Output	Midrail voltage decoupling capacitor
F7	VREFC	Analogue Output	Bandgap reference decoupling capacitor

The following table identifies the power domain and ground reference associated with each of the input / output pins.

PIN NO	NAME	POWER DOMAIN	GROUND DOMAIN
F4	ADCDA1	DBVDD1	DGND
H4	ADCDA2	DBVDD2	DGND
J1	ADCLRCLK1/GPIO1	DBVDD1	DGND
F3	ADDR	DBVDD1	DGND
G3	BCLK1	DBVDD1	DGND
K1	BCLK2	DBVDD2	DGND
H1	DACDA1	DBVDD1	DGND
G4	DACDA2	DBVDD2	DGND
A8	DMICCLK	MICBIAS1	AGND
K3	GPIO8/DACDA3	DBVDD3	DGND
J4	GPIO9/DACDA3	DBVDD3	DGND
G5	GPIO10/LRCLK3	DBVDD3	DGND
K4	GPIO11/BCLK3	DBVDD3	DGND
J6	HPOUT1L	CPVOUTP, CPVOUTN	CPGND
J5	HPOUT1R	CPVOUTP, CPVOUTN	CPGND
G8	HPOUT2N	AVDD1	HP2GND
H7	HPOUT2P	AVDD1	HP2GND
D7	IN1LN	AVDD1	AGND
D8	IN1LP	AVDD1	AGND
B9	IN1RN	AVDD1	AGND
C7	IN1RP	AVDD1	AGND
C8	IN2LN/DMICDAT	AVDD1 (IN2LN) or MICBIAS1 (DMICDAT)	AGND
C9	IN2LP/VRXN	AVDD1	AGND
B7	IN2RN	AVDD1	AGND
B8	IN2RP/VRXP	AVDD1	AGND
K2	JACKDET	AVDD2	AGND
A4	LDO1ENA	DBVDD1	DGND
D6	LDO2ENA	DBVDD1	DGND
C6	LINEOUT1N	AVDD1	AGND
B6	LINEOUT1P	AVDD1	AGND
A6	LINEOUT2N	AVDD1	AGND
B5	LINEOUT2P	AVDD1	AGND
G1	LRCLK1	DBVDD1	DGND
J3	LRCLK2	DBVDD2	DGND
F1	MCLK1	DBVDD1	DGND
F2	MCLK2	DBVDD1	DGND
F9	MICDET	MICBIAS2	AGND
H2	SCLK	DBVDD1	DGND
H3	SDA	DBVDD1	DGND
D5	SPKMODE	DBVDD1	DGND
A1, B1	SPKOUTLN	SPKVDD1	SPKGND1
B3, B4	SPKOUTLP	SPKVDD1	SPKGND1
C1, D1	SPKOUTRN	SPKVDD2	SPKGND2
C3, D4	SPKOUTRP	SPKVDD2	SPKGND2

## ABSOLUTE MAXIMUM RATINGS

Absolute Maximum Ratings are stress ratings only. Permanent damage to the device may be caused by continuously operating at or beyond these limits. Device functional operating limits and guaranteed performance specifications are given under Electrical Characteristics at the test conditions specified.



ESD Sensitive Device. This device is manufactured on a CMOS process. It is therefore generically susceptible to damage from excessive static voltages. Proper ESD precautions must be taken during handling and storage of this device.

Wolfson tests its package types according to IPC/JEDEC J-STD-020 for Moisture Sensitivity to determine acceptable storage conditions prior to surface mount assembly. These levels are:

MSL1 = unlimited floor life at <30°C / 85% Relative Humidity. Not normally stored in moisture barrier bag.

MSL2 = out of bag storage for 1 year at <30°C / 60% Relative Humidity. Supplied in moisture barrier bag.

MSL3 = out of bag storage for 168 hours at <30°C / 60% Relative Humidity. Supplied in moisture barrier bag.

The Moisture Sensitivity Level for each package type is specified in Ordering Information.

CONDITION	MIN	MAX
Supply voltages (AVDD1, DBVDD2, DBVDD3)	-0.3V	+4.5V
Supply voltages (AVDD2, DCVDD, DBVDD1)	-0.3V	+2.5V
Supply voltages (CPVDD)	-0.3V	+2.2V
Supply voltages (SPKVDD1, SPKVDD2, LDO1VDD)	-0.3V	+7.0V
Voltage range digital inputs (DBVDD1 domain)	AGND -0.3V	DBVDD1 +0.3V
Voltage range digital inputs (DBVDD2 domain)	AGND -0.3V	DBVDD2 +0.3V
Voltage range digital inputs (DBVDD3 domain)	AGND -0.3V	DBVDD3 +0.3V
Voltage range digital inputs (DMICDAT)	AGND -0.3V	AVDD1 +0.3V
Voltage range analogue inputs (AVDD1 domain)	AGND -0.3V	AVDD1 +0.3V
Voltage range analogue inputs (MICDET, LINEOUTFB)	AGND -0.3V	AVDD1 +0.3V
Voltage range analogue inputs (HPOUT1FB)	AGND -0.3V	AGND +0.3V
Voltage range analogue inputs (JACKDET)	CPVOUTN - 0.3V	AVDD2 +0.3V
See note 1		
Ground (DGND, CPGND, SPKGND1, SPKGND2, REFGND, HP2GND)	AGND -0.3V	AGND +0.3V
Operating temperature range, T <sub>A</sub>	-40°C	+85°C
Junction temperature, T <sub>JMAX</sub>	-40°C	+150°C
Storage temperature after soldering	-65°C	+150°C

### Notes:

1. CPVOUTN is an internal supply rail, generated by the WM1811A Charge Pump. The CPVOUTN voltage may vary between AGND and -CPVDD.

**RECOMMENDED OPERATING CONDITIONS**

PARAMETER	SYMBOL	MIN	TYP	MAX	UNIT
Digital supply range (Core) See notes 7, 8	DCVDD	1.00	1.05	2.0	V
Digital supply range (I/O)	DBVDD1	1.62	1.8	2.0	V
Digital supply range (I/O)	DBVDD2, DBVDD3	1.62	1.8	3.6	V
Analogue supply 1 range See notes 3, 4, 5, 6	AVDD1	2.4	3.0	3.3	V
Analogue supply 2 range	AVDD2	1.71	1.8	2.0	V
Charge Pump supply range	CPVDD	1.71	1.8	2.0	V
Speaker supply range	SPKVDD1, SPKVDD2	2.7	5.0	5.5	V
LDO1 supply range	LDO1VDD	2.7	5.0	5.5	V
Ground	DGND, AGND, CPGND, SPKGND1, SPKGND2, REFGND, HP2GND		0		V
Power supply rise time See notes 9, 10, 11	All supplies	1			µs
Operating temperature range	T <sub>A</sub>	-40		85	°C

**Notes:**

1. Analogue, digital and speaker grounds must always be within 0.3V of AGND.
2. There is no power sequencing requirement; the supplies may be enabled in any order.
3. AVDD1 must be less than or equal to SPKVDD1 and SPKVDD2.
4. An internal LDO (powered by LDO1VDD) can be used to provide the AVDD1 supply.
5. When AVDD1 is supplied externally (not from LDO1), the LDO1VDD voltage must be greater than or equal to AVDD1.
6. The WM1811A can operate with AVDD1 tied to 0V; power consumption may be reduced, but the analogue audio functions will not be supported.
7. An internal LDO (powered by DBVDD1) can be used to provide the DCVDD supply.
8. When DCVDD is supplied externally (not from LDO2), the DBVDD1 voltage must be greater than or equal to DCVDD.
9. DCVDD and AVDD1 minimum rise times do not apply when these domains are powered using the internal LDOs.
10. The specified minimum power supply rise times assume a minimum decoupling capacitance of 100nF per pin. However, Wolfson strongly advises that the recommended decoupling capacitors are present on the PCB and that appropriate layout guidelines are observed (see "Applications Information" section).
11. The specified minimum power supply rise times also assume a maximum PCB inductance of 10nH between decoupling capacitor and pin.

## ELECTRICAL CHARACTERISTICS

### INPUT SIGNAL LEVEL

#### Test Conditions

AVDD1 = 3.0V.

With the exception of the condition(s) noted above, the following electrical characteristics are valid across the full range of recommended operating conditions.

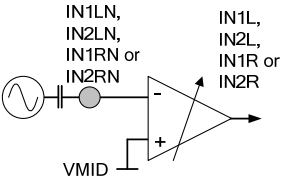
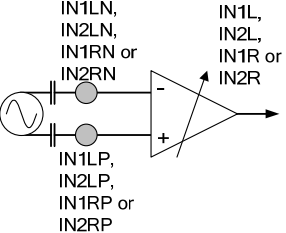
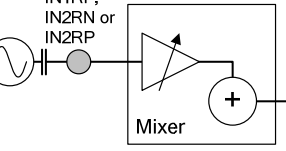
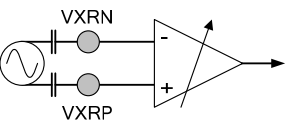
PARAMETER		TEST CONDITIONS		MIN	TYP	MAX	UNIT
A1	Full-Scale PGA Input Signal Level  See notes 1, 2, 3 and 4	Single-ended PGA input			1.0 0		Vrms dBV
		Differential PGA input			1.0 0		Vrms dBV
A2	Full-Scale Line Input Signal Level  See notes 1, 2, 3 and 4	Single-ended Line input to MIXINL/R, SPKMIXL/R or MIXOUTL/R mixers			1.0 0		Vrms dBV
		Differential mono line input on VRXP/VRXN to RXVOICE			1.0 0		Vrms dBV

#### Notes:

1. The full-scale input signal level changes in proportion with AVDD1. It is calculated as AVDD1/3.0.
2. When mixing line inputs, input PGA outputs and DAC outputs the total signal must not exceed 1.0Vrms (0dBV).
3. A 1.0Vrms differential signal equates to 0.5Vrms/-6dBV per input.
4. A sinusoidal input signal is assumed.

**INPUT PIN RESISTANCE**

**Test Conditions**

T<sub>A</sub> = +25°C.

With the exception of the condition(s) noted above, the following electrical characteristics are valid across the full range of recommended operating conditions.

PARAMETER		TEST CONDITIONS		MIN	TYP	MAX	UNIT
B1	PGA Input Resistance Differential Mode	Gain = -16.5dB (INnx_VOL=00h)			53		kΩ
	See note 5	Gain = 0dB (INnx_VOL=0Bh)			25		kΩ
	See "Applications Information" for details of Input resistance at all PGA Gain settings.	Gain = +30dB (INnx_VOL=1Fh)			1.3		kΩ
B2	PGA Input Resistance Single-Ended Mode	Gain = -16.5dB (INnx_VOL=00h)			58		kΩ
	See note 5	Gain = 0dB (INnx_VOL=0Bh)			36		kΩ
	See "Applications Information" for details of Input resistance at all PGA Gain settings.	Gain = +30dB (INnx_VOL=1Fh)			2.5		kΩ
B3	Line Input Resistance See note 5	IN1LP to MIXINL, or IN1RP to MIXINR Gain = -12dB (IN1xP_MIXINx_VOL=001)			56		kΩ
		IN1LP to MIXINL, or IN1RP to MIXINR Gain = 0dB (IN1xP_MIXINx_VOL=101)			18		kΩ
		IN1LP to MIXINL, or IN1RP to MIXINR Gain = +6dB (IN1xP_MIXINx_VOL=111)			9.8		kΩ
		IN1LP to MIXINL, or IN1RP to MIXINR Gain = +15dB (IN1xP_MIXINx_VOL=111, IN1xP_MIXINx_BOOST=1)			3.7		kΩ
		IN1LPto SPKMIXL, or IN1RP to SPKMIXR (SPKATTN = -12dB)			89		kΩ
		IN1LPto SPKMIXL, or IN1RP to SPKMIXR (SPKATTN = 0dB)			27		kΩ
		IN2LN, IN2RN, IN2LP or IN2RP to MIXOUTL or MIXOUTR Gain = -9dB (*MIXOUTx_VOL=011)			43		kΩ
		IN2LN, IN2RN, IN2LP or IN2RP to MIXOUTL or MIXOUTR Gain = 0dB			18		kΩ

**Test Conditions**

T<sub>A</sub> = +25°C.

With the exception of the condition(s) noted above, the following electrical characteristics are valid across the full range of recommended operating conditions.

PARAMETER	TEST CONDITIONS	MIN	TYP	MAX	UNIT
	(*MIXOUTx_VOL=000)				
	RXVOICE to MIXINLorMIXINR Gain = -12dB (IN2LRP_MIXINx_VOL=001)		48		kΩ
	RXVOICE to MIXINLorMIXINR Gain = 0dB (IN2LRP_MIXINx_VOL=101)		12		kΩ
	RXVOICE to MIXINLorMIXINR Gain = +6dB (IN2LRP_MIXINx_VOL=111)		6.0		kΩ

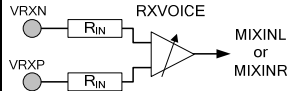

**Note 5:** Input resistance will be seen in parallel with the resistance of other enabled input paths from the same pins

**PROGRAMMABLE GAINS****Test Conditions**

The following electrical characteristics are valid across the full range of recommended operating conditions.

PARAMETER		TEST CONDITIONS	MIN	TYP	MAX	UNIT
<b>Input PGAs (IN1L, IN2L, IN1R and IN2R)</b>						
C1	Minimum Programmable Gain	Guaranteed monotonic		-16.5		dB
C2	Maximum Programmable Gain			+30		dB
C3	Programmable Gain Step Size			1.5		dB
<b>Input Mixers (MIXINL and MIXINR)</b>						
C6	Minimum Programmable Gain	Input PGA signal paths		0		dB
C7	Maximum Programmable Gain			+30		dB
C8	Programmable Gain Step Size			30		dB
C9	Minimum Programmable Gain	Direct IN1xP input signal paths (Note the available gain settings are -12, -9, -6, -3, 0, +3, +6, +15dB)		-12		dB
C10	Maximum Programmable Gain			+15		dB
C11	Programmable Gain Step Size			3		dB
	Minimum Programmable Gain	MIXOUTx Record signal paths		-12		dB
	Maximum Programmable Gain			+6		dB
	Programmable Gain Step Size			3		dB
C12	Minimum Programmable Gain	RXVOICE (VRXP-VRXN) signal paths		-12		dB
C13	Maximum Programmable Gain			+6		dB
C14	Programmable Gain Step Size			3		dB
<b>Output Mixers (MIXOUTL and MIXOUTR)</b>						
C17	Minimum Programmable Gain			-9		dB
C18	Maximum Programmable Gain			0		dB
C19	Programmable Gain Step Size			3		dB
<b>Speaker Mixers (SPKMIXL and SPKMIXR)</b>						
C21	Minimum Programmable Gain			-6		dB
C22	Maximum Programmable Gain			0		dB
C23	Programmable Gain Step Size			6		dB
<b>Output PGAs (HPOUT1LVOL, HPOUT1RVOL, MIXOUTLVOL, MIXOUTRVOL, SPKLVOL and SPKRVOL)</b>						
C25	Minimum Programmable Gain	Guaranteed monotonic		-57		dB
C26	Maximum Programmable Gain			+6		dB
C27	Programmable Gain Step Size			1		dB
<b>Line Output Drivers (LINEOUT1NMIX, LINEOUT1PMIX, LINEOUT2NMIX and LINEOUT2PMIX)</b>						
C29	Minimum Programmable Gain			-6		dB
C30	Maximum Programmable Gain			0		dB
C31	Programmable Gain Step Size			6		dB
<b>EarpieceDriver (HPOUT2MIX)</b>						
C33	Minimum Programmable Gain			-6		dB
C34	Maximum Programmable Gain			0		dB
C35	Programmable Gain Step Size			6		dB
<b>Speaker Output Drivers (SPKOUTLBOOST and SPKOUTRBOOST)</b>						
C38	Minimum Programmable Gain	(Note the available gain settings are 0, +1.5, +3, +4.5, +6, +7.5, +9, +12dB)		0		dB
C39	Maximum Programmable Gain			+12		dB
C40	Programmable Gain Step Size			1.5		dB



## OUTPUT DRIVER CHARACTERISTICS

### Test Conditions

The following electrical characteristics are valid across the full range of recommended operating conditions.

PARAMETER		TEST CONDITIONS	MIN	TYP	MAX	UNIT
<b>Line Output Driver (LINEOUT1P, LINEOUT1N, LINEOUT2P, LINEOUT2N)</b>						
	Load resistance		2			kΩ
	Load capacitance	Direct connection			100	pF
		Connection via 1kΩ series resistor			2000	
	Output discharge resistance	LINEOUTn_DISCH=1, VROI=0		8		kΩ
		LINEOUTn_DISCH=1, VROI=1, LINEOUTn_ENA=0		500		Ω
<b>Headphone Output Driver (HPOUT1L, HPOUT1R)</b>						
	Load resistance	Normal operation	15			Ω
		Device survival with load applied indefinitely (see note 6)		100		
	Load capacitance				500	pF
<b>Earpiece Output Driver (HPOUT2L, HPOUT2R)</b>						
	Load resistance		15			Ω
	Load capacitance	Direct connection			200	pF
	DC offset across load			±5		mV
<b>Speaker Output Driver (SPKOUTLP, SPKOUTLN, SPKOUTRP, SPKOUTRN)</b>						
	Load resistance		4			Ω
	Maximum output power (per channel)	Design rating		2		W
	DC offset across load			±5		mV
	SPKVDD leakage current	Sum of $I_{SPKVDD1} + I_{SPKVDD2}$		1		μA

**Note 6:** In typical applications, the PCB trace resistance, jack contact resistance and ESR of any series passive components (eg. inductor or ferrite bead) are sufficient to provide this minimum resistance; additional series components are not required.

**ADC INPUT PATH PERFORMANCE**

**Test Conditions**

AVDD1=3.0V (powered from LDO1), DCVDD=1.05V (powered from LDO2), AVDD2=DBVDD1=DBVDD2=DBVDD3=CPVDD=1.8V, LDO1VDD=SPKVDD1=SPKVDD2=5V, DGND=AGND=CPGND=SPKGND1=SPKGND2=HP2GND=0V, T<sub>A</sub> = +25°C, 1kHz sinusoidal signal, f<sub>s</sub> = 48kHz, PGA gain = 0dB, 24-bit audio data unless otherwise stated.

PARAMETER	TEST CONDITIONS		MIN	TYP	MAX	UNIT				
D1	<b>Line Inputs to ADC via MIXINL and MIXINR</b>									
	SNR	A-weighted					94		dB	
	THD	-1dBV input					-83		dB	
	THD+N	-1dBV input					-81		dB	
	Channel Separation (L/R)						-100		dB	
	PSRR (SPKVDDn, LDO1VDD)	100mV (pk-pk) 217Hz					92		dB	
	PSRR (AVDD2, CPVDD, DBVDDn)	100mV (pk-pk) 217Hz					94		dB	
D2	<b>Record Path (DACs to ADCs via MIXINL and MIXINR)</b>									
	SNR	A-weighted					92		dB	
	THD	-1dBFS input					-74		dB	
	THD+N	-1dBFS input					-72		dB	
	Channel Separation (L/R)						-95		dB	
	PSRR (SPKVDDn, LDO1VDD)	100mV (pk-pk) 217Hz					97		dB	
	PSRR (AVDD2, CPVDD, DBVDDn)	100mV (pk-pk) 217Hz					94		dB	
D3	<b>Input PGAs to ADC via MIXINL or MIXINR</b>									
	SNR	A-weighted					84	95		dB
	THD	-1dBV input					-82	-72	dB	
	THD+N	-1dBV input					-80	-70	dB	
	Channel Separation (L/R)						-100		dB	
	PSRR (SPKVDDn, LDO1VDD)	100mV (pk-pk) 217Hz					100		dB	
	PSRR (AVDD2, CPVDD, DBVDDn)	100mV (pk-pk) 217Hz					95		dB	
	CMRR	Input PGA=-16.5dB					1V (pk-pk) 217Hz	49		dB
		Input PGA = 0dB					1V (pk-pk) 217Hz	58		dB
		Input PGA = +30dB					1V (pk-pk) 217Hz	73		dB
Note that the Input PGA gain is controlled using the IN <sub>n</sub> _VOL registers.										

**Test Conditions**

AVDD1=3.0V (powered from LDO1), DCVDD=1.05V (powered from LDO2), AVDD2=DBVDD1=DBVDD2=DBVDD3=CPVDD=1.8V, LDO1VDD=SPKVDD1=SPKVDD2=5V, DGND=AGND=CPGND=SPKGND1=SPKGND2=HP2GND=0V, T<sub>A</sub> = +25°C, 1kHz sinusoidal signal, fs = 48kHz, PGA gain = 0dB, 24-bit audio data unless otherwise stated.

PARAMETER	TEST CONDITIONS	MIN	TYP	MAX	UNIT
D4	<b>RXVOICE to ADCL or ADCR</b>				
SNR	A-weighted		94		dB
THD	-1dBV input		-84		dB
THD+N	-1dBV input		-82		dB
PSRR (SPKVDDn, LDO1VDD)	100mV (pk-pk) 217Hz		102		dB
PSRR (AVDD2, CPVDD, DBVDDn)	100mV (pk-pk) 217Hz		97		dB
CMRR	Input PGA = -12dB 1V (pk-pk) 217Hz		56		dB
	Input PGA = 0dB 1V (pk-pk) 217Hz		63		
	Input PGA = +6dB 1V (pk-pk) 217Hz		61		
Note that the Input PGA gain is controlled using the IN2LRP_MIXINx_VOL registers.					

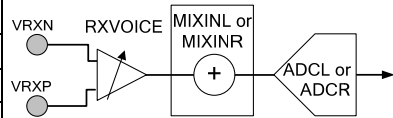

**DAC OUTPUT PATH PERFORMANCE**

**Test Conditions**

AVDD1=3.0V (powered from LDO1), DCVDD=1.05V (powered from LDO2), AVDD2=DBVDD1=DBVDD2=DBVDD3=CPVDD=1.8V, LDO1VDD=SPKVDD1=SPKVDD2=5V, DGND=AGND=CPGND=SPKGND1=SPKGND2=HP2GND=0V, T<sub>A</sub> = +25°C, 1kHz sinusoidal signal, fs = 48kHz, PGA gain = 0dB, 24-bit audio data unless otherwise stated.

PARAMETER	TEST CONDITIONS	MIN	TYP	MAX	UNIT
E1	<b>DAC to Single-Ended Line Output (Load = 10kΩ // 50pF)</b>				
SNR	A-weighted		93		dB
THD	0dBFS input		-82		dB
THD+N	0dBFS input		-80		dB
Channel Separation (L/R)			-90		dB
PSRR (SPKVDDn, LDO1VDD)	100mV (pk-pk) 217Hz		85		dB
PSRR (AVDD2, CPVDD, DBVDDn)	100mV (pk-pk) 217Hz		95		dB
LINEOUTFB rejection	LINEOUTn_FB=1, 100mV (pk-pk) 217Hz		38		dB
E2	<b>DAC to Differential Line Output (Load = 10kΩ // 50pF)</b>				
SNR	A-weighted		97		dB
THD	0dBFS input		-82		dB
THD+N	0dBFS input		-80		dB
Channel Separation (L/R)			-90		dB
PSRR (SPKVDDn, LDO1VDD)	100mV (pk-pk) 217Hz		87		dB
PSRR (AVDD2, CPVDD, DBVDDn)	100mV (pk-pk) 217Hz		88		dB

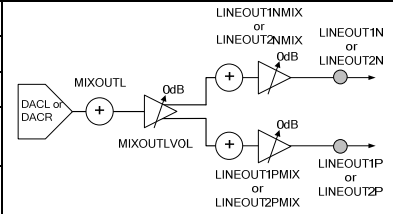
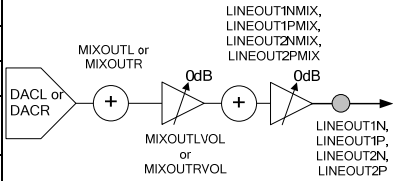

**Test Conditions**

AVDD1=3.0V (powered from LDO1), DCVDD=1.05V (powered from LDO2), AVDD2=DBVDD1=DBVDD2=DBVDD3=CPVDD=1.8V, LDO1VDD=SPKVDD1=SPKVDD2=5V, DGND=AGND=CPGND=SPKGND1=SPKGND2=HP2GND=0V,  $T_A = +25^\circ\text{C}$ , 1kHz sinusoidal signal,  $f_s = 48\text{kHz}$ , PGA gain = 0dB, 24-bit audio data unless otherwise stated.

PARAMETER	TEST CONDITIONS		MIN	TYP	MAX	UNIT	
E5	<b>DAC to Headphone on HPOUT1L or HPOUT1R (Load = 32Ω)</b>						
	SNR (A-weighted)	DAC_OSR128=1			100		dB
		DAC_OSR128=0			97		dB
	THD	$P_O=20\text{mW}$			-74		dB
	THD+N	$P_O=20\text{mW}$			-72		dB
	THD	$P_O=5\text{mW}$			-76		dB
	THD+N	$P_O=5\text{mW}$			-74		dB
	Channel Separation (L/R)				-95		dB
	PSRR (SPKVDDn, LDO1VDD)	100mV (pk-pk) 217Hz			96		dB
	PSRR (AVDD2, CPVDD, DBVDDn)	100mV (pk-pk) 217Hz			89		dB
HPOUT1FB rejection	100mV (pk-pk) 217Hz			29		dB	
E6	<b>DAC to Headphone on HPOUT1L or HPOUT1R (Load = 16Ω)</b>						
	SNR (A-weighted)	DAC_OSR128=1		90	100		dB
		DAC_OSR128=0			97		dB
	THD	$P_O=20\text{mW}$			-82		dB
	THD+N	$P_O=20\text{mW}$			-80		dB
	THD	$P_O=5\text{mW}$			-83	-73	dB
	THD+N	$P_O=5\text{mW}$			-81	-71	dB
	Channel Separation (L/R)				-95		dB
	PSRR (SPKVDDn, LDO1VDD)	100mV (pk-pk) 217Hz			98		dB
	PSRR (AVDD2, CPVDD, DBVDDn)	100mV (pk-pk) 217Hz			88		dB
HPOUT1FB rejection	100mV (pk-pk) 217Hz			29		dB	
E9	<b>DAC to Earpiece Driver (Load = 16Ω BTL)</b>						
	SNR	A-weighted			97		dB
	THD	$P_O=50\text{mW}$			-71		dB
	THD+N	$P_O=50\text{mW}$			-69		dB
	PSRR (SPKVDDn, LDO1VDD)	100mV (pk-pk) 217Hz			95		dB
	PSRR (AVDD2, CPVDD, DBVDDn)	100mV (pk-pk) 217Hz			96		dB

**Test Conditions**

AVDD1=3.0V (powered from LDO1), DCVDD=1.05V (powered from LDO2), AVDD2=DBVDD1=DBVDD2=DBVDD3=CPVDD=1.8V, LDO1VDD=SPKVDD1=SPKVDD2=5V, DGND=AGND=CPGND=SPKGND1=SPKGND2=HP2GND=0V, T<sub>A</sub> = +25°C, 1kHz sinusoidal signal, f<sub>s</sub> = 48kHz, PGA gain = 0dB, 24-bit audio data unless otherwise stated.

PARAMETER		TEST CONDITIONS		MIN	TYP	MAX	UNIT
E12	<b>DAC to Speaker Outputs (Load = 8Ω + 22μH BTL, Stereo Mode)</b>						
	<b>+12dB boost (SPKOUTx_BOOST = 111)</b>						
	SNR	A-weighted		85	94		dB
	THD	P <sub>O</sub> =0.5W			-65		dB
	THD+N	P <sub>O</sub> =0.5W			-63	-53	dB
	THD	P <sub>O</sub> =1.0W			-70		dB
	THD+N	P <sub>O</sub> =1.0W			-68		dB
	Channel Separation (L/R)				-80		dB
PSRR (SPKVDDn, LDO1VDD)	100mV (pk-pk) 217Hz			72		dB	
PSRR (AVDD2, CPVDD, DBVDDn)	100mV (pk-pk) 217Hz			78		dB	

**BYPASS PATH PERFORMANCE**

**Test Conditions**

AVDD1=3.0V (powered from LDO1), DCVDD=1.05V (powered from LDO2), AVDD2=DBVDD1=DBVDD2=DBVDD3=CPVDD=1.8V, LDO1VDD=SPKVDD1=SPKVDD2=5V, DGND=AGND=CPGND=SPKGND1=SPKGND2=HP2GND=0V, T<sub>A</sub> = +25°C, 1kHz sinusoidal signal, f<sub>s</sub> = 48kHz, PGA gain = 0dB, 24-bit audio data unless otherwise stated.

PARAMETER		TEST CONDITIONS		MIN	TYP	MAX	UNIT
F1	<b>Input PGA to Differential Line Output (Load = 10kΩ // 50pF)</b>						
	SNR	A-weighted			100		dB
	THD	0dBV output			-90		dB
	THD+N	0dBV output			-87		dB
	PSRR (SPKVDDn, LDO1VDD)	100mV (pk-pk) 217Hz			90		dB
	PSRR (AVDD2, CPVDD, DBVDDn)	100mV (pk-pk) 217Hz			90		dB
CMRR	Input PGA = 0dB 1V (pk-pk) 217Hz			58		dB	
Note that the Input PGA gain is controlled using the INnx_VOL registers.							
F3	<b>Input PGA to Headphone via MIXOUTL or MIXOUTR (Load = 16Ω)</b>						
	SNR	A-weighted			98		dB
	THD	P <sub>O</sub> =20mW			-89		dB
	THD+N	P <sub>O</sub> =20mW			-87		dB
	THD	P <sub>O</sub> =5mW			-86		dB
	THD+N	P <sub>O</sub> =5mW			-84		dB
	Channel Separation (L/R)				-95		dB
	PSRR (SPKVDDn, LDO1VDD)	100mV (pk-pk) 217Hz			100		dB
	PSRR (AVDD2, CPVDD, DBVDDn)	100mV (pk-pk) 217Hz			89		dB
CMRR	Input PGA = 0dB 1V (pk-pk) 217Hz			58		dB	
Note that the Input PGA gain is controlled using the INnx_VOL registers.							

**Test Conditions**

AVDD1=3.0V (powered from LDO1), DCVDD=1.05V (powered from LDO2), AVDD2=DBVDD1=DBVDD2=DBVDD3=CPVDD=1.8V, LDO1VDD=SPKVDD1=SPKVDD2=5V, DGND=AGND=CPGND=SPKGND1=SPKGND2=HP2GND=0V, T<sub>A</sub> = +25°C, 1kHz sinusoidal signal, f<sub>s</sub> = 48kHz, PGA gain = 0dB, 24-bit audio data unless otherwise stated.

PARAMETER	TEST CONDITIONS		MIN	TYP	MAX	UNIT	
F2	<b>Line Input (IN2LP or IN2RP) to Headphone via MIXOUTL or MIXOUTR (Load = 16Ω)</b>						
	SNR	A-weighted			100		dB
	THD	P <sub>O</sub> =20mW			-86		dB
	THD+N	P <sub>O</sub> =20mW			-84		dB
	THD	P <sub>O</sub> =5mW			-84		dB
	THD+N	P <sub>O</sub> =5mW			-82		dB
	PSRR (SPKVDDn, LDO1VDD)	100mV (pk-pk) 217Hz			93		dB
	PSRR (AVDD2, CPVDD, DBVDDn)	100mV (pk-pk) 217Hz			87		dB
F4	<b>Line Input (IN2LN or IN2RN) to Headphone via MIXOUTL or MIXOUTR (Load = 16Ω)</b>						
	SNR	A-weighted			100		dB
	THD	P <sub>O</sub> =20mW			-84		dB
	THD+N	P <sub>O</sub> =20mW			-82		dB
	THD	P <sub>O</sub> =5mW			-82		dB
	THD+N	P <sub>O</sub> =5mW			-80		dB
	Channel Separation (L/R)				-95		dB
	PSRR (SPKVDDn, LDO1VDD)	100mV (pk-pk) 217Hz			94		dB
PSRR (AVDD2, CPVDD, DBVDDn)	100mV (pk-pk) 217Hz	87				dB	
F8	<b>Line Input to Speaker Outputs via SPKMIXL or SPKMIXR (Load = 8Ω + 22μHBTL, Stereo Mode) +12dB boost (SPKOUTx_BOOST = 111)</b>						
	SNR	A-weighted			93		dB
	THD	P <sub>O</sub> =0.5W			-62		dB
	THD+N	P <sub>O</sub> =0.5W			-60		dB
	THD	P <sub>O</sub> =1.0W			-67		dB
	THD+N	P <sub>O</sub> =1.0W			-65		dB
	PSRR (SPKVDDn, LDO1VDD)	100mV (pk-pk) 217Hz			68		dB
	PSRR (AVDD2, CPVDD, DBVDDn)	100mV (pk-pk) 217Hz			76		dB

**MULTI-PATH CROSSTALK**

**Test Conditions**

AVDD1=3.0V (powered from LDO1), DCVDD=1.05V (powered from LDO2),  
 AVDD2=DBVDD1=DBVDD2=DBVDD3=CPVDD=1.8V, LDO1VDD=SPKVDD1=SPKVDD2=5V,  
 DGND=AGND=CPGND=SPKGND1=SPKGND2=HP2GND=0V,  
 T<sub>A</sub> = +25°C, 1kHz sinusoidal signal, f<sub>s</sub> = 48kHz, PGA gain = 0dB, 24-bit audio data unless otherwise stated.

PARAMETER	TEST CONDITIONS	MIN	TYP	MAX	UNIT
<p>G1 Headset Voice Call:                      DAC/Headset to Tx Voice Separation</p> <p>1kHz 0dBFS DAC playback direct to HPOUT1L and HPOUT1R; Quiescent input on IN1LN/P or IN1RN/P (Gain=+12dB), differential line output; Measure crosstalk at differential line output</p>			85		dB
<p>G2 Speakerphone Voice Call:                      DAC/Speaker to Tx Voice Separation</p> <p>1kHz 0dBFS DAC playback to speakers, 1W/chan output; Quiescent input on IN1LN/P or IN1RN/P (Gain=+12dB), differential line output; Measure crosstalk at differential line output</p>			100		dB
<p>G3 Earpiece PCM Voice Call:                      RXVOICE to Tx Voice Separation</p> <p>f<sub>s</sub>=8kHz for ADC and DAC, DAC_SB_FILT=1; -5dBFS, DAC output to HPOUT2P-HPOUT2N; Quiescent input on input PGA (Gain=+12dB) to ADC via MIXINL or MIXINR; Measure crosstalk at ADC output</p>			110		dB
<p>G4 Speakerphone PCM Voice Call:                      DAC/Speaker to ADC Separation</p> <p>f<sub>s</sub>=8kHz for ADC and DAC, DAC_SB_FILT=1; 0dBFS DAC output to speaker (1W output); ADC record from input PGA (Gain=+30dB); Measure crosstalk on ADC output</p>			90		dB
<p>G5 Speakerphone PCM Voice Call:                      ADC to DAC/Speaker Separation</p> <p>f<sub>s</sub>=8kHz for ADC and DAC, DAC_SB_FILT=1; Quiescent DAC output to speaker; ADC record from input PGA (Gain=+30dB + 30dB boost); Measure crosstalk on speaker output</p>			95		dB

**Test Conditions**

AVDD1=3.0V (powered from LDO1), DCVDD=1.05V (powered from LDO2),  
 AVDD2=DBVDD1=DBVDD2=DBVDD3=CPVDD=1.8V, LDO1VDD=SPKVDD1=SPKVDD2=5V,  
 DGND=AGND=CPGND=SPKGND1=SPKGND2=HP2GND=0V,  
 T<sub>A</sub> = +25°C, 1kHz sinusoidal signal, fs = 48kHz, PGA gain = 0dB, 24-bit audio data unless otherwise stated.

PARAMETER	TEST CONDITIONS	MIN	TYP	MAX	UNIT
<p>G6 Earpiece Speaker Voice Call: Tx Voice and RXVOICE Separation</p> <p>1kHz Full scale differential input on VRXP-VRXN, output to HPOUT2P-HPOUT2N; Quiescent input on IN1LN/P or IN1RN/P (Gain=+12dB), differential line output; Measure crosstalk at differential line output</p>			100		dB
<p>G7 Headset Voice Call: Tx Voice and RXVOICE Separation</p> <p>1kHz full scale differential input on VRXP-VRXN via RXVOICE to MIXOUTL and MIXOUTR, output to HPOUT1L and HPOUT1R; Quiescent input on IN1LN/P or IN1RN/P (Gain=+12dB), differential line output; Measure crosstalk at differential line output</p>			90		dB
<p>G8 Stereo Line Record and Playback: DAC/Headset to ADC Separation</p> <p>-5dBFS input to DACs, playback to HPOUT1L and HPOUT1R; ADC record from line input; Measure crosstalk on ADC output</p>			95		dB



**DIGITAL INPUT / OUTPUT****Test Conditions**

The following electrical characteristics are valid across the full range of recommended operating conditions.

PARAMETER	TEST CONDITIONS	MIN	TYP	MAX	UNIT
<b>Digital Input / Output (except DMICDAT and DMICCLK)</b>					
<b>Digital I/O is referenced to DBVDD1, DBVDD2 or DBVDD3. See "Pin Description" for the domain applicable to each pin.</b>					
H16	Input HIGH Level, $V_{IH}$		$0.8 \times DBVDDn$		V
H17	Input LOW Level, $V_{IL}$			$0.2 \times DBVDDn$	V
Note that digital input pins should not be left unconnected / floating.					
H18	Output HIGH Level, $V_{OH}$	$I_{OH}=1mA$	$0.8 \times DBVDDn$		V
H19	Output LOW Level, $V_{OL}$	$I_{OL}=-1mA$		$0.2 \times DBVDDn$	V
H20	Input capacitance		10		pF
H21	Input leakage		-0.9	0.9	$\mu A$
<b>Digital Microphone Input / Output (DMICDAT and DMICCLK)</b>					
H22	DMICDAT input HIGH Level, $V_{IH}$		$0.65 \times MICBIAS1$		V
H23	DMICDAT input LOW Level, $V_{IL}$			$0.35 \times MICBIAS1$	V
H24	DMICCLK output HIGH Level, $V_{OH}$	$I_{OH}=1mA$	$0.8 \times MICBIAS1$		V
H25	DMICCLK output LOW Level, $V_{OL}$	$I_{OL}=-1mA$		$0.2 \times MICBIAS1$	V
H26	Input capacitance		10		pF
H27	Input leakage		-0.9	0.9	$\mu A$

**DIGITAL FILTER CHARACTERISTICS****Test Conditions**

The following electrical characteristics are valid across the full range of recommended operating conditions.

PARAMETER	TEST CONDITIONS	MIN	TYP	MAX	UNIT
<b>ADC Decimation Filter</b>					
	Passband	+/- 0.05dB	0		0.454 fs
		-6dB		0.5fs	
	Passband Ripple			+/- 0.05	dB
	Stopband		0.546 fs		
	Stopband Attenuation	$f > 0.546 fs$	85		dB
	Group Delay			2	ms
<b>DAC Interpolation Filter</b>					
	Passband	+/- 0.05dB	0		0.454 fs
		-6dB		0.5 fs	
	Passband Ripple		0.454 fs	+/- 0.05	dB
	Stopband		0.546 fs		
	Stopband Attenuation	$f > 0.546 fs$	85		dB
	Group Delay			2	ms

## MICROPHONE BIAS CHARACTERISTICS

## Test Conditions

AVDD1=3.0V (powered from LDO1), DCVDD=1.05V (powered from LDO2),  
 AVDD2=DBVDD1=DBVDD2=DBVDD3=CPVDD=1.8V, LDO1VDD=SPKVDD1=SPKVDD2=5V,  
 DGND=AGND=CPGND=SPKGND1=SPKGND2=HP2GND=0V, T<sub>A</sub> = +25°C, unless otherwise stated.

PARAMETER	TEST CONDITIONS	MIN	TYP	MAX	UNIT	
<b>Microphone Bias (MICBIAS1 and MICBIAS2)</b>						
Note - No capacitor on MICBIASn						
Note - In regulator mode, it is required that AVDD1 - V <sub>MICBIASn</sub> > 200mV						
H2	Bias Voltage Regulator mode (MICBn_MODE=0) Load current ≤ 1.0mA	MICBn_LVL = 000	-5%	1.5	+5%	V
		MICBn_LVL = 001	-5%	1.8	+5%	
		MICBn_LVL = 010	-5%	1.9	+5%	
		MICBn_LVL = 011	-5%	2.0	+5%	
		MICBn_LVL = 100	-5%	2.2	+5%	
		MICBn_LVL = 101	-5%	2.4	+5%	
		MICBn_LVL = 110	-5%	2.5	+5%	
		MICBn_LVL = 111	-5%	2.6	+5%	
	Bias Voltage Bypass mode (MICBn_MODE=1) Load current ≤ 3.6mA		AVDD1 - 80mV		AVDD1	V
H3	Bias Current	Regulator mode (MICBn_MODE=0)			2.4	mA
		Bypass mode (MICBn_MODE=1)			3.6	
H4	Output Noise Density	Regulator mode (MICBn_MODE=0), MICBn_LVL = 100, Load current = 1mA, Measured at 1kHz		60		nV/√Hz
H5	Integrated Noise Voltage	Regulator mode (MICBn_MODE=0), MICBn_LVL = 100, Load current = 1mA, 100Hz to 7kHz, A-weighted		4.5		μV <sub>RMS</sub>
H6	PSRR (AVDD1) 100mV (pk-pk) 217Hz	MICBn_LVL = 000		79		dB
		MICBn_LVL = 001		73		
		MICBn_LVL = 010		71		
		MICBn_LVL = 011		70		
		MICBn_LVL = 100		68		
		MICBn_LVL = 101		65		
		MICBn_LVL = 110		62		
		MICBn_LVL = 111		62		
	PSRR (AVDD2, CPVDD, DBVDDn) 100mV (pk-pk) 217Hz	MICBn_LVL = 000		95		dB
		MICBn_LVL = 001		95		
		MICBn_LVL = 010		95		
		MICBn_LVL = 011		97		
		MICBn_LVL = 100		95		
		MICBn_LVL = 101		95		
	MICBn_LVL = 110		94			
	MICBn_LVL = 111		92			
	Load capacitance	Regulator mode (MICBn_MODE=0)			50	pF
	Output discharge resistance	MICBn_ENA=0, MICBn_DISCH=1		20		kΩ

**MISCELLANEOUS CHARACTERISTICS****Test Conditions**

AVDD1=3.0V (powered from LDO1), DCVDD=1.05V (powered from LDO2),  
 AVDD2=DBVDD1=DBVDD2=DBVDD3=CPVDD=1.8V, LDO1VDD=SPKVDD1=SPKVDD2=5V,  
 DGND=AGND=CPGND=SPKGND1=SPKGND2=HP2GND=0V,  
 T<sub>A</sub> = +25°C, 1kHz sinusoidal signal, f<sub>s</sub> = 48kHz, PGA gain = 0dB, 24-bit audio data unless otherwise stated.

PARAMETER	TEST CONDITIONS	MIN	TYP	MAX	UNIT	
<b>Analogue Reference Levels</b>						
H1	VMID Midrail Reference Voltage	VMID_SEL = 01, 4.7μF capacitor on VMIDC	-3%	AVDD1/2	+3%	V
	VMID Start-Up time	VMID_SEL = 01, VMID_RAMP = 11, 4.7μF capacitor on VMIDC			50	ms
<b>External Accessory Detection</b>						
	Load impedance detection range (MICDET) 2.2kΩ (2%) MICBIAS2 resistor. Note these characteristics assume no other component is connected to MICDET. See "Applications Information" for recommended external components when a typical microphone is present.	for MICD_LVL[0] = 1	0		3	Ω
		for MICD_LVL[1] = 1	13.33		15.27	
		for MICD_LVL[2] = 1	27.16		30.96	
		for MICD_LVL[3] = 1	42.48		49.47	
		for MICD_LVL[4] = 1	65		85	
		for MICD_LVL[5] = 1	114		155.24	
		for MICD_LVL[6] = 1	191		329.87	
	Jack Detection input threshold voltage (JACKDET)	Jack insertion		0.5 x AVDD2		V
		Jack removal		0.85 x AVDD2		
<b>Frequency Locked Loops (FLLs)</b>						
H29	Lock time	F <sub>REF</sub> =32kHz, F <sub>OUT</sub> =12.288MHz		2.5		ms
		F <sub>REF</sub> =12MHz, F <sub>OUT</sub> =12.288MHz		300		μs
H30	Free-running mode start-up time			100		μs
H31	Free-running mode frequency accuracy	Reference supplied initially		+/-10		%
		No reference provided		+/-30		%

**Test Conditions**

AVDD1=3.0V (powered from LDO1), DCVDD=1.05V (powered from LDO2),  
 AVDD2=DBVDD1=DBVDD2=DBVDD3=CPVDD=1.8V, LDO1VDD=SPKVDD1=SPKVDD2=5V,  
 DGND=AGND=CPGND=SPKGND1=SPKGND2=HP2GND=0V,  
 T<sub>A</sub> = +25°C, 1kHz sinusoidal signal, fs = 48kHz, PGA gain = 0dB, 24-bit audio data unless otherwise stated.

PARAMETER		TEST CONDITIONS	MIN	TYP	MAX	UNIT
<b>LDO Regulators</b>						
H38	LDO1 Start-Up Time	4.7μF capacitor on AVDD1 1μF capacitor on VREFC			1.5	ms
	LDO1 Drop-Out voltage (LDO1VDD - AVDD1)				300	mV
	LDO1 PSRR (SPKVDD, LDO1VDD)	100mV (pk-pk) 217Hz, All LDO1 output settings		50		dB
	LDO1 PSRR (AVDD2, CPVDD, DBVDDn)	100mV (pk-pk) 217Hz, All LDO1 output settings		82		dB
H42	LDO2 Start-Up Time	1μF capacitor on DCVDD 1μF capacitor on VREFC			1.5	ms
	LDO2 PSRR (SPKVDD, LDO1VDD) 100mV (pk-pk) 217Hz	LDO2_VSEL = 01		82		dB
		LDO2_VSEL = 10		85		
		LDO2_VSEL = 11		83		
	LDO2 PSRR (AVDD2, CPVDD, DBVDDn) 100mV (pk-pk) 217Hz	LDO2_VSEL = 01		55		dB
		LDO2_VSEL = 10		66		
		LDO2_VSEL = 11		57		

**TERMINOLOGY**

1. Signal-to-Noise Ratio (dB) – SNR is a measure of the difference in level between the maximum full scale output signal and the output with no input signal applied.
2. Total Harmonic Distortion (dB) – THD is the level of the rms value of the sum of harmonic distortion products relative to the amplitude of the measured output signal.
3. Total Harmonic Distortion plus Noise (dB) – THD+N is the level of the rms value of the sum of harmonic distortion products plus noise in the specified bandwidth relative to the amplitude of the measured output signal.
4. Power Supply Rejection Ratio (dB) - PSRR is the ratio of a specified power supply variation relative to the output signal that results from it. PSRR is measured under quiescent signal path conditions.
5. Common Mode Rejection Ratio (dB) – CMRR is the ratio of a specified input signal (applied to both sides of a differential input), relative to the output signal that results from it.
6. Channel Separation (L/R) (dB) – left-to-right and right-to-left channel separation is the difference in level between the active channel (driven to maximum full scale output) and the measured signal level in the idle channel at the test signal frequency. The active channel is configured and supplied with an appropriate input signal to drive a full scale output, with signal measured at the output of the associated idle channel.
7. Multi-Path Crosstalk (dB) – is the difference in level between the output of the active path and the measured signal level in the idle path at the test signal frequency. The active path is configured and supplied with an appropriate input signal to drive a full scale output, with signal measured at the output of the specified idle path.
8. Mute Attenuation – This is a measure of the difference in level between the full scale output signal and the output with mute applied.
9. All performance measurements carried out with 20kHz low pass filter, and where noted an A-weighted filter. Failure to use such a filter will result in higher THD and lower SNR readings than are found in the Electrical Characteristics. The low pass filter removes out of band noise; although it is not audible it may affect dynamic specification values.

## TYPICAL PERFORMANCE

### TYPICAL POWER CONSUMPTION

OPERATING MODE	TEST CONDITIONS	SPKVDD (Note 3)	LDO1VDD	AVDD2	CPVDD	DBVDD (Note 4)	TOTAL
<b>Off (Battery Leakage only)</b>							
LDO1 disabled, LDO2 disabled		4.2V 0.5 $\mu$ A	4.2V 0.63 $\mu$ A	0.0V 1.0 $\mu$ A	0.0V 0.2 $\mu$ A	0.0V 2.7 $\mu$ A	0.01mW
<b>Standby</b>							
LDO1 disabled, LDO2 enabled	All supplies present, No clocks, Default register settings	4.2V 0.5 $\mu$ A	4.2V 0.63 $\mu$ A	1.8V 58.5 $\mu$ A	1.8V 0.5 $\mu$ A	1.8V 44.7 $\mu$ A	0.19mW
<b>Standby</b>							
LDO1 enabled, LDO2 enabled	All supplies present, No clocks, Default register settings	4.2V 0.5 $\mu$ A	4.2V 74.5 $\mu$ A	1.8V 58 $\mu$ A	1.8V 0.5 $\mu$ A	1.8V 56.5 $\mu$ A	0.52mW
<b>Music playback to Headphone (quiescent), Load = 32ohm</b>							
AIF1 to DAC to HPOUT1 (stereo)	fs=44.1kHz, Clocking rate=256fs, 24-bit I2S, Slave mode, Class W	4.2V 0.5 $\mu$ A	4.2V 2.27mA	1.8V 0.347mA	1.8V 0.393mA	1.8V 1.06mA	12.78mW
AIF1 to DAC to HPOUT1 (stereo) LDOs disabled, See Note 7.	fs=44.1kHz, Clocking rate=128fs, 24-bit I2S, Slave mode, Class W	3.6V 0.5 $\mu$ A	AVDD1= 2.4V 1.68mA	1.8V 0.247mA	1.8V 0.334mA	DBVDD= 1.8V 0.5 $\mu$ A DCVDD= 1.05V 0.706mA	5.82mW
<b>Music playback to Class D speaker output (quiescent), Load = 8ohm + 22<math>\mu</math>H</b>							
AIF1 to DAC to SPKOUT (stereo)	fs=44.1kHz, Clocking rate=256fs, 24-bit I2S, Slave mode, +7.5dB Class D boost	4.2V 1.76mA	4.2V 2.04mA	1.8V 1.189mA	1.8V 0.5 $\mu$ A	1.8V 1.045mA	19.15mW
AIF1 to DAC to SPKOUT (Left only)	fs=44.1kHz, Clocking rate=256fs, 24-bit I2S, Slave mode, +7.5dB Class D boost	4.2V 0.88mA	4.2V 2.04mA	1.8V 0.753mA	1.8V 0.5 $\mu$ A	1.8V 1.045mA	15.5mW

#### Notes:

1. AVDD1 = 3.0V, generated by LDO1.
2. DCVDD = 1.05V, generated by LDO2.
3. SPKVDD = SPKVDD1 = SPKVDD2.
4. DBVDD = DBVDD1 = DBVDD2 = DBVDD3.
5.  $I_{SPKVDD} = I_{SPKVDD1} + I_{SPKVDD2}$ .
6.  $I_{DBVDD} = I_{DBVDD1} + I_{DBVDD2} + I_{DBVDD3}$ .
7. Power consumption for music playback with LDOs disabled requires an external supply for AVDD1 and DCVDD

## TYPICAL SIGNAL LATENCY

OPERATING MODE	TEST CONDITIONS			LATENCY
	AIF1	AIF2	DIGITAL CORE	
<b>AIF2 to DAC Stereo Path</b>				
AIF2 EQ enabled, AIF2 3D enabled, AIF2 DRC enabled, SRC enabled	fs=8kHz, Clock rate = 256fs	fs=8kHz, Clock rate = 1536fs	SYSCLK=AIF1CLK	1.4ms
	fs=48kHz, Clock rate = 256fs	fs=8kHz, Clock rate = 1536fs	SYSCLK=AIF1CLK	1.3ms
	fs=8kHz, Clock rate = 256fs	fs=8kHz, Clock rate = 256fs	SYSCLK=AIF1CLK	1.7ms
	fs=48kHz, Clock rate = 256fs	fs=8kHz, Clock rate = 256fs	SYSCLK=AIF1CLK	1.4ms
<b>ADC to AIF2 Stereo Path</b>				
Digital Sidetone HPF enabled, AIF2 DRC enabled, AIF2 HPF enabled, SRC enabled	fs=8kHz, Clock rate = 256fs	fs=8kHz, Clock rate = 256fs	SYSCLK=AIF1CLK	2.2ms
	fs=48kHz, Clock rate = 256fs	fs=8kHz, Clock rate = 256fs	SYSCLK=AIF1CLK	1.2ms
Digital Sidetone HPF disabled, AIF2 DRC disabled, AIF2 HPF disabled, SRC disabled		fs=8kHz, Clock rate = 1536fs	SYSCLK=AIF2CLK	1.3ms
Digital Sidetone HPF disabled, AIF2 DRC disabled, AIF2 HPF disabled, SRC enabled	fs=48kHz, Clock rate = 256fs	fs=8kHz, Clock rate = 1536fs	SYSCLK=AIF1CLK	1.1ms

**Notes:**

1. These figures are relevant to typical voice call modes, assuming AIF2 is connected to the baseband processor
2. The SRC (Sample Rate Converter) is enabled automatically whenever required

## SIGNAL TIMING REQUIREMENTS

### SYSTEM CLOCKS & FREQUENCY LOCKED LOOP (FLL)

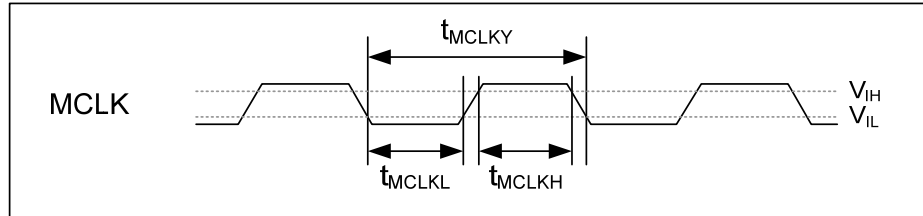

Figure 1 Master Clock Timing

#### Test Conditions

The following timing information is valid across the full range of recommended operating conditions.

PARAMETER	SYMBOL	CONDITIONS	MIN	TYP	MAX	UNIT
<b>Master Clock Timing (MCLK1 and MCLK2)</b>						
MCLK cycle time	$T_{MCLKY}$	MCLK as input to FLL, FLLn_REFCLK_DIV = 10, 11	25			ns
		MCLK as input to FLL, FLLn_REFCLK_DIV = 01	37			
		MCLK as input to FLL, FLLn_REFCLK_DIV = 00	74			
		FLL not used, AIFnCLK_DIV = 1	40			
		FLL not used, AIFnCLK_DIV = 0	80			
MCLK duty cycle (= $T_{MCLKH} : T_{MCLKL}$ )			60:40		40:60	
<b>Frequency Locked Loops (FLL1 and FLL2)</b>						
FLL Input Frequency		FLLn_REFCLK_DIV = 00	0.032		13.5	MHz
		FLLn_REFCLK_DIV = 01	0.064		27	
		FLLn_REFCLK_DIV = 10	0.128		40	
		FLLn_REFCLK_DIV = 11	0.256		40	
<b>Internal Clocking</b>						
AIF1CLK frequency					12.5	MHz
AIF2CLK frequency					12.5	MHz
SYSCLK frequency					12.5	MHz

**AUDIO INTERFACE TIMING**

**DIGITAL MICROPHONE (DMIC) INTERFACE TIMING**

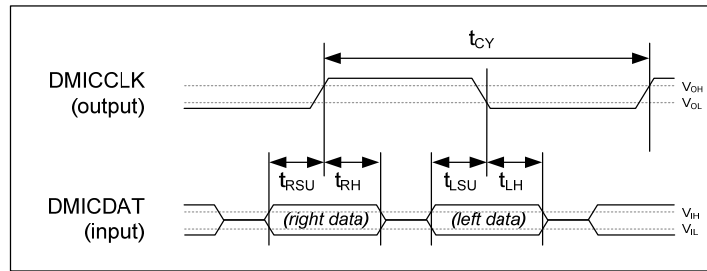

**Figure 2 Digital Microphone Interface Timing**

**Test Conditions**

The following timing information is valid across the full range of recommended operating conditions.

PARAMETER	SYMBOL	MIN	TYP	MAX	UNIT
<b>Digital Microphone Interface Timing</b>					
DMICCLK cycle time	$t_{CY}$	320			ns
DMICCLK duty cycle		45:55		55:45	
DMICDAT (Left) setup time to falling DMICCLK edge	$t_{LSU}$	15			ns
DMICDAT (Left) hold time from falling DMICCLK edge	$t_{LH}$	0			ns
DMICDAT (Right) setup time to rising DMICCLK edge	$t_{RSU}$	15			ns
DMICDAT (Right) hold time from rising DMICCLK edge	$t_{RH}$	0			ns



**DIGITAL AUDIO INTERFACE - MASTER MODE**

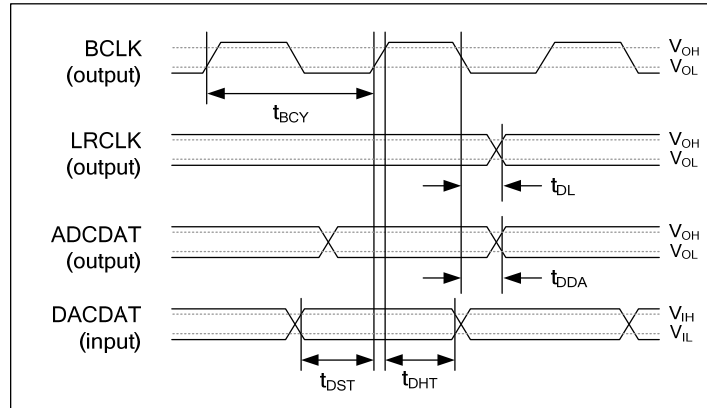

**Figure 3 Audio Interface Timing - Master Mode**

Note that BCLK and LRCLK outputs can be inverted if required; Figure 3 shows the default, non-inverted polarity of these signals.

**Test Conditions**

The following timing information is valid across the full range of recommended operating conditions.

PARAMETER	SYMBOL	MIN	TYP	MAX	UNIT
<b>Audio Interface Timing - Master Mode</b>					
BCLK cycle time	$t_{BCY}$	160			ns
LRCLK propagation delay from BCLK falling edge	$t_{DL}$			20	ns
ADCDAT propagation delay from BCLK falling edge	$t_{DDA}$			48	ns
DACDAT setup time to BCLK rising edge	$t_{DST}$	32			ns
DACDAT hold time from BCLK rising edge	$t_{DHT}$	10			ns
<b>Audio Interface Timing - Ultrasonic (4FS) Master Mode</b>					
BCLK cycle time	$t_{BCY}$	80			ns
ADCDAT propagation delay from BCLK falling edge	$t_{DDA}$			24	ns

Note that the descriptions above assume non-inverted polarity of BCLK and LRCLK.

**DIGITAL AUDIO INTERFACE - SLAVE MODE**

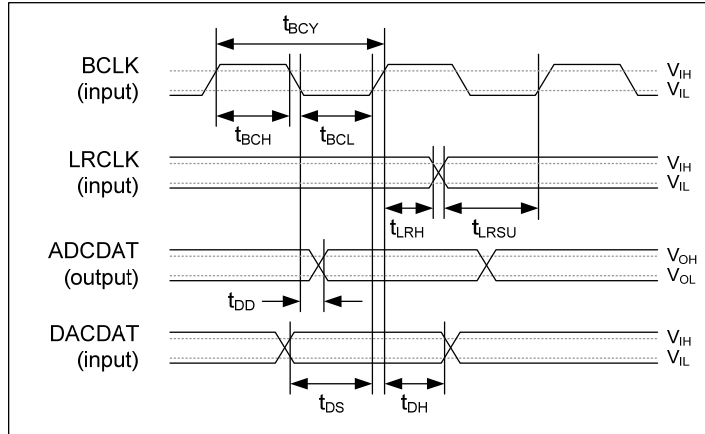

**Figure 4 Audio Interface Timing - Slave Mode**

Note that BCLK and LRCLK inputs can be inverted if required; Figure 4 shows the default, non-inverted polarity.

**Test Conditions**

The following timing information is valid across the full range of recommended operating conditions.

PARAMETER	SYMBOL	MIN	TYP	MAX	UNIT
<b>Audio Interface Timing - Slave Mode</b>					
BCLK cycle time	$t_{BCY}$	160			ns
BCLK pulse width high	$t_{BCH}$	64			ns
BCLK pulse width low	$t_{BCL}$	64			ns
LRCLK set-up time to BCLK rising edge	$t_{LRSU}$	10			ns
LRCLK hold time from BCLK rising edge	$t_{LRH}$	10			ns
DACDAT hold time from BCLK rising edge	$t_{DH}$	10			ns
ADCDAT propagation delay from BCLK falling edge	$t_{DD}$			48	ns
DACDAT set-up time to BCLK rising edge	$t_{DS}$	32			ns

Note that the descriptions above assume non-inverted polarity of BCLK and LRCLK.

**DIGITAL AUDIO INTERFACE - TDM MODE**

When TDM operation is used on the ADCDATn pins, it is important that two devices do not attempt to drive the ADCDATn pin simultaneously. To support this requirement, the ADCDATn pins can be configured to be tri-stated when not outputting data.

The timing of the ADCDATn tri-stating at the start and end of the data transmission is described in Figure 5 below.

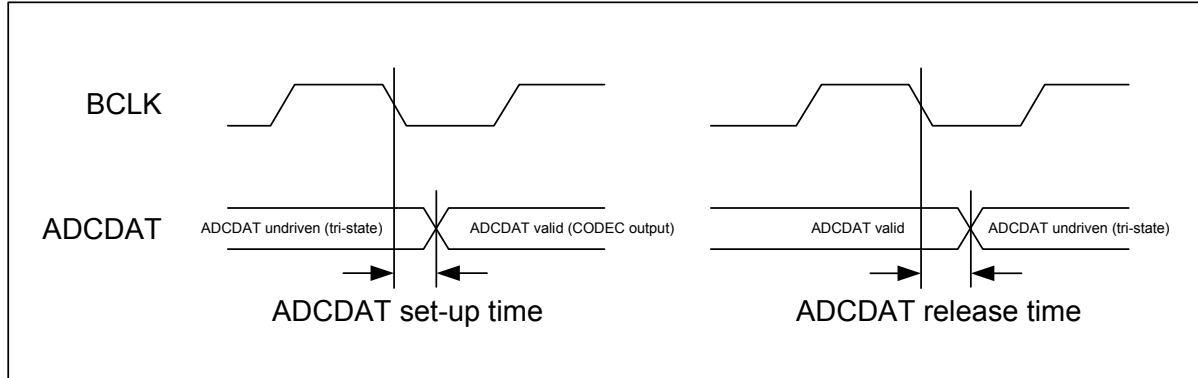

Figure 5 Audio Interface Timing- TDM Mode

**Test Conditions**

The following timing information is valid across the full range of recommended operating conditions.

PARAMETER	MIN	TYP	MAX	UNIT
<b>TDM Timing - Master Mode</b>				
ADCDATsetup time from BCLKfalling edge	0			ns
ADCDATrelease time from BCLKfalling edge			15	ns
<b>TDM Timing - Slave Mode</b>				
ADCDAT setup time from BCLK falling edge	5			ns
ADCDAT release time from BCLK falling edge			32	ns

**CONTROL INTERFACE TIMING**

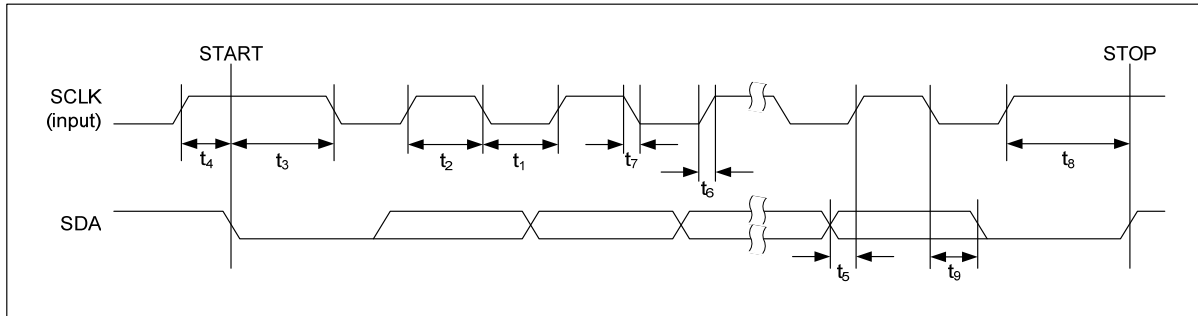

**Figure 6 Control Interface Timing**

**Test Conditions**

The following timing information is valid across the full range of recommended operating conditions.

PARAMETER	SYMBOL	MIN	TYP	MAX	UNIT
SCLK Frequency				400	kHz
SCLK Low Pulse-Width	$t_1$	1300			ns
SCLK High Pulse-Width	$t_2$	600			ns
Hold Time (Start Condition)	$t_3$	600			ns
Setup Time (Start Condition)	$t_4$	600			ns
Data Setup Time	$t_5$	100			ns
SDA, SCLK Rise Time	$t_6$			300	ns
SDA, SCLK Fall Time	$t_7$			300	ns
Setup Time (Stop Condition)	$t_8$	600			ns
Data Hold Time	$t_9$			900	ns
Pulse width of spikes that will be suppressed	$t_{ps}$	0		5	ns

## DEVICE DESCRIPTION

### INTRODUCTION

The WM1811A is a low power, high quality audio codec designed to interface with a wide range of processors and analogue components. A high level of mixed-signal integration in a very small footprint makes it ideal for portable applications such as mobile phones. Fully differential internal architecture and on-chip RF noise filters ensure a very high degree of noise immunity.

Three sets of audio interface pins are available in order to provide independent and fully asynchronous connections to multiple processors, typically an application processor, baseband processor and wireless transceiver. Any two of these interfaces can operate totally independently and asynchronously while the third interface can be synchronised to either of the other two and can also provide ultra low power loopback modes to support, for example, wireless headset voice calls.

The WM1811A provides a two-channel digital microphone interface, suitable for noise cancellation and other applications. An integrated microphone activity monitor is available to enable the processor to sleep during periods of microphone inactivity, saving power.

Eight highly flexible analogue inputs allow interfacing to up to four microphone inputs (single-ended or differential), plus multiple stereo or mono line inputs. Connections to an external voice CODEC, FM radio, line input, handset MIC and headset MIC are all fully supported. Signal routing to the output mixers and within the CODEC has been designed for maximum flexibility to support a wide variety of usage modes.

Impedance sensing and measurement for external accessories is provided, for detection of the insertion or removal of microphones and other accessories. Push-button detection of up to 7 inputs can be supported using this feature. Low power jack detection is supported, using a dedicated input pin; this enables power consumption to be minimised in standby conditions, whilst awaiting an external jack insertion event.

Nine analogue output drivers are integrated, including a stereo pair of high power, high quality Class D speaker drivers; these can support 2W each in stereo mode. It is also possible to configure the speaker drivers as a mono output, giving enhanced performance. A mono earpiece driver is provided, providing an additional output from the output mixers.

One pair of ground-referenced headphone outputs is provided; these are powered from an integrated Charge Pump, enabling high quality, power efficient headphone playback without any requirement for DC blocking capacitors. A DC Servo circuit is available for DC offset correction, thereby suppressing pops and reducing power consumption. Four line outputs are provided, with multiple configuration options including 4 x single-ended outputs or 2 x differential outputs. The line outputs are suitable for output to a voice CODEC, an external speaker driver or line output connector. Ground loop feedback is available on the headphone outputs and the line outputs, providing rejection of noise on the ground connections. All outputs have integrated pop and click suppression features.

Internal differential signal routing and amplifier configurations have been optimised to provide the highest performance and lowest possible power consumption for a wide range of usage scenarios, including voice calls and music playback. The speaker drivers offer low leakage and high PSRR; this enables direct connection to a Lithium battery. The speaker drivers provide eight levels of AC and DC gain to allow output signal levels to be maximised for many commonly-used SPKVDD/AVDD1 combinations.

The ADCs and DACs are of hi-fi quality, using a 24-bit low-order oversampling architecture to deliver optimum performance. A flexible clocking arrangement supports mixed sample rates, whilst integrated ultra-low power dual FLLs provide additional flexibility. A high pass filter is available in all ADC and digital MIC paths for removing DC offsets and suppressing low frequency noise such as mechanical vibration and wind noise. A digital mixing path from the ADC or digital MICs to the DAC provides a sidetone of enhanced quality during voice calls. DAC soft mute and un-mute is available for pop-free music playback.

The integrated Dynamic Range Controllers (DRC) and ReTune™ Mobile 5-band parametric equaliser (EQ) provide further processing capability of the digital audio paths. The DRC provides compression and signal level control to improve the handling of unpredictable signal levels. 'Anti-clip' and 'quick release' algorithms improve intelligibility in the presence of transients and impulsive noises. The EQ provides the capability to tailor the audio path according to the frequency characteristics of an earpiece or loudspeaker, and/or according to user preferences.

The WM1811A has highly flexible digital audio interfaces, supporting a number of protocols, including I<sup>2</sup>S, DSP, MSB-first left/right justified, and can operate in master or slave modes. PCM operation is supported in the DSP mode. A-law and  $\mu$ -law companding are also supported. Time division multiplexing (TDM) is available to allow multiple devices to stream data simultaneously on the same bus, saving space and power.

A powerful digital mixing core allows data from each audio interface channel and from the ADCs and digital MICs to be mixed and re-routed back to a different audio interface and to the DAC output paths. The digital mixing core can operate synchronously with either Audio Interface 1 or Audio Interface 2, with asynchronous stereo full duplex sample rate conversion performed on the other audio interface as required.

The system clock (SYSCLK) provides clocking for the ADCs, DACs, DSP core, digital audio interface and other circuits. SYSCLK can be derived directly from one of the MCLK1 or MCLK2 pins or via one of two integrated FLLs, providing flexibility to support a wide range of clocking schemes, including self-clocking FLL modes. Typical portable system MCLK frequencies, and sample rates from 8kHz to 96kHz are all supported. A low frequency (eg. 32.768kHz) clock can be used as the input reference to the FLLs, providing further flexibility. Automatic configuration of the clocking circuits is available, derived from the sample rate and from the MCLK / SYSCLK ratio.

The WM1811A uses a standard 2-wire control interface, providing full software control of all features, together with device register readback. It is an ideal partner for a wide range of industry standard microprocessors, controllers and DSPs. Unused circuitry can be disabled under software control, in order to save power; low leakage currents enable extended standby/off time in portable battery-powered applications.

Versatile GPIO functionality is provided, with support for button/accessory detect inputs, or for clock, system status, or programmable logic level output for control of additional external circuitry. Interrupt logic, status readback and de-bouncing options are supported within this functionality.

### ANALOGUE INPUT SIGNAL PATH

The WM1811A has eight highly flexible analogue input channels, configurable in a large number of combinations:

1. Up to four fully differential or single-ended microphone inputs
2. Up to eight mono line inputs or 4 stereo line inputs
3. A dedicated mono differential input from external voice CODEC

These inputs may be mixed together or independently routed to different combinations of output drivers. An internal record path is provided at the input mixers to allow DAC output to be mixed with the input signal path (e.g. for voice call recording).

The WM1811A input signal paths and control registers are illustrated in Figure 7.

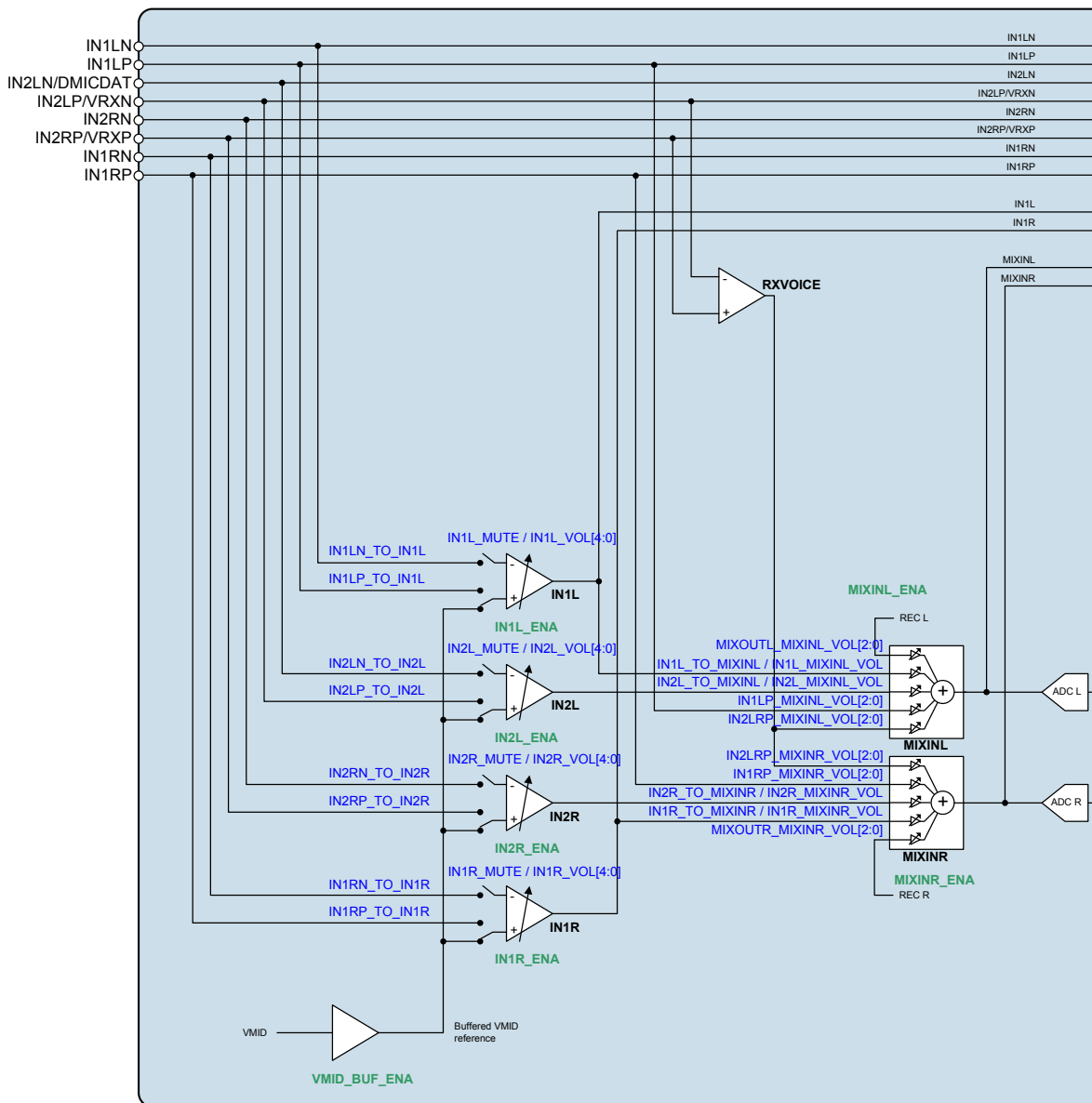

Figure 7 Control Registers for Input Signal Path

## MICROPHONE INPUTS

Up to four analogue microphones can be connected to the WM1811A, either in single-ended or differential mode. A dedicated PGA is provided for each microphone input. Two low noise microphone bias circuits are provided, reducing the need for external components.

For single-ended microphone inputs, the microphone signal is connected to the inverting input of the PGAs (IN1LN, IN2LN, IN1RN or IN2RN). The non-inverting inputs of the PGAs are internally connected to VMID in this configuration. The non-inverting input pins IN1LP, IN2LP, IN1RP and IN2RP are free to be used as line connections to the input or output mixers in this configuration.

For differential microphone inputs, the non-inverted microphone signal is connected to the non-inverting input of the PGAs (IN1LP, IN2LP, IN1RP or IN2RP), whilst the inverted (or 'noisy ground') signal is connected to the inverting input pins (IN1LN, IN2LN, IN1RN and IN2RN).

The gain of the input PGAs is controlled via register settings, as defined in Table 4. Note that the input impedance of both inverting and non-inverting inputs changes with the input PGA gain setting, as described under "Electrical Characteristics". See also the "Applications Information" for details of input resistance at all PGA Gain settings.

The microphone input configurations are illustrated in Figure 8 and Figure 9. Note that any PGA input pin that is used in either microphone configuration is not available for use as a line input path at the same time.

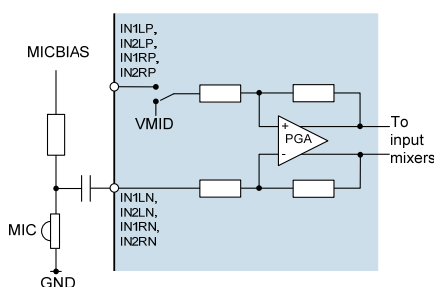

Figure 8 Single-Ended Microphone Input

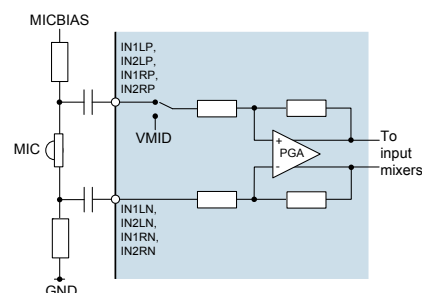

Figure 9 Differential Microphone Input

## MICROPHONE BIAS CONTROL

There are two MICBIAS generators which provide low noise reference voltages suitable for powering silicon (MEMS) microphones or biasing electret condenser (ECM) type microphones via an external resistor. Refer to the "Applications Information" section for recommended external components.

The MICBIAS outputs can be independently enabled using the MICB1\_ENA and MICB2\_ENA register bits. Under default conditions, a smooth pop-free profile of the MICBIAS outputs is implemented when MICB1\_ENA or MICB2\_ENA is enabled or disabled; a faster transition can be selected by setting the MICB1\_RATE and MICB2\_RATE registers as described in Table 1.

When a MICBIAS output is disabled, the output pin can be configured to be floating or to be actively discharged. This is selected using the MICB1\_DISCH and MICB2\_DISCH register bits.

The MICBIAS generators can each operate as a voltage regulator or in bypass mode.

In Regulator mode, the output voltage is selected using the MICB1\_LVL and MICB2\_LVL register bits. In this mode, AVDD1 must be at least 200mV greater than the required MICBIAS output voltages. The MICBIAS outputs are powered from the AVDD1 supply pin, and use the internal bandgap circuit as a reference.

Note that, in Regulator mode, the MICBIAS regulators are designed to operate without external decoupling capacitors. It is important that parasitic capacitances on the MICBIAS1 or MICBIAS2 pins do not exceed the specified limit in Regulator mode (see "Electrical Characteristics").

In Bypass mode, the output pin (MICBIAS1 or MICBIAS2) is connected directly to AVDD1. This enables a low power operating state. Note that, if a capacitive load is connected to MICBIAS1 or



MICBIAS2 (eg. for a digital microphone supply), then the respective MICBIAS generator must be configured in Bypass mode.

The MICBIAS configuration is illustrated in Figure 10.

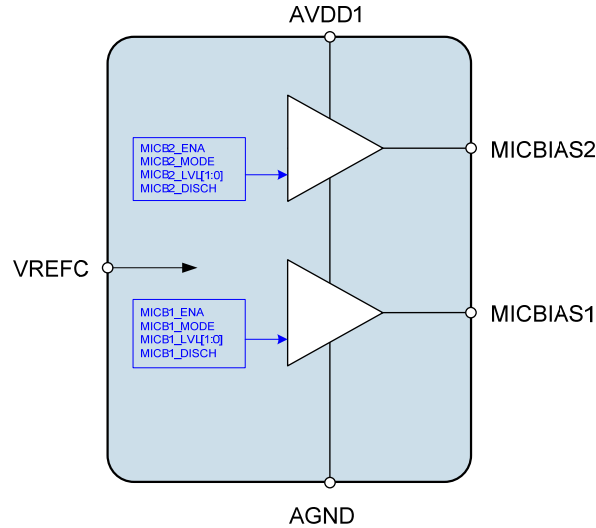

Figure 10 MICBIAS Generator

REGISTER ADDRESS	BIT	LABEL	DEFAULT	DESCRIPTION
R1 (0001h) Power Management (1)	5	MICB2_ENA	0	Microphone Bias 2 Enable 0 = Disabled 1 = Enabled
	4	MICB1_ENA	0	Microphone Bias 1 Enable 0 = Disabled 1 = Enabled
R61 (003Dh) MICBIAS 1	5	MICB1_RATE	1	Microphone Bias 1 Rate 0 = Fast start-up / shut-down 1 = Pop-free start-up / shut-down
	4	MICB1_MODE	1	Microphone Bias 1 Mode 0 = Regulator mode 1 = Bypass mode
	3:1	MICB1_LVL [2:0]	100	Microphone Bias 1 Voltage Control (when MICB1_MODE = 0) 000 = 1.5V 001 = 1.8V 010 = 1.9V 011 = 2.0V 100 = 2.2V 101 = 2.4V 110 = 2.5V 111 = 2.6V
	0	MICB1_DISCH	1	Microphone Bias 1 Discharge 0 = MICBIAS1 floating when disabled 1 = MICBIAS1 discharged when disabled
R62 (003Eh) MICBIAS	5	MICB2_RATE	1	Microphone Bias 2 Rate 0 = Fast start-up / shut-down 1 = Pop-free start-up / shut-down

REGISTER ADDRESS	BIT	LABEL	DEFAULT	DESCRIPTION
2	4	MICB2_MODE	1	Microphone Bias 2 Mode 0 = Regulator mode 1 = Bypass mode
	3:1	MICB2_LVL [2:0]	100	Microphone Bias 2 Voltage Control (when MICB2_MODE = 0) 000 = 1.5V 001 = 1.8V 010 = 1.9V 011 = 2.0V 100 = 2.2V 101 = 2.4V 110 = 2.5V 111 = 2.6V
	0	MICB2_DISCH	1	Microphone Bias 2 Discharge 0 = MICBIAS2 floating when disabled 1 = MICBIAS2 discharged when disabled

**Table 1 Microphone Bias Control**

Note that the maximum source current capability for MICBIAS1 and MICBIAS2 is 2.4mA each in Regulator mode. The external biasing resistance must be large enough to limit each MICBIAS current to 2.4mA across the full microphone impedance range. The maximum source current for MICBIAS1 and MICBIAS2 is 3.6mA each in Bypass mode, as described in the "Electrical Characteristics".

### MICROPHONE ACCESSORY DETECT

The WM1811A provides a microphone detection function, which uses impedance measurement to detect one or more different external accessory connections. This feature is described in the "External Accessory Detection" section.

### LINE AND VOICE CODEC INPUTS

All eight analogue input pins may be used as line inputs. Each line input has different signal path options, providing flexibility, high performance and low power consumption for many different usage modes.

IN1LN and IN1RN can operate as single-ended line inputs to the input PGAs IN1L and IN1R respectively. These inputs provide a high gain path if required for low input signal levels.

IN2LN and IN2RN can operate as single-ended line inputs to the input PGAs IN2L and IN2R respectively, providing further high gain signal paths. These pins can also be connected to either of the output mixers MIXOUTL and MIXOUTR.

IN1LP and IN1RP can operate as single-ended line inputs to the input mixers MIXINL and MIXINR, or to the speaker mixers SPKMIXL and SPKMIXR. These signal paths enable power consumption to be reduced, by allowing the input PGAs and other circuits to be disabled if not required.

IN2LP/VRXN and IN2RP/VRXP can operate in three different ways:

- Mono differential 'RXVOICE' input (e.g. from an external voice CODEC) to the input mixers MIXINL and MIXINR.
- Single-ended line inputs to either of the output mixers MIXOUTL and MIXOUTR.

Signal path configuration to the input PGAs and input mixers is detailed later in this section. Signal path configuration to the output mixers and speaker mixers is described in "Analogue Output Signal Path".

The line input and voice CODEC input configurations are illustrated in Figure 11 through to Figure 14.

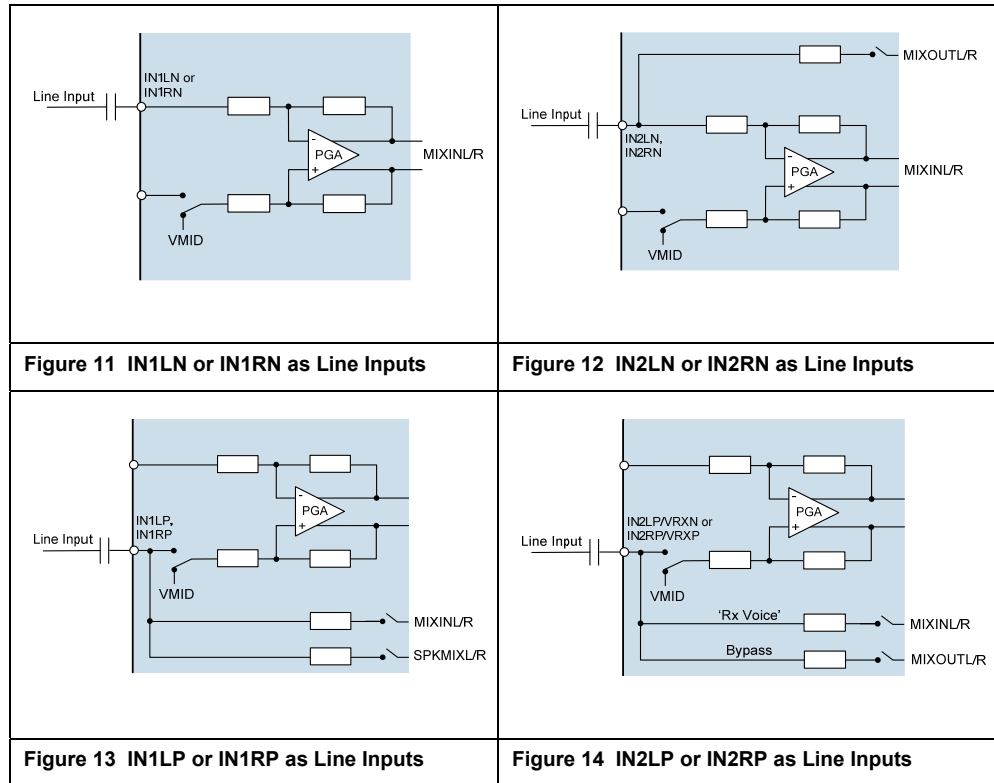

Figure 11 IN1LN or IN1RN as Line Inputs

Figure 12 IN2LN or IN2RN as Line Inputs

Figure 13 IN1LP or IN1RP as Line Inputs

Figure 14 IN2LP or IN2RP as Line Inputs

**INPUT PGA ENABLE**

The Input PGAs are enabled using register bits IN1L\_ENA, IN2L\_ENA, IN1R\_ENA and IN2R\_ENA, as described in Table 2. The Input PGAs must be enabled for microphone input on the respective input pins, or for line input on the inverting input pins IN1LN, IN1RN, IN2LN, IN2RN.

REGISTER ADDRESS	BIT	LABEL	DEFAULT	DESCRIPTION
R2 (0002h) Power Management (2)	7	IN2L_ENA	0	IN2L Input PGA Enable 0 = Disabled 1 = Enabled
	6	IN1L_ENA	0	IN1L Input PGA Enable 0 = Disabled 1 = Enabled
	5	IN2R_ENA	0	IN2R Input PGA Enable 0 = Disabled 1 = Enabled
	4	IN1R_ENA	0	IN1R Input PGA Enable 0 = Disabled 1 = Enabled

Table 2 Input PGA Enable

For normal operation of the input PGAs, the reference voltage VMID and the bias current must also be enabled. See "Reference Voltages and Master Bias" for details of the associated controls VMID\_SEL and BIAS\_ENA.

### INPUT PGA CONFIGURATION

Each of the Input PGAs can operate in a single-ended or differential mode. In differential mode, both inputs to the PGA are connected to the input source. In single-ended mode, the non-inverting input to the PGA must be connected to VMID. Configuration of the PGA inputs to the WM1811A input pins is controlled using the register bits shown in Table 3.

Single-ended microphone operation is configured by connecting the input source to the inverting input of the applicable PGA. The non-inverting input of the PGA must be connected to the buffered VMID reference. Note that the buffered VMID reference must be enabled, using the VMID\_BUF\_ENA register, as described in "Reference Voltages and Master Bias".

Differential microphone operation is configured by connecting the input source to both inputs of the applicable PGA.

Line inputs to the input pins IN1LN, IN2LN, IN1RN and IN2RN must be connected to the applicable PGA. The non-inverting input of the PGA must be connected to VMID.

Line inputs to the input pins IN1LP, IN2LP, IN1RP or IN2RP do not connect to the input PGAs. The non-inverting inputs of the associated PGAs must be connected to VMID. The inverting inputs of the associated PGAs may be used as separate mic/line inputs if required.

The maximum available attenuation on any of these input paths is achieved by using register bits shown in Table 3 to disconnect the input pins from the applicable PGA.

REGISTER ADDRESS	BIT	LABEL	DEFAULT	DESCRIPTION
R40 (0028h) Input Mixer (2)	7	IN2LP_TO_IN2L	0	IN2L PGA Non-Inverting Input Select 0 = Connected to VMID 1 = Connected to IN2LP Note that VMID_BUF_ENA must be set when using IN2L connected to VMID.
	6	IN2LN_TO_IN2L	0	IN2L PGA Inverting Input Select 0 = Not connected 1 = Connected to IN2LN
	5	IN1LP_TO_IN1L	0	IN1L PGA Non-Inverting Input Select 0 = Connected to VMID 1 = Connected to IN1LP Note that VMID_BUF_ENA must be set when using IN1L connected to VMID.
	4	IN1LN_TO_IN1L	0	IN1L PGA Inverting Input Select 0 = Not connected 1 = Connected to IN1LN
	3	IN2RP_TO_IN2R	0	IN2R PGA Non-Inverting Input Select 0 = Connected to VMID 1 = Connected to IN2RP Note that VMID_BUF_ENA must be set when using IN2R connected to VMID.
	2	IN2RN_TO_IN2R	0	IN2R PGA Inverting Input Select 0 = Not connected 1 = Connected to IN2RN
	1	IN1RP_TO_IN1R	0	IN1R PGA Non-Inverting Input Select 0 = Connected to VMID 1 = Connected to IN1RP Note that VMID_BUF_ENA must be set when using IN1R connected to VMID.
	0	IN1RN_TO_IN1R	0	IN1R PGA Inverting Input Select 0 = Not connected 1 = Connected to IN1RN

Table 3 Input PGA Configuration

### INPUT PGA VOLUME CONTROL

Each of the four Input PGAs has an independently controlled gain range of -16.5dB to +30dB in 1.5dB steps. The gains on the inverting and non-inverting inputs to the PGAs are always equal. Each Input PGA can be independently muted using the PGA mute bits as described in Table 4, with maximum mute attenuation achieved by simultaneously disconnecting the corresponding inputs described in Table 3.

Note that, under default conditions (following power-up or software reset), the PGA mute register bits are set to '1', but the mute functions will only become effective after the respective bit has been toggled to '0' and then back to '1'. The Input PGAs will be un-muted (Mute disabled) after power-up or software reset, regardless of the readback value of the respective PGA mute bits.

To prevent "zipper noise", a zero-cross function is provided on the input PGAs. When this feature is enabled, volume updates will not take place until a zero-crossing is detected. In the case of a long period without zero-crossings, a timeout function is provided. When the zero-cross function is enabled, the volume will update after the timeout period if no earlier zero-cross has occurred. The timeout clock is enabled using TOCLK\_ENA, the timeout period is set by TOCLK\_DIV. See "Clocking and Sample Rates" for more information on these fields.

The IN1\_VU and IN2\_VU bits control the loading of the input PGA volume data. When IN1\_VU and IN2\_VU are set to 0, the PGA volume data will be loaded into the respective control register, but will not actually change the gain setting. The IN1L and IN1R volume settings are both updated when a 1 is written to IN1\_VU; the IN2L and IN2R volume settings are both updated when a 1 is written to IN2\_VU. This makes it possible to update the gain of the left and right signal paths simultaneously.

The Input PGA Volume Control register fields are described in Table 4 and Table 5.

REGISTER ADDRESS	BIT	LABEL	DEFAULT	DESCRIPTION
R24 (0018h) Left Line Input 1&2 Volume	8	IN1_VU	N/A	Input PGA Volume Update Writing a 1 to this bit will cause IN1L and IN1R input PGA volumes to be updated simultaneously
	7	IN1L_MUTE	1	IN1L PGA Mute 0 = Disable Mute 1 = Enable Mute
	6	IN1L_ZC	0	IN1L PGA Zero Cross Detector 0 = Change gain immediately 1 = Change gain on zero cross only
	4:0	IN1L_VOL [4:0]	01011 (0dB)	IN1L Volume -16.5dB to +30dB in 1.5dB steps (See Table 5 for volume range)

REGISTER ADDRESS	BIT	LABEL	DEFAULT	DESCRIPTION
R25 (0019h) Left Line Input 3&4 Volume	8	IN2_VU	N/A	Input PGA Volume Update Writing a 1 to this bit will cause IN2L and IN2R input PGA volumes to be updated simultaneously
	7	IN2L_MUTE	1	IN2L PGA Mute 0 = Disable Mute 1 = Enable Mute
	6	IN2L_ZC	0	IN2L PGA Zero Cross Detector 0 = Change gain immediately 1 = Change gain on zero cross only
	4:0	IN2L_VOL[4:0]	01011 (0dB)	IN2L Volume -16.5dB to +30dB in 1.5dB steps (See Table 5 for volume range)
R26 (001Ah) Right Line Input 1&2 Volume	8	IN1_VU	N/A	Input PGA Volume Update Writing a 1 to this bit will cause IN1L and IN1R input PGA volumes to be updated simultaneously
	7	IN1R_MUTE	1	IN1R PGA Mute 0 = Disable Mute 1 = Enable Mute
	6	IN1R_ZC	0	IN1R PGA Zero Cross Detector 0 = Change gain immediately 1 = Change gain on zero cross only
	4:0	IN1R_VOL[4:0]	01011 (0dB)	IN1R Volume -16.5dB to +30dB in 1.5dB steps (See Table 5 for volume range)
R27 (001Bh) Right Line Input 3&4 Volume	8	IN2_VU	N/A	Input PGA Volume Update Writing a 1 to this bit will cause IN2L and IN2R input PGA volumes to be updated simultaneously
	7	IN2R_MUTE	1	IN2R PGA Mute 0 = Disable Mute 1 = Enable Mute
	6	IN2R_ZC	0	IN2R PGA Zero Cross Detector 0 = Change gain immediately 1 = Change gain on zero cross only
	4:0	IN2R_VOL[4:0]	01011 (0dB)	IN2R Volume -16.5dB to +30dB in 1.5dB steps (See Table 5 for volume range)

Table 4 Input PGA Volume Control

IN1L_VOL[4:0], IN2L_VOL[4:0], IN1R_VOL[4:0], IN2R_VOL[4:0]	VOLUME (dB)
00000	-16.5
00001	-15.0
00010	-13.5
00011	-12.0
00100	-10.5
00101	-9.0
00110	-7.5
00111	-6.0
01000	-4.5
01001	-3.0
01010	-1.5
01011	0
01100	+1.5
01101	+3.0
01110	+4.5
01111	+6.0
10000	+7.5
10001	+9.0
10010	+10.5
10011	+12.0
10100	+13.5
10101	+15.0
10110	+16.5
10111	+18.0
11000	+19.5
11001	+21.0
11010	+22.5
11011	+24.0
11100	+25.5
11101	+27.0
11110	+28.5
11111	+30.0

Table 5 Input PGA Volume Range



### INPUT MIXER ENABLE

The WM1811A has two analogue input mixers which allow the Input PGAs and Line Inputs to be combined in a number of ways and output to the ADCs, Output Mixers, or directly to the output drivers via bypass paths.

The input mixers MIXINL and MIXINR are enabled by the MIXINL\_ENA and MIXINR\_ENA register bits, as described in Table 6. These control bits also enable the RXVOICE input path, described in the following section.

For normal operation of the input mixers, the reference voltage VMID and the bias current must also be enabled. See "Reference Voltages and Master Bias" for details of the associated controls VMID\_SEL and BIAS\_ENA.

REGISTER ADDRESS	BIT	LABEL	DEFAULT	DESCRIPTION
R2 (0002h) Power Management (2)	9	MIXINL_ENA	0	Left Input Mixer Enable (Enables MIXINL and RXVOICE input to MIXINL) 0 = Disabled 1 = Enabled
	8	MIXINR_ENA	0	Right Input Mixer Enable (Enables MIXINR and RXVOICE input to MIXINR) 0 = Disabled 1 = Enabled

**Table 6 Input Mixer Enable**

### INPUT MIXER CONFIGURATION AND VOLUME CONTROL

The left and right channel input mixers MIXINL and MIXINR can be configured to take input from up to five sources:

1. IN1L or IN1R Input PGA
2. IN2L or IN2R Input PGA
3. IN1LP or IN1RP pin (PGA bypass)
4. RXVOICE mono differential input from IN2LP/VRXN and IN2RP/VRXP
5. MIXOUTL or MIXOUTR Output Mixer (Record path)

The Input Mixer configuration and volume controls are described in Table 7 for the Left input mixer (MIXINL) and Table 8 for the Right input mixer (MIXINR). The signal levels from the Input PGAs may be set to Mute, 0dB or 30dB boost. Gain controls for the PGA bypass, RXVOICE and Record paths provide adjustment from -12dB to +6dB in 3dB steps.

When using the IN1LP or IN1RP signal paths direct to the input mixers (PGA bypass paths), a signal gain of +15dB can be selected using the IN1RP\_MIXINR\_BOOST or IN1LP\_MIXINL\_BOOST register bits. See Table 7 and Table 8 for further details.

When using the IN1LP or IN1RP signal paths direct to the input mixers (PGA bypass paths), the buffered VMID reference must be enabled, using the VMID\_BUF\_ENA register, as described in "Reference Voltages and Master Bias".

To prevent pop noise, it is recommended that gain and mute controls for the input mixers are not modified while the signal paths are active. If volume control is required on these signal paths, it is recommended that this is implemented using the input PGA volume controls or the ADC volume controls. The ADC volume controls are described in the "Analogue to Digital Converter (ADC)" section.

REGISTER ADDRESS	BIT	LABEL	DEFAULT	DESCRIPTION
R21 (0015h) Input Mixer (1)	7	IN1LP_MIXINL_BOOST	0	IN1LP Pin (PGA Bypass) to MIXINL Gain Boost. This bit selects the maximum gain setting of the IN1LP_MIXINL_VOL register. 0 = Maximum gain is +6dB 1 = Maximum gain is +15dB
R41 (0029h) Input Mixer (3)	8	IN2L_TO_MIXINL	0	IN2L PGA Output to MIXINL Mute 0 = Mute 1 = Un-Mute
	7	IN2L_MIXINL_VOL	0	IN2L PGA Output to MIXINL Gain 0 = 0dB 1 = +30dB
	5	IN1L_TO_MIXINL	0	IN1L PGA Output to MIXINL Mute 0 = Mute 1 = Un-Mute
	4	IN1L_MIXINL_VOL	0	IN1L PGA Output to MIXINL Gain 0 = 0dB 1 = +30dB
	2:0	MIXOUTL_MIXINL_VOL [2:0]	000 (Mute)	Record Path MIXOUTL to MIXINL Gain and Mute 000 = Mute 001 = -12dB 010 = -9dB 011 = -6dB 100 = -3dB 101 = 0dB 110 = +3dB 111 = +6dB
R43 (002Bh) Input Mixer (5)	8:6	IN1LP_MIXINL_VOL [2:0]	000 (Mute)	IN1LP Pin (PGA Bypass) to MIXINL Gain and Mute 000 = Mute 001 = -12dB 010 = -9dB 011 = -6dB 100 = -3dB 101 = 0dB 110 = +3dB 111 = +6dB (see note below). When IN1LP_MIXINL_BOOST is set, then the maximum gain setting is increased to +15dB, ie. 111 = +15dB. Note that VMID_BUF_ENA must be set when using the IN1LP (PGA Bypass) input to MIXINL.

REGISTER ADDRESS	BIT	LABEL	DEFAULT	DESCRIPTION
	2:0	IN2LRP_MIXINL_VOL [2:0]	000 (Mute)	RXVOICE Differential Input (VRXP-VRXN) to MIXINL Gain and Mute 000 = Mute 001 = -12dB 010 = -9dB 011 = -6dB 100 = -3dB 101 = 0dB 110 = +3dB 111 = +6dB

Table 7 Left Input Mixer (MIXINL) Volume Control

REGISTER ADDRESS	BIT	LABEL	DEFAULT	DESCRIPTION
R21 (0015h) Input Mixer (1)	8	IN1RP_MIXINR_BOOST	0	IN1RP Pin (PGA Bypass) to MIXINR Gain Boost. This bit selects the maximum gain setting of the IN1RP_MIXINR_VOL register. 0 = Maximum gain is +6dB 1 = Maximum gain is +15dB
R42 (002A) Input Mixer (4)	8	IN2R_TO_MIXINR	0	IN2R PGA Output to MIXINR Mute 0 = Mute 1 = Un-Mute
	7	IN2R_MIXINR_VOL	0	IN2R PGA Output to MIXINR Gain 0 = 0dB 1 = +30dB
	5	IN1R_TO_MIXINR	0	IN1R PGA Output to MIXINR Mute 0 = Mute 1 = Un-Mute
	4	IN1R_MIXINR_VOL	0	IN1R PGA Output to MIXINR Gain 0 = 0dB 1 = +30dB
	2:0	MIXOUTR_MIXINR_VOL [2:0]	000 (Mute)	Record Path MIXOUTR to MIXINR Gain and Mute 000 = Mute 001 = -12dB 010 = -9dB 011 = -6dB 100 = -3dB 101 = 0dB 110 = +3dB 111 = +6dB

REGISTER ADDRESS	BIT	LABEL	DEFAULT	DESCRIPTION
R44 (002Ch) Input Mixer (6)	8:6	IN1RP_MIXINR_VOL [2:0]	000 (Mute)	IN1RP Pin (PGA Bypass) to MIXINR Gain and Mute 000 = Mute 001 = -12dB 010 = -9dB 011 = -6dB 100 = -3dB 101 = 0dB 110 = +3dB 111 = +6dB (see note below). When IN1RP_MIXINR_BOOST is set, then the maximum gain setting is increased to +15dB, ie. 111 = +15dB. Note that VMID_BUF_ENA must be set when using the IN1RP (PGA Bypass) input to MIXINR.
	2:0	IN2LRP_MIXINR_VOL [2:0]	000 (Mute)	RXVOICE Differential Input (VRXP-VRXN) to MIXINR Gain and Mute 000 = Mute 001 = -12dB 010 = -9dB 011 = -6dB 100 = -3dB 101 = 0dB 110 = +3dB 111 = +6dB

Table 8 Right Input Mixer (MIXINR) Volume Control

## DIGITAL MICROPHONE INTERFACE

The WM1811A supports a stereo digital microphone interface. Two channels of audio data are multiplexed on the DMICDAT pin; the data is clocked using the DMICCLK output pin.

The DMICDAT function is shared with the IN2LN pin; the analogue signal paths from IN2LN cannot be used when this pin is used for DMICDAT digital microphone input.

The digital microphone interface is referenced to the MICBIAS1 voltage domain; the MICBIAS1 output must be enabled (MICB1\_ENA = 1) when using the digital microphone interface.

The MICBIAS1 generator is suitable for use as a low noise supply for the digital microphones. Note that, if the capacitive load on the MICBIAS1 generator exceeds the specified limit (eg. due to a decoupling capacitor or long PCB trace), then the MICBIAS1 generator must be configured in Bypass mode. See "Analogue Input Signal Path" for details of the MICBIAS1 generator.

When digital microphone input is enabled, the WM1811A outputs a clock signal on the DMICCLK pin.

A pair of digital microphones is connected as illustrated in Figure 15. The microphones must be configured to ensure that the Left mic transmits a data bit when DMICCLK is high, and the Right mic transmits a data bit when DMICCLK is low. The WM1811A samples the digital microphone data at the end of each DMICCLK phase. Each microphone must tri-state its data output when the other microphone is transmitting.

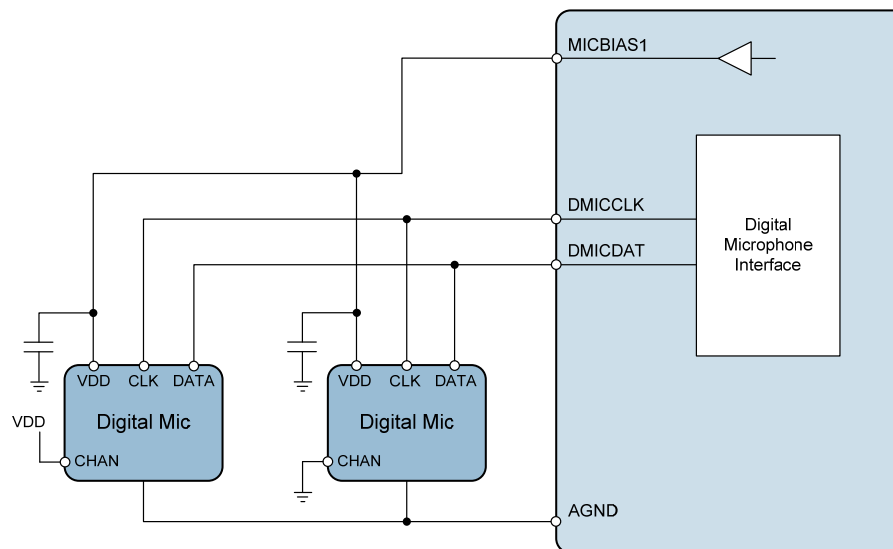

**Figure 15 Digital Microphone Input**

The DMICDAT digital microphone channels are enabled using DMIC1L\_ENA and DMIC1R\_ENA. When these signal paths are enabled, the respective ADC path is disconnected and the digital microphone data is routed to the digital mixing input bus, as illustrated in "Digital Mixing".

Two microphone channels are interleaved on DMICDAT; the timing is illustrated in Figure 16. Each microphone must tri-state its data output when the other microphone is transmitting.

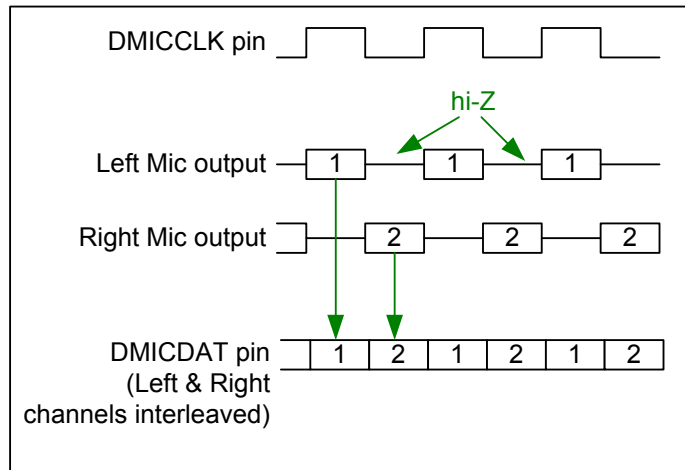

**Figure 16 Digital Microphone Interface Timing**

The digital microphone channels can be routed to the AIF1 digital audio interface output paths.

Digital volume control of the digital microphone channels in the AIF1 signal paths is provided using the registers described in the “Digital Volume and Filter Control” section.

The digital microphone channels can also be routed, in a limited number of configurations, to the digital mixing output bus, via the digital sidetone signal paths. See “Digital Mixing” for further details.

Digital volume control of the digital microphone channels in the digital sidetone signal paths is provided using the registers described in the “Digital Mixing” section.

The digital microphone interface control fields are described in Table 9.

REGISTER ADDRESS	BIT	LABEL	DEFAULT	DESCRIPTION
R4 (0004h) Power Management (4)	3	DMIC1L_ENA	0	Digital microphone (DMICDAT) Left channel enable 0 = Disabled 1 = Enabled
	2	DMIC1R_ENA	0	Digital microphone (DMICDAT) Right channel enable 0 = Disabled 1 = Enabled

**Table 9 Digital Microphone Interface Control**

Clocking for the Digital Microphone interface is derived from SYSCLK. The DMICCLK frequency is configured automatically, according to the AIFn\_SR, AIFnCLK\_RATE and ADC\_OSR128 registers. (See "Clocking and Sample Rates" for further details of the system clocks and control registers.)

The DMICCLK is enabled whenever a digital microphone input path is enabled on the DMICDATpin. Note that the SYSDSPCLK\_ENA register must also be set.

When AIF1CLK is selected as the SYSCLK source (SYSCLK\_SRC = 0), then the DMICCLK frequency is controlled by the AIF1\_SR and AIF1CLK\_RATE registers.

When AIF2CLK is selected as the SYSCLK source (SYSCLK\_SRC = 1), then the DMICCLK frequency is controlled by the AIF2\_SR and AIF2CLK\_RATE registers.

The DMICCLK frequency is as described in Table 10 (for ADC\_OSR128=1) and Table 11 (for ADC\_OSR128=0). The ADC\_OSR128 bit is set by default, giving best audio performance. Note that the only valid DMICCLK configurations are the ones listed in Table 10 and Table 11.

The applicable clocks (SYSCLK, and AIF1CLK or AIF2CLK) must be present and enabled when using the digital microphone interface.

SAMPLE RATE (kHz)	SYSCLK RATE (AIFnCLK / fs ratio)							
	128	192	256	384	512	768	1024	1536
8					2.048		2.048	2.048
11.025					2.8224		2.8224	
12					3.072		3.072	
16			2.048		2.048	2.048		
22.05			2.8224		2.8224			
24			3.072		3.072			
32			2.048					
44.1			2.8224					
48			3.072					
88.2								
96								

Note that, when ADC\_OSR128=1, digital microphone operation is only supported for the above DMICCLK configurations.

**Table 10 DMICCLK Frequency (MHz) - ADC\_OSR128 = 1 (Default)**

SAMPLE RATE (kHz)	SYSCLK RATE (AIFnCLK / fs ratio)							
	128	192	256	384	512	768	1024	1536
8			1.024		1.024	1.024	1.024	1.024
11.025			1.4112		1.4112	1.4112	1.4112	
12			1.536		1.536	1.536	1.536	
16			1.024	1.024	1.024	1.024		
22.05			1.4112	1.4112	1.4112			
24			1.536	1.536	1.536			
32			2.048	2.048				
44.1			2.8224					
48			3.072					
88.2								
96								

Note that, when ADC\_OSR128=0, digital microphone operation is only supported for the above DMICCLK configurations.

**Table 11 DMICCLK Frequency (MHz) - ADC\_OSR128 = 0**

### DIGITAL PULL-UP AND PULL-DOWN

The WM1811A provides integrated pull-up and pull-down resistors on the DMICDAT pin. This provides a flexible capability for interfacing with other devices. Each of the pull-up and pull-down resistors can be configured independently using the register bits described in Table 12.

Note that, if the DMICDAT digital microphone channels are disabled, or if DMICDAT1\_PU and DMICDAT1\_PD are both set, then the pull-up and pull-down will be disabled.

REGISTER ADDRESS	BIT	LABEL	DEFAULT	DESCRIPTION
R1824 (0720h) Pull Control (1)	9	DMICDAT1_PU	0	DMICDAT Pull-Up enable 0 = Disabled 1 = Enabled
	8	DMICDAT1_PD	0	DMICDAT Pull-Down enable 0 = Disabled 1 = Enabled

**Table 12 Digital Pull-Up and Pull-Down Control**

### ANALOGUE TO DIGITAL CONVERTER (ADC)

The WM1811A uses stereo 24-bit sigma-delta ADCs. The use of multi-bit feedback and high oversampling rates reduces the effects of jitter and high frequency noise. The oversample rate can be adjusted, if required, to reduce power consumption - see "Clocking and Sample Rates" for details. The ADC full scale input level is proportional to AVDD1 - see "Electrical Characteristics". Any input signal greater than full scale may overload the ADC and cause distortion.

The ADCs are enabled by the ADCL\_ENA and ADCR\_ENA register bits.

REGISTER ADDRESS	BIT	LABEL	DEFAULT	DESCRIPTION
R4 (0004h) Power Management (4)	1	ADCL_ENA	0	Left ADC Enable 0 = Disabled 1 = Enabled
	0	ADCR_ENA	0	Right ADC Enable 0 = Disabled 1 = Enabled

**Table 13 ADC Enable Control**

The outputs of the ADCs can be routed to the AIF1 digital audio interface output paths.

Digital volume control of the ADC outputs in the AIF1 signal paths is provided using the registers described in the "Digital Volume and Filter Control" section.

The outputs of the ADCs can also be routed, in a limited number of configurations, to the digital mixing output bus, via the digital sidetone signal paths. See "Digital Mixing" for further details.

Digital volume control of the ADC outputs in the digital sidetone signal paths is provided using the registers described in the "Digital Mixing" section.



**ADC CLOCKING CONTROL**

Clocking for the ADCs is derived from SYSCLK. The required clock is enabled when the SYSDSPCLK\_ENA register is set.

The ADC clock rate is configured automatically, according to the AIFn\_SR, AIFnCLK\_RATE and ADC\_OSR128 registers. (See "Clocking and Sample Rates" for further details of the system clocks and control registers.)

When AIF1CLK is selected as the SYSCLK source (SYSCLK\_SRC = 0), then the ADC clocking is controlled by the AIF1\_SR and AIF1CLK\_RATE registers.

When AIF2CLK is selected as the SYSCLK source (SYSCLK\_SRC = 1), then the ADC clocking is controlled by the AIF2\_SR and AIF2CLK\_RATE registers.

The supported ADC clocking configurations are described in Table 14 (for ADC\_OSR128=1) and Table 15 (for ADC\_OSR128=0). The ADC\_OSR128 bit is set by default, giving best audio performance.

SAMPLE RATE (kHz)	SYSCLK RATE (AIFnCLK / fs ratio)							
	128	192	256	384	512	768	1024	1536
8					✓		✓	✓
11.025					✓		✓	
12					✓		✓	
16			✓	✓	✓	✓		
22.05			✓	✓	✓			
24			✓	✓	✓			
32			✓	✓				
44.1			✓					
48			✓					
88.2								
96								

When ADC\_OSR128=1, ADC operation is only supported for the configurations indicated above

**Table 14 ADC Clocking - ADC\_OSR128 = 1 (Default)**

SAMPLE RATE (kHz)	SYSCLK RATE (AIFnCLK / fs ratio)							
	128	192	256	384	512	768	1024	1536
8			✓	✓	✓	✓	✓	✓
11.025			✓	✓	✓	✓	✓	
12			✓	✓	✓	✓	✓	
16			✓	✓	✓	✓		
22.05			✓	✓	✓			
24			✓	✓	✓			
32			✓	✓				
44.1			✓					
48			✓					
88.2								
96								

When ADC\_OSR128=0, ADC operation is only supported for the configurations indicated above

**Table 15 ADC Clocking - ADC\_OSR128 = 0**

The clocking requirements in Table 14 and Table 15 are only applicable to the AIFnCLK that is selected as the SYSCLK source. Note that both clocks (AIF1CLK and AIF2CLK) must satisfy the requirements noted in the "Clocking and Sample Rates" section.

The applicable clocks (SYSCLK, and AIF1CLK or AIF2CLK) must be present and enabled when using the Analogue to Digital Converters (ADCs).

## DIGITAL CORE ARCHITECTURE

The WM1811A Digital Core provides an extensive set of mixing and signal processing features. The Digital Core Architecture is illustrated in Figure 17, which also identifies the datasheet sections applicable to each portion of the Digital Core.

The digital audio interfaces AIF1 and AIF2 each support one stereo pair of input and output signal paths through the WM1811A DSP functions. The signal mixing for the AIF1 and AIF2 output paths is described in “Audio Interface 1 (AIF1) Output Digital Mixing” and “Audio Interface 2 (AIF2) Output Digital Mixing” respectively.

A digital mixing path from the ADCs or Digital Microphones to the DAC and AIF2 output paths provides a high quality sidetone for voice calls or other applications. The sidetone filter and volume controls are described in “Digital Sidetone Volume and Filter Control”.

Each of the DACs has a dedicated mixer for controlling the signal paths to that DAC. The configuration of these signal paths is described in “DAC Output Digital Mixing”. A similar pair of mixers is provided for controlling the signal paths to the AIF2 output channels, as described in “Audio Interface 2 (AIF2) Output Digital Mixing”.

The DAC and AIF2 output signal paths are each provided with digital volume control and soft mute / un-mute features. The associated controls are defined in the “Digital Volume (DAC and AIF2 Output Paths)” and the “Digital Volume Soft Mute and Soft Un-Mute” sections.

Digital signal processing can be applied to the input and output signal paths. The available features include 5-band equalization (EQ), 3D stereo expansion and dynamic range control (DRC).

The EQ provides the capability to tailor the audio path according to the frequency characteristics of an earpiece or loudspeaker, and/or according to user preferences. The EQ controls are described in “ReTune™ Mobile Parametric Equalizer (EQ)”. The DRC provides adaptive signal level control to improve the handling of unpredictable signal levels and to improve intelligibility in the presence of transients and impulsive noises. The DRC controls are described in “Dynamic Range Control (DRC)”. 3D stereo expansion provides a stereo enhancement effect; the depth of the effect is programmable, as described in “3D Stereo Expansion”.

The input signal paths are also equipped with digital volume control and soft mute / un-mute control; see “Digital Volume and Filter Control” for details of these features.

The output signal paths are equipped with digital volume control and a programmable high-pass filter (HPF). The Dynamic Range Control (DRC) circuit can also be applied here, with the restriction that a DRC cannot be enabled in the input and output path of one AIF channel at the same time. The AIF output volume and filter controls are described in “Digital Volume and Filter Control”.

The WM1811A provides an ultrasonic mode on the output paths of AIF1, allowing high frequency signals (such as ultrasonic microphone signals) to be output. See “Ultrasonic (4FS) AIF Output Mode” for further details.

The WM1811A provides two full audio interfaces, AIF1 and AIF2. Each interface supports a number of protocols, including I<sup>2</sup>S, DSP, MSB-first left/right justified, and can operate in master or slave modes. PCM operation is supported in the DSP mode. A-law and  $\mu$ -law companding are also supported. Time division multiplexing (TDM) is available to allow multiple devices to stream data simultaneously on the same bus, saving space and power.

Two-channel input and output is supported on AIF1 and on AIF2. A third interface, AIF3, is partially supported, using multiplexers to re-configure alternate connections to AIF1 or AIF2.

Signal mixing between audio interfaces is possible. The WM1811A performs stereo full-duplex sample rate conversion between the audio interfaces as required.

The audio interfaces AIF1, AIF2 and AIF3 are referenced to DBVDD1, DBVDD2 and DBVDD3 respectively; this provides additional capability to interface between different sub-systems within an application.

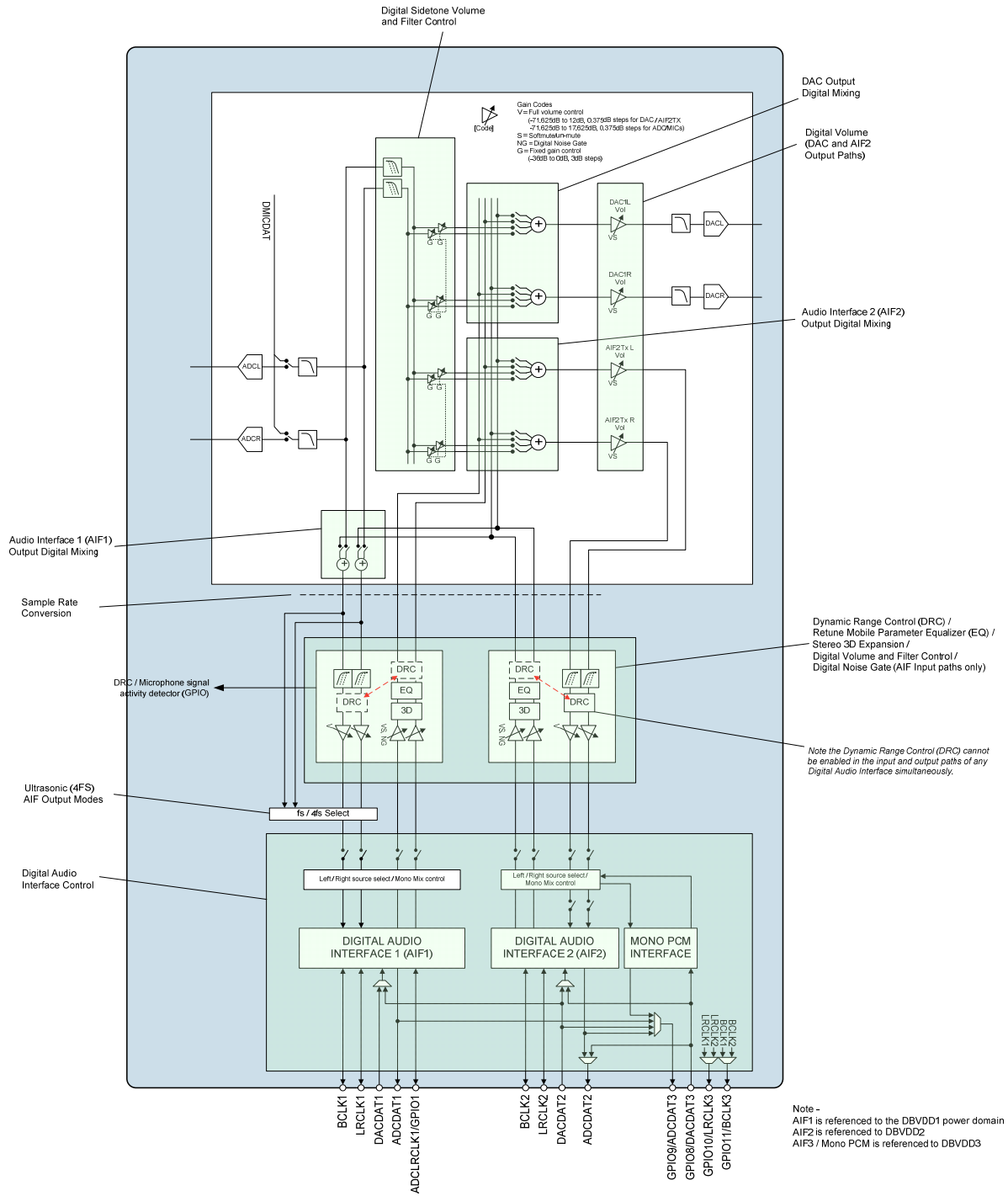

Figure 17 Digital Core Architecture

DIGITAL MIXING

This section describes the digital mixing functions of the WM1811A.

Digital audio mixing is provided on the AIF1 output, digital sidetone, Digital to Analogue converters(DACs) and AIF2 output paths.

The digital mixing functions and associated control registers are illustrated in Figure 18.

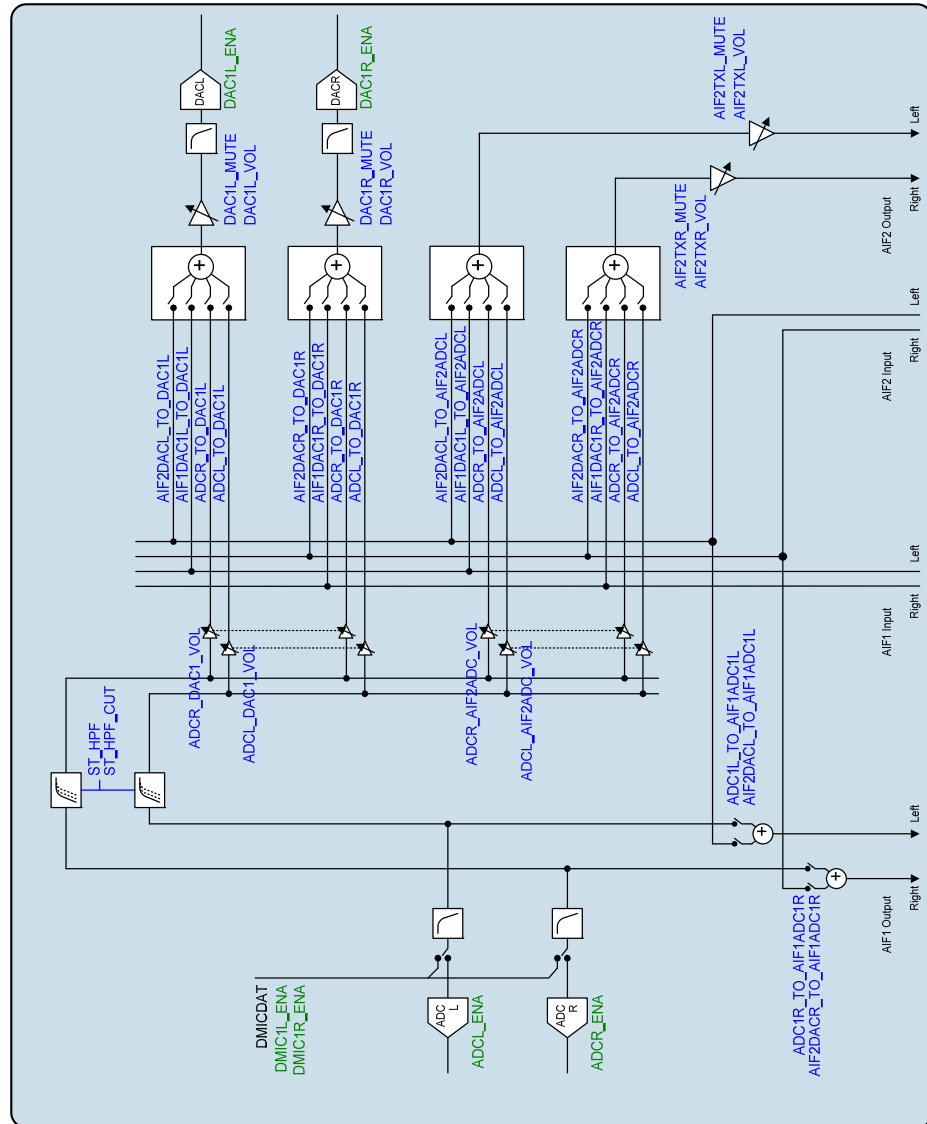

Figure 18 Digital Mixing Block Diagram

### AUDIO INTERFACE 1 (AIF1) OUTPUT DIGITAL MIXING

There are two digital mixers associated with the AIF1 output channels. The inputs to each AIF1 mixer comprise signals from the ADC / Digital Microphone inputs and from AIF2.

Note that the Left/Right channels of AIF1 can be inverted or interchanged if required; see “Digital Audio Interface Control”.

The AIF1 Left output channel is derived from the ADCL / DMIC (Left) and AIF2 (Left) inputs. The ADCL / DMIC (Left) path is enabled by ADC1L\_TO\_AIF1ADC1L, whilst the AIF2 (Left) path is enabled by AIF2DACL\_TO\_AIF1ADC1L.

The AIF1 Right output channel is derived from the ADCR / DMIC (Right) and AIF2 (Right) inputs. The ADCR / DMIC (Right) path is enabled by ADC1R\_TO\_AIF1ADC1R, whilst the AIF2 (Right) path is enabled by AIF2DACR\_TO\_AIF1ADC1R.

The AIF1 output mixer controls are defined in Table 16.

REGISTER ADDRESS	BIT	LABEL	DEFAULT	DESCRIPTION
R1542 (0606h) AIF1 ADC1 Left Mixer Routing	1	ADC1L_TO_AIF1ADC1L	0	Enable ADCL / DMIC (Left) to AIF1 (Left) output 0 = Disabled 1 = Enabled
	0	AIF2DACL_TO_AIF1ADC1L	0	Enable AIF2 (Left) to AIF1 (Left) output 0 = Disabled 1 = Enabled
R1543 (0607h) AIF1 ADC1 Right Mixer Routing	1	ADC1R_TO_AIF1ADC1R	0	Enable ADCR / DMIC (Right) to AIF1 (Right) output 0 = Disabled 1 = Enabled
	0	AIF2DACR_TO_AIF1ADC1R	0	Enable AIF2 (Right) to AIF1 (Right) output 0 = Disabled 1 = Enabled

**Table 16 AIF1 Output Mixing**

### DIGITAL SIDETONE VOLUME AND FILTER CONTROL

There are two digital sidetone signal paths, STL and STR.

The STL source is either ADCL or DMICDAT (Left). The Left ADC data will be selected if the corresponding ADC is enabled (ie. if ADCL\_ENA = 1). The Left digital microphone (DMIC) data will be selected if the corresponding ADC is disabled (ie. if ADCL\_ENA = 0).

The STR source is either ADCR or DMICDAT (Right). The Right ADC data will be selected if the corresponding ADC is enabled (ie. if ADCR\_ENA = 1). The Right digital microphone (DMIC) data will be selected if the corresponding ADC is disabled (ie. if ADCR\_ENA = 0).

See “Analogue to Digital Converter (ADC)” for details of the ADC control registers.

A digital volume control is provided for the digital sidetone paths. The associated register controls are described in Table 17.

A digital high-pass filter can be enabled in the sidetone paths to remove DC offsets. This filter is enabled using the ST\_HPF register bit; the cut-off frequency is configured using ST\_HPF\_CUT. When the filter is enabled, it is enabled in both digital sidetone paths.

Note that the sidetone filter cut-off frequency scales according to the sample rate of AIF1 or AIF2. When AIF1CLK is selected as the SYSCLK source (SYSCLK\_SRC = 0), then the ST\_HPF cut-off frequency is scaled according to the AIF1\_SR register. When AIF2CLK is selected as the SYSCLK source (SYSCLK\_SRC = 1), then the ST\_HPF cut-off frequency is scaled according to the AIF2\_SR

register. See "Clocking and Sample Rates" for further details of the system clocks and control registers.

REGISTER ADDRESS	BIT	LABEL	DEFAULT	DESCRIPTION
R1536 (0600h) DAC1 Mixer Volumes	8:5	ADCR_DAC1_V OL [3:0]	0000	Sidetone STR to DAC1L and DAC1R Volume 0000 = -36dB 0001 = -33dB .... (3dB steps) 1011 = -3dB 1100 = 0dB (see Table 18 for gain range)
	3:0	ADCL_DAC1_V OL [3:0]	0000	Sidetone STL to DAC1L and DAC1R Volume 0000 = -36dB 0001 = -33dB .... (3dB steps) 1011 = -3dB 1100 = 0dB (see Table 18 for gain range)
R1539 (0603h) AIF2ADC Mixer Volumes	8:5	ADCR_AIF2ADC _VOL [3:0]	0000	Sidetone STR to AIF2 Tx Volume 0000 = -36dB 0001 = -33dB .... (3dB steps) 1011 = -3dB 1100 = 0dB (see Table 18 for gain range)
	3:0	ADCL_AIF2ADC _VOL [3:0]	0000	Sidetone STL to AIF2 Tx Volume 0000 = -36dB 0001 = -33dB .... (3dB steps) 1011 = -3dB 1100 = 0dB (see Table 18 for gain range)
R1569 (0621h) Sidetone	9:7	ST_HPF_CUT [2:0]	000	Sidetone HPF cut-off frequency (relative to 44.1kHz sample rate) 000 = 2.7kHz 001 = 1.35kHz 010 = 675Hz 011 = 370Hz 100 = 180Hz 101 = 90Hz 110 = 45Hz 111 = Reserved Note - the cut-off frequencies scale with the Digital Mixing (SYSCLK) clocking rate. The quoted figures apply to 44.1kHz sample rate.
	6	ST_HPF	0	Digital Sidetone HPF Select 0 = Disabled 1 = Enabled

Table 17 Digital Sidetone Volume Control

ADCR_DAC1_VOL, ADCL_AIF2ADC_VOL, ADCR_DAC1_VOL or ADCL_AIF2ADC_VOL	SIDETONE GAIN (dB)
0000	-36
0001	-33
0010	-30
0011	-27
0100	-24
0101	-21
0110	-18
0111	-15
1000	-12
1001	-9
1010	-6
1011	-3
1100	0
1101	0
1110	0
1111	0

Table 18 Digital Sidetone Volume Range

### DAC OUTPUT DIGITAL MIXING

There are two DAC digital mixers, one for each DAC. The inputs to each DAC mixer comprise signals from AIF1, AIF2 and the digital sidetone signals.

Note that the Left/Right channels of the AIF1 and AIF2 inputs can be inverted or interchanged if required; see "Digital Audio Interface Control".

The DAC output mixer controls are defined in Table 19.

REGISTER ADDRESS	BIT	LABEL	DEFAULT	DESCRIPTION
R1537 (0601h) DAC1 Left Mixer Routing	5	ADCR_TO_DAC 1L	0	Enable Sidetone STR to DAC1L 0 = Disabled 1 = Enabled
	4	ADCL_TO_DAC 1L	0	Enable Sidetone STL to DAC1L 0 = Disabled 1 = Enabled
	2	AIF2DACL_TO_ DAC1L	0	Enable AIF2 (Left) to DAC1L 0 = Disabled 1 = Enabled
	0	AIF1DAC1L_TO_ DAC1L	0	Enable AIF1 (Left) to DAC1L 0 = Disabled 1 = Enabled
R1538 (0602h) DAC1 Right Mixer Routing	5	ADCR_TO_DAC 1R	0	Enable Sidetone STR to DAC1R 0 = Disabled 1 = Enabled
	4	ADCL_TO_DAC 1R	0	Enable Sidetone STL to DAC1R 0 = Disabled 1 = Enabled
	2	AIF2DACR_TO_ DAC1R	0	Enable AIF2 (Right) to DAC1R 0 = Disabled

REGISTER ADDRESS	BIT	LABEL	DEFAULT	DESCRIPTION
				1 = Enabled
	0	AIF1DAC1R_TO_DAC1R	0	Enable AIF1 (Right) to DAC1R 0 = Disabled 1 = Enabled

Table 19 DAC Output Digital Mixing

**AUDIO INTERFACE 2 (AIF2) OUTPUT DIGITAL MIXING**

There are two digital mixers associated with the AIF2 output channels. The inputs to each AIF2 mixer comprise signals from AIF1, AIF2 and the digital sidetone signals.

Note that the Left/Right channels of the AIF1 and AIF2 inputs can be inverted or interchanged if required; see "Digital Audio Interface Control".

The AIF2 output mixer controls are defined in Table 20.

REGISTER ADDRESS	BIT	LABEL	DEFAULT	DESCRIPTION
R1540 (0604h) AIF2ADC Left Mixer Routing	5	ADCR_TO_AIF2 ADCL	0	Enable Sidetone STR to AIF2 Tx (Left) 0 = Disabled 1 = Enabled
	4	ADCL_TO_AIF2 ADCL	0	Enable Sidetone STL to AIF2 Tx (Left) 0 = Disabled 1 = Enabled
	2	AIF2ADCL_TO_AIF2ADCL	0	Enable AIF2 (Left) to AIF2 Tx (Left) 0 = Disabled 1 = Enabled
	0	AIF1DAC1L_TO_AIF2ADCL	0	Enable AIF1 (Left) to AIF2 Tx (Left) 0 = Disabled 1 = Enabled
R1541 (0605h) AIF2ADC Right Mixer Routing	5	ADCR_TO_AIF2 ADCR	0	Enable Sidetone STR to AIF2 Tx (Right) 0 = Disabled 1 = Enabled
	4	ADCL_TO_AIF2 ADCR	0	Enable Sidetone STL to AIF2 Tx (Right) 0 = Disabled 1 = Enabled
	2	AIF2ADCR_TO_AIF2ADCR	0	Enable AIF2 (Right) to AIF2 Tx (Right) 0 = Disabled 1 = Enabled
	0	AIF1DAC1R_TO_AIF2ADCR	0	Enable AIF1 (Right) to AIF2 Tx (Right) 0 = Disabled 1 = Enabled

Table 20 AIF2 Output Mixing



**DIGITAL VOLUME (DAC AND AIF2 OUTPUT PATHS)**

The volume level of each DAC output mixer path and each AIF2 output mixer path can be controlled digitally over a range from -71.625dB to +12dB in 0.375dB steps. The level of attenuation for an eight-bit code X is given by:

$$0.375 \times (X-192) \text{ dB for } 1 \leq X \leq 224; \quad \text{MUTE for } X = 0; \quad 12\text{dB to } 224 \leq X \leq 255$$

Each of the digital output mixer paths can be muted using the soft mute control bits described in Table 21. The WM1811A always applies a soft mute, where the volume is decreased gradually. The un-mute behaviour is configurable, as described in the "Digital Volume Soft Mute and Soft Un-Mute" section.

The DAC1\_VU and AIF2TX\_VU bits control the loading of digital volume control data. When DAC1\_VU is set to 0, the DAC1L\_VOL or DAC1R\_VOL control data will be loaded into the respective control register, but will not actually change the digital gain setting. Both left and right gain settings are updated when a 1 is written to DAC1\_VU. This makes it possible to update the gain of both channels simultaneously. A similar function for AIF2TXL and AIF2TXR is controlled by the AIF2TX\_VU register bit.

REGISTER ADDRESS	BIT	LABEL	DEFAULT	DESCRIPTION
R1552 (0610h) DAC1 Left Volume	9	DAC1L_MUTE	1	DAC1L Soft Mute Control 0 = DAC Un-mute 1 = DAC Mute
	8	DAC1_VU	N/A	DAC1L and DAC1R Volume Update Writing a 1 to this bit will cause the DAC1L and DAC1R volume to be updated simultaneously
	7:0	DAC1L_VOL [7:0]	C0h (0dB)	DAC1L Digital Volume 00h = MUTE 01h = -71.625dB ... (0.375dB steps) C0h = 0dB ... (0.375dB steps) E0h = 12dB FFh = 12dB (See Table 22 for volume range)
R1553 (0611h) DAC1 Right Volume	9	DAC1R_MUTE	1	DAC1R Soft Mute Control 0 = DAC Un-mute 1 = DAC Mute
	8	DAC1_VU	N/A	DAC1L and DAC1R Volume Update Writing a 1 to this bit will cause the DAC1L and DAC1R volume to be updated simultaneously
	7:0	DAC1R_VOL [7:0]	C0h (0dB)	DAC1R Digital Volume 00h = MUTE 01h = -71.625dB ... (0.375dB steps) C0h = 0dB ... (0.375dB steps) E0h = 12dB FFh = 12dB (See Table 22 for volume range)
R1554 (0612h) AIF2TX Left Volume	9	AIF2TXL_MUTE	1	AIF2 Tx (Left) Soft Mute Control 0 = Un-mute 1 = Mute

REGISTER ADDRESS	BIT	LABEL	DEFAULT	DESCRIPTION
	8	AIF2TX_VU	N/A	AIF2 Tx (Left) and AIF2 Tx (Right) Volume Update Writing a 1 to this bit will cause the AIF2TXL and AIF2TXR volume to be updated simultaneously
	7:0	AIF2TXL_V OL [7:0]	C0h (0dB)	AIF2 Tx (Left) Volume Digital Volume 00h = MUTE 01h = -71.625dB ... (0.375dB steps) C0h = 0dB ... (0.375dB steps) E0h = 12dB FFh = 12dB (See Table 22for volume range)
R1555 (0613h) AIF2TX Right Volume	9	AIF2TXR_MUTE	1	AIF2 Tx (Right) Soft Mute Control 0 = DAC Un-mute 1 = DAC Mute
	8	AIF2TX_VU	N/A	AIF2 Tx (Left) and AIF2 Tx (Right) Volume Update Writing a 1 to this bit will cause the AIF2TXL and AIF2TXR volume to be updated simultaneously
	7:0	AIF2TXR_V OL [7:0]	C0h (0dB)	AIF2 Tx (Right) Digital Volume 00h = MUTE 01h = -71.625dB ... (0.375dB steps) C0h = 0dB ... (0.375dB steps) E0h = 12dB FFh = 12dB (See Table 22for volume range)

Table 21 DAC and AIF2 Output Digital Volume Control

DAC / AIF2 Tx Volume	Volume (dB)	DAC / AIF2 Tx Volume	Volume (dB)	DAC / AIF2 Tx Volume	Volume (dB)	DAC / AIF2 Tx Volume	Volume (dB)
0h	MUTE	40h	-48.000	80h	-24.000	C0h	0.000
1h	-71.625	41h	-47.625	81h	-23.625	C1h	0.375
2h	-71.250	42h	-47.250	82h	-23.250	C2h	0.750
3h	-70.875	43h	-46.875	83h	-22.875	C3h	1.125
4h	-70.500	44h	-46.500	84h	-22.500	C4h	1.500
5h	-70.125	45h	-46.125	85h	-22.125	C5h	1.875
6h	-69.750	46h	-45.750	86h	-21.750	C6h	2.250
7h	-69.375	47h	-45.375	87h	-21.375	C7h	2.625
8h	-69.000	48h	-45.000	88h	-21.000	C8h	3.000
9h	-68.625	49h	-44.625	89h	-20.625	C9h	3.375
Ah	-68.250	4Ah	-44.250	8Ah	-20.250	CAh	3.750
Bh	-67.875	4Bh	-43.875	8Bh	-19.875	CBh	4.125
Ch	-67.500	4Ch	-43.500	8Ch	-19.500	CCh	4.500
Dh	-67.125	4Dh	-43.125	8Dh	-19.125	CDh	4.875
Eh	-66.750	4Eh	-42.750	8Eh	-18.750	CEh	5.250
Fh	-66.375	4Fh	-42.375	8Fh	-18.375	CFh	5.625
10h	-66.000	50h	-42.000	90h	-18.000	D0h	6.000
11h	-65.625	51h	-41.625	91h	-17.625	D1h	6.375
12h	-65.250	52h	-41.250	92h	-17.250	D2h	6.750
13h	-64.875	53h	-40.875	93h	-16.875	D3h	7.125
14h	-64.500	54h	-40.500	94h	-16.500	D4h	7.500
15h	-64.125	55h	-40.125	95h	-16.125	D5h	7.875
16h	-63.750	56h	-39.750	96h	-15.750	D6h	8.250
17h	-63.375	57h	-39.375	97h	-15.375	D7h	8.625
18h	-63.000	58h	-39.000	98h	-15.000	D8h	9.000
19h	-62.625	59h	-38.625	99h	-14.625	D9h	9.375
1Ah	-62.250	5Ah	-38.250	9Ah	-14.250	DAh	9.750
1Bh	-61.875	5Bh	-37.875	9Bh	-13.875	DBh	10.125
1Ch	-61.500	5Ch	-37.500	9Ch	-13.500	DCh	10.500
1Dh	-61.125	5Dh	-37.125	9Dh	-13.125	DDh	10.875
1Eh	-60.750	5Eh	-36.750	9Eh	-12.750	DEh	11.250
1Fh	-60.375	5Fh	-36.375	9Fh	-12.375	DFh	11.625
20h	-60.000	60h	-36.000	A0h	-12.000	E0h	12.000
21h	-59.625	61h	-35.625	A1h	-11.625	E1h	12.000
22h	-59.250	62h	-35.250	A2h	-11.250	E2h	12.000
23h	-58.875	63h	-34.875	A3h	-10.875	E3h	12.000
24h	-58.500	64h	-34.500	A4h	-10.500	E4h	12.000
25h	-58.125	65h	-34.125	A5h	-10.125	E5h	12.000
26h	-57.750	66h	-33.750	A6h	-9.750	E6h	12.000
27h	-57.375	67h	-33.375	A7h	-9.375	E7h	12.000
28h	-57.000	68h	-33.000	A8h	-9.000	E8h	12.000
29h	-56.625	69h	-32.625	A9h	-8.625	E9h	12.000
2Ah	-56.250	6Ah	-32.250	AAh	-8.250	EAh	12.000
2Bh	-55.875	6Bh	-31.875	ABh	-7.875	EBh	12.000
2Ch	-55.500	6Ch	-31.500	ACh	-7.500	ECh	12.000
2Dh	-55.125	6Dh	-31.125	ADh	-7.125	EDh	12.000
2Eh	-54.750	6Eh	-30.750	AEh	-6.750	EEh	12.000
2Fh	-54.375	6Fh	-30.375	AFh	-6.375	EFh	12.000
30h	-54.000	70h	-30.000	B0h	-6.000	F0h	12.000
31h	-53.625	71h	-29.625	B1h	-5.625	F1h	12.000
32h	-53.250	72h	-29.250	B2h	-5.250	F2h	12.000
33h	-52.875	73h	-28.875	B3h	-4.875	F3h	12.000
34h	-52.500	74h	-28.500	B4h	-4.500	F4h	12.000
35h	-52.125	75h	-28.125	B5h	-4.125	F5h	12.000
36h	-51.750	76h	-27.750	B6h	-3.750	F6h	12.000
37h	-51.375	77h	-27.375	B7h	-3.375	F7h	12.000
38h	-51.000	78h	-27.000	B8h	-3.000	F8h	12.000
39h	-50.625	79h	-26.625	B9h	-2.625	F9h	12.000
3Ah	-50.250	7Ah	-26.250	BAh	-2.250	FAh	12.000
3Bh	-49.875	7Bh	-25.875	BBh	-1.875	FBh	12.000
3Ch	-49.500	7Ch	-25.500	BCh	-1.500	FCh	12.000
3Dh	-49.125	7Dh	-25.125	BDh	-1.125	FDh	12.000
3Eh	-48.750	7Eh	-24.750	BEh	-0.750	FEh	12.000
3Fh	-48.375	7Fh	-24.375	BFh	-0.375	FFh	12.000

Table 22 DAC and AIF2 Output Digital Volume Range

**DIGITAL VOLUME SOFT MUTE AND SOFT UN-MUTE**

The WM1811A has a soft mute function which ensures that a gradual attenuation is applied to the DAC output mixers or AIF2 output mixers when the associated mute is asserted. The soft mute rate can be selected using the DAC\_MUTERATE bit.

When a mute bit is disabled, the gain will either gradually ramp back up to the digital gain setting, or return instantly to the digital gain setting, depending on the DAC\_SOFTMUTEMODE register bit. If the gradual un-mute ramp is selected (DAC\_SOFTMUTEMODE = 1), then the un-mute rate is determined by the DAC\_MUTERATE bit.

Note that each DAC (or AIF2 output mixer) is soft-muted by default. To play back an audio signal, the mute must first be disabled by setting the applicable mute control to 0 (see Table 21).

Soft Mute Mode would typically be enabled (DAC\_SOFTMUTEMODE = 1) when using mute during playback of audio data so that when the mute is subsequently disabled, the volume increase will not create pop noise by jumping immediately to the previous volume level (e.g. resuming playback after pausing during a track).

Soft Mute Mode would typically be disabled (DAC\_SOFTMUTEMODE = 0) when un-muting at the start of a music file, in order that the first part of the track is not attenuated (e.g. when starting playback of a new track, or resuming playback after pausing between tracks).

The DAC soft-mute function is illustrated in Figure 19 for DAC1L and DAC1R. The same function is applicable to AIF2TXL and AIF2TXR also.

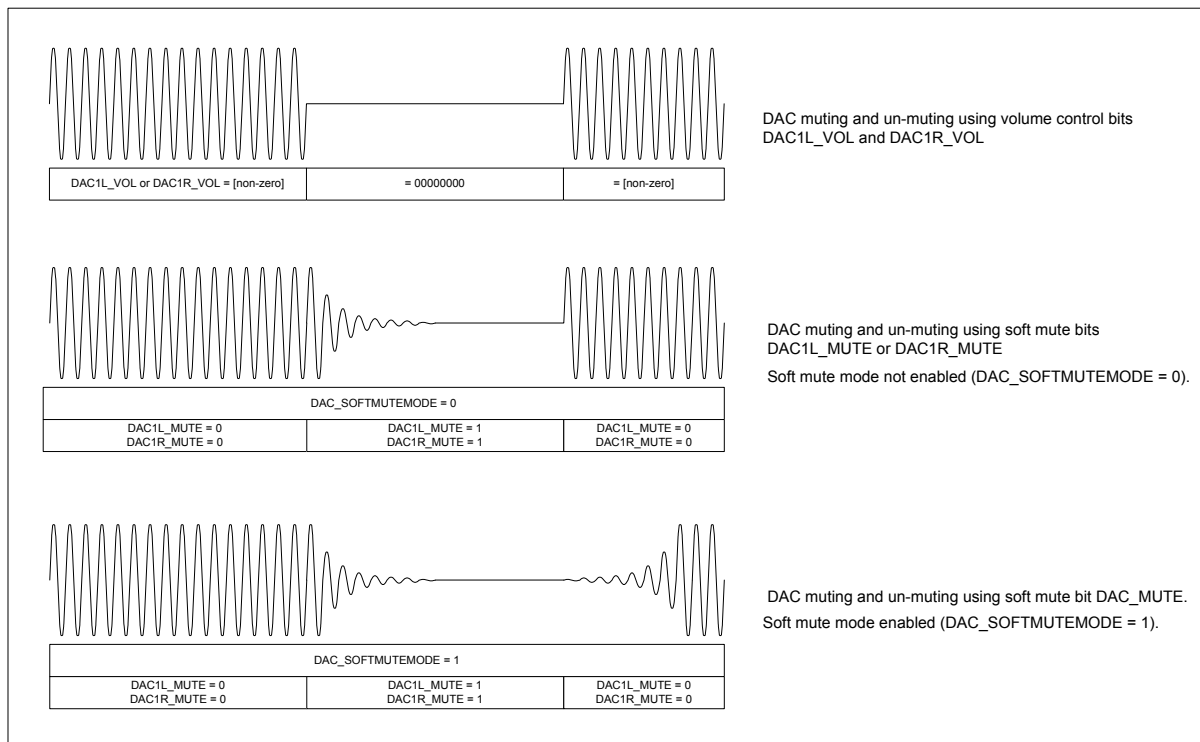

**Figure 19 Digital Volume Soft Mute Control**

The DAC Soft Mute register controls are defined in Table 23.

The volume ramp rate during soft mute and un-mute is controlled by the DAC\_MUTERATE bit. Ramp rates of  $fs/32$  and  $fs/2$  are selectable. The ramp rate determines the rate at which the volume will be increased or decreased. Note that the actual ramp time depends on the extent of the difference between the muted and un-muted volume settings.

REGISTER ADDRESS	BIT	LABEL	DEFAULT	DESCRIPTION
R1556 (0614h) DAC Softmute	1	DAC_SOFT MUTEMODE	0	DAC/AIF2 Digital Output Mixer Unmute Ramp select 0 = Unmuting the DAC / AIF2 volume will immediately apply the DAC1[L/R]_VOL or AIF2TX[L/R]_VOL settings. 1 = Unmuting the DAC / AIF2 volume will cause a gradual ramp up to the DAC1[L/R]_VOL or AIF2TX[L/R]_VOL settings.
	0	DAC_MUTE RATE	0	DAC/AIF2 Digital Output Mixer Soft Mute Ramp Rate 0 = Fast ramp (fs/2, maximum ramp time is 10.7ms at fs=48k) 1 = Slow ramp (fs/32, maximum ramp time is 171ms at fs=48k) (Note: ramp rate scales with sample rate.)

Table 23 Digital Volume Soft-Mute Control

**ULTRASONIC (4FS) AIF OUTPUT MODE**

The WM1811A provides an ultrasonic mode on the output paths of the AIF1 audio interface. The ultrasonic mode enables high frequency signals (such as ultrasonic microphone signals) to be output.

Ultrasonic mode is enabled on AIF1 using the AIF1ADC\_4FS register bit. When the ultrasonic mode is selected, the AIF1 output sample rate is increased by a factor of 4. For example, a 48kHz sample rate will be output at 192kHz in ultrasonic mode.

Ultrasonic mode is only supported in AIF Master mode and uses the ADCLRCLK output (not the LRCLK). When ultrasonic mode is enabled, the AIF1 must be configured in Master mode, as described in "Digital Audio Interface Control". See "General Purpose Input/Output" to configure the GPIO1 pin as ADCLRCLK1. The ADCLRCLK1 rate is controlled as described in "Digital Audio Interface Control".

When ultrasonic mode is enabled, the audio band filtering and digital volume controls (see "Digital Volume and Filter Control") are bypassed on the affected output paths.

The Dynamic Range Control (DRC) function is not available on the AIF1 output signal paths in ultrasonic mode. Note, however, that the DRC is still available on the AIF input paths in this case.

The ultrasonic (4FS) signal paths are illustrated in Figure 20. The AIF1ADC\_4FS register bit is defined in Table 24.

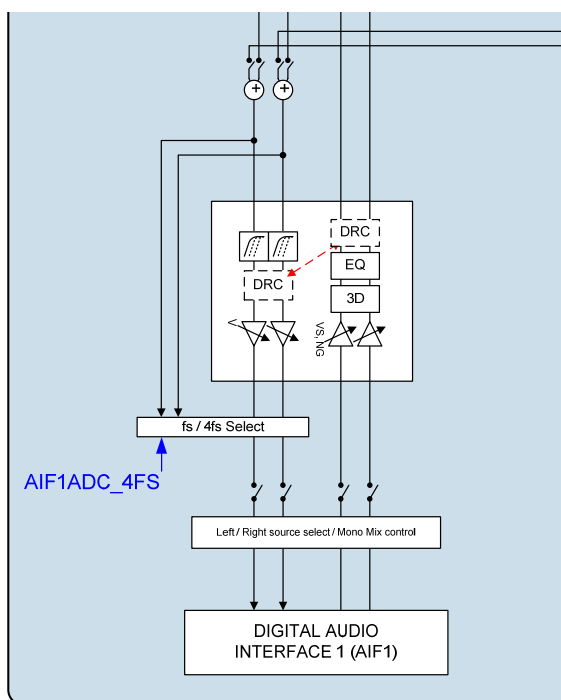

**Figure 20 Ultrasonic (4FS) Signal Paths**

REGISTER ADDRESS	BIT	LABEL	DEFAULT	DESCRIPTION
R1040 (0410h) AIF1 ADC1 Filters	15	AIF1ADC_4FS	0	Enable AIF1ADC ultrasonic mode (4FS) output, bypassing all AIF1 baseband output filtering 0 = Disabled 1 = Enabled

**Table 24 Ultrasonic (4FS) Mode Control**

## DYNAMIC RANGE CONTROL (DRC)

The Dynamic Range Control (DRC) is a circuit which can be enabled in the digital playback or digital record paths of the WM1811A audio interfaces. The function of the DRC is to adjust the signal gain in conditions where the input amplitude is unknown or varies over a wide range, e.g. when recording from microphones built into a handheld system.

The DRC can apply Compression and Automatic Level Control to the signal path. It incorporates 'anti-clip' and 'quick release' features for handling transients in order to improve intelligibility in the presence of loud impulsive noises.

The DRC also incorporates a Noise Gate function, which provides additional attenuation of very low-level input signals. This means that the signal path is quiet when no signal is present, giving an improvement in background noise level under these conditions.

The WM1811A provides two stereo Dynamic Range Controllers (DRCs); these are associated with AIF1 and AIF2 respectively. Each DRC can be enabled either in the DAC playback (AIF input) path or in the ADC record (AIF output) path, as described in the "Digital Core Architecture" section.

The DRCs are enabled in the DAC or ADCs audio signal paths using the register bits described in Table 25. Note that enabling any DRC in the DAC and ADC paths simultaneously is an invalid selection.

When the DRC is enabled in any of the ADC (digital record) paths, the associated High Pass Filter (HPF) must be enabled also; this ensures that DC offsets are removed prior to the DRC processing. The output path HPF control registers are described in Table 37 (for AIF1 output paths) and Table 45 (for AIF2 output paths). These are described in the "Digital Volume and Filter Control" section.

Note that, when ultrasonic (4FS) mode is selected on AIF1, then the DRC function is bypassed on the respective ADC (output) signal paths. The DRC may still be selected on the AIF1DAC (input) signal paths.

REGISTER ADDRESS	BIT	LABEL	DEFAULT	DESCRIPTION
R1088 (0440h) AIF1DRC1 (1)	2	AIF1DAC1_DRC_ENA	0	Enable DRC in AIF1DAC playback path 0 = Disabled 1 = Enabled
	1	AIF1ADC1L_DR C_ENA	0	Enable DRC in AIF1ADC (Left) record path 0 = Disabled 1 = Enabled
	0	AIF1ADC1R_DR C_ENA	0	Enable DRC in AIF1ADC (Right) record path 0 = Disabled 1 = Enabled
R1344 (0540h) AIF2DRC (1)	2	AIF2DAC_DRC_ENA	0	Enable DRC in AIF2DAC playback path 0 = Disabled 1 = Enabled
	1	AIF2ADCL_DRC_ENA	0	Enable DRC in AIF2ADC (Left) record path 0 = Disabled 1 = Enabled
	0	AIF2ADCR_DRC_ENA	0	Enable DRC in AIF2ADC (Right) record path 0 = Disabled 1 = Enabled

Table 25 DRC Enable

The following description of the DRC is applicable to both DRCs. The associated register control fields are described in Table 27 and Table 28 for the respective DRCs.

Note that, where the following description refers to register names, the generic prefix *[DRC]* is quoted:

- For the DRC associated with AIF1, *[DRC]* = AIF1DRC1.
- For the DRC associated with AIF2, *[DRC]* = AIF2DRC.

### DRC COMPRESSION / EXPANSION /LIMITING

The DRC supports two different compression regions, separated by a “Knee” at a specific input amplitude. In the region above the knee, the compression slope *[DRC]\_HI\_COMP* applies; in the region below the knee, the compression slope *[DRC]\_LO\_COMP* applies.

The DRC also supports a noise gate region, where low-level input signals are heavily attenuated. This function can be enabled or disabled according to the application requirements. The DRC response in this region is defined by the expansion slope *[DRC]\_NG\_EXP*.

For additional attenuation of signals in the noise gate region, an additional “knee” can be defined (shown as “Knee2” in Figure 21). When this knee is enabled, this introduces an infinitely steep drop-off in the DRC response pattern between the *[DRC]\_LO\_COMP* and *[DRC]\_NG\_EXP* regions.

The overall DRC compression characteristic in “steady state” (i.e. where the input amplitude is near-constant) is illustrated in Figure 21.

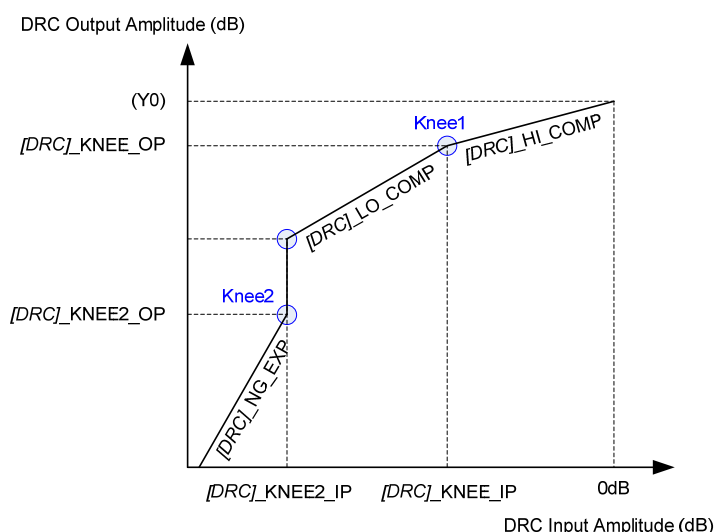

**Figure 21 DRC Response Characteristic**

The slope of the DRC response is determined by register fields *[DRC]\_HI\_COMP* and *[DRC]\_LO\_COMP*. A slope of 1 indicates constant gain in this region. A slope less than 1 represents compression (i.e. a change in input amplitude produces only a smaller change in output amplitude). A slope of 0 indicates that the target output amplitude is the same across a range of input amplitudes; this is infinite compression.

When the noise gate is enabled, the DRC response in this region is determined by the *[DRC]\_NG\_EXP* register. A slope of 1 indicates constant gain in this region. A slope greater than 1 represents expansion (i.e. a change in input amplitude produces a larger change in output amplitude).

When the *DRC\_KNEE2\_OP* knee is enabled (“Knee2” in Figure 21), this introduces the vertical line in the response pattern illustrated, resulting in infinitely steep attenuation at this point in the response.



The DRC parameters are listed in Table 26.

REF	PARAMETER	DESCRIPTION
1	[DRC]_KNEE_IP	Input level at Knee1 (dB)
2	[DRC]_KNEE_OP	Output level at Knee2 (dB)
3	[DRC]_HI_COMP	Compression ratio above Knee1
4	[DRC]_LO_COMP	Compression ratio below Knee1
5	[DRC]_KNEE2_IP	Input level at Knee2 (dB)
6	[DRC]_NG_EXP	Expansion ratio below Knee2
7	[DRC]_KNEE2_OP	Output level at Knee2 (dB)

**Table 26 DRC Response Parameters**

The noise gate is enabled when the [DRC]\_NG\_ENA register is set. When the noise gate is not enabled, parameters 5, 6, 7 above are ignored, and the [DRC]\_LO\_COMP slope applies to all input signal levels below Knee1.

The DRC\_KNEE2\_OP knee is enabled when the [DRC]\_KNEE2\_OP\_ENA register is set. When this bit is not set, then parameter 7 above is ignored, and the Knee2 position always coincides with the low end of the [DRC]\_LO\_COMP region.

The “Knee1” point in Figure 21 is determined by register fields [DRC]\_KNEE\_IP and [DRC]\_KNEE\_OP.

Parameter Y0, the output level for a 0dB input, is not specified directly, but can be calculated from the other parameters, using the equation:

$$Y0 = [DRC]_KNEE\_OP - ([DRC]_KNEE\_IP * [DRC]_HI\_COMP)$$

### GAIN LIMITS

The minimum and maximum gain applied by the DRC is set by register fields [DRC]\_MINGAIN, [DRC]\_MAXGAIN and [DRC]\_NG\_MINGAIN. These limits can be used to alter the DRC response from that illustrated in Figure 21. If the range between maximum and minimum gain is reduced, then the extent of the dynamic range control is reduced.

The minimum gain in the Compression regions of the DRC response is set by [DRC]\_MINGAIN. The minimum gain in the Noise Gate region is set by [DRC]\_NG\_MINGAIN. The minimum gain limit prevents excessive attenuation of the signal path.

The maximum gain limit set by [DRC]\_MAXGAIN prevents quiet signals (or silence) from being excessively amplified.

## DYNAMIC CHARACTERISTICS

The dynamic behaviour determines how quickly the DRC responds to changing signal levels. Note that the DRC responds to the average (RMS) signal amplitude over a period of time.

The *[DRC]\_ATK* determines how quickly the DRC gain decreases when the signal amplitude is high. The *[DRC]\_DCY* determines how quickly the DRC gain increases when the signal amplitude is low.

These register fields are described in Table 27 and Table 28. Note that the register defaults are suitable for general purpose microphone use.

## ANTI-CLIP CONTROL

The DRC includes an Anti-Clip feature to avoid signal clipping when the input amplitude rises very quickly. This feature uses a feed-forward technique for early detection of a rising signal level. Signal clipping is avoided by dynamically increasing the gain attack rate when required. The Anti-Clip feature is enabled using the *[DRC]\_ANTICLIP* bit.

Note that the feed-forward processing increases the latency in the input signal path.

Note that the Anti-Clip feature operates entirely in the digital domain. It cannot be used to prevent signal clipping in the analogue domain nor in the source signal. Analogue clipping can only be prevented by reducing the analogue signal gain or by adjusting the source signal.

Note that the Anti-Clip feature should not be enabled at the same time as the Quick Release feature (described below) on the same DRC.

## QUICK RELEASE CONTROL

The DRC includes a Quick-Release feature to handle short transient peaks that are not related to the intended source signal. For example, in handheld microphone recording, transient signal peaks sometimes occur due to user handling, key presses or accidental tapping against the microphone. The Quick Release feature ensures that these transients do not cause the intended signal to be masked by the longer time constants of *[DRC]\_DCY*.

The Quick-Release feature is enabled by setting the *[DRC]\_QR* bit. When this bit is enabled, the DRC measures the crest factor (peak to RMS ratio) of the input signal. A high crest factor is indicative of a transient peak that may not be related to the intended source signal. If the crest factor exceeds the level set by *[DRC]\_QR\_THR*, then the normal decay rate (*[DRC]\_DCY*) is ignored and a faster decay rate (*[DRC]\_QR\_DCY*) is used instead.

Note that the Quick Release feature should not be enabled at the same time as the Anti-Clip feature (described above) on the same DRC.

## SIGNAL ACTIVITY DETECT

The DRC incorporates a configurable signal detect function, allowing the signal level at the DRC input to be monitored and to be used to trigger other events. This can be used to detect the presence of a microphone signal on an ADC or digital mic channel, or can be used to detect an audio signal received over the digital audio interface.

The Peak signal level or the RMS signal level of the DRC input can be selected as the detection threshold. When the threshold condition is exceeded, an interrupt or GPIO output can be generated. See "General Purpose Input/Output" for a full description of the applicable control fields.

**DRC REGISTER CONTROLS**

The AIF1DRC control registers are described in Table 27.

The AIF2DRC control registers are described in Table 28.

REGISTER ADDRESS	BIT	LABEL	DEFAULT	DESCRIPTION
R1088(0440h) AIF1 DRC1 (1)	8	AIF1DRC1_NG_ENA	0	AIF1 DRC Noise Gate Enable 0 = Disabled 1 = Enabled
	5	AIF1DRC1_KNEE2_OP_ENA	0	AIF1 DRCKNEE2_OP Enable 0 = Disabled 1 = Enabled
	4	AIF1DRC1_QR	1	AIF1 DRC Quick-release Enable 0 = Disabled 1 = Enabled
	3	AIF1DRC1_ANTI_CLIP	1	AIF1 DRC Anti-clip Enable 0 = Disabled 1 = Enabled
R1089(0441h) AIF1 DRC1 (2)	12:9	AIF1DRC1_ATK [3:0]	0100	AIF1 DRC Gain attack rate (seconds/6dB) 0000 = Reserved 0001 = 181us 0010 = 363us 0011 = 726us 0100 = 1.45ms 0101 = 2.9ms 0110 = 5.8ms 0111 = 11.6ms 1000 = 23.2ms 1001 = 46.4ms 1010 = 92.8ms 1011 = 185.6ms 1100-1111 = Reserved
	8:5	AIF1DRC1_DCY [3:0]	0010	AIF1 DRC Gain decay rate (seconds/6dB) 0000 = 186ms 0001 = 372ms 0010 = 743ms 0011 = 1.49s 0100 = 2.97s 0101 = 5.94s 0110 = 11.89s 0111 = 23.78s 1000 = 47.56s 1001-1111 = Reserved
	4:2	AIF1DRC1_MIN_GAIN [2:0]	001	AIF1 DRC Minimum gain to attenuate audio signals 000 = 0dB 001 = -12dB (default) 010 = -18dB 011 = -24dB 100 = -36dB 101 = Reserved 11X = Reserved

REGISTER ADDRESS	BIT	LABEL	DEFAULT	DESCRIPTION
	1:0	AIF1DRC1_MAX GAIN [1:0]	01	AIF1 DRC Maximum gain to boost audio signals (dB) 00 = 12dB 01 = 18dB 10 = 24dB 11 = 36dB
R1090(0442h) AIF1 DRC1 (3)	15:12	AIF1DRC1_NG_MINGAIN [3:0]	0000	AIF1 DRC Minimum gain to attenuate audio signals when the noise gate is active. 0000 = -36dB 0001 = -30dB 0010 = -24dB 0011 = -18dB 0100 = -12dB 0101 = -6dB 0110 = 0dB 0111 = 6dB 1000 = 12dB 1001 = 18dB 1010 = 24dB 1011 = 30dB 1100 = 36dB 1101 to 1111 = Reserved
	11:10	AIF1DRC1_NG_EXP [1:0]	00	AIF1 DRC Noise Gate slope 00 = 1 (no expansion) 01 = 2 10 = 4 11 = 8
	9:8	AIF1DRC1_QR_THR [1:0]	00	AIF1 DRC Quick-release threshold (crest factor in dB) 00 = 12dB 01 = 18dB 10 = 24dB 11 = 30dB
	7:6	AIF1DRC1_QR_DCY [1:0]	00	AIF1 DRC Quick-release decay rate (seconds/6dB) 00 = 0.725ms 01 = 1.45ms 10 = 5.8ms 11 = Reserved
	5:3	AIF1DRC1_HI_COMP [2:0]	000	AIF1 DRC Compressor slope (upper region) 000 = 1 (no compression) 001 = 1/2 010 = 1/4 011 = 1/8 100 = 1/16 101 = 0 110 = Reserved 111 = Reserved

REGISTER ADDRESS	BIT	LABEL	DEFAULT	DESCRIPTION
	2:0	AIF1DRC1_LO_COMP [2:0]	000	AIF1 DRC Compressor slope (lower region) 000 = 1 (no compression) 001 = 1/2 010 = 1/4 011 = 1/8 100 = 0 101 = Reserved 11X = Reserved
R1091(0443h) AIF1 DRC1 (4)	10:5	AIF1DRC1_KNEE_IP [5:0]	000000	AIF1 DRC Input signal level at the Compressor 'Knee'. 000000 = 0dB 000001 = -0.75dB 000010 = -1.5dB ... (-0.75dB steps) 111100 = -45dB 111101 = Reserved 11111X = Reserved
	4:0	AIF1DRC1_KNEE_OP [4:0]	00000	AIF1 DRC Output signal at the Compressor 'Knee'. 00000 = 0dB 00001 = -0.75dB 00010 = -1.5dB ... (-0.75dB steps) 11110 = -22.5dB 11111 = Reserved
R1092(0444h) AIF1 DRC1 (5)	9:5	AIF1DRC1_KNEE2_IP [4:0]	00000	AIF1 DRC Input signal level at the Noise Gate threshold 'Knee2'. 00000 = -36dB 00001 = -37.5dB 00010 = -39dB ... (-1.5dB steps) 11110 = -81dB 11111 = -82.5dB Only applicable when AIF1DRC1_NG_ENA = 1.
	4:0	AIF1DRC1_KNEE2_OP [4:0]	00000	AIF1 DRC Output signal at the Noise Gate threshold 'Knee2'. 00000 = -30dB 00001 = -31.5dB 00010 = -33dB ... (-1.5dB steps) 11110 = -75dB 11111 = -76.5dB Only applicable when AIF1DRC1_KNEE2_OP_ENA = 1.

Table 27 AIF1 DRC Controls

REGISTER ADDRESS	BIT	LABEL	DEFAULT	DESCRIPTION
R1344 (0540h) AIF2DRC (1)	8	AIF2DRC_NG_ENA	0	AIF2 DRC Noise Gate Enable 0 = Disabled 1 = Enabled
	5	AIF2DRC_KNEE2_OP_ENA	0	AIF2 DRCKNEE2_OP Enable 0 = Disabled 1 = Enabled
	4	AIF2DRC_QR	1	AIF2 DRC Quick-release Enable 0 = Disabled 1 = Enabled
	3	AIF2DRC_ANTI_CLIP	1	AIF2 DRC Anti-clip Enable 0 = Disabled 1 = Enabled
R1345 (0541h) AIF2DRC (2)	12:9	AIF2DRC_ATK [3:0]	0100	AIF2 DRC Gain attack rate (seconds/6dB) 0000 = Reserved 0001 = 181us 0010 = 363us 0011 = 726us 0100 = 1.45ms 0101 = 2.9ms 0110 = 5.8ms 0111 = 11.6ms 1000 = 23.2ms 1001 = 46.4ms 1010 = 92.8ms 1011 = 185.6ms 1100-1111 = Reserved
	8:5	AIF2DRC_DCY [3:0]	0010	AIF2 DRC Gain decay rate (seconds/6dB) 0000 = 186ms 0001 = 372ms 0010 = 743ms 0011 = 1.49s 0100 = 2.97s 0101 = 5.94s 0110 = 11.89s 0111 = 23.78s 1000 = 47.56s 1001-1111 = Reserved
	4:2	AIF2DRC_MINGAIN [2:0]	001	AIF2 DRC Minimum gain to attenuate audio signals 000 = 0dB 001 = -12dB (default) 010 = -18dB 011 = -24dB 100 = -36dB 101 = Reserved 11X = Reserved

REGISTER ADDRESS	BIT	LABEL	DEFAULT	DESCRIPTION
	1:0	AIF2DRC_MAX GAIN [1:0]	01	AIF2 DRC Maximum gain to boost audio signals (dB) 00 = 12dB 01 = 18dB 10 = 24dB 11 = 36dB
R1346 (0542h) AIF2DRC (3)	15:12	AIF2DRC_NG_MINGAIN [3:0]	0000	AIF2 DRC Minimum gain to attenuate audio signals when the noise gate is active. 0000 = -36dB 0001 = -30dB 0010 = -24dB 0011 = -18dB 0100 = -12dB 0101 = -6dB 0110 = 0dB 0111 = 6dB 1000 = 12dB 1001 = 18dB 1010 = 24dB 1011 = 30dB 1100 = 36dB 1101 to 1111 = Reserved
	11:10	AIF2DRC_NG_EXP [1:0]	00	AIF2 DRC Noise Gate slope 00 = 1 (no expansion) 01 = 2 10 = 4 11 = 8
	9:8	AIF2DRC_QR_THR [1:0]	00	AIF2 DRC Quick-release threshold (crest factor in dB) 00 = 12dB 01 = 18dB 10 = 24dB 11 = 30dB
	7:6	AIF2DRC_QR_DECY [1:0]	00	AIF2 DRC Quick-release decay rate (seconds/6dB) 00 = 0.725ms 01 = 1.45ms 10 = 5.8ms 11 = Reserved
	5:3	AIF2DRC_HI_COMP [2:0]	000	AIF2 DRC Compressor slope (upper region) 000 = 1 (no compression) 001 = 1/2 010 = 1/4 011 = 1/8 100 = 1/16 101 = 0 110 = Reserved 111 = Reserved

REGISTER ADDRESS	BIT	LABEL	DEFAULT	DESCRIPTION
	2:0	AIF2DRC_LO_C OMP [2:0]	000	AIF2 DRC Compressor slope (lower region) 000 = 1 (no compression) 001 = 1/2 010 = 1/4 011 = 1/8 100 = 0 101 = Reserved 11X = Reserved
R1347 (0543h) AIF2DRC (4)	10:5	AIF2DRC_KNEE _IP [5:0]	000000	AIF2 DRC Input signal level at the Compressor 'Knee'. 000000 = 0dB 000001 = -0.75dB 000010 = -1.5dB ... (-0.75dB steps) 111100 = -45dB 111101 = Reserved 11111X = Reserved
	4:0	AIF2DRC_KNEE _OP [4:0]	00000	AIF2 DRC Output signal at the Compressor 'Knee'. 00000 = 0dB 00001 = -0.75dB 00010 = -1.5dB ... (-0.75dB steps) 11110 = -22.5dB 11111 = Reserved
R1348 (0544h) AIF2DRC (5)	9:5	AIF2DRC_KNEE 2_IP [4:0]	00000	AIF2 DRC Input signal level at the Noise Gate threshold 'Knee2'. 00000 = -36dB 00001 = -37.5dB 00010 = -39dB ... (-1.5dB steps) 11110 = -81dB 11111 = -82.5dB Only applicable when AIF2DRC_NG_ENA = 1.
	4:0	AIF2DRC_KNEE 2_OP [4:0]	00000	AIF2 DRC Output signal at the Noise Gate threshold 'Knee2'. 00000 = -30dB 00001 = -31.5dB 00010 = -33dB ... (-1.5dB steps) 11110 = -75dB 11111 = -76.5dB Only applicable when AIF2DRC_KNEE2_OP_ENA = 1.

Table 28 AIF2 DRC Controls



## RETUNE™ MOBILE PARAMETRIC EQUALIZER (EQ)

The ReTune™ Mobile Parametric EQ is a circuit which can be enabled in the digital playback path of the WM1811A audio interfaces. The function of the EQ is to adjust the frequency characteristic of the output in order to compensate for unwanted frequency characteristics in the loudspeaker (or other output transducer). It can also be used to tailor the response according to user preferences, for example to accentuate or attenuate specific frequency bands to emulate different sound profiles or environments e.g. concert hall, rock etc.

The WM1811A provides two stereo EQ circuits; these are associated with AIF1 and AIF2 respectively. The EQ is enabled in these signal paths using the register bits described in Table 29.

REGISTER ADDRESS	BIT	LABEL	DEFAULT	DESCRIPTION
R1152 (0480h) AIF1 DAC1 EQ Gains (1)	0	AIF1DAC1_EQ_ENA	0	Enable EQ in AIF1DAC playback path 0 = Disabled 1 = Enabled
R1408 (0580h) AIF2 EQ Gains (1)	0	AIF2DAC_EQ_ENA	0	Enable EQ in AIF2DAC playback path 0 = Disabled 1 = Enabled

**Table 29 ReTune™ Mobile Parametric EQ Enable**

The following description of the EQ is applicable to both EQ circuits. The associated register control fields are described in Table 31 and Table 32 for the respective EQs. The EQ provides selective control of 5 frequency bands as described below.

The low frequency band (Band 1) filter can be configured either as a peak filter or a shelving filter. When configured as a shelving filter, it provides adjustable gain below the Band 1 cut-off frequency. As a peak filter, it provides adjustable gain within a defined frequency band that is centred on the Band 1 frequency.

The mid frequency bands (Band 2, Band 3, Band 4) filters are peak filters, which provide adjustable gain around the respective centre frequency.

The high frequency band (Band 5) filter is a shelving filter, which provides adjustable gain above the Band 5 cut-off frequency.

The EQ can be configured to operate in two modes - "Default" mode or "ReTune™ Mobile" mode. The associated register control fields are described in Table 31 and Table 32 for the respective EQs.

### DEFAULT MODE (5-BAND PARAMETRIC EQ)

In default mode, the cut-off/centre frequencies are fixed as per Table 30. The filter bandwidths are also fixed in default mode. The gain of the individual bands (-12dB to +12dB) can be controlled as described in Table 31.

The cut-off / centre frequencies noted in Table 30 are applicable to a sample rate of 48kHz. When using other sample rates, these frequencies will be scaled in proportion to the selected sample rate for the associated Audio Interface (AIF1 or AIF2).

If AIF1 and AIF2 are operating at different sample rates, then the cut-off / centre frequencies will be different for the two interfaces. Note that the frequencies can be set to other values by using the features described in "ReTune™ Mobile Mode".

EQ BAND	CUT-OFF/CENTRE FREQUENCY
1	100 Hz
2	300 Hz
3	875 Hz
4	2400 Hz
5	6900 Hz

Table 30 EQ Band Cut-off / Centre Frequencies

REGISTER ADDRESS	BIT	LABEL	DEFAULT	DESCRIPTION
R1152 (0480h) AIF1 DAC1 EQ Gains (1)	15:11	AIF1DAC1_EQ _B1_GAIN [4:0]	01100 (0dB)	AIF1EQ Band 1 Gain -12dB to +12dB in 1dB steps (see Table 33 for gain range)
	10:6	AIF1DAC1_EQ _B2_GAIN [4:0]	01100 (0dB)	AIF1EQ Band 2 Gain -12dB to +12dB in 1dB steps (see Table 33 for gain range)
	5:1	AIF1DAC1_EQ _B3_GAIN [4:0]	01100 (0dB)	AIF1EQ Band 3 Gain -12dB to +12dB in 1dB steps (see Table 33 for gain range)
R1153 (0481h) AIF1 DAC1 EQ Gains (2)	15:11	AIF1DAC1_EQ _B4_GAIN [4:0]	01100 (0dB)	AIF1EQ Band 4 Gain -12dB to +12dB in 1dB steps (see Table 33 for gain range)
	10:6	AIF1DAC1_EQ _B5_GAIN [4:0]	01100 (0dB)	AIF1 EQ Band 5 Gain -12dB to +12dB in 1dB steps (see Table 33 for gain range)
	0	AIF1DAC1_EQ _MODE	0	AIF1 EQ Band 1 Mode 0 = Shelving filter 1 = Peak filter

Table 31 AIF1 EQ Band Gain Control

REGISTER ADDRESS	BIT	LABEL	DEFAULT	DESCRIPTION
R1408 (0580h) AIF2 EQ Gains (1)	15:11	AIF2DAC_EQ_ B1_GAIN [4:0]	01100 (0dB)	AIF2 EQ Band 1 Gain -12dB to +12dB in 1dB steps (see Table 33 for gain range)
	10:6	AIF2DAC_EQ_ B2_GAIN [4:0]	01100 (0dB)	AIF2EQ Band 2 Gain -12dB to +12dB in 1dB steps (see Table 33 for gain range)
	5:1	AIF2DAC_EQ_ B3_GAIN [4:0]	01100 (0dB)	AIF2EQ Band 3 Gain -12dB to +12dB in 1dB steps (see Table 33 for gain range)
R1409 (0581h) AIF2 EQ Gains (2)	15:11	AIF2DAC_EQ_ B4_GAIN [4:0]	01100 (0dB)	AIF2EQ Band 4 Gain -12dB to +12dB in 1dB steps (see Table 33 for gain range)
	10:6	AIF2DAC_EQ_ B5_GAIN [4:0]	01100 (0dB)	AIF2EQ Band 5 Gain -12dB to +12dB in 1dB steps (see Table 33 for gain range)
	0	AIF2DAC_EQ_ MODE	0	AIF2 EQ Band 1 Mode 0 = Shelving filter 1 = Peak filter

Table 32 AIF2 EQ Band Gain Control

EQ GAIN SETTING	GAIN (dB)
00000	-12
00001	-11
00010	-10
00011	-9
00100	-8
00101	-7
00110	-6
00111	-5
01000	-4
01001	-3
01010	-2
01011	-1
01100	0
01101	+1
01110	+2
01111	+3
10000	+4
10001	+5
10010	+6
10011	+7
10100	+8
10101	+9
10110	+10
10111	+11
11000	+12
11001 to 11111	Reserved

Table 33 EQ Gain Control Range

### RETUNE™ MOBILE MODE

ReTune™ Mobile mode provides a comprehensive facility for the user to define the cut-off/centre frequencies and filter bandwidth for each EQ band, in addition to the gain controls already described. This enables the EQ to be accurately customised for a specific transducer characteristic or desired sound profile.

The EQ enable and EQ gain controls are the same as defined for the default mode. The additional coefficients used in ReTune™ Mobile mode are held in registers R1154 to R1172 for AIF1, and registers R1410 to R1428 for AIF2. These coefficients are derived using tools provided in Wolfson's WISCE™ evaluation board control software.

Please contact your local Wolfson representative for more details.

Note that the WM1811A audio interfaces may operate at different sample rates concurrently. The EQ settings for each interface must be programmed relative to the applicable sample rate of the corresponding audio interface. If the audio interface sample rate is changed, then different EQ register settings will be required to achieve a given EQ response.

**EQ FILTER CHARACTERISTICS**

The filter characteristics for each frequency band are shown in Figure 22 to Figure 26. These figures show the frequency response for all available gain settings, using default cut-off/centre frequencies and bandwidth. Note that EQ Band 1 can also be configured as a Peak Filter if required.

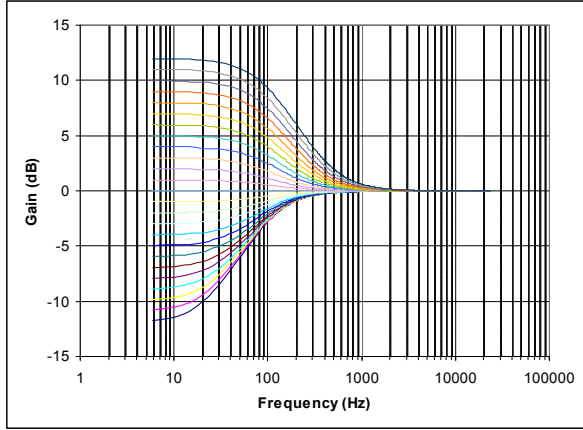

**Figure 22 EQ Band 1 – Low Freq Shelf Filter Response**

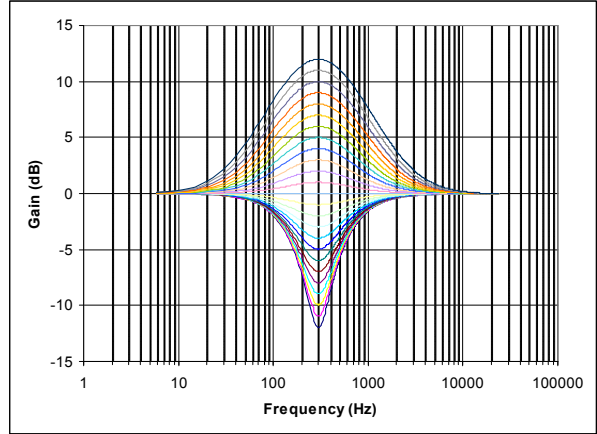

**Figure 23 EQ Band 2 – Peak Filter Response**

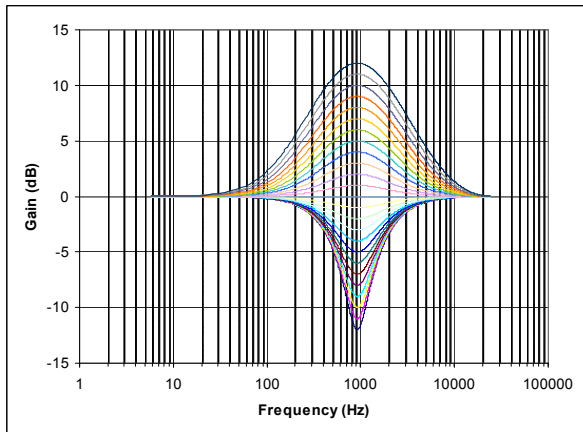

**Figure 24 EQ Band 3 – Peak Filter Response**

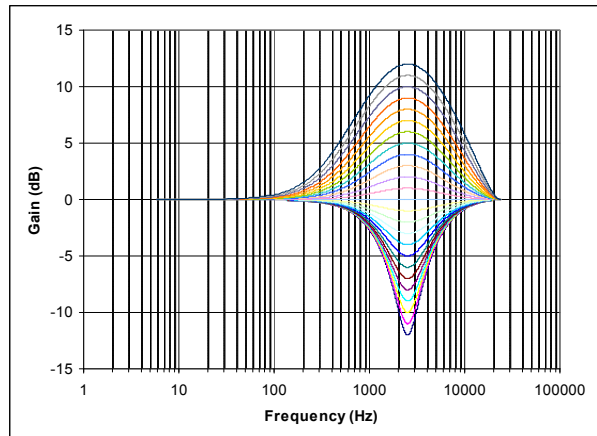

**Figure 25 EQ Band 4 – Peak Filter Response**

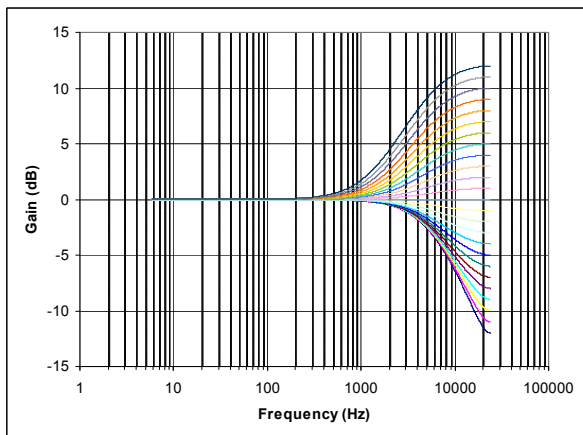

**Figure 26 EQ Band 5 – High Freq Shelf Filter Response**

### 3D STEREO EXPANSION

The 3D Stereo Expansion is an audio enhancement feature which can be enabled in the digital playback path of the WM1811A audio interfaces. This feature uses configurable cross-talk mechanisms to adjust the depth or width of the stereo audio.

The WM1811A provides two 3D Stereo Expansion circuits; these are associated with AIF1 and AIF2 respectively. The 3D Stereo Expansion is enabled and controlled in these signal paths using the register bits described in Table 34.

REGISTER ADDRESS	BIT	LABEL	DEFAULT	DESCRIPTION
R1057 (0421h) AIF1 DAC1 Filters (2)	13:9	AIF1DAC1_3D_G AIN	00000	AIF1DAC playback path 3D Stereo depth 00000 = Off 00001 = Minimum (-16dB) ...(0.915dB steps) 11111 = Maximum (+11.45dB)
	8	AIF1DAC1_3D_E NA	0	Enable 3D Stereo in AIF1DAC playback path 0 = Disabled 1 = Enabled
R1313 (0521h) AIF2 DAC Filters (2)	13:9	AIF2DAC_3D_GA IN	00000	AIF2DAC playback path 3D Stereo depth 00000 = Off 00001 = Minimum (-16dB) ...(0.915dB steps) 11111 = Maximum (+11.45dB)
	8	AIF2DAC_3D_EN A	0	Enable 3D Stereo in AIF2DAC playback path 0 = Disabled 1 = Enabled

Table 34 3D Stereo Expansion Control

## DIGITAL VOLUME AND FILTER CONTROL

This section describes the digital volume and filter controls of the WM1811A AIF paths.

Digital volume control and High Pass Filter (HPF) control is provided on the AIF1 and AIF2 output (digital record) paths.

Note that, when ultrasonic (4FS) mode is selected on AIF1, then the digital volume control and high pass filter (HPF) control are bypassed on the respective ADC (output) signal paths.

Digital volume, soft-mute and mono mix control is provided on the AIF1 and AIF2 input (digital playback) paths. A configurable noise gate function is available on each of the digital playback paths.

### AIF1 - OUTPUT PATH VOLUME CONTROL

A digital volume control is provided on the AIF1 output signal paths, allowing attenuation in the range -71.625dB to +17.625dB in 0.375dB steps. The level of attenuation for an eight-bit code X is given by:

$$0.375 \times (X-192) \text{ dB for } 1 \leq X \leq 239; \quad \text{MUTE for } X = 0 \quad +17.625\text{dB for } 239 \leq X \leq 255$$

The AIF1ADC1\_VU bits control the loading of digital volume control data. When this bit is set to 0, the AIF1ADC1L\_VOL and AIF1ADC1R\_VOL control data will be loaded into the respective control register, but will not actually change the digital gain setting.

The AIF1ADC1L\_VOL and AIF1ADC1R\_VOL gain settings are updated when a 1 is written to AIF1ADC1\_VU. This makes it possible to update the gain of left and right channels simultaneously.

REGISTER ADDRESS	BIT	LABEL	DEFAULT	DESCRIPTION
R1024(0400h) AIF1 ADC1 Left Volume	8	AIF1ADC1_VU	N/A	AIF1ADC output path Volume Update Writing a 1 to this bit will cause the AIF1ADC1L and AIF1ADC1R volume to be updated simultaneously
	7:0	AIF1ADC1L_VOL [7:0]	C0h (0dB)	AIF1ADC (Left) output path Digital Volume 00h = MUTE 01h = -71.625dB ... (0.375dB steps) EFh = +17.625dB (See Table 36 for volume range)
R1025 (0401h) AIF1 ADC1 Right Volume	8	AIF1ADC1_VU	N/A	AIF1ADC output path Volume Update Writing a 1 to this bit will cause the AIF1ADC1L and AIF1ADC1R volume to be updated simultaneously
	7:0	AIF1ADC1R_VOL [7:0]	C0h (0dB)	AIF1ADC (Right) output path Digital Volume 00h = MUTE 01h = -71.625dB ... (0.375dB steps) EFh = +17.625dB (See Table 36 for volume range)

Table 35 AIF1 Output Path Volume Control

AIF1/AIF2 Output Volume	Volume (dB)	AIF1/AIF2 Output Volume	Volume (dB)	AIF1/AIF2 Output Volume	Volume (dB)	AIF1/AIF2 Output Volume	Volume (dB)
0h	MUTE	40h	-48.000	80h	-24.000	C0h	0.000
1h	-71.625	41h	-47.625	81h	-23.625	C1h	0.375
2h	-71.250	42h	-47.250	82h	-23.250	C2h	0.750
3h	-70.875	43h	-46.875	83h	-22.875	C3h	1.125
4h	-70.500	44h	-46.500	84h	-22.500	C4h	1.500
5h	-70.125	45h	-46.125	85h	-22.125	C5h	1.875
6h	-69.750	46h	-45.750	86h	-21.750	C6h	2.250
7h	-69.375	47h	-45.375	87h	-21.375	C7h	2.625
8h	-69.000	48h	-45.000	88h	-21.000	C8h	3.000
9h	-68.625	49h	-44.625	89h	-20.625	C9h	3.375
Ah	-68.250	4Ah	-44.250	8Ah	-20.250	CAh	3.750
Bh	-67.875	4Bh	-43.875	8Bh	-19.875	CBh	4.125
Ch	-67.500	4Ch	-43.500	8Ch	-19.500	CCh	4.500
Dh	-67.125	4Dh	-43.125	8Dh	-19.125	CDh	4.875
Eh	-66.750	4Eh	-42.750	8Eh	-18.750	CEh	5.250
Fh	-66.375	4Fh	-42.375	8Fh	-18.375	CFh	5.625
10h	-66.000	50h	-42.000	90h	-18.000	D0h	6.000
11h	-65.625	51h	-41.625	91h	-17.625	D1h	6.375
12h	-65.250	52h	-41.250	92h	-17.250	D2h	6.750
13h	-64.875	53h	-40.875	93h	-16.875	D3h	7.125
14h	-64.500	54h	-40.500	94h	-16.500	D4h	7.500
15h	-64.125	55h	-40.125	95h	-16.125	D5h	7.875
16h	-63.750	56h	-39.750	96h	-15.750	D6h	8.250
17h	-63.375	57h	-39.375	97h	-15.375	D7h	8.625
18h	-63.000	58h	-39.000	98h	-15.000	D8h	9.000
19h	-62.625	59h	-38.625	99h	-14.625	D9h	9.375
1Ah	-62.250	5Ah	-38.250	9Ah	-14.250	DAh	9.750
1Bh	-61.875	5Bh	-37.875	9Bh	-13.875	DBh	10.125
1Ch	-61.500	5Ch	-37.500	9Ch	-13.500	DCh	10.500
1Dh	-61.125	5Dh	-37.125	9Dh	-13.125	DDh	10.875
1Eh	-60.750	5Eh	-36.750	9Eh	-12.750	DEh	11.250
1Fh	-60.375	5Fh	-36.375	9Fh	-12.375	DFh	11.625
20h	-60.000	60h	-36.000	A0h	-12.000	E0h	12.000
21h	-59.625	61h	-35.625	A1h	-11.625	E1h	12.375
22h	-59.250	62h	-35.250	A2h	-11.250	E2h	12.750
23h	-58.875	63h	-34.875	A3h	-10.875	E3h	13.125
24h	-58.500	64h	-34.500	A4h	-10.500	E4h	13.500
25h	-58.125	65h	-34.125	A5h	-10.125	E5h	13.875
26h	-57.750	66h	-33.750	A6h	-9.750	E6h	14.250
27h	-57.375	67h	-33.375	A7h	-9.375	E7h	14.625
28h	-57.000	68h	-33.000	A8h	-9.000	E8h	15.000
29h	-56.625	69h	-32.625	A9h	-8.625	E9h	15.375
2Ah	-56.250	6Ah	-32.250	AAh	-8.250	EAh	15.750
2Bh	-55.875	6Bh	-31.875	ABh	-7.875	EBh	16.125
2Ch	-55.500	6Ch	-31.500	ACh	-7.500	ECh	16.500
2Dh	-55.125	6Dh	-31.125	ADh	-7.125	EDh	16.875
2Eh	-54.750	6Eh	-30.750	AEh	-6.750	EEh	17.250
2Fh	-54.375	6Fh	-30.375	AFh	-6.375	EFh	17.625
30h	-54.000	70h	-30.000	B0h	-6.000	F0h	17.625
31h	-53.625	71h	-29.625	B1h	-5.625	F1h	17.625
32h	-53.250	72h	-29.250	B2h	-5.250	F2h	17.625
33h	-52.875	73h	-28.875	B3h	-4.875	F3h	17.625
34h	-52.500	74h	-28.500	B4h	-4.500	F4h	17.625
35h	-52.125	75h	-28.125	B5h	-4.125	F5h	17.625
36h	-51.750	76h	-27.750	B6h	-3.750	F6h	17.625
37h	-51.375	77h	-27.375	B7h	-3.375	F7h	17.625
38h	-51.000	78h	-27.000	B8h	-3.000	F8h	17.625
39h	-50.625	79h	-26.625	B9h	-2.625	F9h	17.625
3Ah	-50.250	7Ah	-26.250	BAh	-2.250	FAh	17.625
3Bh	-49.875	7Bh	-25.875	BBh	-1.875	FBh	17.625
3Ch	-49.500	7Ch	-25.500	BCh	-1.500	FCh	17.625
3Dh	-49.125	7Dh	-25.125	BDh	-1.125	FDh	17.625
3Eh	-48.750	7Eh	-24.750	BEh	-0.750	FEh	17.625
3Fh	-48.375	7Fh	-24.375	BFh	-0.375	FFh	17.625

Table 36 AIF1 Output Path Digital Volume Range

**AIF1 - OUTPUT PATH HIGH PASS FILTER**

A digital high-pass filter can be enabled in the AIF1 output paths to remove DC offsets. This filter is enabled independently on each output channel using the register bits described in Table 37.

The HPF cut-off frequency for the AIF1 channels is set using AIF1ADC1\_HPF\_CUT.

In hi-fi mode, the high pass filter is optimised for removing DC offsets without degrading the bass response and has a cut-off frequency of 3.7Hz when the sample rate (fs) = 44.1kHz.

In voice modes, the high pass filter is optimised for voice communication; it is recommended to set the cut-off frequency below 300Hz.

Note that the cut-off frequencies scale with the AIF1 sample rate. (The AIF1 sample rate is set using the AIF1\_SR register, as described in the "Clocking and Sample Rates" section.) See Table 38 for the HPF cut-off frequencies at all supported sample rates.

REGISTER ADDRESS	BIT	LABEL	DEFAULT	DESCRIPTION
R1040 (0410h) AIF1 ADC1 Filters	14:13	AIF1ADC1_HPF_CUT [1:0]	00	AIF1ADC output path Digital HPF cut-off frequency (fc) 00 = Hi-fi mode (fc = 4Hz at fs = 48kHz) 01 = Voice mode 1 (fc = 64Hz at fs = 8kHz) 10 = Voice mode 2 (fc = 130Hz at fs = 8kHz) 11 = Voice mode 3 (fc = 267Hz at fs = 8kHz)
	12	AIF1ADC1L_HPF	0	AIF1ADC (Left) output path Digital HPF Enable 0 = Disabled 1 = Enabled
	11	AIF1ADC1R_HPF	0	AIF1ADC (Right) output path Digital HPF Enable 0 = Disabled 1 = Enabled

**Table 37 AIF1 Output Path High Pass Filter**

Sample Frequency (kHz)	Cut-Off Frequency (Hz) for given value of AIF1ADC1_HPF_CUT or AIF2ADC_HPF_CUT			
	00	01	10	11
8.000	0.7	64	130	267
11.025	0.9	88	178	367
16.000	1.3	127	258	532
22.050	1.9	175	354	733
24.000	2.0	190	386	798
32.000	2.7	253	514	1063
44.100	3.7	348	707	1464
48.000	4.0	379	770	1594
88.200	7.4	696	1414	2928
96.000	8.0	758	1540	3188

**Table 38 AIF1 Output Path High Pass Filter Cut-Off Frequencies**



**AIF1 - INPUT PATH VOLUME CONTROL**

A digital volume control is provided on the AIF1 input signal paths, allowing attenuation in the range -71.625dB to 0dB in 0.375dB steps. The level of attenuation for an eight-bit code X is given by:

$$0.375 \times (X-192) \text{ dB for } 1 \leq X \leq 192; \quad \text{MUTE for } X = 0 \quad 0\text{dB for } 192 \leq X \leq 255$$

The AIF1DAC1\_VU bits control the loading of digital volume control data. When this bit is set to 0, the AIF1DAC1L\_VOL and AIF1DAC1R\_VOL control data will be loaded into the respective control register, but will not actually change the digital gain setting.

The AIF1DAC1L\_VOL and AIF1DAC1R\_VOL gain settings are updated when a 1 is written to AIF1DAC1\_VU. This makes it possible to update the gain of left and right channels simultaneously.

Note that a digital gain function is also available at the audio interface input, to boost the DAC volume when a small signal is received on DACDAT1. See "Digital Audio Interface Control" for further details.

Digital volume control is also possible within the digital core functions, after the audio signal has passed through the DAC output digital mixers or AIF2 output digital mixers. See "Digital Mixing" for further details.

REGISTER ADDRESS	BIT	LABEL	DEFAULT	DESCRIPTION
R1026 (0402h) AIF1 DAC1 Left Volume	8	AIF1DAC1_VU	N/A	AIF1DAC input path Volume Update Writing a 1 to this bit will cause the AIF1DAC1L and AIF1DAC1R volume to be updated simultaneously
	7:0	AIF1DAC1L_VOL [7:0]	C0h (0dB)	AIF1DAC (Left) input path Digital Volume 00h = MUTE 01h = -71.625dB ... (0.375dB steps) C0h = 0dB FFh = 0dB (See Table 40 for volume range)
R1027 (0403h) AIF1 DAC1 Right Volume	8	AIF1DAC1_VU	N/A	AIF1DAC input path Volume Update Writing a 1 to this bit will cause the AIF1DAC1L and AIF1DAC1R volume to be updated simultaneously
	7:0	AIF1DAC1R_VOL [7:0]	C0h (0dB)	AIF1DAC (Right) input path Digital Volume 00h = MUTE 01h = -71.625dB ... (0.375dB steps) C0h = 0dB FFh = 0dB (See Table 40 for volume range)

**Table 39 AIF1 Input Path Volume Control**

AIF1/AIF2 Input Volume	Volume (dB)	AIF1/AIF2 Input Volume	Volume (dB)	AIF1/AIF2 Input Volume	Volume (dB)	AIF1/AIF2 Input Volume	Volume (dB)
0h	MUTE	40h	-48.000	80h	-24.000	C0h	0.000
1h	-71.625	41h	-47.625	81h	-23.625	C1h	0.000
2h	-71.250	42h	-47.250	82h	-23.250	C2h	0.000
3h	-70.875	43h	-46.875	83h	-22.875	C3h	0.000
4h	-70.500	44h	-46.500	84h	-22.500	C4h	0.000
5h	-70.125	45h	-46.125	85h	-22.125	C5h	0.000
6h	-69.750	46h	-45.750	86h	-21.750	C6h	0.000
7h	-69.375	47h	-45.375	87h	-21.375	C7h	0.000
8h	-69.000	48h	-45.000	88h	-21.000	C8h	0.000
9h	-68.625	49h	-44.625	89h	-20.625	C9h	0.000
Ah	-68.250	4Ah	-44.250	8Ah	-20.250	CAh	0.000
Bh	-67.875	4Bh	-43.875	8Bh	-19.875	CBh	0.000
Ch	-67.500	4Ch	-43.500	8Ch	-19.500	CCh	0.000
Dh	-67.125	4Dh	-43.125	8Dh	-19.125	CDh	0.000
Eh	-66.750	4Eh	-42.750	8Eh	-18.750	CEh	0.000
Fh	-66.375	4Fh	-42.375	8Fh	-18.375	CFh	0.000
10h	-66.000	50h	-42.000	90h	-18.000	D0h	0.000
11h	-65.625	51h	-41.625	91h	-17.625	D1h	0.000
12h	-65.250	52h	-41.250	92h	-17.250	D2h	0.000
13h	-64.875	53h	-40.875	93h	-16.875	D3h	0.000
14h	-64.500	54h	-40.500	94h	-16.500	D4h	0.000
15h	-64.125	55h	-40.125	95h	-16.125	D5h	0.000
16h	-63.750	56h	-39.750	96h	-15.750	D6h	0.000
17h	-63.375	57h	-39.375	97h	-15.375	D7h	0.000
18h	-63.000	58h	-39.000	98h	-15.000	D8h	0.000
19h	-62.625	59h	-38.625	99h	-14.625	D9h	0.000
1Ah	-62.250	5Ah	-38.250	9Ah	-14.250	DAh	0.000
1Bh	-61.875	5Bh	-37.875	9Bh	-13.875	DBh	0.000
1Ch	-61.500	5Ch	-37.500	9Ch	-13.500	DCh	0.000
1Dh	-61.125	5Dh	-37.125	9Dh	-13.125	DDh	0.000
1Eh	-60.750	5Eh	-36.750	9Eh	-12.750	DEh	0.000
1Fh	-60.375	5Fh	-36.375	9Fh	-12.375	DFh	0.000
20h	-60.000	60h	-36.000	A0h	-12.000	E0h	0.000
21h	-59.625	61h	-35.625	A1h	-11.625	E1h	0.000
22h	-59.250	62h	-35.250	A2h	-11.250	E2h	0.000
23h	-58.875	63h	-34.875	A3h	-10.875	E3h	0.000
24h	-58.500	64h	-34.500	A4h	-10.500	E4h	0.000
25h	-58.125	65h	-34.125	A5h	-10.125	E5h	0.000
26h	-57.750	66h	-33.750	A6h	-9.750	E6h	0.000
27h	-57.375	67h	-33.375	A7h	-9.375	E7h	0.000
28h	-57.000	68h	-33.000	A8h	-9.000	E8h	0.000
29h	-56.625	69h	-32.625	A9h	-8.625	E9h	0.000
2Ah	-56.250	6Ah	-32.250	AAh	-8.250	EAh	0.000
2Bh	-55.875	6Bh	-31.875	ABh	-7.875	EBh	0.000
2Ch	-55.500	6Ch	-31.500	ACh	-7.500	ECh	0.000
2Dh	-55.125	6Dh	-31.125	ADh	-7.125	EDh	0.000
2Eh	-54.750	6Eh	-30.750	A Eh	-6.750	EEh	0.000
2Fh	-54.375	6Fh	-30.375	AFh	-6.375	EFh	0.000
30h	-54.000	70h	-30.000	B0h	-6.000	F0h	0.000
31h	-53.625	71h	-29.625	B1h	-5.625	F1h	0.000
32h	-53.250	72h	-29.250	B2h	-5.250	F2h	0.000
33h	-52.875	73h	-28.875	B3h	-4.875	F3h	0.000
34h	-52.500	74h	-28.500	B4h	-4.500	F4h	0.000
35h	-52.125	75h	-28.125	B5h	-4.125	F5h	0.000
36h	-51.750	76h	-27.750	B6h	-3.750	F6h	0.000
37h	-51.375	77h	-27.375	B7h	-3.375	F7h	0.000
38h	-51.000	78h	-27.000	B8h	-3.000	F8h	0.000
39h	-50.625	79h	-26.625	B9h	-2.625	F9h	0.000
3Ah	-50.250	7Ah	-26.250	BAh	-2.250	FAh	0.000
3Bh	-49.875	7Bh	-25.875	BBh	-1.875	FBh	0.000
3Ch	-49.500	7Ch	-25.500	BCh	-1.500	FCh	0.000
3Dh	-49.125	7Dh	-25.125	BDh	-1.125	FDh	0.000
3Eh	-48.750	7Eh	-24.750	BEh	-0.750	FEh	0.000
3Fh	-48.375	7Fh	-24.375	BFh	-0.375	FFh	0.000

Table 40 AIF1 Input Path Digital Volume Range

### AIF1 - INPUT PATH SOFT MUTE CONTROL

The WM1811A provides a soft mute function for the AIF1 input paths. When the mute function is selected, the WM1811A gradually attenuates the associated signal paths until the path is entirely muted.

When the mute function is de-selected, the gain will either return instantly to the digital gain setting, or will gradually ramp back to the digital gain setting, depending on the AIF1DAC1\_UNMUTE\_RAMP register field.

The mute and un-mute ramp rate is selectable between two different rates.

The AIF1 input paths are soft-muted by default. To play back an audio signal, the soft-mute must first be de-selected by setting AIF1DAC1\_MUTE = 0.

The soft un-mute would typically be used during playback of audio data so that when the Mute is subsequently disabled, a smooth transition is scheduled to the previous volume level and pop noise is avoided. This is desirable when resuming playback after pausing during a track.

The soft un-mute would typically not be required when un-muting at the start of a music file, in order that the first part of the music track is not attenuated. The instant un-mute behaviour is desirable in this case, when starting playback of a new track. See "Digital Volume Soft Mute and Soft Un-Mute" (Figure 19) for an illustration of the soft mute function.

REGISTER ADDRESS	BIT	LABEL	DEFAULT	DESCRIPTION
R1056 (0420h) AIF1 DAC1 Filters (1)	9	AIF1DAC1_MUTE	1	AIF1DAC input path Soft Mute Control 0 = Un-mute 1 = Mute
	5	AIF1DAC1_MUTERATE	0	AIF1DAC input path Soft Mute Ramp Rate 0 = Fast ramp (fs/2, maximum ramp time is 10.7ms at fs=48k) 1 = Slow ramp (fs/32, maximum ramp time is 171ms at fs=48k) (Note: ramp rate scales with sample rate.)
	4	AIF1DAC1_UNMUTE_RAMP	0	AIF1DAC input path Unmute Ramp select 0 = Unmuting the AIF1DAC path (AIF1DAC1_MUTE=0) will immediately apply the AIF1DAC1L_VOL and AIF1DAC1R_VOL settings. 1 = Unmuting the AIF1DAC path (AIF1DAC1_MUTE=0) will cause a gradual volume ramp up to the AIF1DAC1L_VOL and AIF1DAC1R_VOL settings.

**Table 41 AIF1 Input Path Soft Mute Control**

### AIF1 - INPUT PATH NOISE GATE CONTROL

The WM1811A provides a digital noise gate function for the AIF1 input paths. The noise gate ensures best noise performance when the signal path is idle. When the noise gate is enabled, and the signal level is below the noise gate threshold, then the noise gate is activated, causing the signal path to be muted.

The AIF1 input path noise gate is enabled using the AIF1DAC1\_NG\_ENA register.

The noise gate threshold (the signal level below which the noise gate is activated) is set using AIF1DAC1\_NG\_THR.

To prevent erroneous triggering, a time delay is applied before the gate is activated; the signal path is only muted when the signal level stays below the threshold for longer than 'hold time', determined by the AIF1DAC1\_NG\_HLD register.

When the noise gate is activated, the WM1811A gradually attenuates the AIF1 input signal paths until each is entirely muted. When the signal level increases, and the noise gate is de-activated, the gain will return to the AIF1DAC1L\_VOL and AIF1DAC1R\_VOL digital gain settings. The un-mute behaviour can be immediate or gradual; this is determined by the AIF1DAC1\_MUTERATE and AIF1DAC1\_UNMUTE\_RAMP registers described in Table 41.

REGISTER ADDRESS	BIT	LABEL	DEFAULT	DESCRIPTION
R1072 (0430h) AIF1 DAC1 Noise Gate	6:5	AIF1DAC1_ NG_HLD [1:0]	11	AIF1DAC input path Noise Gate Hold Time (delay before noise gate is activated) 00 = 30ms 01 = 125ms 10 = 250ms 11 = 500ms
	3:1	AIF1DAC1_ NG_THR [2:0]	100	AIF1DAC input path Noise Gate Threshold 000 = -60dB 001 = -66dB 010 = -72dB 011 = -78dB 100 = -84dB 101 = -90dB 110 = -96dB 111 = -102dB
	0	AIF1DAC1_ NG_ENA	0	AIF1DAC input path Noise Gate Enable 0 = Disabled 1 = Enabled

Table 42 AIF1 Input Path Noise Gate Control

### AIF1 - INPUT PATH MONO MIX CONTROL

A digital mono mix can be selected on the AIF1 input channels. The mono mix is generated as the sum of the Left and Right AIF channel data. When the mono mix function is enabled, the combined mono signal is applied to the Left channel and the Right channel of the AIF1 signal processing and digital mixing paths. To prevent clipping, 6dB attenuation is applied to the mono mix.

REGISTER ADDRESS	BIT	LABEL	DEFAULT	DESCRIPTION
R1056 (0420h) AIF1 DAC1 Filters (1)	7	AIF1DAC1_ MONO	0	AIF1DAC input path Mono Mix Control 0 = Disabled 1 = Enabled

Table 43 AIF1 Input Path Mono Mix Control

### AIF2 - OUTPUT PATH VOLUME CONTROL

A digital volume control is provided on the AIF2 output signal paths, allowing attenuation in the range -71.625dB to +17.625dB in 0.375dB steps. The level of attenuation for an eight-bit code X is given by:

$$0.375 \times (X-192) \text{ dB for } 1 \leq X \leq 239; \quad \text{MUTE for } X = 0 \quad +17.625\text{dB for } 239 \leq X \leq 255$$

The AIF2ADC\_VU bits control the loading of digital volume control data. When this bit is set to 0, the AIF2ADCL\_VOL and AIF2ADCR\_VOL control data will be loaded into the respective control register, but will not actually change the digital gain setting.

The AIF2ADCL\_VOL and AIF2ADCR\_VOL gain settings are updated when a 1 is written to AIF2ADC\_VU. This makes it possible to update the gain of left and right channels simultaneously.

Digital volume control is also possible within the digital core functions, after the audio signal has passed through the AIF2 output digital mixers. See "Digital Mixing" for further details.

REGISTER ADDRESS	BIT	LABEL	DEFAULT	DESCRIPTION
R1280 (0500h) AIF2 ADC Left Volume	8	AIF2ADC_VU	N/A	AIF2ADC output path Volume Update Writing a 1 to this bit will cause the AIF2ADCL and AIF2ADCR volume to be updated simultaneously
	7:0	AIF2ADCL_VOL [7:0]	C0h (0dB)	AIF2ADC (Left) output path Digital Volume 00h = MUTE 01h = -71.625dB ... (0.375dB steps) EFh = +17.625dB (See Table 36 for volume range)
R1281 (0501h) AIF2 ADC Right Volume	8	AIF2ADC_VU	N/A	AIF2ADC output path Volume Update Writing a 1 to this bit will cause the AIF2ADCL and AIF2ADCR volume to be updated simultaneously
	7:0	AIF2ADCR_VOL [7:0]	C0h (0dB)	AIF2ADC (Right) output path Digital Volume 00h = MUTE 01h = -71.625dB ... (0.375dB steps) EFh = +17.625dB (See Table 36 for volume range)

Table 44 AIF2 Output Path Volume Control

#### AIF2 - OUTPUT PATH HIGH PASS FILTER

A digital high-pass filter can be enabled in the AIF2 output paths to remove DC offsets. This filter is enabled independently on each output channel using the register bits described in Table 45.

The HPF cut-off frequency for the AIF2 channels is set using AIF2ADC\_HPF\_CUT.

In hi-fi mode, the high pass filter is optimised for removing DC offsets without degrading the bass response and has a cut-off frequency of 3.7Hz when the sample rate ( $f_s$ ) = 44.1kHz.

In voice modes, the high pass filter is optimised for voice communication; it is recommended to set the cut-off frequency below 300Hz.

Note that the cut-off frequencies scale with the AIF2 sample rate. (The AIF2 sample rate is set using the AIF2\_SR register, as described in the "Clocking and Sample Rates" section.) See Table 38 for the HPF cut-off frequencies at all supported sample rates.

REGISTER ADDRESS	BIT	LABEL	DEFAULT	DESCRIPTION
R1296(0510h) AIF2ADC Filters	14:13	AIF2ADC_HPF_CUT [1:0]	00	AIF2ADC output path Digital HPF Cut-Off Frequency (fc) 00 = Hi-fi mode (fc = 4Hz at $f_s$ = 48kHz) 01 = Voice mode 1 (fc = 127Hz at $f_s$ = 8kHz) 10 = Voice mode 2 (fc = 130Hz at $f_s$ = 8kHz) 11 = Voice mode 3 (fc = 267Hz at $f_s$ = 8kHz)
	12	AIF2ADCL_HPF	0	AIF2ADC (Left) output path Digital HPF Enable 0 = Disabled 1 = Enabled
	11	AIF2ADCR_HPF	0	AIF2ADC (Right) output path Digital HPF Enable 0 = Disabled 1 = Enabled

Table 45 AIF2 Output Path High Pass Filter

**AIF2 - INPUT PATH VOLUME CONTROL**

A digital volume control is provided on the AIF2 input signal paths, allowing attenuation in the range -71.625dB to 0dB in 0.375dB steps. The level of attenuation for an eight-bit code X is given by:

$$0.375 \times (X-192) \text{ dB for } 1 \leq X \leq 192; \quad \text{MUTE for } X = 0 \quad 0\text{dB for } 192 \leq X \leq 255$$

The AIF2DAC\_VU bits control the loading of digital volume control data. When this bit is set to 0, the AIF2DACL\_VOL and AIF2DACR\_VOL control data will be loaded into the respective control register, but will not actually change the digital gain setting.

The AIF2DACL\_VOL and AIF2DACR\_VOL gain settings are updated when a 1 is written to AIF2DAC\_VU. This makes it possible to update the gain of left and right channels simultaneously.

Note that a digital gain function is also available at the audio interface input, to boost the DAC volume when a small signal is received on DACDAT2. See "Digital Audio Interface Control" for further details.

Digital volume control is also possible within the digital core functions, after the audio signal has passed through the DAC output digital mixers or AIF2 output digital mixers. See "Digital Mixing" for further details.

REGISTER ADDRESS	BIT	LABEL	DEFAULT	DESCRIPTION
R1282 (0502h) AIF2 DAC Left Volume	8	AIF2DAC_VU	N/A	AIF2DAC input path Volume Update Writing a 1 to this bit will cause the AIF2DACL and AIF2DACR volume to be updated simultaneously
	7:0	AIF2DACL_VOL [7:0]	C0h (0dB)	AIF2DAC (Left) input path Digital Volume 00h = MUTE 01h = -71.625dB ... (0.375dB steps) C0h = 0dB FFh = 0dB (See Table 40 for volume range)
R1283 (0503h) AIF2 DAC Right Volume	8	AIF2DAC_VU	N/A	AIF2DAC input path Volume Update Writing a 1 to this bit will cause the AIF2DACL and AIF2DACR volume to be updated simultaneously
	7:0	AIF2DACR_VOL [7:0]	C0h (0dB)	AIF2DAC (Right) input path Digital Volume 00h = MUTE 01h = -71.625dB ... (0.375dB steps) C0h = 0dB FFh = 0dB (See Table 40 for volume range)

**Table 46 AIF2 Input Path Volume Control**

### AIF2 - INPUT PATH SOFT MUTE CONTROL

The WM1811A provides a soft mute function for the AIF2input paths. When the mute function is selected, the WM1811A gradually attenuates the associated signal paths until the path is entirely muted.

When the mute function is de-selected, the gain will either return instantly to the digital gain setting, or will gradually ramp back to the digital gain setting, depending on the AIF2DAC\_UNMUTE\_RAMP register field.

The mute and un-mute ramp rate is selectable between two different rates.

The AIF2input paths are soft-muted by default. To play back an audio signal, the soft-mute must first be de-selected by setting AIF2DAC\_MUTE = 0.

The soft un-mute would typically be used during playback of audio data so that when the Mute is subsequently disabled, a smooth transition is scheduled to the previous volume level and pop noise is avoided. This is desirable when resuming playback after pausing during a track.

The soft un-mute would typically not be required when un-muting at the start of a music file, in order that the first part of the music track is not attenuated. The instant un-mute behaviour is desirable in this case, when starting playback of a new track. See "Digital Volume Soft Mute and Soft Un-Mute" (Figure 19) for an illustration of the soft mute function.

REGISTER ADDRESS	BIT	LABEL	DEFAULT	DESCRIPTION
R1312 (0520h) AIF2 DAC Filters (1)	9	AIF2DAC_MUTE	1	AIF2DAC input path Soft Mute Control 0 = Un-mute 1 = Mute
	5	AIF2DAC_MUTERATE	0	AIF2DAC input path Soft Mute Ramp Rate 0 = Fast ramp (fs/2, maximum ramp time is 10.7ms at fs=48k) 1 = Slow ramp (fs/32, maximum ramp time is 171ms at fs=48k) (Note: ramp rate scales with sample rate.)
	4	AIF2DAC_UNMUTE_RAMP	0	AIF2DAC input path Unmute Ramp select 0 = Unmuting the AIF2DAC path (AIF2DAC_MUTE=0) will immediately apply the AIF2DACL_VOL and AIF2DACR_VOL settings. 1 = Unmuting the AIF2DAC path (AIF2DAC_MUTE=0) will cause a gradual volume ramp up to the AIF2DACL_VOL and AIF2DACR_VOL settings.

Table 47 AIF2 Input Path Soft Mute Control

**AIF2 - INPUT PATH NOISE GATE CONTROL**

The WM1811A provides a digital noise gate function for the AIF2 input paths. The noise gate ensures best noise performance when the signal path is idle. When the noise gate is enabled, and the signal level is below the noise gate threshold, then the noise gate is activated, causing the signal path to be muted.

The AIF2 input path noise gate is enabled using the AIF2DAC\_NG\_ENA register.

The noise gate threshold (the signal level below which the noise gate is activated) is set using AIF2DAC\_NG\_THR.

To prevent erroneous triggering, a time delay is applied before the gate is activated; the signal path is only muted when the signal level stays below the threshold for longer than 'hold time', determined by the AIF2DAC\_NG\_HLD register.

When the noise gate is activated, the WM1811A gradually attenuates the AIF2 input signal paths until each is entirely muted. When the signal level increases, and the noise gate is de-activated, the gain will return to the AIF2DACL\_VOL and AIF2DACR\_VOL digital gain settings. The un-mute behaviour can be immediate or gradual; this is determined by the AIF2DAC\_MUTERATE and AIF2DAC\_UNMUTE\_RAMP registers described in Table 47.

REGISTER ADDRESS	BIT	LABEL	DEFAULT	DESCRIPTION
R1328 (0530h) AIF2 DAC Noise Gate	6:5	AIF2DAC_NG_HLD [1:0]	11	AIF2DAC input path Noise Gate Hold Time (delay before noise gate is activated) 00 = 30ms 01 = 125ms 10 = 250ms 11 = 500ms
	3:1	AIF2DAC_NG_THR [2:0]	100	AIF2DAC input path Noise Gate Threshold 000 = -60dB 001 = -66dB 010 = -72dB 011 = -78dB 100 = -84dB 101 = -90dB 110 = -96dB 111 = -102dB
	0	AIF2DAC_NG_ENA	0	AIF2DAC input path Noise Gate Enable 0 = Disabled 1 = Enabled

**Table 48 AIF2 Input Path Noise Gate Control**

**AIF2- INPUT PATH MONO MIX CONTROL**

A digital mono mix can be selected on the AIF2 input channels. The mono mix is generated as the sum of the Left and Right AIF channel data. When the mono mix function is enabled, the combined mono signal is applied to the Left channel and the Right channel of the AIF2 signal processing and digital mixing paths. To prevent clipping, 6dB attenuation is applied to the mono mix.

REGISTER ADDRESS	BIT	LABEL	DEFAULT	DESCRIPTION
R1312(0520h) AIF2DAC Filters (1)	7	AIF2DAC_MONO	0	AIF2DAC input path Mono Mix Control 0 = Disabled 1 = Enabled

**Table 49 AIF2 Input Path Mono Mix Control**



## DIGITAL TO ANALOGUE CONVERTER (DAC)

The WM1811A DACs receive digital input data from the DAC mixers - see "Digital Mixing". The digital audio data is converted to oversampled bit streams in the on-chip, true 24-bit digital interpolation filters. The bitstream data enters two multi-bit, sigma-delta DACs, which convert them to high quality analogue audio signals. The multi-bit DAC architecture reduces high frequency noise and sensitivity to clock jitter. It also uses a Dynamic Element Matching technique for high linearity and low distortion.

A high performance mode of DAC operation can be selected by setting the DAC\_OSR128 bit - see "Clocking and Sample Rates" for details.

The analogue outputs from the DACs can be mixed with analogue line/mic inputs using the line output mixers MIXOUTL / MIXOUTR and the speaker output mixers SPKMIXL / SPKMIXR.

The DACs are enabled using the register bits defined in Table 50.

Note that the DAC clock must be enabled whenever the DACs are enabled.

REGISTER ADDRESS	BIT	LABEL	DEFAULT	DESCRIPTION
R5 (0005h) Power Management (5)	1	DAC1L_EN A	0	Left DAC Enable 0 = Disabled 1 = Enabled
	0	DAC1R_EN A	0	Right DAC Enable 0 = Disabled 1 = Enabled

**Table 50 DAC Enable Control**

### DAC CLOCKING CONTROL

Clocking for the DACs is derived from SYSCLK. The required clock is enabled when the SYDSPCLK\_ENA register is set.

The DAC clock rate is configured automatically, according to the AIFn\_SR, AIFnCLK\_RATE and DAC\_OSR128 registers. (See "Clocking and Sample Rates" for further details of the system clocks and control registers.)

When AIF1CLK is selected as the SYSCLK source (SYSCLK\_SRC = 0), then the DAC clocking is controlled by the AIF1\_SR and AIF1CLK\_RATE registers.

When AIF2CLK is selected as the SYSCLK source (SYSCLK\_SRC = 1), then the DAC clocking is controlled by the AIF2\_SR and AIF2CLK\_RATE registers.

The supported DAC clocking configurations are described in Table 51 (for DAC\_OSR128=0) and Table 52 (for DAC\_OSR128=1). Under default conditions, the DAC\_OSR128 bit is not set.

SAMPLE RATE (kHz)	SYSCLK RATE (AIFnCLK / fs ratio)							
	128	192	256	384	512	768	1024	1536
8			✓	✓	✓	✓	✓	✓
11.025		Note 1	✓	✓	✓	✓	✓	
12		Note 1	✓	✓	✓	✓	✓	
16	Note 1	Note 1	✓	✓	✓	✓		
22.05	Note 1	Note 1	✓	✓	✓			
24	Note 1	Note 1	✓	✓	✓			
32	Note 1	Note 1	✓	✓				
44.1	Note 1	Note 1	✓					
48	Note 1	Note 1	✓					
88.2	Note 1							
96	Note 1							

When DAC\_OSR128=0, DAC operation is only supported for the configurations indicated above

Table 51 DAC Clocking - DAC\_OSR128 = 0 (Default)

SAMPLE RATE (kHz)	SYSCLK RATE (AIFnCLK / fs ratio)							
	128	192	256	384	512	768	1024	1536
8					✓	✓	✓	✓
11.025				✓	✓	✓	✓	
12				✓	✓	✓	✓	
16			✓	✓	✓	✓		
22.05		Note 1	✓	✓	✓			
24		Note 1	✓	✓	✓			
32	Note 1	Note 1	✓	✓				
44.1	Note 1	Note 1	✓					
48	Note 1	Note 1	✓					
88.2	Note 1							
96	Note 1							

When DAC\_OSR128=1, DAC operation is only supported for the configurations indicated above

Table 52 DAC Clocking - DAC\_OSR128 = 1

Note 1 - These clocking rates are only supported for 'simple' DAC-only playback modes, under the following conditions:

- AIF input is enabled on a single interface (AIF1 or AIF2) only, or is enabled on AIF1 and AIF2 simultaneously provided AIF1 and AIF2 are synchronised (ie. AIF1CLK\_SRC = AIF2CLK\_SRC)
- All AIF output paths are disabled
- All DSP functions (ReTune™ Mobile Parametric Equaliser, 3D stereo expansion and Dynamic Range Control) are disabled

The clocking requirements in Table 51 and Table 52 are only applicable to the AIFnCLK that is selected as the SYSCLK source. Note that both clocks (AIF1CLK and AIF2CLK) must satisfy the requirements noted in the "Clocking and Sample Rates" section.

The applicable clocks (SYSCLK, and AIF1CLK or AIF2CLK) must be present and enabled when using the Digital to Analogue Converters (DACs).

Note that the presence of a suitable clock is automatically detected by the WM1811A; if the clock signal is absent, then any speaker or earpiece output driver(s) associated with the DAC signal paths will be disabled. (This is applicable to the SPKOUTL, SPKOUTR and HPOUT2 outputs only, whenever one or more DAC is routed to these output drivers.)

### ANALOGUE OUTPUT SIGNAL PATH

The WM1811A output routing and mixers provide a high degree of flexibility, allowing operation of many simultaneous signal paths through the device to a variety of analogue outputs. The outputs include a ground referenced headphone driver, two Class D loudspeaker drivers, an ear speaker driver and four highly flexible line drivers. See “Analogue Outputs” for further details of these outputs.

The WM1811A output signal paths and control registers are illustrated in Figure 27.

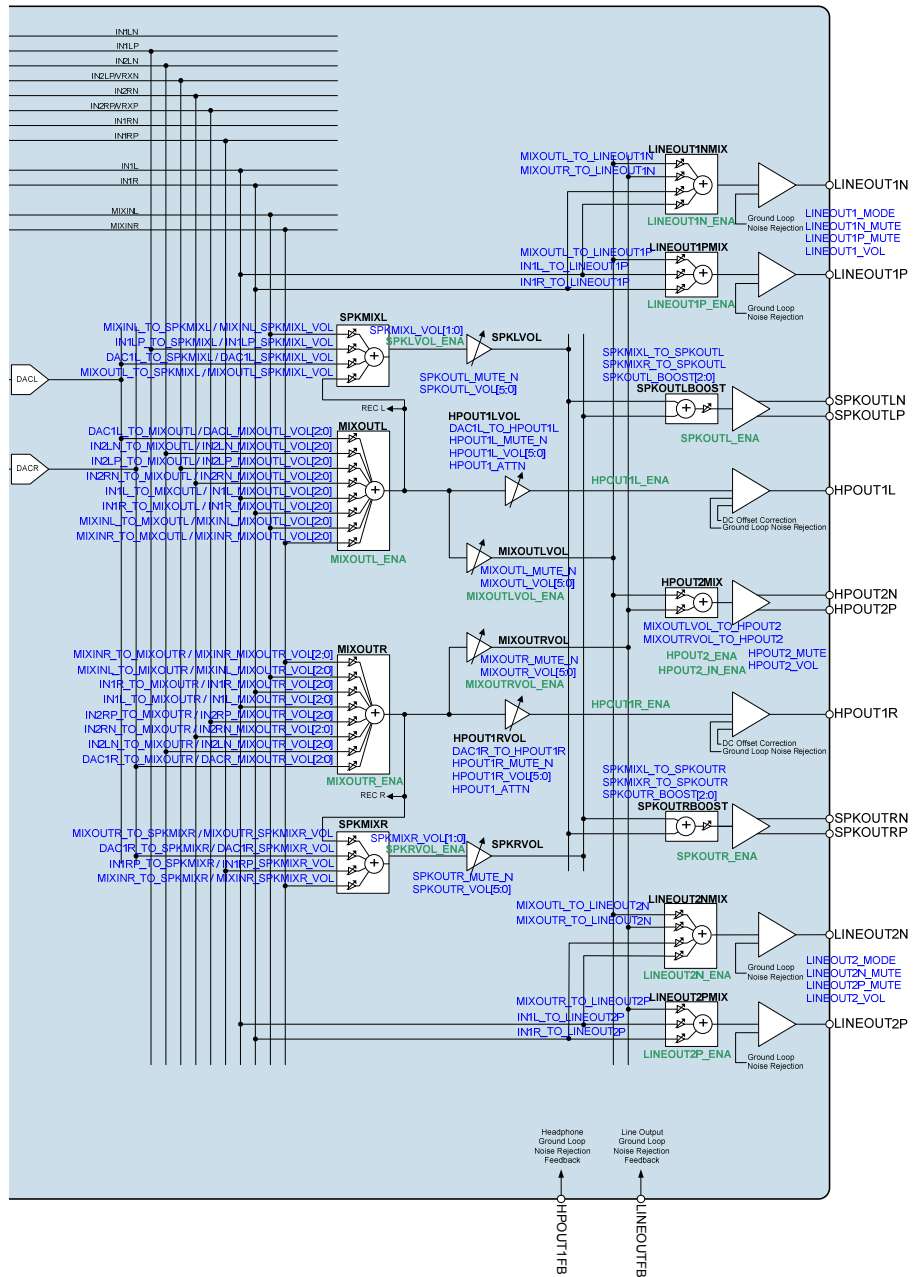

Figure 27 Control Registers for Output Signal Path

**OUTPUT SIGNAL PATHS ENABLE**

The output mixers and drivers can be independently enabled and disabled as described in Table 53.

The supply rails for headphone outputs HPOUT1L and HPOUT1R are generated using an integrated dual-mode Charge Pump, which must be enabled whenever the headphone outputs are used. See the "Charge Pump" section for details on enabling and configuring this circuit.

Note that the Headphone Outputs are also controlled by fields located within Register R96, which provide suppression of pops & clicks when enabling and disabling the HPOUT1L and HPOUT1R signal paths. These registers are described in the following "Headphone Signal Paths Enable" section.

For normal operation of the output signal paths, the reference voltage VMID and the bias current must also be enabled. See "Reference Voltages and Master Bias" for details of the associated controls VMID\_SEL and BIAS\_ENA.

REGISTER ADDRESS	BIT	LABEL	DEFAULT	DESCRIPTION
R1 (0001h) Power Management (1)	13	SPKOUTR_ENA	0	SPKMIXR Mixer, SPKRVOL PGA and SPKOUTR Output Enable 0 = Disabled 1 = Enabled
	12	SPKOUTL_ENA	0	SPKMIXL Mixer, SPKLVOL PGA and SPKOUTL Output Enable 0 = Disabled 1 = Enabled
	11	HPOUT2_ENA	0	HPOUT2 Output Stage Enable 0 = Disabled 1 = Enabled
	9	HPOUT1L_ENA	0	Enables HPOUT1L input stage 0 = Disabled 1 = Enabled For normal operation, this bit should be set as the first step of the HPOUT1L Enable sequence.
	8	HPOUT1R_ENA	0	Enables HPOUT1R input stage 0 = Disabled 1 = Enabled For normal operation, this bit should be set as the first step of the HPOUT1R Enable sequence.
R3 (0003h) Power Management (3)	13	LINEOUT1N_ENA	0	LINEOUT1N Line Out and LINEOUT1NMIX Enable 0 = Disabled 1 = Enabled
	12	LINEOUT1P_ENA	0	LINEOUT1P Line Out and LINEOUT1PMIX Enable 0 = Disabled 1 = Enabled
	11	LINEOUT2N_ENA	0	LINEOUT2N Line Out and LINEOUT2NMIX Enable 0 = Disabled 1 = Enabled
	10	LINEOUT2P_ENA	0	LINEOUT2P Line Out and LINEOUT2PMIX Enable 0 = Disabled 1 = Enabled

REGISTER ADDRESS	BIT	LABEL	DEFAULT	DESCRIPTION
	9	SPKRVOL_ENA	0	SPKMIXR Mixer and SPKRVOL PGA Enable 0 = Disabled 1 = Enabled Note that SPKMIXR and SPKRVOL are also enabled when SPKOUTR_ENA is set.
	8	SPKLVOL_ENA	0	SPKMIXL Mixer and SPKLVOL PGA Enable 0 = Disabled 1 = Enabled Note that SPKMIXL and SPKLVOL are also enabled when SPKOUTL_ENA is set.
	7	MIXOUTLVOL_ENA	0	MIXOUTL Left Volume Control Enable 0 = Disabled 1 = Enabled
	6	MIXOUTRVOL_ENA	0	MIXOUTR Right Volume Control Enable 0 = Disabled 1 = Enabled
	5	MIXOUTL_ENA	0	MIXOUTL Left Output Mixer Enable 0 = Disabled 1 = Enabled
	4	MIXOUTR_ENA	0	MIXOUTR Right Output Mixer Enable 0 = Disabled 1 = Enabled
R56 (0038h) AntiPOP (1)	6	HPOUT2_IN_ENA	0	HPOUT2MIX Mixer and Input Stage Enable 0 = Disabled 1 = Enabled

Table 53 Output Signal Paths Enable

### HEADPHONE SIGNAL PATHS ENABLE

The HPOUT1L and HPOUT1R output paths can be actively discharged to AGND through internal resistors if desired. This is desirable at start-up in order to achieve a known output stage condition prior to enabling the VMID reference voltage. This is also desirable in shutdown to prevent the external connections from being affected by the internal circuits. The HPOUT1L and HPOUT1R outputs are shorted to AGND by default; the short circuit is removed on each of these paths by setting the applicable fields HPOUT1L\_RMV\_SHORT or HPOUT1R\_RMV\_SHORT.

The ground-referenced Headphone output drivers are designed to suppress pops and clicks when enabled or disabled. However, it is necessary to control the drivers in accordance with a defined sequence in start-up and shutdown to achieve the pop suppression. It is also necessary to schedule the DC Servo offset correction at the appropriate point in the sequence (see "DC Servo").

Table 54 and Table 55 describe the recommended sequences for enabling and disabling these output drivers.

SEQUENCE	HEADPHONE ENABLE
Step 1	Write 0x0003 to Register R258 (0102h) Write 0x0C07 to Register R86 (0056h) Write 0x007E to Register R93 (005Dh) Write 0x0000 to Register R94 (005Eh) Write 0x0000 to Register R258 (0102h)  (These register writes must be executed in the order noted above.)
Step 2	HPOUT1L_ENA = 1 HPOUT1R_ENA = 1
Step 3	20 $\mu$ s delay
Step 4	HPOUT1L_DLY = 1 HPOUT1R_DLY = 1
Step 5	Run the DC Servo in Start-Up mode: Write 0x0033 to R84 (0054h)
Step 6	Wait until offset correction is complete: This is indicated when DCS_STARTUP_COMPLETE=11b
Step 7	Read back DCS_DAC_WR_VAL_0 and DCS_DAC_WR_VAL_1 from Register R89 (0059h)
Step 8	Subtract 0x09 from DCS_DAC_WR_VAL_0 Subtract 0x05 from DCS_DAC_WR_VAL_1
Step 9	Write the updated values of DCS_DAC_WR_VAL_0 and DCS_DAC_WR_VAL_1 to Register R89 (0059h)
Step 10	Run the DC Servo in DAC Write mode: Write 0x000F to R84 (0054h)
Step 11	HPOUT1L_OUTP = 1 HPOUT1L_RMV_SHORT = 1 HPOUT1R_OUTP = 1 HPOUT1R_RMV_SHORT = 1

**Table 54 Headphone Output Enable Sequence**

SEQUENCE	HEADPHONE DISABLE
Step 1	HPOUT1L_RMV_SHORT = 0 HPOUT1L_DLY = 0 HPOUT1L_OUTP = 0 HPOUT1R_RMV_SHORT = 0 HPOUT1R_DLY = 0 HPOUT1R_OUTP = 0
Step 2	HPOUT1L_ENA = 0 HPOUT1R_ENA = 0

**Table 55 Headphone Output Disable Sequence**

The register bits relating to pop suppression control are defined in Table 56.

REGISTER ADDRESS	BIT	LABEL	DEFAULT	DESCRIPTION
R1 (0001h) Power Management (1)	9	HPOUT1L_ENA	0	Enables HPOUT1L input stage 0 = Disabled 1 = Enabled For normal operation, this bit should be set as the first step of the HPOUT1L Enable sequence.
	8	HPOUT1R_ENA	0	Enables HPOUT1R input stage 0 = Disabled 1 = Enabled For normal operation, this bit should be set as the first step of the HPOUT1R Enable sequence.
R96 (0060h) Analogue HP (1)	7	HPOUT1L_RMV_SHORT	0	Removes HPOUT1L short 0 = HPOUT1L short enabled 1 = HPOUT1L short removed For normal operation, this bit should be set as the final step of the HPOUT1L Enable sequence.
	6	HPOUT1L_OUTP	0	Enables HPOUT1L output stage 0 = Disabled 1 = Enabled For normal operation, this bit should be set to 1 after the DC offset cancellation has been scheduled.
	5	HPOUT1L_DLY	0	Enables HPOUT1L intermediate stage 0 = Disabled 1 = Enabled For normal operation, this bit should be set to 1 after the output signal path has been configured, and before DC offset cancellation is scheduled. This bit should be set with at least 20us delay after HPOUT1L_ENA.
	3	HPOUT1R_RMV_SHORT	0	Removes HPOUT1R short 0 = HPOUT1R short enabled 1 = HPOUT1R short removed For normal operation, this bit should be set as the final step of the HPOUT1R Enable sequence.
	2	HPOUT1R_OUTP	0	Enables HPOUT1R output stage 0 = Disabled 1 = Enabled For normal operation, this bit should be set to 1 after the DC offset cancellation has been scheduled.
	1	HPOUT1R_DLY	0	Enables HPOUT1R intermediate stage 0 = Disabled 1 = Enabled For normal operation, this bit should be set to 1 after the output signal path has been configured, and before DC offset cancellation is scheduled. This bit should be set with at least 20us delay after HPOUT1R_ENA.

Table 56 Headphone Output Signal Paths Control

**OUTPUT MIXER CONTROL**

The Output Mixer path select and volume controls are described in Table 57 for the Left Channel (MIXOUTL) and Table 58 for the Right Channel (MIXOUTR). The gain of each of input path may be controlled independently in the range 0dB to -9dB.

Note that the DAC input levels may also be controlled by the DAC Output Paths digital volume controls(see "Digital Mixing") and also (when applicable) by the Audio Interface Input Paths digital volume controls(see "Digital Volume and Filter Control").

When using the IN2LP, IN2LN, IN2RP or IN2RN signal paths to the output mixers, the buffered VMID reference must be enabled, using the VMID\_BUF\_ENA register, as described in "Reference Voltages and Master Bias".

REGISTER ADDRESS	BIT	LABEL	DEFAULT	DESCRIPTION
R45 (002Dh) Output Mixer (1)	5	IN2RN_TO_MIXOUT L	0	IN2RN to MIXOUTL Mute 0 = Mute 1 = Un-mute Note that VMID_BUF_ENA must be set when using the IN2RN input to MIXOUTL.
R49 (0031h) Output Mixer (5)	8:6	IN2RN_MIXOUTL_V OL[2:0]	000	IN2RN to MIXOUTL Volume 0dB to -9dB in 3dB steps X00 = 0dB X01 = -3dB X10 = -6dB X11 = -9dB
R45 (002Dh) Output Mixer (1)	4	IN2LN_TO_MIXOUTL	0	IN2LN to MIXOUTL Mute 0 = Mute 1 = Un-mute Note that VMID_BUF_ENA must be set when using the IN2LN input to MIXOUTL.
R47 (002Fh) Output Mixer (3)	8:6	IN2LN_MIXOUTL_VO L[2:0]	000	IN2LN to MIXOUTL Volume 0dB to -9dB in 3dB steps X00 = 0dB X01 = -3dB X10 = -6dB X11 = -9dB
R45 (002Dh) Output Mixer (1)	2	IN1L_TO_MIXOUTL	0	IN1LPGA Output to MIXOUTL Mute 0 = Mute 1 = Un-mute
R47 (002Fh) Output Mixer (3)	2:0	IN1L_MIXOUTL_VOL [2:0]	000	IN1LPGA Output to MIXOUTL Volume 0dB to -9dB in 3dB steps X00 = 0dB X01 = -3dB X10 = -6dB X11 = -9dB
R45 (002Dh) Output Mixer (1)	3	IN1R_TO_MIXOUTL	0	IN1RPGA Output to MIXOUTL Mute 0 = Mute 1 = Un-mute



REGISTER ADDRESS	BIT	LABEL	DEFAULT	DESCRIPTION
R47 (002Fh) Output Mixer (3)	5:3	IN1R_MIXOUTL_VOL [2:0]	000	IN1RPGA Output to MIXOUTL Volume 0dB to -9dB in 3dB steps X00 = 0dB X01 = -3dB X10 = -6dB X11 = -9dB
R45 (002Dh) Output Mixer (1)	1	IN2LP_TO_MIXOUTL	0	IN2LP to MIXOUTL Mute 0 = Mute 1 = Un-mute Note that VMID_BUF_ENA must be set when using the IN2LP input to MIXOUTL.
R47 (002Fh) Output Mixer (3)	11:9	IN2LP_MIXOUTL_VO L[2:0]	000	IN2LP to MIXOUTL Volume 0dB to -9dB in 3dB steps X00 = 0dB X01 = -3dB X10 = -6dB X11 = -9dB
R45 (002Dh) Output Mixer (1)	7	MIXINR_TO_MIXOU TL	0	MIXINR Output (Right ADC bypass) to MIXOUTL Mute 0 = Mute 1 = Un-mute
R49 (0031h) Output Mixer (5)	5:3	MIXINR_MIXOUTL_V OL[2:0]	000	MIXINR Output (Right ADC bypass) to MIXOUTL Volume 0dB to -9dB in 3dB steps X00 = 0dB X01 = -3dB X10 = -6dB X11 = -9dB
R45 (002Dh) Output Mixer (1)	6	MIXINL_TO_MIXOUT L	0	MIXINL Output (Left ADC bypass) to MIXOUTL Mute 0 = Mute 1 = Un-mute
R49 (0031h) Output Mixer (5)	2:0	MIXINL_MIXOUTL_V OL[2:0]	000	MIXINL Output (Left ADC bypass) to MIXOUTL Volume 0dB to -9dB in 3dB steps X00 = 0dB X01 = -3dB X10 = -6dB X11 = -9dB
R45 (002Dh) Output Mixer (1)	0	DAC1L_TO_MIXOUT L	0	Left DAC to MIXOUTL Mute 0 = Mute 1 = Un-mute
R49 (0031h) Output Mixer (5)	11:9	DAC1L_MIXOUTL_V OL[2:0]	000	Left DAC to MIXOUTL Volume 0dB to -9dB in 3dB steps X00 = 0dB X01 = -3dB X10 = -6dB X11 = -9dB

Table 57 Left Output Mixer (MIXOUTL) Control

REGISTER ADDRESS	BIT	LABEL	DEFAULT	DESCRIPTION
R46 (002Eh) Output Mixer (2)	5	IN2LN_TO_MIXOUT R	0	IN2LN to MIXOUTR Mute 0 = Mute 1 = Un-mute Note that VMID_BUF_ENA must be set when using the IN2LN input to MIXOUTR.
R50 (0032h) Output Mixer (6)	8:6	IN2LN_MIXOUTR_V OL[2:0]	000	IN2LN to MIXOUTR Volume 0dB to -9dB in 3dB steps X00 = 0dB X01 = -3dB X10 = -6dB X11 = -9dB
R46 (002Eh) Output Mixer (2)	4	IN2RN_TO_MIXOUT R	0	IN2RN to MIXOUTR Mute 0 = Mute 1 = Un-mute Note that VMID_BUF_ENA must be set when using the IN2RN input to MIXOUTR.
R48 (0030h) Output Mixer (4)	8:6	IN2RN_MIXOUTR_V OL[2:0]	000	IN2RN to MIXOUTR Volume 0dB to -9dB in 3dB steps X00 = 0dB X01 = -3dB X10 = -6dB X11 = -9dB
R46 (002Eh) Output Mixer (2)	3	IN1L_TO_MIXOUTR	0	IN1L PGA Output to MIXOUTR Mute 0 = Mute 1 = Un-mute
R48 (0030h) Output Mixer (4)	5:3	IN1L_MIXOUTR_VO L[2:0]	000	IN1L PGA Output to MIXOUTR Volume 0dB to -9dB in 3dB steps X00 = 0dB X01 = -3dB X10 = -6dB X11 = -9dB
R46 (002Eh) Output Mixer (2)	2	IN1R_TO_MIXOUTR	0	IN1R PGA Output to MIXOUTR Mute 0 = Mute 1 = Un-mute
R48 (0030h) Output Mixer (4)	2:0	IN1R_MIXOUTR_VO L[2:0]	000	IN1R PGA Output to MIXOUTR Volume 0dB to -9dB in 3dB steps X00 = 0dB X01 = -3dB X10 = -6dB X11 = -9dB
R46 (002Eh) Output Mixer (2)	1	IN2RP_TO_MIXOUT R	0	IN2RP to MIXOUTR Mute 0 = Mute 1 = Un-mute Note that VMID_BUF_ENA must be set when using the IN2RP input to MIXOUTR.

REGISTER ADDRESS	BIT	LABEL	DEFAULT	DESCRIPTION
R48 (0030h) Output Mixer (4)	11:9	IN2RP_MIXOUTR_V OL[2:0]	000	IN2RP to MIXOUTR Volume 0dB to -9dB in 3dB steps X00 = 0dB X01 = -3dB X10 = -6dB X11 = -9dB
R46 (002Eh) Output Mixer (2)	7	MIXINL_TO_MIXOU TR	0	MIXINL Output (LeftADC bypass) to MIXOUTR Mute 0 = Mute 1 = Un-mute
R50 (0032h) Output Mixer (6)	5:3	MIXINL_MIXOUTR_ VOL[2:0]	000	MIXINL Output (LeftADC bypass) to MIXOUTR Volume 0dB to -9dB in 3dB steps X00 = 0dB X01 = -3dB X10 = -6dB X11 = -9dB
R46 (002Eh) Output Mixer (2)	6	MIXINR_TO_MIXOU TR	0	MIXINR Output (RightADC bypass) to MIXOUTR Mute 0 = Mute 1 = Un-mute
R50 (0032h) Output Mixer (6)	2:0	MIXINR_MIXOUTR_ VOL[2:0]	000	MIXINR Output (RightADC bypass) to MIXOUTR Volume 0dB to -9dB in 3dB steps X00 = 0dB X01 = -3dB X10 = -6dB X11 = -9dB
R46 (002Eh) Output Mixer (2)	0	DAC1R_TO_MIXOU TR	0	Right DAC to MIXOUTR Mute 0 = Mute 1 = Un-mute
R50 (0032h) Output Mixer (6)	11:9	DAC1R_MIXOUTR_ VOL[2:0]	000	Right DAC to MIXOUTR Volume 0dB to -9dB in 3dB steps X00 = 0dB X01 = -3dB X10 = -6dB X11 = -9dB

Table 58 Right Output Mixer (MIXOUTR) Control

**SPEAKER MIXER CONTROL**

The Speaker Mixer path select and volume controls are described in Table 59 for the Left Channel (SPKMIXL) and Table 60 for the Right Channel (SPKMIXR).

Care should be taken when enabling more than one path to a speaker mixer in order to avoid clipping. The gain of each input path is adjustable using a selectable -6dB control in each path to facilitate this. Each Speaker Mixer output can also be muted using the SPKMIXL\_VOL or SPKMIXR\_VOL register.

Note that the DAC input levels may also be controlled by the DAC Output Paths digital volume controls (see "Digital Mixing") and also (when applicable) by the Audio Interface Input Paths digital volume controls (see "Digital Volume and Filter Control").

When using the IN1LP or IN1RP signal paths to the speaker mixers, the buffered VMID reference must be enabled, using the VMID\_BUF\_ENA register, as described in "Reference Voltages and Master Bias".

REGISTER ADDRESS	BIT	LABEL	DEFAULT	DESCRIPTION
R54 (0034h) Speaker Mixer	7	MIXINL_TO_SPKMIXL	0	MIXINL (Left ADC bypass) to SPKMIXL Mute 0 = Mute 1 = Un-mute
	5	IN1LP_TO_SPKMIXL	0	IN1LP to SPKMIXL Mute 0 = Mute 1 = Un-mute Note that VMID_BUF_ENA must be set when using the IN1LP input to SPKMIXL.
	3	MIXOUTL_TO_SPKMIXL	0	Left Mixer Output to SPKMIXL Mute 0 = Mute 1 = Un-mute
	1	DAC1L_TO_SPKMIXL	0	Left DAC to SPKMIXL Mute 0 = Mute 1 = Un-mute
R34 (0022h) SPKMIXL Attenuation	5	MIXINL_SPKMIXL_VOL	0	MIXINL (Left ADC bypass) to SPKMIXL Fine Volume Control 0 = 0dB 1 = -6dB
	4	IN1LP_SPKMIXL_VOL	0	IN1LP to SPKMIXL Fine Volume Control 0 = 0dB 1 = -6dB
	3	MIXOUTL_SPKMIXL_VOL	0	Left Mixer Output to SPKMIXL Fine Volume Control 0 = 0dB 1 = -6dB
	2	DAC1L_SPKMIXL_VOL	0	Left DAC to SPKMIXL Fine Volume Control 0 = 0dB 1 = -6dB
	1:0	SPKMIXL_VOL [1:0]	11	Left Speaker Mixer Volume Control 00 = 0dB 01 = Reserved 10 = Reserved 11 = Mute

**Table 59 Left Speaker Mixer (SPKMIXL) Control**

REGISTER ADDRESS	BIT	LABEL	DEFAULT	DESCRIPTION
R54 (0034h) Speaker Mixer	6	MIXINR_TO_SPKMIXR	0	MIXINR (Right ADC bypass) to SPKMIXR Mute 0 = Mute 1 = Un-mute
	4	IN1RP_TO_SPKMIXR	0	IN1RP to SPKMIXR Mute 0 = Mute 1 = Un-mute Note that VMID_BUF_ENA must be set when using the IN1RP input to SPKMIXR.
	2	MIXOUTR_TO_SPKMIXR	0	Right Mixer Output to SPKMIXR Mute 0 = Mute 1 = Un-mute
	0	DAC1R_TO_SPKMIXR	0	Right DAC to SPKMIXR Mute 0 = Mute 1 = Un-mute
R35 (0023h) SPKMIXR Attenuation	5	MIXINR_SPKMIXR_VOL	0	MIXINR (Right ADC bypass) to SPKMIXR Fine Volume Control 0 = 0dB 1 = -6dB
	4	IN1RP_SPKMIXR_VOL	0	IN1RP to SPKMIXR Fine Volume Control 0 = 0dB 1 = -6dB
	3	MIXOUTR_SPKMIXR_VOL	0	Right Mixer Output to SPKMIXR Fine Volume Control 0 = 0dB 1 = -6dB
	2	DAC1R_SPKMIXR_VOL	0	Right DAC to SPKMIXR Fine Volume Control 0 = 0dB 1 = -6dB
	1:0	SPKMIXR_VOL [1:0]	11	Right Speaker Mixer Volume Control 00 = 0dB 01 = Reserved 10 = Reserved 11 = Mute

Table 60 Right Speaker Mixer (SPKMIXR) Control

### OUTPUT SIGNAL PATH VOLUME CONTROL

There are six output PGAs - MIXOUTLVOL, MIXOUTRVOL, HPOUT1LVOL, HPOUT1RVOL, SPKLVOL and SPKRVOL. Each can be independently controlled, with MIXOUTLVOL and MIXOUTRVOL providing volume control to both the earpiece and line drivers, HPOUT1LVOL and HPOUT1RVOL to the headphone driver, and SPKLVOL and SPKRVOL to the speaker drivers.

The volume control of each of these output PGAs can be adjusted over a wide range of values. To minimise pop noise, it is recommended that only the MIXOUTLVOL, MIXOUTRVOL, HPOUT1LVOL, HPOUT1RVOL, SPKLVOL and SPKRVOL are modified while the output signal path is active. Other gain controls are provided in the signal paths to provide scaling of signals from different sources, and to prevent clipping when multiple signals are mixed. However, to prevent pop noise, it is recommended that those other gain controls should not be modified while the signal path is active.

To prevent "zipper noise", a zero-cross function is provided on the output PGAs. When this feature is enabled, volume updates will not take place until a zero-crossing is detected. In the case of a long period without zero-crossings, a timeout function is provided. When the zero-cross function is enabled, the volume will update after the timeout period if no earlier zero-cross has occurred. The timeout clock is enabled using TOCLK\_ENA; the timeout period is set by TOCLK\_DIV. See "Clocking and Sample Rates" for more information on these fields.

The mixer output PGA controls are shown in Table 61. The MIXOUT\_VU bits control the loading of the output mixer PGA volume data. When MIXOUT\_VU is set to 0, the volume control data will be loaded into the respective control register, but will not actually change the gain setting. The output mixer PGA volume settings are both updated when a 1 is written to either MIXOUT\_VU bit. This makes it possible to update the gain of both output paths simultaneously.

REGISTER ADDRESS	BIT	LABEL	DEFAULT	DESCRIPTION
R32 (0020h) Left OPGA Volume	8	MIXOUT_VU	N/A	Mixer Output PGA Volume Update Writing a 1 to this bit will update MIXOUTLVOL and MIXOUTRVOL volumes simultaneously.
	7	MIXOUTL_ZC	0	MIXOUTLVOL (Left Mixer Output PGA) Zero Cross Enable 0 = Zero cross disabled 1 = Zero cross enabled
	6	MIXOUTL_MUTE_N	1	MIXOUTLVOL (Left Mixer Output PGA) Mute 0 = Mute 1 = Un-mute
	5:0	MIXOUTL_VOL[5:0]	39h (0dB)	MIXOUTLVOL (Left Mixer Output PGA) Volume -57dB to +6dB in 1dB steps 00_0000 = -57dB 00_0001 = -56dB ... (1dB steps) 11_1111 = +6dB (See Table 64 for output PGA volume control range)
R33 (0021h) Right OPGA Volume	8	MIXOUT_VU	N/A	Mixer Output PGA Volume Update Writing a 1 to this bit will update MIXOUTLVOL and MIXOUTRVOL volumes simultaneously.
	7	MIXOUTR_ZC	0	MIXOUTRVOL (Right Mixer Output PGA) Zero Cross Enable 0 = Zero cross disabled 1 = Zero cross enabled
	6	MIXOUTR_MUTE_N	1	MIXOUTRVOL (Right Mixer Output PGA) Mute 0 = Mute 1 = Un-mute

REGISTER ADDRESS	BIT	LABEL	DEFAULT	DESCRIPTION
	5:0	MIXOUTR_VOL[5:0]	39h (0dB)	MIXOUTRVOL (Right Mixer Output PGA) Volume -57dB to +6dB in 1dB steps 00_0000 = -57dB 00_0001 = -56dB ... (1dB steps) 11_1111 = +6dB (See Table 64 for output PGA volume control range)

**Table 61 Mixer Output PGA (MIXOUTLVOL, MIXOUTRVOL) Control**

The headphone output PGA controls are shown in Table 62. The HPOUT1\_VU bits control the loading of the headphone PGA volume data. When HPOUT1\_VU is set to 0, the volume control data will be loaded into the respective control register, but will not actually change the gain setting. The headphone PGA volume settings are both updated when a 1 is written to either HPOUT1\_VU bit. This makes it possible to update the gain of both output paths simultaneously.

The HPOUT1\_ATTEN register controls a -3dB attenuation function in the HPOUT1L and HPOUT1R signal paths. (Note that this single register applies to the Left and Right output paths.) The output path Signal to Noise Ratio (SNR) may be improved when the HPOUT1\_ATTEN bit is set, but the maximum signal level is reduced by 3dB.

Note that, when the HPOUT1\_ATTEN register is updated in Register Control mode (CP\_DYN\_PWR=0), the HPOUT1\_ATTEN function is not fully implemented until a '1' has been written to HPOUT1\_VU. See "Charge Pump" for details of the CP\_DYN\_PWR register bit.

The DAC1L\_TO\_HPOUT1L and DAC1R\_TO\_HPOUT1R register bits allow the DACL and DACR outputs to be selected as the single input to the HPOUT1L and HPOUT1R headphone output PGAs respectively. When these bits are asserted, the respective output mixer settings are ignored, and only the DAC path(s) are enabled. Note that these register controls are provided for software compatibility with WM8994; it is not recommended to use these register bits.

REGISTER ADDRESS	BIT	LABEL	DEFAULT	DESCRIPTION
R28 (001Ch) Left Output Volume	8	HPOUT1_VU	N/A	Headphone Output PGA Volume Update Writing a 1 to this bit will update HPOUT1LVOL and HPOUT1RVOL volumes simultaneously.
	7	HPOUT1L_ZC	0	HPOUT1LVOL (Left Headphone Output PGA) Zero Cross Enable 0 = Zero cross disabled 1 = Zero cross enabled
	6	HPOUT1L_MUTE_N	1	HPOUT1LVOL (Left Headphone Output PGA) Mute 0 = Mute 1 = Un-mute
	5:0	HPOUT1L_VOL[5:0]	2Dh (-12dB)	HPOUT1LVOL (Left Headphone Output PGA) Volume -57dB to +6dB in 1dB steps 00_0000 = -57dB 00_0001 = -56dB ... (1dB steps) 11_1111 = +6dB (See Table 64 for output PGA volume control range)

REGISTER ADDRESS	BIT	LABEL	DEFAULT	DESCRIPTION
R45 (002Dh) Output Mixer (1)	8	DAC1L_TO_HPOUT1L	0	HPOUT1LVOL (Left Headphone Output PGA) Input Select 0 = MIXOUTL 1 = DACL
R29 (001Dh) Right Output Volume	8	HPOUT1_VU	N/A	Headphone Output PGA Volume Update Writing a 1 to this bit will update HPOUT1LVOL and HPOUT1RVOL volumes simultaneously.
	7	HPOUT1R_ZC	0	HPOUT1RVOL (Right Headphone Output PGA) Zero Cross Enable 0 = Zero cross disabled 1 = Zero cross enabled
	6	HPOUT1R_MUTE_N	1	HPOUT1RVOL (Right Headphone Output PGA) Mute 0 = Mute 1 = Un-mute
	5:0	HPOUT1R_VOL[5:0]	2Dh (-12dB)	HPOUT1RVOL (Right Headphone Output PGA) Volume -57dB to +6dB in 1dB steps 00_0000 = -57dB 00_0001 = -56dB ... (1dB steps) 11_1111 = +6dB (See Table 64 for output PGA volume control range)
R46 (002Eh) Output Mixer (2)	8	DAC1R_TO_HPOUT1R	0	HPOUT1RVOL (Right Headphone Output PGA) Input Select 0 = MIXOUTR 1 = DACR
R96 (0060h) Analogue HP (1)	8	HPOUT1_ATTN	0	HPOUT1L and HPOUT1R Attenuation 0 = 0dB 1 = -3dB  Note that, when CP_DYN_PWR=0, then any update to HPOUT1_ATTN is not fully implemented until a '1' is written to HPOUT1_VU.

Table 62 Headphone Output PGA (HPOUT1LVOL, HPOUT1RVOL) Control



The speakeroutput PGA controls are shown in Table 63. The SPKOUT\_VU bits control the loading of the speaker PGA volume data. When SPKOUT\_VU is set to 0, the volume control data will be loaded into the respective control register, but will not actually change the gain setting. The speaker PGA volume settings are both updated when a 1 is written to either SPKOUT\_VU bit. This makes it possible to update the gain of both output paths simultaneously.

REGISTER ADDRESS	BIT	LABEL	DEFAULT	DESCRIPTION
R38 (0026h) Speaker Volume Left	8	SPKOUT_VU	N/A	SpeakerOutput PGA Volume Update Writing a 1 to this bit will update SPKLVOL and SPKRVOL volumes simultaneously.
	7	SPKOUTL_ZC	0	SPKLVOL (Left Speaker Output PGA) Zero Cross Enable 0 = Zero cross disabled 1 = Zero cross enabled
	6	SPKOUTL_MUTE_N	1	SPKLVOL (Left Speaker Output PGA) Mute 0 = Mute 1 = Un-mute
	5:0	SPKOUTL_VOL[5:0]	39h (0dB)	SPKLVOL (Left Speaker Output PGA) Volume -57dB to +6dB in 1dB steps 00_0000 = -57dB 00_0001 = -56dB ... (1dB steps) 11_1111 = +6dB (See Table 64 for output PGA volume control range)
R39 (0027h) Speaker Volume Right	8	SPKOUT_VU	N/A	Speaker PGA Volume Update Writing a 1 to this bit will update SPKLVOL and SPKRVOL volumes simultaneously.
	7	SPKOUTR_ZC	0	SPKRVOL (Right Speaker Output PGA) Zero Cross Enable 0 = Zero cross disabled 1 = Zero cross enabled
	6	SPKOUTR_MUTE_N	1	SPKRVOL (Right Speaker Output PGA) Mute 0 = Mute 1 = Un-mute
	5:0	SPKOUTR_VOL[5:0]	39h (0dB)	SPKRVOL (Right Speaker Output PGA) Volume -57dB to +6dB in 1dB steps 00_0000 = -57dB 00_0001 = -56dB ... (1dB steps) 11_1111 = +6dB (See Table 64 for output PGA volume control range)

Table 63 Speaker Output PGA (SPKLVOL, SPKRVOL) Control

PGA GAIN SETTING	VOLUME (dB)	PGA GAIN SETTING	VOLUME (dB)
00h	-57	20h	-25
01h	-56	21h	-24
02h	-55	22h	-23
03h	-54	23h	-22
04h	-53	24h	-21
05h	-52	25h	-20
06h	-51	26h	-19
07h	-50	27h	-18
08h	-49	28h	-17
09h	-48	29h	-16
0Ah	-47	2Ah	-15
0Bh	-46	2Bh	-14
0Ch	-45	2Ch	-13
0Dh	-44	2Dh	-12
0Eh	-43	2Eh	-11
0Fh	-42	2Fh	-10
10h	-41	30h	-9
11h	-40	31h	-8
12h	-39	32h	-7
13h	-38	33h	-6
14h	-37	34h	-5
15h	-36	35h	-4
16h	-35	36h	-3
17h	-34	37h	-2
18h	-33	38h	-1
19h	-32	39h	0
1Ah	-31	3Ah	+1
1Bh	-30	3Bh	+2
1Ch	-29	3Ch	+3
1Dh	-28	3Dh	+4
1Eh	-27	3Eh	+5
1Fh	-26	3Fh	+6

Table 64 Output PGA Volume Range

### SPEAKER BOOST MIXER

Each speaker driver has its own boost mixer which performs a dual role. It allows the output from the left speaker mixer (via SPKLVOL) or the right speaker mixer (via SPKRVOL) to be routed to either speaker driver. The speaker boost mixers are controlled using the registers defined in Table 65 below.

The second function of the speaker boost mixers is that they provide an additional AC gain (boost) function to shift signal levels between the AVDD1 and SPKVDD voltage domains for maximum output power. The AC gain (boost) function is described in the “Analogue Outputs” section.

REGISTER ADDRESS	BIT	LABEL	DEFAULT	DESCRIPTION
R36 (0024h) SPKOUT Mixers	4	SPKMIXL_TO_SPK OUTL	1	SPKMIXL Left Speaker Mixer to Left Speaker Mute 0 = Mute 1 = Un-mute
	3	SPKMIXR_TO_SPK OUTL	0	SPKMIXR Right Speaker Mixer to Left Speaker Mute 0 = Mute 1 = Un-mute
	1	SPKMIXL_TO_SPK OUTR	0	SPKMIXL Left Speaker Mixer to Right Speaker Mute 0 = Mute 1 = Un-mute
	0	SPKMIXR_TO_SPK OUTR	1	SPKMIXR Right Speaker Mixer to Right Speaker Mute 0 = Mute 1 = Un-mute

**Table 65 Speaker Boost Mixer (SPKOUTLBOOST, SPKOUTRBOOST) Control**

### EARPIECE DRIVER MIXER

The earpiece driver has a dedicated mixer, HPOUT2MIX, which is controlled using the registers defined in Table 66. The earpiece driver is configurable to select output from the left output mixer (via MIXOUTLVOL) or the right output mixer (via MIXOUTRVOL).

Care should be taken to avoid clipping when enabling more than one path to the earpiece driver. The HPOUT2VOL volume control can be used to avoid clipping when more than one full scale signal is input to the mixer.

REGISTER ADDRESS	BIT	LABEL	DEFAULT	DESCRIPTION
R31 (001Fh) HPOUT2 Volume	5	HPOUT2_MUTE	1	HPOUT2 (Earpiece Driver) Mute 0 = Un-mute 1 = Mute
	4	HPOUT2_VOL	0	HPOUT2 (Earpiece Driver) Volume 0 = 0dB 1 = -6dB
R51 (0033h) HPOUT2 Mixer	4	MIXOUTLVOL_TO_ HPOUT2	0	MIXOUTLVOL (Left Output Mixer PGA) to Earpiece Driver 0 = Mute 1 = Un-mute
	3	MIXOUTRVOL_TO_ HPOUT2	0	MIXOUTRVOL (Right Output Mixer PGA) to Earpiece Driver 0 = Mute 1 = Un-mute

Table 66 Earpiece Driver Mixer (HPOUT2MIX) Control

### LINE OUTPUT MIXERS

The WM1811A provides two pairs of line outputs, both with highly configurable output mixers. The outputs LINEOUT1N and LINEOUT1P can be configured as two single-ended outputs or as a differential output. In the same manner, LINEOUT2N and LINEOUT2P can be configured either as two single-ended outputs or as a differential output. The respective line output mixers can be configured in single-ended mode or differential mode; each mode supports multiple signal path configurations.

LINEOUT1 single-ended mode is selected by setting LINEOUT1\_MODE = 1. In single-ended mode, any of three possible signal paths may be enabled:

- MIXOUTL (left output mixer) to LINEOUT1P
- MIXOUTR (right output mixer) to LINEOUT1N
- MIXOUTL (left output mixer) to LINEOUT1N

LINEOUT1 differential mode is selected by setting LINEOUT1\_MODE = 0. In differential mode, any of three possible signal paths may be enabled:

- MIXOUTL (left output mixer) to LINEOUT1N and LINEOUT1P
- IN1L (input PGA) to LINEOUT1N and LINEOUT1P
- IN1R (input PGA) to LINEOUT1N and LINEOUT1P

The LINEOUT1 output mixers are controlled as described in Table 67. Care should be taken to avoid clipping when enabling more than one path to the line output mixers. The LINEOUT1\_VOL control can be used to provide -6dB attenuation when more than one full scale signal is applied.

When using the LINEOUT1 mixers in single-ended mode, a buffered VMID must be enabled. This is achieved by setting LINEOUT\_VMID\_BUF\_ENA, as described in the "Analogue Outputs" section.

REGISTER ADDRESS	BIT	LABEL	DEFAULT	DESCRIPTION
R30 (001Eh) Line Outputs Volume	6	LINEOUT1N_MUTE	1	LINEOUT1N Line Output Mute 0 = Un-mute 1 = Mute
	5	LINEOUT1P_MUTE	1	LINEOUT1P Line Output Mute 0 = Un-mute 1 = Mute
	4	LINEOUT1_VOL	0	LINEOUT1 Line Output Volume 0 = 0dB 1 = -6dB Applies to both LINEOUT1N and LINEOUT1P
R52 (0034h) Line Mixer (1)	6	MIXOUTL_TO_LIN EOUT1N	0	MIXOUTL to Single-Ended Line Output on LINEOUT1N 0 = Mute 1 = Un-mute (LINEOUT1_MODE = 1)
	5	MIXOUTR_TO_LIN EOUT1N	0	MIXOUTR to Single-Ended Line Output on LINEOUT1N 0 = Mute 1 = Un-mute (LINEOUT1_MODE = 1)
	4	LINEOUT1_MODE	0	LINEOUT1 Mode Select 0 = Differential 1 = Single-Ended
	2	IN1R_TO_LINEOUT 1P	0	IN1R Input PGA to Differential Line Output on LINEOUT1 0 = Mute 1 = Un-mute (LINEOUT1_MODE = 0)
	1	IN1L_TO_LINEOUT 1P	0	IN1L Input PGA to Differential Line Output on LINEOUT1 0 = Mute 1 = Un-mute (LINEOUT1_MODE = 0)
	0	MIXOUTL_TO_LIN EOUT1P	0	Differential Mode (LINEOUT1_MODE = 0): MIXOUTL to Differential Output on LINEOUT1 0 = Mute 1 = Un-mute  Single Ended Mode (LINEOUT1_MODE = 1): MIXOUTL to Single-Ended Line Output on LINEOUT1P 0 = Mute 1 = Un-mute

Table 67 LINEOUT1N and LINEOUT1P Control

LINEOUT2 single-ended mode is selected by setting LINEOUT2\_MODE = 1. In single-ended mode, any of three possible signal paths may be enabled:

- MIXOUTR (right output mixer) to LINEOUT2P
- MIXOUTL (left output mixer) to LINEOUT2N
- MIXOUTR (right output mixer) to LINEOUT2N

LINEOUT2 differential mode is selected by setting LINEOUT2\_MODE = 0. In differential mode, any of three possible signal paths may be enabled:

- MIXOUTR (right output mixer) to LINEOUT2N and LINEOUT2P
- IN1L (input PGA) to LINEOUT2P and LINEOUT2N
- IN1R (input PGA) to LINEOUT2N and LINEOUT2P

The LINEOUT2 output mixers are controlled as described in Table 68. Care should be taken to avoid clipping when enabling more than one path to the line output mixers. The LINEOUT2\_VOL control can be used to provide -6dB attenuation when more than one full scale signal is applied.

When using the LINEOUT2 mixers in single-ended mode, a buffered VMID must be enabled. This is achieved by setting LINEOUT\_VMID\_BUF\_ENA, as described in the "Analogue Outputs" section.

REGISTER ADDRESS	BIT	LABEL	DEFAULT	DESCRIPTION
R30 (001Eh) Line Outputs Volume	2	LINEOUT2N_MUTE	1	LINEOUT2N Line Output Mute 0 = Un-mute 1 = Mute
	1	LINEOUT2P_MUTE	1	LINEOUT2P Line Output Mute 0 = Un-mute 1 = Mute
	0	LINEOUT2_VOL	0	LINEOUT2 Line Output Volume 0 = 0dB 1 = -6dB Applies to both LINEOUT2N and LINEOUT2P
R53 (0035h) Line Mixer (2)	6	MIXOUTR_TO_LINE OUT2N	0	MIXOUTR to Single-Ended Line Output on LINEOUT2N 0 = Mute 1 = Un-mute (LINEOUT2_MODE = 1)
	5	MIXOUTL_TO_LINE OUT2N	0	MIXOUTL to Single-Ended Line Output on LINEOUT2N 0 = Mute 1 = Un-mute (LINEOUT2_MODE = 1)
	4	LINEOUT2_MODE	0	LINEOUT2 Mode Select 0 = Differential 1 = Single-Ended
	2	IN1L_TO_LINEOUT 2P	0	IN1L Input PGA to Differential Line Output on LINEOUT2 0 = Mute 1 = Un-mute (LINEOUT2_MODE = 0)
	1	IN1R_TO_LINEOUT 2P	0	IN1R Input PGA to Differential Line Output on LINEOUT2 0 = Mute 1 = Un-mute (LINEOUT2_MODE = 0)
	0	MIXOUTR_TO_LINE OUT2P	0	Differential Mode (LINEOUT2_MODE = 0): MIXOUTR to Differential Output on LINEOUT2 0 = Mute 1 = Un-mute  Single-Ended Mode (LINEOUT2_MODE = 0): MIXOUTR to Single-Ended Line Output on LINEOUT2P 0 = Mute 1 = Un-mute

Table 68 LINEOUT2N and LINEOUT2P Control

## CHARGE PUMP

The WM1811A incorporates a dual-mode Charge Pump which generates the supply rails for the headphone output drivers, HPOUT1L and HPOUT1R.

The Charge Pump has a single supply input, CPVDD, and generates split rails CPVOUTP and CPVOUTN according to the selected mode of operation.

The Charge Pump connections are illustrated in Figure 28 (see “Applications Information” for external component values). An input decoupling capacitor may also be required at CPVDD, depending upon the system configuration.

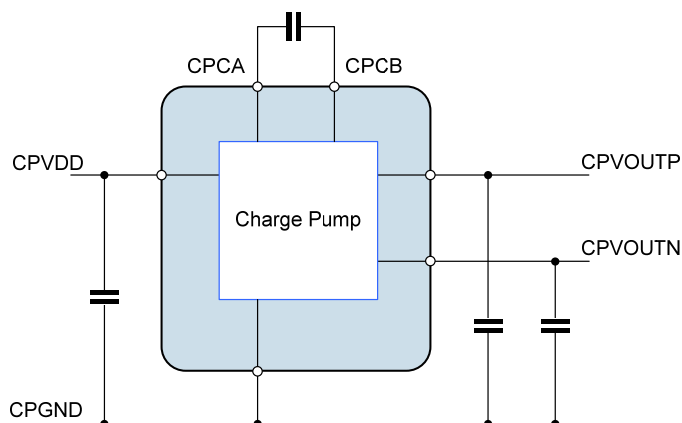

**Figure 28 Charge Pump External Connections**

The Charge Pump is enabled by setting the CP\_ENA bit. When enabled, the charge pump adjusts the output voltages (CPVOUTP and CPVOUTN) as well as the switching frequency in order to optimise the power consumption according to the operating conditions. This can take two forms, which are selected using the CP\_DYN\_PWR register bit.

- Register control (CP\_DYN\_PWR = 0)
- Dynamic control (CP\_DYN\_PWR = 1)

Under Register control, the HPOUT1L\_VOL and HPOUT1R\_VOL register settings are used to control the charge pump mode of operation.

Under Dynamic control, the audio signal level in the digital audio interface is used to control the charge pump mode of operation. The CP\_DYN\_SRC\_SEL register determines which of the digital signal paths is used for this function - this may be the AIF1 DAC path or the AIF2 DAC path. The CP\_DYN\_SRC\_SEL should be set according to the active source for the HPOUT1L and HPOUT1R outputs.

The Dynamic Charge Pump Control mode is the Wolfson ‘Class W’ mode, which allows the power consumption to be optimised in real time, but can only be used if a single AIF source is the only signal source. The Class W mode should not be used if any of the bypass paths are used to feed analogue inputs into the output signal path, or if more than one AIF source is used to feed the headphone output via the Digital Mixers.

The Charge Pump operating mode defaults to Register control; Dynamic control may be selected by setting the CP\_DYN\_PWR register bit, if appropriate.

Note that the charge pump clock is derived from internal clock SYSCLK; either MCLK or the FLL output selectable using the SYSCLK\_SRC bit. Under normal circumstances an external clock signal must be present for the charge pump to function. However, the FLL has a free-running mode that does not require an external clock but will generate an internal clock suitable for running the charge pump. The clock division from SYSCLK is handled transparently by the WM1811A without user intervention, as long as SYSCLK and sample rates are set correctly. Refer to the “Clocking and Sample Rates” section for more detail on the FLL and clocking configuration.



When the Charge Pump is disabled, the output can be left floating or can be actively discharged, depending on the CP\_DISCH control bit.

If the headphone output drivers (HPOUT1L and HPOUT1R) are not used, then the Charge Pump and the associated external components are not required. The Charge Pump and Headphone drivers should not be enabled in this case (CP\_ENA=0, HPOUT1L\_ENA=0, HPOUT1R\_ENA=0).

If the Charge Pump is not used, and the associated external components are omitted, then the CPCA and CPCB pins can be left floating; the CPVOUTP and CPVOUTN pins should be grounded as illustrated in Figure 29.

Note that, when the Charge Pump is disabled, it is still recommended that the CPVDD pin is kept within its recommended operating conditions.

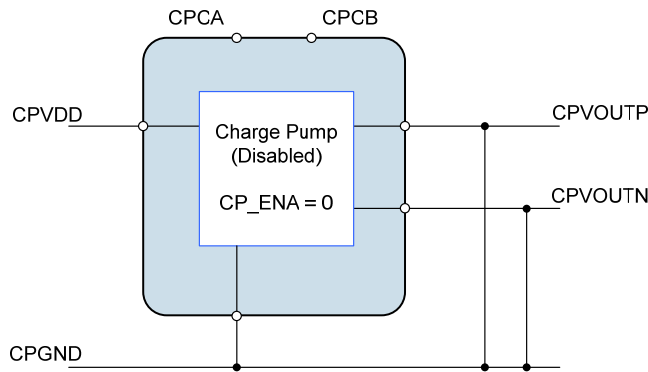

Figure 29 External Configuration when Charge Pump not used

The Charge Pump control fields are described in Table 69.

REGISTER ADDRESS	BIT	LABEL	DEFAULT	DESCRIPTION
R76 (004Ch) Charge Pump (1)	15	CP_ENA	0	Enable charge-pump digits 0 = Disable 1 = Enable
R77 (004Dh) Charge Pump (2)	15	CP_DISCH	1	Charge Pump Discharge Select 0 = Charge Pump outputs floating when disabled 1 = Charge Pump outputs discharged when disabled
R81 (0051h) Class W (1)	9:8	CP_DYN_SRC_SEL	00	Selects the digital audio source for envelope tracking 00 = AIF1, DAC data 01 = Reserved 10 = AIF2, DAC data 11 = Reserved
	0	CP_DYN_PWR	0	Enable dynamic charge pump power control 0 = charge pump controlled by volume register settings (Class G) 1 = charge pump controlled by real-time audio level (Class W)

Table 69 Charge Pump Control

## DC SERVO

The WM1811A provides a DC servo circuit on the headphone outputs HPOUT1L and HPOUT1R in order to remove DC offset from these ground-referenced outputs. When enabled, the DC servo ensures that the DC level of these outputs remains within 1mV of ground. Removal of the DC offset is important because any deviation from GND at the output pin will cause current to flow through the load under quiescent conditions, resulting in increased power consumption. Additionally, the presence of DC offsets can result in audible pops and clicks at power up and power down.

### DC SERVO ENABLE AND START-UP

The DC Servo circuit is enabled on HPOUT1L and HPOUT1R by setting DCS\_ENA\_CHAN\_0 and DCS\_ENA\_CHAN\_1 respectively. When the DC Servo is enabled, the DC offset correction can be commanded in two different ways, as described below.

The DCS\_TIMER\_PERIOD\_01 register must be set to 0000 for correct operation of the DC Servo. This register must be set to 0000 before enabling the DC Servo.

Writing a logic 1 to DCS\_TRIG\_STARTUP\_n initiates a series of DC offset measurements and applies the necessary correction to the associated output; ('n' = 0 for Left channel, 1 for Right channel). On completion, the headphone output will be within 1mV of AGND. This mode is recommended for typical applications. Completion of the DC offset correction triggered in this way is indicated by the DCS\_STARTUP\_COMPLETE field, as described in Table 70. Typically, this operation takes 86ms per channel.

For correct operation of the DC Servo Start-Up mode, it is important that there is no active audio signal present on the signal path while the mode is running. The DC Servo Start-Up mode should be scheduled at the correct position within the Headphone Output Enable sequence, as described in the "Analogue Output Signal Path" section. All other stages of the analogue signal path should be fully enabled prior to commanding the Start-Up mode; the DAC Digital Mute function should be used, where appropriate, to ensure there is no active audio signal present during the DC Servo measurements.

Writing a logic 1 to DCS\_TRIG\_DAC\_WR\_n causes the DC offset correction to be set to the value contained in the DCS\_DAC\_WR\_VAL\_n fields in Register R89. This mode is useful if the required offset correction has already been determined and stored; it is faster than the DCS\_TRIG\_STARTUP\_n mode, but relies on the accuracy of the stored settings. Completion of the DC offset correction triggered in this way is indicated by the DCS\_DAC\_WR\_COMPLETE field, as described in Table 70. Typically, this operation takes 2ms per channel.

For pop-free operation of the DC Servo DAC Write mode, it is important that the mode is scheduled at the correct position within the Headphone Output Enable sequence, as described in the "Analogue Output Signal Path" section.

The current DC offset value for each Headphone output channel can be read from the DCS\_DAC\_WR\_VAL\_n fields. These values may form the basis of settings that are subsequently used by the DC Servo in DAC Write mode. Note that these fields have a different definition for Read and Write, as described in Table 70.

When using either of the DC Servo options above, the status of the DC offset correction process is indicated by the DCS\_CAL\_COMPLETE field; this is the logical OR of the DCS\_STARTUP\_COMPLETE and DCS\_DAC\_WR\_COMPLETE fields.

The DCS\_DAC\_WR\_COMPLETE bits can be used as inputs to the Interrupt control circuit or used to generate an external logic signal on a GPIO pin. See "Interrupts" and "General Purpose Input/Output" for further details.

The DC Servo control fields associated with start-up operation are described in Table 70. It is important to note that, to minimise audible pops/clicks, the Start-Up and DAC Write modes of DC Servo operation should be commanded as part of a control sequence which includes muting and shorting of the headphone outputs.

REGISTER ADDRESS	BIT	LABEL	DEFAULT	DESCRIPTION
R84 (0054h) DC Servo (1)	5	DCS_TRIG_START UP_1	0	Writing 1 to this bit selects Start-Up DC Servo mode for HPOUT1R.  In readback, a value of 1 indicates that the DC Servo Start-Up correction is in progress.
	4	DCS_TRIG_START UP_0	0	Writing 1 to this bit selects Start-Up DC Servo mode for HPOUT1L.  In readback, a value of 1 indicates that the DC Servo Start-Up correction is in progress.
	3	DCS_TRIG_DAC_W R_1	0	Writing 1 to this bit selects DAC Write DC Servo mode for HPOUT1R.  In readback, a value of 1 indicates that the DC Servo DAC Write correction is in progress.
	2	DCS_TRIG_DAC_W R_0	0	Writing 1 to this bit selects DAC Write DC Servo mode for HPOUT1L.  In readback, a value of 1 indicates that the DC Servo DAC Write correction is in progress.
	1	DCS_ENA_CHAN_1	0	DC Servo enable for HPOUT1R 0 = Disabled 1 = Enabled
	0	DCS_ENA_CHAN_0	0	DC Servo enable for HPOUT1L 0 = Disabled 1 = Enabled
	R85 (0055h) DC Servo (2)	3:0	DCS_TIMER_PERIOD_01 [3:0]	1010
R88 (0058h) DC Servo Readback	9:8	DCS_CAL_COMPLETE [1:0]	00	DC Servo Complete status 0 = DAC Write or Start-Up DC Servo mode not completed. 1 = DAC Write or Start-Up DC Servo mode complete. Bit [1] = HPOUT1R Bit [0] = HPOUT1L
	5:4	DCS_DAC_WRITE_COMPLETE [1:0]	00	DC Servo DAC Write status 0 = DAC Write DC Servo mode not completed. 1 = DAC Write DC Servo mode complete. Bit [1] = HPOUT1R Bit [0] = HPOUT1L

REGISTER ADDRESS	BIT	LABEL	DEFAULT	DESCRIPTION
	1:0	DCS_STARTUP_COMPLETE [1:0]	00	DC Servo Start-Up status 0 = Start-Up DC Servo mode not completed. 1 = Start-Up DC Servo mode complete. Bit [1] = HPOUT1R Bit [0] = HPOUT1L
R89 (0059h) DC Servo (4)	15:8	DCS_DAC_WR_VA_L_1 [7:0]	00h	Writing to this field sets the DC Offset value for HPOUT1R in DAC Write DC Servo mode. Reading this field gives the current DC Offset value for HPOUT1R. Two's complement format. LSB is 0.25mV. Range is -32mV to +31.75mV
	7:0	DCS_DAC_WR_VA_L_0 [7:0]	00h	Writing to this field sets the DC Offset value for HPOUT1L in DAC Write DC Servo mode. Reading this field gives the current DC Offset value for HPOUT1L. Two's complement format. LSB is 0.25mV. Range is -32mV to +31.75mV

Table 70 DC Servo Control

### GPIO / INTERRUPT OUTPUTS FROM DC SERVO

When using the DC Servo Start-Up or DAC Write modes, the DCS\_CAL\_COMPLETE register provides readback of the status of the DC offset correction. This can be read from register R88 as described in Table 70.

The DCS\_CAL\_COMPLETE bits can also be used as inputs to the Interrupt control circuit and used to trigger an Interrupt event - see "Interrupts".

The DCS\_CAL\_COMPLETE bits can also be used as inputs to the GPIO function and used to generate external logic signals indicating the DC Servo status. See "General Purpose Input/Output" for details of how to configure a GPIO pin to output the DC Servo status.

## ANALOGUE OUTPUTS

The speaker, headphone, earpiece and line outputs are highly configurable and may be used in many different ways.

### SPEAKER OUTPUT CONFIGURATIONS

The speaker outputs SPKOUTL and SPKOUTR can be driven by either of the speaker mixers, SPKMIXL or SPKMIXR. Fine volume control is available on the speaker mixer paths using the SPKLVOL and SPKRVOL PGAs. A boost function is available on the speaker output paths. For information on the speaker mixing options, refer to the “Analogue Output Signal Path” section.

The speaker outputs SPKOUTL and SPKOUTR operate in a BTL configuration.

The speaker outputs can be configured as a pair of stereo outputs, or as a single mono output. Note that, for applications requiring only a single speaker output, it is possible to improve the THD performance by configuring the speaker outputs in mono mode. See “Typical Performance” for further details.

The mono configuration is selected by applying a logic high input to the SPKMODE pin (D5), as described in Table 71. For Stereo mode this pin should be connected to GND. Note that SPKMODE is referenced to DBVDD1.

An internal pull-up resistor is enabled by default on the SPKMODE pin; this can be configured using the SPKMODE\_PU register bit described in Table 72.

SPEAKER CONFIGURATION	SPKMODE PIN (D5)
Stereo Mode	GND
Mono Mode	DBVDD1

Table 71 SPKMODE Pin Function

In the mono configuration, the P channels, SPKOUTLP and SPKOUTRP should be connected together on the PCB, and similarly with the N channels, SPKOUTLN and SPKOUTRN, as illustrated in Figure 30. In this configuration both left and right speaker drivers should be enabled (SPKOUTL\_ENA=1 and SPKOUTR\_ENA=1), but path selection and volume controls are available on left channel only (SPKMIXL, SPKLVOL and SPKOUTLBOOST).

Note that the minimum speaker load resistance and the maximum power output has a dependency on the SPKMODE output configuration, and also on the Class D/AB mode selection. See “Electrical Characteristics” for further details.

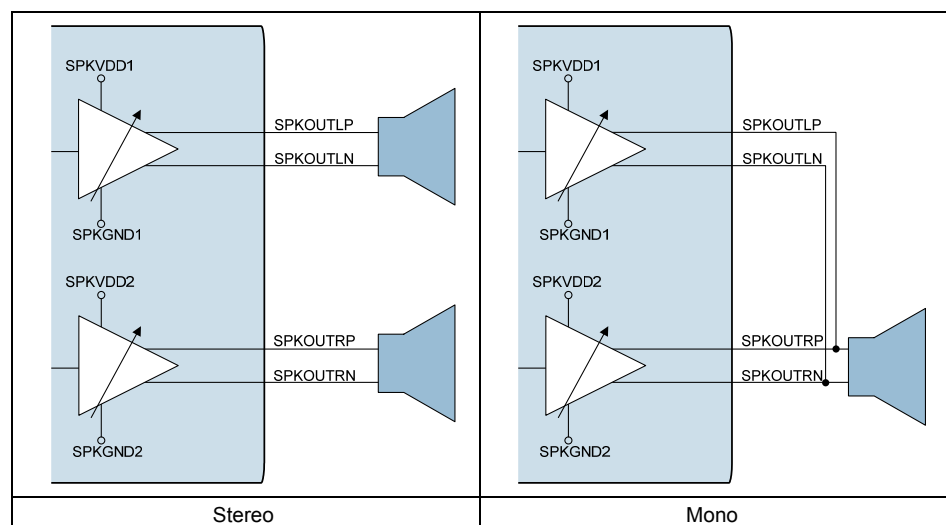

Figure 30 Stereo / Mono Speaker Output Configurations

Eight levels of AC signal boost are provided in order to deliver maximum output power for many commonly-used SPKVDD/AVDD1 combinations. (Note that SPKVDD1 powers the Left Speaker driver, and SPKVDD2 powers the Right Speaker driver; it is assumed that SPKVDD1 = SPKVDD2 = SPKVDD.)

The signal boost options are available. The AC boost levels from 0dB to +12dB are selected using register bits SPKOUTL\_BOOST and SPKOUTR\_BOOST. To prevent pop noise, SPKOUTL\_BOOST and SPKOUTR\_BOOST should not be modified while the speaker outputs are enabled. Figure 31 illustrates the speaker outputs and the mixing and gain/boost options available.

Ultra-low leakage and high PSRR allow the speaker supply SPKVDD to be directly connected to a lithium battery. Note that an appropriate SPKVDD supply voltage must be provided to prevent waveform clipping when speaker boost is used.

DC gain is applied automatically, with a shift from VMID to SPKVDD/2. This provides optimum signal swing for maximum output power.

The AC and DC gain functions are illustrated in Figure 31.

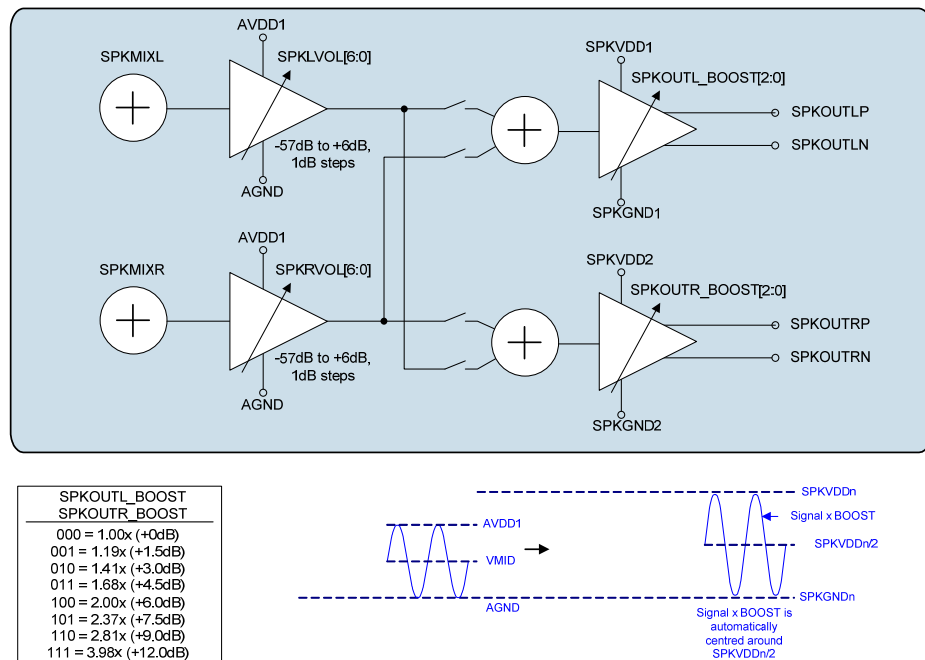

Figure 31 Speaker Output Configuration and AC Boost Operation

REGISTER ADDRESS	BIT	LABEL	DEFAULT	DESCRIPTION
R37 (0025h) ClassD	5:3	SPKOUTL_BOOST[2:0]	000 (1.0x)	Left Speaker Gain Boost 000 = 1.00x boost (+0dB) 001 = 1.19x boost (+1.5dB) 010 = 1.41x boost (+3.0dB) 011 = 1.68x boost (+4.5dB) 100 = 2.00x boost (+6.0dB) 101 = 2.37x boost (+7.5dB) 110 = 2.81x boost (+9.0dB) 111 = 3.98x boost (+12.0dB)
	2:0	SPKOUTR_BOOST[2:0]	000 (1.0x)	Right Speaker Gain Boost 000 = 1.00x boost (+0dB) 001 = 1.19x boost (+1.5dB) 010 = 1.41x boost (+3.0dB) 011 = 1.68x boost (+4.5dB) 100 = 2.00x boost (+6.0dB) 101 = 2.37x boost (+7.5dB) 110 = 2.81x boost (+9.0dB) 111 = 3.98x boost (+12.0dB)
R1825 (0721h) Pull Control (2)	1	SPKMODE_PU	1	SPKMODE Pull-up enable 0 = Disabled 1 = Enabled

**Table 72 Speaker Mode and Boost Control**

Clocking of the Class D output driver is derived from SYSCLK. The clocking frequency division is configured automatically, according to the AIFn\_SR and AIFnCLK\_RATE registers. (See "Clocking and Sample Rates" for further details of the system clocks and control registers.)

The Class D switching clock is enabled whenever SPKOUTL\_ENA or SPKOUTR\_ENA is set. The frequency is as described in Table 73.

When AIF1CLK is selected as the SYSCLK source (SYSCLK\_SRC = 0), then the Class D clock frequency is controlled by the AIF1\_SR and AIF1CLK\_RATE registers.

When AIF2CLK is selected as the SYSCLK source (SYSCLK\_SRC = 1), then the Class D clock frequency is controlled by the AIF2\_SR and AIF2CLK\_RATE registers.

The applicable clocks (SYSCLK, AIF1CLK or AIF2CLK) must be present and enabled when using the speaker outputs in Class D mode. The presence of a suitable clock is automatically detected by the WM1811A; if the clock signal is absent, then the speaker outputs will be disabled.

SAMPLE RATE (kHz)	SYSCLK RATE (AIFnCLK / fs ratio)							
	128	192	256	384	512	768	1024	1536
8	256	256	341.3	256	341.3	256	341.3	256
11.025	352.8	352.8	352.8	352.8	352.8	352.8	352.8	
12	384	384	384	384	384	384	384	
16	341.3	384	341.3	384	341.3	384		
22.05	352.8	352.8	352.8	352.8	352.8			
24	384	384	384	384	384			
32	341.3	384	341.3	384				
44.1	352.8	352.8	352.8					
48	384	384	384					
88.2	352.8							
96	384							

Table 73 Class D Switching Frequency (kHz)

### HEADPHONE OUTPUT CONFIGURATIONS

The headphone outputs HPOUT1L and HPOUT1R are driven by the headphone output PGAs HPOUT1LVOL and HPOUT1RVOL. Each PGA has its own dedicated volume control, as described in the “Analogue Output Signal Path” section. The input to these PGAs can be either the output mixers MIXOUTL and MIXOUTR or the direct DAC outputs DACL and DACR.

The headphone output driver is capable of driving up to 30mW into a 16Ω load or 25mW into a 32Ω load such as a stereo headset or headphones. The outputs are ground-referenced, eliminating any requirement for AC coupling capacitors. This is achieved by having separate positive and negative supply rails powered by an on-chip charge pump. A DC Servo circuit removes any DC offset from the headphone outputs, suppressing ‘pop’ noise and minimising power consumption. The Charge Pump and DC Servo are described separately (see “Charge Pump” and “DC Servo” respectively).

The typical headphone output connection is illustrated in Figure 32.

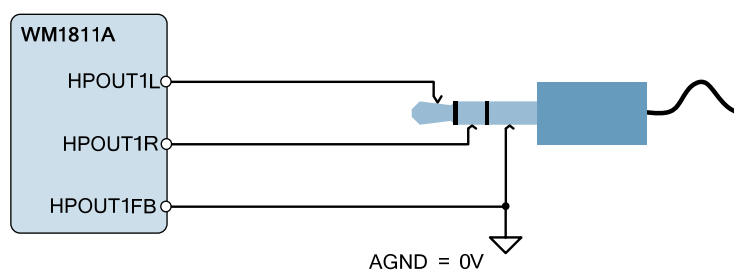

Figure 32 Headphone Output Configuration

The headphone output incorporates a common mode, or ground loop, feedback path which provides rejection of system-related ground noise. The return path is via HPOUT1FB. This pin must be connected to ground for normal operation of the headphone output. No register configuration is required.

Note that the HPOUT1FB pin should be connected to GND close to the headphone jack, as illustrated in Figure 32.



### EARPIECE DRIVER OUTPUT CONFIGURATIONS

The earpiece driver outputs HPOUT2P and HPOUT2N are driven by the HPOUT2MIX output mixer, which takes its inputs from the mixer output PGAs MIXOUTLVOL and MIXOUTRVOL. Fine volume control is available using MIXOUTLVOL and MIXOUTRVOL. A selectable -6dB attenuation is available on the HPOUT2MIX output, as described in Table 66 (refer to the “Analogue Output Signal Path” section).

The earpiece outputs are designed to operate in a BTL configuration, driving 50mW into a typical 16Ω ear speaker.

For suppression of pop noise there are two separate enables for the earpiece driver; HPOUT2\_ENA enables the output stage and HPOUT2\_IN\_ENA enables the mixer and input stage. HPOUT2\_IN\_ENA should be enabled a minimum of 50μs before HPOUT2\_ENA.

### LINE OUTPUT CONFIGURATIONS

The four line outputs LINEOUT1P, LINEOUT1N, LINEOUT2P and LINEOUT2N provide a highly flexible combination of differential and single-ended configurations, each driven by a dedicated output mixer. There is a selectable -6dB gain option in each mixer to avoid clipping when mixing more than one signal into a line output. Additional volume control is available at other locations within each of the supported signal paths. For more information about the line output mixing options, refer to the “Analogue Output Signal Path” section.

Typical applications for the line outputs (single-ended or differential) are:

- Handset or headset microphone output to external voice CODEC
- Stereo line output
- Output to external speaker driver(s) to support additional loudspeakers

When single-ended mode is selected for either LINEOUT1 or LINEOUT2, a buffered VMID must be enabled as a reference for the outputs. This is enabled by setting the LINEOUT\_VMID\_BUF\_ENA bit as defined in Table 74.

REGISTER ADDRESS	BIT	LABEL	DEFAULT	DESCRIPTION
R56 (0038h) AntiPOP (1)	7	LINEOUT_VMID_BUF_ENA	0	Enables VMID reference for line outputs in single-ended mode 0 = Disabled 1 = Enabled

**Table 74 LINEOUT VMID Buffer for Single-Ended Operation**

Some example line output configurations are listed and illustrated below.

- Differential line output from Mic/Line input on IN1L PGA
- Differential line output from Mic/Line input on IN1R PGA
- Stereo differential line output from output mixers MIXOUTL and MIXOUTR
- Stereo single-ended line output from output mixer to either LINEOUT1 or LINEOUT2
- Mono single-ended line output from output mixer

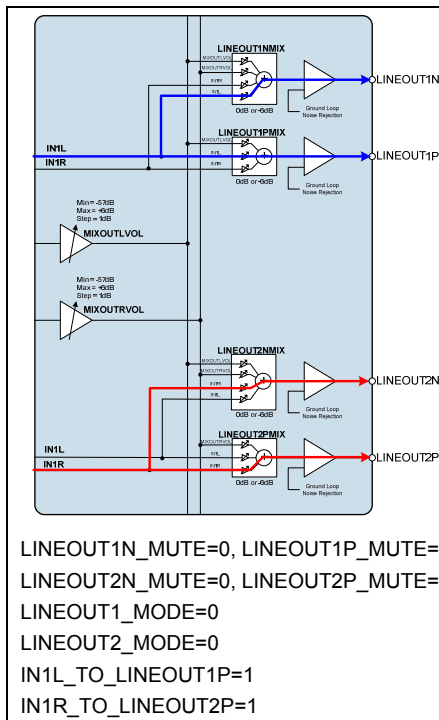

**Figure 33 Differential Line Out from input PGA IN1L (to LINEOUT1) and IN1R (to LINEOUT2)**

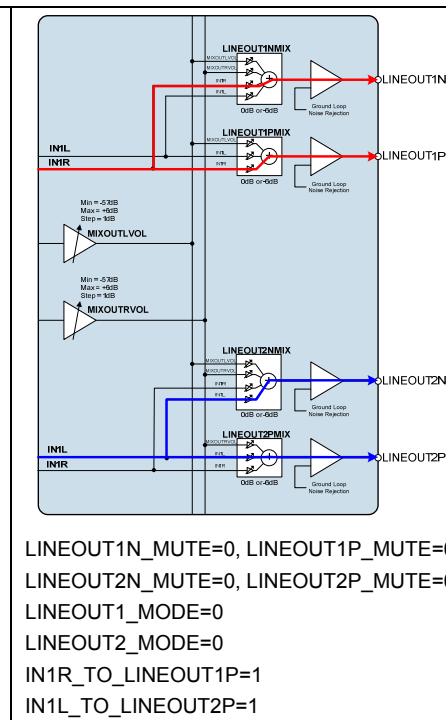

**Figure 34 Differential Line Out from input PGA IN1R (to LINEOUT1) and IN1L (to LINEOUT2)**

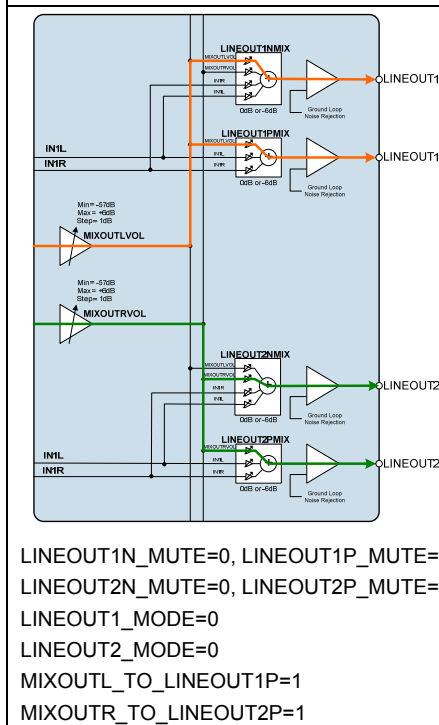

**Figure 35 Stereo Differential Line Out from MIXOUTL and MIXOUTR**

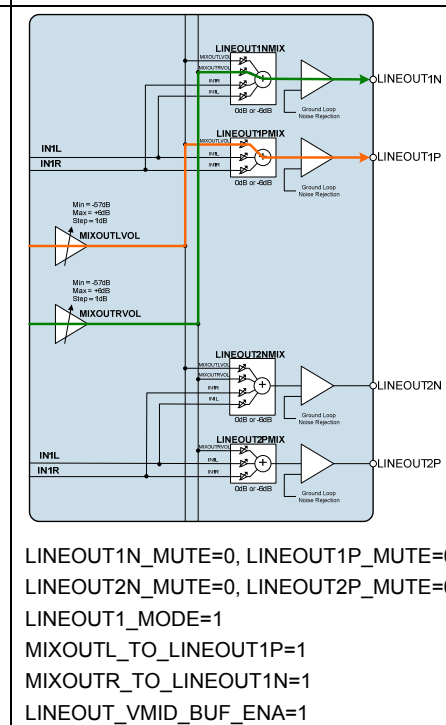

**Figure 36 Stereo Single-Ended Line Out from MIXOUTL and MIXOUTR to LINEOUT1**

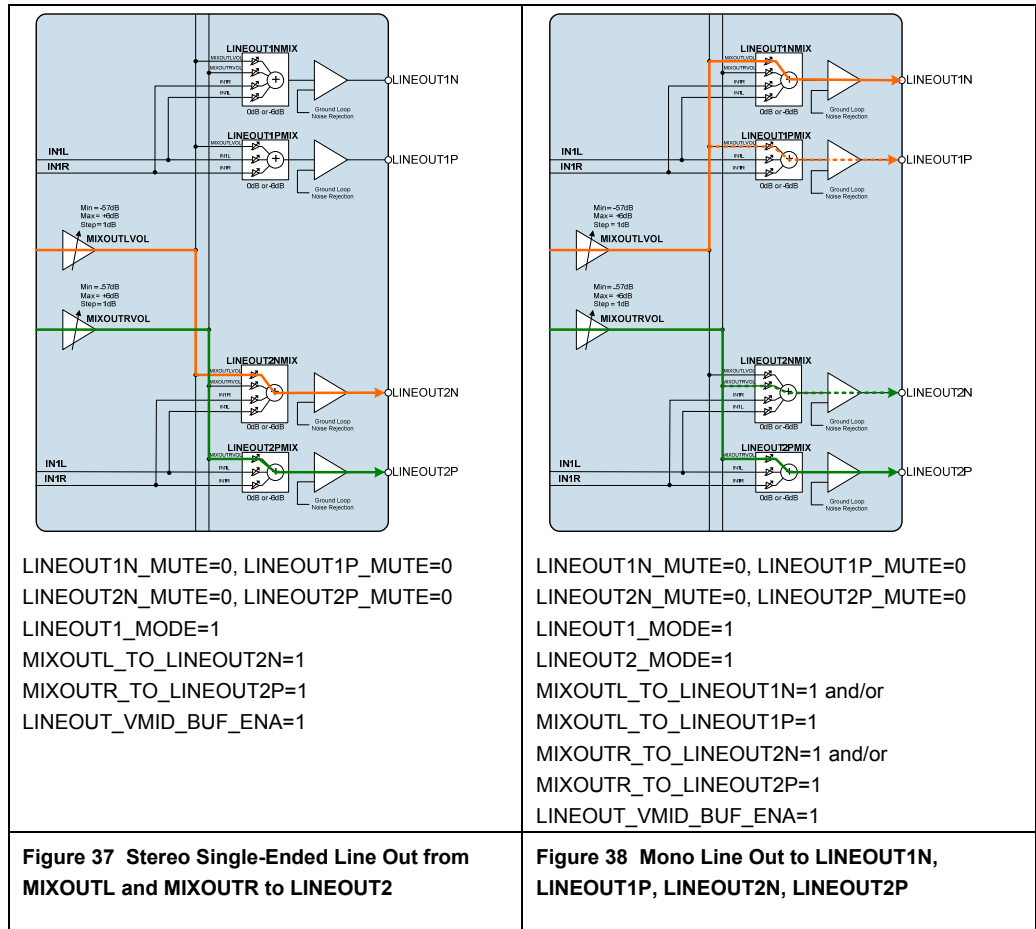

The line outputs incorporate a common mode, or ground loop, feedback path which provides rejection of system-related ground noise. The return path, via LINEOUTFB, is enabled separately for LINEOUT1 and LINEOUT2 using the LINEOUT1\_FB and LINEOUT2\_FB bits as defined in Table 75.

Ground loop feedback is a benefit to single-ended line outputs only; it is not applicable to differential outputs, which already inherently offer common mode noise rejection.

REGISTER ADDRESS	BIT	LABEL	DEFAULT	DESCRIPTION
R55 (0037h) Additional Control	7	LINEOUT1_FB	0	Enable ground loop noise feedback on LINEOUT1 0 = Disabled 1 = Enabled
	6	LINEOUT2_FB	0	Enable ground loop noise feedback on LINEOUT2 0 = Disabled 1 = Enabled

Table 75 Line Output Ground Loop Feedback Enable

## EXTERNAL ACCESSORY DETECTION

The WM1811A provides external accessory detection functions which can sense the presence and impedance of external components. This can be used to detect the insertion or removal of an external headphone or headset, and to provide an indication of key/button push events.

Jack insertion is detected using the JACKDET pin, which must be connected to switch contacts within the jack socket. An Interrupt event is generated whenever a jack insertion or jack removal event is detected.

Microphones, push-buttons and other accessories can be detected via the MICDET pin. The presence of a microphone, and the status of a hookswitch can be detected. This feature can also be used to detect push-button operation.

Note that clocking is required for all of the external accessory detection functions. The WM1811A can support accessory detection using a low frequency (eg. 32kHz) clock for reduced power consumption.

### JACK DETECT

The WM1811A provides support for jack insertion switch detection. The Jack Detect function also enables the device to be configured for low power standby modes; typical use cases are where an application is idle in standby mode until a headphone or headset jack is inserted.

Jack insertion and removal is detected using the JACKDET pin. The recommended external connection circuit is illustrated in Figure 39. The status of the jack insertion switch can be read using the JACKDET\_LVL register.

The JACKDET input de-bounce is enabled or disabled using the JACKDET\_DB register, as described in Table 77.

The Jack Detect function is enabled whenever JACKDET\_MODE > 00. An Interrupt Request (IRQ) event is generated whenever a jack insertion or jack removal is detected (see "Interrupts").

Different settings of JACKDET\_MODE allow different low power configurations to be selected. Note that audio and/or microphone detection functions are not supported under these low power conditions. The options provided by the JACKDET\_MODE register are summarised in Table 76.

When JACKDET\_MODE = 01, the LDO1 regulator output must be configured to be floating when disabled. The LDO1\_DISCH bit (see Table 127) must be set to 0 before setting JACKDET\_MODE = 01.

Note that, in modes where MICDET (microphone / accessory detect) functionality is required, this must be configured as described in the following section. In modes where the Audio functions are not supported, none of the WM1811A analogue/digital audio record or playback functions are possible.

JACKDET_MODE	JACK DETECT	MICROPHONE / ACCESSORY DETECT	AUDIO FUNCTIONS	TYPICAL USE CASE
00		✓	✓	Full device operation (eg. audio record/playback). (Note that Jack Detect is not supported.)
01	✓	✓		Device in idle mode, monitoring accessory activity (eg. button press, jack removal etc.)
10	✓			Device in standby mode, awaiting jack insertion - Lowest power external accessory detection mode.
11	✓	✓	✓	Full device operation (eg. audio record/playback).

Note that JACKDET\_MODE = 01 or 10 are not supported if AVDD1 or DCVDD is supplied externally.  
These settings must not be selected if AVDD1 or DCVDD is supplied externally (ie. if LDO1 or LDO2 is not used).

**Table 76 Jack Detect Modes**

When JACKDET\_MODE = 01, LDO1 and LDO2 are disabled. AVDD1 is powered from AVDD2, and DCVDD is powered from DBVDD1.

When JACKDET\_MODE = 10, LDO1 and LDO2 are disabled. AVDD1 is unpowered, and DCVDD is powered from DBVDD1.

Note that, in both modes described above, the LDO1ENA input pin is ignored. The LDO2ENA pin must be asserted (logic '1') to power DCVDD, although LDO2 will operate in a 'bypass' mode, connecting DCVDD to DBVDD1.

Note that, in both modes described above, the AVDD1 voltage is below the minimum recommended operating level. Analogue or digital audio functions cannot be supported in these modes.

Note that the LDO configuration for JACKDET\_MODE = 01 or 10 assumes that AVDD1 and DCVDD are powered from LDO1 and LDO2 respectively. If AVDD1 or DCVDD is powered externally (not from the internal LDOs), then these settings of JACKDET\_MODE must not be used.

If AVDD1 or DCVDD is powered externally (not from the internal LDOs), then the Jack Detect function, when required, should be enabled by setting JACKDET\_MODE = 11.

The control registers associated with the Jack Detect function are described in Table 77.

REGISTER ADDRESS	BIT	LABEL	DEFAULT	DESCRIPTION
R1797 (0705h) JACKDET Ctrl	8	JACKDET_DB	1	JACKDET input de-bounce 0 = Disabled 1 = Enabled
	6	JACKDET_LVL	0	JACKDET input status 0 = Jack not detected 1 = Jack is detected
R57 (39h) AntiPOP (2)	8:7	JACKDET_MODE	00	JACKDET mode select 00 = Jack Detect disabled 01 = Jack Detect enabled 10 = Jack Detect enabled 11 = Jack Detect enabled  MICDET (microphone/accessory detection) is not supported when JACKDET_MODE = 10. Analogue/Digital audio functions are not supported when JACKDET_MODE = 01 or 10.  LDO1_DISCH must be set to 0 when JACKDET_MODE=01.  Settings 01 and 10 must not be selected if AVDD1 or DCVDD is supplied externally (ie. if LDO1 or LDO2 is not used).

**Table 77 Jack Detect Control**

Clocking for the jack detection function is derived from SYSCLK (defined in the "Clocking and Sample Rates" section). The WM1811A can support accessory detection using a low frequency (eg. 32kHz) clock for reduced power consumption. See the "External Accessory Detection Clocking" section below for further details.

To configure the WM1811A in its lowest power condition, also supporting the Jack Detect function, the following actions are recommended:

- Select lowest power Jack Detection mode (JACKDET\_MODE = 10)
- Select 32kHz SYSCLK
- Disable the Thermal sensor (TSHUT\_ENA = 0)
- Configure LDO1 output to float when disabled (LDO1\_DISCH = 0)
- Minimise any static current leakage paths on digital inputs where internal pull-up or pull-down resistors are enabled (ie. disable the pull-up/pull-down resistors on these inputs)

Care should be taken to restore all applicable device settings when normal operation is resumed following the low power jack detection. In particular, note that the thermal sensor should be enabled for normal operation.

A recommended connection circuit, including headphone output on HPOUT1 and microphone connections, is shown in Figure 39. See “Applications Information” for details of recommended external components.

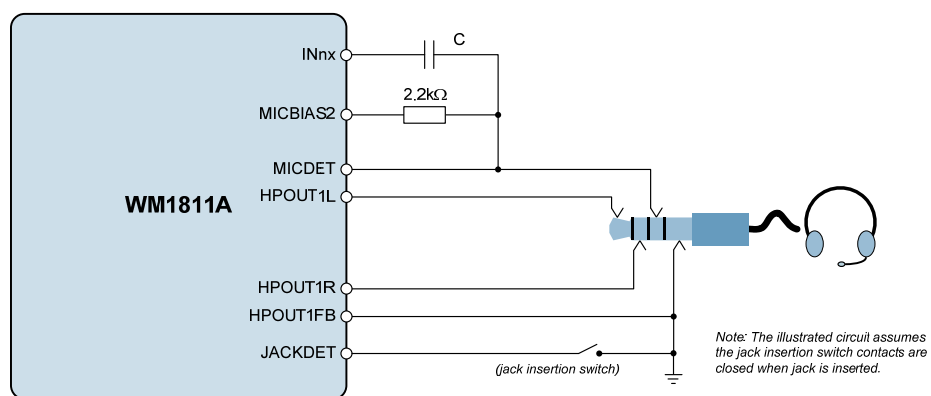

**Figure 39 Jack Detect and External Accessory Connections**

The internal comparator circuit used to detect the JACKDET status is illustrated in Figure 40.

The threshold voltages for the jack detect circuit are noted in the “Electrical Characteristics”. Note that separate thresholds are defined for jack insertion and jack removal.

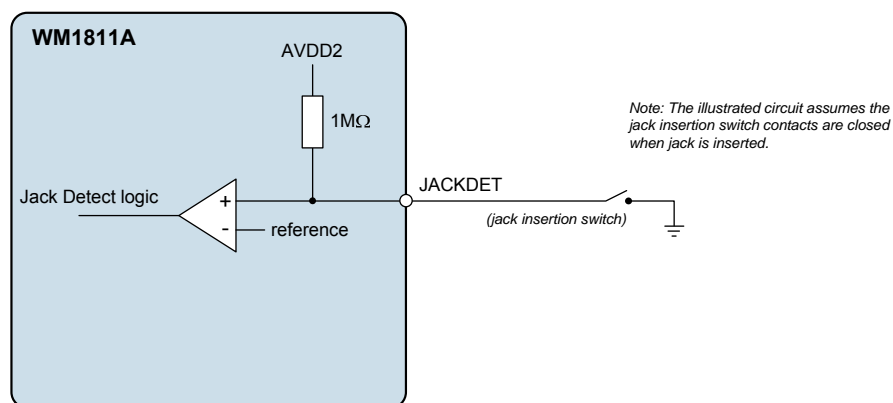

**Figure 40 Jack Detect Comparator**

## MICROPHONE / ACCESSORY DETECT

The WM1811A accessory detection circuit measures the impedance of an external load connected to the MICDET pin. This feature can be used to detect the insertion or removal of a microphone, and the status of the associated hookswitch. It can also be used to detect push-button status or the connection of other external accessories.

The microphone detection circuit measures the impedance connected to MICDET, and reports whether the measured impedance lies within one of 9 pre-defined levels (including the 'no accessory detected' level). This means it can detect the presence of a typical microphone and up to 7 push-buttons. One of the impedance levels is specifically designed to detect a video accessory (typical 75 $\Omega$ ) load if required.

The microphone detection circuit uses the MICBIAS2 output as a reference. The WM1811A will automatically enable MICBIAS2 when required in order to perform the detection function; this allows the detection function to be supported in low-power standby operating conditions.

Microphone detection is enabled by setting the MICD\_ENA register. When microphone detection is enabled, the WM1811A performs a number of measurements in order to determine the MICDET impedance. The measurement process is repeated at a cyclic rate controlled by MICD\_RATE. (The MICD\_RATE register selects the delay between completion of one measurement and the start of the next.)

For best accuracy, the measured impedance is only deemed valid after more than one successive measurement has produced the same result. The MICD\_DBTIME register provides control of the de-bounce period; this can be either 2 measurements or 4 measurements.

When the microphone detection result has settled (ie. after the applicable de-bounce period), the WM1811A indicates valid data by setting the MICD\_VALID bit. The measured impedance is indicated using the MICD\_LVL and MICD\_STS register bits, as described in Table 78.

The MICD\_VALID bit, when set, remains asserted for as long as the microphone detection function is enabled (ie. while MICD\_ENA = 1). If the detected impedance changes, then the MICD\_LVL and MICD\_STS fields will change, but the MICD\_VALID bit will remain set, indicating valid data at all times.

Note that the impedance levels quoted in the MICD\_LVL description assume that a microphone (475 $\Omega$  to 30k $\Omega$  impedance) is also present on the MICDET pin. The limits quoted in the "Electrical Characteristics" refer to the combined effective impedance on the MICDET pin. Typical external components are described in the "Applications Information" section.

The microphone detection reports a measurement result in one of the pre-defined impedance levels. Each measurement level can be enabled or disabled independently; this provides flexibility according to the required thresholds, and offers a faster measurement time in some applications. The MICD\_LVL\_SEL register is described in detail later in this section.

Clocking for the microphone detection function is derived from SYSCLK (defined in the "Clocking and Sample Rates" section). The WM1811A can support accessory detection using a low frequency (eg. 32kHz) clock for reduced power consumption. See the "External Accessory Detection Clocking" section below for further details.

The microphone detection function is an input to the Interrupt control circuit and can be used to trigger an Interrupt event every time an accessory insertion, removal or impedance change is detected. See "Interrupts" for further details.

The microphone detection function can also generate a GPIO output, providing an external indication of the microphone detection. This GPIO output is pulsed every time an accessory insertion, removal or impedance change is detected. See "General Purpose Input/Output" for details of how to configure a GPIO pin to output the microphone detection signal.

The register fields associated with Microphone Detection (or other accessories) are described in Table 78. The external circuit configuration is illustrated in Figure 41.

REGISTER ADDRESS	BIT	LABEL	DEFAULT	DESCRIPTION
R208 (00D0h) Mic Detect 1	15:12	MICD_BIAS_START TIME [3:0]	0111	Mic Detect Bias Startup Delay (If MICBIAS2 is not enabled already, this field selects the delay time allowed for MICBIAS2 to startup prior to performing the MICDET function.) 0000 = 0ms (continuous) 0001 = 0.25ms 0010 = 0.5ms 0011 = 1ms 0100 = 2ms 0101 = 4ms 0110 = 8ms 0111 = 16ms 1000 = 32ms 1001 = 64ms 1010 = 128ms 1011 = 256ms 1100 to 1111 = 512ms
	11:8	MICD_RATE [3:0]	0110	Mic Detect Rate (Selects the delay between successive Mic Detect measurements.) 0000 = 0ms (continuous) 0001 = 0.25ms 0010 = 0.5ms 0011 = 1ms 0100 = 2ms 0101 = 4ms 0110 = 8ms 0111 = 16ms 1000 = 32ms 1001 = 64ms 1010 = 128ms 1011 = 256ms 1100 to 1111 = 512ms
	1	MICD_DBTIME	0	Mic Detect De-bounce 0 = 2 measurements 1 = 4 measurements
	0	MICD_ENA	0	Mic Detect Enable 0 = Disabled 1 = Enabled  Note that Mic Detect is not supported when JACKDET_MODE = 10.



REGISTER ADDRESS	BIT	LABEL	DEFAULT	DESCRIPTION
R209 (00D1h) Mic Detect 2	7:0	MICD_LVL_SEL [7:0]	0111_ 1111	Mic Detect Level Select (enables Mic Detection in specific impedance ranges) [7] = Not used - must be set to 0 [6] = Enable >475 ohm detection [5] = Enable 326 ohm detection [4] = Enable 152 ohm detection [3] = Enable 77 ohm detection [2] = Enable 47.6 ohm detection [1] = Enable 29.4 ohm detection [0] = Enable 14 ohm detection Note that the impedance values quoted assume that a microphone (475ohm-30kohm) is also present on the MICDET pin.
R210 (00D2h) Mic Detect 3	10:2	MICD_LVL [8:0]	0_0000_ 0000	Mic Detect Level (indicates the measured impedance) [8] = Not used [7] = >475 ohm, <30k ohm [6] = 326 ohm [5] = 152 ohm [4] = 77 ohm [3] = 47.6 ohm [2] = 29.4 ohm [1] = 14 ohm [0] = <3 ohm Note that the impedance values quoted assume that a microphone (475ohm-30kohm) is also present on the MICDET pin.
	1	MICD_VALID	0	Mic Detect Data Valid 0 = Not Valid 1 = Valid
	0	MICD_STS	0	Mic Detect Status 0 = No Mic Accessory present (impedance is >30k ohm) 1 = Mic Accessory is present (impedance is <30k ohm)

Table 78 Microphone Detect Control

The external connections for the Microphone Detect circuit are illustrated in Figure 41. In typical applications, it can be used to detect a microphone or button press.

The microphone detection function uses MICBIAS2 as a reference. The microphone detection function will automatically enable MICBIAS2 when required for MICDET impedance measurement.

If MICBIAS2 is not already enabled (ie. if MICB2\_ENA = 0), then MICBIAS2 will be enabled for short periods of time only, every time the impedance measurement is scheduled. To allow time for the MICBIAS2 source to start-up, a time delay is applied before the measurement is performed; this is configured using the MICD\_BIAS\_STARTTIME register, as described in Table 78.

The MICD\_BIAS\_STARTTIME register should be set to 16ms or more if MICB2\_RATE = 1 (pop-free start-up / shut-down). The MICD\_BIAS\_STARTTIME register should be set to 0.25ms or more if MICB2\_RATE = 0 (fast start-up / shut-down).

If the MICBIAS2 reference is not enabled continuously (ie. if MICB2\_ENA = 0), then the MICBIAS2 discharge bit (MICB2\_DISCH) should be set to 0.

The MICBIAS sources are configured using the registers described in Table 1, in the “Analogue Input Signal Path” section.

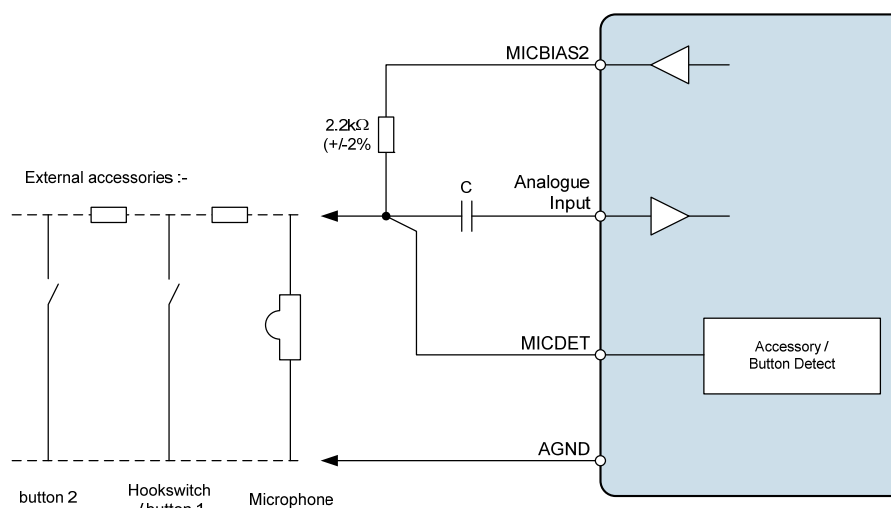

**Figure 41 Microphone Detect Interface**

The MICD\_LVL\_SEL [7:0] register bits allow each of the impedance measurement levels to be enabled or disabled independently. This allows the function to be tailored to the particular application requirements.

If one or more bits within the MICD\_LVL\_SEL register is set to 0, then the corresponding impedance level will be disabled. Any measured impedance which lies in a disabled level will be reported as the next lowest, enabled level.

For example, the MICD\_LVL\_SEL [3] bit enables the detection of impedances around 77Ω. If MICD\_LVL\_SEL [3] = 0, then an external impedance of 77Ω will not be indicated as 77Ω but will be indicated as 47Ω; this would be reported in the MICD\_LVL register as MICD\_LVL [3] = 1.

With all measurement levels enabled, the WM1811A can detect the presence of a typical microphone and up to 7 push-buttons. The microphone detect function is specifically designed to detect a video accessory (typical 75Ω) load if required.

See “Applications Information” for typical recommended external components for microphone, video or push-button accessory detection.

The microphone detection circuit assumes that a 2.2kΩ(2%) resistor is connected to MICBIAS2, as illustrated. Different resistor values will lead to inaccuracy in the impedance measurement.

The measurement accuracy of the microphone detect function is assured whenever the connected load is within the applicable limits specified in the “Electrical Characteristics”. Note that a 2.2kΩ (2%) resistor must also be connected between MICDET and MICBIAS2.

Note that the connection of a microphone will change the measured impedance on the MICDET pin; see “Applications Information” for recommended components for typical applications.

The measurement time varies between 100µs and 500µs according to the impedance of the external load. A high impedance will be measured faster than a low impedance.

The timing of the microphone detect function is illustrated in Figure 42. Two different cases are shown, according to whether MICBIAS2 is enabled periodically by the impedance measurement function (MICB2\_ENA=0), or is enabled at all times (MICB2\_ENA=1).

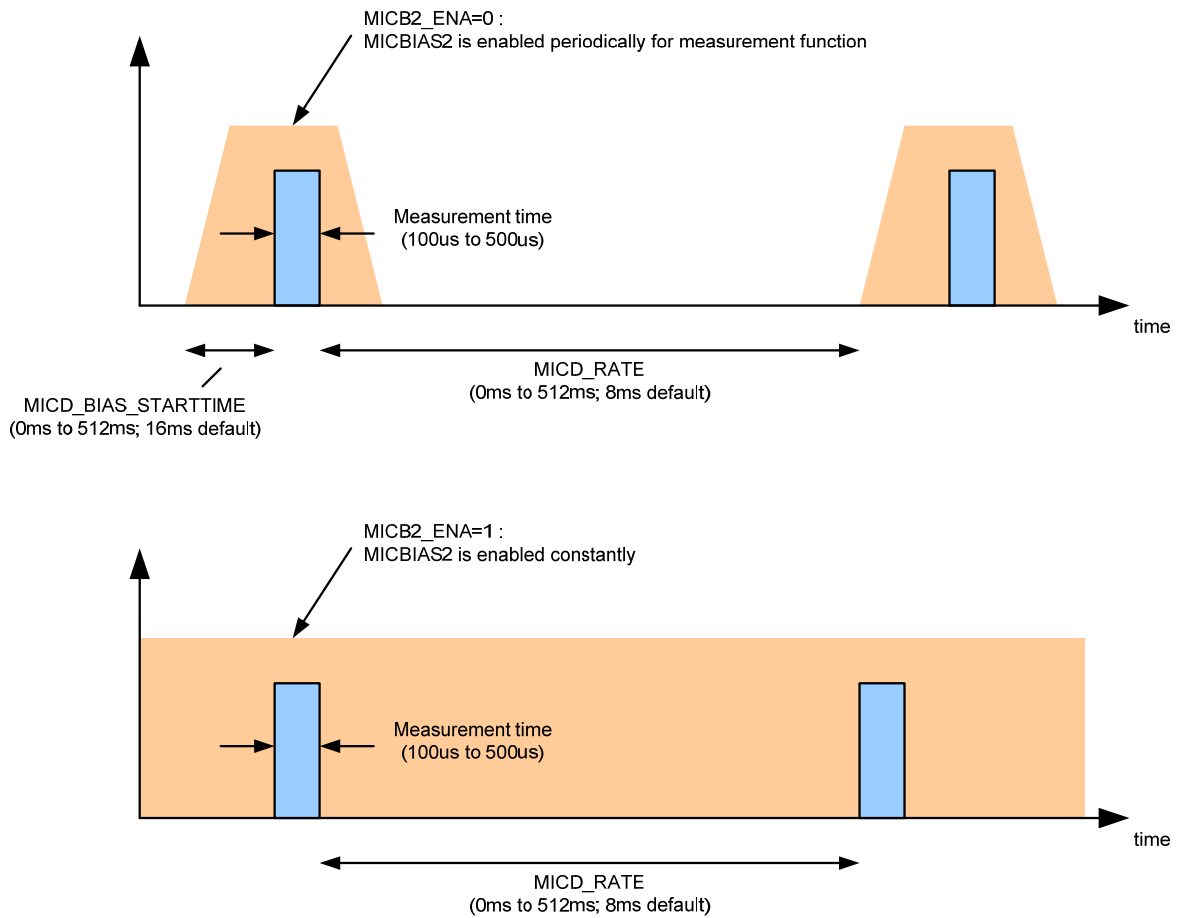

Figure 42 Microphone Detect Timing

### EXTERNAL ACCESSORY DETECTION CLOCKING

Clocking for the jack detect and microphone detection functions is derived from SYSCLK (defined in the "Clocking and Sample Rates" section).

When AIF1CLK is selected as the SYSCLK source (SYSCLK\_SRC = 0), then AIF1CLK must be present and enabled when using the external accessory detect functions. The AIF1\_SR and AIF1CLK\_RATE registers must be set to values that are consistent with the available AIF1CLK frequency.

When AIF2CLK is selected as the SYSCLK source (SYSCLK\_SRC = 1), then AIF2CLK must be present and enabled when using the external accessory detect functions. The AIF2\_SR and AIF2CLK\_RATE registers must be set to values that are consistent with the available AIF2CLK frequency.

The accessory detection functions can also be supported using a low frequency (eg. 32kHz) clock, as described below - see "External Accessory Detection with Low Frequency SYSCLK".

The Frequency Locked Loop (FLL) free-running mode provides flexibility to clock the accessory detection functions without any external reference clock, eg. in low-power standby operating conditions. See "Clocking and Sample Rates" for details of the WM1811A clocking options and FLL.

### EXTERNAL ACCESSORY DETECTION WITH LOW FREQUENCY SYSCLK

Clocking for the jack detect and microphone detection function can be derived from AIF1CLK or AIF2CLK, as described earlier.

Under normal circumstances, the AIFn\_SR and AIFnCLK\_RATE registers must be set to values that are consistent with the available AIFnCLK frequency. The register settings support AIFnCLK frequencies of 1.024MHz or higher.

The microphone detection function can also be supported using a low frequency (eg. 32kHz) clock. In this case, the selected SYSCLK source (AIF1CLK or AIF2CLK) should be configured with the following register settings:

- AIFnCLK\_RATE = 0001 (AIFnCLK / fs = 128)
- AIFn\_SR = 0000 (fs = 8kHz)

The register settings above configure the WM1811A for AIFnCLK = 1.024MHz. If the available clock is a different frequency (eg. 32kHz), then the timings set by the MICD\_RATE and MICD\_BIAS\_STARTUP registers will be scaled accordingly. In the case of a 32kHz clock, these times will be extended by a factor of 32 (calculated as 1024000 / 32000).

For example, under normal circumstances, setting MICD\_RATE = 0011 selects a 1ms delay between successive measurements. Using a 32kHz reference clock, and the register settings above, then MICD\_RATE = 0011 will select a 32ms delay.

## GENERAL PURPOSE INPUT/OUTPUT

The WM1811A provides a number of GPIO functions to enable interfacing and detection of external hardware and to provide logic outputs to other devices. The input functions can be polled directly or can be used to generate an Interrupt (IRQ) event. The GPIO and Interrupt circuits support the following functions:

- Alternate interface functions (AIF3)
- Button detect (GPIO input)
- Logic '1' and logic '0' output (GPIO output)
- Interrupt (IRQ) status output
- Over-Temperature detection
- Microphone accessory status detection
- Frequency Locked Loop (FLL) Lock status output
- Sample Rate Conversion (SRC) Lock status output
- Dynamic Range Control (DRC) Signal activity detection
- Digital Core FIFO error status output
- Clock output (SYSCLK divided by OPCLK\_DIV)
- Frequency Locked Loop (FLL) Clock output

### GPIO CONTROL

For each GPIO, the selected function is determined by the GPn\_FN field, where n identifies the GPIO pin (1, 8, 9, 10, 11). The pin direction, set by GPn\_DIR, must be set according to function selected by GPn\_FN.

The digital audio interface AIF3 is supported using GPIO pins; the applicable pin functions are selected by setting the corresponding GPn\_FN register to 00h. The ADCLRCLK1 function for AIF1 is supported on GPIO1. See Table 80 for the definition of which AIF function is available on each GPIO pin.

See "Digital Audio Interface Control" for details of AIF2 and AIF3.

When a pin is configured as a GPIO input (GPn\_DIR = 1), the logic level at the pin can be read from the respective GPn\_LVL bit. Note that GPn\_LVL is not affected by the GPn\_POL bit.

A de-bounce circuit can be enabled on any GPIO input, to avoid false event triggers. This is enabled on each pin by setting the respective GPn\_DB bit.

When a pin is configured as a Logic Level output (GPn\_DIR = 0, GPn\_FN = 01h), its level can be set to logic 0 or logic 1 using the GPn\_LVL field.

When a pin is configured as an output (GPn\_DIR = 0), the polarity can be inverted using the GPn\_POL bit. When GPn\_POL = 1, then the selected output function is inverted. In the case of Logic Level output (GPn\_FN = 01h), the external output will be the opposite logic level to GPn\_LVL when GPn\_POL = 1.

A GPIO output can be either CMOS driven or Open Drain. This is selected on each pin using the respective GPn\_OP\_CFG bit.

Internal pull-up and pull-down resistors may be enabled using the GPn\_PU and GPn\_PD fields; this allows greater flexibility to interface with different signals from other devices. (Note that if GPn\_PU and GPn\_PD are both set for any GPIO pin, then the pull-up and pull-down will be disabled.)

Each of the GPIO pins is an input to the Interrupt control circuit and can be used to trigger an Interrupt event. An interrupt event is triggered on the rising and falling edge of the GPIO input. The associated interrupt bit is latched once set; it can be polled at any time or used to control the IRQ signal. See "Interrupts" for more details of the Interrupt event handling.

The register fields that control the GPIO pins are described in Table 79.

REGISTER ADDRESS	BIT	LABEL	DEFAULT	DESCRIPTION
R1792 (0700h) GPIO1	15	GPn_DIR	1	GPIO Pin Direction 0 = Output 1 = Input
R1799 (0707h) GPIO8	14	GPn_PU	0	GPIO Pull-Up Enable 0 = Disabled 1 = Enabled
to	13	GPn_PD	1	GPIO Pull-Down Enable 0 = Disabled 1 = Enabled
R1802 (070Ah) GPIO11	10	GPn_POL	0	GPIO Polarity Select 0 = Non-inverted (Active High) 1 = Inverted (Active Low)
	9	GPn_OP_CFG	0	GPIO Output Configuration 0 = CMOS 1 = Open Drain
	8	GPn_DB	1	GPIO Input De-bounce 0 = Disabled 1 = Enabled
	6	GPn_LVL	0	GPIO level. Write to this bit to set a GPIO output. Read from this bit to read GPIO input level. For output functions only, when GPn_POL is set, the register contains the opposite logic level to the external pin.
	4:0	GPn_FN [4:0]		GPIO Pin Function (see Table 80 for details) GP1_FN default = 0000 GP8_FN default = 0001 GP9_FN default = 0001 GP10_FN default = 0001 GP11_FN default = 0001
<b>Note:</b> <i>n</i> is a number (1, 8, 9, 10, 11) that identifies the individual GPIO.				

**Table 79 GPIO1, GPIO8, GPIO9, GPIO10 to GPIO11 Control**

### GPIO FUNCTION SELECT

The available GPIO functions are described in Table 80. The function of each GPIO is set using the GPn\_FN register, where *n* identifies the GPIO pin (1, 8, 9, 10, 11). Note that the respective GPn\_DIR must also be set according to whether the function is an input or output.

GPn_FN	DESCRIPTION	COMMENTS
00h	GPIO1 - ADCLRCLK1 GPIO8 - DACDAT3 GPIO9 - ADCDAT3 GPIO10 - LRCLK3 GPIO11 - BCLK3	Alternate Audio Interface connections.
01h	Button detect input / Logic level output	GPn_DIR = 0: GPIO pin logic level is set by GPn_LVL. GPn_DIR = 1: Button detect or logic level input.
02h	Reserved	
03h	IRQ	Interrupt (IRQ) output 0 = IRQ not asserted 1 = IRQ asserted

GPn_FN	DESCRIPTION	COMMENTS
04h	Temperature (Shutdown) status output	Indicates Temperature Shutdown Sensor status 0 = Temperature is below shutdown level 1 = Temperature is above shutdown level
05h	Microphone Detect	Microphone Detect (MICDET accessory) IRQ output A single 31 $\mu$ s pulse is output whenever an accessory insertion, removal or impedance change is detected.
06h	Reserved	
07h	Reserved	
08h	Reserved	
09h	FLL1 Lock	Indicates FLL1 Lock status 0 = Not locked 1 = Locked
0Ah	FLL2 Lock	Indicates FLL2 Lock status 0 = Not locked 1 = Locked
0Bh	SRC1 Lock	Indicates SRC1 Lock status 0 = Not locked 1 = Locked
0Ch	SRC2 Lock	Indicates SRC2 Lock status 0 = Not locked 1 = Locked
0Dh	AIF1 DRC1 Signal Detect	Indicates AIF1 DRC Signal Detect status 0 = Signal threshold not exceeded 1 = Signal threshold exceeded
0Eh	Reserved	
0Fh	AIF2 DRC Signal Detect	Indicates AIF2 DRC Signal Detect status 0 = Signal threshold not exceeded 1 = Signal threshold exceeded
10h	Reserved	
11h	FIFO Error	Indicates a Digital Core FIFO Error condition 0 = Normal operation 1 = FIFO Error
12h	Clock Output OPCLK	GPIO Clock derived from SYSCLK
13h	Temperature (Warning) status output	Indicates Temperature Warning Sensor status 0 = Temperature is below warning level 1 = Temperature is above warning level
14h	DC Servo Done	Indicates DC Servo status on HPOUT1L and HPOUT1R 0 = DC Servo not complete 1 = DC Servo complete
15h	FLL1 Clock Output	Clock output from FLL1
16h	FLL2 Clock Output	Clock output from FLL2
17h to 1Fh	Reserved	

Table 80 GPIO Function Select

### BUTTON DETECT (GPIO INPUT)

Button detect functionality can be selected on any GPIO pin by setting the respective GPIO registers as described in "GPIO Control". The same functionality can be used to support a Jack Detect input function.

It is recommended to enable the GPIO input de-bounce feature when using GPIOs as button input or Jack Detect input.

The GPN\_LVL fields may be read to determine the logic levels on a GPIO input, after the selectable de-bounce controls. Note that GPN\_LVL is not affected by the GPN\_POL bit.

The de-bounced GPIO signals are also inputs to the Interrupt control circuit. An interrupt event is triggered on the rising and falling edge of the GPIO input. The associated interrupt bits are latched once set; it can be polled at any time or used to control the IRQ signal. See "Interrupts" for more details of the Interrupt event handling.

### LOGIC '1' AND LOGIC '0' OUTPUT (GPIO OUTPUT)

The WM1811A can be programmed to drive a logic high or logic low level on any GPIO pin by selecting the "GPIO Output" function as described in "GPIO Control". The output logic level is selected using the respective GPN\_LVL bit.

Note that the polarity of the GPIO output can be inverted using the GPN\_POL registers. If GPN\_POL = 1, then the external output will be the opposite logic level to GPN\_LVL.

### INTERRUPT (IRQ) STATUS OUTPUT

The WM1811A has an Interrupt Controller which can be used to indicate when any selected Interrupt events occur. An interrupt can be generated by any of the events described throughout the GPIO function definition above. Individual interrupts may be masked in order to configure the Interrupt as required. See "Interrupts" for further details.

The Interrupt (IRQ) status may be output directly on any GPIO pin by setting the respective GPIO registers as described in "GPIO Control".

### OVER-TEMPERATURE DETECTION

The WM1811A incorporates a temperature sensor which detects when the device temperature is within normal limits or if the device is approaching a hazardous temperature condition.

The Temperature status may be output directly on any GPIO pin by setting the respective GPIO registers as described in "GPIO Control". Any GPIO pin can be used to indicate either a Warning Temperature event or the Shutdown Temperature event. De-bounce can be applied to the applicable signal using the register bits described in Table 81.

The Warning Temperature and Shutdown Temperature status are inputs to the Interrupt control circuit, after the selectable de-bounce. An interrupt event may be triggered on the rising and falling edges of these signals. The associated interrupt bit is latched once set; it can be polled at any time or used to control the IRQ signal. See "Interrupts" for more details of the Interrupt event handling.

Note that the temperature sensor can be configured to automatically disable the audio outputs of the WM1811A (see "Thermal Shutdown"). In some applications, it may be preferable to manage the temperature sensor event through GPIO or Interrupt functions, allowing a host processor to implement a controlled system response to an over-temperature condition.

The temperature sensor must be enabled by setting the TSHUT\_ENA register bit. When the TSHUT\_OPDIS is also set, then a device over-temperature condition will cause the speaker outputs (SPKOUTL and SPKOUTR) of the WM1811A to be disabled.



REGISTER ADDRESS	BIT	LABEL	DEFAULT	DESCRIPTION
R2 (0002h) Power Management (2)	14	TSHUT_EN A	1	Thermal sensor enable 0 = Disabled 1 = Enabled
	13	TSHUT_OP DIS	1	Thermal shutdown control (Causes audio outputs to be disabled if an overtemperature occurs. The thermal sensor must also be enabled.) 0 = Disabled 1 = Enabled
R1864 (0748h) IRQ Debounce	0	TEMP_WAR N_DB	0	Thermal Warning de-bounce 0 = Disabled 1 = Enabled
	0	TEMP_SHU T_DB	0	Thermal shutdown de-bounce 0 = Disabled 1 = Enabled

Table 81 Temperature Sensor Enable and GPIO/Interrupt Control

### MICROPHONE ACCESSORY STATUS DETECTION

The WM1811A provides an impedance measurement circuit on the MICDET pin to detect the connection of a microphone or other external accessory. See “External Accessory Detection” for further details.

A logic signal from the microphone detect circuit may be output directly on any GPIO pin by setting the respective GPIO registers as described in “GPIO Control”. This logic signal is set high for a single pulse duration of 31 $\mu$ s whenever an accessory insertion, removal or impedance change is detected.

The microphone detection circuit is also an input to the Interrupt control circuit. An interrupt event is triggered whenever an accessory insertion, removal or impedance change is detected. The associated interrupt bit is latched once set; it can be polled at any time or used to control the IRQ signal. See “Interrupts” for more details of the Interrupt event handling.

### FREQUENCY LOCKED LOOP (FLL) LOCK STATUS OUTPUT

The WM1811A maintains a flag indicating the lock status of each of FLLs, which may be used to control other events if required. See “Clocking and Sample Rates” for more details of the FLL.

The FLL Lock signals may be output directly on any GPIO pin by setting the respective GPIO registers as described in “GPIO Control”.

The FLL Lock signals are inputs to the Interrupt control circuit. An interrupt event is triggered on the rising and falling edges of the FLL Lock signals. The associated interrupt bits are latched once set; they can be polled at any time or used to control the IRQ signal. See “Interrupts” for more details of the Interrupt event handling.

### SAMPLE RATE CONVERTER (SRC) LOCK STATUS OUTPUT

The WM1811A maintains a flag indicating the lock status of each of Sample Rate Converters, which may be used to control other events if required. See “Sample Rate Conversion” for more details of the Sample Rate Converters.

The SRC Lock signals may be output directly on any GPIO pin by setting the respective GPIO registers as described in “GPIO Control”.

The SRC Lock signals are inputs to the Interrupt control circuit, after the selectable de-bounce. An interrupt event is triggered on the rising and falling edges of the SRC Lock signals. The associated interrupt bits are latched once set; they can be polled at any time or used to control the IRQ signal. See “Interrupts” for more details of the Interrupt event handling.

### DYNAMIC RANGE CONTROL (DRC) SIGNAL ACTIVITY DETECTION

Signal activity detection is provided on each of the Dynamic Range Controllers (DRCs). These may be configured to indicate when a signal is present on the respective signal path. The signal activity status signals may be used to control other events if required. See “Digital Core Architecture” for more details of the DRCs and the available digital signal paths.

When a DRC is enabled, as described in “Dynamic Range Control (DRC)”, then signal activity detection can be enabled by setting the respective *[DRC]\_SIG\_DET* register bit. The applicable threshold can be defined either as a Peak level (Crest Factor) or an RMS level, depending on the *[DRC]\_SIG\_DET\_MODE* register bit. When Peak level is selected, the threshold is determined by *[DRC]\_SIG\_DET\_PK*, which defines the applicable Crest Factor (Peak to RMS ratio) threshold. If RMS level is selected, then the threshold is set using *[DRC]\_SIG\_DET\_RMS*. These register fields are set independently for each of the three Dynamic Range Controllers, as described in Table 82.

When the DRC is enabled in any of the ADC (digital record) paths, the associated High Pass Filter (HPF) must be enabled also; this ensures that DC offsets are removed prior to the DRC processing. The output path HPF control registers are described in Table 37 (for AIF1 output paths) and Table 45 (for AIF2 output paths). These are described in the “Digital Volume and Filter Control” section.

The DRC Signal Detect signals may be output directly on any GPIO pin by setting the respective GPIO registers as described in “GPIO Control”.

The DRC Signal Detect signals are inputs to the Interrupt control circuit. An interrupt event is triggered on the rising edge of the DRC Signal Detect signals. The associated interrupt bits are latched once set; they can be polled at any time or used to control the IRQ signal. See “Interrupts” for more details of the Interrupt event handling.

REGISTER ADDRESS	BIT	LABEL	DEFAULT	DESCRIPTION
R1088 (0440h) AIF1 DRC1 (1)	15:11	AIF1DRC1_SIG_DET_RMS [4:0]	00000	AIF1 DRC Signal Detect RMS Threshold. This is the RMS signal level for signal detect to be indicated when AIF1DRC1_SIG_DET_MODE=1. 00000 = -30dB 00001 = -31.5dB .... (1.5dB steps) 11110 = -75dB 11111 = -76.5dB
	10:9	AIF1DRC1_SIG_DET_PK [1:0]	00	AIF1 DRC Signal Detect Peak Threshold. This is the Peak/RMS ratio, or Crest Factor, level for signal detect to be indicated when AIF1DRC1_SIG_DET_MODE=0. 00 = 12dB 01 = 18dB 10 = 24dB 11 = 30dB
	7	AIF1DRC1_SIG_DET_MODE	1	AIF1 DRC Signal Detect Mode 0 = Peakthreshold mode 1 = RMSthreshold mode
	6	AIF1DRC1_SIG_DET	0	AIF1 DRC Signal Detect Enable 0 = Disabled 1 = Enabled

REGISTER ADDRESS	BIT	LABEL	DEFAULT	DESCRIPTION
R1344 (0540h) AIF2 DRC (1)	15:11	AIF2DRC_SIG_DET_RMS [4:0]	00000	AIF2 DRC Signal Detect RMS Threshold. This is the RMS signal level for signal detect to be indicated when AIF2DRC_SIG_DET_MODE=1. 00000 = -30dB 00001 = -31.5dB .... (1.5dB steps) 11110 = -75dB 11111 = -76.5dB
	10:9	AIF2DRC_SIG_DET_PK [1:0]	00	AIF2 DRC Signal Detect Peak Threshold. This is the Peak/RMS ratio, or Crest Factor, level for signal detect to be indicated when AIF2DRC_SIG_DET_MODE=0. 00 = 12dB 01 = 18dB 10 = 24dB 11 = 30dB
	7	AIF2DRC_SIG_DET_MODE	1	AIF2 DRC Signal Detect Mode 0 = Peakthreshold mode 1 = RMSthreshold mode
	6	AIF2DRC_SIG_DET	0	AIF2 DRC Signal Detect Enable 0 = Disabled 1 = Enabled

Table 82 DRC Signal Activity Detect GPIO/Interrupt Control

### DIGITAL CORE FIFO ERROR STATUS DETECTION

The WM1811A monitors the Digital Core for error conditions which may occur if a clock rate mismatch is detected. Under these conditions, the digital audio may become corrupted.

The most likely cause of a Digital Core FIFO Error condition is an incorrect system clocking configuration. See "Clocking and Sample Rates" for the WM1811A system clocking requirements.

The Digital Core FIFO Error function is provided in order that the system configuration can be verified during product development.

The FIFO Error signal may be output directly on any GPIO pin by setting the respective GPIO registers as described in "GPIO Control".

The FIFO Error signal is an input to the Interrupt control circuit. An interrupt event is triggered on the rising edge of the FIFO Error signal. The associated interrupt bit is latched once set; it can be polled at any time or used to control the IRQ signal. See "Interrupts" for more details of the Interrupt event handling.

**OPCLK CLOCK OUTPUT**

A clock output (OPCLK) derived from SYSCLK may be output on any GPIO pin by setting the respective GPIO registers as described in "GPIO Control". This clock is enabled by register bit OPCLK\_ENA, and its frequency is controlled by OPCLK\_DIV.

See "Clocking and Sample Rates" for more details of the System Clock (SYSCLK).

REGISTER ADDRESS	BIT	LABEL	DEFAULT	DESCRIPTION
R2 (0002h) Power Management (2)	11	OPCLK_ENA	0	GPIO Clock Output (OPCLK) Enable 0 = Disabled 1 = Enabled
R521 (0209h) Clocking 1	2:0	OPCLK_DIV	000	GPIO Output Clock (OPCLK) Divider 000 = SYSCLK 001 = SYSCLK / 2 010 = SYSCLK / 3 011 = SYSCLK / 4 100 = SYSCLK / 6 101 = SYSCLK / 8 110 = SYSCLK / 12 111 = SYSCLK / 16

**Table 83 OPCLK Control**

**FLL CLOCK OUTPUT**

The FLL Clock outputs may be output directly on any GPIO pin by setting the respective GPIO registers as described in "GPIO Control".

See "Clocking and Sample Rates" for more details of the WM1811A system clocking and for details of how to enable and configure the Frequency Locked Loops.

## INTERRUPTS

The Interrupt Controller has multiple inputs. These include the GPIO input pins, the FLL Lock circuits, SRC Lock circuit, Microphone activity detection, Over-temperature indication and Digital FIFO error detection. Any combination of these inputs can be used to trigger an Interrupt Request (IRQ) event.

There is an Interrupt register field associated with each of the interrupt inputs. These fields are asserted whenever a logic edge is detected on the respective input. Some inputs are triggered on rising edges only; some are triggered on both edges, as noted in Table 84. The Interrupt register fields are held in Registers R1840 and R1841. The Interrupt flags can be polled at any time from these registers, or else in response to the Interrupt Request (IRQ) output being signalled via a GPIO pin.

All of the Interrupts are edge-triggered, as noted above. Many of these are triggered on both the rising and falling edges and, therefore, the Interrupt registers cannot indicate which edge has been detected. The "Raw Status" fields in Register R1842 provide readback of the current value of selected inputs to the Interrupt Controller. Note that the logic levels of any GPIO inputs can be read using the GpN\_LVL registers, as described in Table 79.

Individual mask bits can select or deselect different functions from the Interrupt controller. These are listed within the Interrupt Status Mask registers, as described in Table 84. Note that the Interrupt register fields remain valid, even when masked, but the masked interrupts will not cause the Interrupt Request (IRQ) output to be asserted.

The Interrupt Request (IRQ) output represents the logical 'OR' of all the unmasked interrupts. The Interrupt register fields are latching fields and, once they are set, they are not reset until a '1' is written to the respective register bit(s). The Interrupt Request (IRQ) output is not reset until each of the unmasked interrupts has been reset.

De-bouncing of the GPIO inputs can be enabled using the register bits described in Table 79. De-bouncing is also available on the Temperature Warning and Temperature Shutdown inputs to the Interrupt Controller, in order to avoid false detections - see Table 84 for the associated registers.

The Interrupt Request (IRQ) output can be globally masked by setting the IM\_IRQ register. Under default conditions, the Interrupt Request (IRQ) is not masked.

The Interrupt Request (IRQ) flag may be output on a GPIO pin - see "General Purpose Input/Output".

The WM1811A Interrupt Controller circuit is illustrated in Figure 43. (Note that not all interrupt inputs are shown.) The associated control fields are described in Table 84.

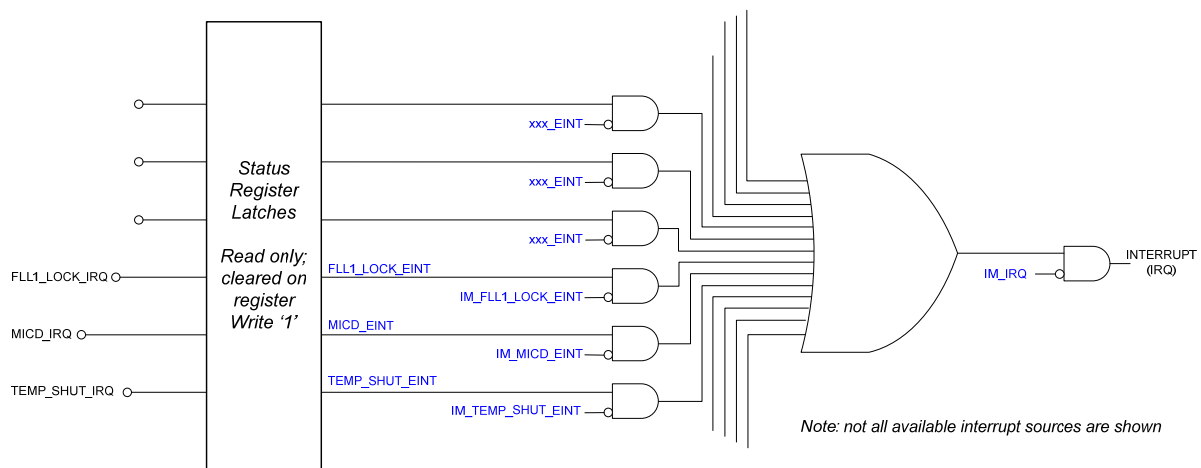

Figure 43 Interrupt Controller

REGISTER ADDRESS	BIT	LABEL	DEFAULT	DESCRIPTION
R1840 (0730h) Interrupt Status 1	10	GP11_EINT	0	GPIO11 Interrupt (Rising and falling edge triggered) Note: Cleared when a '1' is written.
	9	GP10_EINT	0	GPIO10 Interrupt (Rising and falling edge triggered) Note: Cleared when a '1' is written.
	8	GP9_EINT	0	GPIO9 Interrupt (Rising and falling edge triggered) Note: Cleared when a '1' is written.
	7	GP8_EINT	0	GPIO8 Interrupt (Rising and falling edge triggered) Note: Cleared when a '1' is written.
	5	JACKDET_EINT	0	Jack Detect Interrupt (Rising and falling edge triggered) Note: Cleared when a '1' is written.
	0	GP1_EINT	0	GPIO1 Interrupt (Rising and falling edge triggered) Note: Cleared when a '1' is written.
R1841 (0731h) Interrupt Status 2	15	TEMP_WARN_EINT	0	Temperature Warning Interrupt (Rising and falling edge triggered) Note: Cleared when a '1' is written.
	14	DCS_DONE_EINT	0	DC Servo Interrupt (Rising edge triggered) Note: Cleared when a '1' is written.
	12	FIFOS_ERR_EINT	0	Digital Core FIFO Error Interrupt (Rising edge triggered) Note: Cleared when a '1' is written.
	11	AIF2DRC_SIG_DET_INTERRUPT	0	AIF2 DRC Activity Detect Interrupt (Rising edge triggered) Note: Cleared when a '1' is written.
	9	AIF1DRC1_SIG_DET_INTERRUPT	0	AIF1 DRC Activity Detect Interrupt (Rising edge triggered) Note: Cleared when a '1' is written.
	8	SRC2_LOCK_EINT	0	SRC2 Lock Interrupt (Rising and falling edge triggered) Note: Cleared when a '1' is written.
	7	SRC1_LOCK_EINT	0	SRC1 Lock Interrupt (Rising and falling edge triggered) Note: Cleared when a '1' is written.
	6	FLL2_LOCK_EINT	0	FLL2 Lock Interrupt (Rising and falling edge triggered) Note: Cleared when a '1' is written.
	5	FLL1_LOCK_EINT	0	FLL1 Lock Interrupt (Rising and falling edge triggered) Note: Cleared when a '1' is written.
	1	MICD_EINT	0	Microphone Detection Interrupt (Rising edge triggered) Note: Cleared when a '1' is written.
0	TEMP_SHUT_EINT	0	Temperature Shutdown Interrupt (Rising and falling edge triggered) Note: Cleared when a '1' is written.	

REGISTER ADDRESS	BIT	LABEL	DEFAULT	DESCRIPTION
R1842 (0732h) Interrupt Raw Status 2	15	TEMP_WARN_STS	0	Temperature Warning status 0 = Temperature is below warning level 1 = Temperature is above warning level
	14	DCS_DONE_STS	0	DC Servo status 0 = DC Servo not complete 1 = DC Servo complete
	12	FIFOS_ERR_STS	0	Digital Core FIFO Error status 0 = Normal operation 1 = FIFO Error
	11	AIF2DRC_SIG_DETECT_STS	0	AIF2 DRC Signal Detect status 0 = Signal threshold not exceeded 1 = Signal threshold exceeded
	9	AIF1DRC1_SIG_DETECT_STS	0	AIF1 DRC Signal Detect status 0 = Signal threshold not exceeded 1 = Signal threshold exceeded
	8	SRC2_LOCK_STS	0	SRC2 Lock status 0 = Not locked 1 = Locked
	7	SRC1_LOCK_STS	0	SRC1 Lock status 0 = Not locked 1 = Locked
	6	FLL2_LOCK_STS	0	FLL2 Lock status 0 = Not locked 1 = Locked
	5	FLL1_LOCK_STS	0	FLL1 Lock status 0 = Not locked 1 = Locked
	0	TEMP_SHUT_STS	0	Temperature Shutdown status 0 = Temperature is below shutdown level 1 = Temperature is above shutdown level
R1848 (0738h) Interrupt Status 1 Mask	10	IM_GP11_INTERRUPT	1	GPIO11 Interrupt mask. 0 = Do not mask interrupt. 1 = Mask interrupt.
	9	IM_GP10_INTERRUPT	1	GPIO10 Interrupt mask. 0 = Do not mask interrupt. 1 = Mask interrupt.
	8	IM_GP9_INTERRUPT	1	GPIO9 Interrupt mask. 0 = Do not mask interrupt. 1 = Mask interrupt.
	7	IM_GP8_INTERRUPT	1	GPIO8 Interrupt mask. 0 = Do not mask interrupt. 1 = Mask interrupt.
	5	IM_JACKDETECT_INTERRUPT	1	Jack Detect Interrupt mask. 0 = Do not mask interrupt. 1 = Mask interrupt.
	0	IM_GP1_INTERRUPT	1	GPIO1 Interrupt mask. 0 = Do not mask interrupt. 1 = Mask interrupt.

REGISTER ADDRESS	BIT	LABEL	DEFAULT	DESCRIPTION
R1849 (0739h) Interrupt Status 2 Mask	15	IM_TEMP_WARN_EINT	1	Temperature Warning Interrupt mask. 0 = Do not mask interrupt. 1 = Mask interrupt.
	14	IM_DCS_DONE_EINT	1	DC Servo Interrupt mask. 0 = Do not mask interrupt. 1 = Mask interrupt.
	12	IM_FIFOS_ERR_EINT	1	Digital Core FIFO Error Interrupt mask. 0 = Do not mask interrupt. 1 = Mask interrupt.
	11	IM_AIF2DR C_SIG_DET_EINT	1	AIF2 DRC Activity Detect Interrupt mask. 0 = Do not mask interrupt. 1 = Mask interrupt.
	9	IM_AIF1DR C1_SIG_DET_EINT	1	AIF1 DRC Activity Detect Interrupt mask. 0 = Do not mask interrupt. 1 = Mask interrupt.
	8	IM_SRC2_LOCK_EINT	1	SRC2 Lock Interrupt mask. 0 = Do not mask interrupt. 1 = Mask interrupt.
	7	IM_SRC1_LOCK_EINT	1	SRC1 Lock Interrupt mask. 0 = Do not mask interrupt. 1 = Mask interrupt.
	6	IM_FLL2_LOCK_EINT	1	FLL2 Lock Interrupt mask. 0 = Do not mask interrupt. 1 = Mask interrupt.
	5	IM_FLL1_LOCK_EINT	1	FLL1 Lock Interrupt mask. 0 = Do not mask interrupt. 1 = Mask interrupt.
	1	IM_MICD_EINT	1	Microphone Detection Interrupt mask. 0 = Do not mask interrupt. 1 = Mask interrupt.
0	IM_TEMP_SHUT_EINT	1	Temperature Shutdown Interrupt mask. 0 = Do not mask interrupt. 1 = Mask interrupt.	
R1856 (0740h) Interrupt Control	0	IM_IRQ	0	IRQ Output Interrupt mask. 0 = Do not mask interrupt. 1 = Mask interrupt.
R1864 (0748h) IRQ Debounce	5	TEMP_WARN_DB	1	Temperature Warning de-bounce 0 = Disabled 1 = Enabled
	0	TEMP_SHUT_DB	1	Temperature Shutdown de-bounce 0 = Disabled 1 = Enabled

Table 84 Interrupt Configuration



## DIGITAL AUDIO INTERFACE

The WM1811A provides digital audio interfaces for inputting DAC data and outputting ADC or Digital Microphone data. Flexible routing options also allow digital audio to be switched or mixed between interfaces without involving any DAC or ADC.

The WM1811A provides two full audio interfaces, AIF1 and AIF2. A third interface, AIF3, supports Mono PCM digital audio paths to/from the AIF2 DSP functions. AIF3 can also be configured using multiplexers to provide alternate connections to AIF1 or AIF2.

The digital audio interfaces provide flexible connectivity with multiple processors (eg. Applications processor, Baseband processor and Wireless transceiver). A typical configuration is illustrated in Figure 44.

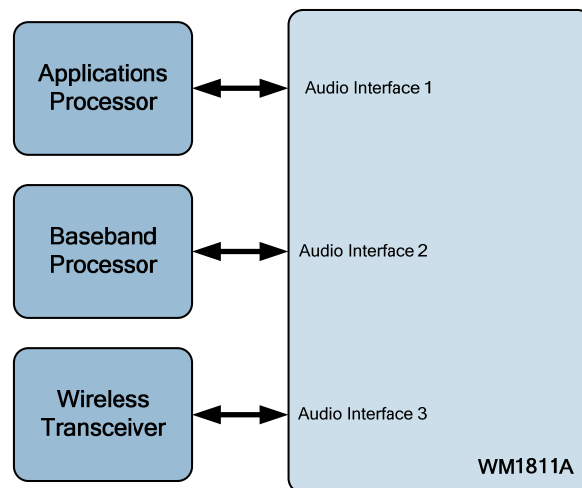

**Figure 44 Typical AIF Connections**

In the general case, the digital audio interface uses four pins:

- ADCDAT: ADC data output
- DACDAT: DAC data input
- LRCLK: Left/Right data alignment clock
- BCLK: Bit clock, for synchronisation

In master interface mode, the clock signals BCLK and LRCLK are outputs from the WM1811A. In slave mode, these signals are inputs, as illustrated below.

As an option (AIF1 only), a GPIO pin can be configured as the Left/Right clock for the ADC. In this case, the LRCLK pin is dedicated to the DAC, allowing the ADC and DAC to be clocked independently.

Four different audio data formats are supported each digital audio interface:

- Left justified
- Right justified
- I<sup>2</sup>S
- DSP mode

All four of these modes are MSB first. They are described in the following sections. Refer to the “Signal Timing Requirements” section for timing information.

Time Division Multiplexing (TDM) is available in all four data format modes. The WM1811A can be configured to transmit and receive in one of two timeslots.

Two variants of DSP mode are supported - ‘Mode A’ and ‘Mode B’. Mono operation can be selected on either audio interface in both DSP modes. PCM operation is supported using the DSP mode.

**MASTER AND SLAVE MODE OPERATION**

The WM1811A digital audio interfaces can operate as a master or slave as shown in Figure 45 and Figure 46. The associated control bits are described in “Digital Audio Interface Control”.

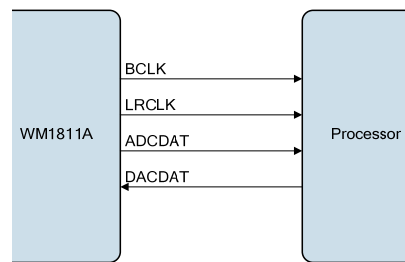

Figure 45 Master Mode

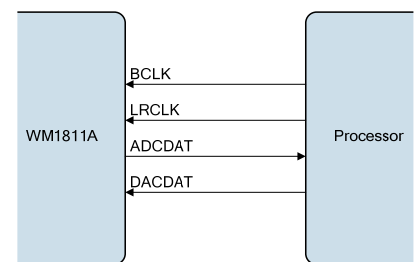

Figure 46 Slave Mode

**OPERATION WITH TDM**

Time division multiplexing (TDM) allows multiple devices to transfer data simultaneously on the same bus. The WM1811A ADCs and DACs support TDM in master and slave modes for all data formats and word lengths. TDM is enabled and configured using register bits defined in the “Digital Audio Interface Control” section.

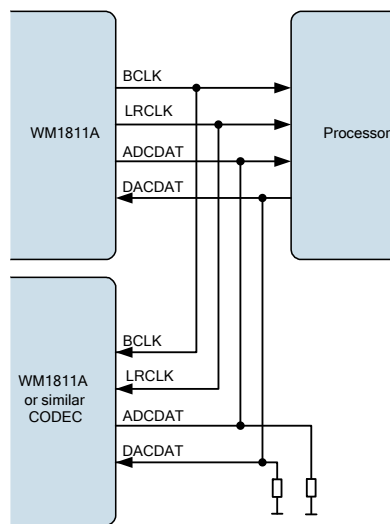

Figure 47 TDM with WM1811A as Master

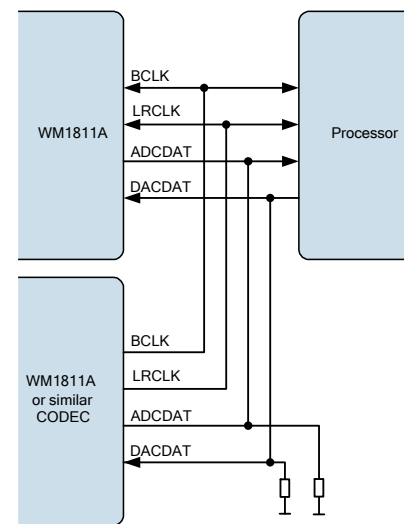

Figure 48 TDM with Other CODEC as Master

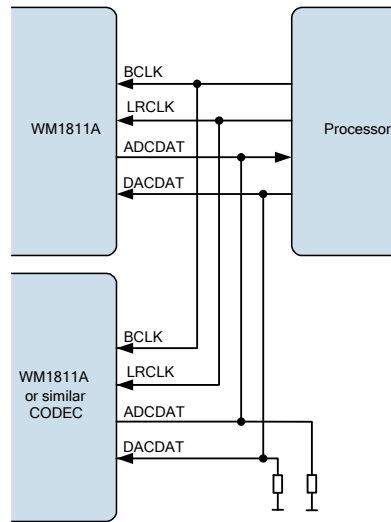

Figure 49 TDM with Processor as Master

**Note:** The WM1811A is a 24-bit device. If the user operates the WM1811A in 32-bit mode then the 8 LSBs will be ignored on the receiving side and not driven on the transmitting side. It is therefore recommended to add a pull-down resistor if necessary to the DACDAT line and the ADCDAT line in TDM mode.

**AUDIO DATA FORMATS (NORMAL MODE)**

The audio data modes supported by the WM1811A are described below. Note that the polarity of the BCLK and LRCLK signals can be inverted if required; the following descriptions all assume the default, non-inverted polarity of these signals.

In Right Justified mode, the LSB is available on the last rising edge of BCLK before a LRCLK transition. All other bits are transmitted before (MSB first). Depending on word length, BCLK frequency and sample rate, there may be unused BCLK cycles after each LRCLK transition.

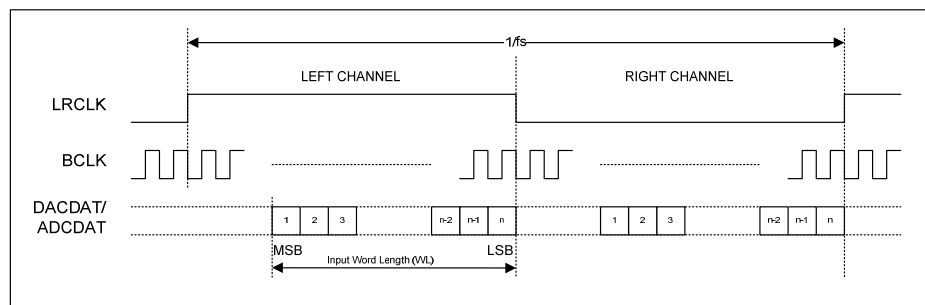

Figure 50 Right Justified Audio Interface (assuming n-bit word length)

In Left Justified mode, the MSB is available on the first rising edge of BCLK following a LRCLK transition. The other bits up to the LSB are then transmitted in order. Depending on word length, BCLK frequency and sample rate, there may be unused BCLK cycles before each LRCLK transition.

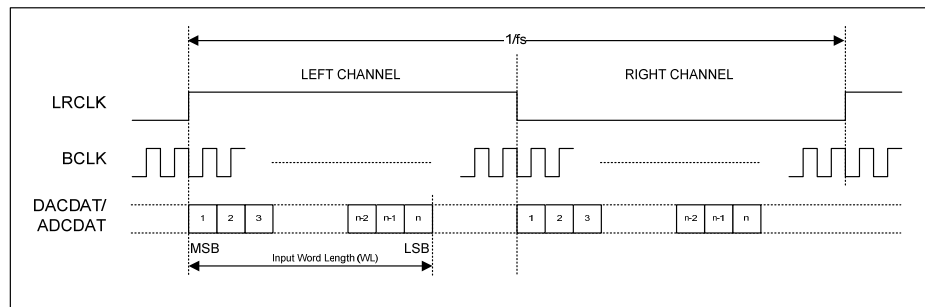

Figure 51 Left Justified Audio Interface (assuming n-bit word length)

In I<sup>2</sup>S mode, the MSB is available on the second rising edge of BCLK following a LRCLK transition. The other bits up to the LSB are then transmitted in order. Depending on word length, BCLK frequency and sample rate, there may be unused BCLK cycles between the LSB of one sample and the MSB of the next.

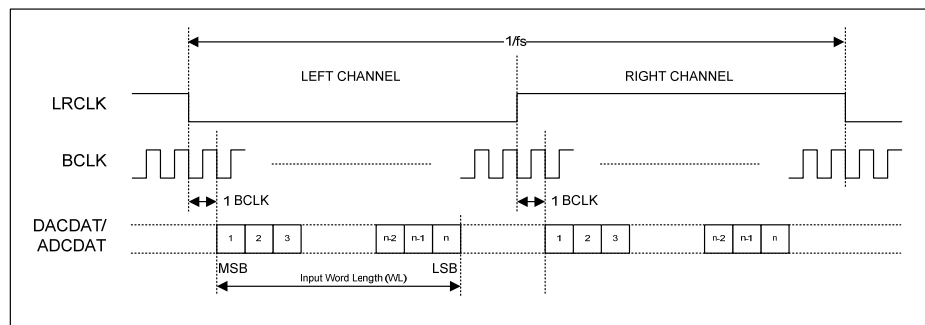

Figure 52 I2S Justified Audio Interface (assuming n-bit word length)

In DSP mode, the left channel MSB is available on either the 1<sup>st</sup> (mode B) or 2<sup>nd</sup> (mode A) rising edge of BCLK following a rising edge of LRCLK. Right channel data immediately follows left channel data. Depending on word length, BCLK frequency and sample rate, there may be unused BCLK cycles between the LSB of the right channel data and the next sample.

The selected mode (Mode A or Mode B) is determined by the AIFnDAC\_LRCLK\_INV bits for the AIFn digital input (playback) signal paths, and by the AIFnADC\_LRCLK\_INV bits for the AIFn digital output (record) signal paths.

Note that the DSP Mode is selected independently for the input/output paths of each digital audio interface.

In device master mode, the LRCLKout will resemble the frame pulse shown in Figure 53 and Figure 54. In device slave mode, Figure 55 and Figure 56, it is possible to use any length of frame pulse less than 1/fs, providing the falling edge of the frame pulse occurs greater than one BCLK period before the rising edge of the next frame pulse.

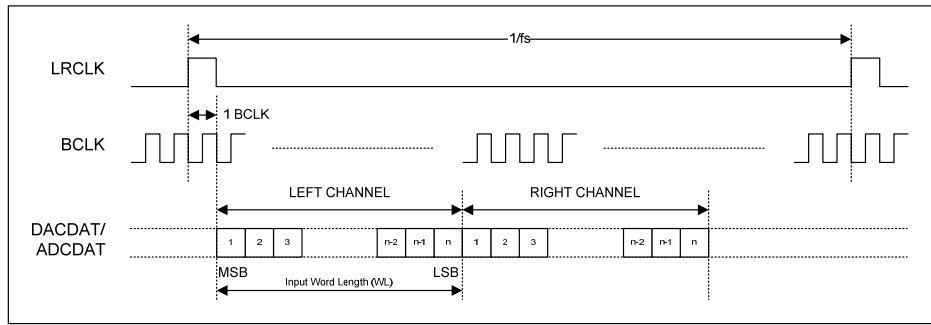

Figure 53 DSP Mode A (AIFnDAC\_LRCLK\_INV / AIFnADC\_LRCLK\_INV=0, Master)

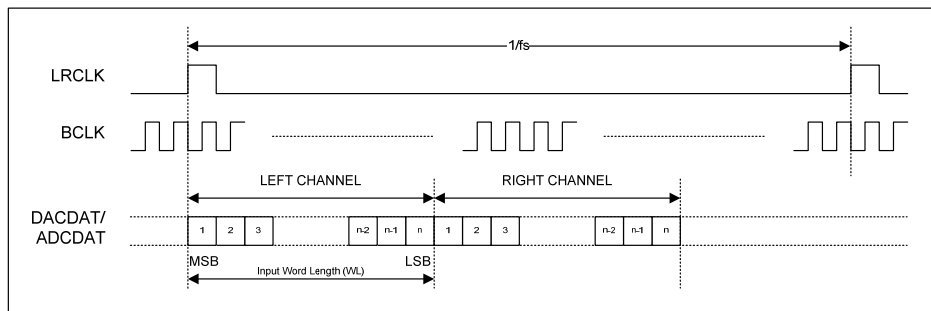

Figure 54 DSP B Mode (AIFnDAC\_LRCLK\_INV / AIFnADC\_LRCLK\_INV=1, Master)

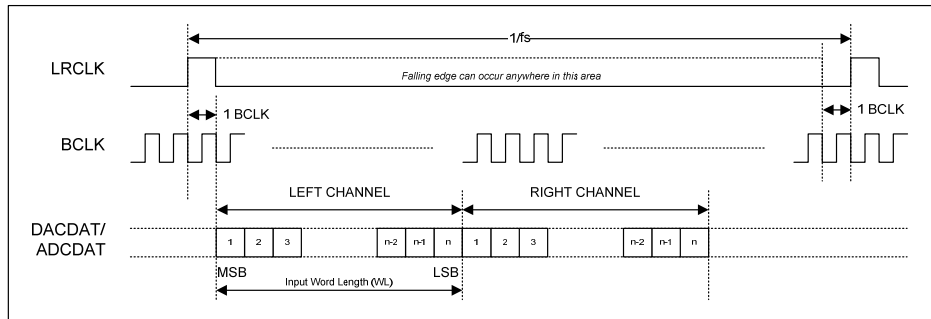

Figure 55 DSP Mode A (AIFnDAC\_LRCLK\_INV / AIFnADC\_LRCLK\_INV=0, Slave)

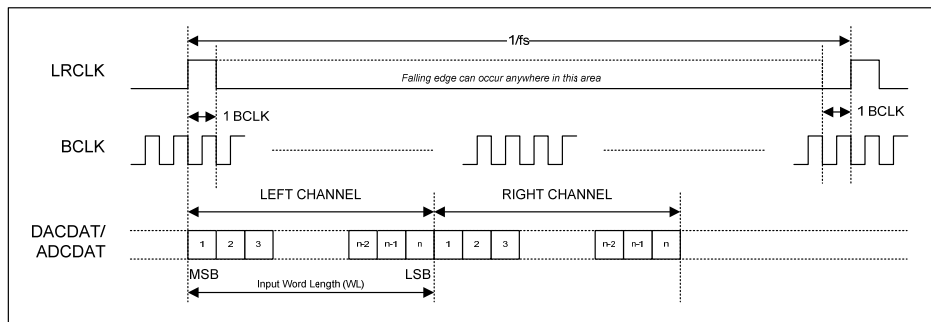

Figure 56 DSP Mode B (AIFnDAC\_LRCLK\_INV / AIFnADC\_LRCLK\_INV=1, Slave)

Mono mode operation is available in DSP interface mode. When Mono mode is enabled, the audio data is transmitted or received starting on either the 1<sup>st</sup> (mode B) or 2<sup>nd</sup> (mode A) rising edge of BCLK following a rising edge of LRCLK.

PCM operation is supported in DSP interface mode. WM1811A ADC data that is output on the Left Channel will be read as mono PCM data by the receiving equipment. Mono PCM data received by the WM1811A will be treated as Left Channel data. This data may be routed to the Left/Right DACs using the control fields described in the “Digital Mixing” and “Digital Audio Interface Control” sections.

### AUDIO DATA FORMATS (TDM MODE)

TDM is supported in master and slave modes. All audio interface data formats support time division multiplexing (TDM) for ADC and DAC data.

On AIF1, the TDM format is enabled by register control (AIF1ADC\_TDM and AIF1DAC\_TDM for the output and input paths respectively). When TDM is enabled on AIF1, the data formats shown in Figure 57 to Figure 61 are always selected, and the WM1811A transmits or receives AIF1 data in one of the two available timeslots; the ADCDAT1 output is tri-stated when not outputting data.

Two AIF1 time slots are available (Slot 0 and Slot 1), selected by register bits AIF1ADC\_TDM\_CHAN and AIF1DAC\_TDM\_CHAN; these determine the active time slot for the ADC data and the DAC data respectively.

On AIF2, the TDM format is enabled by register control (AIF2ADC\_TDM and AIF2DAC\_TDM for the output and input paths respectively). When TDM is enabled on AIF2, the data formats shown in Figure 57 to Figure 61 are always selected, and the WM1811A transmits or receives AIF2 data in one of the two available timeslots; the ADCDAT2 output is tri-stated when not outputting data.

Two AIF2 time slots are available (Slot 0 and Slot 1), selected by register bits AIF2ADC\_TDM\_CHAN and AIF2DAC\_TDM\_CHAN; these determine the active time slot for the ADC data and the DAC data respectively.

When TDM is enabled, the ADCDAT pin will be tri-stated immediately before and immediately after data transmission, to allow another ADC device to drive this signal line for the remainder of the sample period. Note that it is important that two ADC devices do not attempt to drive the data pin simultaneously. A short circuit may occur if the transmission time of the two ADC devices overlap with each other. See “Audio Interface Timing” for details of the ADCDAT output relative to BCLK signal. Note that it is possible to ensure a gap exists between transmissions by setting the transmitted word length to a value higher than the actual length of the data. For example, if 32-bit word length is selected where only 24-bit data is available, then the WM1811A interface will tri-state after transmission of the 24-bit data, ensuring a gap after the WM1811A TDM slot.

When TDM is enabled, the BCLK frequency must be high enough to allow data from both time slots to be transferred. The relative timing of Slot 0 and Slot 1 depends upon the selected data format, as shown in Figure 57 to Figure 61.

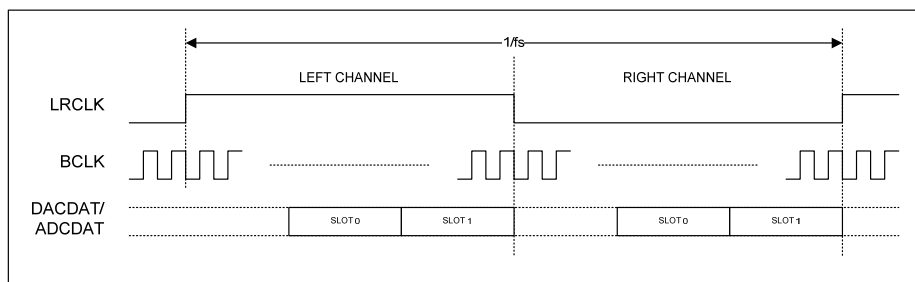

Figure 57 TDM in Right-Justified Mode

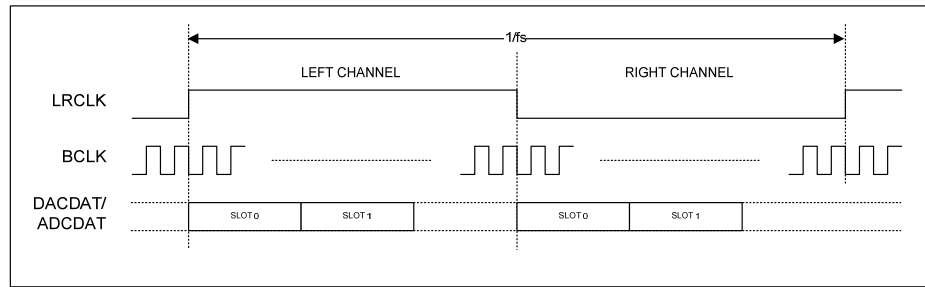

Figure 58 TDM in Left-Justified Mode

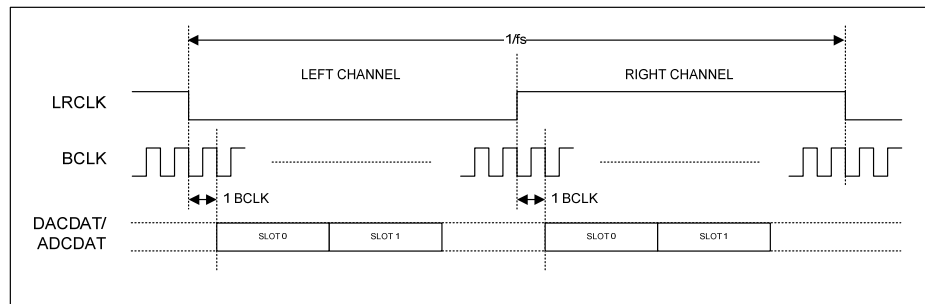

Figure 59 TDM in I²S Mode

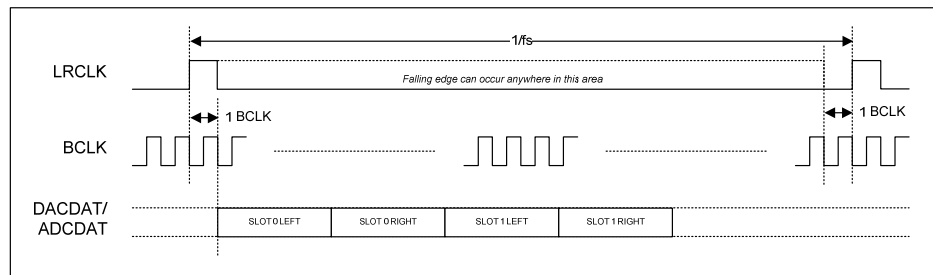

Figure 60 TDM in DSP Mode A

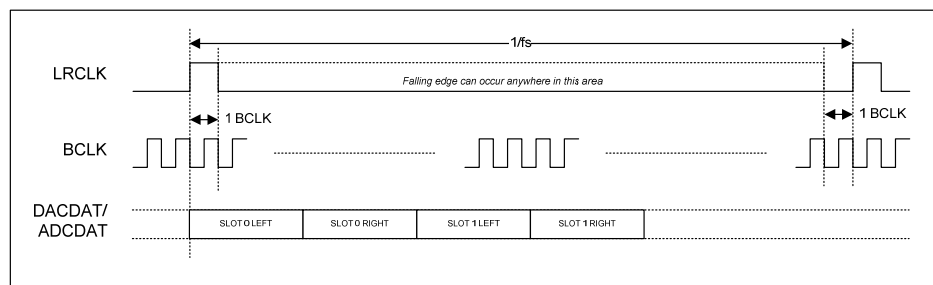

Figure 61 TDM in DSP Mode B

## DIGITAL AUDIO INTERFACE CONTROL

This section describes the configuration of the WM1811A digital audio interface paths.

Interfaces AIF1 and AIF2 can be configured as Master or Slave, or can be tri-stated. Each input and output signal path can be independently enabled or disabled. AIF output (digital record) and AIF input (digital playback) paths can use a common Left/Right clock, or can use separate clocks for mixed sample rates.

Interfaces AIF1 and AIF2 each support flexible formats, word-length, TDM configuration, channel swapping and input path digital boost functions. 8-bit companding modes and digital loopback is also possible.

A third interface, AIF3, supports Mono PCM digital audio paths to/from the AIF2 DSP functions. AIF3 can also be configured using multiplexers to provide alternate connections to AIF1 or AIF2. Note that AIF3 operates in Master mode only.

### AIF1 - MASTER / SLAVE AND TRI-STATE CONTROL

The Digital Audio Interface AIF1 can operate in Master or Slave modes, selected by AIF1\_MSTR. In Master mode, the BCLK1 and LRCLK1 signals are generated by the WM1811A when one or more AIF1 channels is enabled.

When AIF1\_LRCLK\_FRC or AIF1\_CLK\_FRC is set in Master mode, then LRCLK1 and ADCLRCLK1 are output at all times, including when none of the AIF1 audio channels is enabled. Note that LRCLK1 and ADCLRCLK1 are derived from BCLK1, and either an internal or external BCLK1 signal must also be present to generate LRCLK1 or ADCLRCLK1.

When AIF1\_CLK\_FRC is set in Master mode, then BCLK1 is output at all times, including when none of the AIF1 audio channels is enabled.

The AIF1 interface can be tri-stated by setting the AIF1\_TRI register. When this bit is set, then all of the AIF1 outputs are un-driven (high-impedance). Note that the ADCLRCLK1/GPIO1 pin is a configurable pin which may take different functions independent of AIF1. The AIF1\_TRI register only controls the ADCLRCLK1/GPIO1 pin when its function is set to ADCLRCLK1. See "General Purpose Input/Output" to configure the GPIO1 pin.

REGISTER ADDRESS	BIT	LABEL	DEFAULT	DESCRIPTION
R770 (0302h) AIF1 Master/Slave	15	AIF1_TRI	0	AIF1 Audio Interface tri-state 0 = AIF1 pins operate normally 1 = Tri-state all AIF1 interface pins Note that the GPIO1 pin is controlled by this register only when configured as ADCLRCLK1.
	14	AIF1_MSTR	0	AIF1 Audio Interface Master Mode Select 0 = Slave mode 1 = Master mode
	13	AIF1_CLK_FRC	0	Forces BCLK1, LRCLK1 and ADCLRCLK1 to be enabled when all AIF1 audio channels are disabled. 0 = Normal 1 = BCLK1, LRCLK1 and ADCLRCLK1 always enabled in Master mode
	12	AIF1_LRCLK_FRC	0	Forces LRCLK1 and ADCLRCLK1 to be enabled when all AIF1 audio channels are disabled. 0 = Normal 1 = LRCLK1 and ADCLRCLK1 always enabled in Master mode

Table 85 AIF1 Master / Slave and Tri-state Control



**AIF1 - SIGNAL PATH ENABLE**

The AIF1 interface supports two input channels and two output channels. Each of the available channels can be enabled or disabled using the register bits defined in Table 86. These register controls are illustrated in Figure 66.

REGISTER ADDRESS	BIT	LABEL	DEFAULT	DESCRIPTION
R4 (0004h) Power Management (4)	9	AIF1ADC1L_ENA	0	Enable AIF1ADC (Left) output path 0 = Disabled 1 = Enabled
	8	AIF1ADC1R_ENA	0	Enable AIF1ADC (Right) output path 0 = Disabled 1 = Enabled
R5 (0005h) Power Management (5)	9	AIF1DAC1L_ENA	0	Enable AIF1DAC (Left) input path 0 = Disabled 1 = Enabled
	8	AIF1DAC1R_ENA	0	Enable AIF1DAC (Right) input path 0 = Disabled 1 = Enabled

**Table 86 AIF1 Signal Path Enable****AIF1 - BCLK AND LRCLK CONTROL**

The BCLK1 frequency is controlled relative to AIF1CLK by the AIF1\_BCLK\_DIV divider. See "Clocking and Sample Rates" for details of the AIF1 clock, AIF1CLK.

The LRCLK1 frequency is controlled relative to BCLK1 by the AIF1DAC\_RATE divider.

In Master mode, the LRCLK1 output is generated by the WM1811A when any of the AIF1 channels is enabled. (Note that, when GPIO1 is configured as ADCLRCLK1, then only the AIF1 DAC channels will cause LRCLK1 to be output.)

In Slave mode, the LRCLK1 output is disabled by default to allow another digital audio interface to drive this pin. It is also possible to force the LRCLK1 signal to be output, using the AIF1DAC\_LRCLK\_DIR or AIF1ADC\_LRCLK\_DIR register bits, allowing mixed master and slave modes. (Note that, when GPIO1 is configured as ADCLRCLK1, then only the AIF1DAC\_LRCLK\_DIR bit will force the LRCLK1 signal.)

When the GPIO1 pin is configured as ADCLRCLK1, then the ADCLRCLK1 frequency is controlled relative to BCLK1 by the AIF1ADC\_RATE divider. In this case, the ADCLRCLK1 is dedicated to AIF1 output, and the LRCLK1 pin is dedicated to AIF1 input, allowing different sample rates to be supported in the two paths.

In Master mode, with GPIO1 pin configured as ADCLRCLK1, this output is enabled when any of the AIF1 ADC channels is enabled. The ADCLRCLK1 signal can also be enabled in Slave mode, using the AIF1ADC\_LRCLK\_DIR bit, allowing mixed master and slave modes.

When the GPIO1 pin is not configured as ADCLRCLK1, then the LRCLK1 signal applies to the ADC and DAC channels, at a rate set by AIF1DAC\_RATE.

See "General Purpose Input/Output" for the configuration of GPIO1. Note that, in Ultrasonic (4FS) mode, the GPIO1 pin must be configured as ADCLRCLK1.

The BCLK1 output can be inverted using the AIF1\_BCLK\_INV register bit. The LRCLK1 and ADCLRCLK1 output (when selected) can be inverted using the AIF1DAC\_LRCLK\_INV and AIF1ADC\_LRCLK\_INV register controls respectively.

Note that in Slave mode, when BCLK1 is an input, the AIF1\_BCLK\_INV register selects the polarity of the received BCLK1 signal. Under default conditions, DACDAT1 input is captured on the rising edge of BCLK1, as illustrated in Figure 4. When AIF1\_BCLK\_INV = 1, DACDAT1 input is captured on the falling edge of BCLK1.

The AIF1 clock generators are controlled as illustrated in Figure 62.

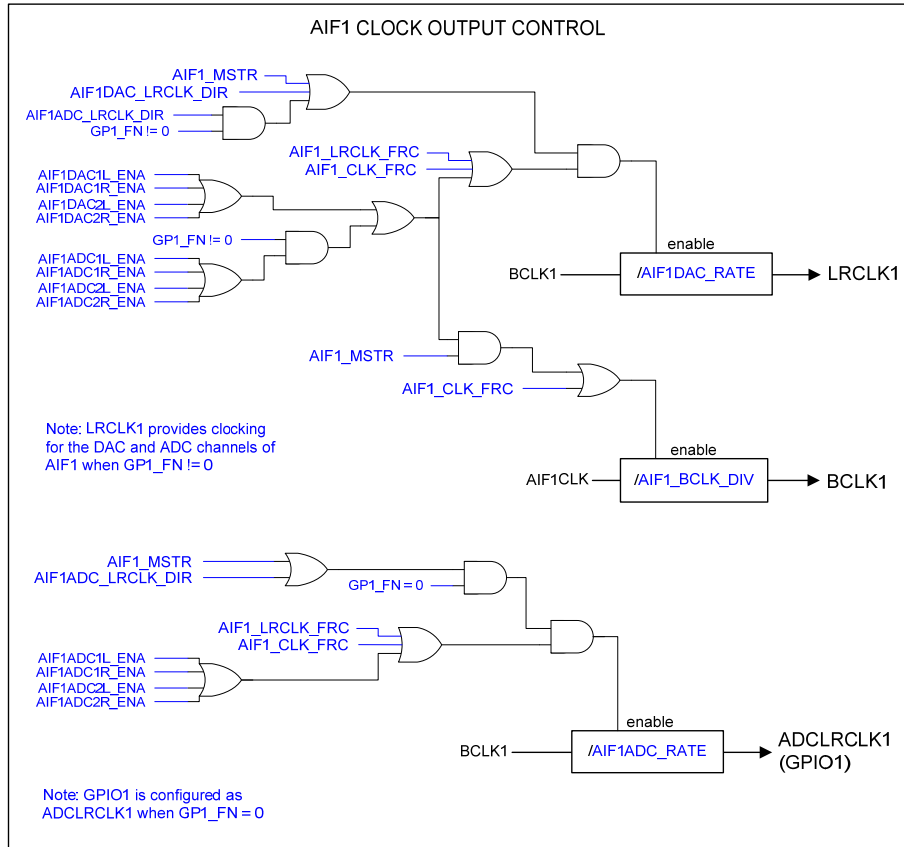

Figure 62 Audio Interface 1 - BCLK and LRCLK Control

REGISTER ADDRESS	BIT	LABEL	DEFAULT	DESCRIPTION
R768 (0300h) AIF1 Control (1)	8	AIF1_BCLK _INV	0	BCLK1 Invert 0 = BCLK1 not inverted 1 = BCLK1 inverted Note that AIF1_BCLK_INV selects the BCLK1 polarity in Master mode and in Slave mode.
R771 (0303h) AIF1 BCLK	8:4	AIF1_BCLK _DIV [4:0]	00100	BCLK1 Rate 00000 = AIF1CLK 00001 = AIF1CLK / 1.5 00010 = AIF1CLK / 2 00011 = AIF1CLK / 3 00100 = AIF1CLK / 4 00101 = AIF1CLK / 5 00110 = AIF1CLK / 6 00111 = AIF1CLK / 8 01000 = AIF1CLK / 11 01001 = AIF1CLK / 12 01010 = AIF1CLK / 16 01011 = AIF1CLK / 22 01100 = AIF1CLK / 24 01101 = AIF1CLK / 32 01110 = AIF1CLK / 44 01111 = AIF1CLK / 48 10000 = AIF1CLK / 64 10001 = AIF1CLK / 88 10010 = AIF1CLK / 96 10011 = AIF1CLK / 128 10100 = AIF1CLK / 176 10101 = AIF1CLK / 192 10110 - 11111 = Reserved
R772 (0304h) AIF1ADC LRCLK	12	AIF1ADC_L RCLK_INV	0	Right, left and I <sup>2</sup> S modes – ADCLRCLK1 polarity 0 = normal ADCLRCLK1 polarity 1 = invert ADCLRCLK1 polarity Note that AIF1ADC_LRCLK_INV selects the ADCLRCLK1 polarity in Master mode and in Slave mode.  DSP Mode – mode A/B select 0 = MSB is available on 2nd BCLK1 rising edge after ADCLRCLK1 rising edge (mode A) 1 = MSB is available on 1st BCLK1 rising edge after ADCLRCLK1 rising edge (mode B)
	11	AIF1ADC_L RCLK_DIR	0	Allows ADCLRCLK1 to be enabled in Slave mode 0 = Normal 1 = ADCLRCLK1 enabled in Slave mode
	10:0	AIF1ADC_R ATE [10:0]	040h	ADCLRCLK1 Rate ADCLRCLK1 clock output = BCLK1 / AIF1ADC_RATE  Integer (LSB = 1) Valid from 8..2047

REGISTER ADDRESS	BIT	LABEL	DEFAULT	DESCRIPTION
R773 (0305h) AIF1DAC LRCLK	12	AIF1DAC_L RCLK_INV	0	Right, left and I <sup>2</sup> S modes – LRCLK1 polarity 0 = normal LRCLK1 polarity 1 = invert LRCLK1 polarity Note that AIF1DAC_LRCLK_INV selects the LRCLK1 polarity in Master mode and in Slave mode.  DSP Mode – mode A/B select 0 = MSB is available on 2nd BCLK1 rising edge after LRCLK1 rising edge (mode A) 1 = MSB is available on 1st BCLK1 rising edge after LRCLK1 rising edge (mode B)
	11	AIF1DAC_L RCLK_DIR	0	Allows LRCLK1 to be enabled in Slave mode 0 = Normal 1 = LRCLK1 enabled in Slave mode
	10:0	AIF1DAC_R ATE [10:0]	040h	LRCLK1 Rate LRCLK1 clock output = BCLK1 / AIF1DAC_RATE  Integer (LSB = 1) Valid from 8..2047

Table 87 AIF1 BCLK and LRCLK Control

### AIF1 - DIGITAL AUDIO DATA CONTROL

The register bits controlling the audio data format, word length, left/right channel selection and TDM control for AIF1 are described in Table 88.

When TDM mode is enabled on AIF1, the WM1811A can transmit and receive audio data in Slot 0 or Slot 1. In this case, the ADCDAT1 output is tri-stated during the unused timeslot, allowing another device to transmit data on the same pin. See "Signal Timing Requirements" for the associated timing details. (Note that, when TDM is not enabled on AIF1, the ADCDAT1 output is driven logic '0' during the unused timeslot.)

In DSP mode, the left channel MSB is available on either the 1<sup>st</sup> (mode B) or 2<sup>nd</sup> (mode A) rising edge of BCLK following a rising edge of LRCLK (assuming default BCLK polarity).

When the AIF1DAC\_LRCLK\_INV bit is set in DSP mode, then DSP Mode B is selected for the AIF1 digital input (playback) signal path. When the AIF1DAC\_LRCLK\_INV bit is not set, then DSP Mode A is selected.

When the AIF1ADC\_LRCLK\_INV bit is set in DSP mode, then DSP Mode B is selected for the AIF1 digital output (record) signal path. When the AIF1ADC\_LRCLK\_INV bit is not set, then DSP Mode A is selected.

Note that the DSP Mode is selected independently for the input/output paths of each digital audio interface. Also note that the AIF1ADCLRCLK\_INV bits remain valid even when the LRCLK signal is common for both paths. See Table 87 for details of the AIF1DAC\_LRCLK\_INV and AIF1ADC\_LRCLK\_INV register fields.

A digital gain function is available at the audio interface input path to boost the DAC volume when a small signal is received on DACDAT1. This is controlled using the AIF1DAC\_BOOST register. To prevent clipping, this function should not be used when the boosted data is expected to be greater than 0dBFS.

REGISTER ADDRESS	BIT	LABEL	DEFAULT	DESCRIPTION
R768 (0300h) AIF1 Control (1)	15	AIF1ADCL_ SRC	0	AIF1 Left Digital Audio interface source 0 = Left ADC data is output on left channel 1 = Right ADC data is output on left channel

REGISTER ADDRESS	BIT	LABEL	DEFAULT	DESCRIPTION
	14	AIF1ADCR_SRC	1	AIF1 Right Digital Audio interface source 0 = Left ADC data is output on right channel 1 = Right ADC data is output on right channel
	13	AIF1ADC_TDM	0	AIF1 transmit (ADC) TDM Enable 0 = Normal ADCDAT1 operation 1 = TDM enabled on ADCDAT1
	12	AIF1ADC_TDM_CHAN	0	AIF1 transmit (ADC) TDM Slot Select 0 = Slot 0 1 = Slot 1
	6:5	AIF1_WL [1:0]	10	AIF1 Digital Audio Interface Word Length 00 = 16 bits 01 = 20 bits 10 = 24 bits 11 = 32 bits Note - 8-bit modes can be selected using the "Companding" control bits.
	4:3	AIF1_FMT [1:0]	10	AIF1 Digital Audio Interface Format 00 = Right justified 01 = Left justified 10 = I <sup>2</sup> S Format 11 = DSP Mode
R769 (0301h) AIF1 Control (2)	15	AIF1DACL_SRC	0	AIF1 Left Receive Data Source Select 0 = Left DAC receives left interface data 1 = Left DAC receives right interface data
	14	AIF1DACR_SRC	1	AIF1 Right Receive Data Source Select 0 = Right DAC receives left interface data 1 = Right DAC receives right interface data
	13	AIF1DAC_TDM	0	AIF1 receive (DAC) TDM Enable 0 = Normal DACDAT1 operation 1 = TDM enabled on DACDAT1
	12	AIF1DAC_TDM_CHAN	0	AIF1 receive(DAC) TDM Slot Select 0 = Slot 0 1 = Slot 1
	11:10	AIF1DAC_BOOST [1:0]	00	AIF1 Input Path Boost 00 = 0dB 01 = +6dB (input must not exceed -6dBFS) 10 = +12dB (input must not exceed -12dBFS) 11 = +18dB (input must not exceed -18dBFS)
R774 (0306h) AIF1 DAC Data	1	AIF1DACL_DAT_INV	0	AIF1 Left Receive Data Invert 0 = Not inverted 1 = Inverted
	0	AIF1DACR_DAT_INV	0	AIF1 Right Receive Data Invert 0 = Not inverted 1 = Inverted
R775 (0307h) AIF1 ADC Data	1	AIF1ADCL_DAT_INV	0	AIF1 Left Transmit Data Invert 0 = Not inverted 1 = Inverted
	0	AIF1ADCR_DAT_INV	0	AIF1 Right Transmit Data Invert 0 = Not inverted 1 = Inverted

Table 88 AIF1 Digital Audio Data Control

**AIF1 - MONO MODE**

AIF1 can be configured to operate in mono DSP mode by setting AIF1\_MONO = 1 as described in Table 89. Note that mono mode is only supported in DSP mode, ie when AIF1\_FMT = 11.

In mono mode, the Left channel data or the Right channel data may be selected for output on ADCDAT1. The selected channel is determined by the AIF1ADC1L\_ENA and AIF1ADC1R\_ENA bits. (If both bits are set, then the Right channel data is selected.)

In mono mode, the DACDAT1 input can be enabled on the Left and/or Right signal paths using the AIF1DAC1L\_ENA and AIF1DAC1R\_ENA bits. The mono input can be enabled on both paths at the same time if required.

REGISTER ADDRESS	BIT	LABEL	DEFAULT	DESCRIPTION
R769 (0301h) AIF1 Control (2)	8	AIF1_MONO	0	AIF1 DSP Mono Mode 0 = Disabled 1 = Enabled Note that Mono Mode is only supported when AIF1_FMT = 11.

**Table 89 AIF1 Mono Mode Control****AIF1 - COMPANDING**

The WM1811A supports A-law and  $\mu$ -law companding on both transmit (ADC) and receive (DAC) sides of AIF1. This is configured using the register bits described in Table 90.

REGISTER ADDRESS	BIT	LABEL	DEFAULT	DESCRIPTION
R769 (0301h) AIF1 Control (2)	4	AIF1DAC_C OMP	0	AIF1 Receive Companding Enable 0 = Disabled 1 = Enabled
	3	AIF1DAC_C OMPMODE	0	AIF1 Receive Companding Type 0 = $\mu$ -law 1 = A-law
	2	AIF1ADC_C OMP	0	AIF1 Transmit Companding Enable 0 = Disabled 1 = Enabled
	1	AIF1ADC_C OMPMODE	0	AIF1 Transmit Companding Type 0 = $\mu$ -law 1 = A-law

**Table 90 AIF1 Companding**

Companding involves using a piecewise linear approximation of the following equations (as set out by ITU-T G.711 standard) for data compression:

$\mu$ -law (where  $\mu=255$  for the U.S. and Japan):

$$F(x) = \ln(1 + \mu|x|) / \ln(1 + \mu) \quad \text{for } -1 \leq x \leq 1$$

A-law (where  $A=87.6$  for Europe):

$$F(x) = A|x| / (1 + \ln A) \quad \text{for } x \leq 1/A$$

$$F(x) = (1 + \ln A|x|) / (1 + \ln A) \quad \text{for } 1/A \leq x \leq 1$$

The companded data is also inverted as recommended by the G.711 standard (all 8 bits are inverted for  $\mu$ -law, all even data bits are inverted for A-law). The data will be transmitted as the first 8 MSBs of data.

Companding converts 13 bits ( $\mu$ -law) or 12 bits (A-law) to 8 bits using non-linear quantization. This provides greater precision for low amplitude signals than for high amplitude signals, resulting in a greater usable dynamic range than 8 bit linear quantization. The companded signal is an 8-bit word comprising sign (1 bit), exponent (3 bits) and mantissa (4 bits).

AIF1 8-bit mode is selected whenever AIF1DAC\_COMP=1 or AIF1ADC\_COMP=1. The use of 8-bit data allows samples to be passed using as few as 8 BCLK1 cycles per LRCLK1 frame. When using DSP mode B, 8-bit data words may be transferred consecutively every 8 BCLK1 cycles.

AIF1 8-bit mode (without Companding) may be enabled by setting AIF1DAC\_COMPMODE=1 or AIF1ADC\_COMPMODE=1, when AIF1DAC\_COMP=0 and AIF1ADC\_COMP=0.

BIT7	BIT[6:4]	BIT[3:0]
SIGN	EXPONENT	MANTISSA

Table 91 8-bit Companded Word Composition

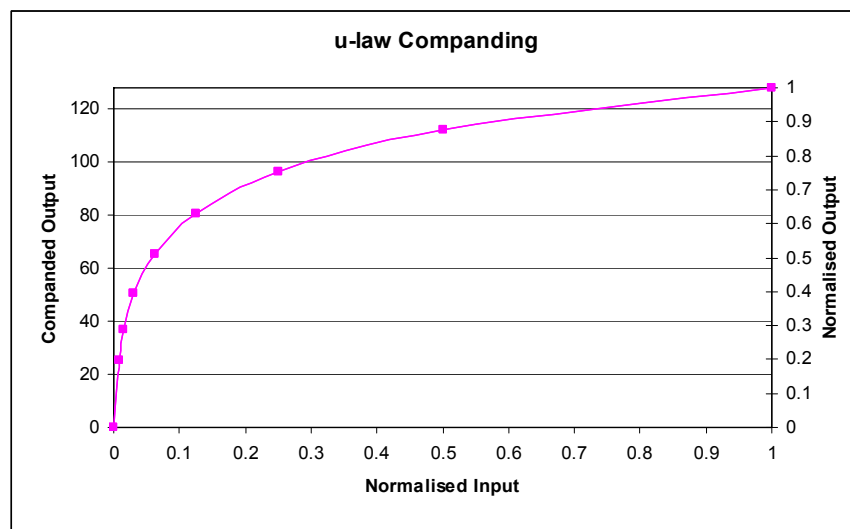

Figure 63  $\mu$ -Law Companding

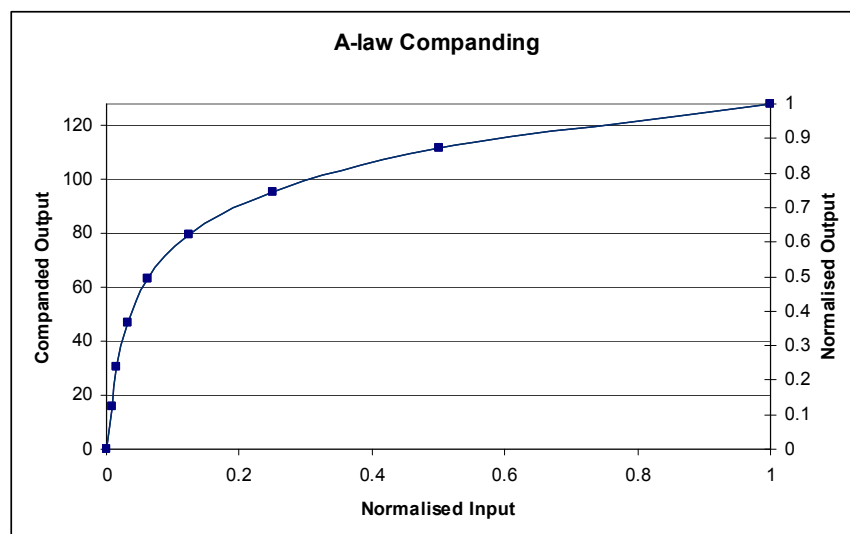

Figure 64 A-Law Companding

**AIF1 - LOOPBACK**

The AIF1 interface can provide a Loopback option. When the AIF1\_LOOPBACK bit is set, then AIF1 digital audio output is routed to the AIF1 digital audio input. The normal input (DACDAT1) is not used when AIF1 Loopback is enabled.

REGISTER ADDRESS	BIT	LABEL	DEFAULT	DESCRIPTION
R769 (0301h) AIF1 Control (2)	0	AIF1_LOOPBACK	0	AIF1 Digital Loopback Function 0 = No loopback 1 = Loopback enabled (ADCDAT1 data output is directly input to DACDAT1 data input).

**Table 92 AIF1 Loopback****AIF1 - DIGITAL PULL-UP AND PULL-DOWN**

The WM1811A provides integrated pull-up and pull-down resistors on each of the DACDAT1, LRCLK1 and BCLK1 pins. This provides a flexible capability for interfacing with other devices.

Each of the pull-up and pull-down resistors can be configured independently using the register bits described in Table 93. Note that if the Pull-up and Pull-down are both enabled for any pin, then the pull-up and pull-down will be disabled.

REGISTER ADDRESS	BIT	LABEL	DEFAULT	DESCRIPTION
R1824 (0720h) Pull Control (1)	5	DACDAT1_PU	0	DACDAT1 Pull-up enable 0 = Disabled 1 = Enabled
	4	DACDAT1_PD	0	DACDAT1 Pull-down enable 0 = Disabled 1 = Enabled
	3	DACLCLK1_PU	0	LRCLK1 Pull-up enable 0 = Disabled 1 = Enabled
	2	DACLCLK1_PD	0	LRCLK1 Pull-down enable 0 = Disabled 1 = Enabled
	1	BCLK1_PU	0	BCLK1 Pull-up enable 0 = Disabled 1 = Enabled
	0	BCLK1_PD	0	BCLK1 Pull-down enable 0 = Disabled 1 = Enabled

**Table 93 AIF1 Digital Pull-Up and Pull-Down Control****AIF2 - MASTER / SLAVE AND TRI-STATE CONTROL**

The Digital Audio Interface AIF2 can operate in Master or Slave modes, selected by AIF2\_MSTR. In Master mode, the BCLK2 and LRCLK2 signals are generated by the WM1811A when one or more AIF2 channels is enabled.

When AIF2\_LRCLK\_FRC or AIF2\_CLK\_FRC is set in Master mode, then LRCLK2 is output at all times, including when none of the AIF2 audio channels is enabled. Note that LRCLK2 is derived from BCLK2, and either an internal or external BCLK2 signal must be present to generate LRCLK2.

When AIF2\_CLK\_FRC is set in Master mode, then BCLK2 is output at all times, including when none of the AIF2 audio channels is enabled.



The AIF2 interface can be tri-stated by setting the AIF2\_TRI register. When this bit is set, then all of the AIF2 outputs are un-driven (high-impedance). The AIF2\_TRI register only affects those pins which are configured for AIF2 functions; it does not affect pins which are configured for other functions.

REGISTER ADDRESS	BIT	LABEL	DEFAULT	DESCRIPTION
R786 (0312h) AIF2 Master/Slave	15	AIF2_TRI	0	AIF2 Audio Interface tri-state 0 = AIF2 pins operate normally 1 = Tri-state all AIF2 interface pins Note that pins not configured as AIF2 functions are not affected by this register.
	14	AIF2_MSTR	0	AIF2 Audio Interface Master Mode Select 0 = Slave mode 1 = Master mode
	13	AIF2_CLK_FRC	0	Forces BCLK2 and LRCLK2 to be enabled when all AIF2 audio channels are disabled. 0 = Normal 1 = BCLK2 and LRCLK2 always enabled in Master mode
	12	AIF2_LRCLK_FRC	0	Forces LRCLK2 to be enabled when all AIF2 audio channels are disabled. 0 = Normal 1 = LRCLK2 always enabled in Master mode

**Table 94 AIF2 Master / Slave and Tri-state Control**

#### AIF2 - SIGNAL PATH ENABLE

The AIF2 interface supports two input channels and two output channels. Each of the available channels can be enabled or disabled using the register bits defined in Table 95. These register controls are illustrated in Figure 66.

REGISTER ADDRESS	BIT	LABEL	DEFAULT	DESCRIPTION
R4 (0004h) Power Management (4)	13	AIF2ADCL_ENA	0	Enable AIF2ADC (Left) output path 0 = Disabled 1 = Enabled This bit must be set for AIF2 or AIF3 output of the AIF2ADC (Left) signal.
	12	AIF2ADCR_ENA	0	Enable AIF2ADC (Right) output path 0 = Disabled 1 = Enabled This bit must be set for AIF2 or AIF3 output of the AIF2ADC (Left) signal.
R5 (0005h) Power Management (5)	13	AIF2DACL_ENA	0	Enable AIF2DAC (Left) input path 0 = Disabled 1 = Enabled
	12	AIF2DACR_ENA	0	Enable AIF2DAC (Right) input path 0 = Disabled 1 = Enabled
R792 (0318h) AIF2 Tx Control	1	AIF2TXL_ENA	1	Enable AIF2DAC (Left) input path 0 = Disabled 1 = Enabled This bit must be set for AIF2 output of the AIF2ADC (Left) signal. For AIF3 output only, this bit can be set to 0.

REGISTER ADDRESS	BIT	LABEL	DEFAULT	DESCRIPTION
	0	AIF2TXR_ENA	1	Enable AIF2DAC (Right) input path 0 = Disabled 1 = Enabled This bit must be set for AIF2 output of the AIF2ADC (Left) signal. For AIF3 output only, this bit can be set to 0.

Table 95 AIF2 Signal Path Enable

**AIF2 - BCLK AND LRCLK CONTROL**

The BCLK2 frequency is controlled relative to AIF2CLK by the AIF2\_BCLK\_DIV divider. See “Clocking and Sample Rates” for details of the AIF2 clock, AIF2CLK.

The LRCLK2 frequency is controlled relative to BCLK2 by the AIF2DAC\_RATE divider. Note that the LRCLK2 signal is shared by the AIF2 input and AIF2 output paths; accordingly, the AIF2 input and AIF2 output must always operate at the same sample rate.

In Master mode, the LRCLK2 output is generated by the WM1811A when any of the AIF2 channels is enabled.

In Slave mode, the LRCLK2 output is disabled by default to allow another digital audio interface to drive this pin. It is also possible to force the LRCLK2 signal to be output, using the AIF2DAC\_LRCLK\_DIR register bit, allowing mixed master and slave modes.

The BCLK2 and LRCLK2 output can be inverted using the AIF2\_BCLK\_INV and AIF2DAC\_LRCLK\_INV register bits respectively.

Note that in Slave mode, when BCLK2 is an input, the AIF2\_BCLK\_INV register selects the polarity of the received BCLK2 signal. Under default conditions, DACDAT2 input is captured on the rising edge of BCLK2, as illustrated in Figure 4. When AIF2\_BCLK\_INV = 1, DACDAT2 input is captured on the falling edge of BCLK2.

The AIF2 clock generators are controlled as illustrated in Figure 65.

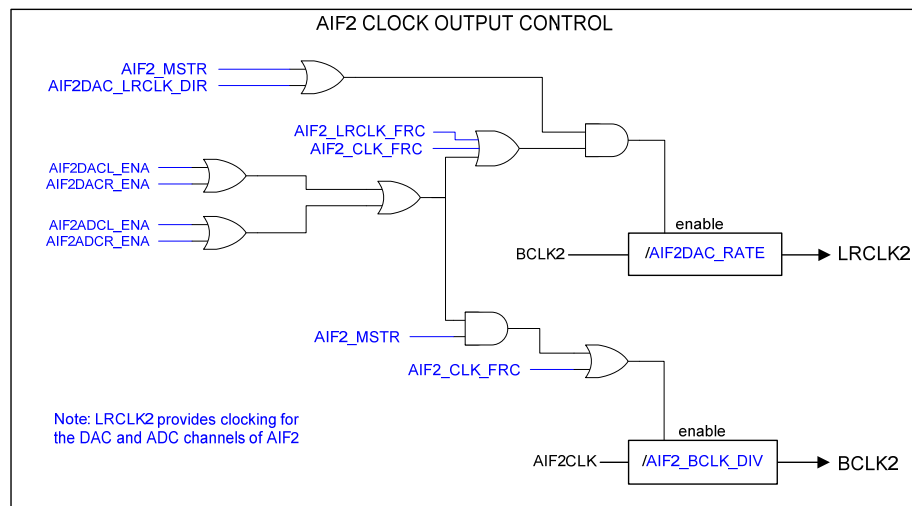

Figure 65 Audio Interface 2 - BCLK and LRCLK Control

REGISTER ADDRESS	BIT	LABEL	DEFAULT	DESCRIPTION
R784 (0310h) AIF2 Control (1)	8	AIF2_BCLK_INV	0	BCLK2 Invert 0 = BCLK2 not inverted 1 = BCLK2 inverted Note that AIF2_BCLK_INV selects the BCLK2 polarity in Master mode and in Slave mode.
R787 (0313h) AIF2 BCLK	8:4	AIF2_BCLK_DIV [4:0]	00100	BCLK2 Rate 00000 = AIF2CLK 00001 = AIF2CLK / 1.5 00010 = AIF2CLK / 2 00011 = AIF2CLK / 3 00100 = AIF2CLK / 4 00101 = AIF2CLK / 5 00110 = AIF2CLK / 6 00111 = AIF2CLK / 8 01000 = AIF2CLK / 11 01001 = AIF2CLK / 12 01010 = AIF2CLK / 16 01011 = AIF2CLK / 22 01100 = AIF2CLK / 24 01101 = AIF2CLK / 32 01110 = AIF2CLK / 44 01111 = AIF2CLK / 48 10000 = AIF2CLK / 64 10001 = AIF2CLK / 88 10010 = AIF2CLK / 96 10011 = AIF2CLK / 128 10100 = AIF2CLK / 176 10101 = AIF2CLK / 192 10110 - 11111 = Reserved
R789 (0315h) AIF2DAC LRCLK	12	AIF2DAC_LRCLK_INV	0	Right, left and I <sup>2</sup> S modes – LRCLK2 polarity 0 = normal LRCLK2 polarity 1 = invert LRCLK2 polarity Note that AIF2DAC_LRCLK_INV selects the LRCLK2 polarity in Master mode and in Slave mode.
				DSP Mode – mode A/B select (AIF2 input) 0 = MSB is available on 2nd BCLK2 rising edge after LRCLK2 rising edge (mode A) 1 = MSB is available on 1st BCLK2 rising edge after LRCLK2 rising edge (mode B)
	11	AIF2DAC_LRCLK_DIR	0	Allows LRCLK2 to be enabled in Slave mode 0 = Normal 1 = LRCLK2 enabled in Slave mode
	10:0	AIF2DAC_RATE [10:0]	040h	LRCLK2 Rate LRCLK2 clock output = BCLK2 / AIF2DAC_RATE  Integer (LSB = 1) Valid from 8..2047

Table 96 AIF2 BCLK and LRCLK Control

**AIF2 - DIGITAL AUDIO DATA CONTROL**

The register bits controlling the audio data format, word length, left/right channel selection and TDM control for AIF2 are described in Table 97.

When TDM mode is enabled on AIF2, the WM1811A can transmit and receive audio data in Slot 0 or Slot 1. In this case, the ADCDAT2 output is tri-stated during the unused timeslot, allowing another device to transmit data on the same pin. See "Signal Timing Requirements" for the associated timing details. (Note that, when TDM is not enabled on AIF2, the ADCDAT2 output is driven logic '0' during the unused timeslot.)

In DSP mode, the left channel MSB is available on either the 1<sup>st</sup> (mode B) or 2<sup>nd</sup> (mode A) rising edge of BCLK following a rising edge of LRCLK (assuming default BCLK polarity).

When the AIF2DAC\_LRCLK\_INV bit is set in DSP mode, then DSP Mode B is selected for the AIF2 digital input (playback) signal path. When the AIF2DAC\_LRCLK\_INV bit is not set, then DSP Mode A is selected.

When the AIF2ADC\_LRCLK\_INV bit is set in DSP mode, then DSP Mode B is selected for the AIF2 digital output (record) signal path. When the AIF2ADC\_LRCLK\_INV bit is not set, then DSP Mode A is selected.

Note that the DSP Mode is selected independently for the input/output paths of each digital audio interface. The LRCLK signal is common for both paths so, for typical applications, the AIF2DAC\_LRCLK\_INV and AIF2ADC\_LRCLK\_INV bits should be set to the same value. The AIF2DAC\_LRCLK\_INV bit is defined in Table 96.

A digital gain function is available at the audio interface input path to boost the DAC volume when a small signal is received on DACDAT2. This is controlled using the AIF2DAC\_BOOST register. To prevent clipping, this function should not be used when the boosted data is expected to be greater than 0dBFS.

REGISTER ADDRESS	BIT	LABEL	DEFAULT	DESCRIPTION
R784 (0310h) AIF2 Control (1)	15	AIF2ADCL_SRC	0	AIF2 Left Digital Audio interface source 0 = Left ADC data is output on left channel 1 = Right ADC data is output on left channel
	14	AIF2ADCR_SRC	1	AIF2 Right Digital Audio interface source 0 = Left ADC data is output on right channel 1 = Right ADC data is output on right channel
	13	AIF2ADC_TDM	0	AIF2 transmit (ADC) TDM Enable 0 = Normal ADCDAT2 operation 1 = TDM enabled on ADCDAT2
	12	AIF2ADC_TDM_CHAN	0	AIF2 transmit (ADC) TDM Slot Select 0 = Slot 0 1 = Slot 1
	6:5	AIF2_WL [1:0]	10	AIF2 Digital Audio Interface Word Length 00 = 16 bits 01 = 20 bits 10 = 24 bits 11 = 32 bits Note - 8-bit modes can be selected using the "Companding" control bits.
	4:3	AIF2_FMT [1:0]	10	AIF2 Digital Audio Interface Format 00 = Right justified 01 = Left justified 10 = I <sup>2</sup> S Format 11 = DSP Mode
R785 (0311h) AIF2 Control (2)	15	AIF2DACL_SRC	0	AIF2 Left Receive Data Source Select 0 = Left DAC receives left interface data 1 = Left DAC receives right interface data

REGISTER ADDRESS	BIT	LABEL	DEFAULT	DESCRIPTION
	14	AIF2DACR_SRC	1	AIF2 Right Receive Data Source Select 0 = Right DAC receives left interface data 1 = Right DAC receives right interface data
	13	AIF2DAC_TDM	0	AIF2 receive (DAC) TDM Enable 0 = Normal DACDAT2 operation 1 = TDM enabled on DACDAT2
	12	AIF2DAC_TDM_CHAN	0	AIF2 receive(DAC) TDM Slot Select 0 = Slot 0 1 = Slot 1
	11:10	AIF2DAC_BOOST [1:0]	00	AIF2 Input Path Boost 00 = 0dB 01 = +6dB (input must not exceed -6dBFS) 10 = +12dB (input must not exceed -12dBFS) 11 = +18dB (input must not exceed -18dBFS)
R788 (0314h) AIF2ADC LRCLK	12	AIF2ADC_LRCLK_INV	0	DSP Mode – mode A/B select (AIF2 output) 0 = MSB is available on 2nd BCLK2 rising edge after LRCLK2 rising edge (mode A) 1 = MSB is available on 1st BCLK2 rising edge after LRCLK2 rising edge (mode B)
R790 (0316h) AIF2 DAC Data	1	AIF2DACL_DAT_INV	0	AIF2 Left Receive Data Invert 0 = Not inverted 1 = Inverted
	0	AIF2DACR_DAT_INV	0	AIF2 Right Receive Data Invert 0 = Not inverted 1 = Inverted
R791 (0317h) AIF2 ADC Data	1	AIF2ADCL_DAT_INV	0	AIF2 Left Transmit Data Invert 0 = Not inverted 1 = Inverted
	0	AIF2ADCR_DAT_INV	0	AIF2 Right Transmit Data Invert 0 = Not inverted 1 = Inverted

Table 97 AIF2 Digital Audio Data Control

**AIF2 - MONO MODE**

AIF2 can be configured to operate in mono DSP mode by setting AIF2\_MONO = 1 as described in Table 98. Note that mono mode is only supported in DSP mode, ie when AIF2\_FMT = 11.

In mono mode, the Left channel data or the Right channel data may be selected for output on ADCDAT2. The selected channel is determined by the AIF2ADCL\_ENA and AIF2ADCR\_ENA bits. (If both bits are set, then the Right channel data is selected.)

In mono mode, the DACDAT2 input can be enabled on the Left and/or Right signal paths using the AIF2DACL\_ENA and AIF2DACR\_ENA bits. The mono input can be enabled on both paths at the same time if required.

REGISTER ADDRESS	BIT	LABEL	DEFAULT	DESCRIPTION
R785 (0311h) AIF2 Control (2)	8	AIF2_MONO	0	AIF2 DSP Mono Mode 0 = Disabled 1 = Enabled Note that Mono Mode is only supported when AIF2_FMT = 11.

Table 98 AIF2 Mono Mode Control

**AIF2 - COMPANDING**

The WM1811A supports A-law and  $\mu$ -law companding on both transmit (ADC) and receive (DAC) sides of AIF2. This is configured using the register bits described in Table 99.

For more details on Companding, see the Audio Interface AIF1 description above.

REGISTER ADDRESS	BIT	LABEL	DEFAULT	DESCRIPTION
R785 (0311h) AIF2 Control (2)	4	AIF2DAC_COMP	0	AIF2 Receive Companding Enable 0 = Disabled 1 = Enabled
	3	AIF2DAC_COMP_MODE	0	AIF2 Receive Companding Type 0 = $\mu$ -law 1 = A-law
	2	AIF2ADC_COMP	0	AIF2 Transmit Companding Enable 0 = Disabled 1 = Enabled
	1	AIF2ADC_COMP_MODE	0	AIF2 Transmit Companding Type 0 = $\mu$ -law 1 = A-law

**Table 99 AIF2 Companding**

**AIF2 - LOOPBACK**

The AIF2 interface can provide a Loopback option. When the AIF2\_LOOPBACK bit is set, then AIF2 digital audio output is routed to the AIF2 digital audio input. The normal input (DACDAT2) is not used when AIF2 Loopback is enabled.

REGISTER ADDRESS	BIT	LABEL	DEFAULT	DESCRIPTION
R785 (0311h) AIF2 Control (2)	0	AIF2_LOOPBACK	0	AIF2 Digital Loopback Function 0 = No loopback 1 = Loopback enabled (ADCDAT2 data output is directly input to DACDAT2 data input).

**Table 100 AIF2 Loopback**

**AIF2 - DIGITAL PULL-UP AND PULL-DOWN**

The WM1811A provides integrated pull-up and pull-down resistors on each of the DACDAT2, DACLRCLK2 and BCLK2 pins. This provides a flexible capability for interfacing with other devices.

Each of the pull-up and pull-down resistors can be configured independently using the register bits described in Table 101. Note that if the Pull-up and Pull-down are both enabled for any pin, then the pull-up and pull-down will be disabled.

REGISTER ADDRESS	BIT	LABEL	DEFAULT	DESCRIPTION
R1794 (0702h) Pull Control (BCLK2)	14	BCLK2_PU	0	BCLK2 Pull-up enable 0 = Disabled 1 = Enabled
	13	BCLK2_PD	1	BCLK2 Pull-down enable 0 = Disabled 1 = Enabled
R1795 (0703h) Pull Control (DACLRCLK2)	14	DACLRCLK2_PU	0	DACLRCLK2 Pull-up enable 0 = Disabled 1 = Enabled
	13	DACLRCLK2_PD	1	DACLRCLK2 Pull-down enable 0 = Disabled 1 = Enabled
R1796 (0704h) Pull Control (DACDAT2)	14	DACDAT2_PU	0	DACDAT2 Pull-up enable 0 = Disabled 1 = Enabled
	13	DACDAT2_PD	1	DACDAT2 Pull-down enable 0 = Disabled 1 = Enabled

**Table 101 AIF2 Digital Pull-Up and Pull-Down Control**

**AIF3 - SIGNAL PATH CONFIGURATION AND TRI-STATE CONTROL**

The AIF3 interface provides Mono PCM digital audio paths to/from the AIF2 DSP functions. The AIF3 interface can also support stereo digital audio paths via multiplexers to provide alternate connections to AIF1 or AIF2. The relevant multiplexers are illustrated in Figure 66.

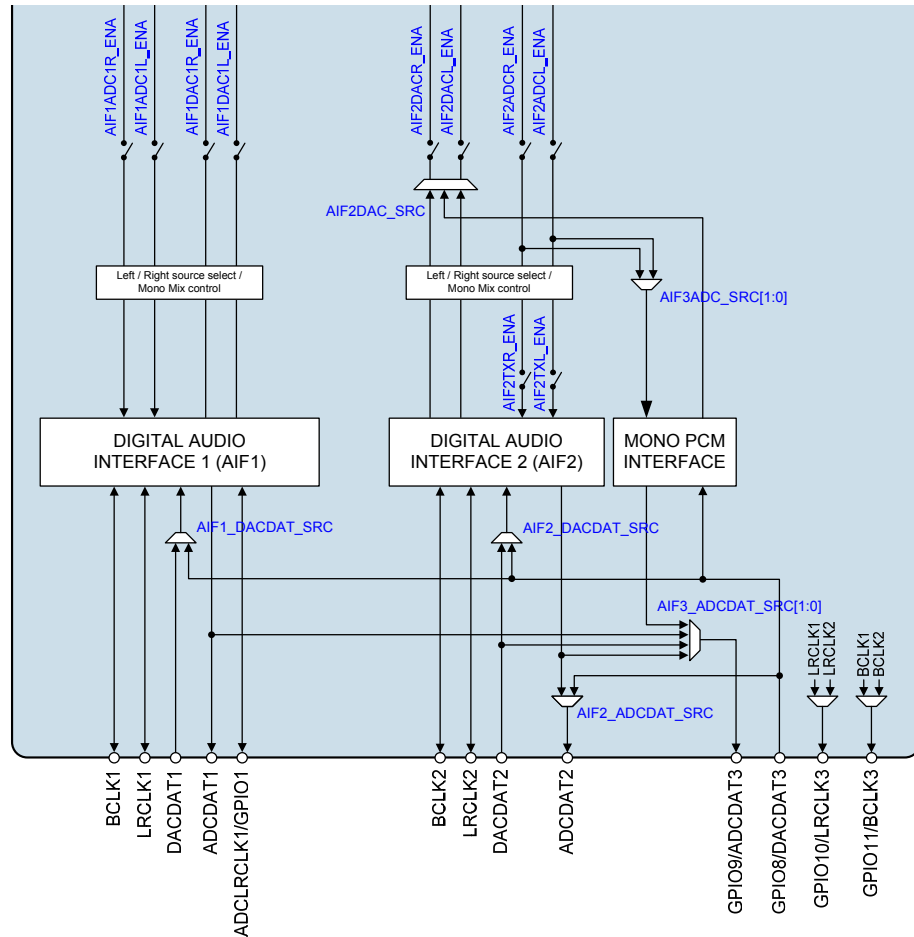

**Figure 66 Audio Interface AIF3 Configuration**

Note that all of the AIF3 connections are supported on pins which also provide GPIO functions. These pins must be configured as AIF functions when used as audio interface pins. See "General Purpose Input/Output".

The GPIO8 pin supports the DACDAT3 function, which provides the input to the AIF3 Mono PCM interface.

When AIF3 Mono PCM input is used, this must be configured as an input to the AIF2 input paths using the AIF2DAC\_SRC register as described in Table 102. The AIF3 Mono input may be selected on either channel (Left or Right), with AIF2 input enabled on the opposite channel at the same time.

When AIF3 Mono PCM input is used, the AIF2 input paths must be enabled using the AIF2DACR\_ENA and AIF2DACL\_ENA register bits defined in Table 95.

The DACDAT3 input pin can also be used as an input (mono or stereo) to AIF1 or AIF2. The data input source for AIF1 is selected using the AIF1\_DACDAT\_SRC register. The data input source for AIF2 is selected using the AIF2\_DACDAT\_SRC register.

The DACDAT3 input pin can also be routed to the ADCDAT2 output. The ADCDAT2 source is selected using the AIF2\_ADCDAT\_SRC register.



The GPIO9 pin supports the ADCDAT3 function, which supports the output from the AIF3 Mono PCM interface. The source for the ADCDAT3 pin is selected using the AIF3\_ADCCDAT\_SRC register.

When AIF3 Mono PCM output is used, the data source must be configured using the AIF3ADC\_SRC register; this selects either the Left or Right AIF2 output paths as the data source.

When AIF3 Mono PCM output is used, the AIF2 output paths must be enabled using the AIF2ADCR\_ENA and AIF2ADCL\_ENA register bits. Note that, if AIF3 Mono PCM output is required and AIF2 output is not used, then the AIF2 output can be disabled using the AIF2TXL\_ENA and AIF2TXR\_ENA registers. See Table 95 for details of these registers.

The ADCDAT3 pin can also be used as an alternate data output (mono or stereo) from AIF1 or AIF2, or can be connected to the DACDAT2 data input.

The AIF3 interface can be tri-stated by setting the AIF3\_TRI register. When this bit is set, then all of the AIF3 outputs are un-driven (high-impedance). The AIF3\_TRI register only affects those pins which are configured for AIF3 functions; it does not affect pins which are configured for other functions.

The AIF3 control registers are described in Table 102.

REGISTER ADDRESS	BIT	LABEL	DEFAULT	DESCRIPTION
R6 (0006h) Power Management (6)	10:9	AIF3ADC_SRC [1:0]	00	AIF3 Mono PCM output source select 00 = None 01 = AIF2ADC (Left) output path 10 = AIF2ADC (Right) output path 11 = Reserved
	8:7	AIF2DAC_SRC [1:0]	00	AIF2 input path select 00 = Left and Right inputs from AIF2 01 = Left input from AIF2; Right input from AIF3 10 = Left input from AIF3; Right input from AIF2 11 = Reserved
	5	AIF3_TRI	0	AIF3 Audio Interface tri-state 0 = AIF3 pins operate normally 1 = Tri-state all AIF3 interface pins Note that pins not configured as AIF3 functions are not affected by this register.
	4:3	AIF3_ADCCDAT_SRC [1:0]	00	GPIO9/ADCCDAT3 Source select 00 = AIF1 ADCDAT1 01 = AIF2 ADCDAT2 10 = DACDAT2 11 = AIF3 Mono PCM output Note that GPIO9 must be configured as ADCDAT3.
	2	AIF2_ADCCDAT_SRC	0	ADCCDAT2 Source select 0 = AIF2 ADCDAT2 1 = GPIO8/DACDAT3 For selection 1, the GPIO8 pin must also be configured as DACDAT3.
	1	AIF2_DACDAT_SRC	0	AIF2 DACDAT Source select 0 = DACDAT2 1 = GPIO8/DACDAT3 For selection 1, the GPIO8 pin must also be configured as DACDAT3.

REGISTER ADDRESS	BIT	LABEL	DEFAULT	DESCRIPTION
	0	AIF1_DACDAT_SRC	0	AIF1 DACDAT Source select 0 = DACDAT1 1 = GPIO8/DACDAT3 Note that, for selection 1, the GPIO8 pin must be configured as DACDAT3.

Table 102 AIF3 Signal Path Configuration

**AIF3 - BCLK AND LRCLK CONTROL**

The GPIO10 pin supports the LRCLK3 function. When configured as LRCLK3, this pin outputs the LRCLK signal from AIF1 or AIF2. The applicable AIF source is determined automatically as defined in Table 103. Note that the LRCLK3 signal is also controlled by the logic illustrated in Figure 62 (AIF1) or Figure 65 (AIF2), depending on the selected AIF source.

The GPIO11 pin supports the BCLK3 function. When configured as BCLK3, this pin outputs the BCLK signal from AIF1 or AIF2. The applicable AIF source is determined automatically as defined in Table 103. Note that the BCLK3 signal is also controlled by the logic illustrated in Figure 62 (AIF1) or Figure 65 (AIF2), depending on the selected AIF source.

CONDITION	DESCRIPTION
AIF1_DACDAT_SRC = 1 (DACDAT3 selected as AIF1 data input)  or  AIF3_ADCCDAT_SRC[1:0] = 00 (AIF1 data output selected on ADCCDAT3)	AIF1 selected as BCLK3 / LRCLK3 source
All other conditions	AIF2 selected as BCLK3 / LRCLK3 source

Table 103 BCLK3 / LRCLK3 Configuration

The LRCLK3 output can be inverted by setting the AIF3\_LRCLK\_INV register. Note that AIF3 operates in Master mode only.

REGISTER ADDRESS	BIT	LABEL	DEFAULT	DESCRIPTION
R800 (0320h) AIF3 Control (1)	7	AIF3_LRCLK_INV	0	Right, left and I <sup>2</sup> S modes – LRCLK3 polarity 0 = normal LRCLK3 polarity 1 = invert LRCLK3 polarity  DSP Mode – mode A/B select 0 = MSB is available on 2nd BCLK3 rising edge after LRCLK3 rising edge (mode A) 1 = MSB is available on 1st BCLK3 rising edge after LRCLK3 rising edge (mode B)

Table 104 AIF3 LRCLK Control

**AIF3 - DIGITAL AUDIO DATA CONTROL**

The register bits controlling the AIF3Mono PCM interface are described in Table 105.

Note that these registers control the AIF3 Mono PCM interface only; they are not applicable to the ADCDAT3 and DACDAT3 signal paths when these pins are selected as alternate inputs to the AIF1 or AIF2 interfaces.

The audio data format for AIF3 is set the same as AIF2; this is controlled using the AIF2\_FMT register, as described in see Table 97.

In DSP mode, the AIF3 Mono channel MSB is available on either the 1<sup>st</sup> (mode B) or 2<sup>nd</sup> (mode A) rising edge of BCLK following a rising edge of LRCLK. The applicable DSP mode is selected using the AIF3\_LRCLK\_INV bit, as described in Table 104.

In Left justified, Right justified and I2S modes, the AIF3 Mono interface data is transmitted and received in the Left channel data bits of the ADCDAT3 and DACDAT3 channels.

A digital gain function is available at the audio interface input path to boost the DAC volume when a small signal is received on DACDAT3. This is controlled using the AIF3DAC\_BOOST register. To prevent clipping, this function should not be used when the boosted data is expected to be greater than 0dBFS.

REGISTER ADDRESS	BIT	LABEL	DEFAULT	DESCRIPTION
R800 (0320h) AIF3 Control (1)	6:5	AIF3_WL [1:0]	10	AIF3 Digital Audio Interface Word Length 00 = 16 bits 01 = 20 bits 10 = 24 bits 11 = 32 bits Note - 8-bit modes can be selected using the "Companding" control bits. Note that this controls the AIF3 Mono PCM interface path only; it does not affect AIF3 inputs/outputs routed to AIF1 or AIF2.
R801 (0321h) AIF3 Control (2)	11:10	AIF3DAC_BOOST [1:0]	00	AIF3 Input Path Boost 00 = 0dB 01 = +6dB (input must not exceed -6dBFS) 10 = +12dB (input must not exceed -12dBFS) 11 = +18dB (input must not exceed -18dBFS) Note that this controls the AIF3 Mono PCM interface path only; it does not affect DACDAT3 input to AIF1 or AIF2.
R802 (0322h) AIF3DAC Data	0	AIF3DAC_DATA_INVERT	0	AIF3 Receive Data Invert 0 = Not inverted 1 = Inverted Note that this controls the AIF3 Mono PCM interface path only; it does not affect DACDAT3 input to AIF1 or AIF2.
R803 (0323h) AIF3ADC Data	0	AIF3ADC_DATA_INVERT	0	AIF3 Transmit Data Invert 0 = Not inverted 1 = Inverted Note that this controls the AIF3 Mono PCM interface path only; it does not affect ADCDAT3 output from AIF1 or AIF2.

**Table 105 AIF3 Digital Audio Data Control**

**AIF3 - COMPANDING**

The WM1811A supports A-law and  $\mu$ -law companding on both transmit (ADC) and receive (DAC) sides of AIF3. This is configured using the register bits described in Table 106.

Note that these registers control the AIF3 Mono PCM interface only; they are not applicable to the ADCDAT3 and DACDAT3 signal paths when these pins are selected as alternate inputs to the AIF1 or AIF2 interfaces.

For more details on Companding, see the Audio Interface AIF1 description above.

REGISTER ADDRESS	BIT	LABEL	DEFAULT	DESCRIPTION
R801 (0321h) AIF3 Control (2)	4	AIF3DAC_C OMP	0	AIF3 Receive Companding Enable 0 = Disabled 1 = Enabled Note that this controls the AIF3 Mono PCM interface path only; it does not affect DACDAT3 input to AIF1 or AIF2.
	3	AIF3DAC_C OMPMODE	0	AIF3 Receive Companding Type 0 = $\mu$ -law 1 = A-law Note that this controls the AIF3 Mono PCM interface path only; it does not affect DACDAT3 input to AIF1 or AIF2.
	2	AIF3ADC_C OMP	0	AIF3 Transmit Companding Enable 0 = Disabled 1 = Enabled Note that this controls the AIF3 Mono PCM interface path only; it does not affect ADCDAT3 output from AIF1 or AIF2.
	1	AIF3ADC_C OMPMODE	0	AIF3 Transmit Companding Type 0 = $\mu$ -law 1 = A-law Note that this controls the AIF3 Mono PCM interface path only; it does not affect ADCDAT3 output from AIF1 or AIF2.

**Table 106 AIF3 Companding**

**AIF3 - LOOPBACK**

The AIF3 interface can provide a Loopback option. When the AIF3\_LOOPBACK bit is set, then AIF3 Mono PCM output is routed to the AIF3Mono PCM input. The normal input (DACDAT3) is not used when AIF3 Loopback is enabled.

REGISTER ADDRESS	BIT	LABEL	DEFAULT	DESCRIPTION
R801 (0321h) AIF3 Control (2)	0	AIF3_LOOP BACK	0	AIF3 Digital Loopback Function 0 = No loopback 1 = Loopback enabled (AIF3 Mono PCM data output is directly input to AIF3 Mono PCM data input).

**Table 107 AIF3 Loopback**

## CLOCKING AND SAMPLE RATES

The WM1811A requires a clock for each of the Digital Audio Interfaces (AIF1 and AIF2). These may be derived from a common clock reference, or from independent references. Under typical clocking configurations, many commonly-used audio sample rates can be derived directly from the external reference; for additional flexibility, the WM1811A incorporates two Frequency Locked Loop (FLL) circuits to perform frequency conversion and filtering.

External clock signals may be connected via MCLK1 and MCLK2. In AIF Slave modes, the BCLK or LRCLK signals may be used as a reference for the AIF clocks.

The WM1811A performs stereo full-duplex sample rate conversion between the audio interfaces AIF1 and AIF2, enabling digital audio to be routed between the interfaces, and asynchronous audio data to be mixed together. See "Sample Rate Conversion" for further details.

In AIF Slave modes, it is important to ensure the applicable AIF clock (AIF1CLK or AIF2CLK) is synchronised with the associated external LRCLK. This can be achieved by selecting an MCLK input that is derived from the same reference as the LRCLK, or can be achieved by selecting the external BCLK or LRCLK signals as a reference input to one of the FLLs, as a source for the AIF clock.

If the AIF clock is not synchronised with the LRCLK, then clicks arising from dropped or repeated audio samples will occur, due to the inherent tolerances of multiple, asynchronous, system clocks. See "Applications Information" for further details on valid clocking configurations.

Clocking for the Audio Interfaces is provided by AIF1CLK and AIF2CLK for AIF1 and AIF2 respectively. An additional internal clock, SYSCLK is derived from either AIF1CLK or AIF2CLK in order to support the DSP core functions, Charge Pump, Class D switching amplifier, DC servo control and other internal functions.

The following operating limits must be observed when configuring the WM1811A clocks. Failure to observe these limits will result in degraded performance and/or incorrect system functionality. Latency in the WM1811A signal paths is reduced at high SYSCLK frequencies; power consumption is reduced at low SYSCLK frequencies.

- $\text{SYSCLK} \leq 12.5\text{MHz}$
- $\text{SYSCLK} \geq 4.096\text{MHz}$
- $\text{SYSCLK} \geq 256 \times f_s$  (where  $f_s$  = fastest audio sample rate in use)
  
- $\text{AIF1CLK} \leq 12.5\text{MHz}$
- $\text{AIF1CLK} \geq 256 \times \text{AIF1 sample rate (AIF1\_SR)}$
  
- $\text{AIF2CLK} \leq 12.5\text{MHz}$
- $\text{AIF2CLK} \geq 256 \times \text{AIF2 sample rate (AIF2\_SR)}$

Note that, if DAC\_OS128 = 0 and ADC\_OS128 = 0, then a slower SYSCLK frequency is possible; in this case, the requirement is  $\text{SYSCLK} \geq 2.048\text{MHz}$ .

Note that, under specific operating conditions, clocking ratios of 128 x  $f_s$  and 192 x  $f_s$  are possible; this is described in the "Digital to Analogue Converter (DAC)" section.

The SYSCLK frequency must be  $\geq 256 \times f_s$ , (where  $f_s$  is the faster rate of AIF1\_SR or AIF2\_SR). The SYSCLK frequency is derived from AIF1CLK or AIF2CLK, as selected by the SYSCLK\_SRC register (see Table 112).

Note that the bandwidth of the digital audio mixing paths will be determined by the sample rate of whichever AIF is selected as the SYSCLK source. When using only one audio interface, the active interface should be selected as the SYSCLK source. For best audio performance when using AIF1 and AIF2 simultaneously, the SYSCLK source must select the AIF with the highest sample rate (AIF<sub>n</sub>\_SR).

The AIF<sub>n</sub>CLK / fs ratio is the ratio of AIF<sub>n</sub>CLK to the AIF<sub>n</sub> sample rate, where 'n' identifies the applicable audio interface AIF1 or AIF2. The AIF clocking ratio and sample rate are set by the AIF<sub>n</sub>CLK\_RATE and AIF<sub>n</sub>\_SR register fields, defined in Table 109 and Table 111.

Note that, in the case of mixed input/output path sample rates (supported on AIF1 only), then AIF<sub>n</sub>CLK\_RATE and AIF<sub>n</sub>\_SR are set according to the higher of the two sample rates.

The clocking configuration for AIF1CLK, AIF2CLK and SYSCLK is illustrated in Figure 67. The SYSCLK\_SRC register is defined in Table 112.

The WM1811A provides integrated pull-up and pull-down resistors on the MCLK1 and MCLK2 pins. This provides a flexible capability for interfacing with other devices. This is configured as described in Table 112. Note that if the Pull-up and Pull-down are both enabled for any pin, then the pull-up and pull-down will be disabled.

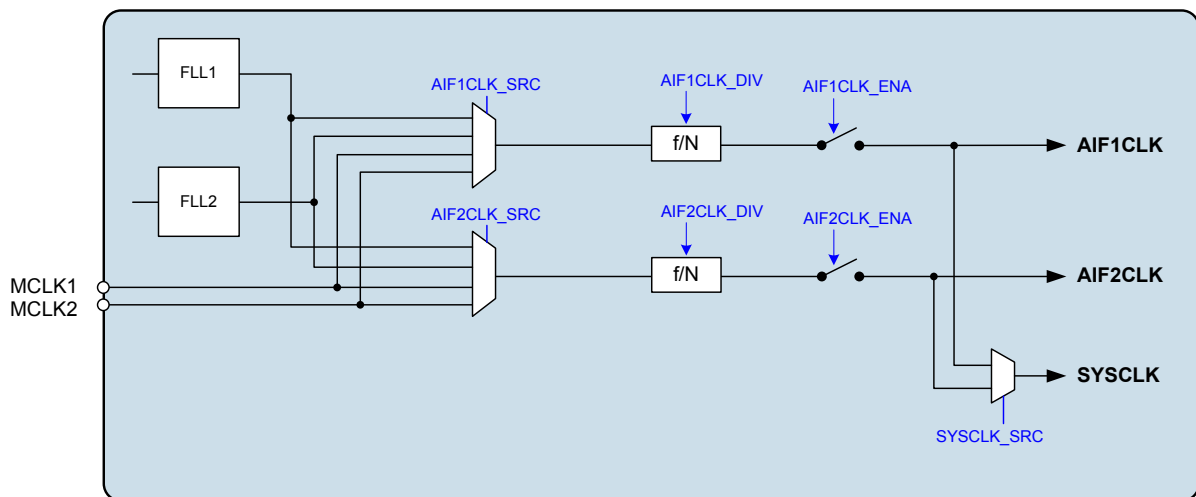

Figure 67 Audio Interface Clock Control

### AIF1CLK ENABLE

The AIF1CLK\_SRC register is used to select the AIF1CLK source. The source may be MCLK1, MCLK2, FLL1 or FLL2. If either of the Frequency Locked Loops is selected as the source, then the FLL(s) must be enabled and configured as described later.

The AIF1CLK clock may be adjusted by the AIF1CLK\_DIV divider, which provides a divide-by-two option. The selected source may also be inverted by setting the AIF1CLK\_INV bit.

The maximum AIF1CLK frequency is specified in the "Electrical Characteristics" section. Note that, when AIF1CLK\_DIV = 1, the maximum frequency limit applies to the divided-down AIF1CLK frequency.

The AIF1CLK is enabled by the register bit AIF1CLK\_ENA. This bit should be set to 0 when reconfiguring the clock sources. It is not recommended to change AIF1CLK\_SRC while the AIF1CLK\_ENA bit is set.

REGISTER ADDRESS	BIT	LABEL	DEFAULT	DESCRIPTION
R512 (0200h) AIF 1 Clocking (1)	4:3	AIF1CLK_SRC	00	AIF1CLK Source Select 00 = MCLK1 01 = MCLK2 10 = FLL1 11 = FLL2
	2	AIF1CLK_INV	0	AIF1CLK Invert 0 = AIF1CLK not inverted 1 = AIF1CLK inverted
	1	AIF1CLK_DIV	0	AIF1CLK Divider 0 = AIF1CLK 1 = AIF1CLK / 2
	0	AIF1CLK_ENA	0	AIF1CLK Enable 0 = Disabled 1 = Enabled

Table 108 AIF1CLK Enable

### AIF1 CLOCKING CONFIGURATION

The WM1811A supports a wide range of standard audio sample rates from 8kHz to 96kHz. The AIF1 clocking configuration is selected using 4 control fields, which are set according to the required AIF digital audio sample rate, and the ADC/DAC clocking rate.

The AIF1\_SR register is set according to the AIF1 sample rate. Note that 88.2kHz and 96kHz modes are supported for AIF1 input (DAC playback) only.

The AIF1CLK\_RATE register is set according to the ratio of AIF1CLK to the AIF1 sample rate. Note that there are some restrictions on the supported clocking ratios, depending on the selected sample rate and operating conditions. The supported configurations are detailed in the "Digital Microphone Interface", "Analogue to Digital Converter (ADC)" and "Digital to Analogue Converter (DAC)" sections, according to each applicable function.

The AIF1 audio interface can support different sample rates for the input data (DAC path) and output data (ADC path) simultaneously. In this case, the AIF1\_SR and AIF1CLK\_RATE fields should be set according to the faster of the two sample rates.

When different sample rates are used for input data (DAC path) and output data (ADC path), the clocking of the slower path is set using AIF1DAC\_DIV (if the AIF input path has the slower sample rate) or AIF1ADC\_DIV (if the AIF output path has the slower sample rate). The appropriate divider is set according to the ratio of the two sample rates.

For example, if AIF1 input uses 48kHz sample rate, and AIF1 output uses 8kHz, then AIF1ADC\_DIV should be set to 110b (divide by 6).

Note that the audio interface cannot support every possible combination of input and output sample rate simultaneously, but only where the ratio of the sample rates matches the available AIF1ADC\_DIV or AIF1DAC\_DIV divider settings.

Note that the WM1811A performs sample rate conversion, where necessary, to provide digital mixing and interconnectivity between the Audio Interfaces and the DSP Core functions. One stereo Sample Rate Converter (SRC) is provided for audio input; a second stereo SRC is provided for audio output. Each SRC is automatically configured on AIF1 or AIF2, depending on the selected Clocking and Sample Rate settings. The WM1811A cannot support configurations that would require SRC on the input or output paths of both interfaces simultaneously. See "Sample Rate Conversion" for further details.

REGISTER ADDRESS	BIT	LABEL	DEFAULT	DESCRIPTION
R513 (0201h) AIF 1 Clocking (2)	5:3	AIF1DAC_DIV	000	<p>Selects the AIF1 input path sample rate relative to the AIF1 output path sample rate.</p> <p>This field should only be changed from default in modes where the AIF1 input path sample rate is slower than the AIF1 output path sample rate.</p> <p>000 = Divide by 1 001 = Divide by 1.5 010 = Divide by 2 011 = Divide by 3 100 = Divide by 4 101 = Divide by 5.5 110 = Divide by 6 111 = Reserved</p>
	2:0	AIF1ADC_DIV	000	<p>Selects the AIF1 output path sample rate relative to the AIF1 input path sample rate.</p> <p>This field should only be changed from default in modes where the AIF1 output path sample rate is slower than the AIF1 input path sample rate.</p> <p>000 = Divide by 1 001 = Divide by 1.5 010 = Divide by 2 011 = Divide by 3 100 = Divide by 4 101 = Divide by 5.5 110 = Divide by 6 111 = Reserved</p>
R528 (0210h) AIF1 Rate	7:4	AIF1_SR	1000	<p>Selects the AIF1 Sample Rate (fs)</p> <p>0000 = 8kHz 0001 = 11.025kHz 0010 = 12kHz 0011 = 16kHz 0100 = 22.05kHz 0101 = 24kHz 0110 = 32kHz 0111 = 44.1kHz 1000 = 48kHz 1001 = 88.2kHz 1010 = 96kHz All other codes = Reserved</p> <p>Note that 88.2kHz and 96kHz modes are supported for AIF1 input (DAC playback) only.</p>
	3:0	AIF1CLK_RAT E	0011	<p>Selects the AIF1CLK / fs ratio</p> <p>0000 = Reserved 0001 = 128 0010 = 192 0011 = 256 0100 = 384 0101 = 512 0110 = 768 0111 = 1024 1000 = 1408 1001 = 1536 All other codes = Reserved</p>

Table 109 AIF1 Clocking Configuration



**AIF2CLK ENABLE**

The AIF2CLK\_SRC register is used to select the AIF2CLK source. The source may be MCLK1, MCLK2, FLL1 or FLL2. If either of the Frequency Locked Loops is selected as the source, then the FLL(s) must be enabled and configured as described later.

The AIF2CLK clock may be adjusted by the AIF2CLK\_DIV divider, which provides a divide-by-two option. The selected source may also be inverted by setting the AIF2CLK\_INV bit.

The maximum AIF2CLK frequency is specified in the “Electrical Characteristics” section. Note that, when AIF2CLK\_DIV = 1, the maximum frequency limit applies to the divided-down AIF2CLK frequency.

The AIF2CLK is enabled by the register bit AIF2CLK\_ENA. This bit should be set to 0 when reconfiguring the clock sources. It is not recommended to change AIF2CLK\_SRC while the AIF2CLK\_ENA bit is set.

REGISTER ADDRESS	BIT	LABEL	DEFAULT	DESCRIPTION
R516 (0204h) AIF 2 Clocking (1)	4:3	AIF2CLK_SRC	00	AIF2CLK Source Select 00 = MCLK1 01 = MCLK2 10 = FLL1 11 = FLL2
	2	AIF2CLK_INV	0	AIF2CLK Invert 0 = AIF2CLK not inverted 1 = AIF2CLK inverted
	1	AIF2CLK_DIV	0	AIF2CLK Divider 0 = AIF2CLK 1 = AIF2CLK / 2
	0	AIF2CLK_ENA	0	AIF2CLK Enable 0 = Disabled 1 = Enabled

**Table 110 AIF2CLK Enable**

**AIF2 CLOCKING CONFIGURATION**

The WM1811A supports a wide range of standard audio sample rates from 8kHz to 96kHz. The AIF2 clocking configuration is selected using 2 control fields, which are set according to the required AIF digital audio sample rate, and the ADC/DAC clocking rate.

The AIF2\_SR register is set according to the AIF2 sample rate. Note that 88.2kHz and 96kHz modes are supported for AIF2 input (DAC playback) only.

The AIF2CLK\_RATE register is set according to the ratio of AIF2CLK to the AIF2 sample rate. Note that there are some restrictions on the supported clocking ratios, depending on the selected sample rate and operating conditions. The supported configurations are detailed in the “Digital Microphone Interface”, “Analogue to Digital Converter (ADC)” and “Digital to Analogue Converter (DAC)” sections, according to each applicable function.

The AIF2 audio interface cannot support different sample rates for the input data (DAC path) and output data (ADC path) simultaneously. The AIF2\_SR register sets the sample rate for both paths.

Note that the WM1811A performs sample rate conversion, where necessary, to provide digital mixing and interconnectivity between the Audio Interfaces and the DSP Core functions. One stereo Sample Rate Converter (SRC) is provided for audio input; a second stereo SRC is provided for audio output. Each SRC is automatically configured on AIF1 or AIF2, depending on the selected Clocking and Sample Rate settings. The WM1811A cannot support configurations that would require SRC on the input or output paths of both interfaces simultaneously. See “Sample Rate Conversion” for further details.

REGISTER ADDRESS	BIT	LABEL	DEFAULT	DESCRIPTION
R529 (0211h) AIF2 Rate	7:4	AIF2_SR	1000	Selects the AIF2 Sample Rate (fs) 0000 = 8kHz 0001 = 11.025kHz 0010 = 12kHz 0011 = 16kHz 0100 = 22.05kHz 0101 = 24kHz 0110 = 32kHz 0111 = 44.1kHz 1000 = 48kHz 1001 = 88.2kHz 1010 = 96kHz All other codes = Reserved Note that 88.2kHz and 96kHz modes are supported for AIF2 input (DAC playback) only.
	3:0	AIF2CLK_RATE	0011	Selects the AIF2CLK / fs ratio 0000 = Reserved 0001 = 128 0010 = 192 0011 = 256 0100 = 384 0101 = 512 0110 = 768 0111 = 1024 1000 = 1408 1001 = 1536 All other codes = Reserved

Table 111 AIF2 Clocking Configuration

### MISCELLANEOUS CLOCK CONTROLS

SYSCLK provides clocking for many of the WM1811A functions. SYSCLK clock is required to support DSP Core functions and also the Charge Pump, Class D switching amplifier, DC servo control and other internal functions.

The SYSCLK\_SRC register is used to select the SYSCLK source. The source may be AIF1CLK or AIF2CLK, as illustrated in Figure 68. Note that the bandwidth of the digital audio mixing paths will be determined by the sample rate of whichever AIF is selected as the SYSCLK source. When using only one audio interface, the active interface should be selected as the SYSCLK source. For best audio performance when using AIF1 and AIF2 simultaneously, the SYSCLK source must select the AIF with the highest sample rate (AIFn\_SR).

The AIF1 DSP processing clock is derived from SYSCLK, and enabled by AIF1DSPCLK\_ENA.

The AIF2 DSP processing clock is derived from SYSCLK, and enabled by AIF2DSPCLK\_ENA.

The clocking of the WM1811A ADC, DAC, digital mixer and digital microphone functions is enabled by setting SYSDSPCLK\_ENA. See "Digital Microphone Interface" for details of the DMICCLK frequency.

Two modes of ADC / Digital Microphone operation can be selected using the ADC\_OSR128 bit. This bit is enabled by default, giving best audio performance. De-selecting this bit provides a low power alternative setting.

A high performance mode of DAC operation can be selected by setting the DAC\_OSR128 bit. When the DAC\_OSR128 bit is set, the audio performance is improved, but power consumption is also increased.

A clock is required for the Charge Pump circuit when the ground-referenced headphone outputs (HPOUT1L and HPOUT1R) are enabled. The Charge Pump clock is derived from SYSCLK whenever the Charge Pump is enabled. The Charge Pump clock division is configured automatically.

A clock is required for the Class D speaker driver circuit when the speaker outputs (SPKOUTL and SPKOUTR) are enabled. The Class D clock is derived from SYSCLK whenever these outputs are enabled in Class D mode. The Class D clock division is configured automatically. See “Analogue Outputs” for details of the Class D switching frequency.

A clock output (OPCLK) derived from SYSCLK may be output on a GPIO pin. This clock is enabled by register bit OPCLK\_ENA, and its frequency of this clock is controlled by OPCLK\_DIV. See General Purpose Input/Output” to configure a GPIO pin for this function.

A slow clock (TOCLK) is derived internally in order to control volume update timeouts when the zero-cross option is selected. This clock is enabled by register bit TOCLK\_ENA, and its frequency is controlled by TOCLK\_DIV.

A de-bounce control is provided for GPIO inputs and for other functions that may be selected as GPIO outputs. The de-bounced clock frequency is controlled by DBCLK\_DIV.

The WM1811A generates a 256kHz clock for internal functions; TOCLK and DBCLK are derived from this 256kHz clock. In order to generate this clock correctly when SYSCLK\_SRC = 0, valid settings are required for AIF1\_SR and AIF1CLK\_RATE. To generate this clock correctly when SYSCLK\_SRC = 1, valid settings are required for AIF2\_SR and AIF2CLK\_RATE.

The WM1811A Clocking is illustrated in Figure 68.

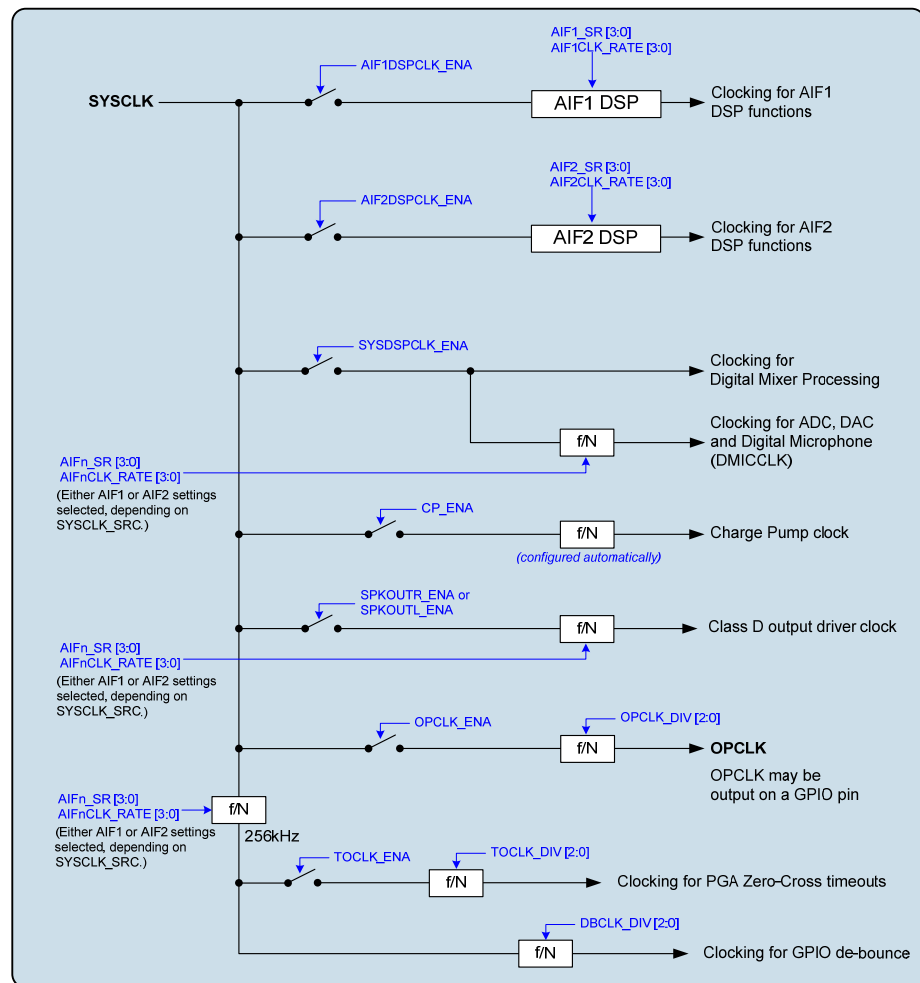

Figure 68 System Clocking

REGISTER ADDRESS	BIT	LABEL	DEFAULT	DESCRIPTION
R2 (0002h) Power Management (2)	11	OPCLK_ENA	0	GPIO Clock Output (OPCLK) Enable 0 = Disabled 1 = Enabled
R520 (0208h) Clocking (1)	4	TOCLK_ENA	0	Slow Clock (TOCLK) Enable 0 = Disabled 1 = Enabled This clock is required for zero-cross timeout.
	3	AIF1DSPCLK_ENA	0	AIF1 Processing Clock Enable 0 = Disabled 1 = Enabled
	2	AIF2DSPCLK_ENA	0	AIF2 Processing Clock Enable 0 = Disabled 1 = Enabled
	1	SYSDSPCLK_ENA	0	Digital Mixing Processor Clock Enable 0 = Disabled 1 = Enabled
	0	SYSCLK_SRC	0	SYSCLK Source Select 0 = AIF1CLK 1 = AIF2CLK
R521 (0209h) Clocking (2)	10:8	TOCLK_DIV	000	Slow Clock (TOCLK ) Divider (Sets TOCLK rate relative to 256kHz.) 000 = Divide by 256 (1kHz) 001 = Divide by 512 (500Hz) 010 = Divide by 1024 (250Hz) 011 = Divide by 2048 (125Hz) 100 = Divide by 4096 (62.5Hz) 101 = Divide by 8192 (31.2Hz) 110 = Divide by 16384 (15.6Hz) 111 = Divide by 32768 (7.8Hz)
	6:4	DBCLK_DIV	000	De-bounce Clock (DBCLK) Divider (Sets DBCLK rate relative to 256kHz.) 000 = Divide by 256 (1kHz) 001 = Divide by 2048 (125Hz) 010 = Divide by 4096 (62.5Hz) 011 = Divide by 8192 (31.2Hz) 100 = Divide by 16384 (15.6Hz) 101 = Divide by 32768 (7.8Hz) 110 = Divide by 65536 (3.9Hz) 111 = Divide by 131072 (1.95Hz)
	2:0	OPCLK_DIV	000	GPIO Output Clock (OPCLK) Divider 0000 = SYSCLK 0001 = SYSCLK / 2 0010 = SYSCLK / 3 0011 = SYSCLK / 4 0100 = SYSCLK / 5.5 0101 = SYSCLK / 6 0110 = SYSCLK / 8 0111 = SYSCLK / 12 1000 = SYSCLK / 16 1001 to 1111 = Reserved

REGISTER ADDRESS	BIT	LABEL	DEFAULT	DESCRIPTION
R1568 (0620h) Oversampling	1	ADC_OSR128	1	ADC / Digital Microphone Oversample Rate Select 0 = Low Power 1 = High Performance
	0	DAC_OSR128	0	DAC Oversample Rate Select 0 = Low Power 1 = High Performance
R1793 (0701h) Pull Control (MCLK2)	14	MCLK2_PU	0	MCLK2Pull-up enable 0 = Disabled 1 = Enabled
	13	MCLK2_PD	1	MCLK2Pull-down enable 0 = Disabled 1 = Enabled
R1824 (0720h) Pull Control (1)	7	MCLK1_PU	0	MCLK1 Pull-up enable 0 = Disabled 1 = Enabled
	6	MCLK1_PD	0	MCLK1 Pull-down enable 0 = Disabled 1 = Enabled

Table 112 System Clocking

**BCLK AND LRCLK CONTROL**

The digital audio interfaces (AIF1 and AIF2) use BCLK and LRCLK signals for synchronisation. In master mode, these are output signals, generated by the WM1811A. In slave mode, these are input signals to the WM1811A. It is also possible to support mixed master/slave operation.

The BCLK and LRCLK signals are controlled as illustrated in Figure 69. See the “Digital Audio Interface Control” section for further details of the relevant control registers.

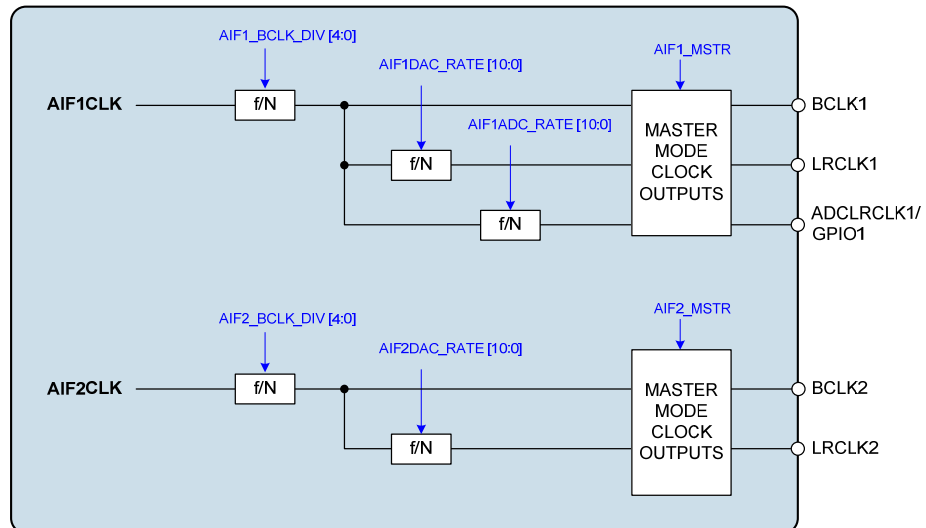

Figure 69 BCLK and LRCLK Control

### CONTROL INTERFACE CLOCKING

Register map access is possible with or without a system clock. Clocking is provided from SYSCLK; the SYSCLK\_SRC register selects either AIF1CLK or AIF2CLK as the applicable SYSCLK source.

When AIF1CLK is the SYSCLK source (ie. SYSCLK\_SRC = 0), and AIF1CLK\_ENA = 1, then an active clock source for AIF1CLK must be present for control interface clocking. If the AIF1CLK source is stopped, then AIF1CLK\_ENA must be set to 0 for control register access.

When AIF2CLK is the SYSCLK source (ie. SYSCLK\_SRC = 1), and AIF2CLK\_ENA = 1, then an active clock source for AIF2CLK must be present for control interface clocking. If the AIF2CLK source is stopped, then AIF2CLK\_ENA must be set to 0 for control register access.

### FREQUENCY LOCKED LOOP (FLL)

Two integrated FLLs are provided to support the clocking requirements of the WM1811A. These can be enabled and configured independently according to the available reference clocks and the application requirements. The reference clock may be a high frequency (eg. 12.288MHz) or low frequency (eg. 32.768kHz).

The FLL is tolerant of jitter and may be used to generate a stable AIF clock from a less stable input reference. The FLL characteristics are summarised in “Electrical Characteristics”. Note that the FLL can be used to generate a free-running clock in the absence of an external reference source. This is described in the “Free-Running FLL Clock” section below.

The input reference for FLL1 is selected using FLL1\_REFCLK\_SRC. The available options are MCLK1, MCLK2, BCLK1 or LRCLK1. The input reference for FLL2 is selected using FLL2\_REFCLK\_SRC. The available options are MCLK1, MCLK2, BCLK2 or LRCLK2.

The FLLs can be bypassed using the FLL1\_BYP or FLL2\_BYP registers. This allows the BCLK $n$  clock to be used as the AIF $n$ CLK reference, without enabling the respective FLL.

The FLL input reference and bypass configurations are illustrated in Figure 70.

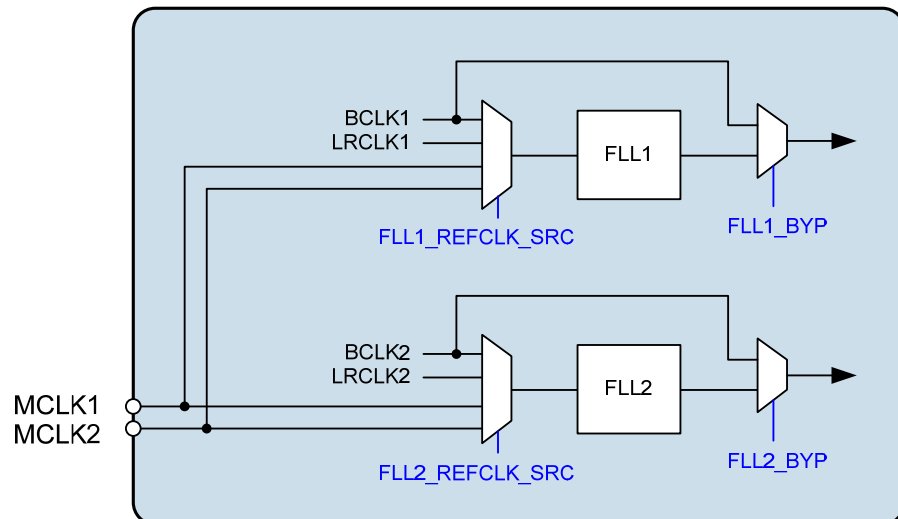

Figure 70 FLL Input Reference Selection

The following description is applicable to FLL1 and FLL2. The associated register control fields are described in Table 115 for FLL1 and Table 116 for FLL2.

The FLL control registers are illustrated in Figure 71.

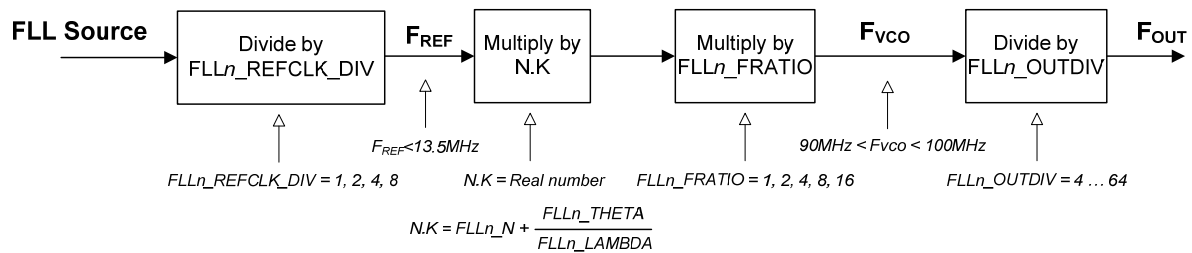

Figure 71 FLL Configuration

The FLL is enabled using the  $FLLn\_ENA$  register bit (where  $n = 1$  for FLL1 and  $n = 2$  for FLL2). Note that the other FLL registers should be configured before enabling the FLL; the  $FLLn\_ENA$  register bit should be set as the final step of the  $FLLn$  enable sequence.

When changing FLL settings, it is recommended that the digital circuit be disabled via  $FLLn\_ENA$  and then re-enabled after the other register settings have been updated. When changing the input reference frequency  $F_{REF}$ , it is recommended that the FLL be reset by setting  $FLLn\_ENA$  to 0.

The field  $FLLn\_REFCLK\_DIV$  provides the option to divide the input reference (MCLK, BCLK or LRCLK) by 1, 2, 4 or 8. This field should be set to bring the reference down to 13.5MHz or below. For best performance, it is recommended that the highest possible frequency - within the 13.5MHz limit - should be selected.

The FLL output frequency is directly determined from  $FLLn\_FRATIO$ ,  $FLLn\_OUTDIV$  and the real number represented by N.K.

The integer value, N, is held in the  $FLLn\_N$  register field. The fractional portion, K, is determined by the ratio  $FLLn\_THETA / FLLn\_LAMBDA$ .

Note that the  $FLLn\_EFS\_ENA$  register bit must be enabled in fractional mode (ie. whenever  $FLLn\_THETA > 0$ ).

The FLL output frequency is generated according to the following equation:

$$F_{OUT} = (F_{VCO} / FLLn\_OUTDIV)$$

The FLL operating frequency,  $F_{VCO}$  is set according to the following equation:

$$F_{VCO} = (F_{REF} \times N.K \times FLLn\_FRATIO)$$

$F_{REF}$  is the input frequency, as determined by  $FLLn\_REFCLK\_DIV$ .

$F_{VCO}$  must be in the range 90-100 MHz. Frequencies outside this range cannot be supported.

Note that the output frequencies that do not lie within the ranges quoted above cannot be guaranteed across the full range of device operating conditions.

In order to follow the above requirements for  $F_{VCO}$ , the value of  $FLLn\_OUTDIV$  should be selected according to the desired output  $F_{OUT}$ . The divider,  $FLLn\_OUTDIV$ , must be set so that  $F_{VCO}$  is in the range 90-100MHz. The available divisions are integers from 4 to 64. Some typical settings of  $FLLn\_OUTDIV$  are noted in Table 113.

OUTPUT FREQUENCY $F_{OUT}$	$FLLn\_OUTDIV$
1.875 MHz - 2.0833 MHz	101111 (divide by 48)
2.8125 MHz - 3.125 MHz	011111 (divide by 32)
3.75 MHz - 4.1667 MHz	010111 (divide by 24)
5.625 MHz - 6.25 MHz	001111 (divide by 16)
11.25 MHz - 12.5 MHz	000111 (divide by 8)
18 MHz - 20 MHz	000100 (divide by 5)
22.5 MHz - 25 MHz	000011 (divide by 4)

**Table 113 Selection of  $FLLn\_OUTDIV$**

The value of  $FLLn\_FRATIO$  should be selected as described in Table 114.

REFERENCE FREQUENCY $F_{REF}$	$FLLn\_FRATIO$
1MHz - 13.5MHz	0h (divide by 1)
256kHz - 1MHz	1h (divide by 2)
128kHz - 256kHz	2h (divide by 4)
64kHz - 128kHz	3h (divide by 8)
Less than 64kHz	4h (divide by 16)

**Table 114 Selection of  $FLLn\_FRATIO$**

In order to determine the remaining FLL parameters, the FLL operating frequency,  $F_{VCO}$ , must be calculated, as given by the following equation:

$$F_{VCO} = (F_{OUT} \times FLLn\_OUTDIV)$$

The value of N.K can then be determined as follows:

$$N.K = F_{VCO} / (FLLn\_FRATIO \times F_{REF})$$

Note that, in the above equations:

$FLLn\_OUTDIV$  is the  $F_{OUT}$  clock ratio.

$F_{REF}$  is the input frequency, after division by  $FLL\_REFCLK\_DIV$ , where applicable.

$FLLn\_FRATIO$  is the  $F_{VCO}$  clock ratio (1, 2, 4, 8 or 16).

The value of N is held in the  $FLLn\_N$  register field.

The value of K is determined by the ratio  $FLLn\_THETA / FLLn\_LAMBDA$ .

The  $FLLn\_N$ ,  $FLLn\_THETA$  and  $FLLn\_LAMBDA$  fields are all coded as integers (LSB = 1).



In Fractional Mode ( $FLLn\_THETA > 0$  and  $FLLn\_EFS\_ENA = 1$ ), the register fields  $FLLn\_THETA$  and  $FLLn\_LAMBDA$  can be calculated as follows:

Calculate  $GCD(FLL)$  using the 'Greatest Common Denominator' function:

$$GCD(FLL) = GCD(FLLn\_FRATIO \times F_{REF}, F_{VCO})$$

where  $GCD(x, y)$  is the greatest common denominator of  $x$  and  $y$

Next, calculate  $FLLn\_THETA$  and  $FLLn\_LAMBDA$  using the following equations:

$$FLLn\_THETA = (F_{VCO} - (FLLn\_N \times FLLn\_FRATIO \times F_{REF})) / GCD(FLL)$$

$$FLLn\_LAMBDA = (FLLn\_FRATIO \times F_{REF}) / GCD(FLL)$$

Note that, in Fractional Mode, the values of  $FLLn\_THETA$  and  $FLLn\_LAMBDA$  must be co-prime (ie. not divisible by any common integer). The calculation above ensures that the values will be co-prime.

The value of  $K$  must be a fraction less than 1 (ie.  $FLLn\_THETA$  must be less than  $FLLn\_LAMBDA$ ).

The FLL1 control registers are described in Table 115. The FLL2 control registers are described in Table 116. Example settings for a variety of reference frequencies and output frequencies are shown in Table 118.

REGISTER ADDRESS	BIT	LABEL	DEFAULT	DESCRIPTION
R544 (0220h) FLL1 Control (1)	0	FLL1_ENA	0	FLL1 Enable 0 = Disabled 1 = Enabled  This should be set as the final step of the FLL1 enable sequence, ie. after the other FLL registers have been configured.
R545 (0221h) FLL1 Control (2)	13:8	FLL1_OUTDIV [5:0]	000000	FLL1 $F_{OUT}$ clock divider 000000 = Reserved 000001 = Reserved 000010 = Reserved 000011 = 4 000100 = 5 000101 = 6 ... 111110 = 63 111111 = 64 ( $F_{OUT} = F_{VCO} / FLL1\_OUTDIV$ )
	2:0	FLL1_FRATIO [2:0]	000	FLL1 $F_{VCO}$ clock divider 000 = 1 001 = 2 010 = 4 011 = 8 1XX = 16
R546 (0222h) FLL1 Control (3)	15:0	FLL1_THETA[15:0]	0000h	FLL Fractional multiply for $F_{REF}$ This field sets the numerator (multiply) part of the $FLL1\_THETA / FLL1\_LAMBDA$ ratio. Coded as LSB = 1.
R547 (0223h) FLL1 Control (4)	14:5	FLL1_N[9:0]	000h	FLL Integer multiply for $F_{REF}$ (LSB = 1)

REGISTER ADDRESS	BIT	LABEL	DEFAULT	DESCRIPTION
R548 (0224h) FLL1 Control (5)	15	FLL1_BYP	0	FLL1 Bypass Select 0 = Disabled 1 = Enabled  When FLL1_BYP is set, the FLL1 output is derived directly from BCLK1. In this case, FLL1 can be disabled.
	4:3	FLL1_REFCLK_DIV [1:0]	00	FLL1 Clock Reference Divider 00 = MCLK / 1 01 = MCLK / 2 10 = MCLK / 4 11 = MCLK / 8  MCLK (or other input reference) must be divided down to <=13.5MHz. For lower power operation, the reference clock can be divided down further if desired.
	1:0	FLL1_REFCLK_SRC [1:0]	00	FLL1 Clock source 00 = MCLK1 01 = MCLK2 10 = LRCLK1 11 = BCLK1
R550 (0226h) FLL1 EFS1	15:0	FLL1_LAMBDA [15:0]	0000h	FLL Fractional multiply for $F_{REF}$ This field sets the denominator (dividing) part of the FLL1_THETA / FLL1_LAMBDA ratio. Coded as LSB = 1.
R551 (0227h) FLL1 EFS2	2:1		11	Reserved - Do not change
	0	FLL1_EFS_ENA	0	FLL Fractional Mode EFS enable 0 = Integer Mode 1 = Fractional Mode This bit should be set to 1 when FLL1_THETA > 0.

Table 115 FLL1 Register Map

REGISTER ADDRESS	BIT	LABEL	DEFAULT	DESCRIPTION
R576 (0240h) FLL2 Control (1)	0	FLL2_ENA	0	FLL2 Enable 0 = Disabled 1 = Enabled  This should be set as the final step of the FLL2 enable sequence, ie. after the other FLL registers have been configured.
R577 (0241h) FLL2 Control (2)	13:8	FLL2_OUTDIV [5:0]	000000	FLL2 $F_{OUT}$ clock divider 000000 = Reserved 000001 = Reserved 000010 = Reserved 000011 = 4 000100 = 5 000101 = 6 ... 111110 = 63 111111 = 64 ( $F_{OUT} = F_{VCO} / FLL2\_OUTDIV$ )
	2:0	FLL2_FRATIO [2:0]	000	FLL2 $F_{VCO}$ clock divider 000 = 1 001 = 2 010 = 4 011 = 8 1XX = 16
R578 (0242h) FLL2 Control (3)	15:0	FLL2_THETA[15:0]	0000h	FLL Fractional multiply for $F_{REF}$ This field sets the numerator (multiply) part of the FLL2_THETA / FLL2_LAMBDA ratio. Coded as LSB = 1.
R579 (0243h) FLL2 Control (4)	14:5	FLL2_N[9:0]	000h	FLL Integer multiply for $F_{REF}$ (LSB = 1)
R580 (0244h) FLL2 Control (5)	15	FLL2_BYP	0	FLL2 Bypass Select 0 = Disabled 1 = Enabled  When FLL2_BYP is set, the FLL2 output is derived directly from BCLK2. In this case, FLL2 can be disabled.
	4:3	FLL2_REFCLK_DIV [1:0]	00	FLL2 Clock Reference Divider 00 = MCLK / 1 01 = MCLK / 2 10 = MCLK / 4 11 = MCLK / 8  MCLK (or other input reference) must be divided down to $\leq 13.5$ MHz. For lower power operation, the reference clock can be divided down further if desired.
	1:0	FLL2_REFCLK_SRC [1:0]	00	FLL2 Clock source 00 = MCLK1 01 = MCLK2 10 = LRCLK2 11 = BCLK2

REGISTER ADDRESS	BIT	LABEL	DEFAULT	DESCRIPTION
R582 (0246h) FLL2 EFS1	15:0	FLL2_LAMBDA [15:0]	0000h	FLL Fractional multiply for $F_{REF}$ This field sets the denominator (dividing) part of the FLL2_THETA / FLL2_LAMBDA ratio. Coded as LSB = 1.
R583 (0247h) FLL2 EFS2	2:1		11	Reserved - Do not change
	0	FLL2_EFS_ENA	0	FLL Fractional Mode EFS enable 0 = Integer Mode 1 = Fractional Mode This bit should be set to 1 when FLL2_THETA > 0.

Table 116 FLL2 Register Map

### FREE-RUNNING FLL CLOCK

The FLL can generate a clock signal even when no external reference is available. However, it should be noted that the accuracy of this clock is reduced, and a reference source should always be used where possible. The free-running FLL modes are not sufficiently accurate for hi-fi ADC or DAC operations, but are suitable for clocking most other functions, including the Charge Pump, DC Servo and Class D loudspeaker driver. The free-running FLL operation is ideal for clocking the accessory detection function during low-power standby operating conditions (see "External Accessory Detection").

If an accurate reference clock is initially available, then the FLL should be configured as described above. The FLL will continue to generate a stable output clock after the reference input is stopped or disconnected.

If no reference clock is available at the time of starting up the FLL, then an internal clock frequency of approximately 12MHz can be generated by implementing the following sequence:

- Enable the FLL Analogue Oscillator (FLLn\_OSC\_ENA = 1)
- Set the  $F_{OUT}$  clock divider to divide by 8 (FLLn\_OUTDIV = 000111)
- Configure the oscillator frequency by setting FLLn\_FRC\_NCO = 1 and FLLn\_FRC\_NCO\_VAL = 19h

Note that the free-running FLL mode is not suitable for hi-fi CODEC applications. In the absence of any reference clock, the FLL output is subject to a very wide tolerance; see "Electrical Characteristics" for details of the FLL accuracy.

Note that the free-running FLL clock is selected as SYSCLK using the registers noted in Figure 67.

The free-running FLL clock may be used to support analogue functions, for which the digital audio interface is not used, and there is no applicable Sample Rate (fs). When SYSCLK is required for circuits such as the Class D, DC Servo or Charge Pump, then valid Sample Rate register settings are still required, even though the digital audio interface is not active.

For correct functionality when SYSCLK\_SRC = 0, valid settings are required for AIF1\_SR and AIF1CLK\_RATE. In the case where SYSCLK\_SRC = 1, then valid settings are required for AIF2\_SR and AIF2CLK\_RATE.

The control registers applicable to FLL free-running modes are described in Table 117.

REGISTER ADDRESS	BIT	LABEL	DEFAULT	DESCRIPTION
R544 (0220h) FLL1 Control (1)	1	FLL1_OSC_ENA	0	FLL1 Oscillator enable 0 = Disabled 1 = Enabled (Note that this field is required for free-running FLL1 modes only)
R548 (0224h) FLL1 Control (5)	12:7	FLL1_FRC_NCO_VAL [5:0]	19h	FLL1 Forced oscillator value Valid range is 000000 to 111111 0x19h (011001) = 12MHz approx (Note that this field is required for free-running FLL modes only)
	6	FLL1_FRC_NCO	0	FLL1 Forced control select 0 = Normal 1 = FLL1 oscillator controlled by FLL1_FRC_NCO_VAL (Note that this field is required for free-running FLL modes only)
R576 (0240h) FLL2 Control (1)	1	FLL2_OSC_ENA	0	FLL2 Oscillator enable 0 = Disabled 1 = Enabled (Note that this field is required for free-running FLL2 modes only)
R580 (0244h) FLL2 Control (5)	12:7	FLL2_FRC_NCO_VAL [5:0]	19h	FLL2 Forced oscillator value Valid range is 000000 to 111111 0x19h (011001) = 12MHz approx (Note that this field is required for free-running FLL modes only)
	6	FLL2_FRC_NCO	0	FLL2 Forced control select 0 = Normal 1 = FLL2 oscillator controlled by FLL2_FRC_NCO_VAL (Note that this field is required for free-running FLL modes only)

Table 117 FLL Free-Running Mode

### GPIO OUTPUTS FROM FLL

For each FLL, the WM1811A has an internal signal which indicates whether the FLL Lock has been achieved. The FLL Lock status is an input to the Interrupt control circuit and can be used to trigger an Interrupt event - see "Interrupts".

The FLL Lock signal can be output directly on a GPIO pin as an external indication of FLL Lock. See "General Purpose Input/Output" for details of how to configure a GPIO pin to output the FLL Lock signal.

The FLL Clock can be output directly on a GPIO pin as a clock signal for other circuits. Note that the FLL Clock may be output even if the FLL is not selected as the WM1811A SYCLK source. The FLL clocking configuration is illustrated in Figure 70. See "General Purpose Input/Output" for details of how to configure a GPIO pin to output the FLL Clock.

**EXAMPLE FLL CALCULATION**

The following example illustrates how to derive the FLL1 registers to generate 12.288 MHz output ( $F_{OUT}$ ) from a 12.000 MHz reference clock ( $F_{REF}$ ):

- Set FLL1\_REFCLK\_DIV in order to generate  $F_{REF} \leq 13.5\text{MHz}$ :  
FLL1\_REFCLK\_DIV = 00 (divide by 1)
- Set FLL1\_OUTDIV for the required output frequency as shown in Table 113:-  
 $F_{OUT} = 12.288\text{ MHz}$ , therefore FLL1\_OUTDIV = 7h (divide by 8)
- Set FLL1\_FRATIO for the given reference frequency as shown in Table 114:  
 $F_{REF} = 12\text{MHz}$ , therefore FLL1\_FRATIO = 0h (divide by 1)
- Calculate  $F_{VCO}$  as given by  $F_{VCO} = F_{OUT} \times FLL1\_OUTDIV$ :-  
 $F_{VCO} = 12.288 \times 8 = 98.304\text{MHz}$
- Calculate N.K as given by  $N.K = F_{VCO} / (FLL1\_FRATIO \times F_{REF})$ :  
 $N.K = 98.304 / (1 \times 12) = 8.192$
- Set FLL1\_EFS\_ENA according to whether N.K is an integer.  
N.K has a fractional part, therefore FLL1\_EFS\_ENA = 1
- Determine FLL1\_N from the integer portion of N.K:-  
FLL1\_N = 8.
- Determine GCD(FLL), as given by  $GCD(FLL) = GCD(FLL1\_FRATIO \times F_{REF}, F_{VCO})$ :  
 $GCD(FLL) = GCD(1 \times 12000000, 98304000) = 96000$
- Determine FLL1\_THETA, as given by  
 $FLL1\_THETA = (F_{VCO} - (FLL1\_N \times FLL1\_FRATIO \times F_{REF})) / GCD(FLL)$ :  
 $FLL1\_THETA = (98304000 - (8 \times 1 \times 12000000)) / 96000$   
FLL1\_THETA = 24 (0018h)
- Determine FLL\_LAMBDA, as given by  
 $FLL1\_LAMBDA = (FLL1\_FRATIO \times F_{REF}) / GCD(FLL)$ :  
 $FLL1\_LAMBDA = (1 \times 12000000) / 96000$   
FLL1\_LAMBDA = 125 (007Dh)

## EXAMPLE FLL SETTINGS

Table 118 provides example FLL settings for generating common SYSCLK frequencies from a variety of low and high frequency reference inputs.

F <sub>SOURCE</sub>	F <sub>OUT</sub> (MHz)	F <sub>REF</sub> Divider	N.K	FRATIO	F <sub>VCO</sub> (MHz)	OUTDIV	FLLn_N	FLLn_ EFS_EN A	FLLn_ THETA	FLLn_ LAMBDA
32.000kHz	12.288	1	192	16	98.304	8	0C0h	0		
32.000kHz	11.2896	1	176.4	16	90.3168	8	0B0h	1	0002h	0005h
32.768kHz	12.288	1	187.5	16	98.304	8	0BBh	1	0001h	0002h
32.768kHz	11.2896	1	172.2656	16	90.3168	8	0ACh	1	0011h	0040h
44.1 kHz	11.2896	1	128	16	90.3168	8	080h	0		
48 kHz	12.288	1	128	16	98.304	8	080h	0		
128 kHz	2.048	1	96	8	98.304	48	060h	0		
128 kHz	12.288	1	96	8	98.304	8	060h	0		
512 kHz	2.048	1	96	2	98.304	48	060h	0		
512 kHz	12.288	1	96	2	98.304	8	060h	0		
1.4112 MHz	11.2896	1	64	1	90.3168	8	040h	0		
2.8224 MHz	11.2896	1	32	1	90.3168	8	020h	0		
1.536 MHz	12.288	1	64	1	98.304	8	040h	0		
3.072 MHz	12.288	1	32	1	98.304	8	020h	0		
11.2896	12.288	1	8.7075	1	98.304	8	008h	1	0068h	0093h
12.000MHz	12.288	1	8.192	1	98.304	8	008h	1	0018h	007Dh
12.000MHz	11.2896	1	7.5264	1	90.3168	8	007h	1	0149h	0271h
12.288MHz	12.288	1	8	1	98.304	8	008h	0		
12.288MHz	11.2896	1	7.35	1	90.3168	8	007h	1	0007h	0014h
13.000MHz	12.288	1	7.5618	1	98.304	8	007h	1	0391h	0659h
13.000MHz	11.2896	1	6.9474	1	90.3168	8	006h	1	1E12h	1FBDh
19.200MHz	12.288	2	10.24	1	98.304	8	00Ah	1	0006h	0019h
19.200MHz	11.2896	2	9.408	1	90.3168	8	009h	1	0033h	007Dh
24 MHz	12.288	2	8.192	1	98.304	8	008h	1	0018h	007Dh
24 MHz	11.2896	2	7.5264	1	90.3168	8	007h	1	0149h	0271h
26 MHz	12.288	2	7.5618	1	98.304	8	007h	1	0391h	0659h
26 MHz	11.2896	2	6.9474	1	90.3168	8	006h	1	1E12h	1FBDh
27 MHz	12.288	2	7.2818	1	98.304	8	007h	1	013Dh	0465h
27 MHz	11.2896	2	6.6901	1	90.3168	8	006h	1	050Eh	0753h

$F_{OUT} = (F_{SOURCE} / F_{REF} \text{ Divider}) * N.K * FRATIO / OUTDIV$   
 The values of N and K are contained in the FLLn\_N, FLLn\_THETA and FLLn\_LAMBDA registers as shown above.  
 See Table 115 and Table 116 for the coding of the FLLn\_REFCLK\_DIV, FLLn\_FRATIO and FLLn\_OUTDIV registers.

Table 118 Example FLL Settings

## SAMPLE RATE CONVERSION

The WM1811A supports two main digital audio interfaces, AIF1 and AIF2. These interfaces are configured independently and may operate entirely asynchronously to each other. The WM1811A performs stereo full-duplex sample rate conversion between the audio interfaces, allowing digital audio to be routed between the interfaces, and allowing asynchronous audio data to be mixed together.

The Sample Rate Converters (SRCs) are configured automatically within the WM1811A, and no user settings are required. The SRCs are enabled automatically when required and are disabled at other times. Synchronisation between the audio interfaces is not instantaneous when the clocking or sample rate configurations are updated; the lock status of the SRCs is signalled via the GPIO or Interrupt circuits, as described in “General Purpose Input/Output” and “Interrupts”.

Separate clocks can be used for AIF1 and AIF2, allowing asynchronous operation on these interfaces. The digital mixing core is clocked by SYSCCLK, which is linked to either AIF1CLK or AIF2CLK, as described in “Clocking and Sample Rates”. The digital mixing core is, therefore, always synchronised to AIF1, or to AIF2, or to both interfaces at once.

### SAMPLE RATE CONVERTER 1 (SRC1)

SRC1 performs sample rate conversion of digital audio data input to the WM1811A. Sample Rate Conversion is required when digital audio data is received on an audio interface that is not synchronised to the digital mixing core.

SRC1 is automatically configured on AIF1 or AIF2, depending on the selected Clocking and Sample Rate configuration. Note that SRC1 cannot convert input data on AIF1 and AIF2 simultaneously.

The SRC1 Lock status indicates when audio data can be received on the interface channel that is not synchronised to the digital mixing core. No audio will be present on this signal path until SRC1 Lock is achieved.

### SAMPLE RATE CONVERTER 2 (SRC2)

SRC2 performs sample rate conversion of digital audio data output from the WM1811A. Sample Rate Conversion is required when digital audio data is transmitted on an audio interface that is not synchronised to the digital mixing core.

SRC2 is automatically configured on AIF1 or AIF2, depending on the selected Clocking and Sample Rate configuration. Note that SRC2 cannot convert output data on AIF1 and AIF2 simultaneously.

The SRC2 Lock status indicates when audio data can be transmitted on the interface channel that is not synchronised to the digital mixing core. No audio will be present on this signal path until SRC2 Lock is achieved.



### SAMPLE RATE CONVERTER RESTRICTIONS

The following restrictions apply to the configuration of the WM1811A Sample Rate Converters.

**No SRC capability when using 88.2kHz or 96kHz AIF input (DAC playback).** If either interface is configured for 88.2kHz or 96kHz sample rate, then the digital mixing core must also be configured for this sample rate. Sample Rate Conversion cannot be supported in this mode, therefore AIF output is not supported at any sample rate under these conditions.

**Restricted Sample Rate options when AIF1 and AIF2 are not synchronised.** When a different clock source is used for AIF1CLK and AIF2CLK, then the AIF to which the SYSCLK is synchronised cannot be mixed sample rates.

- If AIF1CLK\_SRC ≠ AIF2CLK\_SRC
- And SYSCLK\_SRC =0
- Then AIF1DAC\_DIV and AIF1ADC\_DIV must be set to 000

### SAMPLE RATE CONVERTER CONFIGURATION ERROR INDICATION

The WM1811A verifies the register settings relating to Clocking, Sample Rates and Sample Rate Conversion. If an invalid configuration is attempted, then the SR\_ERROR register will indicate the error by showing a non-zero value. This read-only field may be checked to confirm that the WM1811A can support the selected Clocking and Sample Rate settings.

REGISTER ADDRESS	BIT	LABEL	DEFAULT	DESCRIPTION
R530 (0212h) Rate Status	3:0	SR_ERROR [3:0]	0000	Sample Rate Configuration status Indicates an error with the register settings related to sample rate configuration 0000 = No errors 0001 = Invalid sample rate 0010 = Invalid AIF divide 0011 = ADC and DAC divides both set in an interface 0100 = Invalid combination of AIF divides and sample-rate 0101 = Invalid set of enables for 96kHz mode 0110 = Invalid SYSCLK rate (derived from AIF1CLK_RATE or AIF2CLK_RATE) 0111 = Mixed ADC and DAC rates in SYSCLK AIF when AIFs are asynchronous 1000 = Invalid combination of sample rates when both AIFs are from the same clock source 1001 = Invalid combination of mixed ADC/DAC AIFs when both from the same clock source

Table 119 Sample Rate Converter Configuration Status

## CONTROL INTERFACE

The WM1811A is controlled by writing to registers through a 2-wire serial control interface. Readback is available for all registers, including Chip ID and power management status.

Note that the Control Interface function can be supported with or without system clocking. Where possible, the register map access is synchronised with SYSCLK in order to ensure predictable operation of cross-domain functions. See “Clocking and Sample Rates” for further details of Control Interface clocking.

The WM1811A is a slave device on the control interface; SCLK is a clock input, while SDAT is a bi-directional data pin. To allow arbitration of multiple slaves (and/or multiple masters) on the same interface, the WM1811A transmits logic 1 by tri-stating the SDAT pin, rather than pulling it high. An external pull-up resistor is required to pull the SDAT line high so that the logic 1 can be recognised by the master.

In order to allow many devices to share a single 2-wire control bus, every device on the bus has a unique 8-bit device ID (this is not the same as the address of each register in the WM1811A). The device ID is selectable on the WM1811A, using the ADDR pin as shown in Table 120. The LSB of the Device ID is the Read/Write bit; this bit is set to logic 1 for “Read” and logic 0 for “Write”.

An internal pull-down resistor is enabled by default on the ADDR pin; this can be configured using the ADDR\_PD register bit described in Table 122.

ADDR	DEVICE ID
Low	0011 0100 (34h)
High	0011 0110 (36h)

**Table 120 Control Interface Device ID Selection**

The WM1811A operates as a slave device only. The controller indicates the start of data transfer with a high to low transition on SDAT while SCLK remains high. This indicates that a device ID, register address and data will follow. The WM1811A responds to the start condition and shifts in the next eight bits on SDAT (8-bit device ID, including Read/Write bit, MSB first). If the device ID received matches the device ID of the WM1811A, then the WM1811A responds by pulling SDAT low on the next clock pulse (ACK). If the device ID is not recognised or the R/W bit is set incorrectly, the WM1811A returns to the idle condition and waits for a new start condition and valid address.

If the device ID matches the device ID of the WM1811A, the data transfer continues as described below. The controller indicates the end of data transfer with a low to high transition on SDAT while SCLK remains high. After receiving a complete address and data sequence the WM1811A returns to the idle state and waits for another start condition. If a start or stop condition is detected out of sequence at any point during data transfer (i.e. SDAT changes while SCLK is high), the device returns to the idle condition.

The WM1811A supports the following read and write operations:

- Single write
- Single read
- Multiple write using auto-increment
- Multiple read using auto-increment

The sequence of signals associated with a single register write operation is illustrated in Figure 72.

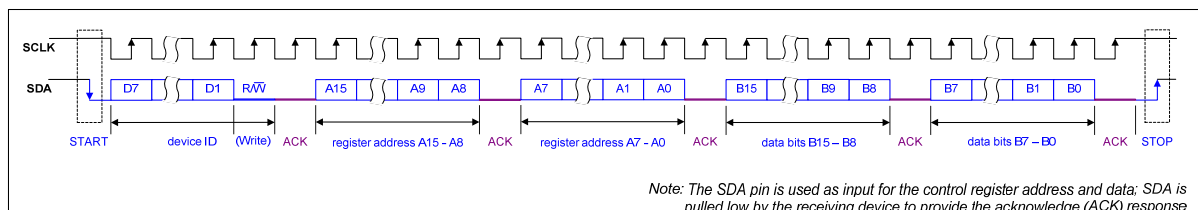

**Figure 72 Control Interface 2-wire (I2C) Register Write**

The sequence of signals associated with a single register read operation is illustrated in Figure 73.

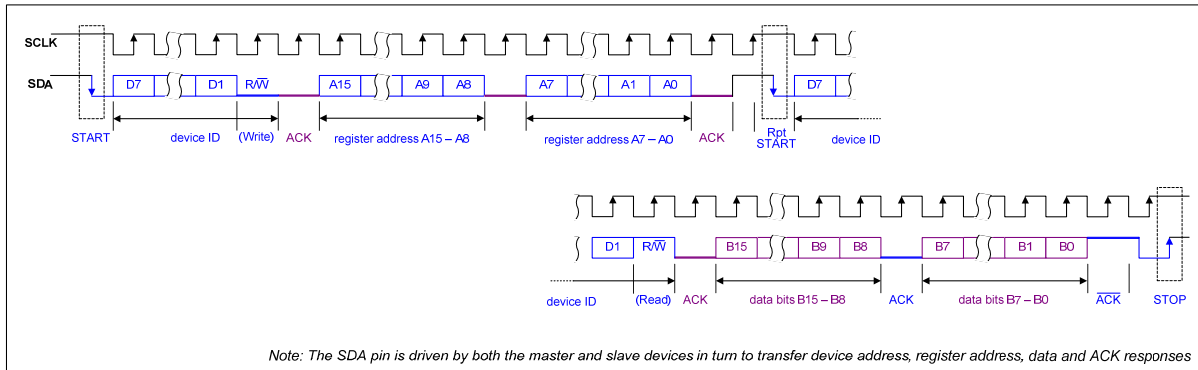

Figure 73 Control Interface 2-wire (I2C) Register Read

The Control Interface also supports other register operations, as listed above. The interface protocol for these operations is summarised below. The terminology used in the following figures is detailed in Table 121.

Note that, for multiple write and multiple read operations, the auto-increment option must be enabled. This feature is enabled by default, as noted in Table 122.

TERMINOLOGY	DESCRIPTION	
S	Start Condition	
Sr	Repeated start	
A	Acknowledge (SDA Low)	
$\bar{A}$	Not Acknowledge (SDA High)	
P	Stop Condition	
R/ $\bar{W}$	ReadNotWrite	0 = Write 1 = Read
[White field]	Data flow from bus master to WM1811A	
[Grey field]	Data flow from WM1811A to bus master	

Table 121 Control Interface Terminology

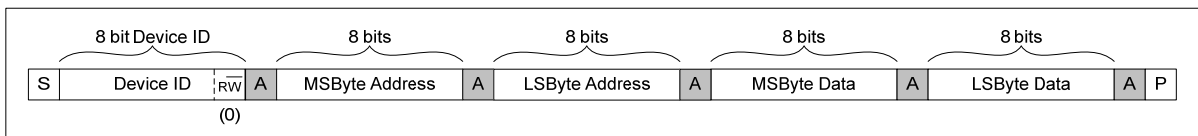

Figure 74 Single Register Write to Specified Address

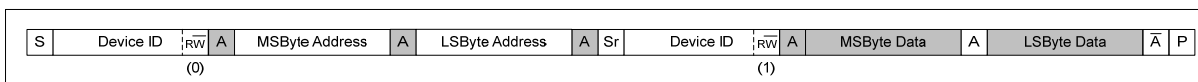

Figure 75 Single Register Read from Specified Address

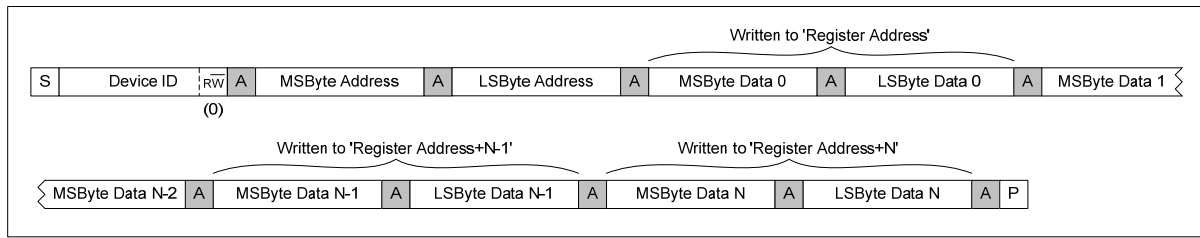

Figure 76 Multiple Register Write to Specified Address using Auto-increment

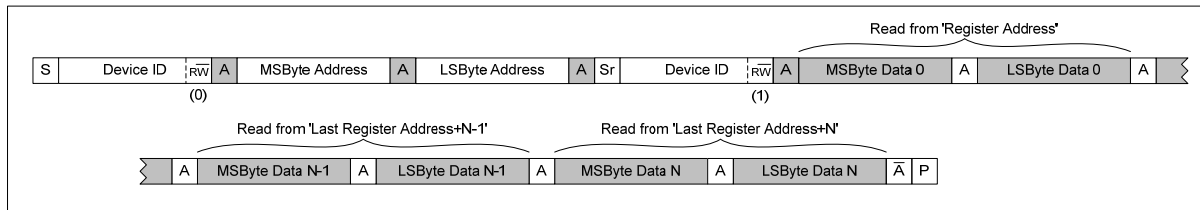

Figure 77 Multiple Register Read from Specified Address using Auto-increment

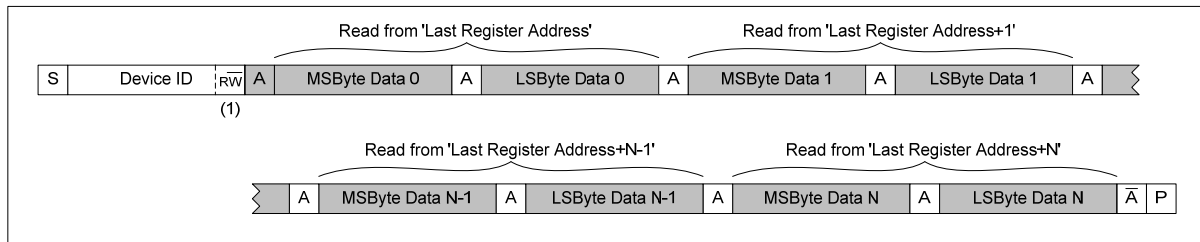

Figure 78 Multiple Register Read from Last Address using Auto-increment

Multiple Write and Multiple Read operations enable the host processor to access sequential blocks of the data in the WM1811A register map faster than is possible with single register operations. The auto-increment option is enabled when the AUTO\_INC register bit is set. This bit is defined in Table 122. Auto-increment is enabled by default.

REGISTER ADDRESS	BIT	LABEL	DEFAULT	DESCRIPTION
R257 (0101h) Control Interface	2	AUTO_INC	1	Enables address auto-increment 0 = Disabled 1 = Enabled
R1825 (0721h) Pull Control (2)	8	ADDR_PD	1	ADDR Pull-down enable 0 = Disabled 1 = Enabled

Table 122 Control Interface Configuration

## POP SUPPRESSION CONTROL

The WM1811A incorporates a number of features, including Wolfson's SilentSwitch™ technology, designed to suppress pops normally associated with Start-Up, Shut-Down or signal path control. Note that, to achieve maximum benefit from these features, careful attention is required to the sequence and timing of these controls.

The Pop Suppression controls relating to the Headphone / Line Output drivers are described in the "Analogue Output Signal Path" section.

Additional bias controls are described in the "Reference Voltages and Master Bias" section.

### DISABLED LINE OUTPUT CONTROL

The line outputs are biased to VMID in normal operation. To avoid audible pops caused by a disabled signal path dropping to AGND, the WM1811A can maintain these connections at VMID when the relevant output stage is disabled. This is achieved by connecting a buffered VMID reference to the output.

The buffered VMID reference is enabled by setting VMID\_BUF\_ENA. The output resistance is selectable, using the VROI register bit.

Note that, if LINEOUTn\_DISCH=1 (see Table 124), then the respective output will be discharged to AGND, and will not be connected to VMID.

REGISTER ADDRESS	BIT	LABEL	DEFAULT	DESCRIPTION
R55 (0037h) Additional Control	0	VROI	0	Buffered VMID to Analogue Line Output Resistance (Disabled Outputs) 0 = 20kΩ from buffered VMID to output 1 = 500Ω from buffered VMID to output
R57 (0039h) AntiPOP (2)	3	VMID_BUF_ENA	0	VMID Buffer Enable 0 = Disabled 1 = Enabled (provided VMID_SEL > 00)

**Table 123 Disabled Line Output Control**

### LINE OUTPUT DISCHARGE CONTROL

The line output paths can be actively discharged to AGND through internal resistors if desired. This is desirable at start-up in order to achieve a known output stage condition prior to enabling the soft-start VMID reference voltage. This is also desirable in shut-down to prevent the external connections from being affected by the internal circuits.

The line outputs LINEOUT1P and LINEOUT1N are discharged to AGND by setting LINEOUT1\_DISCH. The line outputs LINEOUT2P and LINEOUT2N are discharged to AGND by setting LINEOUT2\_DISCH.

The discharge resistance is dependent upon the respective LINEOUTn\_ENA bit, and also according to the VROI bit (see Table 123). The discharge resistance is noted in the "Electrical Characteristics" section.

REGISTER ADDRESS	BIT	LABEL	DEFAULT	DESCRIPTION
R56 (0038h) AntiPOP (1)	5	LINEOUT1_DISCH	0	Discharges LINEOUT1P and LINEOUT1N outputs 0 = Not active 1 = Actively discharging LINEOUT1P and LINEOUT1N
	4	LINEOUT2_DISCH	0	Discharges LINEOUT2P and LINEOUT2N outputs 0 = Not active 1 = Actively discharging LINEOUT2P and LINEOUT2N

Table 124 Line Output Discharge Control

### VMID REFERENCE DISCHARGE CONTROL

The VMID reference can be actively discharged to AGND through internal resistors. This is desirable at start-up in order to achieve a known initial condition prior to enabling the soft-start VMID reference; this ensures maximum suppression of audible pops associated with start-up. VMID is discharged by setting VMID\_DISCH.

REGISTER ADDRESS	BIT	LABEL	DEFAULT	DESCRIPTION
R57 (0039h) AntiPOP (2)	0	VMID_DISCH	0	Connects VMID to ground 0 = Disabled 1 = Enabled

Table 125 VMID Reference Discharge Control

### INPUT VMID CLAMPS

The analogue inputs can be clamped to Vmid using the INPUTS\_CLAMP bit described below. This allows pre-charging of the input AC coupling capacitors during power-up. Note that all eight inputs are clamped using the same control bit.

Note that INPUTS\_CLAMP must be set to 0 when the analogue input signal paths are in use.

REGISTER ADDRESS	BIT	LABEL	DEFAULT	DESCRIPTION
R21 (15h) Input Mixer (1)	6	INPUTS_CLAMP	0	Input pad VMID clamp 0 = Clamp de-activated 1 = Clamp activated

Table 126 Input VMID Clamps

## LDO REGULATORS

The WM1811A provides two integrated Low Drop-Out Regulators (LDOs). These are provided to generate the appropriate power supplies for internal circuits, simplifying and reducing the requirements for external supplies and associated components. A reference circuit powered by AVDD2 ensures the accuracy of the LDO regulator voltage settings.

Note that the integrated LDOs are only intended for generating the AVDD1 and DCVDD supply rails for the WM1811A; they are not suitable for powering any additional or external loads.

LDO1 is intended for generating AVDD1 - the primary analogue power domain of the WM1811A. LDO1 is powered by LDO1VDD and is enabled when a logic '1' is applied to the LDO1ENA pin. The logic level is determined with respect to the DBVDD1 voltage domain. The LDO1 start-up time is dependent on the external AVDD1 and VREFC capacitors; the start-up time is noted in the "Electrical Characteristics" section for the recommended external component conditions.

When LDO1 is enabled, the output voltage is controlled by the LDO1\_VSEL register field. Note that the LDO1 voltage difference LDO1VDD - AVDD1 must be higher than the LDO1 Drop-Out voltage (see "Electrical Characteristics").

When LDO1 is disabled (by applying a logic '0' to the LDO1ENA pin), the output can be left floating or can be actively discharged, depending on the LDO1\_DISCH control bit.

It is possible to supply AVDD1 from an external supply. If AVDD1 is supplied externally, then LDO1 should be disabled, and the LDO1 output left floating (LDO1DISCH = 0). Note that the LDO1VDD voltage must be greater than or equal to AVDD1; this ensures that there is no leakage path through the LDO for the external supply.

Note that the WM1811A can operate with AVDD1 tied to 0V; power consumption may be reduced, but the analogue audio functions will not be supported.

LDO2 is intended for generating the DCVDD power domain which supplies the digital core functions on the WM1811A. LDO2 is powered by DBVDD1 and is enabled when a logic '1' is applied to the LDO2ENA pin. The logic level is determined with respect to the DBVDD1 voltage domain. The LDO2 start-up time is dependent on the external DCVDD and VREFC capacitors; the start-up time is noted in the "Electrical Characteristics" section for the recommended external component conditions.

When LDO2 is enabled, the output voltage is controlled by the LDO2\_VSEL register field.

When LDO2 is disabled (by applying a logic '0' to the LDO2ENA pin), the output can be left floating or can be actively discharged, depending on the LDO2\_DISCH control bit.

It is possible to supply DCVDD from an external supply. If DCVDD is supplied externally, the LDO2ENA and LDO2DISCH bits should be set to 0. Note that the DBVDD1 voltage must be greater than or equal to DCVDD; this ensures that there is no leakage path through the LDO for the external supply.

An internal pull-down resistor is enabled by default on the LDO1ENA and LDO2ENA pins. These pull-down resistors can be configured using the register bits described in Table 127.

Decoupling capacitors should be connected to the voltage reference pin, VREFC, and also to the LDO outputs, AVDD1 and DCVDD. See "Applications Information" for further details.

The LDO Regulator connections and controls are illustrated in Figure 79. The register controls are defined in Table 127.

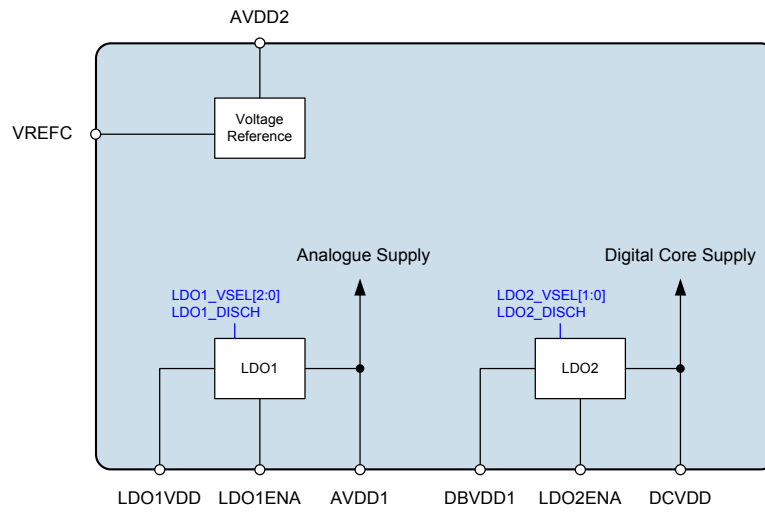

Figure 79 LDO Regulators

REGISTER ADDRESS	BIT	LABEL	DEFAULT	DESCRIPTION
R59 (003Bh) LDO 1	3:1	LDO1_VSEL [2:0]	110	LDO1 Output Voltage Select 2.4V to 3.1V in 100mV steps 000 = 2.4V 001 = 2.5V 010 = 2.6V 011 = 2.7V 100 = 2.8V 101 = 2.9V 110 = 3.0V 111 = 3.1V
	0	LDO1_DISCH	1	LDO1 Discharge Select 0 = LDO1 floating when disabled 1 = LDO1 discharged when disabled
R60 (003Ch) LDO 2	2:1	LDO2_VSEL [1:0]	01	LDO2 Output Voltage Select 1.05V to 1.25V in 100mV steps 00 = Reserved 01 = 1.05V 10 = 1.15V 11 = 1.25V
	0	LDO2_DISCH	1	LDO2 Discharge Select 0 = LDO2 floating when disabled 1 = LDO2 discharged when disabled
R1825 (0721h) Pull Control (2)	6	LDO2ENA_PD	1	LDO2ENA Pull-down enable 0 = Disabled 1 = Enabled
	4	LDO1ENA_PD	1	LDO1ENA Pull-down enable 0 = Disabled 1 = Enabled

Table 127 LDO Regulator Control



## REFERENCE VOLTAGES AND MASTER BIAS

This section describes the analogue reference voltage and bias current controls. It also describes the VMID soft-start circuit for pop suppressed start-up and shut-down.

The analogue circuits in the WM1811A require a mid-rail analogue reference voltage, VMID. This reference is generated from AVDD1 via a programmable resistor chain. Together with the external VMID decoupling capacitor, the programmable resistor chain determines the charging characteristic on VMID. This is controlled by VMID\_SEL[1:0], and can be used to optimise the reference for normal operation or low power standby as described in Table 128.

A buffered mid-rail reference voltage is provided. This is required for the single-ended configuration of the Input PGAs, and also for direct signal paths from the input pins to the Input Mixers, Output Mixers or Speaker Mixers. These requirements are noted in the relevant “Analogue Input Signal Path” and “Analogue Output Signal Path” sections. The buffered mid-rail reference is enabled by setting the VMID\_BUF\_ENA register bit.

The analogue circuits in the WM1811A require a bias current. The normal bias current is enabled by setting BIAS\_ENA. Note that the normal bias current source requires VMID to be enabled also.

REGISTER ADDRESS	BIT	LABEL	DEFAULT	DESCRIPTION
R1 (0001h) Power Management (1)	2:1	VMID_SEL [1:0]	00	VMID Divider Enable and Select 00 = VMID disabled (for OFF mode) 01 = 2 x 40kΩ divider (for normal operation) 10 = 2 x 240kΩ divider (for low power standby) 11 = Reserved
	0	BIAS_ENA	0	Enables the Normal bias current generator (for all analogue functions) 0 = Disabled 1 = Enabled
R57 (0039h) AntiPOP (2)	3	VMID_BUF_ENA	0	VMID Buffer Enable 0 = Disabled 1 = Enabled (provided VMID_SEL > 00)

**Table 128 Reference Voltages and Master Bias Enable**

A pop-suppressed start-up requires VMID to be enabled smoothly, without the step change normally associated with the initial stage of the VMID capacitor charging. A pop-suppressed start-up also requires the analogue bias current to be enabled throughout the signal path prior to the VMID reference voltage being applied. The WM1811A incorporates pop-suppression circuits which address these requirements.

An alternate bias current source (Start-Up Bias) is provided for pop-free start-up; this is enabled by the STARTUP\_BIAS\_ENA register bit. The start-up bias is selected (in place of the normal bias) using the BIAS\_SRC bit. It is recommended that the start-up bias is used during start-up, before switching back to the higher quality, normal bias.

A soft-start circuit is provided in order to control the switch-on of the VMID reference. The soft-start control circuit offers two slew rates for enabling the VMID reference; these are selected and enabled by VMID\_RAMP. When the soft-start circuit is enabled prior to enabling VMID\_SEL, the reference voltage rises smoothly, without the step change that would otherwise occur. It is recommended that the soft-start circuit and the output signal path be enabled before VMID is enabled by VMID\_SEL.

A soft shut-down is provided, using the soft-start control circuit and the start-up bias current generator. The soft shut-down of VMID is achieved by setting VMID\_RAMP, STARTUP\_BIAS\_ENA and BIAS\_SRC to select the start-up bias current and soft-start circuit prior to setting VMID\_SEL=00.

Note that, if the VMID\_RAMP function is enabled for soft start-up or soft shut-down then, after setting VMID\_SEL = 00 to disable VMID, the soft-start circuit must be reset before re-enabling VMID. The soft-start circuit is reset by setting VMID\_RAMP = 00. After resetting the soft-start circuit, the VMID\_RAMP register may be updated to the required setting for the next VMID transition.

The VMID soft-start register controls are defined in Table 129.

REGISTER ADDRESS	BIT	LABEL	DEFAULT	DESCRIPTION
R57 (0039h) AntiPOP (2)	6:5	VMID_RAMP [1:0]	10	VMID soft start enable / slew rate control 00 = Normal slow start 01 = Normal fast start 10 = Soft slow start 11 = Soft fast start If VMID_RAMP = 1X is selected for VMID start-up or shut-down, then the soft-start circuit must be reset by setting VMID_RAMP=00 after VMID is disabled, before VMID is re-enabled. VMID is disabled / enabled using the VMID_SEL register.
	2	STARTUP_BIAS_ENA	0	Enables the Start-Up bias current generator 0 = Disabled 1 = Enabled
	1	BIAS_SRC	1	Selects the bias current source 0 = Normal bias 1 = Start-Up bias

Table 129 Soft Start Control

## POWER MANAGEMENT

The WM1811A has control registers that allow users to select which functions are active. For minimum power consumption, unused functions should be disabled. To minimise pop or click noise, it is important to enable or disable functions in the correct order. See “Analogue Output Signal Path” for details of recommended output driver control sequences.

REGISTER ADDRESS	BIT	LABEL	DEFAULT	DESCRIPTION
R1 (0001h) Power Management (1)	13	SPKOUTR_ENA	0	SPKMIXR Mixer, SPKRVOL PGA and SPKOUTR Output Enable 0 = Disabled 1 = Enabled
	12	SPKOUTL_ENA	0	SPKMIXL Mixer, SPKLVOL PGA and SPKOUTL Output Enable 0 = Disabled 1 = Enabled
	11	HPOUT2_ENA	0	HPOUT2 and HPOUT2MIX Enable 0 = Disabled 1 = Enabled
	9	HPOUT1L_ENA	0	Enables HPOUT1L input stage 0 = Disabled 1 = Enabled
	8	HPOUT1R_ENA	0	Enables HPOUT1R input stage 0 = Disabled 1 = Enabled
	5	MICB2_ENA	0	Microphone Bias 2 Enable 0 = Disabled 1 = Enabled
	4	MICB1_ENA	0	Microphone Bias 1 Enable 0 = Disabled 1 = Enabled
	2:1	VMID_SEL [1:0]	00	VMID Divider Enable and Select 00 = VMID disabled (for OFF mode) 01 = 2 x 40kΩ divider (Normal mode) 10 = 2 x 240kΩ divider (Standby mode) 11 = Reserved
	0	BIAS_ENA	0	Enables the Normal bias current generator (for all analogue functions) 0 = Disabled 1 = Enabled
R2 (0002h) Power Management (2)	14	TSHUT_ENA	1	Thermal Sensor Enable 0 = Disabled 1 = Enabled
	13	TSHUT_OPDIS	1	Thermal Shutdown Control (Causes audio outputs to be disabled if an over-temperature occurs. The thermal sensor must also be enabled.) 0 = Disabled 1 = Enabled
	11	OPCLK_ENA	0	GPIO Clock Output (OPCLK) Enable 0 = Disabled 1 = Enabled
	9	MIXINL_ENA	0	Left Input Mixer Enable (Enables MIXINL and RXVOICE input to MIXINL) 0 = Disabled

REGISTER ADDRESS	BIT	LABEL	DEFAULT	DESCRIPTION
				1 = Enabled
	8	MIXINR_ENA	0	Right Input Mixer Enable (Enables MIXINR and RXVOICE input to MIXINR) 0 = Disabled 1 = Enabled
	7	IN2L_ENA	0	IN2L Input PGA Enable 0 = Disabled 1 = Enabled
	6	IN1L_ENA	0	IN1L Input PGA Enable 0 = Disabled 1 = Enabled
	5	IN2R_ENA	0	IN2R Input PGA Enable 0 = Disabled 1 = Enabled
	4	IN1R_ENA	0	IN1R Input PGA Enable 0 = Disabled 1 = Enabled
R3 (0003h) Power Management (3)	13	LINEOUT1N_ENA	0	LINEOUT1N Line Out and LINEOUT1NMIX Enable 0 = Disabled 1 = Enabled
	12	LINEOUT1P_ENA	0	LINEOUT1P Line Out and LINEOUT1PMIX Enable 0 = Disabled 1 = Enabled
	11	LINEOUT2N_ENA	0	LINEOUT2N Line Out and LINEOUT2NMIX Enable 0 = Disabled 1 = Enabled
	10	LINEOUT2P_ENA	0	LINEOUT2P Line Out and LINEOUT2PMIX Enable 0 = Disabled 1 = Enabled
	9	SPKRVOL_ENA	0	SPKMIXR Mixer and SPKRVOL PGA Enable 0 = Disabled 1 = Enabled Note that SPKMIXR and SPKRVOL are also enabled when SPKOUTR_ENA is set.
	8	SPKLVOL_ENA	0	SPKMIXL Mixer and SPKLVOL PGA Enable 0 = Disabled 1 = Enabled Note that SPKMIXL and SPKLVOL are also enabled when SPKOUTL_ENA is set.
	7	MIXOUTLVOL_ENA	0	MIXOUTL Left Volume Control Enable 0 = Disabled 1 = Enabled
	6	MIXOUTRVOL_ENA	0	MIXOUTR Right Volume Control Enable 0 = Disabled 1 = Enabled

REGISTER ADDRESS	BIT	LABEL	DEFAULT	DESCRIPTION
	5	MIXOUTL_ENA	0	MIXOUTL Left Output Mixer Enable 0 = Disabled 1 = Enabled
	4	MIXOUTR_ENA	0	MIXOUTR Right Output Mixer Enable 0 = Disabled 1 = Enabled
R4 (0004h) Power Management (4)	13	AIF2ADCL_ENA	0	Enable AIF2ADC (Left) output path 0 = Disabled 1 = Enabled This bit must be set for AIF2 or AIF3 output of the AIF2ADC (Left) signal.
	12	AIF2ADCR_ENA	0	Enable AIF2ADC (Right) output path 0 = Disabled 1 = Enabled This bit must be set for AIF2 or AIF3 output of the AIF2ADC (Left) signal.
	9	AIF1ADC1L_ENA	0	Enable AIF1ADC (Left) output path 0 = Disabled 1 = Enabled
	8	AIF1ADC1R_ENA	0	Enable AIF1ADC (Right) output path 0 = Disabled 1 = Enabled
	3	DMIC1L_ENA	0	Digital microphone (DMICDAT) Left channel enable 0 = Disabled 1 = Enabled
	2	DMIC1R_ENA	0	Digital microphone (DMICDAT) Right channel enable 0 = Disabled 1 = Enabled
	1	ADCL_ENA	0	Left ADC Enable 0 = Disabled 1 = Enabled
	0	ADCR_ENA	0	Right ADC Enable 0 = Disabled 1 = Enabled
R5 (0005h) Power Management (5)	13	AIF2DACL_ENA	0	Enable AIF2DAC (Left) input path 0 = Disabled 1 = Enabled
	12	AIF2DACR_ENA	0	Enable AIF2DAC (Right) input path 0 = Disabled 1 = Enabled
	9	AIF1DAC1L_ENA	0	Enable AIF1DAC (Left) input path 0 = Disabled 1 = Enabled
	8	AIF1DAC1R_ENA	0	Enable AIF1DAC (Right) input path 0 = Disabled 1 = Enabled
	1	DAC1L_ENA	0	Left DAC Enable 0 = Disabled 1 = Enabled
	0	DAC1R_ENA	0	Right DAC Enable 0 = Disabled

REGISTER ADDRESS	BIT	LABEL	DEFAULT	DESCRIPTION
				1 = Enabled
R76 (004Ch) Charge Pump (1)	15	CP_ENA	0	Enable charge-pump digits 0 = Disable 1 = Enable
R84 (0054h) DC Servo (1)	1	DCS_ENA_CHAN_1	0	DC Servo enable for HPOUT1R 0 = Disabled 1 = Enabled
	0	DCS_ENA_CHAN_0	0	DC Servo enable for HPOUT1L 0 = Disabled 1 = Enabled
R512 (0200h) AIF 1 Clocking (1)	0	AIF1CLK_ENA	0	AIF1CLK Enable 0 = Disabled 1 = Enabled
R516 (0204h) AIF 2 Clocking (1)	0	AIF2CLK_ENA	0	AIF2CLK Enable 0 = Disabled 1 = Enabled
R520 (0208h) Clocking (1)	4	TOCLK_ENA	0	Slow Clock (TOCLK) Enable 0 = Disabled 1 = Enabled This clock is required for zero-cross timeout.
	3	AIF1DSPCLK_ENA	0	AIF1 Processing Clock Enable 0 = Disabled 1 = Enabled
	2	AIF2DSPCLK_ENA	0	AIF2 Processing Clock Enable 0 = Disabled 1 = Enabled
	1	SYSDSPCLK_ENA	0	Digital Mixing Processor Clock Enable 0 = Disabled 1 = Enabled
R544 (0220h) FLL1 Control (1)	0	FLL1_ENA	0	FLL1 Enable 0 = Disabled 1 = Enabled This should be set as the final step of the FLL1 enable sequence, ie. after the other FLL registers have been configured.
R576 (0240h) FLL2 Control (1)	0	FLL2_ENA	0	FLL2 Enable 0 = Disabled 1 = Enabled This should be set as the final step of the FLL2 enable sequence, ie. after the other FLL registers have been configured.

Table 130 Power Management

## THERMAL SHUTDOWN

The WM1811A incorporates a temperature sensor which detects when the device temperature is within normal limits or if the device is approaching a hazardous temperature condition. The temperature sensor can be configured to automatically disable the audio outputs of the WM1811A in response to an overtemperature condition (approximately 150°C).

The temperature status can be output directly on a GPIO pin, as described in the “General Purpose Input/Output” section. The temperature sensor can also be used to generate Interrupt events, as described in the “Interrupts” section. The GPIO and Interrupt functions can be used to indicate either a Warning Temperature event or the Shutdown Temperature event.

The temperature sensor is enabled by setting the TSHUT\_ENA register bit. When the TSHUT\_OPDIS is also set, then a device over-temperature condition will cause the speaker outputs (SPKOUTL and SPKOUTR) of the WM1811A to be disabled; this response is likely to prevent any damage to the device attributable to the large currents of the output drivers.

Note that, to prevent pops and clicks, TSHUT\_ENA and TSHUT\_OPDIS should only be updated whilst the speaker and headphone outputs are disabled.

REGISTER ADDRESS	BIT	LABEL	DEFAULT	DESCRIPTION
R2 (0002h) Power Management (2)	14	TSHUT_ENA	1	Thermal sensor enable 0 = Disabled 1 = Enabled
	13	TSHUT_OPDIS	1	Thermal shutdown control (Causes audio outputs to be disabled if an overtemperature occurs. The thermal sensor must also be enabled.) 0 = Disabled 1 = Enabled

Table 131 Thermal Shutdown

**POWER ON RESET**

The WM1811A includes a Power-On Reset (POR) circuit, which is used to reset the digital logic into a default state after power up. The POR circuit derives its output from AVDD2 and DCVDD. The internal  $\overline{\text{POR}}$  signal is asserted low when AVDD2 and DCVDD are below minimum thresholds.

The specific behaviour of the circuit will vary, depending on relative timing of the supply voltages. Typical scenarios are illustrated in Figure 80 and Figure 81.

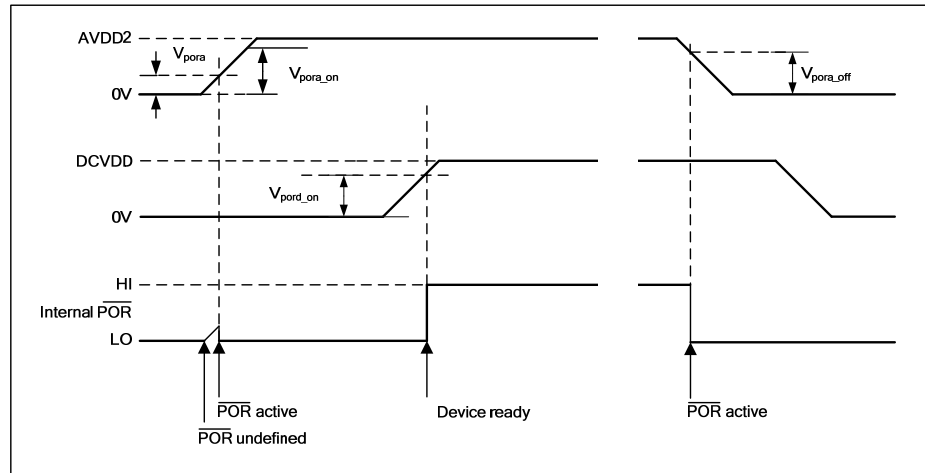

**Figure 80 Power On Reset Timing – AVDD2 enabled/disabled first**

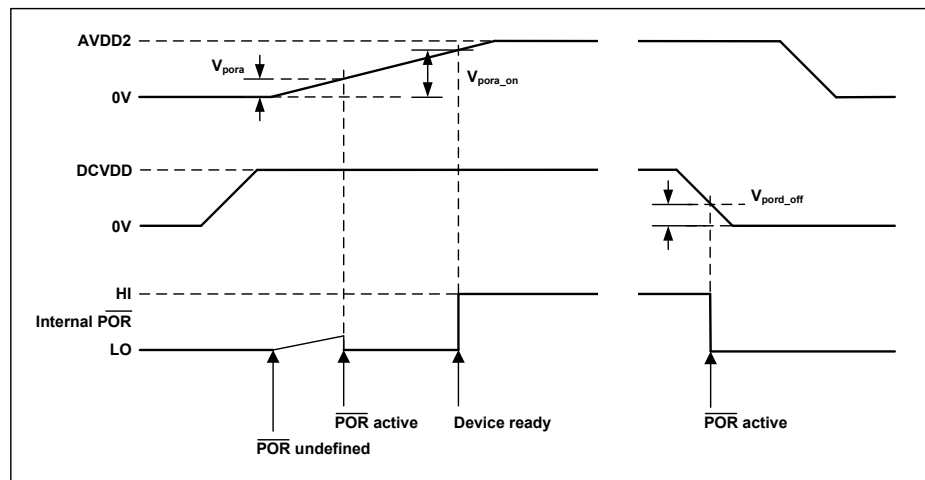

**Figure 81 Power On Reset Timing - DCVDD enabled/disabled first**

The  $\overline{\text{POR}}$  signal is undefined until AVDD2 has exceeded the minimum threshold,  $V_{\text{pora}}$ . Once this threshold has been exceeded,  $\overline{\text{POR}}$  is asserted low and the chip is held in reset. In this condition, all writes to the control interface are ignored. Once AVDD2 and DCVDD have reached their respective power on thresholds,  $\overline{\text{POR}}$  is released high, all registers are in their default state, and writes to the control interface may take place.

Note that a power-on reset period,  $T_{\text{POR}}$ , applies after AVDD2 and DCVDD have reached their respective power on thresholds. This specification is guaranteed by design rather than test.

On power down,  $\overline{\text{POR}}$  is asserted low when either AVDD2 or DCVDD falls below their respective power-down thresholds.



Typical Power-On Reset parameters for the WM1811A are defined in Table 132.

SYMBOL	DESCRIPTION	TYP	UNIT
V <sub>pora_on</sub>	Power-On threshold (AVDD2)	1.15	V
V <sub>pora_off</sub>	Power-Off threshold (AVDD2)	1.14	V
V <sub>por_d_on</sub>	Power-On threshold (DCVDD)	0.56	V
V <sub>por_d_off</sub>	Power-Off threshold (DCVDD)	0.55	V
T <sub>POR</sub>	Minimum Power-On Reset period	100	ns

**Table 132 Typical Power-On Reset Parameters**

Table 133 describes the status of the WM1811A digital I/O pins when the Power On Reset has completed, prior to any register writes. The same conditions apply on completion of a Software Reset (described in the "Software Reset and Device ID" section).

PIN NO	NAME	TYPE	RESET STATUS
<b>DBVDD1 power domain</b>			
D5	SPKMODE	Digital Input	Pull-up to DBVDD1
A4	LDO1ENA	Digital Input	Pull-down to DGND
F3	ADDR	Digital Input	Pull-down to DGND
D6	LDO2ENA	Digital Input	Pull-down to DGND
H2	SCLK	Digital Input	Digital input
H3	SDA	Digital Input/Output	Digital input
F1	MCLK1	Digital Input	Digital input
F2	MCLK2	Digital Input	Pull-down to DGND
G3	BCLK1	Digital Input/Output	Digital input
G1	LRCLK1	Digital Input/Output	Digital input
J1	ADCLRCLK1/GPIO1	Digital Input/Output	Digital input
H1	DACDAT1	Digital Input	Digital input
F4	ADCAT1	Digital Output	Digital output
<b>DBVDD2 power domain</b>			
K1	BCLK2	Digital Input/Output	Digital input, Pull-down to DGND
J3	LRCLK2	Digital Input/Output	Digital input, Pull-down to DGND
G4	DACDAT2	Digital Input	Pull-down to DGND
H4	ADCAT2	Digital Output	Digital output
<b>DBVDD3 power domain</b>			
K4	GPIO11/BCLK3	Digital Input/Output	Digital input, Pull-down to DGND
G5	GPIO10/LRCLK3	Digital Input/Output	Digital input, Pull-down to DGND
K3	GPIO8/DACDAT3	Digital Input/Output	Digital input, Pull-down to DGND
J4	GPIO9/ADCAT3	Digital Input/Output	Digital input, Pull-down to DGND
<b>MICBIAS1 power domain</b>			
A8	DMICCLK	Digital Output	Digital output
C8	IN2LN/DMICDAT	Analogue Input/Digital Input	Analogue input

**Table 133 WM1811A Digital I/O Status in Reset**

Note that the dual function IN2LN/DMICDAT pin defaults to IN2LN (analogue input) after Power On Reset is completed. The IN2LN function is referenced to the AVDD1 power domain.

## SOFTWARE RESET AND DEVICE ID

The device ID can be read back from register R0. Writing to this register will reset the device.

The software reset causes all control registers to be reset to their default state.

The status of the WM1811A digital I/O pins following a software reset is described in Table 133.

The Customer ID and Device Revision can be read back from register R256.

REGISTER ADDRESS	BIT	LABEL	DEFAULT	DESCRIPTION
R0 (0000h) Software Reset	15:0	SW_RESET [15:0]	1811h	Writing to this register resets all registers to their default state. Reading from this register will indicate device ID 1811h.
R256 (0100h) Chip Revision	15:8	CUST_ID [7:0]		Customer ID
	3:0	CHIP_REV [3:0]		Chip revision

**Table 134 Chip Reset and ID**

## REGISTER MAP

The WM1811A control registers are listed below. Note that only the register addresses described here should be accessed; writing to other addresses may result in undefined behaviour. Register bits that are not documented should not be changed from the default values.

REG	NAME	15	14	13	12	11	10	9	8	7	6	5	4	3	2	1	0	DEFAULT
R0 (0h)	Software Reset	SW_RESET [15:0]																0000h
R1 (1h)	Power Management (1)	0	0	SPKO UTR_ ENA	SPKO UTL_ ENA	HPOU T2_En A	0	HPOU T1L_ ENA	HPOU T1R_ ENA	0	0	MICB2 _ENA	MICB1 _ENA	0	VMID_SEL [1:0]		BIAS_ ENA	0000h
R2 (2h)	Power Management (2)	0	TSHU T_EnA	TSHU T_EnA	0	OPCL K_En A	0	MIXIN L_EnA	MIXIN R_En A	IN2L_ EnA	IN1L_ EnA	IN2R_ EnA	IN1R_ EnA	0	0	0	0	6000h
R3 (3h)	Power Management (3)	0	0	LINEO UT1N_ EnA	LINEO UT1P_ EnA	LINEO UT2N_ EnA	LINEO UT2P_ EnA	SPKR VOL_En A	SPKLV OL_En A	MIXO UTLV OL_En A	MIXO UTRV OL_En A	MIXO UTL_En A	MIXO UTR_En A	0	0	0	0	0000h
R4 (4h)	Power Management (4)	0	0	AIF2A DCL_En A	AIF2A DCR_En A	0	0	AIF1A DC1L_En A	AIF1A DC1R_En A	0	0	0	0	DMIC1 L_EnA	DMIC1 R_En A	ADCL_ EnA	ADCR_ EnA	0000h
R5 (5h)	Power Management (5)	0	0	AIF2D ACL_En A	AIF2D ACR_En A	0	0	AIF1D AC1L_En A	AIF1D AC1R_En A	0	0	0	0	0	0	DAC1L_ EnA	DAC1 R_En A	0000h
R6 (6h)	Power Management (6)	0	0	0	0	0	AIF3ADC_SRC [1:0]	AIF2DAC_SRC [1:0]	0	0	AIF3_ TRI	AIF3_ADCDAT_ SRC [1:0]	AIF2_ ADCD AT_SR C	AIF2_ DACD AT_SR C	AIF1_ DACD AT_SR C	0	0	0000h
R21 (15h)	Input Mixer (1)	0	0	0	0	0	0	0	IN1RP _MIXI NR_B OOST	IN1LP _MIXI NL_B OOST	INPUT S_CLA MP	0	0	0	0	0	0	0000h
R24 (18h)	Left Line Input 1&2 Volume	0	0	0	0	0	0	0	IN1_V U	IN1L_ MUTE	IN1L_ ZC	0	IN1L_VOL [4:0]				008Bh	
R25 (19h)	Left Line Input 3&4 Volume	0	0	0	0	0	0	0	IN2_V U	IN2L_ MUTE	IN2L_ ZC	0	IN2L_VOL [4:0]				008Bh	
R26 (1Ah)	Right Line Input 1&2 Volume	0	0	0	0	0	0	0	IN1_V U	IN1R_ MUTE	IN1R_ ZC	0	IN1R_VOL [4:0]				008Bh	
R27 (1Bh)	Right Line Input 3&4 Volume	0	0	0	0	0	0	0	IN2_V U	IN2R_ MUTE	IN2R_ ZC	0	IN2R_VOL [4:0]				008Bh	
R28 (1Ch)	Left Output Volume	0	0	0	0	0	0	0	HPOU T1_VU	HPOU T1L_Z C	HPOU T1L_M UTE_ N	HPOUT1L_VOL [5:0]					006Dh	
R29 (1Dh)	Right Output Volume	0	0	0	0	0	0	0	HPOU T1_VU	HPOU T1R_Z C	HPOU T1R_M UTE_ N	HPOUT1R_VOL [5:0]					006Dh	
R30 (1Eh)	Line Outputs Volume	0	0	0	0	0	0	0	0	0	LINEO UT1N_ MUTE	LINEO UT1P_ MUTE	LINEO UT1_V OL	0	LINEO UT2N_ MUTE	LINEO UT2P_ MUTE	LINEO UT2_V OL	0066h
R31 (1Fh)	HPOUT2 Volume	0	0	0	0	0	0	0	0	0	HPOU T2_M UTE	HPOU T2_VO L	0	0	0	0	0	0020h
R32 (20h)	Left OPGA Volume	0	0	0	0	0	0	0	MIXO UT_V U	MIXO UTL_Z C	MIXO UTL_ MUTE _N	MIXOUTL_VOL [5:0]					0079h	

REG	NAME	15	14	13	12	11	10	9	8	7	6	5	4	3	2	1	0	DEFAULT
R33 (21h)	Right OPGA Volume	0	0	0	0	0	0	0	MIXO UT_V U	MIXO UTR_Z C	MIXO UTR_ MUTE _N	MIXOUTR_VOL [5:0]					0079h	
R34 (22h)	SPKMIXL Attenuation	0	0	0	0	0	0	0	0	0	0	MIXIN L_SPK MIXL_ VOL	IN1LP _SPK MIXL_ VOL	MIXO UTL_S PKMIX L_VOL	DAC1L _SPK MIXL_ VOL	SPKMIXL_VOL [1:0]		0003h
R35 (23h)	SPKMIXR Attenuation	0	0	0	0	0	0	0	0	0	0	MIXIN R_SP KMIXR _VOL	IN1RP _SPK MIXR_ VOL	MIXO UTR_ SPKMI XR_V OL	DAC1 R_SP KMIXR _VOL	SPKMIXR_VO L [1:0]		0003h
R36 (24h)	SPKOUT Mixers	0	0	0	0	0	0	0	0	0	0	IN2LR P_TO_ SPKO UTL	SPKMI XL_TO _SPK OUTL	SPKMI XR_T O_SP KOUT L	IN2LR P_TO_ SPKO UTR	SPKMI XL_TO _SPK OUTR	SPKMI XR_T O_SP KOUT R	0011h
R37 (25h)	ClassD	0	0	0	0	0	0	0	1	0	1	SPKOUTL_BOOST [2:0]		SPKOUTR_BOOST [2:0]		0140h		
R38 (26h)	Speaker Volume Left	0	0	0	0	0	0	0	SPKO UT_V U	SPKO UTL_Z C	SPKO UTL_ MUTE _N	SPKOUTL_VOL [5:0]					0079h	
R39 (27h)	Speaker Volume Right	0	0	0	0	0	0	0	SPKO UT_V U	SPKO UTR_Z C	SPKO UTR_ MUTE _N	SPKOUTR_VOL [5:0]					0079h	
R40 (28h)	Input Mixer (2)	0	0	0	0	0	0	0	0	IN2LP _TO_I N2L	IN2LN _TO_I N2L	IN1LP _TO_I N1L	IN1LN _TO_I N1L	IN2RP _TO_I N2R	IN2RN _TO_I N2R	IN1RP _TO_I N1R	IN1RN _TO_I N1R	0000h
R41 (29h)	Input Mixer (3)	0	0	0	0	0	0	0	IN2L TO_MI XINL	IN2L MIXIN L_VOL	0	IN1L TO_MI XINL	IN1L MIXIN L_VOL	0	MIXOUTL_MIXINL_VO L [2:0]		0000h	
R42 (2Ah)	Input Mixer (4)	0	0	0	0	0	0	0	IN2R TO_MI XINR	IN2R MIXIN R_VO L	0	IN1R TO_MI XINR	IN1R MIXIN R_VO L	0	MIXOUTR_MIXINR_VO L [2:0]		0000h	
R43 (2Bh)	Input Mixer (5)	0	0	0	0	0	0	0	IN1LP_MIXINL_VOL [2:0]		0	0	0	IN2LRP_MIXINL_VOL [2:0]		0000h		
R44 (2Ch)	Input Mixer (6)	0	0	0	0	0	0	0	IN1RP_MIXINR_VOL [2:0]		0	0	0	IN2LRP_MIXINR_VOL [2:0]		0000h		
R45 (2Dh)	Output Mixer (1)	0	0	0	0	0	0	0	DAC1L _TO_H POUT 1L	MIXIN R_TO_ MIXO UTL	MIXIN L_TO_ MIXO UTL	IN2RN _TO_ MIXO UTL	IN2LN _TO_ MIXO UTL	IN1R _TO_MI XOUT L	IN1L _TO_MI XOUT L	IN2LP _TO_ MIXO UTL	DAC1L _TO_ MIXO UTL	0000h
R46 (2Eh)	Output Mixer (2)	0	0	0	0	0	0	0	DAC1 R_TO_ HPOU T1R	MIXIN L_TO_ MIXO UTR	MIXIN R_TO_ MIXO UTR	IN2LN _TO_ MIXO UTR	IN2RN _TO_ MIXO UTR	IN1L _TO_MI XOUT R	IN1R _TO_MI XOUT R	IN2RP _TO_ MIXO UTR	DAC1 R_TO_ MIXO UTR	0000h
R47 (2Fh)	Output Mixer (3)	0	0	0	0	IN2LP_MIXOUTL_VOL [2:0]		IN2LN_MIXOUTL_VOL [2:0]		IN1R_MIXOUTL_VOL [2:0]		IN1L_MIXOUTL_VOL [2:0]		0000h				
R48 (30h)	Output Mixer (4)	0	0	0	0	IN2RP_MIXOUTR_VOL [2:0]		IN2RN_MIXOUTR_VOL [2:0]		IN1L_MIXOUTR_VOL [2:0]		IN1R_MIXOUTR_VOL [2:0]		0000h				
R49 (31h)	Output Mixer (5)	0	0	0	0	DAC1L_MIXOUTL_VO L [2:0]		IN2RN_MIXOUTL_VOL [2:0]		MIXINR_MIXOUTL_VO L [2:0]		MIXINL_MIXOUTL_VO L [2:0]		0000h				
R50 (32h)	Output Mixer (6)	0	0	0	0	DAC1R_MIXOUTR_VO L [2:0]		IN2LN_MIXOUTR_VOL [2:0]		MIXINL_MIXOUTR_VO L [2:0]		MIXINR_MIXOUTR_VO L [2:0]		0000h				

REG	NAME	15	14	13	12	11	10	9	8	7	6	5	4	3	2	1	0	DEFAULT
R51 (33h)	HPOUT2 Mixer	0	0	0	0	0	0	0	0	0	0	IN2LR P_TO_ HPOU T2	MIXO UTLV OL_T O_HP OUT2	MIXO UTRV OL_T O_HP OUT2	0	0	0	0000h
R52 (34h)	Line Mixer (1)	0	0	0	0	0	0	0	0	0	MIXO UTL_T O_LIN EOUT 1N	MIXO UTR_T O_LIN EOUT 1N	LINEO UT1_ MODE	0	IN1R_ TO_LI NEOU T1P	IN1L_ TO_LI NEOU T1P	MIXO UTL_T O_LIN EOUT 1P	0000h
R53 (35h)	Line Mixer (2)	0	0	0	0	0	0	0	0	0	MIXO UTR_T O_LIN EOUT 2N	MIXO UTL_T O_LIN EOUT 2N	LINEO UT2_ MODE	0	IN1L_ TO_LI NEOU T2P	IN1R_ TO_LI NEOU T2P	MIXO UTR_T O_LIN EOUT 2P	0000h
R54 (36h)	Speaker Mixer	0	0	0	0	0	0	0	0	MIXIN L_TO_ SPKMI XL	MIXIN R_TO_ SPKMI XR	IN1LP _TO_S PKMIX L	IN1RP _TO_S PKMIX R	MIXO UTL_T O_SP KMIXL	MIXO UTR_T O_SP KMIXR	DAC1L _TO_S PKMIX L	DAC1 R_TO_ SPKMI XR	0000h
R55 (37h)	Additional Control	0	0	0	0	0	0	0	0	LINEO UT1_F B	LINEO UT2_F B	0	0	0	0	0	VROI	0000h
R56 (38h)	AntiPOP (1)	0	0	0	0	0	0	0	0	LINEO UT_V MID_B UF_E NA	HPOU T2_IN _ENA	LINEO UT1_D ISCH	LINEO UT2_D ISCH	0	0	0	0	0000h
R57 (39h)	AntiPOP (2)	0	0	0	0	0	0	0	JACKDET_MO DE [1:0]	VMID_RAMP [1:0]	0	VMID_ BUF_E NA	STAR TUP_B IAS_E NA	BIAS_ SRC	VMID_ DISCH	0000h		
R59 (3Bh)	LDO 1	0	0	0	0	0	0	0	0	0	0	0	0	LDO1_VSEL [2:0]			LDO1_ DISCH	000Dh
R60 (3Ch)	LDO 2	0	0	0	0	0	0	0	0	0	0	0	0	LDO2_VSEL [1:0]			LDO2_ DISCH	0003h
R61 (3Dh)	MICBIAS1	0	0	0	0	0	0	0	0	0	MICB1 _RATE	MICB1 _MOD E	MICB1_LVL [2:0]			MICB1 _DISC H	0039h	
R62 (3Eh)	MICBIAS2	0	0	0	0	0	0	0	0	0	MICB2 _RATE	MICB2 _MOD E	MICB2_LVL [2:0]			MICB2 _DISC H	0039h	
R76 (4Ch)	Charge Pump (1)	CP_E NA	0	0	1	1	1	1	1	0	0	1	0	0	1	0	1	1F25h
R77 (4Dh)	Charge Pump (2)	CP_DI SCH	0	1	0	1	0	1	1	0	0	0	1	1	0	0	1	AB19h
R81 (51h)	Class W (1)	0	0	0	0	0	0	CP_DYN_SRC _SEL [1:0]	0	0	0	0	0	0	1	0	CP_D YN_P WR	0004h
R84 (54h)	DC Servo (1)	0	0	0	0	0	0	0	0	0	0	DCS_ TRIG_ STAR TUP_1	DCS_ TRIG_ STAR TUP_0	DCS_ TRIG_ DAC_ WR_1	DCS_ TRIG_ DAC_ WR_0	DCS_ ENA_ CHAN _1	DCS_ ENA_ CHAN _0	0000h
R85 (55h)	DC Servo (2)	0	0	0	0	0	1	0	1	0	0	0	0	DCS_TIMER_PERIOD_01 [3:0]			054Ah	
R88 (58h)	DC Servo Readback	0	0	0	0	0	0	DCS_CAL_CO MPLETE [1:0]	0	0	0	DCS_DAC_WR _COMPLETE [1:0]	0	0	DCS_STARTUP P_COMPLETE [1:0]		0000h	
R89 (59h)	DC Servo (4)	DCS_DAC_WR_VAL_1 [7:0]								DCS_DAC_WR_VAL_0 [7:0]								0000h

REG	NAME	15	14	13	12	11	10	9	8	7	6	5	4	3	2	1	0	DEFAULT
R96 (60h)	Analogue HP (1)	0	0	0	0	0	0	0	HPOU T1_AT TN	HPOU T1L_R MV_S HORT	HPOU T1L_O UTP	HPOU T1L_D LY	0	HPOU T1R_R MV_S HORT	HPOU T1R_O UTP	HPOU T1R_D LY	0	0000h
R197 (C5h)	Class D Test (5)	0	0	0	0	0	0	0	0	0	0	0	0	0	0	0	SPKO UT_CL K_SR C	0000h
R208 (D0h)	Mic Detect 1	MICD_BIAS_STARTTIME [3:0]				MICD_RATE [3:0]				0	0	0	0	0	0	MICD_ DBTIM E	MICD_ ENA	7600h
R209 (D1h)	Mic Detect 2	0	0	0	0	0	0	0	0	MICD_LVL_SEL [7:0]							007Fh	
R210 (D2h)	Mic Detect 3	0	0	0	0	0	MICD_LVL [8:0]									MICD_ VALID	MICD_ STS	0000h
R256 (100h)	Chip Revision	CUST_ID [7:0]								0	0	0	0	CHIP_REV [3:0]			XX0Xh	
R257 (101h)	Control Interface	1	0	0	0	0	0	0	0	0	0	0	0	0	AUTO _INC	0	0	8004h
R512 (200h)	AIF1 Clocking (1)	0	0	0	0	0	0	0	0	0	0	AIF1CLK_SRC [1:0]	AIF1C LK_IN V	AIF1C LK_DI V	AIF1C LK_EN A	0000h		
R513 (201h)	AIF1 Clocking (2)	0	0	0	0	0	0	0	0	0	AIF1DAC_DIV [2:0]		AIF1ADC_DIV [2:0]			0000h		
R516 (204h)	AIF2 Clocking (1)	0	0	0	0	0	0	0	0	0	0	AIF2CLK_SRC [1:0]	AIF2C LK_IN V	AIF2C LK_DI V	AIF2C LK_EN A	0000h		
R520 (208h)	Clocking (1)	0	0	0	0	0	0	0	0	0	0	TOCL K_EN A	AIF1D SPCL K_EN A	AIF2D SPCL K_EN A	SYSD SPCL K_EN A	SYSC LK_SR C	0000h	
R521 (209h)	Clocking (2)	0	0	0	0	0	TOCLK_DIV [2:0]		0	DBCLK_DIV [2:0]		0	OPCLK_DIV [2:0]			0000h		
R528 (210h)	AIF1 Rate	0	0	0	0	0	0	0	AIF1_SR [3:0]			AIF1CLK_RATE [3:0]			0083h			
R529 (211h)	AIF2 Rate	0	0	0	0	0	0	0	AIF2_SR [3:0]			AIF2CLK_RATE [3:0]			0083h			
R530 (212h)	Rate Status	0	0	0	0	0	0	0	0	0	0	0	SR_ERROR [3:0]			0000h		
R544 (220h)	FLL1 Control (1)	0	0	0	0	0	0	0	0	0	0	0	0	FLL1_ OSC_ ENA	FLL1_ ENA	0000h		
R545 (221h)	FLL1 Control (2)	0	0	FLL1_OUTDIV [5:0]					0	0	0	0	FLL1_FRATIO [2:0]			0000h		
R546 (222h)	FLL1 Control (3)	FLL1_THETA [15:0]															0000h	
R547 (223h)	FLL1 Control (4)	0	FLL1_N [9:0]									0	0	0	0	0	0000h	
R548 (224h)	FLL1 Control (5)	FLL1_ BYP	0	0	FLL1_FRC_NCO_VAL [5:0]					FLL1_ FRC_ NCO	0	FLL1_REFCLK _DIV [1:0]		0	FLL1_REFCLK _SRC [1:0]		0C80h	
R550 (226h)	FLL1 EFS 1	FLL1_LAMBDA [15:0]															0000h	
R551 (227h)	FLL1 EFS 2	0	0	0	0	0	0	0	0	0	0	0	0	1	1	FLL1_ EFS_ ENA	0006h	
R576 (240h)	FLL2Control (1)	0	0	0	0	0	0	0	0	0	0	0	0	0	FLL2_ OSC_ ENA	FLL2_ ENA	0000h	
R577 (241h)	FLL2Control (2)	0	0	FLL2_OUTDIV [5:0]					0	0	0	0	FLL2_FRATIO [2:0]			0000h		
R578 (242h)	FLL2Control (3)	FLL2_THETA [15:0]															0000h	
R579 (243h)	FLL2 Control (4)	0	FLL2_N [9:0]									0	0	0	0	0	0000h	
R580 (244h)	FLL2Control (5)	FLL2_ BYP	0	0	FLL2_FRC_NCO_VAL [5:0]					FLL2_ FRC_ NCO	0	FLL2_REFCLK _DIV [1:0]		0	FLL2_REFCLK _SRC [1:0]		0C80h	
R582 (246h)	FLL2 EFS 1	FLL2_LAMBDA [15:0]															0000h	

REG	NAME	15	14	13	12	11	10	9	8	7	6	5	4	3	2	1	0	DEFAULT
R583 (247h)	FLL2 EFS 2	0	0	0	0	0	0	0	0	0	0	0	0	0	1	1	FLL2_EFS_ENA	0006h
R768 (300h)	AIF1 Control (1)	AIF1A_DCL_SRC	AIF1A_DCR_SRC	AIF1A_DC_TDM	AIF1A_DC_TDM_CHAN	0	0	0	AIF1_BCLK_INV	0	AIF1_WL [1:0]		AIF1_FMT [1:0]		0	0	0	4050h
R769 (301h)	AIF1 Control (2)	AIF1D_ACL_SRC	AIF1D_ACR_SRC	AIF1D_AC_TDM	AIF1D_AC_TDM_CHAN	AIF1DAC_BOOT [1:0]		0	AIF1_MONO	0	0	0	AIF1D_AC_COMP	AIF1D_AC_COMP_MODE	AIF1A_DC_COMP	AIF1A_DC_COMP_MODE	AIF1_L_OOPB_ACK	4000h
R770 (302h)	AIF1 Master/Slave	AIF1_TRI	AIF1_MSTR	AIF1_CLK_FRC	AIF1_L_RCLK_FRC	0	0	0	0	0	0	0	0	0	0	0	0	0000h
R771 (303h)	AIF1 BCLK	0	0	0	0	0	0	0	AIF1_BCLK_DIV [4:0]				0	0	0	0	0040h	
R772 (304h)	AIF1ADC LRCLK	0	0	0	AIF1A_DC_LR_CLK_INV	AIF1A_DC_LR_CLK_INV	AIF1ADC_RATE [10:0]										0040h	
R773 (305h)	AIF1DAC LRCLK	0	0	0	AIF1D_AC_LR_CLK_INV	AIF1D_AC_LR_CLK_INV	AIF1DAC_RATE [10:0]										0040h	
R774 (306h)	AIF1DAC Data	0	0	0	0	0	0	0	0	0	0	0	0	0	AIF1D_ACL_DATA_INV	AIF1D_ACR_DATA_INV	0000h	
R775 (307h)	AIF1ADC Data	0	0	0	0	0	0	0	0	0	0	0	0	0	AIF1A_DCL_DATA_INV	AIF1A_DCR_DATA_INV	0000h	
R784 (310h)	AIF2 Control (1)	AIF2A_DCL_SRC	AIF2A_DCR_SRC	AIF2A_DC_TDM	AIF2A_DC_TDM_CHAN	0	0	0	AIF2_BCLK_INV	0	AIF2_WL [1:0]		AIF2_FMT [1:0]		0	0	0	4050h
R785 (311h)	AIF2 Control (2)	AIF2D_ACL_SRC	AIF2D_ACR_SRC	AIF2D_AC_TDM	AIF2D_AC_TDM_CHAN	AIF2DAC_BOOT [1:0]		0	AIF2_MONO	0	0	0	AIF2D_AC_COMP	AIF2D_AC_COMP_MODE	AIF2A_DC_COMP	AIF2A_DC_COMP_MODE	AIF2_L_OOPB_ACK	4000h
R786 (312h)	AIF2 Master/Slave	AIF2_TRI	AIF2_MSTR	AIF2_CLK_FRC	AIF2_L_RCLK_FRC	0	0	0	0	0	0	0	0	0	0	0	0	0000h
R787 (313h)	AIF2 BCLK	0	0	0	0	0	0	0	AIF2_BCLK_DIV [4:0]				0	0	0	0	0040h	
R788 (314h)	AIF2ADC LRCLK	0	0	0	AIF2A_DC_LR_CLK_INV	0	0	0	0	0	1	0	0	0	0	0	0	0040h
R789 (315h)	AIF2DAC LRCLK	0	0	0	AIF2D_AC_LR_CLK_INV	AIF2D_AC_LR_CLK_INV	AIF2DAC_RATE [10:0]										0040h	
R790 (316h)	AIF2DAC Data	0	0	0	0	0	0	0	0	0	0	0	0	0	AIF2D_ACL_DATA_INV	AIF2D_ACR_DATA_INV	0000h	
R791 (317h)	AIF2ADC Data	0	0	0	0	0	0	0	0	0	0	0	0	0	AIF2A_DCL_DATA_INV	AIF2A_DCR_DATA_INV	0000h	

REG	NAME	15	14	13	12	11	10	9	8	7	6	5	4	3	2	1	0	DEFAULT
R792 (318h)	AIF2TX Control	0	0	0	0	0	0	0	0	0	0	0	0	0	0	AIF2T XL_EN A	AIF2T XR_E NA	0003h
R800 (320h)	AIF3 Control (1)	0	0	0	0	0	0	0	0	AIF3_L RCLK_ INV	AIF3_WL [1:0]		0	0	0	0	0	0040h
R801 (321h)	AIF3 Control (2)	0	0	0	0	AIF3DAC_BOO ST [1:0]		0	0	0	0	0	AIF3D AC_C OMP	AIF3D AC_C OMPM ODE	AIF3A DC_C OMP	AIF3A DC_C OMPM ODE	AIF3_L OOPB ACK	0000h
R802 (322h)	AIF3DAC Data	0	0	0	0	0	0	0	0	0	0	0	0	0	0	0	AIF3D AC_D AT_IN V	0000h
R803 (323h)	AIF3ADC Data	0	0	0	0	0	0	0	0	0	0	0	0	0	0	0	AIF3A DC_D AT_IN V	0000h
R1024 (400h)	AIF1 ADC1 Left Volume	0	0	0	0	0	0	0	AIF1A DC1_V U	AIF1ADC1L_VOL [7:0]							00C0h	
R1025 (401h)	AIF1 ADC1 Right Volume	0	0	0	0	0	0	0	AIF1A DC1_V U	AIF1ADC1R_VOL [7:0]							00C0h	
R1026 (402h)	AIF1 DAC1 Left Volume	0	0	0	0	0	0	0	AIF1D AC1_V U	AIF1DAC1L_VOL [7:0]							00C0h	
R1027 (403h)	AIF1 DAC1 Right Volume	0	0	0	0	0	0	0	AIF1D AC1_V U	AIF1DAC1R_VOL [7:0]							00C0h	
R1040 (410h)	AIF1 ADC1 Filters	AIF1A DC_4F S	AIF1ADC1_HP F_CUT [1:0]	AIF1A DC1L_ HPF	AIF1A DC1R_ HPF	0	0	0	0	0	0	0	0	0	0	0	0	0000h
R1056 (420h)	AIF1 DAC1 Filters (1)	0	0	0	0	0	0	AIF1D AC1_ MUTE	0	AIF1D AC1_ MONO	0	AIF1D AC1_ MUTE RATE	AIF1D AC1_U NMUT E_RA MP	0	0	0	0	0200h
R1057 (421h)	AIF1 DAC1 Filters (2)	0	0	AIF1DAC1_3D_GAIN [4:0]				AIF1D AC1_3 D_EN A	0	0	0	0	1	0	0	0	0	0010h
R1072 (430h)	AIF1 DAC1 Noise Gate	0	0	0	0	0	0	0	0	0	AIF1DAC1_NG _HLD [1:0]	0	AIF1DAC1_NG_THR [2:0]		AIF1D AC1_N G_EN A	0068h		
R1088 (440h)	AIF1 DRC1 (1)	AIF1DRC1_SIG_DET_RMS [4:0]				AIF1DRC1_SI G_DET_PK [1:0]	AIF1D RC1_N G_EN A	AIF1D RC1_S IG_DE T_MO DE	AIF1D RC1_S IG_DE T	AIF1D RC1_K NEE2_ OP_E NA	AIF1D RC1_ OR	AIF1D RC1_A NTICLI P	AIF1D AC1_D RC_E NA	AIF1A DC1L_ DRC_ ENA	AIF1A DC1R_ DRC_ ENA	0098h		
R1089 (441h)	AIF1 DRC1 (2)	0	0	0	AIF1DRC1_ATK [3:0]			AIF1DRC1_DCY [3:0]			AIF1DRC1_MINGAIN [2:0]		AIF1DRC1_MA XGAIN [1:0]		0845h			
R1090 (442h)	AIF1 DRC1 (3)	AIF1DRC1_NG_MINGAIN [3:0]			AIF1DRC1_NG _EXP [1:0]	AIF1DRC1_OR _THR [1:0]	AIF1DRC1_OR _DCY [1:0]	AIF1DRC1_HI_COMP [2:0]		AIF1DRC1_LO_COMP [2:0]		0000h						
R1091 (443h)	AIF1 DRC1 (4)	0	0	0	0	AIF1DRC1_KNEE_IP [5:0]					AIF1DRC1_KNEE_OP [4:0]					0000h		
R1092 (444h)	AIF1 DRC1 (5)	0	0	0	0	AIF1DRC1_KNEE2_IP [4:0]					AIF1DRC1_KNEE2_OP [4:0]					0000h		



REG	NAME	15	14	13	12	11	10	9	8	7	6	5	4	3	2	1	0	DEFAULT
R1152 (480h)	AIF1 DAC1 EQ Gains (1)	AIF1DAC1_EQ_B1_GAIN [4:0]					AIF1DAC1_EQ_B2_GAIN [4:0]					AIF1DAC1_EQ_B3_GAIN [4:0]					AIF1DAC1_EQ_ENA	6318h
R1153 (481h)	AIF1 DAC1 EQ Gains (2)	AIF1DAC1_EQ_B4_GAIN [4:0]					AIF1DAC1_EQ_B5_GAIN [4:0]					0	0	0	0	0	AIF1DAC1_EQ_MODE	6300h
R1154 (482h)	AIF1 DAC1 EQ Band 1 A	AIF1DAC1_EQ_B1_A [15:0]															0FCAh	
R1155 (483h)	AIF1 DAC1 EQ Band 1 B	AIF1DAC1_EQ_B1_B [15:0]															0400h	
R1156 (484h)	AIF1 DAC1 EQ Band 1 PG	AIF1DAC1_EQ_B1_PG [15:0]															00D8h	
R1157 (485h)	AIF1 DAC1 EQ Band 2 A	AIF1DAC1_EQ_B2_A [15:0]															1EB5h	
R1158 (486h)	AIF1 DAC1 EQ Band 2 B	AIF1DAC1_EQ_B2_B [15:0]															F145h	
R1159 (487h)	AIF1 DAC1 EQ Band 2 C	AIF1DAC1_EQ_B2_C [15:0]															0B75h	
R1160 (488h)	AIF1 DAC1 EQ Band 2 PG	AIF1DAC1_EQ_B2_PG [15:0]															01C5h	
R1161 (489h)	AIF1 DAC1 EQ Band 3 A	AIF1DAC1_EQ_B3_A [15:0]															1C58h	
R1162 (48Ah)	AIF1 DAC1 EQ Band 3 B	AIF1DAC1_EQ_B3_B [15:0]															F373h	
R1163 (48Bh)	AIF1 DAC1 EQ Band 3 C	AIF1DAC1_EQ_B3_C [15:0]															0A54h	
R1164 (48Ch)	AIF1 DAC1 EQ Band 3 PG	AIF1DAC1_EQ_B3_PG [15:0]															0558h	
R1165 (48Dh)	AIF1 DAC1 EQ Band 4 A	AIF1DAC1_EQ_B4_A [15:0]															168Eh	
R1166 (48Eh)	AIF1 DAC1 EQ Band 4 B	AIF1DAC1_EQ_B4_B [15:0]															F829h	
R1167 (48Fh)	AIF1 DAC1 EQ Band 4 C	AIF1DAC1_EQ_B4_C [15:0]															07ADh	
R1168 (490h)	AIF1 DAC1 EQ Band 4 PG	AIF1DAC1_EQ_B4_PG [15:0]															1103h	
R1169 (491h)	AIF1 DAC1 EQ Band 5 A	AIF1DAC1_EQ_B5_A [15:0]															0564h	
R1170 (492h)	AIF1 DAC1 EQ Band 5 B	AIF1DAC1_EQ_B5_B [15:0]															0559h	
R1171 (493h)	AIF1 DAC1 EQ Band 5 PG	AIF1DAC1_EQ_B5_PG [15:0]															4000h	
R1172 (494h)	AIF1 DAC1 EQ Band 1 C	AIF1DAC1_EQ_B1_C [15:0]															0000h	
R1280 (500h)	AIF2 ADC Left Volume	0	0	0	0	0	0	0	AIF2ADC_VU	AIF2ADCL_VOL [7:0]					00C0h			
R1281 (501h)	AIF2 ADC Right Volume	0	0	0	0	0	0	0	AIF2ADC_VU	AIF2ADCR_VOL [7:0]					00C0h			
R1282 (502h)	AIF2 DAC Left Volume	0	0	0	0	0	0	0	AIF2DAC_VU	AIF2DAACL_VOL [7:0]					00C0h			

REG	NAME	15	14	13	12	11	10	9	8	7	6	5	4	3	2	1	0	DEFAULT	
R1283 (503h)	AIF2 DAC Right Volume	0	0	0	0	0	0	0	AIF2D AC_V U	AIF2DACR_VOL [7:0]								00C0h	
R1296 (510h)	AIF2 ADC Filters	0	AIF2ADC_HPF _CUT [1:0]		AIF2A DCL_H PF	AIF2A DCR_ HPF	0	0	0	0	0	0	0	0	0	0	0	0000h	
R1312 (520h)	AIF2 DAC Filters (1)	0	0	0	0	0	0	AIF2D AC_M UTE	0	AIF2D AC_M ONO	0	AIF2D AC_M UTER ATE	AIF2D AC_U NMUT E_RA MP	0	0	0	0	0200h	
R1313 (521h)	AIF2 DAC Filters (2)	0	0	AIF2DAC_3D_GAIN [4:0]				AIF2D AC_3D _ENA	0	0	0	0	1	0	0	0	0	0	0010h
R1328 (530h)	AIF2 DAC Noise Gate	0	0	0	0	0	0	0	0	0	AIF2DAC_NG_ HLD [1:0]		0	AIF2DAC_NG_THR [2:0]		AIF2D AC_N G_EN A	0068h		
R1344 (540h)	AIF2 DRC (1)	AIF2DRC_SIG_DET_RMS [4:0]				AIF2DRC_SIG _DET_PK [1:0]			AIF2D RC_N G_EN A	AIF2D RC_SI G_DE T_MO DE	AIF2D RC_SI G_DE T	AIF2D RC_K NEE2_ OP_E NA	AIF2D RC_O R	AIF2D RC_A NTICLI P	AIF2D AC_D RC_E NA	AIF2A DCL_D RC_E NA	AIF2A DCR_ DRC_ ENA	0098h	
R1345 (541h)	AIF2 DRC (2)	0	0	0	AIF2DRC_ATK [3:0]				AIF2DRC_DCY [3:0]			AIF2DRC_MINGAIN [2:0]		AIF2DRC_MAX GAIN [1:0]		0845h			
R1346 (542h)	AIF2 DRC (3)	AIF2DRC_NG_MINGAIN [3:0]				AIF2DRC_NG_ EXP [1:0]	AIF2DRC_OR_ THR [1:0]	AIF2DRC_OR_ DCY [1:0]	AIF2DRC_HI_COMP [2:0]		AIF2DRC_LO_COMP [2:0]		0000h						
R1347 (543h)	AIF2 DRC (4)	0	0	0	0	0	AIF2DRC_KNEE_IP [5:0]				AIF2DRC_KNEE_OP [4:0]				0000h				
R1348 (544h)	AIF2 DRC (5)	0	0	0	0	0	AIF2DRC_KNEE2_IP [4:0]				AIF2DRC_KNEE2_OP [4:0]				0000h				
R1408 (580h)	AIF2 EQ Gains (1)	AIF2DAC_EQ_B1_GAIN [4:0]				AIF2DAC_EQ_B2_GAIN [4:0]				AIF2DAC_EQ_B3_GAIN [4:0]				AIF2D AC_E Q_EN A	6318h				
R1409 (581h)	AIF2 EQ Gains (2)	AIF2DAC_EQ_B4_GAIN [4:0]				AIF2DAC_EQ_B5_GAIN [4:0]				0	0	0	0	0	AIF2D AC_E Q_MO DE	6300h			
R1410 (582h)	AIF2 EQ Band 1 A	AIF2DAC_EQ_B1_A [15:0]																0FCAh	
R1411 (583h)	AIF2 EQ Band 1 B	AIF2DAC_EQ_B1_B [15:0]																0400h	
R1412 (584h)	AIF2 EQ Band 1 PG	AIF2DAC_EQ_B1_PG [15:0]																00D8h	
R1413 (585h)	AIF2 EQ Band 2 A	AIF2DAC_EQ_B2_A [15:0]																1EB5h	
R1414 (586h)	AIF2 EQ Band 2 B	AIF2DAC_EQ_B2_B [15:0]																F145h	
R1415 (587h)	AIF2 EQ Band 2 C	AIF2DAC_EQ_B2_C [15:0]																0B75h	
R1416 (588h)	AIF2 EQ Band 2 PG	AIF2DAC_EQ_B2_PG [15:0]																01C5h	
R1417 (589h)	AIF2 EQ Band 3 A	AIF2DAC_EQ_B3_A [15:0]																1C58h	
R1418 (58Ah)	AIF2 EQ Band 3 B	AIF2DAC_EQ_B3_B [15:0]																F373h	
R1419 (58Bh)	AIF2 EQ Band 3 C	AIF2DAC_EQ_B3_C [15:0]																0A54h	
R1420 (58Ch)	AIF2 EQ Band 3 PG	AIF2DAC_EQ_B3_PG [15:0]																0558h	
R1421 (58Dh)	AIF2 EQ Band 4 A	AIF2DAC_EQ_B4_A [15:0]																168Eh	
R1422 (58Eh)	AIF2 EQ Band 4 B	AIF2DAC_EQ_B4_B [15:0]																F829h	
R1423 (58Fh)	AIF2 EQ Band 4 C	AIF2DAC_EQ_B4_C [15:0]																07ADh	
R1424 (590h)	AIF2 EQ Band 4 PG	AIF2DAC_EQ_B4_PG [15:0]																1103h	

REG	NAME	15	14	13	12	11	10	9	8	7	6	5	4	3	2	1	0	DEFAULT
R1425 (591h)	AIF2 EQ Band 5 A	AIF2DAC_EQ_B5_A [15:0]																0564h
R1426 (592h)	AIF2 EQ Band 5 B	AIF2DAC_EQ_B5_B [15:0]																0559h
R1427 (593h)	AIF2 EQ Band 5 PG	AIF2DAC_EQ_B5_PG [15:0]																4000h
R1428 (594h)	AIF2 EQ Band 1 C	AIF2DAC_EQ_B1_C [15:0]																0000h
R1536 (600h)	DAC1 Mixer Volumes	0	0	0	0	0	0	0	ADCR_DAC1_VOL [3:0]			0	ADCL_DAC1_VOL [3:0]			0000h		
R1537 (601h)	DAC1 Left Mixer Routing	0	0	0	0	0	0	0	0	0	0	ADCR_TO_D AC1L	ADCL_TO_D AC1L	0	AIF2D O_DA C1L	0	AIF1D TO_D AC1L	0000h
R1538 (602h)	DAC1 Right Mixer Routing	0	0	0	0	0	0	0	0	0	0	ADCR_TO_D AC1R	ADCL_TO_D AC1R	0	AIF2D ACR_TO_D AC1R	0	AIF1D TO_D AC1R	0000h
R1539 (603h)	AIF2ADC Mixer Volumes	0	0	0	0	0	0	0	ADCR_AIF2ADC_VOL [3:0]			0	ADCL_AIF2ADC_VOL [3:0]			0000h		
R1540 (604h)	AIF2ADC Left Mixer Routing	0	0	0	0	0	0	0	0	0	0	ADCR_TO_A IF2AD CL	ADCL_TO_AI F2AD CL	0	AIF2D ACL_T O_AIF 2ADCL	0	AIF1D AC1L_TO_AI F2AD CL	0000h
R1541 (605h)	AIF2ADC Right Mixer Routing	0	0	0	0	0	0	0	0	0	0	ADCR_TO_A IF2AD CR	ADCL_TO_AI F2AD CR	0	AIF2D ACR_TO_AI F2AD CR	0	AIF1D AC1R_TO_AI F2AD CR	0000h
R1542 (606h)	AIF1 ADC1 Left Mixer Routing	0	0	0	0	0	0	0	0	0	0	0	0	0	0	ADC1L_TO_A IF1AD C1L	AIF2D ACL_T O_AIF 1ADC1 L	0000h
R1543 (607h)	AIF1 ADC1 Right Mixer Routing	0	0	0	0	0	0	0	0	0	0	0	0	0	0	ADC1R_TO_AIF1A DC1R	AIF2D ACR_TO_AI F1AD C1R	0000h
R1552 (610h)	DAC1 Left Volume	0	0	0	0	0	0	DAC1L_MUTE	DAC1_VU	DAC1L_VOL [7:0]							02C0h	
R1553 (611h)	DAC1 Right Volume	0	0	0	0	0	0	DAC1R_MUTE	DAC1_VU	DAC1R_VOL [7:0]							02C0h	
R1554 (612h)	AIF2TX Left Volume	0	0	0	0	0	0	AIF2TXL_MUTE	AIF2TX_X_VU	AIF2TXL_VOL [7:0]							02C0h	
R1555 (613h)	AIF2TX Right Volume	0	0	0	0	0	0	AIF2TXR_MUTE	AIF2TX_X_VU	AIF2TXR_VOL [7:0]							02C0h	
R1556 (614h)	DAC Softmute	0	0	0	0	0	0	0	0	0	0	0	0	0	0	DAC_SOFTMUTE MODE	DAC_MUTE RATE	0000h
R1568 (620h)	Oversampling	0	0	0	0	0	0	0	0	0	0	0	0	0	0	ADC_OSR1 28	DAC_OSR1 28	0002h
R1569 (621h)	Sidetone	0	0	0	0	0	0	ST_HPF_CUT [2:0]		ST_HPF	0	0	0	0	0	0	0	0000h

REG	NAME	15	14	13	12	11	10	9	8	7	6	5	4	3	2	1	0	DEFAULT
R1792 (700h)	GPIO 1	GP1_DIR	GP1_PU	GP1_PD	0	0	GP1_POL	GP1_OP_CFG	GP1_DB	0	GP1_LVL	0	GP1_FN [4:0]				8100h	
R1793 (701h)	Pull Control (MCLK2)	1	MCLK2_PU	MCLK2_PD	0	0	0	0	1	0	0	0	0	0	0	0	1	A101h
R1794 (702h)	Pull Control (BCLK2)	1	BCLK2_PU	BCLK2_PD	0	0	0	0	1	0	0	0	0	0	0	0	1	A101h
R1795 (703h)	Pull Control (DACLRCLK2)	1	DACL_RCLK2_PU	DACL_RCLK2_PD	0	0	0	0	1	0	0	0	0	0	0	0	1	A101h
R1796 (704h)	Pull Control (DACDAT2)	1	DACDAT2_PU	DACDAT2_PD	0	0	0	0	1	0	0	0	0	0	0	0	1	A101h
R1797 (705h)	JACKDET Ctrl	1	0	1	0	0	0	0	JACKDET_DB	0	JACKDET_LVL	0	0	0	0	0	1	A101h
R1799 (707h)	GPIO 8	GP8_DIR	GP8_PU	GP8_PD	0	0	GP8_POL	GP8_OP_CFG	GP8_DB	0	GP8_LVL	0	GP8_FN [4:0]				A101h	
R1800 (708h)	GPIO 9	GP9_DIR	GP9_PU	GP9_PD	0	0	GP9_POL	GP9_OP_CFG	GP9_DB	0	GP9_LVL	0	GP9_FN [4:0]				A101h	
R1801 (709h)	GPIO 10	GP10_DIR	GP10_PU	GP10_PD	0	0	GP10_POL	GP10_OP_CFG	GP10_DB	0	GP10_LVL	0	GP10_FN [4:0]				A101h	
R1802 (70Ah)	GPIO 11	GP11_DIR	GP11_PU	GP11_PD	0	0	GP11_POL	GP11_OP_CFG	GP11_DB	0	GP11_LVL	0	GP11_FN [4:0]				A101h	
R1824 (720h)	Pull Control (1)	0	0	0	0	0	0	DMICDAT1_PU	DMICDAT1_PD	MCLK1_PU	MCLK1_PD	DACDAT1_PU	DACDAT1_PD	DACL_RCLK1_PU	DACL_RCLK1_PD	BCLK1_PU	BCLK1_PD	0000h
R1825 (721h)	Pull Control (2)	0	0	0	0	0	0	0	ADDR_PD	0	LDO2_ENA_PD	0	LDO1_ENA_PD	0	1	SPKMODE_PU	0	0156h
R1840 (730h)	Interrupt Status 1	0	0	0	0	0	GP11_EINT	GP10_EINT	GP9_EINT	GP8_EINT	0	JACKDET_EINT	0	0	0	0	GP1_EINT	0000h
R1841 (731h)	Interrupt Status 2	TEMP_WARN_EINT	DCS_DONE_EINT	0	FIFOS_ERR_EINT	AIF2D_RC_SIG_DET_EINT	0	AIF1D_RC1_SIG_DET_EINT	SRC2_LOCK_EINT	SRC1_LOCK_EINT	FLL2_LOCK_EINT	FLL1_LOCK_EINT	0	0	0	MICD_EINT	TEMP_SHUT_EINT	0000h
R1842 (732h)	Interrupt Raw Status 2	TEMP_WARN_STS	DCS_DONE_STS	0	FIFOS_ERR_STS	AIF2D_RC_SIG_DET_STS	0	AIF1D_RC1_SIG_DET_STS	SRC2_LOCK_STS	SRC1_LOCK_STS	FLL2_LOCK_STS	FLL1_LOCK_STS	0	0	0	0	TEMP_SHUT_STS	0000h
R1848 (738h)	Interrupt Status 1 Mask	0	0	0	0	0	IM_GP11_EINT	IM_GP10_EINT	IM_GP9_EINT	IM_GP8_EINT	1	IM_JACKDET_EINT	1	1	1	1	IM_GP1_EINT	07FFh
R1849 (739h)	Interrupt Status 2 Mask	IM_TEMP_WARN_EINT	IM_DCS_DONE_EINT	0	IM_FIFOS_ERR_EINT	IM_AIF2D_RC_SIG_DET_EINT	0	IM_AIF1D_RC1_SIG_DET_EINT	IM_SRC2_LOCK_EINT	IM_SRC1_LOCK_EINT	IM_FLL2_LOCK_EINT	IM_FLL1_LOCK_EINT	0	1	1	IM_MICD_EINT	IM_TEMP_SHUT_EINT	DBEFh
R1856 (740h)	Interrupt Control	0	0	0	0	0	0	0	0	0	0	0	0	0	0	0	IM_IRQ	0000h

Production Data

**WM1811A**

REG	NAME	15	14	13	12	11	10	9	8	7	6	5	4	3	2	1	0	DEFAULT
R1864 (748h)	IRQ Debounce	0	0	0	0	0	0	0	0	0	0	TEMP _WAR N_DB	1	1	1	1	TEMP _SHU T_DB	003Fh

## REGISTER BITS BY ADDRESS

REGISTER ADDRESS	BIT	LABEL	DEFAULT	DESCRIPTION
R0 (00h) Software Reset	15:0	SW_RESET [15:0]	0001_1000_00 01_0001	Writing to this register resets all registers to their default state. Reading from this register will indicate device ID 1811h.

## Register 00h Software Reset

REGISTER ADDRESS	BIT	LABEL	DEFAULT	DESCRIPTION
R1 (01h) Power Management (1)	13	SPKOUTR_ENA	0	SPKMIXR Mixer, SPKRVOL PGA and SPKOUTR Output Enable 0 = Disabled 1 = Enabled
	12	SPKOUTL_ENA	0	SPKMIXL Mixer, SPKLVOL PGA and SPKOUTL Output Enable 0 = Disabled 1 = Enabled
	11	HPOUT2_ENA	0	HPOUT2 Output Stage Enable 0 = Disabled 1 = Enabled
	9	HPOUT1L_ENA	0	Enables HPOUT1L input stage 0 = Disabled 1 = Enabled For normal operation, this bit should be set as the first step of the HPOUT1L Enable sequence.
	8	HPOUT1R_ENA	0	Enables HPOUT1R input stage 0 = Disabled 1 = Enabled For normal operation, this bit should be set as the first step of the HPOUT1R Enable sequence.
	5	MICB2_ENA	0	Microphone Bias 2 Enable 0 = Disabled 1 = Enabled
	4	MICB1_ENA	0	Microphone Bias 1 Enable 0 = Disabled 1 = Enabled
	2:1	VMID_SEL [1:0]	00	VMID Divider Enable and Select 00 = VMID disabled (for OFF mode) 01 = 2 x 40k divider (for normal operation) 10 = 2 x 240k divider (for low power standby) 11 = Reserved
	0	BIAS_ENA	0	Enables the Normal bias current generator (for all analogue functions) 0 = Disabled 1 = Enabled

## Register 01h Power Management (1)

REGISTER ADDRESS	BIT	LABEL	DEFAULT	DESCRIPTION
R2 (02h) Power Management (2)	14	TSHUT_ENA	1	Thermal sensor enable 0 = Disabled 1 = Enabled
	13	TSHUT_OPDIS	1	Thermal shutdown control (Causes audio outputs to be disabled if an overtemperature occurs. The thermal sensor must also be enabled.) 0 = Disabled 1 = Enabled
	11	OPCLK_ENA	0	GPIO Clock Output (OPCLK) Enable 0 = Disabled 1 = Enabled
	9	MIXINL_ENA	0	Left Input Mixer Enable (Enables MIXINL and RXVOICE input to MIXINL) 0 = Disabled 1 = Enabled
	8	MIXINR_ENA	0	Right Input Mixer Enable (Enables MIXINR and RXVOICE input to MIXINR) 0 = Disabled 1 = Enabled
	7	IN2L_ENA	0	IN2L Input PGA Enable 0 = Disabled 1 = Enabled
	6	IN1L_ENA	0	IN1L Input PGA Enable 0 = Disabled 1 = Enabled
	5	IN2R_ENA	0	IN2R Input PGA Enable 0 = Disabled 1 = Enabled
	4	IN1R_ENA	0	IN1R Input PGA Enable 0 = Disabled 1 = Enabled

Register 02h Power Management (2)

REGISTER ADDRESS	BIT	LABEL	DEFAULT	DESCRIPTION
R3 (03h) Power Management (3)	13	LINEOUT1N_EN A	0	LINEOUT1N Line Out and LINEOUT1NMIX Enable 0 = Disabled 1 = Enabled
	12	LINEOUT1P_ENA	0	LINEOUT1P Line Out and LINEOUT1PMIX Enable 0 = Disabled 1 = Enabled
	11	LINEOUT2N_EN A	0	LINEOUT2N Line Out and LINEOUT2NMIX Enable 0 = Disabled 1 = Enabled
	10	LINEOUT2P_ENA	0	LINEOUT2P Line Out and LINEOUT2PMIX Enable 0 = Disabled 1 = Enabled

REGISTER ADDRESS	BIT	LABEL	DEFAULT	DESCRIPTION
	9	SPKRVOL_ENA	0	SPKMIXR Mixer and SPKRVOL PGA Enable 0 = Disabled 1 = Enabled Note that SPKMIXR and SPKRVOL are also enabled when SPKOUTR_ENA is set.
	8	SPKLVOL_ENA	0	SPKMIXL Mixer and SPKLVOL PGA Enable 0 = Disabled 1 = Enabled Note that SPKMIXL and SPKLVOL are also enabled when SPKOUTL_ENA is set.
	7	MIXOUTLVOL_ENA	0	MIXOUTL Left Volume Control Enable 0 = Disabled 1 = Enabled
	6	MIXOUTRVOL_ENA	0	MIXOUTR Right Volume Control Enable 0 = Disabled 1 = Enabled
	5	MIXOUTL_ENA	0	MIXOUTL Left Output Mixer Enable 0 = Disabled 1 = Enabled
	4	MIXOUTR_ENA	0	MIXOUTR Right Output Mixer Enable 0 = Disabled 1 = Enabled

Register 03h Power Management (3)

REGISTER ADDRESS	BIT	LABEL	DEFAULT	DESCRIPTION
R4 (04h) Power Management (4)	13	AIF2ADCL_ENA	0	Enable AIF2ADC (Left) output path 0 = Disabled 1 = Enabled This bit must be set for AIF2 or AIF3 output of the AIF2ADC (Left) signal.
	12	AIF2ADCR_ENA	0	Enable AIF2ADC (Right) output path 0 = Disabled 1 = Enabled This bit must be set for AIF2 or AIF3 output of the AIF2ADC (Left) signal.
	9	AIF1ADC1L_ENA	0	Enable AIF1ADC (Left) output path 0 = Disabled 1 = Enabled
	8	AIF1ADC1R_ENA	0	Enable AIF1ADC (Right) output path 0 = Disabled 1 = Enabled
	3	DMIC1L_ENA	0	Digital microphone (DMICDAT) Left channel enable 0 = Disabled 1 = Enabled
	2	DMIC1R_ENA	0	Digital microphone (DMICDAT) Right channel enable 0 = Disabled 1 = Enabled
	1	ADCL_ENA	0	Left ADC Enable 0 = Disabled 1 = Enabled



REGISTER ADDRESS	BIT	LABEL	DEFAULT	DESCRIPTION
	0	ADCR_ENA	0	Right ADC Enable 0 = Disabled 1 = Enabled

Register 04h Power Management (4)

REGISTER ADDRESS	BIT	LABEL	DEFAULT	DESCRIPTION
R5 (05h) Power Management (5)	13	AIF2DACL_ENA	0	Enable AIF2DAC (Left) input path 0 = Disabled 1 = Enabled
	12	AIF2DACR_ENA	0	Enable AIF2DAC (Right) input path 0 = Disabled 1 = Enabled
	9	AIF1DAC1L_ENA	0	Enable AIF1DAC (Left) input path 0 = Disabled 1 = Enabled
	8	AIF1DAC1R_ENA	0	Enable AIF1DAC (Right) input path 0 = Disabled 1 = Enabled
	1	DAC1L_ENA	0	Left DAC Enable 0 = Disabled 1 = Enabled
	0	DAC1R_ENA	0	Right DAC Enable 0 = Disabled 1 = Enabled

Register 05h Power Management (5)

REGISTER ADDRESS	BIT	LABEL	DEFAULT	DESCRIPTION
R6 (06h) Power Management (6)	10:9	AIF3ADC_SRC [1:0]	00	AIF3 Mono PCM output source select 00 = None 01 = AIF2ADC (Left) output path 10 = AIF2ADC (Right) output path 11 = Reserved
	8:7	AIF2DAC_SRC [1:0]	00	AIF2 input path select 00 = Left and Right inputs from AIF2 01 = Left input from AIF2; Right input from AIF3 10 = Left input from AIF3; Right input from AIF2 11 = Reserved
	5	AIF3_TRI	0	AIF3 Audio Interface tri-state 0 = AIF3 pins operate normally 1 = Tri-state all AIF3 interface pins Note that pins not configured as AIF3 functions are not affected by this register.
	4:3	AIF3_ADCCDAT_S RC [1:0]	00	GPIO9/ADCCDAT3 Source select 00 = AIF1 ADCCDAT1 01 = AIF2 ADCCDAT2 10 = DACDAT2 11 = AIF3 Mono PCM output Note that GPIO9 must be configured as ADCCDAT3.

REGISTER ADDRESS	BIT	LABEL	DEFAULT	DESCRIPTION
	2	AIF2_ADCCDAT_S RC	0	ADCCDAT2 Source select 0 = AIF2 ADCCDAT2 1 = GPIO8/DACDAT3 For selection 1, the GPIO8 pin must also be configured as DACDAT3.
	1	AIF2_DACDAT_S RC	0	AIF2 DACDAT Source select 0 = DACDAT2 1 = GPIO8/DACDAT3 For selection 1, the GPIO8 pin must also be configured as DACDAT3.
	0	AIF1_DACDAT_S RC	0	AIF1 DACDAT Source select 0 = DACDAT1 1 = GPIO8/DACDAT3 Note that, for selection 1, the GPIO8 pin must be configured as DACDAT3.

Register 06h Power Management (6)

REGISTER ADDRESS	BIT	LABEL	DEFAULT	DESCRIPTION
R21 (15h) Input Mixer (1)	8	IN1RP_MIXINR_ BOOST	0	IN1RP Pin (PGA Bypass) to MIXINR Gain Boost. This bit selects the maximum gain setting of the IN1RP_MIXINR_VOL register. 0 = Maximum gain is +6dB 1 = Maximum gain is +15dB
	7	IN1LP_MIXINL_ BOOST	0	IN1LP Pin (PGA Bypass) to MIXINL Gain Boost. This bit selects the maximum gain setting of the IN1LP_MIXINL_VOL register. 0 = Maximum gain is +6dB 1 = Maximum gain is +15dB
	6	INPUTS_CLAMP	0	Input pad VMID clamp 0 = Clamp de-activated 1 = Clamp activated

Register 15h Input Mixer (1)

REGISTER ADDRESS	BIT	LABEL	DEFAULT	DESCRIPTION
R24 (18h) Left Line Input 1&2 Volume	8	IN1_VU	0	Input PGA Volume Update Writing a 1 to this bit will cause IN1L and IN1R input PGA volumes to be updated simultaneously
	7	IN1L_MUTE	1	IN1L PGA Mute 0 = Disable Mute 1 = Enable Mute
	6	IN1L_ZC	0	IN1L PGA Zero Cross Detector 0 = Change gain immediately 1 = Change gain on zero cross only
	4:0	IN1L_VOL [4:0]	0_1011	IN1L Volume -16.5dB to +30dB in 1.5dB steps

Register 18h Left Line Input 1&amp;2 Volume

REGISTER ADDRESS	BIT	LABEL	DEFAULT	DESCRIPTION
R25 (19h) Left Line Input 3&4 Volume	8	IN2_VU	0	Input PGA Volume Update Writing a 1 to this bit will cause IN2L and IN2R input PGA volumes to be updated simultaneously
	7	IN2L_MUTE	1	IN2L PGA Mute 0 = Disable Mute 1 = Enable Mute
	6	IN2L_ZC	0	IN2L PGA Zero Cross Detector 0 = Change gain immediately 1 = Change gain on zero cross only
	4:0	IN2L_VOL [4:0]	0_1011	IN2L Volume -16.5dB to +30dB in 1.5dB steps

Register 19h Left Line Input 3&amp;4 Volume

REGISTER ADDRESS	BIT	LABEL	DEFAULT	DESCRIPTION
R26 (1Ah) Right Line Input 1&2 Volume	8	IN1_VU	0	Input PGA Volume Update Writing a 1 to this bit will cause IN1L and IN1R input PGA volumes to be updated simultaneously
	7	IN1R_MUTE	1	IN1R PGA Mute 0 = Disable Mute 1 = Enable Mute
	6	IN1R_ZC	0	IN1R PGA Zero Cross Detector 0 = Change gain immediately 1 = Change gain on zero cross only
	4:0	IN1R_VOL [4:0]	0_1011	IN1R Volume -16.5dB to +30dB in 1.5dB steps

Register 1Ah Right Line Input 1&amp;2 Volume

REGISTER ADDRESS	BIT	LABEL	DEFAULT	DESCRIPTION
R27 (1Bh) Right Line Input 3&4 Volume	8	IN2_VU	0	Input PGA Volume Update Writing a 1 to this bit will cause IN2L and IN2R input PGA volumes to be updated simultaneously
	7	IN2R_MUTE	1	IN2R PGA Mute 0 = Disable Mute 1 = Enable Mute
	6	IN2R_ZC	0	IN2R PGA Zero Cross Detector 0 = Change gain immediately 1 = Change gain on zero cross only
	4:0	IN2R_VOL [4:0]	0_1011	IN2R Volume -16.5dB to +30dB in 1.5dB steps

Register 1Bh Right Line Input 3&amp;4 Volume

REGISTER ADDRESS	BIT	LABEL	DEFAULT	DESCRIPTION
R28 (1Ch) Left Output Volume	8	HPOUT1_VU	0	Headphone Output PGA Volume Update Writing a 1 to this bit will update HPOUT1LVOL and HPOUT1RVOL volumes simultaneously.
	7	HPOUT1L_ZC	0	HPOUT1LVOL (Left Headphone Output PGA) Zero Cross Enable 0 = Zero cross disabled 1 = Zero cross enabled
	6	HPOUT1L_MUTE_N	1	HPOUT1LVOL (Left Headphone Output PGA) Mute 0 = Mute 1 = Un-mute
	5:0	HPOUT1L_VOL [5:0]	10_1101	HPOUT1LVOL (Left Headphone Output PGA) Volume -57dB to +6dB in 1dB steps 00_0000 = -57dB 00_0001 = -56dB ... (1dB steps) 11_1111 = +6dB

Register 1Ch Left Output Volume

REGISTER ADDRESS	BIT	LABEL	DEFAULT	DESCRIPTION
R29 (1Dh) Right Output Volume	8	HPOUT1_VU	0	Headphone Output PGA Volume Update Writing a 1 to this bit will update HPOUT1LVOL and HPOUT1RVOL volumes simultaneously.
	7	HPOUT1R_ZC	0	HPOUT1RVOL (Right Headphone Output PGA) Zero Cross Enable 0 = Zero cross disabled 1 = Zero cross enabled
	6	HPOUT1R_MUTE_N	1	HPOUT1RVOL (Right Headphone Output PGA) Mute 0 = Mute 1 = Un-mute
	5:0	HPOUT1R_VOL [5:0]	10_1101	HPOUT1RVOL (Right Headphone Output PGA) Volume -57dB to +6dB in 1dB steps 00_0000 = -57dB 00_0001 = -56dB ... (1dB steps) 11_1111 = +6dB

Register 1Dh Right Output Volume

REGISTER ADDRESS	BIT	LABEL	DEFAULT	DESCRIPTION
R30 (1Eh) Line Outputs Volume	6	LINEOUT1N_MUTE	1	LINEOUT1N Line Output Mute 0 = Un-mute 1 = Mute
	5	LINEOUT1P_MUTE	1	LINEOUT1P Line Output Mute 0 = Un-mute 1 = Mute
	4	LINEOUT1_VOL	0	LINEOUT1 Line Output Volume 0 = 0dB 1 = -6dB Applies to both LINEOUT1N and LINEOUT1P

REGISTER ADDRESS	BIT	LABEL	DEFAULT	DESCRIPTION
	2	LINEOUT2N_MUTE	1	LINEOUT2N Line Output Mute 0 = Un-mute 1 = Mute
	1	LINEOUT2P_MUTE	1	LINEOUT2P Line Output Mute 0 = Un-mute 1 = Mute
	0	LINEOUT2_VOL	0	LINEOUT2 Line Output Volume 0 = 0dB 1 = -6dB Applies to both LINEOUT2N and LINEOUT2P

Register 1Eh Line Outputs Volume

REGISTER ADDRESS	BIT	LABEL	DEFAULT	DESCRIPTION
R31 (1Fh) HPOUT2 Volume	5	HPOUT2_MUTE	1	HPOUT2 (Earpiece Driver) Mute 0 = Mute 1 = Un-mute
	4	HPOUT2_VOL	0	HPOUT2 (Earpiece Driver) Volume 0 = 0dB 1 = -6dB

Register 1Fh HPOUT2 Volume

REGISTER ADDRESS	BIT	LABEL	DEFAULT	DESCRIPTION
R32 (20h) Left OPGA Volume	8	MIXOUT_VU	0	Mixer Output PGA Volume Update Writing a 1 to this bit will update MIXOUTLVOL and MIXOUTRVOL volumes simultaneously.
	7	MIXOUTL_ZC	0	MIXOUTLVOL (Left Mixer Output PGA) Zero Cross Enable 0 = Zero cross disabled 1 = Zero cross enabled
	6	MIXOUTL_MUTE_N	1	MIXOUTLVOL (Left Mixer Output PGA) Mute 0 = Mute 1 = Un-mute
	5:0	MIXOUTL_VOL [5:0]	11_1001	MIXOUTLVOL (Left Mixer Output PGA) Volume -57dB to +6dB in 1dB steps 00_0000 = -57dB 00_0001 = -56dB ... (1dB steps) 11_1111 = +6dB

Register 20h Left OPGA Volume

REGISTER ADDRESS	BIT	LABEL	DEFAULT	DESCRIPTION
R33 (21h) Right OPGA Volume	8	MIXOUT_VU	0	Mixer Output PGA Volume Update Writing a 1 to this bit will update MIXOUTLVOL and MIXOUTRVOL volumes simultaneously.
	7	MIXOUTR_ZC	0	MIXOUTRVOL (Right Mixer Output PGA) Zero Cross Enable 0 = Zero cross disabled 1 = Zero cross enabled
	6	MIXOUTR_MUTE_N	1	MIXOUTLVOL (Right Mixer Output PGA) Mute 0 = Mute 1 = Un-mute
	5:0	MIXOUTR_VOL [5:0]	11_1001	MIXOUTRVOL (Right Mixer Output PGA) Volume -57dB to +6dB in 1dB steps 00_0000 = -57dB 00_0001 = -56dB ... (1dB steps) 11_1111 = +6dB

Register 21h Right OPGA Volume

REGISTER ADDRESS	BIT	LABEL	DEFAULT	DESCRIPTION
R34 (22h) SPKMIXL Attenuation	5	MIXINL_SPKMIXL_VOL	0	MIXINL (Left ADC bypass) to SPKMIXL Fine Volume Control 0 = 0dB 1 = -6dB
	4	IN1LP_SPKMIXL_VOL	0	IN1LP to SPKMIXL Fine Volume Control 0 = 0dB 1 = -6dB
	3	MIXOUTL_SPKMIXL_VOL	0	Left Mixer Output to SPKMIXL Fine Volume Control 0 = 0dB 1 = -6dB
	2	DAC1L_SPKMIXL_VOL	0	Left DAC to SPKMIXL Fine Volume Control 0 = 0dB 1 = -6dB
	1:0	SPKMIXL_VOL [1:0]	11	Left Speaker Mixer Volume Control 00 = 0dB 01 = Reserved 10 = Reserved 11 = Mute

Register 22h SPKMIXL Attenuation

REGISTER ADDRESS	BIT	LABEL	DEFAULT	DESCRIPTION
R35 (23h) SPKMIXR Attenuation	5	MIXINR_SPKMIXR_VOL	0	MIXINR (Right ADC bypass) to SPKMIXR Fine Volume Control 0 = 0dB 1 = -6dB
	4	IN1RP_SPKMIXR_VOL	0	IN1RP to SPKMIXR Fine Volume Control 0 = 0dB 1 = -6dB
	3	MIXOUTR_SPKMIXR_VOL	0	Right Mixer Output to SPKMIXR Fine Volume Control 0 = 0dB 1 = -6dB

REGISTER ADDRESS	BIT	LABEL	DEFAULT	DESCRIPTION
	2	DAC1R_SPKMIXR_VOL	0	Right DAC to SPKMIXR Fine Volume Control 0 = 0dB 1 = -6dB
	1:0	SPKMIXR_VOL [1:0]	11	Right Speaker Mixer Volume Control 00 = 0dB 01 = Reserved 10 = Reserved 11 = Mute

Register 23h SPKMIXR Attenuation

REGISTER ADDRESS	BIT	LABEL	DEFAULT	DESCRIPTION
R36 (24h) SPKOUT Mixers	4	SPKMIXL_TO_SPKOUTL	1	SPKMIXL Left Speaker Mixer to Left Speaker Mute 0 = Mute 1 = Un-mute
	3	SPKMIXR_TO_SPKOUTL	0	SPKMIXR Right Speaker Mixer to Left Speaker Mute 0 = Mute 1 = Un-mute
	1	SPKMIXL_TO_SPKOUTR	0	SPKMIXL Left Speaker Mixer to Right Speaker Mute 0 = Mute 1 = Un-mute
	0	SPKMIXR_TO_SPKOUTR	1	SPKMIXR Right Speaker Mixer to Right Speaker Mute 0 = Mute 1 = Un-mute

Register 24h SPKOUT Mixers

REGISTER ADDRESS	BIT	LABEL	DEFAULT	DESCRIPTION
R37 (25h) ClassD	6	Reserved	1	Reserved - do not change
	5:3	SPKOUTL_BOOST [2:0]	000	Left Speaker Gain Boost 000 = 1.00x boost (+0dB) 001 = 1.19x boost (+1.5dB) 010 = 1.41x boost (+3.0dB) 011 = 1.68x boost (+4.5dB) 100 = 2.00x boost (+6.0dB) 101 = 2.37x boost (+7.5dB) 110 = 2.81x boost (+9.0dB) 111 = 3.98x boost (+12.0dB)
	2:0	SPKOUTR_BOOST [2:0]	000	Right Speaker Gain Boost 000 = 1.00x boost (+0dB) 001 = 1.19x boost (+1.5dB) 010 = 1.41x boost (+3.0dB) 011 = 1.68x boost (+4.5dB) 100 = 2.00x boost (+6.0dB) 101 = 2.37x boost (+7.5dB) 110 = 2.81x boost (+9.0dB) 111 = 3.98x boost (+12.0dB)

Register 25h ClassD

REGISTER ADDRESS	BIT	LABEL	DEFAULT	DESCRIPTION
R38 (26h) Speaker Volume Left	8	SPKOUT_VU	0	Speaker Output PGA Volume Update Writing a 1 to this bit will update SPKLVOL and SPKRVOL volumes simultaneously.
	7	SPKOUTL_ZC	0	SPKLVOL (Left Speaker Output PGA) Zero Cross Enable 0 = Zero cross disabled 1 = Zero cross enabled
	6	SPKOUTL_MUTE_N	1	SPKLVOL (Left Speaker Output PGA) Mute 0 = Mute 1 = Un-mute
	5:0	SPKOUTL_VOL [5:0]	11_1001	SPKLVOL (Left Speaker Output PGA) Volume -57dB to +6dB in 1dB steps 00_0000 = -57dB 00_0001 = -56dB ... (1dB steps) 11_1111 = +6dB

Register 26h Speaker Volume Left

REGISTER ADDRESS	BIT	LABEL	DEFAULT	DESCRIPTION
R39 (27h) Speaker Volume Right	8	SPKOUT_VU	0	Speaker Output PGA Volume Update Writing a 1 to this bit will update SPKLVOL and SPKRVOL volumes simultaneously.
	7	SPKOUTR_ZC	0	SPKRVOL (Right Speaker Output PGA) Zero Cross Enable 0 = Zero cross disabled 1 = Zero cross enabled
	6	SPKOUTR_MUTE_N	1	SPKRVOL (Right Speaker Output PGA) Mute 0 = Mute 1 = Un-mute
	5:0	SPKOUTR_VOL [5:0]	11_1001	SPKRVOL (Right Speaker Output PGA) Volume -57dB to +6dB in 1dB steps 00_0000 = -57dB 00_0001 = -56dB ... (1dB steps) 11_1111 = +6dB

Register 27h Speaker Volume Right

REGISTER ADDRESS	BIT	LABEL	DEFAULT	DESCRIPTION
R40 (28h) Input Mixer (2)	7	IN2LP_TO_IN2L	0	IN2L PGA Non-Inverting Input Select 0 = Connected to VMID 1 = Connected to IN2LP Note that VMID_BUF_ENA must be set when using IN2L connected to VMID.
	6	IN2LN_TO_IN2L	0	IN2L PGA Inverting Input Select 0 = Not connected 1 = Connected to IN2LN
	5	IN1LP_TO_IN1L	0	IN1L PGA Non-Inverting Input Select 0 = Connected to VMID 1 = Connected to IN1LP Note that VMID_BUF_ENA must be set when using IN1L connected to VMID.
	4	IN1LN_TO_IN1L	0	IN1L PGA Inverting Input Select



REGISTER ADDRESS	BIT	LABEL	DEFAULT	DESCRIPTION
				0 = Not connected 1 = Connected to IN1LN
	3	IN2RP_TO_IN2R	0	IN2R PGA Non-Inverting Input Select 0 = Connected to VMID 1 = Connected to IN2RP Note that VMID_BUF_ENA must be set when using IN2R connected to VMID.
	2	IN2RN_TO_IN2R	0	IN2R PGA Inverting Input Select 0 = Not connected 1 = Connected to IN2RN
	1	IN1RP_TO_IN1R	0	IN1R PGA Non-Inverting Input Select 0 = Connected to VMID 1 = Connected to IN1RP Note that VMID_BUF_ENA must be set when using IN1R connected to VMID.
	0	IN1RN_TO_IN1R	0	IN1R PGA Inverting Input Select 0 = Not connected 1 = Connected to IN1RN

Register 28h Input Mixer (2)

REGISTER ADDRESS	BIT	LABEL	DEFAULT	DESCRIPTION
R41 (29h) Input Mixer (3)	8	IN2L_TO_MIXINL	0	IN2L PGA Output to MIXINL Mute 0 = Mute 1 = Un-Mute
	7	IN2L_MIXINL_VOL	0	IN2L PGA Output to MIXINL Gain 0 = 0dB 1 = +30dB
	5	IN1L_TO_MIXINL	0	IN1L PGA Output to MIXINL Mute 0 = Mute 1 = Un-Mute
	4	IN1L_MIXINL_VOL	0	IN1L PGA Output to MIXINL Gain 0 = 0dB 1 = +30dB
	2:0	MIXOUTL_MIXINL_VOL [2:0]	000	Record Path MIXOUTL to MIXINL Gain and Mute 000 = Mute 001 = -12dB 010 = -9dB 011 = -6dB 100 = -3dB 101 = 0dB 110 = +3dB 111 = +6dB

Register 29h Input Mixer (3)

REGISTER ADDRESS	BIT	LABEL	DEFAULT	DESCRIPTION
R42 (2Ah) Input Mixer (4)	8	IN2R_TO_MIXINR	0	IN2R PGA Output to MIXINR Mute 0 = Mute 1 = Un-Mute
	7	IN2R_MIXINR_VOL	0	IN2R PGA Output to MIXINR Gain 0 = 0dB 1 = +30dB
	5	IN1R_TO_MIXINR	0	IN1R PGA Output to MIXINR Mute 0 = Mute 1 = Un-Mute
	4	IN1R_MIXINR_VOL	0	IN1R PGA Output to MIXINR Gain 0 = 0dB 1 = +30dB
	2:0	MIXOUTR_MIXINR_VOL [2:0]	000	Record Path MIXOUTR to MIXINR Gain and Mute 000 = Mute 001 = -12dB 010 = -9dB 011 = -6dB 100 = -3dB 101 = 0dB 110 = +3dB 111 = +6dB

Register 2Ah Input Mixer (4)

REGISTER ADDRESS	BIT	LABEL	DEFAULT	DESCRIPTION
R43 (2Bh) Input Mixer (5)	8:6	IN1LP_MIXINL_VOL [2:0]	000	IN1LP Pin (PGA Bypass) to MIXINL Gain and Mute 000 = Mute 001 = -12dB 010 = -9dB 011 = -6dB 100 = -3dB 101 = 0dB 110 = +3dB 111 = +6dB (see note below). When IN1LP_MIXINL_BOOST is set, then the maximum gain setting is increased to +15dB, ie. 111 = +15dB. Note that VMID_BUF_ENA must be set when using the IN1LP (PGA Bypass) input to MIXINL.
	2:0	IN2LRP_MIXINL_VOL [2:0]	000	RXVOICE Differential Input (VRXP-VRXN) to MIXINL Gain and Mute 000 = Mute 001 = -12dB 010 = -9dB 011 = -6dB 100 = -3dB 101 = 0dB 110 = +3dB 111 = +6dB

Register 2Bh Input Mixer (5)

REGISTER ADDRESS	BIT	LABEL	DEFAULT	DESCRIPTION
R44 (2Ch) Input Mixer (6)	8:6	IN1RP_MIXINR_VOL [2:0]	000	IN1RP Pin (PGA Bypass) to MIXINR Gain and Mute 000 = Mute 001 = -12dB 010 = -9dB 011 = -6dB 100 = -3dB 101 = 0dB 110 = +3dB 111 = +6dB (see note below). When IN1RP_MIXINR_BOOST is set, then the maximum gain setting is increased to +15dB, ie. 111 = +15dB. Note that VMID_BUF_ENA must be set when using the IN1RP (PGA Bypass) input to MIXINR.
	2:0	IN2LRP_MIXINR_VOL [2:0]	000	RXVOICE Differential Input (VRXP-VRXN) to MIXINR Gain and Mute 000 = Mute 001 = -12dB 010 = -9dB 011 = -6dB 100 = -3dB 101 = 0dB 110 = +3dB 111 = +6dB

Register 2Ch Input Mixer (6)

REGISTER ADDRESS	BIT	LABEL	DEFAULT	DESCRIPTION
R45 (2Dh) Output Mixer (1)	8	DAC1L_TO_HPOUT1L	0	HPOUT1LVOL (Left Headphone Output PGA) Input Select 0 = MIXOUTL 1 = DACL
	7	MIXINR_TO_MIXOUTL	0	MIXINR Output (Right ADC bypass) to MIXOUTL Mute 0 = Mute 1 = Un-mute
	6	MIXINL_TO_MIXOUTL	0	MIXINL Output (Left ADC bypass) to MIXOUTL Mute 0 = Mute 1 = Un-mute
	5	IN2RN_TO_MIXOUTL	0	IN2RN to MIXOUTL Mute 0 = Mute 1 = Un-mute Note that VMID_BUF_ENA must be set when using the IN2RN input to MIXOUTL.
	4	IN2LN_TO_MIXOUTL	0	IN2LN to MIXOUTL Mute 0 = Mute 1 = Un-mute Note that VMID_BUF_ENA must be set when using the IN2LN input to MIXOUTL.
	3	IN1R_TO_MIXOUTL	0	IN1R PGA Output to MIXOUTL Mute 0 = Mute 1 = Un-mute
	2	IN1L_TO_MIXOUTL	0	IN1L PGA Output to MIXOUTL Mute 0 = Mute 1 = Un-mute

REGISTER ADDRESS	BIT	LABEL	DEFAULT	DESCRIPTION
	1	IN2LP_TO_MIXOUTL	0	IN2LP to MIXOUTL Mute 0 = Mute 1 = Un-mute Note that VMID_BUF_ENA must be set when using the IN2LP input to MIXOUTL.
	0	DAC1L_TO_MIXOUTL	0	Left DAC to MIXOUTL Mute 0 = Mute 1 = Un-mute

Register 2Dh Output Mixer (1)

REGISTER ADDRESS	BIT	LABEL	DEFAULT	DESCRIPTION
R46 (2Eh) Output Mixer (2)	8	DAC1R_TO_HPOUT1R	0	HPOUT1RVOL (Right Headphone Output PGA) Input Select 0 = MIXOUTR 1 = DACR
	7	MIXINL_TO_MIXOUTR	0	MIXINL Output (Left ADC bypass) to MIXOUTR Mute 0 = Mute 1 = Un-mute
	6	MIXINR_TO_MIXOUTR	0	MIXINR Output (Right ADC bypass) to MIXOUTR Mute 0 = Mute 1 = Un-mute
	5	IN2LN_TO_MIXOUTR	0	IN2LN to MIXOUTR Mute 0 = Mute 1 = Un-mute Note that VMID_BUF_ENA must be set when using the IN2LN input to MIXOUTR.
	4	IN2RN_TO_MIXOUTR	0	IN2RN to MIXOUTR Mute 0 = Mute 1 = Un-mute Note that VMID_BUF_ENA must be set when using the IN2RN input to MIXOUTR.
	3	IN1L_TO_MIXOUTR	0	IN1L PGA Output to MIXOUTR Mute 0 = Mute 1 = Un-mute
	2	IN1R_TO_MIXOUTR	0	IN1R PGA Output to MIXOUTR Mute 0 = Mute 1 = Un-mute
	1	IN2RP_TO_MIXOUTR	0	IN2RP to MIXOUTR Mute 0 = Mute 1 = Un-mute Note that VMID_BUF_ENA must be set when using the IN2RP input to MIXOUTR.
	0	DAC1R_TO_MIXOUTR	0	Right DAC to MIXOUTR Mute 0 = Mute 1 = Un-mute

Register 2Eh Output Mixer (2)

REGISTER ADDRESS	BIT	LABEL	DEFAULT	DESCRIPTION
R47 (2Fh) Output Mixer (3)	11:9	IN2LP_MIXOUTL_VOL [2:0]	000	IN2LP to MIXOUTL Volume 0dB to -9dB in 3dB steps X00 = 0dB X01 = -3dB X10 = -6dB X11 = -9dB
	8:6	IN2LN_MIXOUTL_VOL [2:0]	000	IN2LN to MIXOUTL Volume 0dB to -9dB in 3dB steps X00 = 0dB X01 = -3dB X10 = -6dB X11 = -9dB
	5:3	IN1R_MIXOUTL_VOL [2:0]	000	IN1R PGA Output to MIXOUTL Volume 0dB to -9dB in 3dB steps X00 = 0dB X01 = -3dB X10 = -6dB X11 = -9dB
	2:0	IN1L_MIXOUTL_VOL [2:0]	000	IN1L PGA Output to MIXOUTL Volume 0dB to -9dB in 3dB steps X00 = 0dB X01 = -3dB X10 = -6dB X11 = -9dB

Register 2Fh Output Mixer (3)

REGISTER ADDRESS	BIT	LABEL	DEFAULT	DESCRIPTION
R48 (30h) Output Mixer (4)	11:9	IN2RP_MIXOUTR_VOL [2:0]	000	IN2RP to MIXOUTR Volume 0dB to -9dB in 3dB steps X00 = 0dB X01 = -3dB X10 = -6dB X11 = -9dB
	8:6	IN2RN_MIXOUTR_VOL [2:0]	000	IN2RN to MIXOUTR Volume 0dB to -9dB in 3dB steps X00 = 0dB X01 = -3dB X10 = -6dB X11 = -9dB
	5:3	IN1L_MIXOUTR_VOL [2:0]	000	IN1L PGA Output to MIXOUTR Volume 0dB to -9dB in 3dB steps X00 = 0dB X01 = -3dB X10 = -6dB X11 = -9dB

REGISTER ADDRESS	BIT	LABEL	DEFAULT	DESCRIPTION
	2:0	IN1R_MIXOUTR_VOL [2:0]	000	IN1R PGA Output to MIXOUTR Volume 0dB to -9dB in 3dB steps X00 = 0dB X01 = -3dB X10 = -6dB X11 = -9dB

Register 30h Output Mixer (4)

REGISTER ADDRESS	BIT	LABEL	DEFAULT	DESCRIPTION
R49 (31h) Output Mixer (5)	11:9	DAC1L_MIXOUTL_VOL [2:0]	000	Left DAC to MIXOUTL Volume 0dB to -9dB in 3dB steps X00 = 0dB X01 = -3dB X10 = -6dB X11 = -9dB
	8:6	IN2RN_MIXOUTL_VOL [2:0]	000	IN2RN to MIXOUTL Volume 0dB to -9dB in 3dB steps X00 = 0dB X01 = -3dB X10 = -6dB X11 = -9dB
	5:3	MIXINR_MIXOUTL_VOL [2:0]	000	MIXINR Output (Right ADC bypass) to MIXOUTL Volume 0dB to -9dB in 3dB steps X00 = 0dB X01 = -3dB X10 = -6dB X11 = -9dB
	2:0	MIXINL_MIXOUTL_VOL [2:0]	000	MIXINL Output (Left ADC bypass) to MIXOUTL Volume 0dB to -9dB in 3dB steps X00 = 0dB X01 = -3dB X10 = -6dB X11 = -9dB

Register 31h Output Mixer (5)

REGISTER ADDRESS	BIT	LABEL	DEFAULT	DESCRIPTION
R50 (32h) Output Mixer (6)	11:9	DAC1R_MIXOUTR_VOL [2:0]	000	Right DAC to MIXOUTR Volume 0dB to -9dB in 3dB steps X00 = 0dB X01 = -3dB X10 = -6dB X11 = -9dB
	8:6	IN2LN_MIXOUTR_VOL [2:0]	000	IN2LN to MIXOUTR Volume 0dB to -9dB in 3dB steps X00 = 0dB X01 = -3dB X10 = -6dB X11 = -9dB

REGISTER ADDRESS	BIT	LABEL	DEFAULT	DESCRIPTION
	5:3	MIXINL_MIXOUT_R_VOL [2:0]	000	MIXINL Output (Left ADC bypass) to MIXOUTR Volume 0dB to -9dB in 3dB steps X00 = 0dB X01 = -3dB X10 = -6dB X11 = -9dB
	2:0	MIXINR_MIXOUT_R_VOL [2:0]	000	MIXINR Output (Right ADC bypass) to MIXOUTR Volume 0dB to -9dB in 3dB steps X00 = 0dB X01 = -3dB X10 = -6dB X11 = -9dB

Register 32h Output Mixer (6)

REGISTER ADDRESS	BIT	LABEL	DEFAULT	DESCRIPTION
R51 (33h) HPOUT2 Mixer	4	MIXOUTLVOL_T O_HPOUT2	0	MIXOUTLVOL (Left Output Mixer PGA) to Earpiece Driver 0 = Mute 1 = Un-mute
	3	MIXOUTRVOL_T O_HPOUT2	0	MIXOUTRVOL (Right Output Mixer PGA) to Earpiece Driver 0 = Mute 1 = Un-mute

Register 33h HPOUT2 Mixer

REGISTER ADDRESS	BIT	LABEL	DEFAULT	DESCRIPTION
R52 (34h) Line Mixer (1)	6	MIXOUTL_TO_LI NEOUT1N	0	MIXOUTL to Single-Ended Line Output on LINEOUT1N 0 = Mute 1 = Un-mute (LINEOUT1_MODE = 1)
	5	MIXOUTR_TO_LI NEOUT1N	0	MIXOUTR to Single-Ended Line Output on LINEOUT1N 0 = Mute 1 = Un-mute (LINEOUT1_MODE = 1)
	4	LINEOUT1_MODE	0	LINEOUT1 Mode Select 0 = Differential 1 = Single-Ended
	2	IN1R_TO_LINEO UT1P	0	IN1R Input PGA to Differential Line Output on LINEOUT1 0 = Mute 1 = Un-mute (LINEOUT1_MODE = 0)
	1	IN1L_TO_LINEO UT1P	0	IN1L Input PGA to Differential Line Output on LINEOUT1 0 = Mute 1 = Un-mute (LINEOUT1_MODE = 0)
	0	MIXOUTL_TO_LI NEOUT1P	0	Differential Mode (LINEOUT1_MODE = 0): MIXOUTL to Differential Output on LINEOUT1 0 = Mute 1 = Un-mute

REGISTER ADDRESS	BIT	LABEL	DEFAULT	DESCRIPTION
				Single Ended Mode (LINEOUT1_MODE = 1): MIXOUTL to Single-Ended Line Output on LINEOUT1P 0 = Mute 1 = Un-mute

Register 34h Line Mixer (1)

REGISTER ADDRESS	BIT	LABEL	DEFAULT	DESCRIPTION
R53 (35h) Line Mixer (2)	6	MIXOUTR_TO_LI NEOUT2N	0	MIXOUTR to Single-Ended Line Output on LINEOUT2N 0 = Mute 1 = Un-mute (LINEOUT2_MODE = 1)
	5	MIXOUTL_TO_LI NEOUT2N	0	MIXOUTL to Single-Ended Line Output on LINEOUT2N 0 = Mute 1 = Un-mute (LINEOUT2_MODE = 1)
	4	LINEOUT2_MOD E	0	LINEOUT2 Mode Select 0 = Differential 1 = Single-Ended
	2	IN1L_TO_LINEO UT2P	0	IN1L Input PGA to Differential Line Output on LINEOUT2 0 = Mute 1 = Un-mute (LINEOUT2_MODE = 0)
	1	IN1R_TO_LINEO UT2P	0	IN1R Input PGA to Differential Line Output on LINEOUT2 0 = Mute 1 = Un-mute (LINEOUT2_MODE = 0)
	0	MIXOUTR_TO_LI NEOUT2P	0	Differential Mode (LINEOUT2_MODE = 0): MIXOUTR to Differential Output on LINEOUT2 0 = Mute 1 = Un-mute  Single-Ended Mode (LINEOUT2_MODE = 0): MIXOUTR to Single-Ended Line Output on LINEOUT2P 0 = Mute 1 = Un-mute

Register 35h Line Mixer (2)

REGISTER ADDRESS	BIT	LABEL	DEFAULT	DESCRIPTION
R54 (36h) Speaker Mixer	7	MIXINL_TO_SPK MIXL	0	MIXINL (Left ADC bypass) to SPKMIXL Mute 0 = Mute 1 = Un-mute
	6	MIXINR_TO_SPK MIXR	0	MIXINR (Right ADC bypass) to SPKMIXR Mute 0 = Mute 1 = Un-mute
	5	IN1LP_TO_SPKM IXL	0	IN1LP to SPKMIXL Mute 0 = Mute



REGISTER ADDRESS	BIT	LABEL	DEFAULT	DESCRIPTION
				1 = Un-mute Note that VMID_BUF_ENA must be set when using the IN1LP input to SPKMIXL.
	4	IN1RP_TO_SPK MIXR	0	IN1RP to SPKMIXR Mute 0 = Mute 1 = Un-mute Note that VMID_BUF_ENA must be set when using the IN1RP input to SPKMIXR.
	3	MIXOUTL_TO_S PKMIXL	0	Left Mixer Output to SPKMIXL Mute 0 = Mute 1 = Un-mute
	2	MIXOUTR_TO_S PKMIXR	0	Right Mixer Output to SPKMIXR Mute 0 = Mute 1 = Un-mute
	1	DAC1L_TO_SPK MIXL	0	Left DAC to SPKMIXL Mute 0 = Mute 1 = Un-mute
	0	DAC1R_TO_SPK MIXR	0	Right DAC to SPKMIXR Mute 0 = Mute 1 = Un-mute

Register 36h Speaker Mixer

REGISTER ADDRESS	BIT	LABEL	DEFAULT	DESCRIPTION
R55 (37h) Additional Control	7	LINEOUT1_FB	0	Enable ground loop noise feedback on LINEOUT1 0 = Disabled 1 = Enabled
	6	LINEOUT2_FB	0	Enable ground loop noise feedback on LINEOUT2 0 = Disabled 1 = Enabled
	0	VROI	0	Buffered VMID to Analogue Line Output Resistance (Disabled Outputs) 0 = 20kohm from buffered VMID to output 1 = 500ohm from buffered VMID to output

Register 37h Additional Control

REGISTER ADDRESS	BIT	LABEL	DEFAULT	DESCRIPTION
R56 (38h) AntiPOP (1)	7	LINEOUT_VMID_BUF_ENA	0	Enables VMID reference for line outputs in single-ended mode 0 = Disabled 1 = Enabled
	6	HPOUT2_IN_EN A	0	HPOUT2MIX Mixer and Input Stage Enable 0 = Disabled 1 = Enabled
	5	LINEOUT1_DISC H	0	Discharges LINEOUT1P and LINEOUT1N outputs 0 = Not active 1 = Actively discharging LINEOUT1P and LINEOUT1N
	4	LINEOUT2_DISC H	0	Discharges LINEOUT2P and LINEOUT2N outputs 0 = Not active 1 = Actively discharging LINEOUT2P and LINEOUT2N

Register 38h AntiPOP (1)

REGISTER ADDRESS	BIT	LABEL	DEFAULT	DESCRIPTION
R57 (39h) AntiPOP (2)	8:7	JACKDET_MODE [1:0]	00	JACKDET mode select 00 = Jack Detect disabled 01 = Jack Detect enabled 10 = Jack Detect enabled 11 = Jack Detect enabled  MICDET (microphone/accessory detection) is not supported when JACKDET_MODE = 10. Analogue/Digital audio functions are not supported when JACKDET_MODE = 01 or 10.  LDO1_DISCH must be set to 0 when JACKDET_MODE = 01.  Settings 01 and 10 must not be selected if AVDD1 or DCVDD is supplied externally (ie. if LDO1 or LDO2 is not used).
	6:5	VMID_RAMP [1:0]	00	VMID soft start enable / slew rate control 00 = Normal slow start 01 = Normal fast start 10 = Soft slow start 11 = Soft fast start  If VMID_RAMP = 1X is selected for VMID start-up or shut-down, then the soft-start circuit must be reset by setting VMID_RAMP=00 after VMID is disabled, before VMID is re-enabled. VMID is disabled / enabled using the VMID_SEL register.
	3	VMID_BUF_ENA	0	VMID Buffer Enable 0 = Disabled 1 = Enabled (provided VMID_SEL > 00)
	2	STARTUP_BIAS_ENA	0	Enables the Start-Up bias current generator 0 = Disabled 1 = Enabled
	1	BIAS_SRC	0	Selects the bias current source 0 = Normal bias 1 = Start-Up bias
	0	VMID_DISCH	0	Connects VMID to ground 0 = Disabled 1 = Enabled

Register 39h AntiPOP (2)

REGISTER ADDRESS	BIT	LABEL	DEFAULT	DESCRIPTION
R59 (3Bh) LDO 1	3:1	LDO1_VSEL [2:0]	110	LDO1 Output Voltage Select 2.4V to 3.1V in 100mV steps 000 = 2.4V 001 = 2.5V 010 = 2.6V 011 = 2.7V 100 = 2.8V 101 = 2.9V 110 = 3.0V 111 = 3.1V

REGISTER ADDRESS	BIT	LABEL	DEFAULT	DESCRIPTION
	0	LDO1_DISCH	1	LDO1 Discharge Select 0 = LDO1 floating when disabled 1 = LDO1 discharged when disabled

Register 3Bh LDO 1

REGISTER ADDRESS	BIT	LABEL	DEFAULT	DESCRIPTION
R60 (3Ch) LDO 2	2:1	LDO2_VSEL [1:0]	01	LDO2 Output Voltage Select 1.05V to 1.25V in 100mV steps 00 = Reserved 01 = 1.05V 10 = 1.15V 11 = 1.25V
	0	LDO2_DISCH	1	LDO2 Discharge Select 0 = LDO2 floating when disabled 1 = LDO2 discharged when disabled

Register 3Ch LDO 2

REGISTER ADDRESS	BIT	LABEL	DEFAULT	DESCRIPTION
R61 (3Dh) MICBIAS1	5	MICB1_RATE	1	Microphone Bias 1 Rate 0 = Fast start-up / shut-down 1 = Pop-free start-up / shut-down
	4	MICB1_MODE	1	Microphone Bias 1 Mode 0 = Regulator mode 1 = Bypass mode
	3:1	MICB1_LVL [2:0]	100	Microphone Bias 1 Voltage Control (when MICB1_MODE = 0) 000 = 1.5V 001 = 1.8V 010 = 1.9V 011 = 2.0V 100 = 2.2V 101 = 2.4V 110 = 2.5V 111 = 2.6V
	0	MICB1_DISCH	1	Microphone Bias 1 Discharge 0 = MICBIAS1 floating when disabled 1 = MICBIAS1 discharged when disabled

Register 3Dh MICBIAS1

REGISTER ADDRESS	BIT	LABEL	DEFAULT	DESCRIPTION
R62 (3Eh) MICBIAS2	5	MICB2_RATE	1	Microphone Bias 2 Rate 0 = Fast start-up / shut-down 1 = Pop-free start-up / shut-down
	4	MICB2_MODE	1	Microphone Bias 2 Mode 0 = Regulator mode 1 = Bypass mode

REGISTER ADDRESS	BIT	LABEL	DEFAULT	DESCRIPTION
	3:1	MICB2_LVL [2:0]	100	Microphone Bias 2 Voltage Control (when MICB2_MODE = 0) 000 = 1.5V 001 = 1.8V 010 = 1.9V 011 = 2.0V 100 = 2.2V 101 = 2.4V 110 = 2.5V 111 = 2.6V
	0	MICB2_DISCH	1	Microphone Bias 2 Discharge 0 = MICBIAS2 floating when disabled 1 = MICBIAS2 discharged when disabled

Register 3Eh MICBIAS2

REGISTER ADDRESS	BIT	LABEL	DEFAULT	DESCRIPTION
R76 (4Ch) Charge Pump (1)	15	CP_ENA	0	Enable charge-pump digits 0 = Disable 1 = Enable

Register 4Ch Charge Pump (1)

REGISTER ADDRESS	BIT	LABEL	DEFAULT	DESCRIPTION
R77 (4Dh) Charge Pump (2)	15	CP_DISCH	1	Charge Pump Discharge Select 0 = Charge Pump outputs floating when disabled 1 = Charge Pump outputs discharged when disabled

Register 4Dh Charge Pump (2)

REGISTER ADDRESS	BIT	LABEL	DEFAULT	DESCRIPTION
R81 (51h) Class W (1)	9:8	CP_DYN_SRC_SEL [1:0]	00	Selects the digital audio source for envelope tracking 00 = AIF1, DAC data 01 = Reserved 10 = AIF2, DAC data 11 = Reserved
	0	CP_DYN_PWR	0	Enable dynamic charge pump power control 0 = charge pump controlled by volume register settings (Class G) 1 = charge pump controlled by real-time audio level (Class W)

Register 51h Class W (1)

REGISTER ADDRESS	BIT	LABEL	DEFAULT	DESCRIPTION
R84 (54h) DC Servo (1)	5	DCS_TRIG_STA_RTUP_1	0	Writing 1 to this bit selects Start-Up DC Servo mode for HPOUT1R. In readback, a value of 1 indicates that the DC Servo Start-Up correction is in progress.
	4	DCS_TRIG_STA_RTUP_0	0	Writing 1 to this bit selects Start-Up DC Servo mode for HPOUT1L. In readback, a value of 1 indicates that the DC Servo Start-Up correction is in progress.
	3	DCS_TRIG_DAC_WR_1	0	Writing 1 to this bit selects DAC Write DC Servo mode for HPOUT1R. In readback, a value of 1 indicates that the DC Servo DAC Write correction is in progress.
	2	DCS_TRIG_DAC_WR_0	0	Writing 1 to this bit selects DAC Write DC Servo mode for HPOUT1L. In readback, a value of 1 indicates that the DC Servo DAC Write correction is in progress.
	1	DCS_ENA_CHAN_1	0	DC Servo enable for HPOUT1R 0 = Disabled 1 = Enabled
	0	DCS_ENA_CHAN_0	0	DC Servo enable for HPOUT1L 0 = Disabled 1 = Enabled

Register 54h DC Servo (1)

REGISTER ADDRESS	BIT	LABEL	DEFAULT	DESCRIPTION
R85 (55h) DC Servo (2)	3:0	DCS_TIMER_PE RIOD_01 [3:0]	1010	This register must be set to 0000 for correct operation of the DC Servo. 0000 = DC Servo enabled All other values are Reserved

Register 55h DC Servo (2)

REGISTER ADDRESS	BIT	LABEL	DEFAULT	DESCRIPTION
R88 (58h) DC Servo Readback	9:8	DCS_CAL_COMPLETE [1:0]	00	DC Servo Complete status 0 = DAC Write or Start-Up DC Servo mode not completed. 1 = DAC Write or Start-Up DC Servo mode complete. Bit [1] = HPOUT1R Bit [0] = HPOUT1L
	5:4	DCS_DAC_WR_COMPLETE [1:0]	00	DC Servo DAC Write status 0 = DAC Write DC Servo mode not completed. 1 = DAC Write DC Servo mode complete. Bit [1] = HPOUT1R Bit [0] = HPOUT1L
	1:0	DCS_STARTUP_COMPLETE [1:0]	00	DC Servo Start-Up status 0 = Start-Up DC Servo mode not completed. 1 = Start-Up DC Servo mode complete. Bit [1] = HPOUT1R Bit [0] = HPOUT1L

Register 58h DC Servo Readback

REGISTER ADDRESS	BIT	LABEL	DEFAULT	DESCRIPTION
R89 (59h) DC Servo (4)	15:8	DCS_DAC_WR_VAL_1 [7:0]	0000_0000	Writing to this field sets the DC Offset value for HPOUT1R in DAC Write DC Servo mode. Reading this field gives the current DC Offset value for HPOUT1R. Two's complement format. LSB is 0.25mV. Range is -32mV to +31.75mV
	7:0	DCS_DAC_WR_VAL_0 [7:0]	0000_0000	Writing to this field sets the DC Offset value for HPOUT1L in DAC Write DC Servo mode. Reading this field gives the current DC Offset value for HPOUT1L. Two's complement format. LSB is 0.25mV. Range is -32mV to +31.75mV

Register 59h DC Servo (4)

REGISTER ADDRESS	BIT	LABEL	DEFAULT	DESCRIPTION
R96 (60h) Analogue HP (1)	8	HPOUT1_ATTEN	0	HPOUT1L and HPOUT1R Attenuation 0 = 0dB 1 = -3dB Note that, when CP_DYN_PWR=0, then any update to HPOUT1_ATTEN is not fully implemented until a '1' is written to HPOUT1_VU.
	7	HPOUT1L_RMV_SHORT	0	Removes HPOUT1L short 0 = HPOUT1L short enabled 1 = HPOUT1L short removed For normal operation, this bit should be set as the final step of the HPOUT1L Enable sequence.
	6	HPOUT1L_OUTP	0	Enables HPOUT1L output stage 0 = Disabled 1 = Enabled For normal operation, this bit should be set to 1 after the DC offset cancellation has been scheduled.
	5	HPOUT1L_DLY	0	Enables HPOUT1L intermediate stage 0 = Disabled 1 = Enabled For normal operation, this bit should be set to 1 after the output signal path has been configured, and before DC offset cancellation is scheduled. This bit should be set with at least 20us delay after HPOUT1L_ENA.
	3	HPOUT1R_RMV_SHORT	0	Removes HPOUT1R short 0 = HPOUT1R short enabled 1 = HPOUT1R short removed For normal operation, this bit should be set as the final step of the HPOUT1R Enable sequence.
	2	HPOUT1R_OUTP	0	Enables HPOUT1R output stage 0 = Disabled 1 = Enabled For normal operation, this bit should be set to 1 after the DC offset cancellation has been scheduled.
	1	HPOUT1R_DLY	0	Enables HPOUT1R intermediate stage 0 = Disabled 1 = Enabled For normal operation, this bit should be set to 1 after the output signal path has been configured, and before DC offset cancellation is scheduled. This bit should be set with at least 20us delay after HPOUT1R_ENA.

**Register 60h** Analogue HP (1)

REGISTER ADDRESS	BIT	LABEL	DEFAULT	DESCRIPTION
R197 (C5h) Class D Test (5)	0	SPKOUT_CLK_SRC	0	Selects the source for the CLASSD speaker clock 0: selects undithered clock 1: selects dithered clock

**Register C5h** Class D Test (5)

REGISTER ADDRESS	BIT	LABEL	DEFAULT	DESCRIPTION
R208 (D0h) Mic Detect 1	15:12	MICD_BIAS_STA RTTIME [3:0]	0111	Mic Detect Bias Startup Delay (If MICBIAS2 is not enabled already, this field selects the delay time allowed for MICBIAS2 to startup prior to performing the MICDET function.) 0000 = 0ms (continuous) 0001 = 0.25ms 0010 = 0.5ms 0011 = 1ms 0100 = 2ms 0101 = 4ms 0110 = 8ms 0111 = 16ms 1000 = 32ms 1001 = 64ms 1010 = 128ms 1011 = 256ms 1100 to 1111 = 512ms
	11:8	MICD_RATE [3:0]	0110	Mic Detect Rate (Selects the delay between successive Mic Detect measurements.) 0000 = 0ms (continuous) 0001 = 0.25ms 0010 = 0.5ms 0011 = 1ms 0100 = 2ms 0101 = 4ms 0110 = 8ms 0111 = 16ms 1000 = 32ms 1001 = 64ms 1010 = 128ms 1011 = 256ms 1100 to 1111 = 512ms
	1	MICD_DBTIME	0	Mic Detect De-bounce 0 = 2 measurements 1 = 4 measurements
	0	MICD_ENA	0	Mic Detect Enable 0 = Disabled 1 = Enabled Note that Mic Detect is not supported when JACKDET_MODE = 10.

Register D0h Mic Detect 1



REGISTER ADDRESS	BIT	LABEL	DEFAULT	DESCRIPTION
R209 (D1h) Mic Detect 2	7:0	MICD_LVL_SEL [7:0]	0111_1111	Mic Detect Level Select (enables Mic Detection in specific impedance ranges) [7] = Not used - must be set to 0 [6] = Enable >475 ohm detection [5] = Enable 326 ohm detection [4] = Enable 152 ohm detection [3] = Enable 77 ohm detection [2] = Enable 47.6 ohm detection [1] = Enable 29.4 ohm detection [0] = Enable 14 ohm detection Note that the impedance values quoted assume that a microphone (475ohm-30kohm) is also present on the MICDET pin.

Register D1h Mic Detect 2

REGISTER ADDRESS	BIT	LABEL	DEFAULT	DESCRIPTION
R210 (D2h) Mic Detect 3	10:2	MICD_LVL [8:0]	0_0000_0000	Mic Detect Level (indicates the measured impedance) [8] = Not used [7] = >475 ohm, <30k ohm [6] = 326 ohm [5] = 152 ohm [4] = 77 ohm [3] = 47.6 ohm [2] = 29.4 ohm [1] = 14 ohm [0] = <3 ohm Note that the impedance values quoted assume that a microphone (475ohm-30kohm) is also present on the MICDET pin.
	1	MICD_VALID	0	Mic Detect Data Valid 0 = Not Valid 1 = Valid
	0	MICD_STS	0	Mic Detect Status 0 = No Mic Accessory present(impedance is >30k ohm) 1 = Mic Accessory is present(impedance is <30k ohm)

Register D2h Mic Detect 3

REGISTER ADDRESS	BIT	LABEL	DEFAULT	DESCRIPTION
R256 (0100h) Chip Revision	15:8	CUST_ID [7:0]		Customer ID
	3:0	CHIP_REV [3:0]		Chip revision

Register 0100h Chip Revision

REGISTER ADDRESS	BIT	LABEL	DEFAULT	DESCRIPTION
R257 (0101h) Control Interface	15	Reserved	1	Reserved - do not change
	2	AUTO_INC	1	Enables address auto-increment 0 = Disabled 1 = Enabled

Register 0101h Control Interface

REGISTER ADDRESS	BIT	LABEL	DEFAULT	DESCRIPTION
R512 (0200h) AIF1 Clocking (1)	4:3	AIF1CLK_SRC [1:0]	00	AIF1CLK Source Select 00 = MCLK1 01 = MCLK2 10 = FLL1 11 = FLL2
	2	AIF1CLK_INV	0	AIF1CLK Invert 0 = AIF1CLK not inverted 1 = AIF1CLK inverted
	1	AIF1CLK_DIV	0	AIF1CLK Divider 0 = AIF1CLK 1 = AIF1CLK / 2
	0	AIF1CLK_ENA	0	AIF1CLK Enable 0 = Disabled 1 = Enabled

Register 0200h AIF1 Clocking (1)

REGISTER ADDRESS	BIT	LABEL	DEFAULT	DESCRIPTION
R513 (0201h) AIF1 Clocking (2)	5:3	AIF1DAC_DIV [2:0]	000	Selects the AIF1 input path sample rate relative to the AIF1 output path sample rate. This field should only be changed from default in modes where the AIF1 input path sample rate is slower than the AIF1 output path sample rate. 000 = Divide by 1 001 = Divide by 1.5 010 = Divide by 2 011 = Divide by 3 100 = Divide by 4 101 = Divide by 5.5 110 = Divide by 6 111 = Reserved
	2:0	AIF1ADC_DIV [2:0]	000	Selects the AIF1 output path sample rate relative to the AIF1 input path sample rate. This field should only be changed from default in modes where the AIF1 output path sample rate is slower than the AIF1 input path sample rate. 000 = Divide by 1 001 = Divide by 1.5 010 = Divide by 2 011 = Divide by 3 100 = Divide by 4 101 = Divide by 5.5 110 = Divide by 6 111 = Reserved

Register 0201h AIF1 Clocking (2)

REGISTER ADDRESS	BIT	LABEL	DEFAULT	DESCRIPTION
R516 (0204h) AIF2 Clocking (1)	4:3	AIF2CLK_SRC [1:0]	00	AIF2CLK Source Select 00 = MCLK1 01 = MCLK2 10 = FLL1 11 = FLL2
	2	AIF2CLK_INV	0	AIF2CLK Invert 0 = AIF2CLK not inverted 1 = AIF2CLK inverted
	1	AIF2CLK_DIV	0	AIF2CLK Divider 0 = AIF2CLK 1 = AIF2CLK / 2
	0	AIF2CLK_ENA	0	AIF2CLK Enable 0 = Disabled 1 = Enabled

Register 0204h AIF2 Clocking (1)

REGISTER ADDRESS	BIT	LABEL	DEFAULT	DESCRIPTION
R520 (0208h) Clocking (1)	4	TOCLK_ENA	0	Slow Clock (TOCLK) Enable 0 = Disabled 1 = Enabled This clock is required for zero-cross timeout.
	3	AIF1DSPCLK_EN A	0	AIF1 Processing Clock Enable 0 = Disabled 1 = Enabled
	2	AIF2DSPCLK_EN A	0	AIF2 Processing Clock Enable 0 = Disabled 1 = Enabled
	1	SYSDSPCLK_EN A	0	Digital Mixing Processor Clock Enable 0 = Disabled 1 = Enabled
	0	SYSCLK_SRC	0	SYSCLK Source Select 0 = AIF1CLK 1 = AIF2CLK

Register 0208h Clocking (1)

REGISTER ADDRESS	BIT	LABEL	DEFAULT	DESCRIPTION
R521 (0209h) Clocking (2)	10:8	TOCLK_DIV [2:0]	000	Slow Clock (TOCLK) Divider (Sets TOCLK rate relative to 256kHz.) 000 = Divide by 256 (1kHz) 001 = Divide by 512 (500Hz) 010 = Divide by 1024 (250Hz) 011 = Divide by 2048 (125Hz) 100 = Divide by 4096 (62.5Hz) 101 = Divide by 8192 (31.2Hz) 110 = Divide by 16384 (15.6Hz) 111 = Divide by 32768 (7.8Hz)
	6:4	DBCLK_DIV [2:0]	000	De-bounce Clock (DBCLK) Divider (Sets DBCLK rate relative to 256kHz.)

REGISTER ADDRESS	BIT	LABEL	DEFAULT	DESCRIPTION
				000 = Divide by 256 (1kHz) 001 = Divide by 2048 (125Hz) 010 = Divide by 4096 (62.5Hz) 011 = Divide by 8192 (31.2Hz) 100 = Divide by 16384 (15.6Hz) 101 = Divide by 32768 (7.8Hz) 110 = Divide by 65536 (3.9Hz) 111 = Divide by 131072 (1.95Hz)
	2:0	OPCLK_DIV [2:0]	000	GPIO Output Clock (OPCLK) Divider 000 = SYSCLK 001 = SYSCLK / 2 010 = SYSCLK / 3 011 = SYSCLK / 4 100 = SYSCLK / 6 101 = SYSCLK / 8 110 = SYSCLK / 12 111 = SYSCLK / 16

Register 0209h Clocking (2)

REGISTER ADDRESS	BIT	LABEL	DEFAULT	DESCRIPTION
R528 (0210h) AIF1 Rate	7:4	AIF1_SR [3:0]	1000	Selects the AIF1 Sample Rate (fs) 0000 = 8kHz 0001 = 11.025kHz 0010 = 12kHz 0011 = 16kHz 0100 = 22.05kHz 0101 = 24kHz 0110 = 32kHz 0111 = 44.1kHz 1000 = 48kHz 1001 = 88.2kHz 1010 = 96kHz All other codes = Reserved Note that 88.2kHz and 96kHz modes are supported for AIF1 input (DAC playback) only.
	3:0	AIF1CLK_RATE [3:0]	0011	Selects the AIF1CLK / fs ratio 0000 = Reserved 0001 = 128 0010 = 192 0011 = 256 0100 = 384 0101 = 512 0110 = 768 0111 = 1024 1000 = 1408 1001 = 1536 All other codes = Reserved

Register 0210h AIF1 Rate

REGISTER ADDRESS	BIT	LABEL	DEFAULT	DESCRIPTION
R529 (0211h) AIF2 Rate	7:4	AIF2_SR [3:0]	1000	Selects the AIF2 Sample Rate (fs) 0000 = 8kHz 0001 = 11.025kHz 0010 = 12kHz 0011 = 16kHz 0100 = 22.05kHz 0101 = 24kHz 0110 = 32kHz 0111 = 44.1kHz 1000 = 48kHz 1001 = 88.2kHz 1010 = 96kHz All other codes = Reserved Note that 88.2kHz and 96kHz modes are supported for AIF2 input (DAC playback) only.
	3:0	AIF2CLK_RATE [3:0]	0011	Selects the AIF2CLK / fs ratio 0000 = Reserved 0001 = 128 0010 = 192 0011 = 256 0100 = 384 0101 = 512 0110 = 768 0111 = 1024 1000 = 1408 1001 = 1536 All other codes = Reserved

Register 0211h AIF2 Rate

REGISTER ADDRESS	BIT	LABEL	DEFAULT	DESCRIPTION
R530 (0212h) Rate Status	3:0	SR_ERROR [3:0]	0000	Sample Rate Configuration status Indicates an error with the register settings related to sample rate configuration 0000 = No errors 0001 = Invalid sample rate 0010 = Invalid AIF divide 0011 = ADC and DAC divides both set in an interface 0100 = Invalid combination of AIF divides and sample-rate 0101 = Invalid set of enables for 96kHz mode 0110 = Invalid SYSCLK rate (derived from AIF1CLK_RATE or AIF2CLK_RATE) 0111 = Mixed ADC and DAC rates in SYSCLK AIF when AIFs are asynchronous 1000 = Invalid combination of sample rates when both AIFs are from the same clock source 1001 = Invalid combination of mixed ADC/DAC AIFs when both from the same clock source

Register 0212h Rate Status

REGISTER ADDRESS	BIT	LABEL	DEFAULT	DESCRIPTION
R544 (0220h) FLL1 Control (1)	1	FLL1_OSC_ENA	0	FLL1 Oscillator enable 0 = Disabled 1 = Enabled (Note that this field is required for free-running FLL1 modes only)
	0	FLL1_ENA	0	FLL1 Enable 0 = Disabled 1 = Enabled This should be set as the final step of the FLL1 enable sequence, ie. after the other FLL registers have been configured.

Register 0220h FLL1 Control (1)

REGISTER ADDRESS	BIT	LABEL	DEFAULT	DESCRIPTION
R545 (0221h) FLL1 Control (2)	13:8	FLL1_OUTDIV [5:0]	00_0000	FLL1 FOUT clock divider 000000 = Reserved 000001 = Reserved 000010 = Reserved 000011 = 4 000100 = 5 000101 = 6 ... 111110 = 63 111111 = 64 (FOUT = FVCO / FLL1_OUTDIV)
	2:0	FLL1_FRATIO [2:0]	000	FLL1 FVCO clock divider 000 = 1 001 = 2 010 = 4 011 = 8 1XX = 16

Register 0221h FLL1 Control (2)

REGISTER ADDRESS	BIT	LABEL	DEFAULT	DESCRIPTION
R546 (0222h) FLL1 Control (3)	15:0	FLL1_THETA [15:0]	0000_0000_00 00_0000	FLL Fractional multiply for FREF This field sets the numerator (multiply) part of the FLL1_THETA / FLL1_LAMBDA ratio. Coded as LSB = 1.

Register 0222h FLL1 Control (3)

REGISTER ADDRESS	BIT	LABEL	DEFAULT	DESCRIPTION
R547 (0223h) FLL1 Control (4)	14:5	FLL1_N [9:0]	00_0000_0000	FLL Integer multiply for FREF (LSB = 1)

Register 0223h FLL1 Control (4)

REGISTER ADDRESS	BIT	LABEL	DEFAULT	DESCRIPTION
R548 (0224h) FLL1 Control (5)	15	FLL1_BYP	0	FLL1 Bypass Select 0 = Disabled 1 = Enabled When FLL1_BYP is set, the FLL1 output is derived directly from BCLK1. In this case, FLL1 can be disabled.
	12:7	FLL1_FRC_NCO_VAL [5:0]	01_1001	FLL1 Forced oscillator value Valid range is 000000 to 111111 0x19h (011001) = 12MHz approx (Note that this field is required for free-running FLL modes only)
	6	FLL1_FRC_NCO	0	FLL1 Forced control select 0 = Normal 1 = FLL1 oscillator controlled by FLL1_FRC_NCO_VAL (Note that this field is required for free-running FLL modes only)
	4:3	FLL1_REFCLK_DIV [1:0]	00	FLL1 Clock Reference Divider 00 = MCLK / 1 01 = MCLK / 2 10 = MCLK / 4 11 = MCLK / 8  MCLK (or other input reference) must be divided down to <=13.5MHz. For lower power operation, the reference clock can be divided down further if desired.
	1:0	FLL1_REFCLK_SRC [1:0]	00	FLL1 Clock source 00 = MCLK1 01 = MCLK2 10 = LRCLK1 11 = BCLK1

Register 0224h FLL1 Control (5)

REGISTER ADDRESS	BIT	LABEL	DEFAULT	DESCRIPTION
R550 (0226h) FLL1 EFS 1	15:0	FLL1_LAMBDA [15:0]	0000_0000_00_0000	FLL Fractional multiply for FREF This field sets the denominator (dividing) part of the FLL1_THETA / FLL1_LAMBDA ratio. Coded as LSB = 1.

Register 0226h FLL1 EFS 1

REGISTER ADDRESS	BIT	LABEL	DEFAULT	DESCRIPTION
R551 (0227h) FLL1 EFS 2	2	Reserved	1	Reserved - do not change
	1	Reserved	1	Reserved - do not change
	0	FLL1_EFS_ENA	0	FLL Fractional Mode EFS enable 0 = Integer Mode 1 = Fractional Mode This bit should be set to 1 when FLL1_THETA > 0.

Register 0227h FLL1 EFS 2

REGISTER ADDRESS	BIT	LABEL	DEFAULT	DESCRIPTION
R576 (0240h) FLL2Control (1)	1	FLL2_OSC_ENA	0	FLL2 Oscillator enable 0 = Disabled 1 = Enabled (Note that this field is required for free-running FLL2 modes only)
	0	FLL2_ENA	0	FLL2 Enable 0 = Disabled 1 = Enabled This should be set as the final step of the FLL2 enable sequence, ie. after the other FLL registers have been configured.

Register 0240h FLL2Control (1)

REGISTER ADDRESS	BIT	LABEL	DEFAULT	DESCRIPTION
R577 (0241h) FLL2Control (2)	13:8	FLL2_OUTDIV [5:0]	00_0000	FLL2 FOUT clock divider 000000 = Reserved 000001 = Reserved 000010 = Reserved 000011 = 4 000100 = 5 000101 = 6 ... 111110 = 63 111111 = 64 (FOUT = FVCO / FLL2_OUTDIV)
	2:0	FLL2_FRATIO [2:0]	000	FLL2 FVCO clock divider 000 = 1 001 = 2 010 = 4 011 = 8 1XX = 16

Register 0241h FLL2Control (2)

REGISTER ADDRESS	BIT	LABEL	DEFAULT	DESCRIPTION
R578 (0242h) FLL2Control (3)	15:0	FLL2_THETA [15:0]	0000_0000_00 00_0000	FLL Fractional multiply for FREF This field sets the numerator (multiply) part of the FLL2_THETA / FLL2_LAMBDA ratio. Coded as LSB = 1.

Register 0242h FLL2Control (3)

REGISTER ADDRESS	BIT	LABEL	DEFAULT	DESCRIPTION
R579 (0243h) FLL2 Control (4)	14:5	FLL2_N [9:0]	00_0000_0000	FLL Integer multiply for FREF (LSB = 1)

Register 0243h FLL2 Control (4)



REGISTER ADDRESS	BIT	LABEL	DEFAULT	DESCRIPTION
R580 (0244h) FLL2Control (5)	15	FLL2_BYP	0	FLL2 Bypass Select 0 = Disabled 1 = Enabled When FLL2_BYP is set, the FLL2 output is derived directly from BCLK2. In this case, FLL2 can be disabled.
	12:7	FLL2_FRC_NCO_VAL [5:0]	01_1001	FLL2 Forced oscillator value Valid range is 000000 to 111111 0x19h (011001) = 12MHz approx (Note that this field is required for free-running FLL modes only)
	6	FLL2_FRC_NCO	0	FLL2 Forced control select 0 = Normal 1 = FLL2 oscillator controlled by FLL2_FRC_NCO_VAL (Note that this field is required for free-running FLL modes only)
	4:3	FLL2_REFCLK_DIV [1:0]	00	FLL2 Clock Reference Divider 00 = MCLK / 1 01 = MCLK / 2 10 = MCLK / 4 11 = MCLK / 8  MCLK (or other input reference) must be divided down to <=13.5MHz. For lower power operation, the reference clock can be divided down further if desired.
	1:0	FLL2_REFCLK_SRC [1:0]	00	FLL2 Clock source 00 = MCLK1 01 = MCLK2 10 = LRCLK2 11 = BCLK2

Register 0244h FLL2Control (5)

REGISTER ADDRESS	BIT	LABEL	DEFAULT	DESCRIPTION
R582 (0246h) FLL2 EFS 1	15:0	FLL2_LAMBDA [15:0]	0000_0000_00 00_0000	FLL Fractional multiply for FREF This field sets the denominator (dividing) part of the FLL2_THETA / FLL2_LAMBDA ratio. Coded as LSB = 1.

Register 0246h FLL2 EFS 1

REGISTER ADDRESS	BIT	LABEL	DEFAULT	DESCRIPTION
R583 (0247h) FLL2 EFS 2	2	Reserved	1	Reserved - do not change
	1	Reserved	1	Reserved - do not change
	0	FLL2_EFS_ENA	0	FLL Fractional Mode EFS enable 0 = Integer Mode 1 = Fractional Mode This bit should be set to 1 when FLL2_THETA > 0.

Register 0247h FLL2 EFS 2

REGISTER ADDRESS	BIT	LABEL	DEFAULT	DESCRIPTION
R768 (0300h) AIF1 Control (1)	15	AIF1ADCL_SRC	0	AIF1 Left Digital Audio interface source 0 = Left ADC data is output on left channel 1 = Right ADC data is output on left channel
	14	AIF1ADCR_SRC	1	AIF1 Right Digital Audio interface source 0 = Left ADC data is output on right channel 1 = Right ADC data is output on right channel
	13	AIF1ADC_TDM	0	AIF1 transmit (ADC) TDM Enable 0 = Normal ADCDAT1 operation 1 = TDM enabled on ADCDAT1
	12	AIF1ADC_TDM_CHAN	0	AIF1 transmit (ADC) TDM Slot Select 0 = Slot 0 1 = Slot 1
	8	AIF1_BCLK_INV	0	BCLK1 Invert 0 = BCLK1 not inverted 1 = BCLK1 inverted Note that AIF1_BCLK_INV selects the BCLK1 polarity in Master mode and in Slave mode.
	6:5	AIF1_WL [1:0]	10	AIF1 Digital Audio Interface Word Length 00 = 16 bits 01 = 20 bits 10 = 24 bits 11 = 32 bits Note - 8-bit modes can be selected using the "Companding" control bits.
	4:3	AIF1_FMT [1:0]	10	AIF1 Digital Audio Interface Format 00 = Right justified 01 = Left justified 10 = I2S Format 11 = DSP Mode

Register 0300h AIF1 Control (1)

REGISTER ADDRESS	BIT	LABEL	DEFAULT	DESCRIPTION
R769 (0301h) AIF1 Control (2)	15	AIF1DACL_SRC	0	AIF1 Left Receive Data Source Select 0 = Left DAC receives left interface data 1 = Left DAC receives right interface data
	14	AIF1DACR_SRC	1	AIF1 Right Receive Data Source Select 0 = Right DAC receives left interface data 1 = Right DAC receives right interface data
	13	AIF1DAC_TDM	0	AIF1 receive (DAC) TDM Enable 0 = Normal DACDAT1 operation 1 = TDM enabled on DACDAT1
	12	AIF1DAC_TDM_CHAN	0	AIF1 receive (DAC) TDM Slot Select 0 = Slot 0 1 = Slot 1
	11:10	AIF1DAC_BOOST [1:0]	00	AIF1 Input Path Boost 00 = 0dB 01 = +6dB (input must not exceed -6dBFS) 10 = +12dB (input must not exceed -12dBFS) 11 = +18dB (input must not exceed -18dBFS)
	8	AIF1_MONO	0	AIF1 DSP Mono Mode 0 = Disabled

REGISTER ADDRESS	BIT	LABEL	DEFAULT	DESCRIPTION
				1 = Enabled Note that Mono Mode is only supported when AIF1_FMT = 11.
	4	AIF1DAC_COMP	0	AIF1 Receive Companding Enable 0 = Disabled 1 = Enabled
	3	AIF1DAC_COMP MODE	0	AIF1 Receive Companding Type 0 = $\mu$ -law 1 = A-law
	2	AIF1ADC_COMP	0	AIF1 Transmit Companding Enable 0 = Disabled 1 = Enabled
	1	AIF1ADC_COMP MODE	0	AIF1 Transmit Companding Type 0 = $\mu$ -law 1 = A-law
	0	AIF1_LOOPBACK	0	AIF1 Digital Loopback Function 0 = No loopback 1 = Loopback enabled (ADCDAT1 data output is directly input to DACDAT1 data input).

Register 0301h AIF1 Control (2)

REGISTER ADDRESS	BIT	LABEL	DEFAULT	DESCRIPTION
R770 (0302h) AIF1 Master/ Slave	15	AIF1_TRI	0	AIF1 Audio Interface tri-state 0 = AIF1 pins operate normally 1 = Tri-state all AIF1 interface pins Note that the GPIO1 pin is controlled by this register only when configured as ADCLRCLK1.
	14	AIF1_MSTR	0	AIF1 Audio Interface Master Mode Select 0 = Slave mode 1 = Master mode
	13	AIF1_CLK_FRC	0	Forces BCLK1, LRCLK1 and ADCLRCLK1 to be enabled when all AIF1 audio channels are disabled. 0 = Normal 1 = BCLK1, LRCLK1 and ADCLRCLK1 always enabled in Master mode
	12	AIF1_LRCLK_FR C	0	Forces LRCLK1 and ADCLRCLK1 to be enabled when all AIF1 audio channels are disabled. 0 = Normal 1 = LRCLK1 and ADCLRCLK1 always enabled in Master mode

Register 0302h AIF1 Master/Slave

REGISTER ADDRESS	BIT	LABEL	DEFAULT	DESCRIPTION
R771 (0303h) AIF1 BCLK	8:4	AIF1_BCLK_DIV [4:0]	0_0100	BCLK1 Rate 00000 = AIF1CLK 00001 = AIF1CLK / 1.5 00010 = AIF1CLK / 2 00011 = AIF1CLK / 3 00100 = AIF1CLK / 4 00101 = AIF1CLK / 5 00110 = AIF1CLK / 6

REGISTER ADDRESS	BIT	LABEL	DEFAULT	DESCRIPTION
				00111 = AIF1CLK / 8 01000 = AIF1CLK / 11 01001 = AIF1CLK / 12 01010 = AIF1CLK / 16 01011 = AIF1CLK / 22 01100 = AIF1CLK / 24 01101 = AIF1CLK / 32 01110 = AIF1CLK / 44 01111 = AIF1CLK / 48 10000 = AIF1CLK / 64 10001 = AIF1CLK / 88 10010 = AIF1CLK / 96 10011 = AIF1CLK / 128 10100 = AIF1CLK / 176 10101 = AIF1CLK / 192 10110 - 11111 = Reserved

Register 0303h AIF1 BCLK

REGISTER ADDRESS	BIT	LABEL	DEFAULT	DESCRIPTION
R772 (0304h) AIF1ADC LRCLK	12	AIF1ADC_LRCLK_INV	0	Right, left and I2S modes – ADCLRCLK1 polarity 0 = normal ADCLRCLK1 polarity 1 = invert ADCLRCLK1 polarity Note that AIF1ADC_LRCLK_INV selects the ADCLRCLK1 polarity in Master mode and in Slave mode.  DSP Mode – mode A/B select 0 = MSB is available on 2nd BCLK1 rising edge after ADCLRCLK1 rising edge (mode A) 1 = MSB is available on 1st BCLK1 rising edge after ADCLRCLK1 rising edge (mode B)
	11	AIF1ADC_LRCLK_DIR	0	Allows ADCLRCLK1 to be enabled in Slave mode 0 = Normal 1 = ADCLRCLK1 enabled in Slave mode
	10:0	AIF1ADC_RATE [10:0]	000_0100_000 0	ADCLRCLK1 Rate ADCLRCLK1 clock output = BCLK1 / AIF1ADC_RATE  Integer (LSB = 1) Valid from 8..2047

Register 0304h AIF1ADC LRCLK

REGISTER ADDRESS	BIT	LABEL	DEFAULT	DESCRIPTION
R773 (0305h) AIF1DAC LRCLK	12	AIF1DAC_LRCLK_INV	0	Right, left and I2S modes – LRCLK1 polarity 0 = normal LRCLK1 polarity 1 = invert LRCLK1 polarity Note that AIF1DAC_LRCLK_INV selects the LRCLK1 polarity in Master mode and in Slave mode.  DSP Mode – mode A/B select 0 = MSB is available on 2nd BCLK1 rising edge after LRCLK1 rising edge (mode A) 1 = MSB is available on 1st BCLK1 rising edge after LRCLK1 rising edge (mode B)
	11	AIF1DAC_LRCLK_DIR	0	Allows LRCLK1 to be enabled in Slave mode 0 = Normal 1 = LRCLK1 enabled in Slave mode
	10:0	AIF1DAC_RATE [10:0]	000_0100_000 0	LRCLK1 Rate LRCLK1 clock output = BCLK1 / AIF1DAC_RATE  Integer (LSB = 1) Valid from 8..2047

Register 0305h AIF1DAC LRCLK

REGISTER ADDRESS	BIT	LABEL	DEFAULT	DESCRIPTION
R774 (0306h) AIF1DAC Data	1	AIF1DACL_DAT_INV	0	AIF1 Left Receive Data Invert 0 = Not inverted 1 = Inverted
	0	AIF1DACR_DAT_INV	0	AIF1 Right Receive Data Invert 0 = Not inverted 1 = Inverted

Register 0306h AIF1DAC Data

REGISTER ADDRESS	BIT	LABEL	DEFAULT	DESCRIPTION
R775 (0307h) AIF1ADC Data	1	AIF1ADCL_DAT_INV	0	AIF1 Left Transmit Data Invert 0 = Not inverted 1 = Inverted
	0	AIF1ADCR_DAT_INV	0	AIF1 Right Transmit Data Invert 0 = Not inverted 1 = Inverted

Register 0307h AIF1ADC Data

REGISTER ADDRESS	BIT	LABEL	DEFAULT	DESCRIPTION
R784 (0310h) AIF2 Control (1)	15	AIF2ADCL_SRC	0	AIF2 Left Digital Audio interface source 0 = Left ADC data is output on left channel 1 = Right ADC data is output on left channel
	14	AIF2ADCR_SRC	1	AIF2 Right Digital Audio interface source 0 = Left ADC data is output on right channel 1 = Right ADC data is output on right channel
	13	AIF2ADC_TDM	0	AIF2 transmit (ADC) TDM Enable 0 = Normal ADCDAT2 operation 1 = TDM enabled on ADCDAT2
	12	AIF2ADC_TDM_CHAN	0	AIF2 transmit (ADC) TDM Slot Select 0 = Slot 0 1 = Slot 1
	8	AIF2_BCLK_INV	0	BCLK2 Invert 0 = BCLK2 not inverted 1 = BCLK2 inverted Note that AIF2_BCLK_INV selects the BCLK2 polarity in Master mode and in Slave mode.
	6:5	AIF2_WL [1:0]	10	AIF2 Digital Audio Interface Word Length 00 = 16 bits 01 = 20 bits 10 = 24 bits 11 = 32 bits Note - 8-bit modes can be selected using the "Companding" control bits.
	4:3	AIF2_FMT [1:0]	10	AIF2 Digital Audio Interface Format 00 = Right justified 01 = Left justified 10 = I2S Format 11 = DSP Mode

Register 0310h AIF2 Control (1)

REGISTER ADDRESS	BIT	LABEL	DEFAULT	DESCRIPTION
R785 (0311h) AIF2 Control (2)	15	AIF2DACL_SRC	0	AIF2 Left Receive Data Source Select 0 = Left DAC receives left interface data 1 = Left DAC receives right interface data
	14	AIF2DACR_SRC	1	AIF2 Right Receive Data Source Select 0 = Right DAC receives left interface data 1 = Right DAC receives right interface data
	13	AIF2DAC_TDM	0	AIF2 receive (DAC) TDM Enable 0 = Normal DACDAT2 operation 1 = TDM enabled on DACDAT2
	12	AIF2DAC_TDM_CHAN	0	AIF2 receive (DAC) TDM Slot Select 0 = Slot 0 1 = Slot 1
	11:10	AIF2DAC_BOOST [1:0]	00	AIF2 Input Path Boost 00 = 0dB 01 = +6dB (input must not exceed -6dBFS) 10 = +12dB (input must not exceed -12dBFS) 11 = +18dB (input must not exceed -18dBFS)

REGISTER ADDRESS	BIT	LABEL	DEFAULT	DESCRIPTION
	8	AIF2_MONO	0	AIF2 DSP Mono Mode 0 = Disabled 1 = Enabled Note that Mono Mode is only supported when AIF2_FMT = 11.
	4	AIF2DAC_COMP	0	AIF2 Receive Companding Enable 0 = Disabled 1 = Enabled
	3	AIF2DAC_COMP MODE	0	AIF2 Receive Companding Type 0 = $\mu$ -law 1 = A-law
	2	AIF2ADC_COMP	0	AIF2 Transmit Companding Enable 0 = Disabled 1 = Enabled
	1	AIF2ADC_COMP MODE	0	AIF2 Transmit Companding Type 0 = $\mu$ -law 1 = A-law
	0	AIF2_LOOPBACK	0	AIF2 Digital Loopback Function 0 = No loopback 1 = Loopback enabled (ADCDAT2 data output is directly input to DACDAT2 data input).

Register 0311h AIF2 Control (2)

REGISTER ADDRESS	BIT	LABEL	DEFAULT	DESCRIPTION
R786 (0312h) AIF2 Master/ Slave	15	AIF2_TRI	0	AIF2 Audio Interface tri-state 0 = AIF2 pins operate normally 1 = Tri-state all AIF2 interface pins Note that pins not configured as AIF2 functions are not affected by this register.
	14	AIF2_MSTR	0	AIF2 Audio Interface Master Mode Select 0 = Slave mode 1 = Master mode
	13	AIF2_CLK_FRC	0	Forces BCLK2 and LRCLK2 to be enabled when all AIF2 audio channels are disabled. 0 = Normal 1 = BCLK2 and LRCLK2 always enabled in Master mode
	12	AIF2_LRCLK_FR C	0	Forces LRCLK2 to be enabled when all AIF2 audio channels are disabled. 0 = Normal 1 = LRCLK2 always enabled in Master mode

Register 0312h AIF2 Master/Slave

REGISTER ADDRESS	BIT	LABEL	DEFAULT	DESCRIPTION
R787 (0313h) AIF2 BCLK	8:4	AIF2_BCLK_DIV [4:0]	0_0100	BCLK2 Rate 00000 = AIF2CLK 00001 = AIF2CLK / 1.5 00010 = AIF2CLK / 2 00011 = AIF2CLK / 3 00100 = AIF2CLK / 4 00101 = AIF2CLK / 5 00110 = AIF2CLK / 6 00111 = AIF2CLK / 8 01000 = AIF2CLK / 11 01001 = AIF2CLK / 12 01010 = AIF2CLK / 16 01011 = AIF2CLK / 22 01100 = AIF2CLK / 24 01101 = AIF2CLK / 32 01110 = AIF2CLK / 44 01111 = AIF2CLK / 48 10000 = AIF2CLK / 64 10001 = AIF2CLK / 88 10010 = AIF2CLK / 96 10011 = AIF2CLK / 128 10100 = AIF2CLK / 176 10101 = AIF2CLK / 192 10110 - 11111 = Reserved

Register 0313h AIF2 BCLK

REGISTER ADDRESS	BIT	LABEL	DEFAULT	DESCRIPTION
R788 (0314h) AIF2ADC LRCLK	12	AIF2ADC_LRCLK _INV	0	DSP Mode – mode A/B select (AIF2 output) 0 = MSB is available on 2nd BCLK2 rising edge after LRCLK2 rising edge (mode A) 1 = MSB is available on 1st BCLK2 rising edge after LRCLK2 rising edge (mode B)
	6		1	Reserved - do not change

Register 0314h AIF2ADC LRCLK



REGISTER ADDRESS	BIT	LABEL	DEFAULT	DESCRIPTION
R789 (0315h) AIF2DAC LRCLK	12	AIF2DAC_LRCLK_INV	0	Right, left and I2S modes – LRCLK2 polarity 0 = normal LRCLK2 polarity 1 = invert LRCLK2 polarity Note that AIF2DAC_LRCLK_INV selects the LRCLK2 polarity in Master mode and in Slave mode.  DSP Mode – mode A/B select (AIF2 input) 0 = MSB is available on 2nd BCLK2 rising edge after LRCLK2 rising edge (mode A) 1 = MSB is available on 1st BCLK2 rising edge after LRCLK2 rising edge (mode B)
	11	AIF2DAC_LRCLK_DIR	0	Allows LRCLK2 to be enabled in Slave mode 0 = Normal 1 = LRCLK2 enabled in Slave mode
	10:0	AIF2DAC_RATE [10:0]	000_0100_000 0	LRCLK2 Rate LRCLK2 clock output = BCLK2 / AIF2DAC_RATE  Integer (LSB = 1) Valid from 8..2047

Register 0315h AIF2DAC LRCLK

REGISTER ADDRESS	BIT	LABEL	DEFAULT	DESCRIPTION
R790 (0316h) AIF2DAC Data	1	AIF2DACL_DAT_INV	0	AIF2 Left Receive Data Invert 0 = Not inverted 1 = Inverted
	0	AIF2DACR_DAT_INV	0	AIF2 Right Receive Data Invert 0 = Not inverted 1 = Inverted

Register 0316h AIF2DAC Data

REGISTER ADDRESS	BIT	LABEL	DEFAULT	DESCRIPTION
R791 (0317h) AIF2ADC Data	1	AIF2ADCL_DAT_INV	0	AIF2 Left Transmit Data Invert 0 = Not inverted 1 = Inverted
	0	AIF2ADCR_DAT_INV	0	AIF2 Right Transmit Data Invert 0 = Not inverted 1 = Inverted

Register 0317h AIF2ADC Data

REGISTER ADDRESS	BIT	LABEL	DEFAULT	DESCRIPTION
R792 (0318h) AIF2TX Control	1	AIF2TXL_ENA	1	Enable AIF2DAC (Left) input path 0 = Disabled 1 = Enabled  This bit must be set for AIF2 output of the AIF2ADC (Left) signal. For AIF3 output only, this bit can be set to 0.

REGISTER ADDRESS	BIT	LABEL	DEFAULT	DESCRIPTION
	0	AIF2TXR_ENA	1	Enable AIF2DAC (Right) input path 0 = Disabled 1 = Enabled This bit must be set for AIF2 output of the AIF2ADC (Left) signal. For AIF3 output only, this bit can be set to 0.

Register 0318h AIF2TX Control

REGISTER ADDRESS	BIT	LABEL	DEFAULT	DESCRIPTION
R800 (0320h) AIF3 Control (1)	7	AIF3_LRCLK_INV	0	Right, left and I2S modes – LRCLK3 polarity 0 = normal LRCLK3 polarity 1 = invert LRCLK3 polarity  DSP Mode – mode A/B select 0 = MSB is available on 2nd BCLK3 rising edge after LRCLK3 rising edge (mode A) 1 = MSB is available on 1st BCLK3 rising edge after LRCLK3 rising edge (mode B)
	6:5	AIF3_WL [1:0]	10	AIF3 Digital Audio Interface Word Length 00 = 16 bits 01 = 20 bits 10 = 24 bits 11 = 32 bits Note - 8-bit modes can be selected using the “Companding” control bits. Note that this controls the AIF3 Mono PCM interface path only; it does not affect AIF3 inputs/outputs routed to AIF1 or AIF2.

Register 0320h AIF3 Control (1)

REGISTER ADDRESS	BIT	LABEL	DEFAULT	DESCRIPTION
R801 (0321h) AIF3 Control (2)	11:10	AIF3DAC_BOOST [1:0]	00	AIF3 Input Path Boost 00 = 0dB 01 = +6dB (input must not exceed -6dBFS) 10 = +12dB (input must not exceed -12dBFS) 11 = +18dB (input must not exceed -18dBFS) Note that this controls the AIF3 Mono PCM interface path only; it does not affect DACDAT3 input to AIF1 or AIF2.
	4	AIF3DAC_COMP	0	AIF3 Receive Companding Enable 0 = Disabled 1 = Enabled Note that this controls the AIF3 Mono PCM interface path only; it does not affect DACDAT3 input to AIF1 or AIF2.
	3	AIF3DAC_COMP MODE	0	AIF3 Receive Companding Type 0 = $\mu$ -law 1 = A-law Note that this controls the AIF3 Mono PCM interface path only; it does not affect DACDAT3 input to AIF1 or AIF2.

REGISTER ADDRESS	BIT	LABEL	DEFAULT	DESCRIPTION
	2	AIF3ADC_COMP	0	AIF3 Transmit Companding Enable 0 = Disabled 1 = Enabled Note that this controls the AIF3 Mono PCM interface path only; it does not affect ADCDAT3 output from AIF1 or AIF2.
	1	AIF3ADC_COMP MODE	0	AIF3 Transmit Companding Type 0 = $\mu$ -law 1 = A-law Note that this controls the AIF3 Mono PCM interface path only; it does not affect ADCDAT3 output from AIF1 or AIF2.
	0	AIF3_LOOPBACK	0	AIF3 Digital Loopback Function 0 = No loopback 1 = Loopback enabled (AIF3 Mono PCM data output is directly input to AIF3 Mono PCM data input).

Register 0321h AIF3 Control (2)

REGISTER ADDRESS	BIT	LABEL	DEFAULT	DESCRIPTION
R802 (0322h) AIF3DAC Data	0	AIF3DAC_DAT_I NV	0	AIF3 Receive Data Invert 0 = Not inverted 1 = Inverted Note that this controls the AIF3 Mono PCM interface path only; it does not affect DACDAT3 input to AIF1 or AIF2.

Register 0322h AIF3DAC Data

REGISTER ADDRESS	BIT	LABEL	DEFAULT	DESCRIPTION
R803 (0323h) AIF3ADC Data	0	AIF3ADC_DAT_I NV	0	AIF3 Transmit Data Invert 0 = Not inverted 1 = Inverted Note that this controls the AIF3 Mono PCM interface path only; it does not affect ADCDAT3 output from AIF1 or AIF2.

Register 0323h AIF3ADC Data

REGISTER ADDRESS	BIT	LABEL	DEFAULT	DESCRIPTION
R1024 (0400h) AIF1 ADC1 Left Volume	8	AIF1ADC1_VU	0	AIF1ADC output path Volume Update Writing a 1 to this bit will cause the AIF1ADC1L and AIF1ADC1R volume to be updated simultaneously
	7:0	AIF1ADC1L_VOL [7:0]	1100_0000	AIF1ADC (Left) output path Digital Volume 00h = MUTE 01h = -71.625dB ... (0.375dB steps) EFh = +17.625dB

Register 0400h AIF1 ADC1 Left Volume

REGISTER ADDRESS	BIT	LABEL	DEFAULT	DESCRIPTION
R1025 (0401h) AIF1 ADC1 Right Volume	8	AIF1ADC1_VU	0	AIF1ADC output path Volume Update Writing a 1 to this bit will cause the AIF1ADC1L and AIF1ADC1R volume to be updated simultaneously
	7:0	AIF1ADC1R_VOL [7:0]	1100_0000	AIF1ADC (Right) output path Digital Volume 00h = MUTE 01h = -71.625dB ... (0.375dB steps) EFh = +17.625dB

Register 0401h AIF1 ADC1 Right Volume

REGISTER ADDRESS	BIT	LABEL	DEFAULT	DESCRIPTION
R1026 (0402h) AIF1 DAC1 Left Volume	8	AIF1DAC1_VU	0	AIF1DAC input path Volume Update Writing a 1 to this bit will cause the AIF1DAC1L and AIF1DAC1R volume to be updated simultaneously
	7:0	AIF1DAC1L_VOL [7:0]	1100_0000	AIF1DAC (Left) input path Digital Volume 00h = MUTE 01h = -71.625dB ... (0.375dB steps) C0h = 0dB FFh = 0dB

Register 0402h AIF1 DAC1 Left Volume

REGISTER ADDRESS	BIT	LABEL	DEFAULT	DESCRIPTION
R1027 (0403h) AIF1 DAC1 Right Volume	8	AIF1DAC1_VU	0	AIF1DAC input path Volume Update Writing a 1 to this bit will cause the AIF1DAC1L and AIF1DAC1R volume to be updated simultaneously
	7:0	AIF1DAC1R_VOL [7:0]	1100_0000	AIF1DAC (Right) input path Digital Volume 00h = MUTE 01h = -71.625dB ... (0.375dB steps) C0h = 0dB FFh = 0dB

Register 0403h AIF1 DAC1 Right Volume

REGISTER ADDRESS	BIT	LABEL	DEFAULT	DESCRIPTION
R1040 (0410h) AIF1 ADC1 Filters	15	AIF1ADC_4FS	0	Enable AIF1ADC ultrasonic mode (4FS) output, bypassing all AIF1 baseband output filtering 0 = Disabled 1 = Enabled
	14:13	AIF1ADC1_HPF_CUT [1:0]	00	AIF1ADC output path Digital HPF cut-off frequency (fc) 00 = Hi-fi mode (fc = 4Hz at fs = 48kHz) 01 = Voice mode 1 (fc = 64Hz at fs = 8kHz) 10 = Voice mode 2 (fc = 130Hz at fs = 8kHz) 11 = Voice mode 3 (fc = 267Hz at fs = 8kHz)

REGISTER ADDRESS	BIT	LABEL	DEFAULT	DESCRIPTION
	12	AIF1ADC1L_HPF	0	AIF1ADC (Left) output path Digital HPF Enable 0 = Disabled 1 = Enabled
	11	AIF1ADC1R_HPF	0	AIF1ADC (Right) output path Digital HPF Enable 0 = Disabled 1 = Enabled

Register 0410h AIF1 ADC1 Filters

REGISTER ADDRESS	BIT	LABEL	DEFAULT	DESCRIPTION
R1056 (0420h) AIF1 DAC1 Filters (1)	9	AIF1DAC1_MUTE	1	AIF1DAC input path Soft Mute Control 0 = Un-mute 1 = Mute
	7	AIF1DAC1_MON O	0	AIF1DAC input path Mono Mix Control 0 = Disabled 1 = Enabled
	5	AIF1DAC1_MUTE RATE	0	AIF1DAC input path Soft Mute Ramp Rate 0 = Fast ramp (fs/2, maximum ramp time is 10.7ms at fs=48k) 1 = Slow ramp (fs/32, maximum ramp time is 171ms at fs=48k) (Note: ramp rate scales with sample rate.)
	4	AIF1DAC1_UNM UTE_RAMP	0	AIF1DAC input path Unmute Ramp select 0 = Unmuting the AIF1DAC path (AIF1DAC1_MUTE=0) will immediately apply the AIF1DAC1L_VOL and AIF1DAC1R_VOL settings. 1 = Unmuting the AIF1DAC path (AIF1DAC1_MUTE=0) will cause a gradual volume ramp up to the AIF1DAC1L_VOL and AIF1DAC1R_VOL settings.

Register 0420h AIF1 DAC1 Filters (1)

REGISTER ADDRESS	BIT	LABEL	DEFAULT	DESCRIPTION
R1057 (0421h) AIF1 DAC1 Filters (2)	13:9	AIF1DAC1_3D_G AIN [4:0]	0_0000	AIF1DAC playback path 3D Stereo depth 00000 = Off 00001 = Minimum (-16dB) ...(0.915dB steps) 11111 = Maximum (+11.45dB)
	8	AIF1DAC1_3D_E NA	0	Enable 3D Stereo in AIF1DAC playback path 0 = Disabled 1 = Enabled

Register 0421h AIF1 DAC1 Filters (2)

REGISTER ADDRESS	BIT	LABEL	DEFAULT	DESCRIPTION
R1072 (0430h) AIF1 DAC1 Noise Gate	6:5	AIF1DAC1_NG_H LD [1:0]	11	AIF1DAC input path Noise Gate Hold Time (delay before noise gate is activated) 00 = 30ms 01 = 125ms 10 = 250ms 11 = 500ms

REGISTER ADDRESS	BIT	LABEL	DEFAULT	DESCRIPTION
	3:1	AIF1DAC1_NG_THR [2:0]	100	AIF1DAC input path Noise Gate Threshold 000 = -60dB 001 = -66dB 010 = -72dB 011 = -78dB 100 = -84dB 101 = -90dB 110 = -96dB 111 = -102dB
	0	AIF1DAC1_NG_ENA	0	AIF1DAC input path Noise Gate Enable 0 = Disabled 1 = Enabled

Register 0430h AIF1 DAC1 Noise Gate

REGISTER ADDRESS	BIT	LABEL	DEFAULT	DESCRIPTION
R1088 (0440h) AIF1 DRC1 (1)	15:11	AIF1DRC1_SIG_DET_RMS [4:0]	0_0000	AIF1 DRC Signal Detect RMS Threshold. This is the RMS signal level for signal detect to be indicated when AIF1DRC1_SIG_DET_MODE=1. 00000 = -30dB 00001 = -31.5dB .... (1.5dB steps) 11110 = -75dB 11111 = -76.5dB
	10:9	AIF1DRC1_SIG_DET_PK [1:0]	00	AIF1 DRC Signal Detect Peak Threshold. This is the Peak/RMS ratio, or Crest Factor, level for signal detect to be indicated when AIF1DRC1_SIG_DET_MODE=0. 00 = 12dB 01 = 18dB 10 = 24dB 11 = 30dB
	8	AIF1DRC1_NG_ENA	0	AIF1 DRC Noise Gate Enable 0 = Disabled 1 = Enabled
	7	AIF1DRC1_SIG_DET_MODE	1	AIF1 DRC Signal Detect Mode 0 = Peak threshold mode 1 = RMS threshold mode
	6	AIF1DRC1_SIG_DET	0	AIF1 DRC Signal Detect Enable 0 = Disabled 1 = Enabled
	5	AIF1DRC1_KNEE2_OP_ENA	0	AIF1 DRC KNEE2_OP Enable 0 = Disabled 1 = Enabled
	4	AIF1DRC1_QR	1	AIF1 DRC Quick-release Enable 0 = Disabled 1 = Enabled
	3	AIF1DRC1_ANTI_CLIP	1	AIF1 DRC Anti-clip Enable 0 = Disabled 1 = Enabled
	2	AIF1DAC1_DRC_ENA	0	Enable DRC in AIF1DAC playback path 0 = Disabled

REGISTER ADDRESS	BIT	LABEL	DEFAULT	DESCRIPTION
				1 = Enabled
	1	AIF1ADC1L_DRC_ENA	0	Enable DRC in AIF1ADC (Left) record path 0 = Disabled 1 = Enabled
	0	AIF1ADC1R_DRC_ENA	0	Enable DRC in AIF1ADC (Right) record path 0 = Disabled 1 = Enabled

Register 0440h AIF1 DRC1 (1)

REGISTER ADDRESS	BIT	LABEL	DEFAULT	DESCRIPTION
R1089 (0441h) AIF1 DRC1 (2)	12:9	AIF1DRC1_ATK [3:0]	0100	AIF1 DRC Gain attack rate (seconds/6dB) 0000 = Reserved 0001 = 181us 0010 = 363us 0011 = 726us 0100 = 1.45ms 0101 = 2.9ms 0110 = 5.8ms 0111 = 11.6ms 1000 = 23.2ms 1001 = 46.4ms 1010 = 92.8ms 1011 = 185.6ms 1100-1111 = Reserved
	8:5	AIF1DRC1_DCY [3:0]	0010	AIF1 DRC Gain decay rate (seconds/6dB) 0000 = 186ms 0001 = 372ms 0010 = 743ms 0011 = 1.49s 0100 = 2.97s 0101 = 5.94s 0110 = 11.89s 0111 = 23.78s 1000 = 47.56s 1001-1111 = Reserved
	4:2	AIF1DRC1_MING AIN [2:0]	001	AIF1 DRC Minimum gain to attenuate audio signals 000 = 0dB 001 = -12dB (default) 010 = -18dB 011 = -24dB 100 = -36dB 101 = Reserved 11X = Reserved
	1:0	AIF1DRC1_MAX GAIN [1:0]	01	AIF1 DRC Maximum gain to boost audio signals (dB) 00 = 12dB 01 = 18dB 10 = 24dB 11 = 36dB

Register 0441h AIF1 DRC1 (2)

REGISTER ADDRESS	BIT	LABEL	DEFAULT	DESCRIPTION
R1090 (0442h) AIF1 DRC1 (3)	15:12	AIF1DRC1_NG_MINGAIN [3:0]	0000	AIF1 DRC Minimum gain to attenuate audio signals when the noise gate is active. 0000 = -36dB 0001 = -30dB 0010 = -24dB 0011 = -18dB 0100 = -12dB 0101 = -6dB 0110 = 0dB 0111 = 6dB 1000 = 12dB 1001 = 18dB 1010 = 24dB 1011 = 30dB 1100 = 36dB 1101 to 1111 = Reserved
	11:10	AIF1DRC1_NG_EXP [1:0]	00	AIF1 DRC Noise Gate slope 00 = 1 (no expansion) 01 = 2 10 = 4 11 = 8
	9:8	AIF1DRC1_QR_THR [1:0]	00	AIF1 DRC Quick-release threshold (crest factor in dB) 00 = 12dB 01 = 18dB 10 = 24dB 11 = 30dB
	7:6	AIF1DRC1_QR_DECY [1:0]	00	AIF1 DRC Quick-release decay rate (seconds/6dB) 00 = 0.725ms 01 = 1.45ms 10 = 5.8ms 11 = Reserved
	5:3	AIF1DRC1_HI_COMP [2:0]	000	AIF1 DRC Compressor slope (upper region) 000 = 1 (no compression) 001 = 1/2 010 = 1/4 011 = 1/8 100 = 1/16 101 = 0 110 = Reserved 111 = Reserved
	2:0	AIF1DRC1_LO_COMP [2:0]	000	AIF1 DRC Compressor slope (lower region) 000 = 1 (no compression) 001 = 1/2 010 = 1/4 011 = 1/8 100 = 0 101 = Reserved 110 = Reserved 111 = Reserved

Register 0442h AIF1 DRC1 (3)



REGISTER ADDRESS	BIT	LABEL	DEFAULT	DESCRIPTION
R1091 (0443h) AIF1 DRC1 (4)	10:5	AIF1DRC1_KNEE_IP [5:0]	00_0000	AIF1 DRC Input signal level at the Compressor 'Knee'. 000000 = 0dB 000001 = -0.75dB 000010 = -1.5dB ... (-0.75dB steps) 111100 = -45dB 111101 = Reserved 11111X = Reserved
	4:0	AIF1DRC1_KNEE_OP [4:0]	0_0000	AIF1 DRC Output signal at the Compressor 'Knee'. 00000 = 0dB 00001 = -0.75dB 00010 = -1.5dB ... (-0.75dB steps) 11110 = -22.5dB 11111 = Reserved

Register 0443h AIF1 DRC1 (4)

REGISTER ADDRESS	BIT	LABEL	DEFAULT	DESCRIPTION
R1092 (0444h) AIF1 DRC1 (5)	9:5	AIF1DRC1_KNEE2_IP [4:0]	0_0000	AIF1 DRC Input signal level at the Noise Gate threshold 'Knee2'. 00000 = -36dB 00001 = -37.5dB 00010 = -39dB ... (-1.5dB steps) 11110 = -81dB 11111 = -82.5dB Only applicable when AIF1DRC1_NG_ENA = 1.
	4:0	AIF1DRC1_KNEE2_OP [4:0]	0_0000	AIF1 DRC Output signal at the Noise Gate threshold 'Knee2'. 00000 = -30dB 00001 = -31.5dB 00010 = -33dB ... (-1.5dB steps) 11110 = -75dB 11111 = -76.5dB Only applicable when AIF1DRC1_KNEE2_OP_ENA = 1.

Register 0444h AIF1 DRC1 (5)

REGISTER ADDRESS	BIT	LABEL	DEFAULT	DESCRIPTION
R1152 (0480h) AIF1 DAC1 EQ Gains (1)	15:11	AIF1DAC1_EQ_B1_GAIN [4:0]	0_1100	AIF1 EQ Band 1 Gain -12dB to +12dB in 1dB steps
	10:6	AIF1DAC1_EQ_B2_GAIN [4:0]	0_1100	AIF1 EQ Band 2 Gain -12dB to +12dB in 1dB steps
	5:1	AIF1DAC1_EQ_B3_GAIN [4:0]	0_1100	AIF1 EQ Band 3 Gain -12dB to +12dB in 1dB steps
	0	AIF1DAC1_EQ_ENA	0	Enable EQ in AIF1DAC playback path 0 = Disabled 1 = Enabled

Register 0480h AIF1 DAC1 EQ Gains (1)

REGISTER ADDRESS	BIT	LABEL	DEFAULT	DESCRIPTION
R1153 (0481h) AIF1 DAC1 EQ Gains (2)	15:11	AIF1DAC1_EQ_B 4_GAIN [4:0]	0_1100	AIF1 EQ Band 4 Gain -12dB to +12dB in 1dB steps
	10:6	AIF1DAC1_EQ_B 5_GAIN [4:0]	0_1100	AIF1 EQ Band 5 Gain -12dB to +12dB in 1dB steps
	0	AIF1DAC1_EQ_M ODE	0	AIF1 EQ Band 1 Mode 0 = Shelving filter 1 = Peak filter

Register 0481h AIF1 DAC1 EQ Gains (2)

REGISTER ADDRESS	BIT	LABEL	DEFAULT	DESCRIPTION
R1154 (0482h) AIF1 DAC1 EQ Band 1 A	15:0	AIF1DAC1_EQ_B 1_A [15:0]	0000_1111_11 00_1010	EQ Band 1 Coefficient A

Register 0482h AIF1 DAC1 EQ Band 1 A

REGISTER ADDRESS	BIT	LABEL	DEFAULT	DESCRIPTION
R1155 (0483h) AIF1 DAC1 EQ Band 1 B	15:0	AIF1DAC1_EQ_B 1_B [15:0]	0000_0100_00 00_0000	EQ Band 1 Coefficient B

Register 0483h AIF1 DAC1 EQ Band 1 B

REGISTER ADDRESS	BIT	LABEL	DEFAULT	DESCRIPTION
R1156 (0484h) AIF1 DAC1 EQ Band 1 PG	15:0	AIF1DAC1_EQ_B 1_PG [15:0]	0000_0000_11 01_1000	EQ Band 1 Coefficient PG

Register 0484h AIF1 DAC1 EQ Band 1 PG

REGISTER ADDRESS	BIT	LABEL	DEFAULT	DESCRIPTION
R1157 (0485h) AIF1 DAC1 EQ Band 2 A	15:0	AIF1DAC1_EQ_B 2_A [15:0]	0001_1110_10 11_0101	EQ Band 2 Coefficient A

Register 0485h AIF1 DAC1 EQ Band 2 A

REGISTER ADDRESS	BIT	LABEL	DEFAULT	DESCRIPTION
R1158 (0486h) AIF1 DAC1 EQ Band 2 B	15:0	AIF1DAC1_EQ_B 2_B [15:0]	1111_0001_01 00_0101	EQ Band 2 Coefficient B

Register 0486h AIF1 DAC1 EQ Band 2 B

REGISTER ADDRESS	BIT	LABEL	DEFAULT	DESCRIPTION
R1159 (0487h) AIF1 DAC1 EQ Band 2 C	15:0	AIF1DAC1_EQ_B 2_C [15:0]	0000_1011_01 11_0101	EQ Band 2 Coefficient C

Register 0487h AIF1 DAC1 EQ Band 2 C

REGISTER ADDRESS	BIT	LABEL	DEFAULT	DESCRIPTION
R1160 (0488h) AIF1 DAC1 EQ Band 2 PG	15:0	AIF1DAC1_EQ_B 2_PG [15:0]	0000_0001_11 00_0101	EQ Band 2 Coefficient PG

Register 0488h AIF1 DAC1 EQ Band 2 PG

REGISTER ADDRESS	BIT	LABEL	DEFAULT	DESCRIPTION
R1161 (0489h) AIF1 DAC1 EQ Band 3 A	15:0	AIF1DAC1_EQ_B 3_A [15:0]	0001_1100_01 01_1000	EQ Band 3 Coefficient A

Register 0489h AIF1 DAC1 EQ Band 3 A

REGISTER ADDRESS	BIT	LABEL	DEFAULT	DESCRIPTION
R1162 (048Ah) AIF1 DAC1 EQ Band 3 B	15:0	AIF1DAC1_EQ_B 3_B [15:0]	1111_0011_01 11_0011	EQ Band 3 Coefficient B

Register 048Ah AIF1 DAC1 EQ Band 3 B

REGISTER ADDRESS	BIT	LABEL	DEFAULT	DESCRIPTION
R1163 (048Bh) AIF1 DAC1 EQ Band 3 C	15:0	AIF1DAC1_EQ_B 3_C [15:0]	0000_1010_01 01_0100	EQ Band 3 Coefficient C

Register 048Bh AIF1 DAC1 EQ Band 3 C

REGISTER ADDRESS	BIT	LABEL	DEFAULT	DESCRIPTION
R1164 (048Ch) AIF1 DAC1 EQ Band 3 PG	15:0	AIF1DAC1_EQ_B 3_PG [15:0]	0000_0101_01 01_1000	EQ Band 3 Coefficient PG

Register 048Ch AIF1 DAC1 EQ Band 3 PG

REGISTER ADDRESS	BIT	LABEL	DEFAULT	DESCRIPTION
R1165 (048Dh) AIF1 DAC1 EQ Band 4 A	15:0	AIF1DAC1_EQ_B 4_A [15:0]	0001_0110_10 00_1110	EQ Band 4 Coefficient A

Register 048Dh AIF1 DAC1 EQ Band 4 A

REGISTER ADDRESS	BIT	LABEL	DEFAULT	DESCRIPTION
R1166 (048Eh) AIF1 DAC1 EQ Band 4 B	15:0	AIF1DAC1_EQ_B 4_B [15:0]	1111_1000_00 10_1001	EQ Band 4 Coefficient B

Register 048Eh AIF1 DAC1 EQ Band 4 B

REGISTER ADDRESS	BIT	LABEL	DEFAULT	DESCRIPTION
R1167 (048Fh) AIF1 DAC1 EQ Band 4 C	15:0	AIF1DAC1_EQ_B 4_C [15:0]	0000_0111_10 10_1101	EQ Band 4 Coefficient C

Register 048Fh AIF1 DAC1 EQ Band 4 C

REGISTER ADDRESS	BIT	LABEL	DEFAULT	DESCRIPTION
R1168 (0490h) AIF1 DAC1 EQ Band 4 PG	15:0	AIF1DAC1_EQ_B 4_PG [15:0]	0001_0001_00 00_0011	EQ Band 4 Coefficient PG

Register 0490h AIF1 DAC1 EQ Band 4 PG

REGISTER ADDRESS	BIT	LABEL	DEFAULT	DESCRIPTION
R1169 (0491h) AIF1 DAC1 EQ Band 5 A	15:0	AIF1DAC1_EQ_B 5_A [15:0]	0000_0101_01 10_0100	EQ Band 5 Coefficient A

Register 0491h AIF1 DAC1 EQ Band 5 A

REGISTER ADDRESS	BIT	LABEL	DEFAULT	DESCRIPTION
R1170 (0492h) AIF1 DAC1 EQ Band 5 B	15:0	AIF1DAC1_EQ_B 5_B [15:0]	0000_0101_01 01_1001	EQ Band 5 Coefficient B

Register 0492h AIF1 DAC1 EQ Band 5 B

REGISTER ADDRESS	BIT	LABEL	DEFAULT	DESCRIPTION
R1171 (0493h) AIF1 DAC1 EQ Band 5 PG	15:0	AIF1DAC1_EQ_B 5_PG [15:0]	0100_0000_00 00_0000	EQ Band 5 Coefficient PG

Register 0493h AIF1 DAC1 EQ Band 5 PG

REGISTER ADDRESS	BIT	LABEL	DEFAULT	DESCRIPTION
R1172 (0494h) AIF1 DAC1 EQ Band 1 C	15:0	AIF1DAC1_EQ_B 1_C [15:0]	0000_0000_00 00_0000	EQ Band 1 Coefficient C

Register 0494h AIF1 DAC1 EQ Band 1 C

REGISTER ADDRESS	BIT	LABEL	DEFAULT	DESCRIPTION
R1280 (0500h) AIF2 ADC Left Volume	8	AIF2ADC_VU	0	AIF2ADC output path Volume Update Writing a 1 to this bit will cause the AIF2ADCL and AIF2ADCR volume to be updated simultaneously
	7:0	AIF2ADCL_VOL [7:0]	1100_0000	AIF2ADC (Left) output path Digital Volume 00h = MUTE 01h = -71.625dB ... (0.375dB steps) EFh = +17.625dB

Register 0500h AIF2 ADC Left Volume

REGISTER ADDRESS	BIT	LABEL	DEFAULT	DESCRIPTION
R1281 (0501h) AIF2 ADC Right Volume	8	AIF2ADC_VU	0	AIF2ADC output path Volume Update Writing a 1 to this bit will cause the AIF2ADCL and AIF2ADCR volume to be updated simultaneously
	7:0	AIF2ADCR_VOL [7:0]	1100_0000	AIF2ADC (Right) output path Digital Volume 00h = MUTE 01h = -71.625dB ... (0.375dB steps) EFh = +17.625dB

Register 0501h AIF2 ADC Right Volume

REGISTER ADDRESS	BIT	LABEL	DEFAULT	DESCRIPTION
R1282 (0502h) AIF2 DAC Left Volume	8	AIF2DAC_VU	0	AIF2DAC input path Volume Update Writing a 1 to this bit will cause the AIF2DACL and AIF2DACR volume to be updated simultaneously
	7:0	AIF2DACL_VOL [7:0]	1100_0000	AIF2DAC (Left) input path Digital Volume 00h = MUTE 01h = -71.625dB ... (0.375dB steps) C0h = 0dB FFh = 0dB

Register 0502h AIF2 DAC Left Volume

REGISTER ADDRESS	BIT	LABEL	DEFAULT	DESCRIPTION
R1283 (0503h) AIF2 DAC Right Volume	8	AIF2DAC_VU	0	AIF2DAC input path Volume Update Writing a 1 to this bit will cause the AIF2DACL and AIF2DACR volume to be updated simultaneously
	7:0	AIF2DACR_VOL [7:0]	1100_0000	AIF2DAC (Right) input path Digital Volume 00h = MUTE 01h = -71.625dB ... (0.375dB steps) C0h = 0dB FFh = 0dB

Register 0503h AIF2 DAC Right Volume

REGISTER ADDRESS	BIT	LABEL	DEFAULT	DESCRIPTION
R1296 (0510h) AIF2 ADC Filters	14:13	AIF2ADC_HPF_C UT [1:0]	00	AIF2ADC output path Digital HPF Cut-Off Frequency (fc) 00 = Hi-fi mode (fc = 4Hz at fs = 48kHz) 01 = Voice mode 1 (fc = 127Hz at fs = 8kHz) 10 = Voice mode 2 (fc = 130Hz at fs = 8kHz) 11 = Voice mode 3 (fc = 267Hz at fs = 8kHz)
	12	AIF2ADCL_HPF	0	AIF2ADC (Left) output path Digital HPF Enable 0 = Disabled 1 = Enabled
	11	AIF2ADCR_HPF	0	AIF2ADC (Right) output path Digital HPF Enable 0 = Disabled 1 = Enabled

Register 0510h AIF2 ADC Filters

REGISTER ADDRESS	BIT	LABEL	DEFAULT	DESCRIPTION
R1312 (0520h) AIF2 DAC Filters (1)	9	AIF2DAC_MUTE	1	AIF2DAC input path Soft Mute Control 0 = Un-mute 1 = Mute
	7	AIF2DAC_MONO	0	AIF2DAC input path Mono Mix Control 0 = Disabled 1 = Enabled

REGISTER ADDRESS	BIT	LABEL	DEFAULT	DESCRIPTION
	5	AIF2DAC_MUTE_RATE	0	AIF2DAC input path Soft Mute Ramp Rate 0 = Fast ramp (fs/2, maximum ramp time is 10.7ms at fs=48k) 1 = Slow ramp (fs/32, maximum ramp time is 171ms at fs=48k) (Note: ramp rate scales with sample rate.)
	4	AIF2DAC_UNMUTE_RAMP	0	AIF2DAC input path Unmute Ramp select 0 = Unmuting the AIF2DAC path (AIF2DAC_MUTE=0) will immediately apply the AIF2DACL_VOL and AIF2DACR_VOL settings. 1 = Unmuting the AIF2DAC path (AIF2DAC_MUTE=0) will cause a gradual volume ramp up to the AIF2DACL_VOL and AIF2DACR_VOL settings.

Register 0520h AIF2 DAC Filters (1)

REGISTER ADDRESS	BIT	LABEL	DEFAULT	DESCRIPTION
R1313 (0521h) AIF2 DAC Filters (2)	13:9	AIF2DAC_3D_GAIN [4:0]	0_0000	AIF2DAC playback path 3D Stereo depth 00000 = Off 00001 = Minimum (-16dB) ...(0.915dB steps) 11111 = Maximum (+11.45dB)
	8	AIF2DAC_3D_ENA	0	Enable 3D Stereo in AIF2DAC playback path 0 = Disabled 1 = Enabled

Register 0521h AIF2 DAC Filters (2)

REGISTER ADDRESS	BIT	LABEL	DEFAULT	DESCRIPTION
R1328 (0530h) AIF2 DAC Noise Gate	6:5	AIF2DAC_NG_HOLD [1:0]	11	AIF2DAC input path Noise Gate Hold Time (delay before noise gate is activated) 00 = 30ms 01 = 125ms 10 = 250ms 11 = 500ms
	3:1	AIF2DAC_NG_THRESHOLD [2:0]	100	AIF2DAC input path Noise Gate Threshold 000 = -60dB 001 = -66dB 010 = -72dB 011 = -78dB 100 = -84dB 101 = -90dB 110 = -96dB 111 = -102dB
	0	AIF2DAC_NG_ENABLE	0	AIF2DAC input path Noise Gate Enable 0 = Disabled 1 = Enabled

Register 0530h AIF2 DAC Noise Gate

REGISTER ADDRESS	BIT	LABEL	DEFAULT	DESCRIPTION
R1344 (0540h) AIF2 DRC (1)	15:11	AIF2DRC_SIG_DET_RMS [4:0]	0_0000	AIF2 DRC Signal Detect RMS Threshold. This is the RMS signal level for signal detect to be indicated when AIF2DRC_SIG_DET_MODE=1. 00000 = -30dB 00001 = -31.5dB .... (1.5dB steps) 11110 = -75dB 11111 = -76.5dB
	10:9	AIF2DRC_SIG_DET_PK [1:0]	00	AIF2 DRC Signal Detect Peak Threshold. This is the Peak/RMS ratio, or Crest Factor, level for signal detect to be indicated when AIF2DRC_SIG_DET_MODE=0. 00 = 12dB 01 = 18dB 10 = 24dB 11 = 30dB
	8	AIF2DRC_NG_ENA	0	AIF2 DRC Noise Gate Enable 0 = Disabled 1 = Enabled
	7	AIF2DRC_SIG_DET_MODE	1	AIF2 DRC Signal Detect Mode 0 = Peak threshold mode 1 = RMS threshold mode
	6	AIF2DRC_SIG_DET	0	AIF2 DRC Signal Detect Enable 0 = Disabled 1 = Enabled
	5	AIF2DRC_KNEE2_OP_ENA	0	AIF2 DRC KNEE2_OP Enable 0 = Disabled 1 = Enabled
	4	AIF2DRC_QR	1	AIF2 DRC Quick-release Enable 0 = Disabled 1 = Enabled
	3	AIF2DRC_ANTICLIP	1	AIF2 DRC Anti-clip Enable 0 = Disabled 1 = Enabled
	2	AIF2DAC_DRC_ENA	0	Enable DRC in AIF2DAC playback path 0 = Disabled 1 = Enabled
	1	AIF2ADCL_DRC_ENA	0	Enable DRC in AIF2ADC (Left) record path 0 = Disabled 1 = Enabled
0	AIF2ADCR_DRC_ENA	0	Enable DRC in AIF2ADC (Right) record path 0 = Disabled 1 = Enabled	

Register 0540h AIF2 DRC (1)



REGISTER ADDRESS	BIT	LABEL	DEFAULT	DESCRIPTION
R1345 (0541h) AIF2 DRC (2)	12:9	AIF2DRC_ATK [3:0]	0100	AIF2 DRC Gain attack rate (seconds/6dB) 0000 = Reserved 0001 = 181us 0010 = 363us 0011 = 726us 0100 = 1.45ms 0101 = 2.9ms 0110 = 5.8ms 0111 = 11.6ms 1000 = 23.2ms 1001 = 46.4ms 1010 = 92.8ms 1011 = 185.6ms 1100-1111 = Reserved
	8:5	AIF2DRC_DCY [3:0]	0010	AIF2 DRC Gain decay rate (seconds/6dB) 0000 = 186ms 0001 = 372ms 0010 = 743ms 0011 = 1.49s 0100 = 2.97s 0101 = 5.94s 0110 = 11.89s 0111 = 23.78s 1000 = 47.56s 1001-1111 = Reserved
	4:2	AIF2DRC_MINGA IN [2:0]	001	AIF2 DRC Minimum gain to attenuate audio signals 000 = 0dB 001 = -12dB (default) 010 = -18dB 011 = -24dB 100 = -36dB 101 = Reserved 11X = Reserved
	1:0	AIF2DRC_MAXG AIN [1:0]	01	AIF2 DRC Maximum gain to boost audio signals (dB) 00 = 12dB 01 = 18dB 10 = 24dB 11 = 36dB

Register 0541h AIF2 DRC (2)

REGISTER ADDRESS	BIT	LABEL	DEFAULT	DESCRIPTION
R1346 (0542h) AIF2 DRC (3)	15:12	AIF2DRC_NG_MI NGAIN [3:0]	0000	AIF2 DRC Minimum gain to attenuate audio signals when the noise gate is active. 0000 = -36dB 0001 = -30dB 0010 = -24dB 0011 = -18dB 0100 = -12dB 0101 = -6dB 0110 = 0dB

REGISTER ADDRESS	BIT	LABEL	DEFAULT	DESCRIPTION
				0111 = 6dB 1000 = 12dB 1001 = 18dB 1010 = 24dB 1011 = 30dB 1100 = 36dB 1101 to 1111 = Reserved
	11:10	AIF2DRC_NG_EXP [1:0]	00	AIF2 DRC Noise Gate slope 00 = 1 (no expansion) 01 = 2 10 = 4 11 = 8
	9:8	AIF2DRC_QR_THR [1:0]	00	AIF2 DRC Quick-release threshold (crest factor in dB) 00 = 12dB 01 = 18dB 10 = 24dB 11 = 30dB
	7:6	AIF2DRC_QR_DECY [1:0]	00	AIF2 DRC Quick-release decay rate (seconds/6dB) 00 = 0.725ms 01 = 1.45ms 10 = 5.8ms 11 = Reserved
	5:3	AIF2DRC_HI_COMP [2:0]	000	AIF2 DRC Compressor slope (upper region) 000 = 1 (no compression) 001 = 1/2 010 = 1/4 011 = 1/8 100 = 1/16 101 = 0 110 = Reserved 111 = Reserved
	2:0	AIF2DRC_LO_COMP [2:0]	000	AIF2 DRC Compressor slope (lower region) 000 = 1 (no compression) 001 = 1/2 010 = 1/4 011 = 1/8 100 = 0 101 = Reserved 110 = Reserved 111 = Reserved

Register 0542h AIF2 DRC (3)

REGISTER ADDRESS	BIT	LABEL	DEFAULT	DESCRIPTION
R1347 (0543h) AIF2 DRC (4)	10:5	AIF2DRC_KNEE_IP [5:0]	00_0000	AIF2 DRC Input signal level at the Compressor 'Knee'. 000000 = 0dB 000001 = -0.75dB 000010 = -1.5dB ... (-0.75dB steps) 111100 = -45dB 111101 = Reserved 11111X = Reserved

REGISTER ADDRESS	BIT	LABEL	DEFAULT	DESCRIPTION
	4:0	AIF2DRC_KNEE_OP [4:0]	0_0000	AIF2 DRC Output signal at the Compressor 'Knee'. 00000 = 0dB 00001 = -0.75dB 00010 = -1.5dB ... (-0.75dB steps) 11110 = -22.5dB 11111 = Reserved

Register 0543h AIF2 DRC (4)

REGISTER ADDRESS	BIT	LABEL	DEFAULT	DESCRIPTION
R1348 (0544h) AIF2 DRC (5)	9:5	AIF2DRC_KNEE2_IP [4:0]	0_0000	AIF2 DRC Input signal level at the Noise Gate threshold 'Knee2'. 00000 = -36dB 00001 = -37.5dB 00010 = -39dB ... (-1.5dB steps) 11110 = -81dB 11111 = -82.5dB Only applicable when AIF2DRC_NG_ENA = 1.
	4:0	AIF2DRC_KNEE2_OP [4:0]	0_0000	AIF2 DRC Output signal at the Noise Gate threshold 'Knee2'. 00000 = -30dB 00001 = -31.5dB 00010 = -33dB ... (-1.5dB steps) 11110 = -75dB 11111 = -76.5dB Only applicable when AIF2DRC_KNEE2_OP_ENA = 1.

Register 0544h AIF2 DRC (5)

REGISTER ADDRESS	BIT	LABEL	DEFAULT	DESCRIPTION
R1408 (0580h) AIF2 EQ Gains (1)	15:11	AIF2DAC_EQ_B1_GAIN [4:0]	0_1100	AIF2 EQ Band 1 Gain -12dB to +12dB in 1dB steps
	10:6	AIF2DAC_EQ_B2_GAIN [4:0]	0_1100	AIF2EQ Band 2 Gain -12dB to +12dB in 1dB steps
	5:1	AIF2DAC_EQ_B3_GAIN [4:0]	0_1100	AIF2EQ Band 3 Gain -12dB to +12dB in 1dB steps
	0	AIF2DAC_EQ_ENA	0	Enable EQ in AIF2DAC playback path 0 = Disabled 1 = Enabled

Register 0580h AIF2 EQ Gains (1)

REGISTER ADDRESS	BIT	LABEL	DEFAULT	DESCRIPTION
R1409 (0581h) AIF2 EQ Gains (2)	15:11	AIF2DAC_EQ_B4_GAIN [4:0]	0_1100	AIF2EQ Band 4 Gain -12dB to +12dB in 1dB steps
	10:6	AIF2DAC_EQ_B5_GAIN [4:0]	0_1100	AIF2EQ Band 5 Gain -12dB to +12dB in 1dB steps

REGISTER ADDRESS	BIT	LABEL	DEFAULT	DESCRIPTION
	0	AIF2DAC_EQ_MODE	0	AIF2 EQ Band 1 Mode 0 = Shelving filter 1 = Peak filter

Register 0581h AIF2 EQ Gains (2)

REGISTER ADDRESS	BIT	LABEL	DEFAULT	DESCRIPTION
R1410 (0582h) AIF2 EQ Band 1 A	15:0	AIF2DAC_EQ_B1_A [15:0]	0000_1111_1100_1010	EQ Band 1 Coefficient A

Register 0582h AIF2 EQ Band 1 A

REGISTER ADDRESS	BIT	LABEL	DEFAULT	DESCRIPTION
R1411 (0583h) AIF2 EQ Band 1 B	15:0	AIF2DAC_EQ_B1_B [15:0]	0000_0100_0000_0000	EQ Band 1 Coefficient B

Register 0583h AIF2 EQ Band 1 B

REGISTER ADDRESS	BIT	LABEL	DEFAULT	DESCRIPTION
R1412 (0584h) AIF2 EQ Band 1 PG	15:0	AIF2DAC_EQ_B1_PG [15:0]	0000_0000_1101_1000	EQ Band 1 Coefficient PG

Register 0584h AIF2 EQ Band 1 PG

REGISTER ADDRESS	BIT	LABEL	DEFAULT	DESCRIPTION
R1413 (0585h) AIF2 EQ Band 2 A	15:0	AIF2DAC_EQ_B2_A [15:0]	0001_1110_1011_0101	EQ Band 2 Coefficient A

Register 0585h AIF2 EQ Band 2 A

REGISTER ADDRESS	BIT	LABEL	DEFAULT	DESCRIPTION
R1414 (0586h) AIF2 EQ Band 2 B	15:0	AIF2DAC_EQ_B2_B [15:0]	1111_0001_0100_0101	EQ Band 2 Coefficient B

Register 0586h AIF2 EQ Band 2 B

REGISTER ADDRESS	BIT	LABEL	DEFAULT	DESCRIPTION
R1415 (0587h) AIF2 EQ Band 2 C	15:0	AIF2DAC_EQ_B2 _C [15:0]	0000_1011_01 11_0101	EQ Band 2 Coefficient C

**Register 0587h** AIF2 EQ Band 2 C

REGISTER ADDRESS	BIT	LABEL	DEFAULT	DESCRIPTION
R1416 (0588h) AIF2 EQ Band 2 PG	15:0	AIF2DAC_EQ_B2 _PG [15:0]	0000_0001_11 00_0101	EQ Band 2 Coefficient PG

**Register 0588h** AIF2 EQ Band 2 PG

REGISTER ADDRESS	BIT	LABEL	DEFAULT	DESCRIPTION
R1417 (0589h) AIF2 EQ Band 3 A	15:0	AIF2DAC_EQ_B3 _A [15:0]	0001_1100_01 01_1000	EQ Band 3 Coefficient A

**Register 0589h** AIF2 EQ Band 3 A

REGISTER ADDRESS	BIT	LABEL	DEFAULT	DESCRIPTION
R1418 (058Ah) AIF2 EQ Band 3 B	15:0	AIF2DAC_EQ_B3 _B [15:0]	1111_0011_01 11_0011	EQ Band 3 Coefficient B

**Register 058Ah** AIF2 EQ Band 3 B

REGISTER ADDRESS	BIT	LABEL	DEFAULT	DESCRIPTION
R1419 (058Bh) AIF2 EQ Band 3 C	15:0	AIF2DAC_EQ_B3 _C [15:0]	0000_1010_01 01_0100	EQ Band 3 Coefficient C

**Register 058Bh** AIF2 EQ Band 3 C

REGISTER ADDRESS	BIT	LABEL	DEFAULT	DESCRIPTION
R1420 (058Ch) AIF2 EQ Band 3 PG	15:0	AIF2DAC_EQ_B3 _PG [15:0]	0000_0101_01 01_1000	EQ Band 3 Coefficient PG

**Register 058Ch** AIF2 EQ Band 3 PG

REGISTER ADDRESS	BIT	LABEL	DEFAULT	DESCRIPTION
R1421 (058Dh) AIF2 EQ Band 4 A	15:0	AIF2DAC_EQ_B4 _A [15:0]	0001_0110_10 00_1110	EQ Band 4 Coefficient A

Register 058Dh AIF2 EQ Band 4 A

REGISTER ADDRESS	BIT	LABEL	DEFAULT	DESCRIPTION
R1422 (058Eh) AIF2 EQ Band 4 B	15:0	AIF2DAC_EQ_B4 _B [15:0]	1111_1000_00 10_1001	EQ Band 4 Coefficient B

Register 058Eh AIF2 EQ Band 4 B

REGISTER ADDRESS	BIT	LABEL	DEFAULT	DESCRIPTION
R1423 (058Fh) AIF2 EQ Band 4 C	15:0	AIF2DAC_EQ_B4 _C [15:0]	0000_0111_10 10_1101	EQ Band 4 Coefficient C

Register 058Fh AIF2 EQ Band 4 C

REGISTER ADDRESS	BIT	LABEL	DEFAULT	DESCRIPTION
R1424 (0590h) AIF2 EQ Band 4 PG	15:0	AIF2DAC_EQ_B4 _PG [15:0]	0001_0001_00 00_0011	EQ Band 4 Coefficient PG

Register 0590h AIF2 EQ Band 4 PG

REGISTER ADDRESS	BIT	LABEL	DEFAULT	DESCRIPTION
R1425 (0591h) AIF2 EQ Band 5 A	15:0	AIF2DAC_EQ_B5 _A [15:0]	0000_0101_01 10_0100	EQ Band 5 Coefficient A

Register 0591h AIF2 EQ Band 5 A

REGISTER ADDRESS	BIT	LABEL	DEFAULT	DESCRIPTION
R1426 (0592h) AIF2 EQ Band 5 B	15:0	AIF2DAC_EQ_B5 _B [15:0]	0000_0101_01 01_1001	EQ Band 5 Coefficient B

Register 0592h AIF2 EQ Band 5 B

REGISTER ADDRESS	BIT	LABEL	DEFAULT	DESCRIPTION
R1427 (0593h) AIF2 EQ Band 5 PG	15:0	AIF2DAC_EQ_B5 _PG [15:0]	0100_0000_00 00_0000	EQ Band 5 Coefficient PG

Register 0593h AIF2 EQ Band 5 PG

REGISTER ADDRESS	BIT	LABEL	DEFAULT	DESCRIPTION
R1428 (0594h) AIF2 EQ Band 1 C	15:0	AIF2DAC_EQ_B1 _C [15:0]	0000_0000_00 00_0000	EQ Band 1 Coefficient C

Register 0594h AIF2 EQ Band 1 C

REGISTER ADDRESS	BIT	LABEL	DEFAULT	DESCRIPTION
R1536 (0600h) DAC1 Mixer Volumes	8:5	ADCR_DAC1_VO L [3:0]	0000	Sidetone STR to DAC1L and DAC1R Volume 0000 = -36dB 0001 = -33dB .... (3dB steps) 1011 = -3dB 1100 = 0dB
	3:0	ADCL_DAC1_VO L [3:0]	0000	Sidetone STL to DAC1L and DAC1R Volume 0000 = -36dB 0001 = -33dB .... (3dB steps) 1011 = -3dB 1100 = 0dB

Register 0600h DAC1 Mixer Volumes

REGISTER ADDRESS	BIT	LABEL	DEFAULT	DESCRIPTION
R1537 (0601h) DAC1 Left Mixer Routing	5	ADCR_TO_DAC1 L	0	Enable Sidetone STR to DAC1L 0 = Disabled 1 = Enabled
	4	ADCL_TO_DAC1 L	0	Enable Sidetone STL to DAC1L 0 = Disabled 1 = Enabled
	2	AIF2DACL_TO_D AC1L	0	Enable AIF2 (Left) to DAC1L 0 = Disabled 1 = Enabled
	0	AIF1DAC1L_TO_ DAC1L	0	Enable AIF1 (Left) to DAC1L 0 = Disabled 1 = Enabled

Register 0601h DAC1 Left Mixer Routing

REGISTER ADDRESS	BIT	LABEL	DEFAULT	DESCRIPTION
R1538 (0602h) DAC1 Right Mixer Routing	5	ADCR_TO_DAC1 R	0	Enable Sidetone STR to DAC1R 0 = Disabled 1 = Enabled
	4	ADCL_TO_DAC1 R	0	Enable Sidetone STL to DAC1R 0 = Disabled 1 = Enabled
	2	AIF2DACR_TO_D AC1R	0	Enable AIF2 (Right) to DAC1R 0 = Disabled 1 = Enabled
	0	AIF1DAC1R_TO_ DAC1R	0	Enable AIF1 (Right) to DAC1R 0 = Disabled 1 = Enabled

Register 0602h DAC1 Right Mixer Routing

REGISTER ADDRESS	BIT	LABEL	DEFAULT	DESCRIPTION
R1539 (0603h) AIF2ADC Mixer Volumes	8:5	ADCR_AIF2ADC_ VOL [3:0]	0000	Sidetone STR to AIF2 Tx Volume 0000 = -36dB 0001 = -33dB .... (3dB steps) 1011 = -3dB 1100 = 0dB
	3:0	ADCL_AIF2ADC_ VOL [3:0]	0000	Sidetone STL to AIF2 Tx Volume 0000 = -36dB 0001 = -33dB .... (3dB steps) 1011 = -3dB 1100 = 0dB

Register 0603h AIF2ADC Mixer Volumes

REGISTER ADDRESS	BIT	LABEL	DEFAULT	DESCRIPTION
R1540 (0604h) AIF2ADC Left Mixer Routing	5	ADCR_TO_AIF2A DCL	0	Enable Sidetone STR to AIF2 Tx (Left) 0 = Disabled 1 = Enabled
	4	ADCL_TO_AIF2A DCL	0	Enable Sidetone STL to AIF2 Tx (Left) 0 = Disabled 1 = Enabled
	2	AIF2DACL_TO_A IF2ADCL	0	Enable AIF2 (Left) to AIF2 Tx (Left) 0 = Disabled 1 = Enabled
	0	AIF1DAC1L_TO_ AIF2ADCL	0	Enable AIF1 (Left) to AIF2 Tx (Left) 0 = Disabled 1 = Enabled

Register 0604h AIF2ADC Left Mixer Routing



REGISTER ADDRESS	BIT	LABEL	DEFAULT	DESCRIPTION
R1541 (0605h) AIF2ADC Right Mixer Routing	5	ADCR_TO_AIF2A DCR	0	Enable Sidetone STR to AIF2 Tx (Right) 0 = Disabled 1 = Enabled
	4	ADCL_TO_AIF2A DCR	0	Enable Sidetone STL to AIF2 Tx (Right) 0 = Disabled 1 = Enabled
	2	AIF2DACR_TO_A IF2ADCR	0	Enable AIF2 (Right) to AIF2 Tx (Right) 0 = Disabled 1 = Enabled
	0	AIF1DAC1R_TO_ AIF2ADCR	0	Enable AIF1 (Right) to AIF2 Tx (Right) 0 = Disabled 1 = Enabled

Register 0605h AIF2ADC Right Mixer Routing

REGISTER ADDRESS	BIT	LABEL	DEFAULT	DESCRIPTION
R1542 (0606h) AIF1 ADC1 Left Mixer Routing	1	ADC1L_TO_AIF1 ADC1L	0	Enable ADCL / DMIC (Left) to AIF1 (Left) output 0 = Disabled 1 = Enabled
	0	AIF2DACL_TO_A IF1ADC1L	0	Enable AIF2 (Left) to AIF1 (Left) output 0 = Disabled 1 = Enabled

Register 0606h AIF1 ADC1 Left Mixer Routing

REGISTER ADDRESS	BIT	LABEL	DEFAULT	DESCRIPTION
R1543 (0607h) AIF1 ADC1 Right Mixer Routing	1	ADC1R_TO_AIF1 ADC1R	0	Enable ADCR / DMIC (Right) to AIF1 (Right) output 0 = Disabled 1 = Enabled
	0	AIF2DACR_TO_A IF1ADC1R	0	Enable AIF2 (Right) to AIF1 (Right) output 0 = Disabled 1 = Enabled

Register 0607h AIF1 ADC1 Right Mixer Routing

REGISTER ADDRESS	BIT	LABEL	DEFAULT	DESCRIPTION
R1552 (0610h) DAC1 Left Volume	9	DAC1L_MUTE	1	DAC1L Soft Mute Control 0 = DAC Un-mute 1 = DAC Mute
	8	DAC1_VU	0	DAC1L and DAC1R Volume Update Writing a 1 to this bit will cause the DAC1L and DAC1R volume to be updated simultaneously

REGISTER ADDRESS	BIT	LABEL	DEFAULT	DESCRIPTION
	7:0	DAC1L_VOL [7:0]	1100_0000	DAC1L Digital Volume 00h = MUTE 01h = -71.625dB ... (0.375dB steps) C0h = 0dB ... (0.375dB steps) E0h = 12dB FFh = 12dB

Register 0610h DAC1 Left Volume

REGISTER ADDRESS	BIT	LABEL	DEFAULT	DESCRIPTION
R1553 (0611h) DAC1 Right Volume	9	DAC1R_MUTE	1	DAC1R Soft Mute Control 0 = DAC Un-mute 1 = DAC Mute
	8	DAC1_VU	0	DAC1L and DAC1R Volume Update Writing a 1 to this bit will cause the DAC1L and DAC1R volume to be updated simultaneously
	7:0	DAC1R_VOL [7:0]	1100_0000	DAC1R Digital Volume 00h = MUTE 01h = -71.625dB ... (0.375dB steps) C0h = 0dB ... (0.375dB steps) E0h = 12dB FFh = 12dB

Register 0611h DAC1 Right Volume

REGISTER ADDRESS	BIT	LABEL	DEFAULT	DESCRIPTION
R1554 (0612h) AIF2TX Left Volume	9	AIF2TXL_MUTE	1	AIF2 Tx (Left) Soft Mute Control 0 = Un-mute 1 = Mute
	8	AIF2TX_VU	0	AIF2 Tx (Left) and AIF2 Tx (Right) Volume Update Writing a 1 to this bit will cause the AIF2TXL and AIF2TXR volume to be updated simultaneously
	7:0	AIF2TXL_VOL [7:0]	1100_0000	AIF2 Tx (Left) Volume Digital Volume 00h = MUTE 01h = -71.625dB ... (0.375dB steps) C0h = 0dB ... (0.375dB steps) E0h = 12dB FFh = 12dB

Register 0612h AIF2TX Left Volume

REGISTER ADDRESS	BIT	LABEL	DEFAULT	DESCRIPTION
R1555 (0613h) AIF2TX Right Volume	9	AIF2TXR_MUTE	1	AIF2 Tx (Right) Soft Mute Control 0 = DAC Un-mute 1 = DAC Mute
	8	AIF2TX_VU	0	AIF2 Tx (Left) and AIF2 Tx (Right) Volume Update Writing a 1 to this bit will cause the AIF2TXL and AIF2TXR volume to be updated simultaneously
	7:0	AIF2TXR_VOL [7:0]	1100_0000	AIF2 Tx (Right) Digital Volume 00h = MUTE 01h = -71.625dB ... (0.375dB steps) C0h = 0dB ... (0.375dB steps) E0h = 12dB FFh = 12dB

Register 0613h AIF2TX Right Volume

REGISTER ADDRESS	BIT	LABEL	DEFAULT	DESCRIPTION
R1556 (0614h) DAC Softmute	1	DAC_SOFTMUTE MODE	0	DAC/AIF2 Digital Output Mixer Unmute Ramp select 0 = Unmuting the DAC / AIF2 volume will immediately apply the DAC1[L/R]_VOL or AIF2TX[L/R]_VOL settings. 1 = Unmuting the DAC / AIF2 volume will cause a gradual ramp up to the DAC1[L/R]_VOL or AIF2TX[L/R]_VOL settings.
	0	DAC_MUTERATE	0	DAC/AIF2 Digital Output Mixer Soft Mute Ramp Rate 0 = Fast ramp (fs/2, maximum ramp time is 10.7ms at fs=48k) 1 = Slow ramp (fs/32, maximum ramp time is 171ms at fs=48k) (Note: ramp rate scales with sample rate.)

Register 0614h DAC Softmute

REGISTER ADDRESS	BIT	LABEL	DEFAULT	DESCRIPTION
R1568 (0620h) Oversampling	1	ADC_OSR128	1	ADC / Digital Microphone Oversample Rate Select 0 = Low Power 1 = High Performance
	0	DAC_OSR128	0	DAC Oversample Rate Select 0 = Low Power 1 = High Performance

Register 0620h Oversampling

REGISTER ADDRESS	BIT	LABEL	DEFAULT	DESCRIPTION
R1569 (0621h) Sidetone	9:7	ST_HPF_CUT [2:0]	000	Sidetone HPF cut-off frequency (relative to 44.1kHz sample rate) 000 = 2.7kHz 001 = 1.35kHz 010 = 675Hz 011 = 370Hz 100 = 180Hz 101 = 90Hz 110 = 45Hz 111 = Reserved Note - the cut-off frequencies scale with the Digital Mixing (SYSCLK) clocking rate. The quoted figures apply to 44.1kHz sample rate.
	6	ST_HPF	0	Digital Sidetone HPF Select 0 = Disabled 1 = Enabled

Register 0621h Sidetone

REGISTER ADDRESS	BIT	LABEL	DEFAULT	DESCRIPTION
R1792 (0700h) GPIO 1	15	GP1_DIR	1	GPIO1 Pin Direction 0 = Output 1 = Input
	14	GP1_PU	0	GPIO1 Pull-Up Enable 0 = Disabled 1 = Enabled
	13	GP1_PD	0	GPIO1 Pull-Down Enable 0 = Disabled 1 = Enabled
	10	GP1_POL	0	GPIO1 Polarity Select 0 = Non-inverted (Active High) 1 = Inverted (Active Low)
	9	GP1_OP_CFG	0	GPIO1 Output Configuration 0 = CMOS 1 = Open Drain
	8	GP1_DB	1	GPIO1 Input De-bounce 0 = Disabled 1 = Enabled
	6	GP1_LVL	0	GPIO1 level. Write to this bit to set a GPIO output. Read from this bit to read GPIO input level. For output functions only, when GP1_POL is set, the register contains the opposite logic level to the external pin.
	4:0	GP1_FN [4:0]	0_0000	GPIO1 Pin Function 00h = ADCLRCLK1 01h = GPIO 02h = Reserved 03h = IRQ 04h = Temperature (Shutdown) status 05h = MICDET status 06h = Reserved 07h = Reserved 08h = Reserved 09h = FLL1 Lock

REGISTER ADDRESS	BIT	LABEL	DEFAULT	DESCRIPTION
				0Ah = FLL2 Lock 0Bh = SRC1 Lock 0Ch = SRC2 Lock 0Dh = AIF1 DRC Signal Detect 0Eh = Reserved 0Fh = AIF2 DRC Signal Detect 10h = Reserved 11h = FIFO Error 12h = OPCLK Clock output 13h = Temperature (Warning) status 14h = DC Servo Done 15h = FLL1 Clock output 16h = FLL2 Clock output 17h to 1Fh = Reserved

Register 0700h GPIO 1

REGISTER ADDRESS	BIT	LABEL	DEFAULT	DESCRIPTION
R1793 (0701h) Pull Control (MCLK2)	15	Reserved	1	Reserved - do not change
	14	MCLK2_PU	0	MCLK2 Pull-up enable 0 = Disabled 1 = Enabled
	13	MCLK2_PD	1	MCLK2 Pull-down enable 0 = Disabled 1 = Enabled
	8	Reserved	1	Reserved - do not change
	0	Reserved	1	Reserved - do not change

Register 0701h Pull Control (MCLK2)

REGISTER ADDRESS	BIT	LABEL	DEFAULT	DESCRIPTION
R1794 (0702h) Pull Control (BCLK2)	15	Reserved	1	Reserved - do not change
	14	BCLK2_PU	0	BCLK2 Pull-up enable 0 = Disabled 1 = Enabled
	13	BCLK2_PD	1	BCLK2 Pull-down enable 0 = Disabled 1 = Enabled
	8	Reserved	1	Reserved - do not change
	0	Reserved	1	Reserved - do not change

Register 0702h Pull Control (BCLK2)

REGISTER ADDRESS	BIT	LABEL	DEFAULT	DESCRIPTION
R1795 (0703h) Pull Control (DACLRCLK2)	15	Reserved	1	Reserved - do not change
	14	DACLRCLK2_PU	0	DACLRCLK2 Pull-up enable 0 = Disabled 1 = Enabled
	13	DACLRCLK2_PD	1	DACLRCLK2 Pull-down enable 0 = Disabled 1 = Enabled
	8	Reserved	1	Reserved - do not change
	0	Reserved	1	Reserved - do not change

Register 0703h Pull Control (DACLRCLK2)

REGISTER ADDRESS	BIT	LABEL	DEFAULT	DESCRIPTION
R1796 (0704h) Pull Control (DACDAT2)	15	Reserved	1	Reserved - do not change
	14	DACDAT2_PU	0	DACDAT2 Pull-up enable 0 = Disabled 1 = Enabled
	13	DACDAT2_PD	1	DACDAT2 Pull-down enable 0 = Disabled 1 = Enabled
	8	Reserved	1	Reserved - do not change
	0	Reserved	1	Reserved - do not change

Register 0704h Pull Control (DACDAT2)

REGISTER ADDRESS	BIT	LABEL	DEFAULT	DESCRIPTION
R1797 (0705h) JACKDET Ctrl	15		1	Reserved - do not change
	13		1	Reserved - do not change
	8	JACKDET_DB	1	JACKDET input de-bounce 0 = Disabled 1 = Enabled
	6	JACKDET_LVL	0	JACKDET input status 0 = Jack not detected 1 = Jack is detected
	0		1	Reserved - do not change

Register 0705hJACKDET Ctrl

REGISTER ADDRESS	BIT	LABEL	DEFAULT	DESCRIPTION
R1799 (0707h) GPIO 8	15	GP8_DIR	1	GPIO8 Pin Direction 0 = Output 1 = Input
	14	GP8_PU	0	GPIO8 Pull-Up Enable 0 = Disabled 1 = Enabled

REGISTER ADDRESS	BIT	LABEL	DEFAULT	DESCRIPTION
	13	GP8_PD	1	GPIO8 Pull-Down Enable 0 = Disabled 1 = Enabled
	10	GP8_POL	0	GPIO8 Polarity Select 0 = Non-inverted (Active High) 1 = Inverted (Active Low)
	9	GP8_OP_CFG	0	GPIO8 Output Configuration 0 = CMOS 1 = Open Drain
	8	GP8_DB	1	GPIO8 Input De-bounce 0 = Disabled 1 = Enabled
	6	GP8_LVL	0	GPIO8 level. Write to this bit to set a GPIO output. Read from this bit to read GPIO input level. For output functions only, when GP8_POL is set, the register contains the opposite logic level to the external pin.
	4:0	GP8_FN [4:0]	0_0001	GPIO8 Pin Function 00h = DACDAT3 01h = GPIO 02h = Reserved 03h = IRQ 04h = Temperature (Shutdown) status 05h = MICDET status 06h = Reserved 07h = Reserved 08h = Reserved 09h = FLL1 Lock 0Ah = FLL2 Lock 0Bh = SRC1 Lock 0Ch = SRC2 Lock 0Dh = AIF1 DRC Signal Detect 0Eh = Reserved 0Fh = AIF2 DRC Signal Detect 10h = Reserved 11h = FIFO Error 12h = OPCLK Clock output 13h = Temperature (Warning) status 14h = DC Servo Done 15h = FLL1 Clock output 16h = FLL2 Clock output 17h to 1Fh = Reserved

Register 0707h GPIO 8

REGISTER ADDRESS	BIT	LABEL	DEFAULT	DESCRIPTION
R1800 (0708h) GPIO 9	15	GP9_DIR	1	GPIO9 Pin Direction 0 = Output 1 = Input
	14	GP9_PU	0	GPIO9 Pull-Up Enable 0 = Disabled 1 = Enabled
	13	GP9_PD	1	GPIO9 Pull-Down Enable 0 = Disabled 1 = Enabled
	10	GP9_POL	0	GPIO9 Polarity Select 0 = Non-inverted (Active High) 1 = Inverted (Active Low)
	9	GP9_OP_CFG	0	GPIO9 Output Configuration 0 = CMOS 1 = Open Drain
	8	GP9_DB	1	GPIO9 Input De-bounce 0 = Disabled 1 = Enabled
	6	GP9_LVL	0	GPIO9 level. Write to this bit to set a GPIO output. Read from this bit to read GPIO input level. For output functions only, when GP9_POL is set, the register contains the opposite logic level to the external pin.
	4:0	GP9_FN [4:0]	0_0001	GPIO9 Pin Function 00h = ADCDAT3 01h = GPIO 02h = Reserved 03h = IRQ 04h = Temperature (Shutdown) status 05h = MICDET status 06h = Reserved 07h = Reserved 08h = Reserved 09h = FLL1 Lock 0Ah = FLL2 Lock 0Bh = SRC1 Lock 0Ch = SRC2 Lock 0Dh = AIF1 DRC Signal Detect 0Eh = Reserved 0Fh = AIF2 DRC Signal Detect 10h = Reserved 11h = FIFO Error 12h = OPCLK Clock output 13h = Temperature (Warning) status 14h = DC Servo Done 15h = FLL1 Clock output 16h = FLL2 Clock output 17h to 1Fh = Reserved

Register 0708h GPIO 9



REGISTER ADDRESS	BIT	LABEL	DEFAULT	DESCRIPTION
R1801 (0709h) GPIO 10	15	GP10_DIR	1	GPIO10 Pin Direction 0 = Output 1 = Input
	14	GP10_PU	0	GPIO10 Pull-Up Enable 0 = Disabled 1 = Enabled
	13	GP10_PD	1	GPIO10 Pull-Down Enable 0 = Disabled 1 = Enabled
	10	GP10_POL	0	GPIO10 Polarity Select 0 = Non-inverted (Active High) 1 = Inverted (Active Low)
	9	GP10_OP_CFG	0	GPIO10 Output Configuration 0 = CMOS 1 = Open Drain
	8	GP10_DB	1	GPIO10 Input De-bounce 0 = Disabled 1 = Enabled
	6	GP10_LVL	0	GPIO10 level. Write to this bit to set a GPIO output. Read from this bit to read GPIO input level. For output functions only, when GP10_POL is set, the register contains the opposite logic level to the external pin.
	4:0	GP10_FN [4:0]	0_0001	GPIO10 Pin Function 00h = LRCLK3 01h = GPIO 02h = Reserved 03h = IRQ 04h = Temperature (Shutdown) status 05h = MICDET status 06h = Reserved 07h = Reserved 08h = Reserved 09h = FLL1 Lock 0Ah = FLL2 Lock 0Bh = SRC1 Lock 0Ch = SRC2 Lock 0Dh = AIF1 DRC Signal Detect 0Eh = Reserved 0Fh = AIF2 DRC Signal Detect 10h = Reserved 11h = FIFO Error 12h = OPCLK Clock output 13h = Temperature (Warning) status 14h = DC Servo Done 15h = FLL1 Clock output 16h = FLL2 Clock output 17h to 1Fh = Reserved

Register 0709h GPIO 10

REGISTER ADDRESS	BIT	LABEL	DEFAULT	DESCRIPTION
R1802 (070Ah) GPIO 11	15	GP11_DIR	1	GPIO11 Pin Direction 0 = Output 1 = Input
	14	GP11_PU	0	GPIO11 Pull-Up Enable 0 = Disabled 1 = Enabled
	13	GP11_PD	1	GPIO11 Pull-Down Enable 0 = Disabled 1 = Enabled
	10	GP11_POL	0	GPIO11 Polarity Select 0 = Non-inverted (Active High) 1 = Inverted (Active Low)
	9	GP11_OP_CFG	0	GPIO11 Output Configuration 0 = CMOS 1 = Open Drain
	8	GP11_DB	1	GPIO11 Input De-bounce 0 = Disabled 1 = Enabled
	6	GP11_LVL	0	GPIO11 level. Write to this bit to set a GPIO output. Read from this bit to read GPIO input level. For output functions only, when GP11_POL is set, the register contains the opposite logic level to the external pin.
	4:0	GP11_FN [4:0]	0_0001	GPIO11 Pin Function 00h = BCLK3 01h = GPIO 02h = Reserved 03h = IRQ 04h = Temperature (Shutdown) status 05h = MICDET status 06h = Reserved 07h = Reserved 08h = Reserved 09h = FLL1 Lock 0Ah = FLL2 Lock 0Bh = SRC1 Lock 0Ch = SRC2 Lock 0Dh = AIF1 DRC Signal Detect 0Eh = Reserved 0Fh = AIF2 DRC Signal Detect 10h = Reserved 11h = FIFO Error 12h = OPCLK Clock output 13h = Temperature (Warning) status 14h = DC Servo Done 15h = FLL1 Clock output 16h = FLL2 Clock output 17h to 1Fh = Reserved

Register 070Ah GPIO 11

REGISTER ADDRESS	BIT	LABEL	DEFAULT	DESCRIPTION
R1824 (0720h) Pull Control (1)	9	DMICDAT1_PU	0	DMICDAT Pull-Up enable 0 = Disabled 1 = Enabled
	8	DMICDAT1_PD	0	DMICDAT Pull-Down enable 0 = Disabled 1 = Enabled
	7	MCLK1_PU	0	MCLK1 Pull-up enable 0 = Disabled 1 = Enabled
	6	MCLK1_PD	0	MCLK1 Pull-down enable 0 = Disabled 1 = Enabled
	5	DACDAT1_PU	0	DACDAT1 Pull-up enable 0 = Disabled 1 = Enabled
	4	DACDAT1_PD	0	DACDAT1 Pull-down enable 0 = Disabled 1 = Enabled
	3	DACLCLK1_PU	0	LRCLK1 Pull-up enable 0 = Disabled 1 = Enabled
	2	DACLCLK1_PD	0	LRCLK1 Pull-down enable 0 = Disabled 1 = Enabled
	1	BCLK1_PU	0	BCLK1 Pull-up enable 0 = Disabled 1 = Enabled
	0	BCLK1_PD	0	BCLK1 Pull-down enable 0 = Disabled 1 = Enabled

Register 0720h Pull Control (1)

REGISTER ADDRESS	BIT	LABEL	DEFAULT	DESCRIPTION
R1825 (0721h) Pull Control (2)	8	ADDR_PD	1	ADDR Pull-down enable 0 = Disabled 1 = Enabled
	6	LDO2ENA_PD	1	LDO2ENA Pull-down enable 0 = Disabled 1 = Enabled
	4	LDO1ENA_PD	1	LDO1ENA Pull-down enable 0 = Disabled 1 = Enabled
	2	Reserved	1	Reserved - do not change
	1	SPKMODE_PU	1	SPKMODE Pull-up enable 0 = Disabled 1 = Enabled

Register 0721h Pull Control (2)

REGISTER ADDRESS	BIT	LABEL	DEFAULT	DESCRIPTION
R1840 (0730h) Interrupt Status 1	10	GP11_EINT	0	GPIO11 Interrupt (Rising and falling edge triggered) Note: Cleared when a '1' is written.
	9	GP10_EINT	0	GPIO10 Interrupt (Rising and falling edge triggered) Note: Cleared when a '1' is written.
	8	GP9_EINT	0	GPIO9 Interrupt (Rising and falling edge triggered) Note: Cleared when a '1' is written.
	7	GP8_EINT	0	GPIO8 Interrupt (Rising and falling edge triggered) Note: Cleared when a '1' is written.
	5	JACKDET_EINT	0	Jack Detect Interrupt (Rising and falling edge triggered) Note: Cleared when a '1' is written.
	0	GP1_EINT	0	GPIO1 Interrupt (Rising and falling edge triggered) Note: Cleared when a '1' is written.

Register 0730h Interrupt Status 1

REGISTER ADDRESS	BIT	LABEL	DEFAULT	DESCRIPTION
R1841 (0731h) Interrupt Status 2	15	TEMP_WARN_EINT	0	Temperature Warning Interrupt (Rising and falling edge triggered) Note: Cleared when a '1' is written.
	14	DCS_DONE_EINT	0	DC Servo Interrupt (Rising edge triggered) Note: Cleared when a '1' is written.
	12	FIFOS_ERR_EINT	0	Digital Core FIFO Error Interrupt (Rising edge triggered) Note: Cleared when a '1' is written.
	11	AIF2DRC_SIG_DET_EINT	0	AIF2 DRC Activity Detect Interrupt (Rising edge triggered) Note: Cleared when a '1' is written.
	9	AIF1DRC1_SIG_DET_EINT	0	AIF1 DRC Activity Detect Interrupt (Rising edge triggered) Note: Cleared when a '1' is written.
	8	SRC2_LOCK_EINT	0	SRC2 Lock Interrupt (Rising and falling edge triggered) Note: Cleared when a '1' is written.
	7	SRC1_LOCK_EINT	0	SRC1 Lock Interrupt (Rising and falling edge triggered) Note: Cleared when a '1' is written.
	6	FLL2_LOCK_EINT	0	FLL2 Lock Interrupt (Rising and falling edge triggered) Note: Cleared when a '1' is written.
	5	FLL1_LOCK_EINT	0	FLL1 Lock Interrupt (Rising and falling edge triggered) Note: Cleared when a '1' is written.

REGISTER ADDRESS	BIT	LABEL	DEFAULT	DESCRIPTION
	1	MICD_EINT	0	Microphone Detection Interrupt (Rising and falling edge triggered) Note: Cleared when a '1' is written.
	0	TEMP_SHUT_EINT	0	Temperature Shutdown Interrupt (Rising and falling edge triggered) Note: Cleared when a '1' is written.

Register 0731h Interrupt Status 2

REGISTER ADDRESS	BIT	LABEL	DEFAULT	DESCRIPTION
R1842 (0732h) Interrupt Raw Status 2	15	TEMP_WARN_STS	0	Temperature Warning status 0 = Temperature is below warning level 1 = Temperature is above warning level
	14	DCS_DONE_STS	0	DC Servo status 0 = DC Servo not complete 1 = DC Servo complete
	12	FIFOS_ERR_STS	0	Digital Core FIFO Error status 0 = Normal operation 1 = FIFO Error
	11	AIF2DRC_SIG_DET_STS	0	AIF2 DRC Signal Detect status 0 = Signal threshold not exceeded 1 = Signal threshold not exceeded
	9	AIF1DRC1_SIG_DET_STS	0	AIF1 DRC Signal Detect status 0 = Signal threshold not exceeded 1 = Signal threshold not exceeded
	8	SRC2_LOCK_STS	0	SRC2 Lock status 0 = Not locked 1 = Locked
	7	SRC1_LOCK_STS	0	SRC1 Lock status 0 = Not locked 1 = Locked
	6	FLL2_LOCK_STS	0	FLL2 Lock status 0 = Not locked 1 = Locked
	5	FLL1_LOCK_STS	0	FLL1 Lock status 0 = Not locked 1 = Locked
	0	TEMP_SHUT_STS	0	Temperature Shutdown status 0 = Temperature is below shutdown level 1 = Temperature is above shutdown level

Register 0732h Interrupt Raw Status 2

REGISTER ADDRESS	BIT	LABEL	DEFAULT	DESCRIPTION
R1848 (0738h) Interrupt Status 1 Mask	10	IM_GP11_EINT	1	GPIO11 Interrupt mask. 0 = Do not mask interrupt. 1 = Mask interrupt.
	9	IM_GP10_EINT	1	GPIO10 Interrupt mask. 0 = Do not mask interrupt.

REGISTER ADDRESS	BIT	LABEL	DEFAULT	DESCRIPTION
				1 = Mask interrupt.
	8	IM_GP9_EINT	1	GPIO9Interrupt mask. 0 = Do not mask interrupt. 1 = Mask interrupt.
	7	IM_GP8_EINT	1	GPIO8Interrupt mask. 0 = Do not mask interrupt. 1 = Mask interrupt.
	6	Reserved	1	Reserved - do not change
	5	IM_JACKDET_EINT	1	Jack DetectInterrupt mask. 0 = Do not mask interrupt. 1 = Mask interrupt.
	4	Reserved	1	Reserved - do not change
	3	Reserved	1	Reserved - do not change
	2	Reserved	1	Reserved - do not change
	1	Reserved	1	Reserved - do not change
	0	IM_GP1_EINT	1	GPIO1Interrupt mask. 0 = Do not mask interrupt. 1 = Mask interrupt.

Register 0738h Interrupt Status 1 Mask

REGISTER ADDRESS	BIT	LABEL	DEFAULT	DESCRIPTION
R1849 (0739h) Interrupt Status 2 Mask	15	IM_TEMP_WARN_EINT	1	Temperature Warning Interrupt mask. 0 = Do not mask interrupt. 1 = Mask interrupt.
	14	IM_DCS_DONE_EINT	1	DC Servo Interrupt mask. 0 = Do not mask interrupt. 1 = Mask interrupt.
	12	IM_FIFOS_ERR_EINT	1	Digital Core FIFO Error Interrupt mask. 0 = Do not mask interrupt. 1 = Mask interrupt.
	11	IM_AIF2DRC_SIG_DET_EINT	1	AIF2 DRC Activity Detect Interrupt mask. 0 = Do not mask interrupt. 1 = Mask interrupt.
	9	IM_AIF1DRC1_SIG_DET_EINT	1	AIF1 DRC Activity Detect Interrupt mask. 0 = Do not mask interrupt. 1 = Mask interrupt.
	8	IM_SRC2_LOCK_EINT	1	SRC2 Lock Interrupt mask. 0 = Do not mask interrupt. 1 = Mask interrupt.
	7	IM_SRC1_LOCK_EINT	1	SRC1 Lock Interrupt mask. 0 = Do not mask interrupt. 1 = Mask interrupt.
	6	IM_FLL2_LOCK_EINT	1	FLL2 Lock Interrupt mask. 0 = Do not mask interrupt. 1 = Mask interrupt.
	5	IM_FLL1_LOCK_EINT	1	FLL1 Lock Interrupt mask. 0 = Do not mask interrupt. 1 = Mask interrupt.

REGISTER ADDRESS	BIT	LABEL	DEFAULT	DESCRIPTION
	1	IM_MICD_EINT	1	Microphone Detection Interrupt mask. 0 = Do not mask interrupt. 1 = Mask interrupt.
	0	IM_TEMP_SHUT_EINT	1	Temperature Shutdown Interrupt mask. 0 = Do not mask interrupt. 1 = Mask interrupt.

**Register 0739h** Interrupt Status 2 Mask

REGISTER ADDRESS	BIT	LABEL	DEFAULT	DESCRIPTION
R1856 (0740h) Interrupt Control	0	IM_IRQ	0	IRQ Output Interrupt mask. 0 = Do not mask interrupt. 1 = Mask interrupt.

**Register 0740h** Interrupt Control

REGISTER ADDRESS	BIT	LABEL	DEFAULT	DESCRIPTION
R1864 (0748h) IRQ Debounce	5	TEMP_WARN_D B	1	Thermal Warning de-bounce 0 = Disabled 1 = Enabled
	4	Reserved	1	Reserved - do not change
	3	Reserved	1	Reserved - do not change
	2	Reserved	1	Reserved - do not change
	1	Reserved	1	Reserved - do not change
	0	TEMP_SHUT_DB	1	Thermal shutdown de-bounce 0 = Disabled 1 = Enabled

**Register 0748h** IRQ Debounce

## APPLICATIONS INFORMATION

## RECOMMENDED EXTERNAL COMPONENTS

## AUDIO INPUT PATHS

The WM1811A provides 8 analogue audio inputs. Each of these inputs is referenced to the internal DC reference, VMID. A DC blocking capacitor is required for each input pin used in the target application. The choice of capacitor is determined by the filter that is formed between that capacitor and the input impedance of the input pin. The circuit is illustrated in Figure 82.

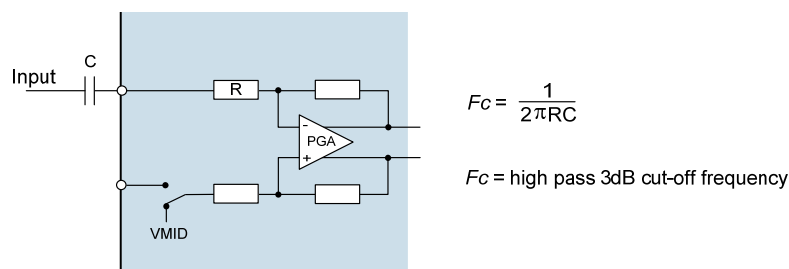

Figure 82 Audio Input Path DC Blocking Capacitor

If the input impedance is known, and the cut-off frequency is known, then the minimum capacitor value may be derived easily. However, it can be seen from the representation in Figure 82 that the input impedance is not fixed in all applications but can vary with gain and boost amplifier settings.

The PGA input resistance for every gain setting is detailed in Table 135.

IN1L_VOL[4:0], IN2L_VOL[4:0], IN1R_VOL[4:0], IN2R_VOL[4:0]	VOLUME (dB)	INPUT RESISTANCE (kΩ)	
		SINGLE-ENDED MODE	DIFFERENTIAL MODE
00000	-16.5	58	52.5
00001	-15.0	56.9	50.6
00010	-13.5	55.6	48.6
00011	-12.0	54.1	46.4
00100	-10.5	52.5	44.1
00101	-9.0	50.7	41.5
00110	-7.5	48.6	38.9
00111	-6.0	46.5	36.2
01000	-4.5	44.1	33.4
01001	-3.0	41.6	30.6
01010	-1.5	38.9	27.8
01011	0	36.2	25.1
01100	+1.5	33.4	22.5
01101	+3.0	30.6	20.0
01110	+4.5	27.8	17.7
01111	+6.0	25.1	15.6
10000	+7.5	22.5	13.6
10001	+9.0	20.1	11.9
10010	+10.5	17.8	10.3
10011	+12.0	15.6	8.9
10100	+13.5	13.7	7.6



IN1L_VOL[4:0], IN2L_VOL[4:0], IN1R_VOL[4:0], IN2R_VOL[4:0]	VOLUME (dB)	INPUT RESISTANCE (k $\Omega$ )	
		SINGLE-ENDED MODE	DIFFERENTIAL MODE
10101	+15.0	11.9	6.5
10110	+16.5	10.3	5.6
10111	+18.0	8.9	4.8
11000	+19.5	7.7	4.1
11001	+21.0	6.6	3.5
11010	+22.5	5.6	2.9
11011	+24.0	4.8	2.5
11100	+25.5	4.1	2.1
11101	+27.0	3.5	1.8
11110	+28.5	2.9	1.5
11111	+30.0	2.5	1.3

Table 135 PGA Input Pin Resistance

The appropriate input capacitor may be selected using the PGA input resistance data provided in Table 135, depending on the required PGA gain setting(s).

The choice of capacitor for a 20Hz cut-off frequency is shown in Table 136 for a selection of typical input impedance conditions.

INPUT IMPEDANCE	MINIMUM CAPACITANCE FOR 20HZ PASS BAND
2k $\Omega$	4 $\mu$ F
15k $\Omega$	0.5 $\mu$ F
30k $\Omega$	0.27 $\mu$ F
60k $\Omega$	0.13 $\mu$ F

Table 136 Audio InputDC Blocking Capacitors

Using the figures in Table 136, it follows that a 1 $\mu$ F capacitance for all input connections will give good results in most cases. Tantalum electrolytic capacitors are particularly suitable as they offer high stability in a small package size.

Ceramic equivalents are a cost effective alternative to the superior tantalum packages, but care must be taken to ensure the desired capacitance is maintained at the AVDD1 operating voltage. Also, ceramic capacitors may show microphonic effects, where vibrations and mechanical conditions give rise to electrical signals. This is particularly problematic for microphone input paths where a large signal gain is required.

A single capacitor is required for a line input or single-ended microphone connection. In the case of a differential microphone connection, a DC blocking capacitor is required on both input pins.

### HEADPHONE OUTPUT PATH

The headphone output on WM1811A is ground referenced and therefore does not require the large, expensive capacitors necessary for VMID reference solutions. The headphone load may be connected directly to the HPOUT1L and HPOUT1R pins, as illustrated in the "Analogue Outputs" section.

**EARPIECE DRIVER OUTPUT PATH**

The earpiece driver on HPOUT2P and HPOUT2N is designed as a 32ohm BTL speaker driver. The outputs are referenced to the internal DC reference VMID, but direct connection to the speaker is possible because of the BTL configuration. There is no requirement for DC blocking capacitors.

**LINE OUTPUT PATHS**

The WM1811A provides four line outputs (LINEOUT1P, LINEOUT1N, LINEOUT2P and LINEOUT2N). Each of these outputs is referenced to the internal DC reference, VMID. In any case where a line output is used in a single-ended configuration (i.e. referenced to AGND), a DC blocking capacitor will be required in order to remove the DC bias. In the case where a pair of line outputs is configured as a BTL differential pair, then the DC blocking capacitor should be omitted.

The choice of capacitor is determined from the filter that is formed between the capacitor and the load impedance – see Figure 83.

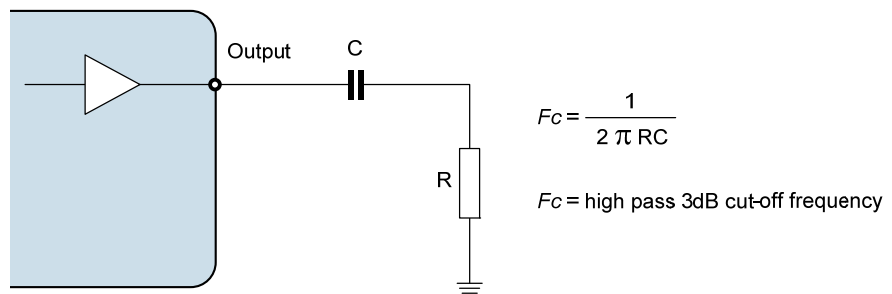

**Figure 83 Line Output Path Components**

LOAD IMPEDANCE	MINIMUM CAPACITANCE FOR 20HZ PASS BAND
10kΩ	0.8 μF
47kΩ	0.17 μF

**Table 137 Line Output Frequency Cut-Off**

Using the figures in Table 137, it follows that that a 1μF capacitance would be a suitable choice for a line load. Tantalum electrolytic capacitors are again particularly suitable but ceramic equivalents are a cost effective alternative. Care must be taken to ensure the desired capacitance is maintained at the appropriate operating voltage.

## POWER SUPPLY DECOUPLING

Electrical coupling exists particularly in digital logic systems where switching in one sub-system causes fluctuations on the power supply. This effect occurs because the inductance of the power supply acts in opposition to the changes in current flow that are caused by the logic switching. The resultant variations (or 'spikes') in the power supply voltage can cause malfunctions and unintentional behavior in other components. A decoupling (or 'bypass') capacitor can be used as an energy storage component which will provide power to the decoupled circuit for the duration of these power supply variations, protecting it from malfunctions that could otherwise arise.

Coupling also occurs in a lower frequency form when ripple is present on the power supply rail caused by changes in the load current or by limitations of the power supply regulation method. In audio components such as the WM1811A, these variations can alter the performance of the signal path, leading to degradation in signal quality. A decoupling (or 'bypass') capacitor can be used to filter these effects, by presenting the ripple voltage with a low impedance path that does not affect the circuit to be decoupled.

These coupling effects are addressed by placing a capacitor between the supply rail and the corresponding ground reference. In the case of systems comprising multiple power supply rails, decoupling should be provided on each rail.

The recommended power supply decoupling capacitors for WM1811A are listed below in Table 138.

POWER SUPPLY	DECOUPLING CAPACITOR
LDO1VDD, DBVDD1, DBVDD2, DBVDD3, AVDD2	0.1 $\mu$ F ceramic(see Note)
SPKVDD1, SPKVDD2	4.7 $\mu$ F ceramic
AVDD1	4.7 $\mu$ F ceramic
DCVDD	1.0 $\mu$ F ceramic
CPVDD	4.7 $\mu$ F ceramic
VMIDC	4.7 $\mu$ F ceramic
VREFC	1.0 $\mu$ F ceramic

**Table 138 Power Supply Decoupling Capacitors**

Note: 0.1 $\mu$ F is required with 4.7 $\mu$ F a guide to the total required power rail capacitance, including that at the regulator output.

All decoupling capacitors should be placed as close as possible to the WM1811A device. The connection between AGND, the AVDD1 decoupling capacitor and the main system ground should be made at a single point as close as possible to the AGND ball of the WM1811A.

The VMID capacitor is not, technically, a decoupling capacitor. However, it does serve a similar purpose in filtering noise on the VMID reference. The connection between AGND, the VMID decoupling capacitor and the main system ground should be made at a single point as close as possible to the AGND ball of the WM1811A.

Due to the wide tolerance of many types of ceramic capacitors, care must be taken to ensure that the selected components provide the required capacitance across the required temperature and voltage ranges in the intended application. For most applications, the use of ceramic capacitors with capacitor dielectric X5R is recommended.

### CHARGE PUMP COMPONENTS

A fly-back capacitor is required between the CPCA and CPCB pins. The required capacitance is 2.2 $\mu$ F at 2V.

A decoupling capacitor is required on CPVOUTP and CPVOUTN; the recommended value is 2.2 $\mu$ F at 2V.

The positioning of the Charge Pump capacitors is important, particularly the fly-back capacitor. These capacitors should be placed as close as possible to the WM1811A.

Due to the wide tolerance of many types of ceramic capacitors, care must be taken to ensure that the selected components provide the required capacitance across the required temperature and voltage ranges in the intended application. For most applications, the use of ceramic capacitors with capacitor dielectric X5R is recommended.

### MICROPHONE BIAS CIRCUIT

The WM1811A is designed to interface easily with up to four analogue microphones. These may be connected in single-ended or differential configurations, as illustrated in Figure 84. The single-ended method allows greater capability for the connection of multiple audio sources simultaneously, whilst the differential method provides better performance due to its rejection of common-mode noise.

In either configuration, the analogue microphone requires a bias current (electret condenser microphones) or voltage supply (silicon microphones), which can be provided by MICBIAS1 or MICBIAS2.

A current-limiting resistor is required when using an electret condenser microphone (ECM). The resistance should be chosen according to the minimum operating impedance of the microphone and MICBIAS voltage so that the maximum bias current of the WM1811A is not exceeded. Wolfson recommends a 2.2k $\Omega$  current limiting resistor as it provides compatibility with a wide range of microphone models.

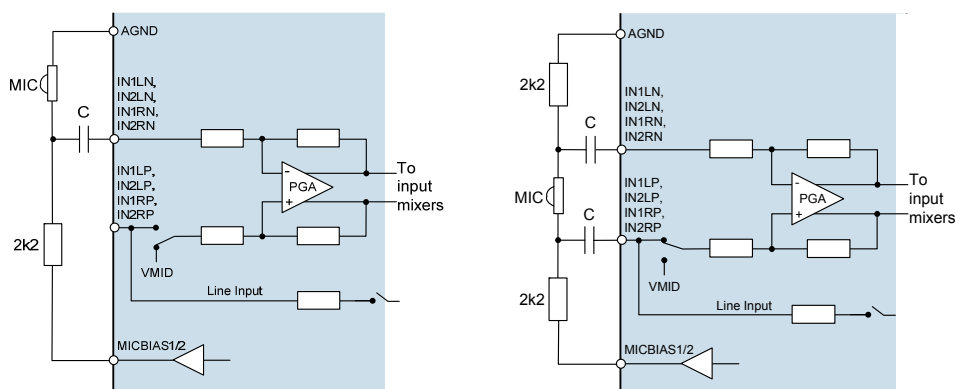

**Figure 84 Single-Ended and Differential Analogue Microphone Connections**

The WM1811A also supports up to two digital microphone inputs. The MICBIAS1 generator is suitable for use as a low noise supply for digital microphones, as shown in Figure 85.

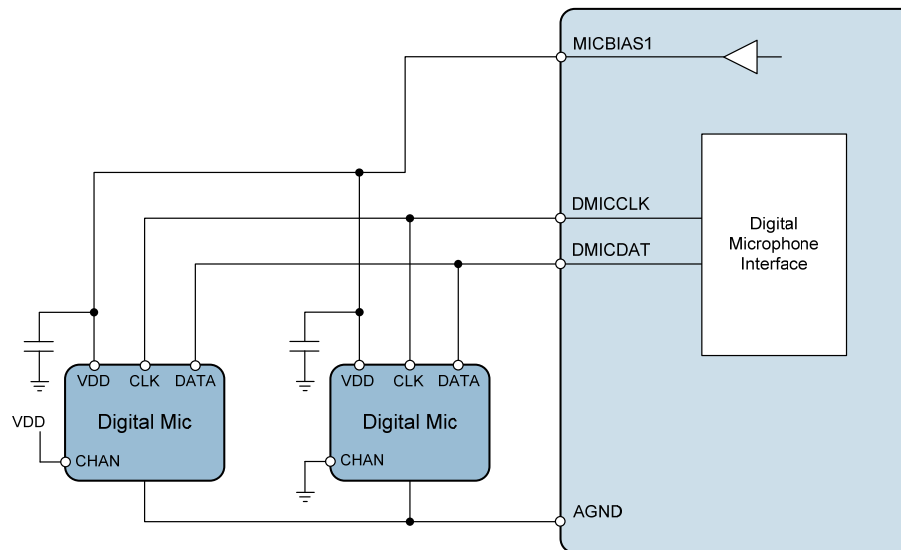

**Figure 85 Digital Microphone Connection**

The MICBIAS generators can each operate as a voltage regulator or in bypass mode. See “Analogue Input Signal Path” for details of the MICBIAS generators.

In Regulator mode, the MICBIAS regulators are designed to operate without external decoupling capacitors. It is important that parasitic capacitances on the MICBIAS1 or MICBIAS2 pins do not exceed the specified limit in Regulator mode (see “Electrical Characteristics”).

If the capacitive load on MICBIAS1 or MICBIAS2 exceeds the specified limit (eg. due to a decoupling capacitor or long PCB trace), then the respective generator must be configured in Bypass mode.

The maximum output current is noted in the “Electrical Characteristics”. This limit must be observed on each MICBIAS output, especially if more than one microphone is connected to a single MICBIAS pin. Note that the maximum output current differs between Regulator mode and Bypass mode. The MICBIAS output voltage can be adjusted using register control in Regulator mode.

### EXTERNAL ACCESSORY DETECTION COMPONENTS

The external accessory detection circuit measures jack insertion using the JACKDET pin. The insertion switch status is detected using an internal pull-up resistor circuit on the JACKDET pin.

Microphone detection and key-button press detection is supported using the MICDET pin. This pin should be connected to the MICBIAS2 output, via a  $2.2\text{k}\Omega$  current-limiting resistor, as described in the “Microphone Bias Circuit” section.

A recommended circuit configuration, including headphone output on HPOUT1 and microphone connections, is shown in Figure 86. See “Audio Input Paths” for details of the DC-blocking microphone input capacitor selection.

The recommended external components and connections for microphone / push-button detection are illustrated in Figure 87.

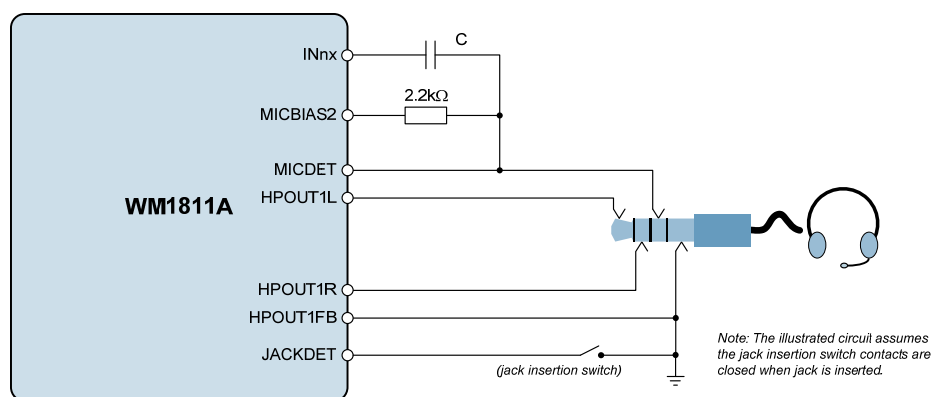

**Figure 86 External Accessory Detection**

The microphone / accessory detection circuit measures the impedance of an external load connected to the MICDET pin.

This function uses the MICBIAS2 output as a reference. Note that the WM1811A will automatically enable MICBIAS2 when required in order to perform the detection function.

The WM1811A can detect the presence of a typical microphone and up to 7 push-buttons, using the components shown in Figure 87. When the microphone detection circuit is enabled, then each of the push-buttons shown will cause a different bit within the MICD\_LVL register to be set.

The microphone detect function is specifically designed to detect a video accessory (typical  $75\Omega$ ) load if required. A measured external impedance of  $75\Omega$  will cause the MICD\_LVL [4] bit to be set.

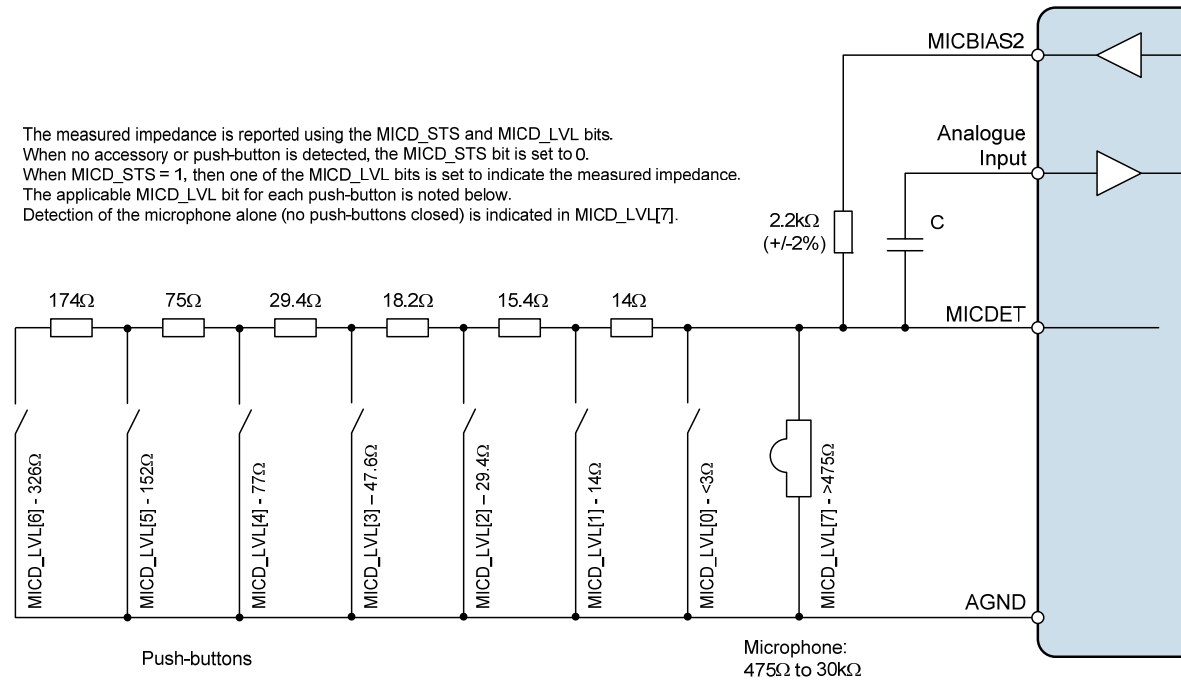
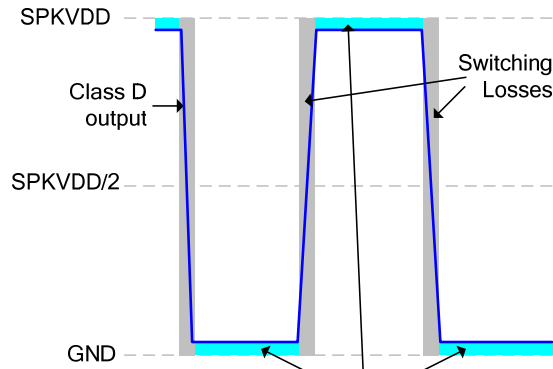

Figure 87 Microphone / Push-Button External Components

**CLASS D SPEAKER CONNECTIONS**

The WM1811A incorporates two Class D speaker drivers, which offer high amplifier efficiency at large signal levels. As the Class D output is a pulse width modulated signal, the choice of speakers and tracking of signals is critical for ensuring good performance and reducing EMI in this mode.

The efficiency of the speaker drivers is affected by the series resistance between the WM1811A and the speaker (e.g. PCB track loss and inductor ESR) as shown in Figure 88. This resistance should be as low as possible to maximise efficiency.



Losses due to resistance between WM1811A and speaker (e.g. inductor ESR)  
This resistance must be minimised in order to maximise efficiency.

**Figure 88 Speaker Connection Losses**

The Class D output requires external filtering in order to recreate the audio signal. This may be implemented using a 2<sup>nd</sup> order LC or 1<sup>st</sup> order RC filter, or else may be achieved by using a loudspeaker whose internal inductance provides the required filter response. An LC or RC filter should be used if the loudspeaker characteristics are unknown or unsuitable, or if the length of the loudspeaker connection is likely to lead to EMI problems.

In applications where it is necessary to provide Class D filter components, a 2<sup>nd</sup> order LC filter is the recommended solution as it provides more attenuation at higher frequencies and minimises power dissipated in the filter when compared to a first order RC filter (lower ESR). This maximises both rejection of unwanted switching frequencies and overall speaker efficiency. A suitable implementation is illustrated in Figure 89.

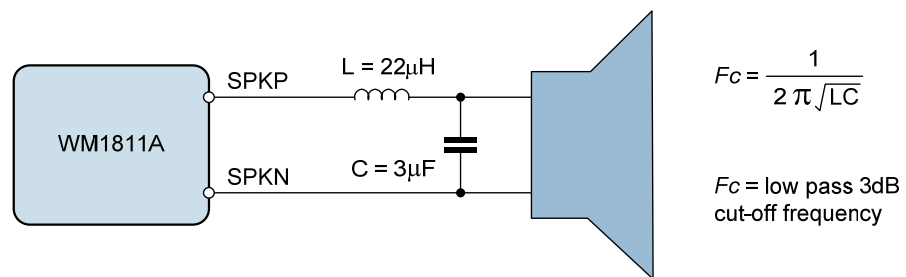

**Figure 89 Class D Output Filter Components**



A simple equivalent circuit of a loudspeaker consists of a serially connected resistor and inductor, as shown in Figure 90. This circuit provides a low pass filter for the speaker output. If the loudspeaker characteristics are suitable, then the loudspeaker itself can be used in place of the filter components described earlier. This is known as 'filterless' operation.

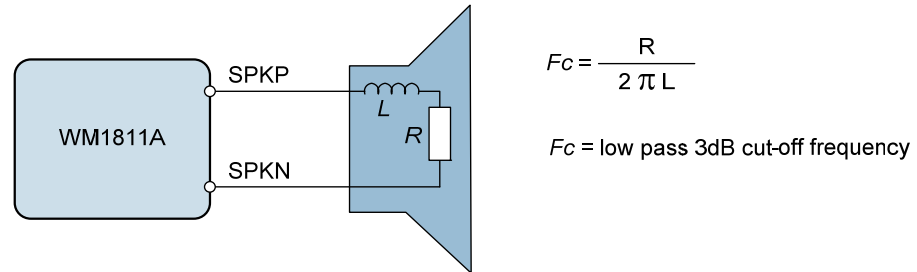

**Figure 90 Speaker Equivalent Circuit for Filterless Operation**

For filterless Class D operation, it is important to ensure that a speaker with suitable inductance is chosen. For example, if we know the speaker impedance is  $8\Omega$  and the desired cut-off frequency is 20kHz, then the optimum speaker inductance may be calculated as:

$$L = \frac{R}{2 \pi F_c} = \frac{8\Omega}{2 \pi * 20\text{kHz}} = 64\mu\text{H}$$

$8\Omega$  loudspeakers typically have an inductance in the range  $20\mu\text{H}$  to  $100\mu\text{H}$ , however, it should be noted that a loudspeaker inductance will not be constant across the relevant frequencies for Class D operation (up to and beyond the Class D switching frequency). Care should be taken to ensure that the cut-off frequency of the loudspeaker's filtering is low enough to suppress the high frequency energy of the Class D switching and, in so doing, to prevent speaker damage. The Class D outputs of the WM1811A operate at much higher frequencies than is recommended for most speakers and it must be ensured that the cut-off frequency is low enough to protect the speaker.

#### RECOMMENDED EXTERNAL COMPONENTS DIAGRAM

Figure 91 provides a summary of recommended external components for WM1811A. Note that this diagram does not include any components that are specific to the end application e.g. it does not include filtering on the speaker outputs (assume filterless Class D operation), RF decoupling, or RF filtering for pins which connect to the external world i.e. headphone or speaker outputs.

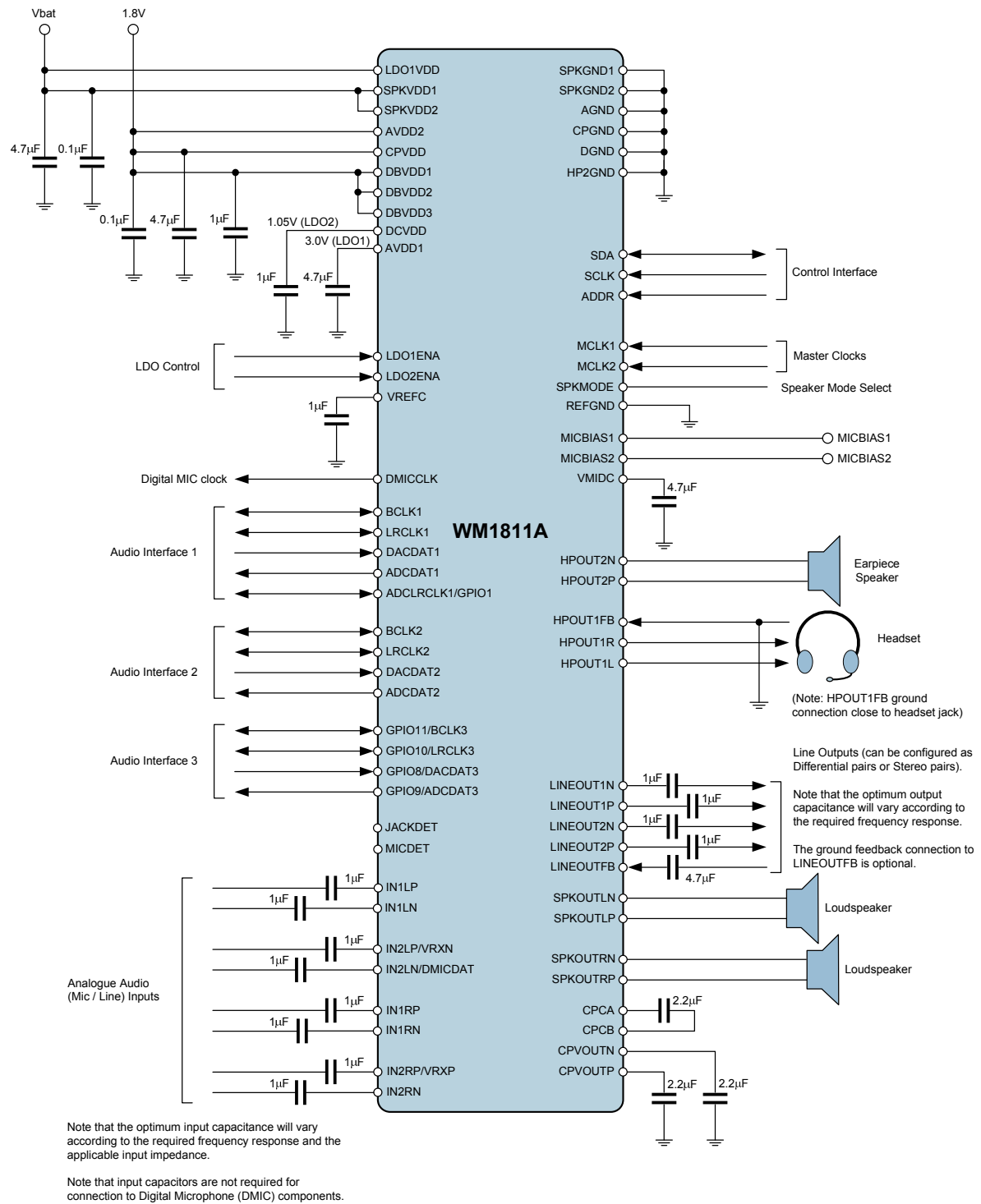

Figure 91 Recommended External Components Diagram

## DIGITAL AUDIO INTERFACE CLOCKING CONFIGURATIONS

The WM1811A provides 3 digital audio interfaces and supports many different clocking configurations. The asynchronous sample rate converter enables more than one digital audio interface to be supported simultaneously, even when there is no synchronisation between these interfaces. In a typical application, this enables audio mixing between a multimedia applications processor and a baseband voice call processor, for example.

The AIF1 and AIF2 audio interfaces can be configured in Master or Slave modes, and can also support defined combinations of mixed sample rates. In all applications, it is important that the system clocking configuration is correctly designed. Incorrect clock configurations will lead to audible clicks arising from dropped or repeated audio samples; this is caused by the inherent tolerances of multiple asynchronous system clocks.

To ensure reliable clocking of the audio interface functions, it is a requirement that, for each audio interface, the external interface clocks (eg. BCLK, LRCLK) are derived from the same clock source as the respective AIF clock (AIFnCLK).

In AIF Master mode, the external BCLK and LRCLK signals are generated by the WM1811A and synchronisation of these signals with AIFnCLK is guaranteed. In this case, clocking of the AIF is derived from the MCLK1 or MCLK2 inputs, either directly or via one of the Frequency Locked Loop (FLL) circuits.

In AIF Slave mode, the external BCLK and LRCLK signals are generated by another device, as inputs to the WM1811A. In this case, it must be ensured that the respective AIF clock is generated from a source that is synchronised to the external BCLK and LRCLK inputs. In a typical Slave mode application, the BCLK input is selected as the clock reference, using the FLL to perform frequency shifting. It is also possible to use the MCLK1 or MCLK2 inputs, but only if the selected clock is synchronised externally to the BCLK and LRCLK inputs.

The valid AIF clocking configurations are listed in Table 139 for AIF Master and AIF Slave modes.

AUDIO INTERFACE MODE	CLOCKING CONFIGURATION
AIF Master Mode	AIFnCLK_SRC selects FLL1 or FLL2 as AIFnCLK source; FLLn_REFCLK_SRC selects MCLK1 or MCLK2 as FLLn source.
	AIFnCLK_SRC selects MCLK1 or MCLK2 as AIFnCLK source.
AIF Slave Mode	AIFnCLK_SRC selects FLL1 or FLL2 as AIFnCLK source; FLLn_REFCLK_SRC selects BCLKn as FLLn source.
	AIFnCLK_SRC selects MCLK1 or MCLK2 as AIFnCLK source, provided MCLK is externally synchronised to the BCLKn input.
	AIFnCLK_SRC selects FLL1 or FLL2 as AIFnCLK source; FLLn_REFCLK_SRC selects MCLK1 or MCLK2 as FLLn source, provided MCLK is externally synchronised to the BCLKn input.

**Table 139 Audio Interface Clocking Configurations**

In each case, the AIFnCLK frequency must be a valid ratio to the LRCLKn frequency; the supported clocking ratios are defined by the AIFnCLK\_RATE register.

The valid AIF clocking configurations are illustrated in Figure 92 to Figure 96 below. Note that, where MCLK1 is illustrated as the clock source, it is equally possible to select MCLK2 as the clock source. Similarly, in cases where FLL1 is illustrated, it is equally possible to select the FLL2.

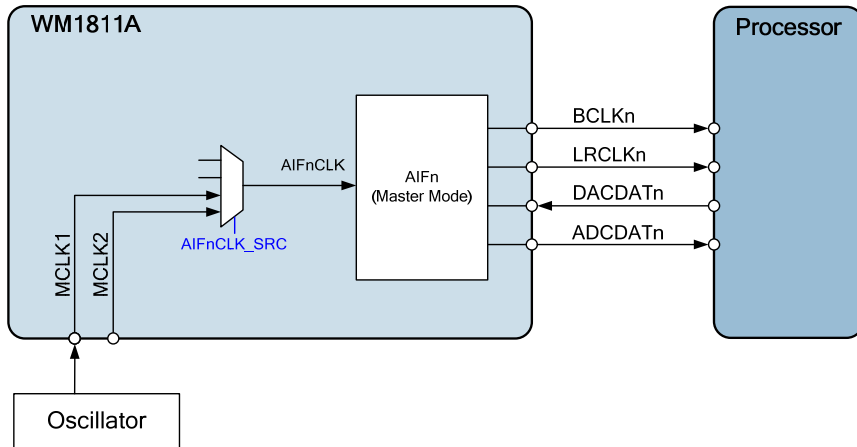

Figure 92 AIF Master Mode, using MCLK as Reference

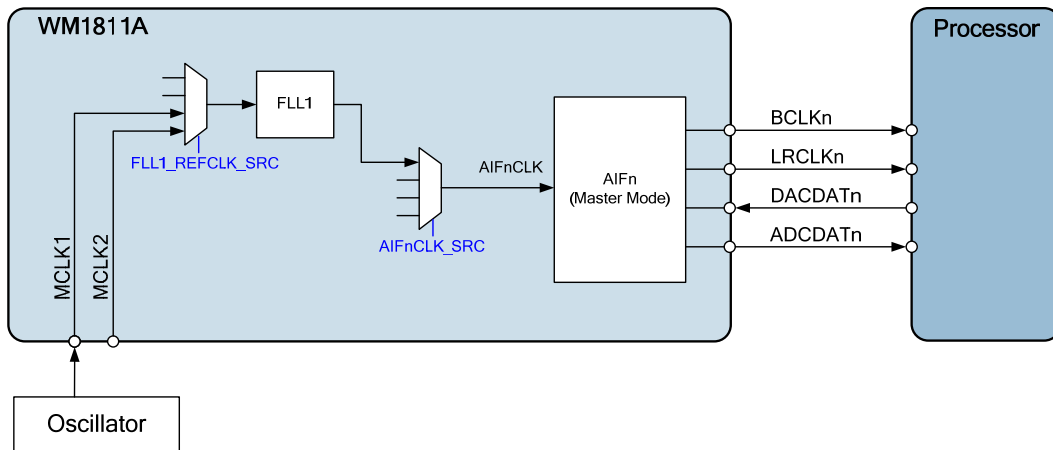

Figure 93 AIF Master Mode, using MCLK and FLL as Reference

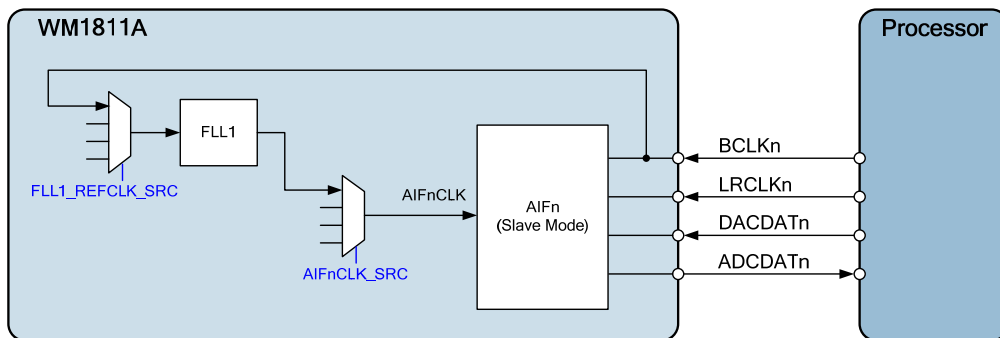

Figure 94 AIF Slave Mode, using BCLK and FLL as Reference

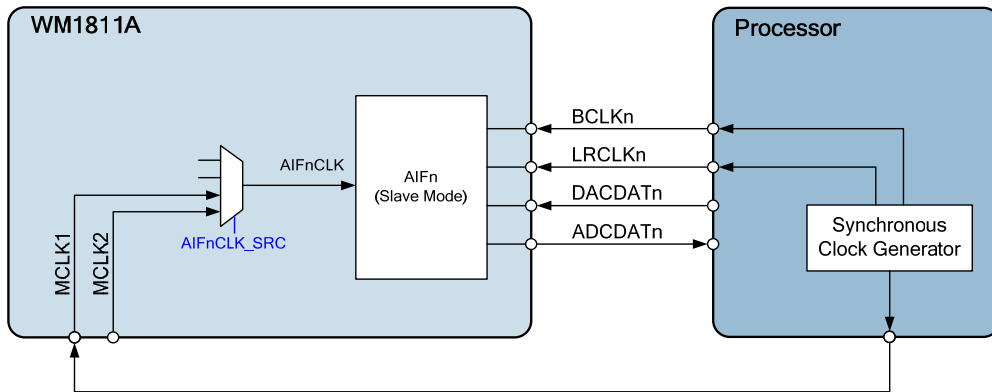

Figure 95 AIF Slave Mode, using MCLK as Reference

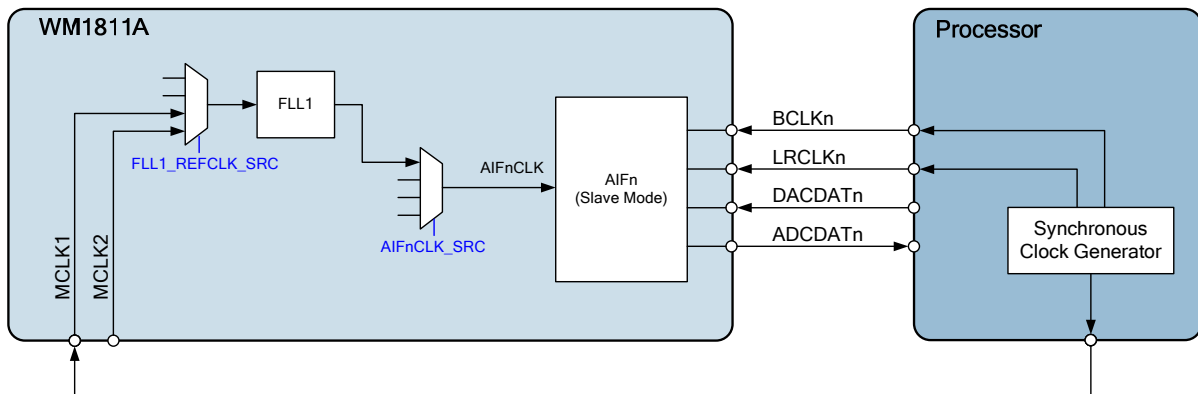

Figure 96 AIF Slave Mode, using MCLK and FLL as Reference

**PCB LAYOUT CONSIDERATIONS**

Poor PCB layout will degrade the performance and be a contributory factor in EMI, ground bounce and resistive voltage losses. All external components should be placed as close to the WM1811A device as possible, with current loop areas kept as small as possible. Specific factors relating to Class D loudspeaker connection are detailed below.

**CLASS D LOUDSPEAKER CONNECTION**

Long, exposed PCB tracks or connection wires will emit EMI. The distance between the WM1811A and the loudspeaker should therefore be kept as short as possible. Where speakers are connected to the PCB via a cable form, it is recommended that a shielded twisted pair cable is used. The shield should be connected to the main system, with care taken to ensure ground loops are avoided.

Further reduction in EMI can be achieved using PCB ground (or VDD) planes and also by using passive LC components to filter the Class D switching waveform. When passive filtering is used, low ESR components should be chosen in order to minimise the series resistance between the WM1811A and the speaker, maximising the power efficiency.

LC passive filtering will usually be effective at reducing EMI at frequencies up to around 30MHz. To reduce emissions at higher frequencies, ferrite beads can also be used. These should be positioned as close to the device as possible.

These techniques for EMI reduction are illustrated in Figure 97.

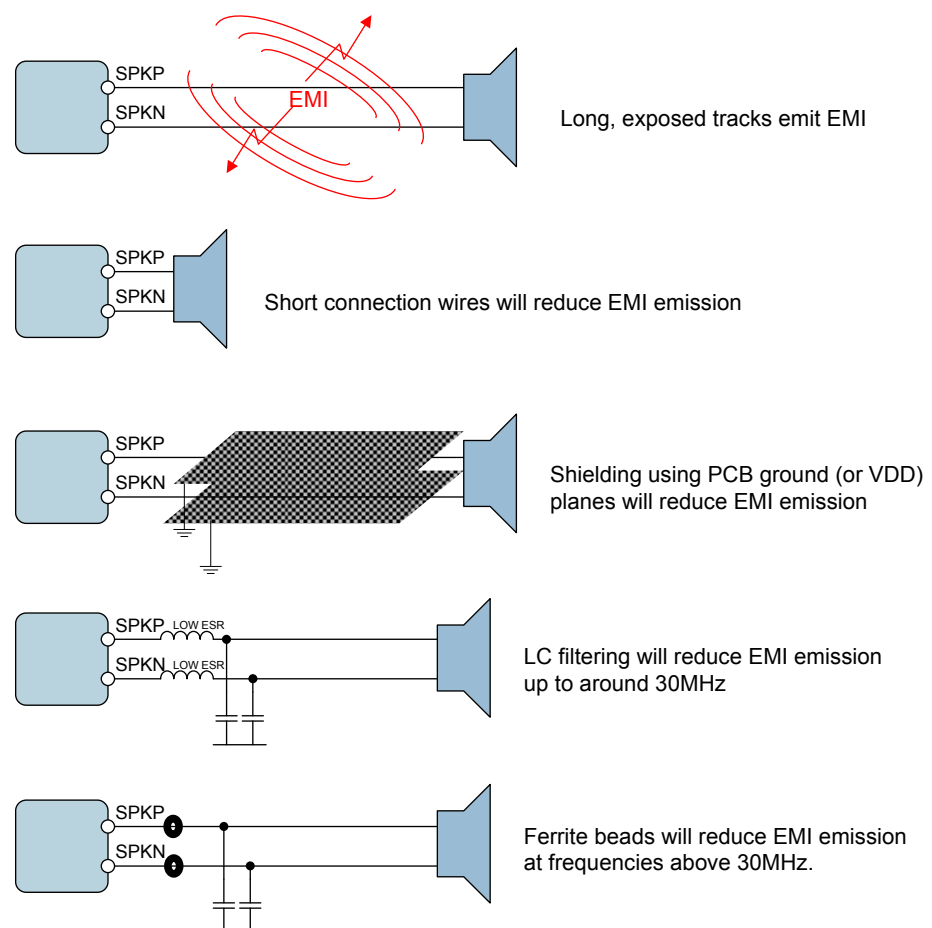

**Figure 97 EMI Reduction Techniques**

**PACKAGE DIMENSIONS**

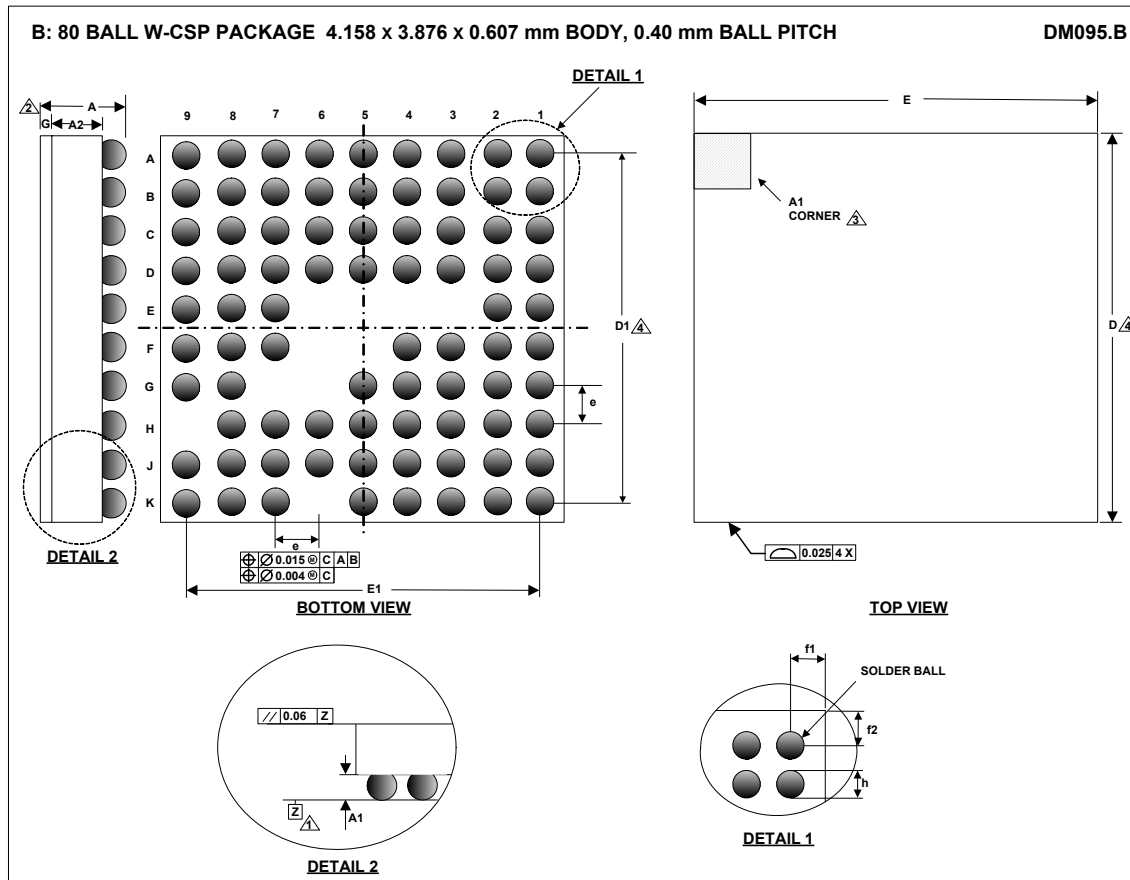

Symbols	Dimensions (mm)			NOTE
	MIN	NOM	MAX	
A	0.573	0.607	0.641	
A1	0.172	0.202	0.232	
A2	0.367	0.383	0.399	
D	4.133	4.158	4.183	4
D1		3.600 BSC		
E	3.851	3.876	3.901	4
E1		3.200 BSC		
e		0.400 BSC		5
f1		0.338 BSC		8
f2		0.279 BSC		9
g		0.022		
h	0.258	0.262	0.266	

- NOTES:
1. PRIMARY DATUM -Z- AND SEATING PLANE ARE DEFINED BY THE SPHERICAL CROWNS OF THE SOLDER BALLS.
  2. THIS DIMENSION INCLUDES STAND-OFF HEIGHT 'A1', SILICON THICKNESS AND BACKSIDE COATING.
  3. A1 CORNER IS IDENTIFIED BY INK/LASER MARK ON TOP PACKAGE.
  4. BILATERAL TOLERANCE ZONE IS APPLIED TO EACH SIDE OF THE PACKAGE BODY.
  5. 'e' REPRESENTS THE BASIC SOLDER BALL GRID PITCH.
  6. THIS DRAWING IS SUBJECT TO CHANGE WITHOUT NOTICE.
  7. FOLLOWS JEDEC DESIGN GUIDE MO-211-C.
  8. f1 = NOMINAL DISTANCE OF BALL CENTRE TO DIE EDGE X AXIS (AS PER POD) – APPLICABLE TO ALL CORNERS OF DIE.
  9. f2 = NOMINAL DISTANCE OF DIE CENTRE TO DIE EDGE IN Y AXIS (AS PER POD) – APPLICABLE TO ALL CORNERS OF DIE.

## IMPORTANT NOTICE

Wolfson Microelectronics plc ("Wolfson") products and services are sold subject to Wolfson's terms and conditions of sale, delivery and payment supplied at the time of order acknowledgement.

Wolfson warrants performance of its products to the specifications in effect at the date of shipment. Wolfson reserves the right to make changes to its products and specifications or to discontinue any product or service without notice. Customers should therefore obtain the latest version of relevant information from Wolfson to verify that the information is current.

Testing and other quality control techniques are utilised to the extent Wolfson deems necessary to support its warranty. Specific testing of all parameters of each device is not necessarily performed unless required by law or regulation.

In order to minimise risks associated with customer applications, the customer must use adequate design and operating safeguards to minimise inherent or procedural hazards. Wolfson is not liable for applications assistance or customer product design. The customer is solely responsible for its selection and use of Wolfson products. Wolfson is not liable for such selection or use nor for use of any circuitry other than circuitry entirely embodied in a Wolfson product.

Wolfson's products are not intended for use in life support systems, appliances, nuclear systems or systems where malfunction can reasonably be expected to result in personal injury, death or severe property or environmental damage. Any use of products by the customer for such purposes is at the customer's own risk.

Wolfson does not grant any licence (express or implied) under any patent right, copyright, mask work right or other intellectual property right of Wolfson covering or relating to any combination, machine, or process in which its products or services might be or are used. Any provision or publication of any third party's products or services does not constitute Wolfson's approval, licence, warranty or endorsement thereof. Any third party trade marks contained in this document belong to the respective third party owner.

Reproduction of information from Wolfson datasheets is permissible only if reproduction is without alteration and is accompanied by all associated copyright, proprietary and other notices (including this notice) and conditions. Wolfson is not liable for any unauthorised alteration of such information or for any reliance placed thereon.

Any representations made, warranties given, and/or liabilities accepted by any person which differ from those contained in this datasheet or in Wolfson's standard terms and conditions of sale, delivery and payment are made, given and/or accepted at that person's own risk. Wolfson is not liable for any such representations, warranties or liabilities or for any reliance placed thereon by any person.

### ADDRESS:

Wolfson Microelectronics plc  
26 Westfield Road  
Edinburgh  
EH11 2QB  
United Kingdom

Tel :: +44 (0)131 272 7000

Fax :: +44 (0)131 272 7001

Email :: [sales@wolfsonmicro.com](mailto:sales@wolfsonmicro.com)



**REVISION HISTORY**

DATE	REV	DESCRIPTION OF CHANGES	PAGE	CHANGED BY
18/11/11	2.0	Initial version		PH
24/11/11	3.0	Maximum MICBIASn load capacitance noted in Electrical Characteristics. Specifications added for LINEOUTFB and HPOUT1FB ground noise rejection. CMRR specifications added for differential input paths.		PH
01/03/12	3.0	Description of JACKDET_LVL and JACKDET_MODE updated. System clocking updated - DBCLK is derived independently of TOCLK_ENA. Package dimensions and drawing updated. Additional details in Absolute Maximum Ratings. Clarification of Line Output discharge functions and associated Electrical Characteristics. Additional details provided for Headphone Enable sequence.		PH
11/09/12	3.0	PSRR values added to Electrical Characteristics. Updated Headphone Output Enable Sequence.		KOL
27/06/13	4.0	Final PSRR values added to Electrical Characteristics.		PH
01/11/13	4.1	Corrected symbols in Figures 89 and 90.		JMacD
04/08/14	4.2	Speaker Driver maximum output rating added	17	PH

## X-ON Electronics

Largest Supplier of Electrical and Electronic Components

*Click to view similar products for [Interface - CODECs](#) category:*

*Click to view products by [Cirrus](#) manufacturer:*

Other Similar products are found below :

[CS4205-KQZ](#) [ZL38015QCG1](#) [MAX98090AEWJ+T](#) [WM9713CLGEFLV](#) [LE58QL061BVC](#) [ADAU1777BCBZRL](#) [WM8944BECS/R](#)  
[TDA7293V-E](#) [WM8998ECS/R](#) [WM8778SEDS/V](#) [CS42L73-CRZR](#) [WM8750CJLGEFL](#) [STA529Q](#) [SSM2603CPZ-REEL](#)  
[TLV320AIC14IDBT](#) [TLV320AIC23BIPWRQ1](#) [TLV320AIC23IPW](#) [TVP5151PBSR](#) [MAX98090BETL+](#) [MAX98089ETN+](#)  
[MAX98089ETNT](#) [TLV320AIC34IZASR](#) [TLV320AIC3262IYZFR](#) [SA612AD/01.112](#) [MAX98090AETL+](#) [MAX9880AETM](#)  
[WM8962ECSN/R](#) [TLV320DAC3203IRGER](#) [WM8904CGEFL/RV](#) [6PAIC3106IRGZRQ1](#) [CS42436-DMZ](#) [TSCS25A3X1NDGXZAX](#)  
[BU94502CMUV-E2](#) [TDA8932BT/N2.112](#) [TDA8954J/N1.112](#) [ICS501MLFT](#) [ICS512MLF](#) [92HD73C1T5PRGIC1X](#)  
[92HD73C1X5PRGXC1X](#) [SSM2167-1RMZ](#) [AD1836AASZ](#) [AD1836ACSZ](#) [AD1928YSTZ](#) [AD1937WBSTZ](#) [AD1939WBSTZ](#)  
[AD73311ARSZ](#) [AD73311ARZ](#) [AD73311LARUZ](#) [AD73322LARUZ](#) [AD74111YRUZ](#)