

## Evaluation Board for CS5381

### Features

- Demonstrates recommended layout and grounding arrangements
- CS8406 generates S/PDIF, and EIAJ-340 compatible digital audio
- Requires only an analog signal source and power supplies for a complete Analog-to-Digital-Converter system

### Description

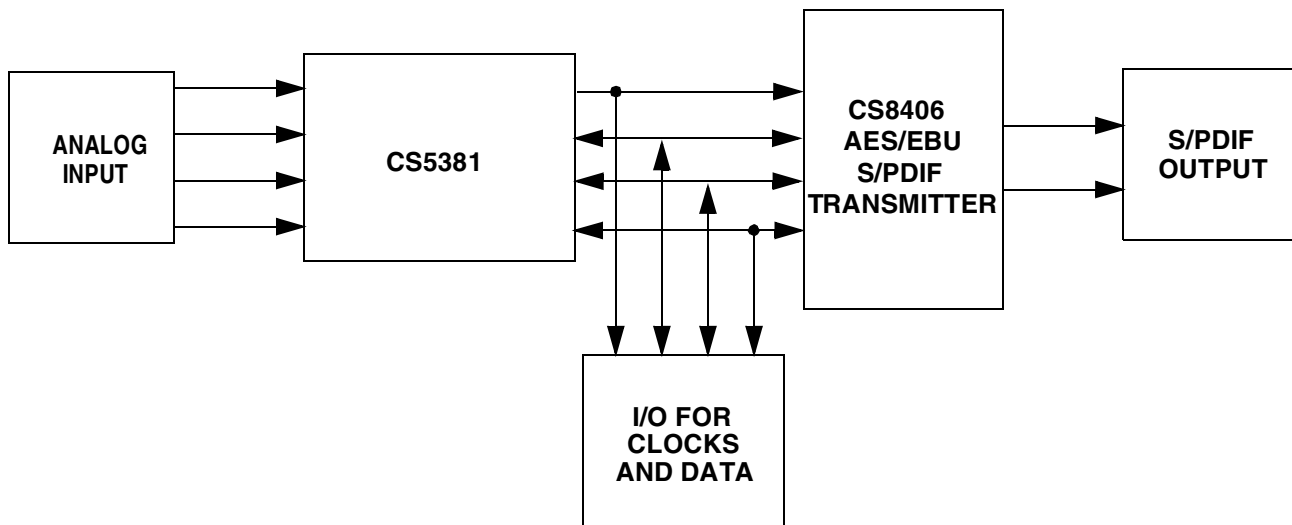
The CDB5381 evaluation board is an excellent means for quickly evaluating the CS5381 24-bit, stereo A/D converter. Evaluation requires a digital signal analyzer, an analog signal source, and a power supply.

Also included is a CS8406 digital audio interface transmitter which generates S/PDIF, and EIAJ-340 compatible audio data. The digital audio data is available via RCA phono and optical connectors.

### ORDERING INFORMATION

CDB5381

Evaluation Board



## TABLE OF CONTENTS

1. CDB5381 SYSTEM OVERVIEW .....	3
2. CS8406 DIGITAL AUDIO TRANSMITTER .....	3
3. INPUT/OUTPUT FOR CLOCKS AND DATA .....	3
4. POWER SUPPLY CIRCUITRY .....	3
5. GROUNDING AND POWER SUPPLY DECOUPLING .....	3
6. ANALOG INPUT FILTER .....	3

## LIST OF FIGURES

Figure 1. System Block Diagram and Signal Flow .....	5
Figure 2. Differential Analog Audio Input.....	6
Figure 3. CS5381 .....	7
Figure 4. Level Shifters .....	8
Figure 5. I/O for Clocks/Data.....	9
Figure 6. CS8406 Digital Audio Interface.....	9
Figure 7. Reset Circuit.....	10
Figure 8. Power Circuit.....	11
Figure 9. Top Layer Silkscreen .....	12
Figure 10. Top Layer .....	13
Figure 11. Bottom Layer.....	14

## LIST OF TABLES

Table 1. System Connections .....	4
Table 2. CDB5381 Jumper and Switch Settings .....	4

---

## Contacting Cirrus Logic Support

For all product questions and inquiries contact a Cirrus Logic Sales Representative.

To find one nearest you go to [www.cirrus.com](http://www.cirrus.com)

---

### IMPORTANT NOTICE

“Preliminary” product information describes products that are in production, but for which full characterization data is not yet available. “Advance” product information describes products that are in development and subject to development changes. Cirrus Logic, Inc. and its subsidiaries (“Cirrus”) believe that the information contained in this document is accurate and reliable. However, the information is subject to change without notice and is provided “AS IS” without warranty of any kind (express or implied). Customers are advised to obtain the latest version of relevant information to verify, before placing orders, that information being relied on is current and complete. All products are sold subject to the terms and conditions of sale supplied at the time of order acknowledgment, including those pertaining to warranty, patent infringement, and limitation of liability. No responsibility is assumed by Cirrus for the use of this information, including use of this information as the basis for manufacture or sale of any items, or for infringement of patents or other rights of third parties. This document is the property of Cirrus and by furnishing this information, Cirrus grants no license, express or implied under any patents, mask work rights, copyrights, trademarks, trade secrets or other intellectual property rights. Cirrus owns the copyrights associated with the information contained herein and gives consent for copies to be made of the information only for use within your organization with respect to Cirrus integrated circuits or other parts of Cirrus. This consent does not extend to other copying such as copying for general distribution, advertising or promotional purposes, or for creating any work for resale.

An export permit needs to be obtained from the competent authorities of the Japanese Government if any of the products or technologies described in this material and controlled under the “Foreign Exchange and Foreign Trade Law” is to be exported or taken out of Japan. An export license and/or quota needs to be obtained from the competent authorities of the Chinese Government if any of the products or technologies described in this material is subject to the PRC Foreign Trade Law and is to be exported or taken out of the PRC.

CERTAIN APPLICATIONS USING SEMICONDUCTOR PRODUCTS MAY INVOLVE POTENTIAL RISKS OF DEATH, PERSONAL INJURY, OR SEVERE PROPERTY OR ENVIRONMENTAL DAMAGE (“CRITICAL APPLICATIONS”). CIRRUS PRODUCTS ARE NOT DESIGNED, AUTHORIZED, OR WARRANTED TO BE SUITABLE FOR USE IN LIFE-SUPPORT DEVICES OR SYSTEMS OR OTHER CRITICAL APPLICATIONS. INCLUSION OF CIRRUS PRODUCTS IN SUCH APPLICATIONS IS UNDERSTOOD TO BE FULLY AT THE CUSTOMER’S RISK.

Cirrus Logic, Cirrus, and the Cirrus Logic logo designs are trademarks of Cirrus Logic, Inc. All other brand and product names in this document may be trademarks or service marks of their respective owners. Microwire is a trademark of National Semiconductor Corporation.

## 1. CDB5381 SYSTEM OVERVIEW

The CDB5381 evaluation board is an excellent means of quickly evaluating the CS5381. The CS8406 digital audio interface transmitter provides an easy interface to digital audio signal analyzers including the majority of digital audio test equipment.

The CDB5381 schematic has been partitioned into 7 schematics shown in Figure 2 through Figure 8. Each partitioned schematic is represented in the system diagram shown in Figure 1. Notice that the system diagram also includes the interconnections between the partitioned schematics.

## 2. CS8406 DIGITAL AUDIO TRANSMITTER

The system generates and encodes standard S/PDIF data using a CS8406 Digital Audio Transmitter (see Figure 6). The outputs of the CS8406 are RS422 compatible differential line drivers. The CS8406 supports both Left Justified and I<sup>2</sup>S data formats, as determined by the DIP switch, S2. A description of the CS8406 is included in the CS8406 datasheet.

## 3. INPUT/OUTPUT FOR CLOCKS AND DATA

The evaluation board has been designed to allow interfacing to external systems via the 10-pin header, J13. The schematic for the clock/data input/output is shown in Figure 5.

The CDB5381 allows some flexibility as to the generation of the clocks. When the CS5381 and CS8406 are in slave mode, the SCLK and LRCK must be provided via the header, J13. MCLK must be generated from the on board oscillator, Y1. This oscillator is socketed to allow other frequency oscillators to be used.

## 4. POWER SUPPLY CIRCUITRY

Power is supplied to the evaluation board by six binding posts (-12 V, +12 V, VD, VL, GND, +5 V), see Figure 8. -12 V and +12 V supply the input amplifiers while the VD input supplies the VD pin of the CS5381. VL supplies power to the VL pin of the CS5381 and to the level shifter circuits. The +5 V input supplies power to the +5 V digital circuitry and the VA pin of the CS5381.

## 5. GROUNDING AND POWER SUPPLY DECOUPLING

The CS5381 requires careful attention to power supply and grounding arrangements to optimize performance. Figure 3 details the power distribution used on this board. The decoupling capacitors are located as close to the CS5381 as possible. Extensive use of ground plane fill in the evaluation board yields large reductions in radiated noise.

## 6. ANALOG INPUT FILTER

The CDB5381 implements a fully differential analog input buffer, as shown in Figure 2. Note that there is no attenuation associated with the input buffer, so a 2 V<sub>rms</sub> differential input applied at the XLR connectors will provide a full-scale 2 V<sub>rms</sub> differential input to the CS5381.

CONNECTOR	INPUT/OUTPUT	SIGNAL PRESENT
-12 V	Input	-12 V power for the input op-amps
+12 V	Input	+12 V power for the input op-amps
VD	Input	+3.3 V to +5 V power for the CS5381
VL	Input	+2.5 V to +5 V power for the CS5381
GND	Input	Ground connection from power supply
+5 V	Input	+ 5 Volt power
AINL	Input	Differential analog input left channel
AINR	Input	Differential analog input right channel
Optical Output	Output	Digital audio output
Coax Output	Output	Digital audio output

**Table 1. System Connections**

JUMPER/SWITCH	PURPOSE	POSITION		FUNCTION SELECTED
J7	VD Power Source	ADJ	Open	Power from the Binding Post (J3)
		*+3.3 V	*Closed	Power from the +3.3 V Regulator
		+5 V		Power from the +5V Supply
J8	VL Power Source	ADJ	Open	Power from the Binding Post (J4)
		*+3.3 V	*Closed	Power from the +3.3 V Regulator
		+5 V		Power from the +5 V Supply
J13	Input/Output for clocks/data	-		-
S1	Reset for the CDB5381	-		-
S2	CDB5381 Configuration	M1/M0	Open	Hi
			*Closed	Low
		ADC	*Open	CS5381 in Master mode
			Closed	CS5381 in Slave mode
		HPF	Open	High-pass filter is disabled
			*Closed	High-pass filter is enabled
		DIV	Open	MCLK is divided by two internally by the CS5381
	*Closed	MCLK is not divided internally by the CS5381		
	IO_HDR	Open	Header J3 is an input for clocks	
		*Closed	Header J3 is an output for clocks and data	
	DIF	Open	Digital interface format set to I <sup>2</sup> S	
		*Closed	Digital interface format set to Left Justified	
	8406	Open	CS8406 in Master mode	
		*Closed	CS8406 in Slave mode	

**Table 2. CDB5381 Jumper and Switch Settings**

\* denotes default factory settings

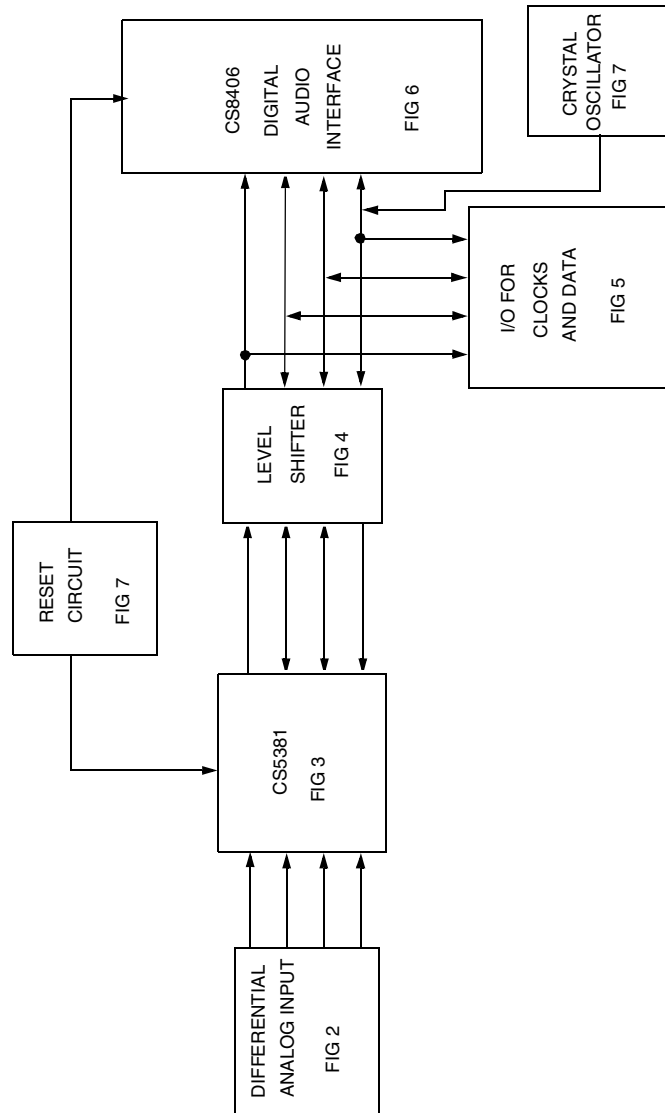
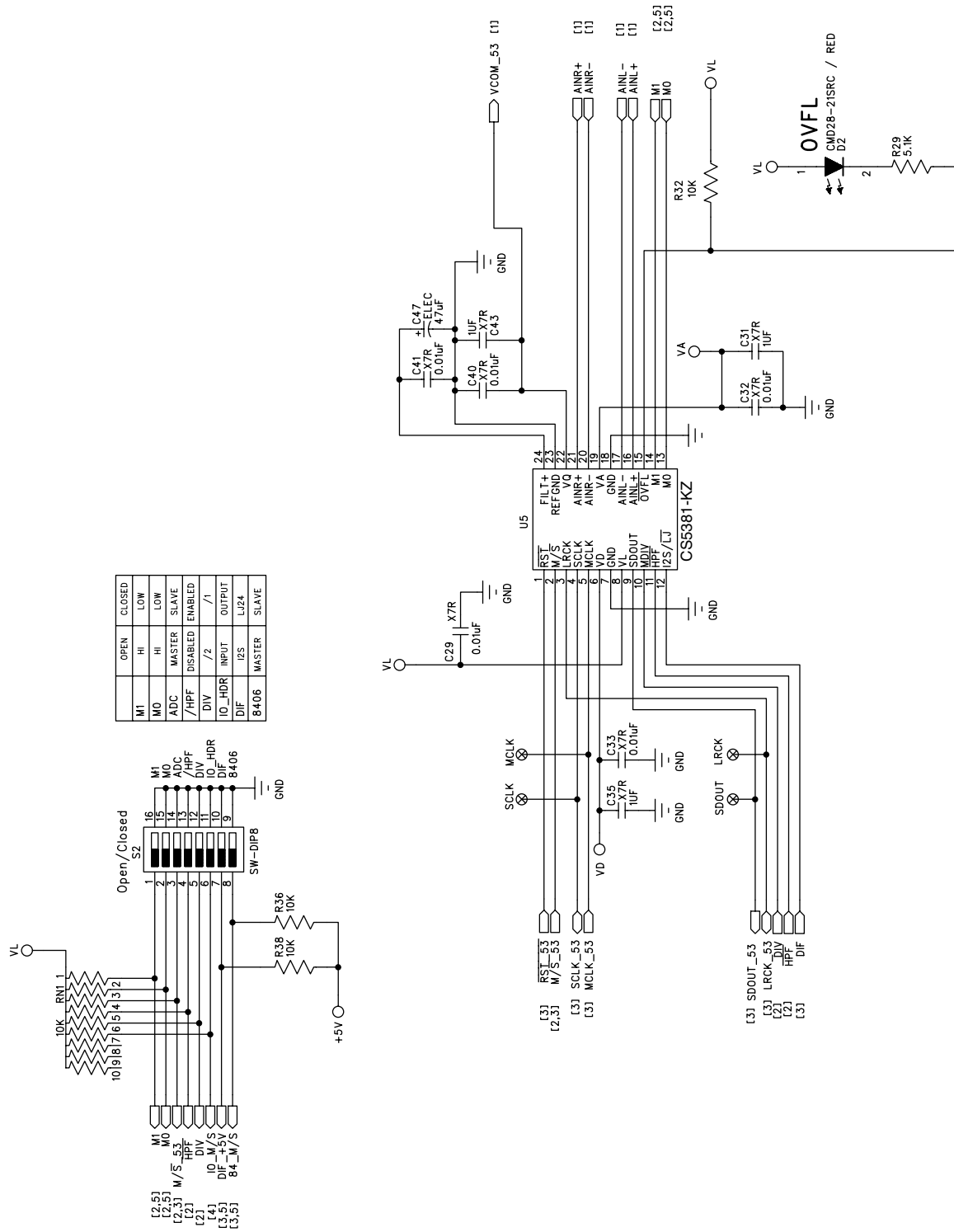
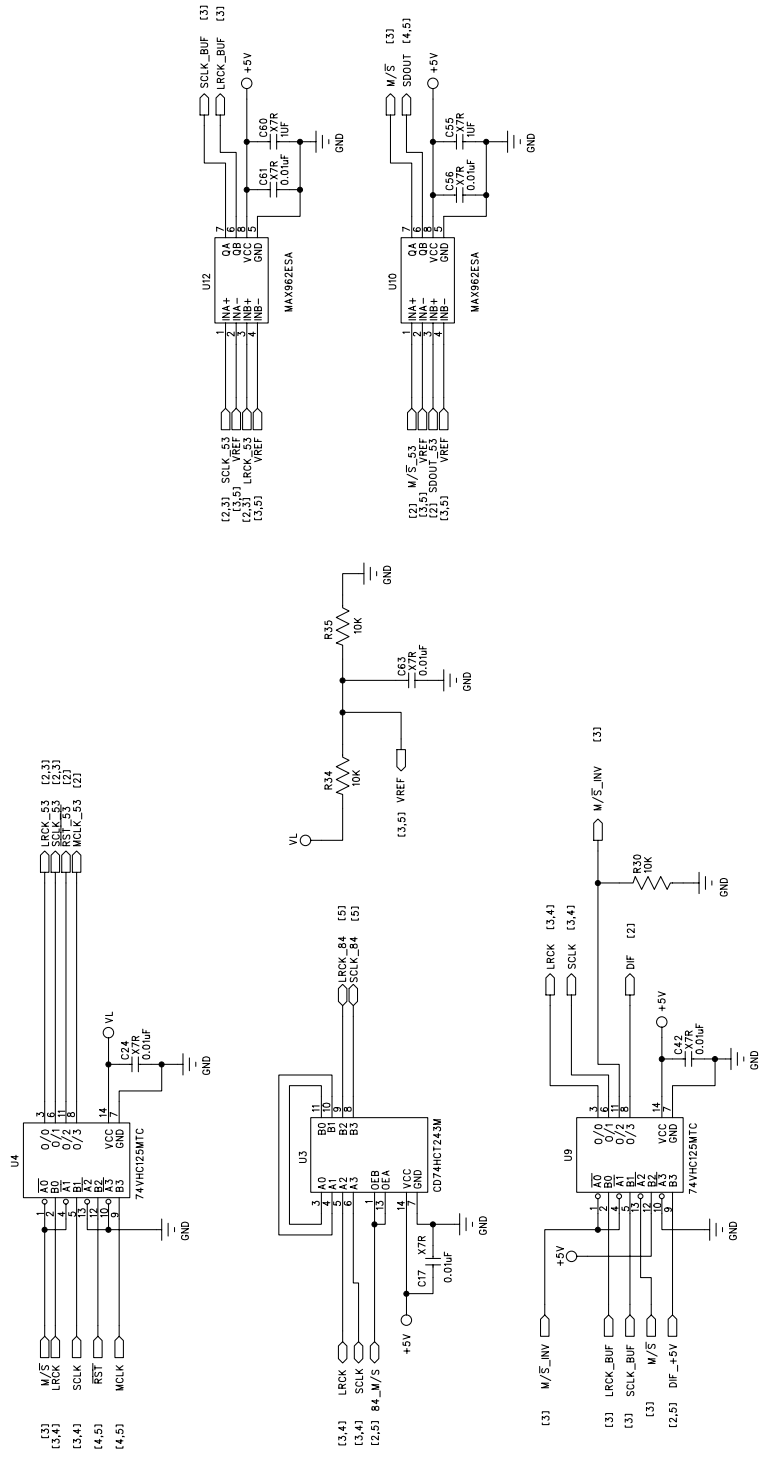


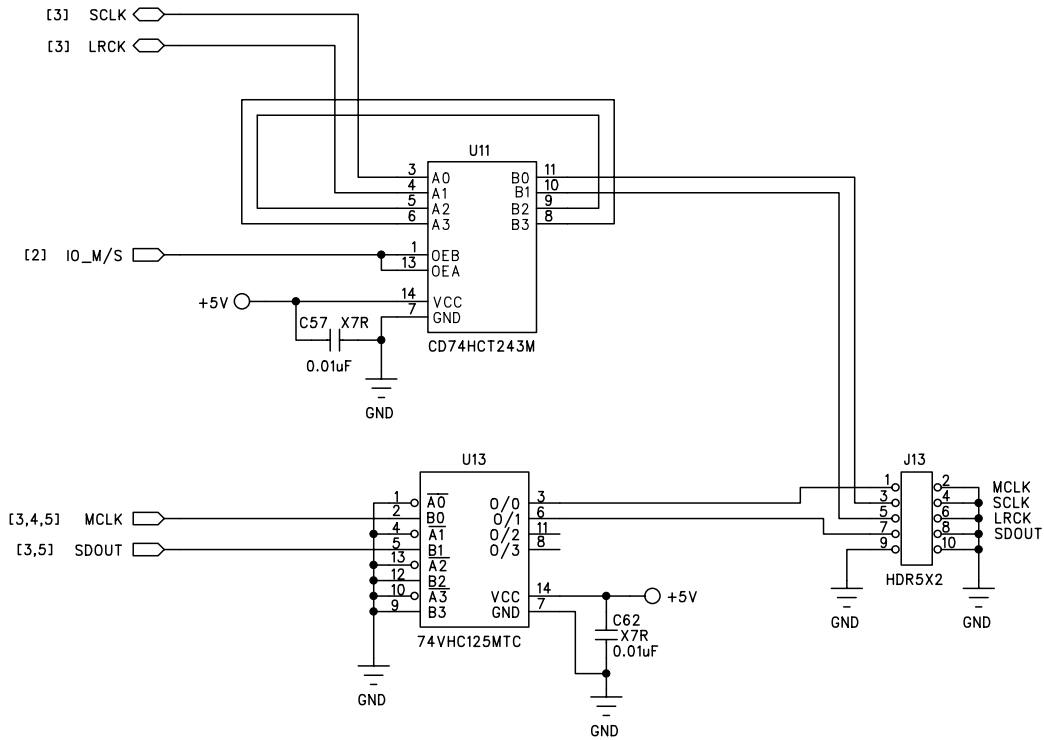
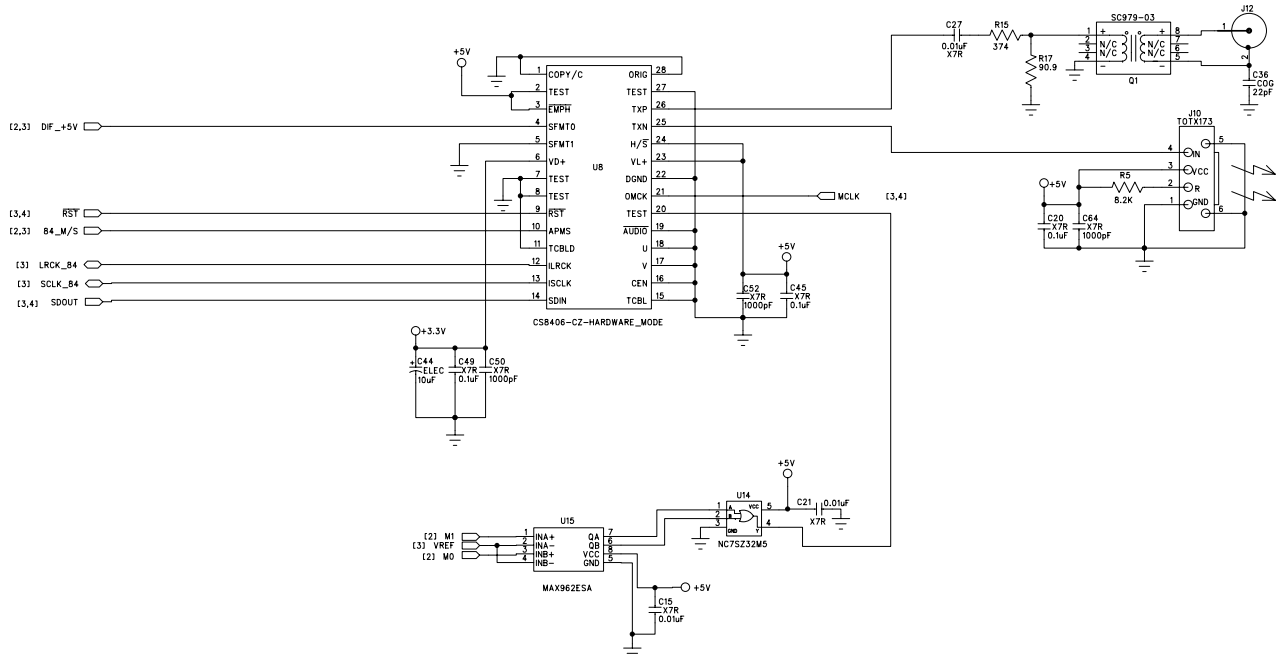
Figure 1. System Block Diagram and Signal Flow

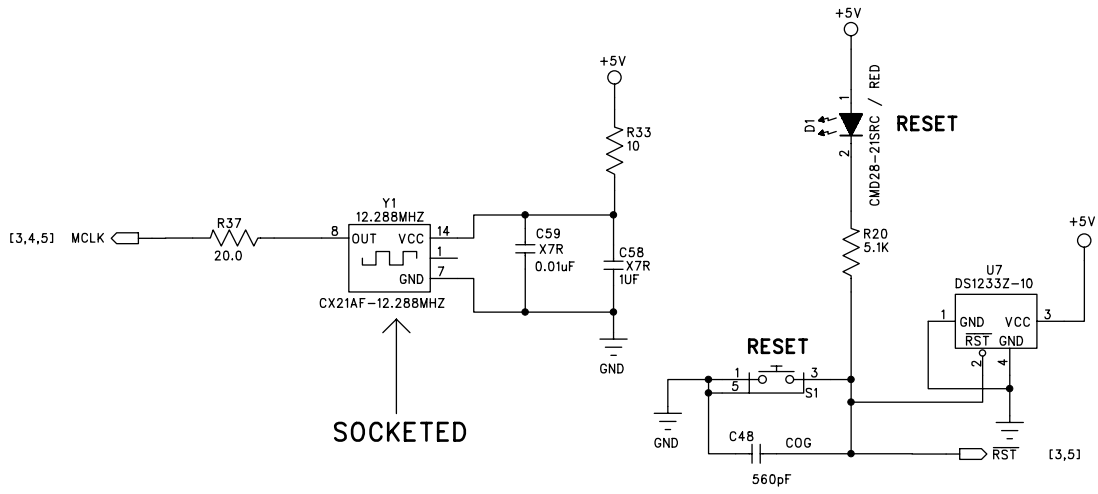



**Figure 3. CS5381**

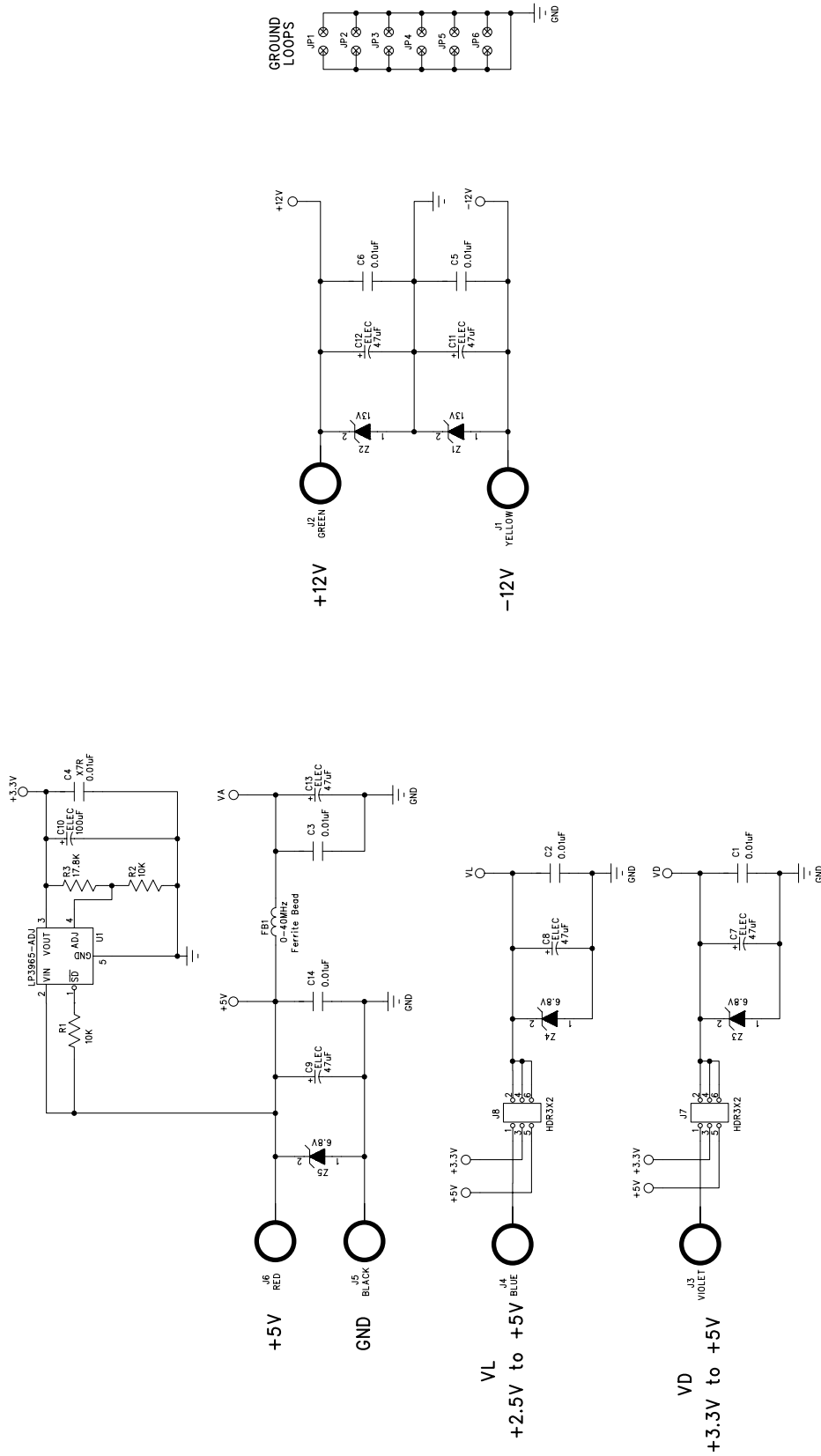

**Figure 4. Level Shifters**

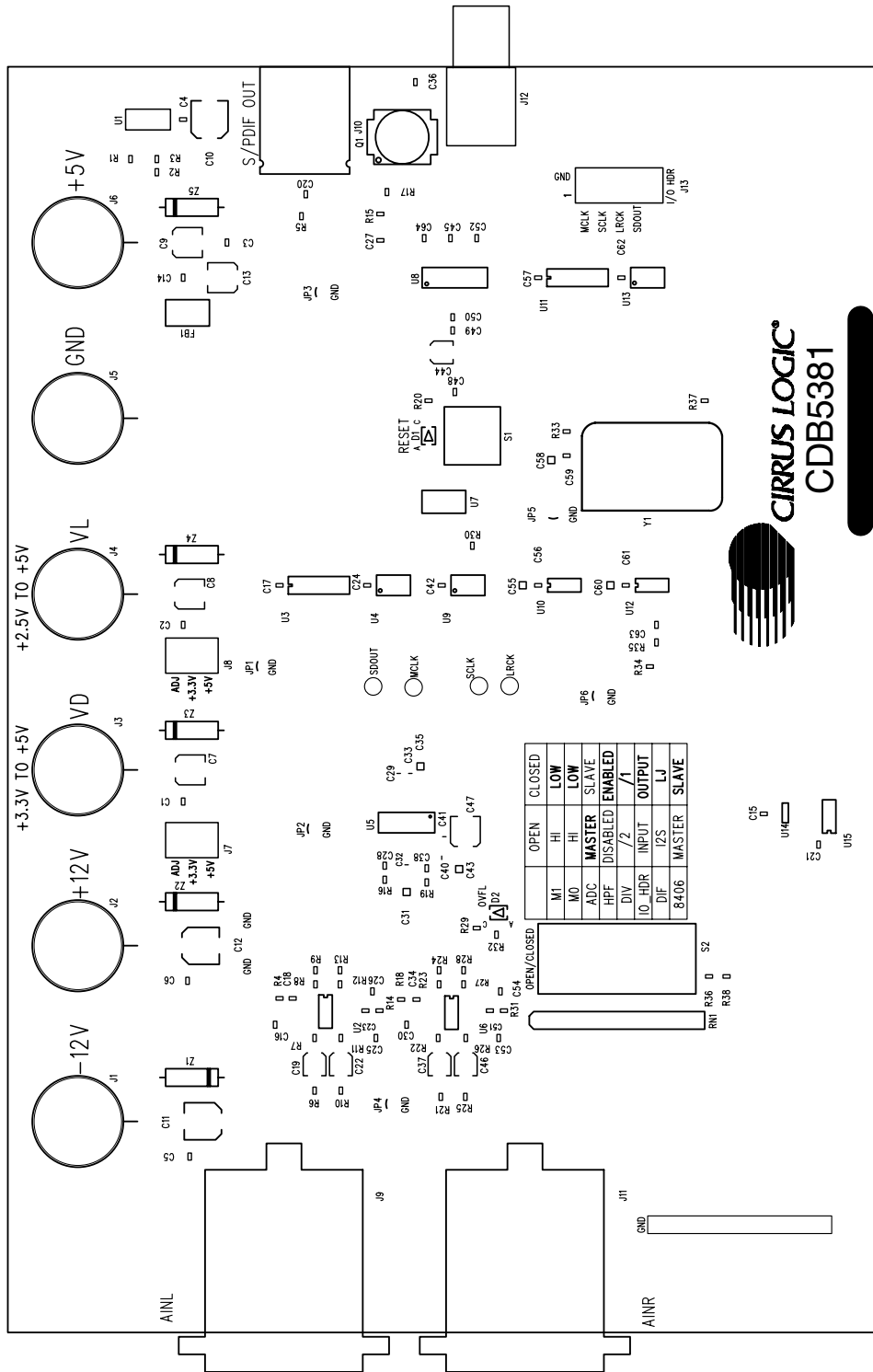



**Figure 5. I/O for Clocks/Data**

**Figure 6. CS8406 Digital Audio Interface**



**Figure 7. Reset Circuit**


**Figure 8. Power Circuit**


**Figure 9. Top Layer Silkscreen**

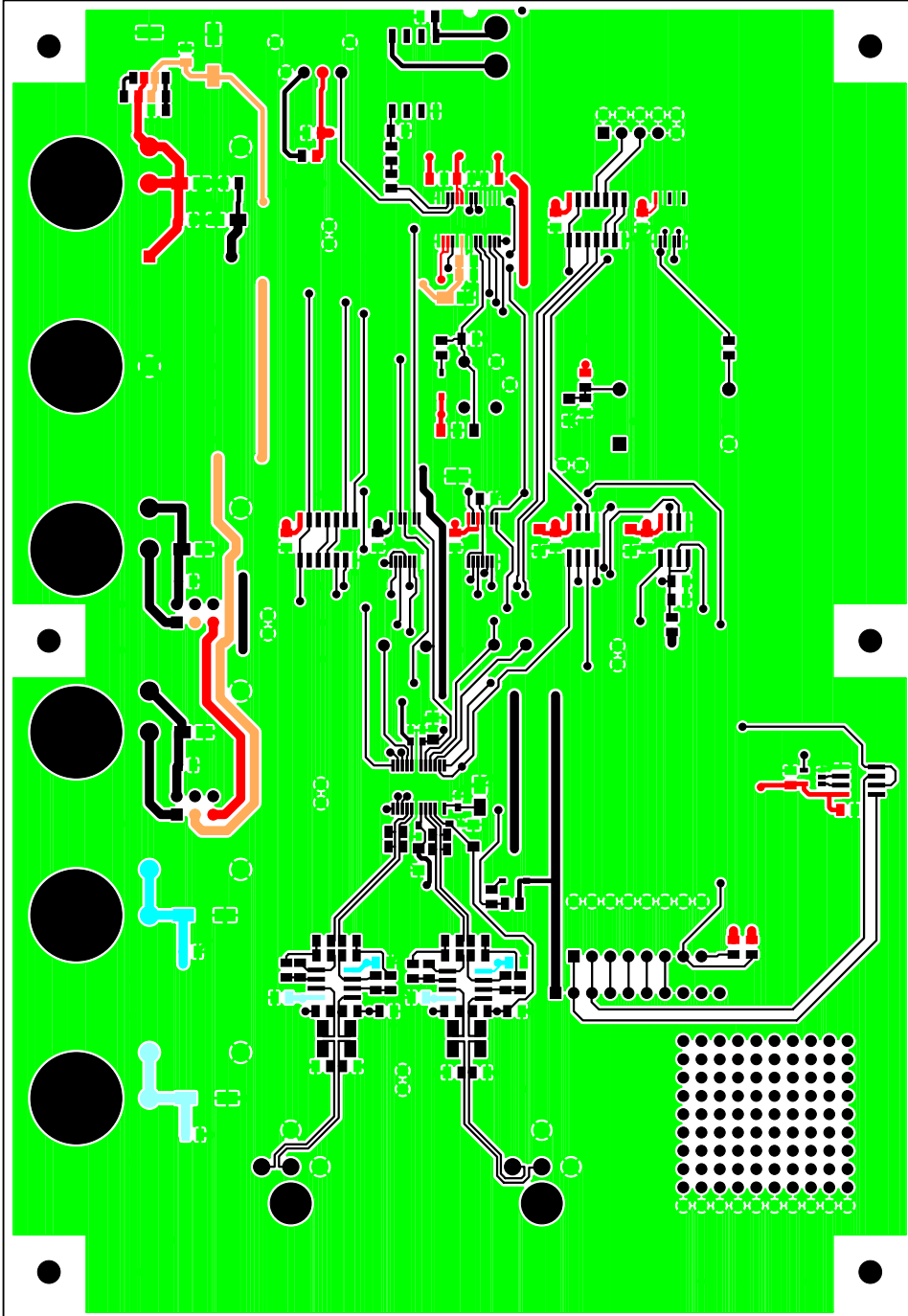


Figure 10. Top Layer

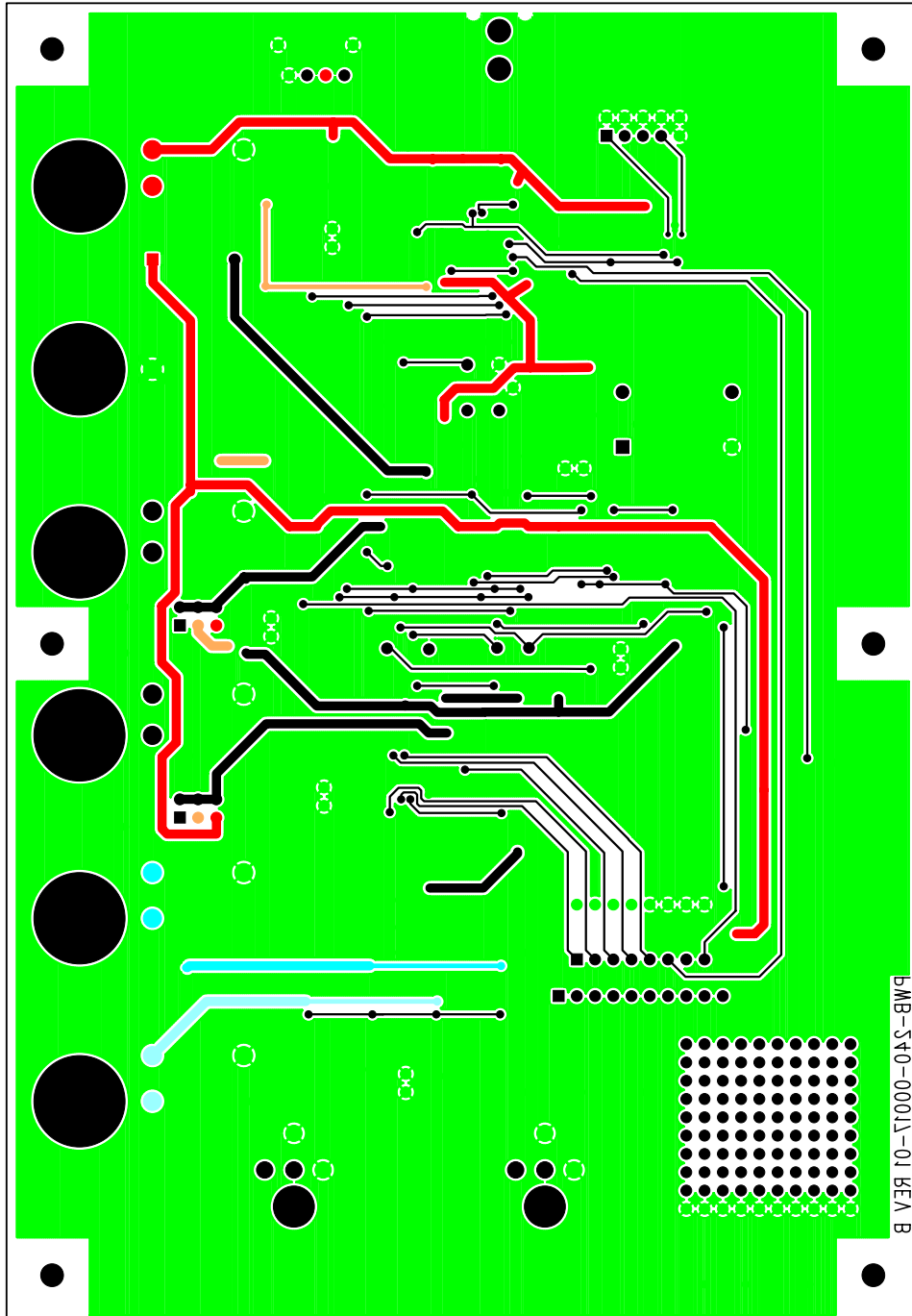


Figure 11. Bottom Layer

• **Notes** •

---



***CIRRUS LOGIC***<sup>®</sup>



## X-ON Electronics

Largest Supplier of Electrical and Electronic Components

*Click to view similar products for [Audio IC Development Tools](#) category:*

*Click to view products by [Cirrus Logic](#) manufacturer:*

Other Similar products are found below :

[LM4906MMBD](#) [LM4935RLEVAL](#) [LME49710NABD](#) [LME49740MABD](#) [LME49740NABD](#) [LME49860MABD](#) [LME49870MABD](#) [EVAL-AD1940AZ](#) [EVAL-ADAU1401AEBZ](#) [SRC4382EVM-PDK](#) [TLV320AIC36EVM-K](#) [TPA5052EVM](#) [TPA6136A2YFFEVM](#) [LM4562HABD](#) [LM4906LDBD](#) [LM4923LQBD](#) [LM4992SDBD](#) [LME49710MABD](#) [LME49713MABD](#) [LME49860NABD](#) [MAX98300EVKIT+WLP](#) [MAX9738EVKIT+](#) [MAX98358EVSYS#WLP](#) [MAX9723DEVKIT+](#) [EVAL-ADAV803EBZ](#) [LM4809MBD](#) [LM4674TLBD](#) [CDBWM8725-M-1](#) [CDBWM8533-M-1](#) [EV\\_ICS-40740-FX](#) [SDCK3](#) [PIM524](#) [MAX9723DEVCMODU+](#) [DEV-17737](#) [MAX9850EVCMOD2#](#) [EVALAHNBIM69D130V01TOBO1](#) [1063](#) [TAS5756MDCAEVM](#) [TLV320ADC3101EVM-K](#) [TLV320AIC3007EVM-K](#) [TLV320AIC3105EVM-K](#) [TLV320AIC3253EVM-K](#) [TPA2016D2EVM](#) [TPA2035D1EVM](#) [TPA2051D3YFFEVM](#) [TPA3107D2EVM](#) [TPA6120A2EVM](#) [TPA6132A2EVM2](#) [MIKROE-2454](#) [1381](#)