

Fractional-N Clock Multiplier with Internal LCO

Features

- ◆ Clock Multiplier / Jitter Reduction
 - Generates a Low Jitter 6 - 75 MHz Clock from a Jittery or Intermittent 50 Hz to 30 MHz Clock Source
- ◆ Internal LCO Reference Clock
- ◆ Highly Accurate PLL Multiplication Factor
 - Maximum Error Less Than 1 PPM in High-Resolution Mode
- ◆ One-Time Programmability
 - Configurable Hardware Control Pins
 - Configurable Auxiliary Output
- ◆ Minimal Board Space Required
 - No External Analog Loop-filter Components

General Description

The CS2300-OTP is an extremely versatile system clocking device that utilizes a programmable phase lock loop. The CS2300-OTP is based on a hybrid analog-digital PLL architecture comprised of a unique combination of a Delta-Sigma Fractional-N Frequency Synthesizer and a Digital PLL. This architecture allows for generation of a low-jitter clock relative to an external noisy synchronization clock with frequencies as low as 50 Hz. The CS2300-OTP has many configuration options which are set once prior to runtime. At runtime there are three hardware configuration pins available for mode and feature selection.

The CS2300-OTP is available in a 10-pin MSOP package in Commercial (-10°C to +70°C) grade. Customer development kits are also available for custom device prototyping, small production programming, and device evaluation. Please see [“Ordering Information” on page 27](#) for complete details.

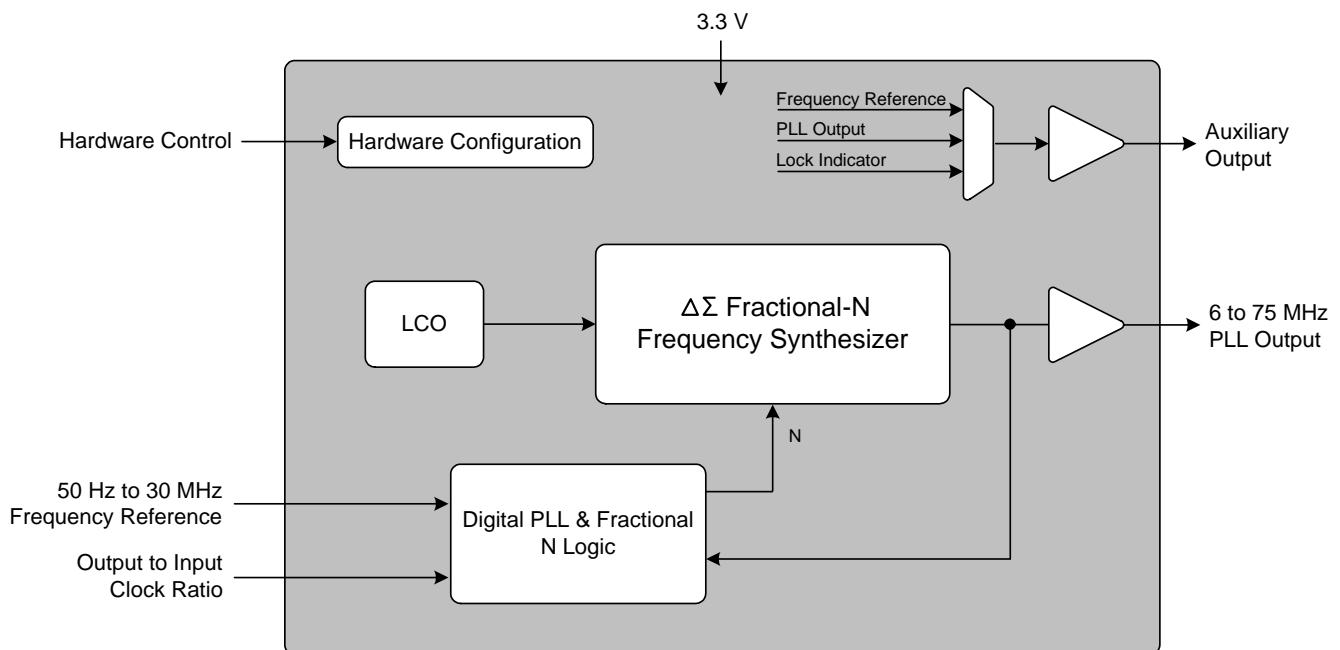

TABLE OF CONTENTS

1. PIN DESCRIPTION	4
2. TYPICAL CONNECTION DIAGRAM	5
3. CHARACTERISTICS AND SPECIFICATIONS	6
RECOMMENDED OPERATING CONDITIONS	6
ABSOLUTE MAXIMUM RATINGS	6
DC ELECTRICAL CHARACTERISTICS	6
AC ELECTRICAL CHARACTERISTICS	7
4. ARCHITECTURE OVERVIEW	8
4.1 Delta-Sigma Fractional-N Frequency Synthesizer	8
4.2 Hybrid Analog-Digital Phase Locked Loop	8
5. APPLICATIONS	10
5.1 One Time Programmability	10
5.2 Timing Reference Clock	10
5.3 Frequency Reference Clock Input, CLK_IN	10
5.3.1 CLK_IN Skipping Mode	10
5.3.2 Adjusting the Minimum Loop Bandwidth for CLK_IN	12
5.4 Output to Input Frequency Ratio Configuration	13
5.4.1 User Defined Ratio (R_{UD})	13
5.4.2 Manual Ratio Modifier (R-Mod)	14
5.4.3 Automatic Ratio Modifier (Auto R-Mod)	14
5.4.4 Effective Ratio (R_{EFF})	15
5.4.5 Ratio Configuration Summary	15
5.5 PLL Clock Output	16
5.6 Auxiliary Output	17
5.7 Mode Pin Functionality	17
5.7.1 M1 and M0 Mode Pin Functionality	17
5.7.2 M2 Mode Pin Functionality	18
5.7.2.1 M2 Configured as Output Disable	18
5.7.2.2 M2 Configured as R-Mod Enable	18
5.7.2.3 M2 Configured as Auto R-Mod Enable	18
5.7.2.4 M2 Configured as AuxOutSrc Override	18
5.8 Clock Output Stability Considerations	19
5.8.1 Output Switching	19
5.8.2 PLL Unlock Conditions	19
6. PARAMETER DESCRIPTIONS	20
6.1 Modal Configuration Sets	20
6.1.1 R-Mod Selection (RModSel[1:0])	20
6.1.2 Auxiliary Output Source Selection (AuxOutSrc[1:0])	21
6.1.3 Auto R-Modifier Enable (AutoRMod)	21
6.2 Ratio 0 - 3	21
6.3 Global Configuration Parameters	21
6.3.1 Clock Skip Enable (ClkSkipEn)	21
6.3.2 AUX PLL Lock Output Configuration (AuxLockCfg)	22
6.3.3 Enable PLL Clock Output on Unlock (ClkOutUnl)	22
6.3.4 Low-Frequency Ratio Configuration (LFRatioCfg)	22
6.3.5 M2 Pin Configuration (M2Config[2:0])	22
6.3.6 Clock Input Bandwidth (ClkIn_BW[2:0])	23
7. CALCULATING THE USER DEFINED RATIO	24
7.1 High Resolution 12.20 Format	24
7.2 High Multiplication 20.12 Format	24
8. PROGRAMMING INFORMATION	25
9. PACKAGE DIMENSIONS	26

THERMAL CHARACTERISTICS	26
10. ORDERING INFORMATION	27
11. REVISION HISTORY	27

LIST OF FIGURES

Figure 1. Typical Connection Diagram	5
Figure 2. Delta-Sigma Fractional-N Frequency Synthesizer	8
Figure 3. Hybrid Analog-Digital PLL	9
Figure 4. External Component Requirements for LCO	10
Figure 5. CLK_IN removed for $> 2^{23}$ LCO cycles	11
Figure 6. CLK_IN removed for $< 2^{23}$ LCO cycles but $> t_{CS}$	11
Figure 7. CLK_IN removed for $< t_{CS}$	12
Figure 8. Low bandwidth and new clock domain	12
Figure 9. High bandwidth with CLK_IN domain re-use	13
Figure 10. Ratio Feature Summary	16
Figure 11. PLL Clock Output Options	16
Figure 12. Auxiliary Output Selection	17
Figure 13. M2 Mapping Options	18
Figure 14. Parameter Configuration Sets	20

LIST OF TABLES

Table 1. Modal and Global Configuration	10
Table 2. Ratio Modifier	14
Table 3. Automatic Ratio Modifier	14
Table 4. Example Audio Oversampling Clock Generation from CLK_IN	15
Table 5. Example 12.20 R-Values	24
Table 6. Example 20.12 R-Values	24

1. PIN DESCRIPTION

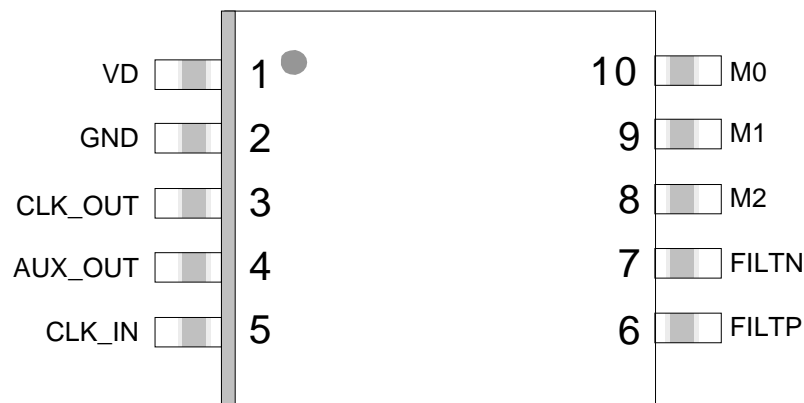

Pin Name	#	Pin Description
VD	1	Digital Power (Input) - Positive power supply for the digital and analog sections.
GND	2	Ground (Input) - Ground reference.
CLK_OUT	3	PLL Clock Output (Output) - PLL clock output.
AUX_OUT	4	Auxiliary Output (Output) - This pin outputs a buffered version of one of the input or output clocks, or a status signal, depending on configuration.
CLK_IN	5	Frequency Reference Clock Input (Input) - Clock input for the Digital PLL frequency reference.
FILTP	6	LCO Filter Connections (Input/Output) - These pins provide external supply filtering for the LCO.
FILTN	7	
M2	8	Mode Select (Input) - M2 is a configurable mode selection pin.
M1	9	Mode Select (Input) - M1 is a configurable mode selection pin.
M0	10	Mode Select (Input) - M0 is a configurable mode selection pin.

2. TYPICAL CONNECTION DIAGRAM

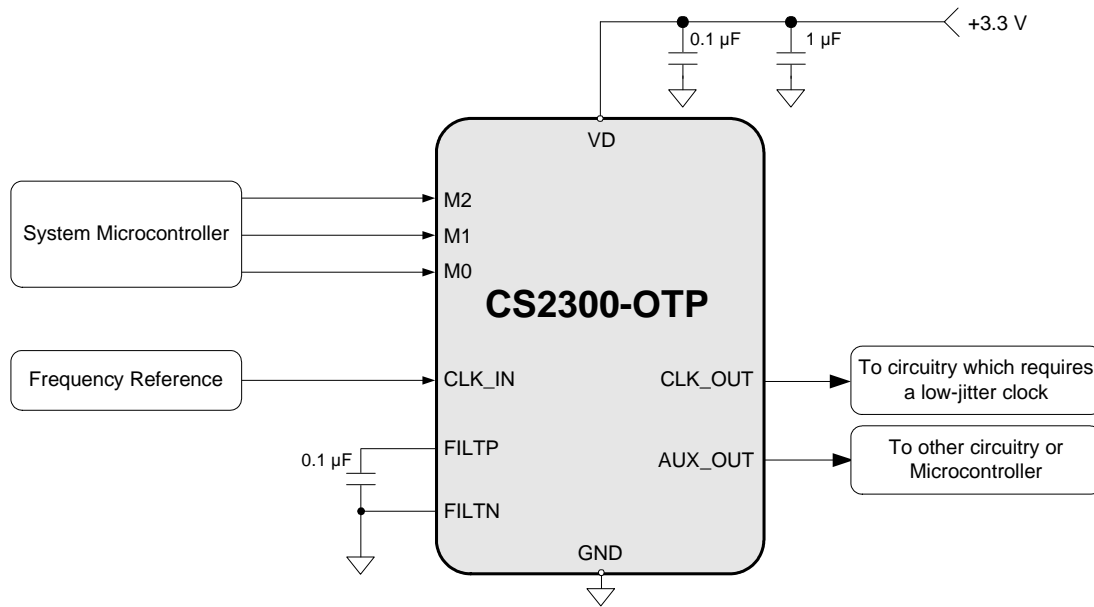

Figure 1. Typical Connection Diagram

3. CHARACTERISTICS AND SPECIFICATIONS

RECOMMENDED OPERATING CONDITIONS

GND = 0 V; all voltages with respect to ground. (Note 1)

Parameters	Symbol	Min	Typ	Max	Units
DC Power Supply	VD	3.1	3.3	3.5	V
Ambient Operating Temperature (Power Applied) Commercial Grade	T _{AC}	-10	-	+70	°C

Notes: 1. Device functional operation is guaranteed within these limits. Functionality is not guaranteed or implied outside of these limits. Operation outside of these limits may adversely affect device reliability.

ABSOLUTE MAXIMUM RATINGS

GND = 0 V; all voltages with respect to ground.

Parameters	Symbol	Min	Max	Units
DC Power Supply	VD	-0.3	6.0	V
Input Current	I _{IN}	-	±10	mA
Digital Input Voltage (Note 1)	V _{IN}	-0.3	VD + 0.4	V
Ambient Operating Temperature (Power Applied)	T _A	-55	125	°C
Storage Temperature	T _{stg}	-65	150	°C

WARNING: Operation at or beyond these limits may result in permanent damage to the device.

Notes: 1. The maximum over/under voltage is limited by the input current except on the power supply pin.

DC ELECTRICAL CHARACTERISTICS

Test Conditions (unless otherwise specified): VD = 3.1 V to 3.5 V; T_A = -10°C to +70°C (Commercial Grade).

Parameters	Symbol	Min	Typ	Max	Units
Power Supply Current - Unloaded (Note 2)	I _D	-	18	23	mA
Power Dissipation - Unloaded (Note 2)	P _D	-	59	76	mW
Input Leakage Current	I _{IN}	-	-	±10	µA
Input Capacitance	I _C	-	8	-	pF
High-Level Input Voltage	V _{IH}	70%	-	-	VD
Low-Level Input Voltage	V _{IL}	-	-	30%	VD
High-Level Output Voltage (I _{OH} = -1.2 mA)	V _{OH}	80%	-	-	VD
Low-Level Output Voltage (I _{OH} = 1.2 mA)	V _{OL}	-	-	20%	VD

Notes: 2. To calculate the additional current consumption due to loading (per output pin), multiply clock output frequency by load capacitance and power supply voltage.

For example, f_{CLK_OUT} (49.152 MHz) * C_L (15 pF) * VD (3.3 V) = 2.4 mA of additional current due to these loading conditions on CLK_OUT.

AC ELECTRICAL CHARACTERISTICS

Test Conditions (unless otherwise specified): $V_D = 3.1\text{ V to }3.5\text{ V}$; $T_A = -10^\circ\text{C to }+70^\circ\text{C}$ (Commercial Grade);
 $C_L = 15\text{ pF}$

Parameters	Symbol	Conditions	Min	Typ	Max	Units
Clock Input Frequency	$f_{\text{CLK_IN}}$		50 Hz	-	30	MHz
Clock Input Pulse Width (Note 3)	$PW_{\text{CLK_IN}}$	$f_{\text{CLK_IN}} < f_{\text{LCO}}/96$ $f_{\text{CLK_IN}} > f_{\text{LCO}}/96$	2 10	- -	- -	UI ns
Clock Skipping Timeout	t_{CS}	(Notes 4, 5)	20	-	-	ms
Clock Skipping Input Frequency	$f_{\text{CLK_SKIP}}$	(Note 5)	50 Hz	-	80	kHz
LC Oscillator Frequency	f_{LCO}		13.23	14.7	16.17	MHz
LC Oscillator Frequency drift vs. temp	Δf_{LCO}		64	83	110	ppm
PLL Clock Output Frequency	$f_{\text{CLK_OUT}}$		6	-	75	MHz
PLL Clock Output Duty Cycle	t_{OD}	Measured at $V_D/2$	48	50	52	%
Clock Output Rise Time	t_{OR}	20% to 80% of V_D	-	1.7	3.0	ns
Clock Output Fall Time	t_{OF}	80% to 20% of V_D	-	1.7	3.0	ns
Period Jitter (rms)	$t_{\text{JIT(rms)}}$	(Note 6)		35	110	ps
PLL Lock Time - CLK_IN (Note 7)	t_{LC}	$f_{\text{CLK_IN}} < 200\text{ kHz}$ $f_{\text{CLK_IN}} > 200\text{ kHz}$	- -	100 1	200 2	UI ms

- Notes:**
- 1 UI (unit interval) corresponds to t_{LCO} or $1/f_{\text{LCO}}$.
 - t_{CS} represents the time from the removal of CLK_IN by which CLK_IN must be re-applied to ensure that PLL_OUT continues while the PLL re-acquires lock. This timeout is based on the internal VCO frequency, with the minimum timeout occurring at the maximum VCO frequency. Lower VCO frequencies will result in larger values of t_{CS} .
 - Only valid in clock skipping mode; See "[CLK_IN Skipping Mode](#)" on page 10 for more information.
 - Sample size = 10,000 points; $\text{AuxOutSrc}[1:0] = 11$.
 - 1 UI (unit interval) corresponds to $t_{\text{CLK_IN}}$ or $1/f_{\text{CLK_IN}}$.

4. ARCHITECTURE OVERVIEW

4.1 Delta-Sigma Fractional-N Frequency Synthesizer

The core of the CS2300 is a Delta-Sigma Fractional-N Frequency Synthesizer which has very high-resolution for Input/Output clock ratios, low phase noise, very wide range of output frequencies and the ability to quickly tune to a new frequency. In very simplistic terms, the Fractional-N Frequency Synthesizer multiplies the LC Oscillator (LCO) by the value of N to generate the PLL output clock. The desired output to input clock ratio is the value of N that is applied to the delta-sigma modulator (see [Figure 2](#)).

The analog PLL based frequency synthesizer uses a low-jitter timing reference clock, the LCO, as a time and phase reference for the internal voltage controlled oscillator (VCO). The phase comparator compares the fractional-N divided clock with the original timing reference and generates a control signal. The control signal is filtered by the internal loop filter to generate the VCO's control voltage which sets its output frequency. The delta-sigma modulator modulates the loop integer divide ratio to get the desired fractional ratio between the reference clock and the VCO output (thus the duty cycle of the modulator sets the fractional value). This allows the design to be optimized for very fast lock times for a wide range of output frequencies without the need for external filter components.

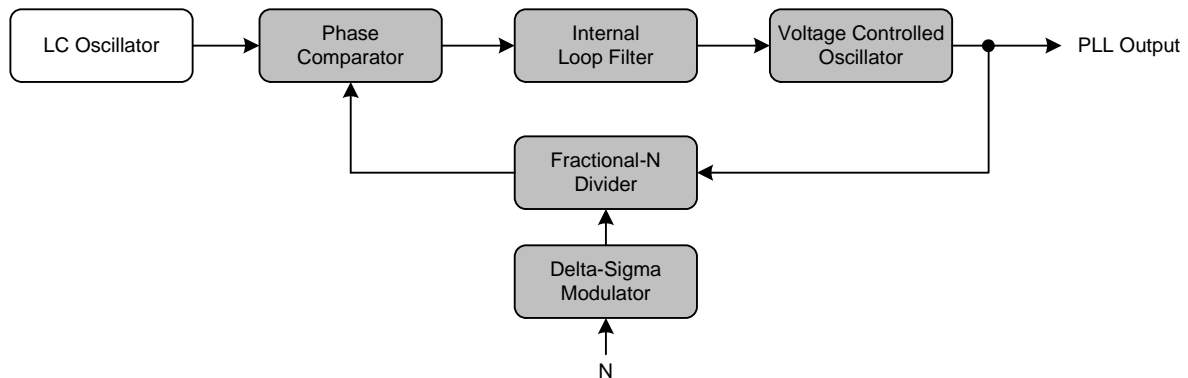

Figure 2. Delta-Sigma Fractional-N Frequency Synthesizer

4.2 Hybrid Analog-Digital Phase Locked Loop

The addition of the Digital PLL and Fractional-N Logic (shown in [Figure 3](#)) to the Fractional-N Frequency Synthesizer creates the Hybrid Analog-Digital Phase Locked Loop with many advantages over classical analog PLL techniques. These advantages include the ability to operate over extremely wide frequency ranges without the need to change external loop filter components while maintaining impressive jitter reduction performance. In the Hybrid architecture, the Digital PLL calculates the ratio of the PLL output clock to the frequency reference and compares that to the desired ratio. The digital logic generates a value of N which is then applied to the Fractional-N frequency synthesizer to generate the desired PLL output frequency. Notice that the frequency and phase of the LCO does not affect the output of the PLL since the digital control loop will correct for the PLL output. A major advantage of the Digital PLL is the ease with which the loop filter bandwidth can be altered. The PLL bandwidth is set to a wide-bandwidth mode to quickly achieve lock and then reduced for optimal jitter rejection.

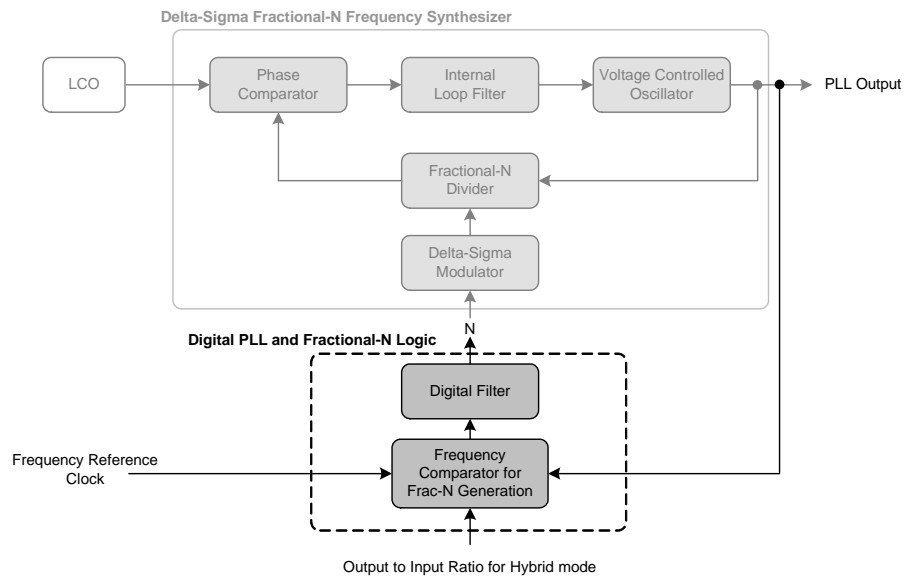

Figure 3. Hybrid Analog-Digital PLL

5. APPLICATIONS

5.1 One Time Programmability

The one time programmable (OTP) circuitry in the CS2300-OTP allows for pre-configuration of the device prior to use in a system. There are two types of parameters that are used for device pre-configuration: *modal* and *global*. The *modal* parameters are features which, when grouped together, create a modal configuration set (see [Figure 14 on page 20](#)). Up to four modal configuration sets can be permanently stored and then dynamically selected using the M[1:0] mode select pins (see [Table 1](#)). The *global* parameters are the remaining configuration settings which do not change with the mode select pins. The modal and global parameters can be pre-set at the factory or user programmed using the customer development kit, CDK2000; Please see “[Programming Information](#)” on [page 25](#) for more details.

Parameter Type	M[1:0] pins = 00	M[1:0] pins = 01	M[1:0] pins = 10	M[1:0] pins = 11
Modal	Configuration Set 0 Ratio 0	Configuration Set 1 Ratio 1	Configuration Set 2 Ratio 2	Configuration Set 3 Ratio 3
Global	Configuration settings set once for all modes.			

Table 1. Modal and Global Configuration

5.2 Timing Reference Clock

The internal LC oscillator is used to generate the timing reference clock. A single 0.1 μF cap must be connected between the FILTP and FILTN pins and FILTN must be connected to ground as shown in [Figure 4](#).

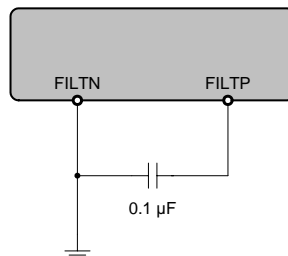

Figure 4. External Component Requirements for LCO

5.3 Frequency Reference Clock Input, CLK_IN

The frequency reference clock input (CLK_IN) is used by the Digital PLL and Fractional-N Logic block to dynamically generate a fractional-N value for the Frequency Synthesizer (see “[Hybrid Analog-Digital PLL](#)” on [page 9](#)). The Digital PLL first compares the CLK_IN frequency to the PLL output. The Fractional-N logic block then translates the desired ratio based off of CLK_IN to one based off of the internal LCO. This allows the low-jitter internal LCO to be used as the clock which the Frequency Synthesizer multiplies while maintaining synchronicity with the frequency reference clock through the Digital PLL. The allowable frequency range for CLK_IN is found in the “[AC Electrical Characteristics](#)” on [page 7](#).

5.3.1 CLK_IN Skipping Mode

CLK_IN skipping mode allows the PLL to maintain lock even when the CLK_IN signal has missing pulses for up to 20 ms (t_{CS}) at a time (see “[AC Electrical Characteristics](#)” on [page 7](#) for specifications). CLK_IN skipping mode can only be used when the CLK_IN frequency is below 80 kHz. The *ClkSkipEn* global parameter enables this function.

Regardless of the setting of the *ClkSkipEn* parameter the PLL output will continue for 2^{23} LCO cycles (518 ms to 634 ms) after CLK_IN is removed (see Figure 5). This is true as long as CLK_IN does not glitch or have an effective change in period as the clock source is removed, otherwise the PLL will interpret this as a change in frequency causing clock skipping and the 2^{23} LCO cycle time-out to be bypassed and the PLL to immediately unlock. If the prior conditions are met while CLK_IN is removed and 2^{23} LCO cycles pass, the PLL will unlock and the PLL_OUT state will be determined by the *ClkOutUnl* parameter; See “PLL Clock Output” on page 16. If CLK_IN is re-applied after such time, the PLL will remain unlocked for the specified time listed in the “AC Electrical Characteristics” on page 7 after which lock will be acquired and the PLL output will resume.

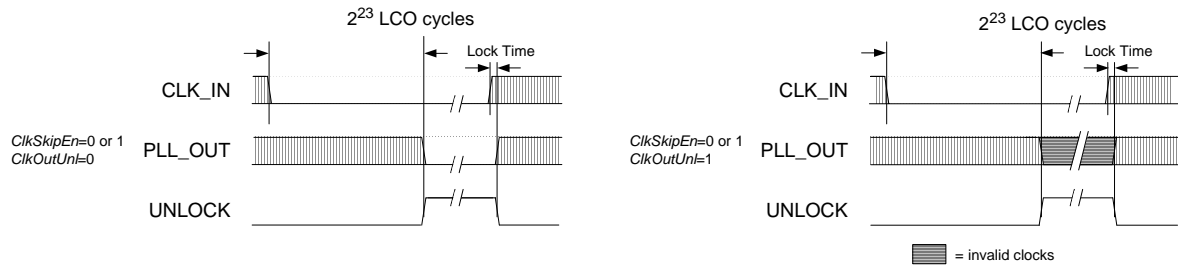

Figure 5. CLK_IN removed for $> 2^{23}$ LCO cycles

If CLK_IN is removed and then reapplied within 2^{23} LCO cycles but later than t_{CS} , the *ClkSkipEn* parameter will have no effect and the PLL output will continue until CLK_IN is re-applied (see Figure 6). Once CLK_IN is re-applied, the PLL will go unlocked only for the time it takes to acquire lock; the PLL_OUT state will be determined by the *ClkOutUnl* parameter during this time.

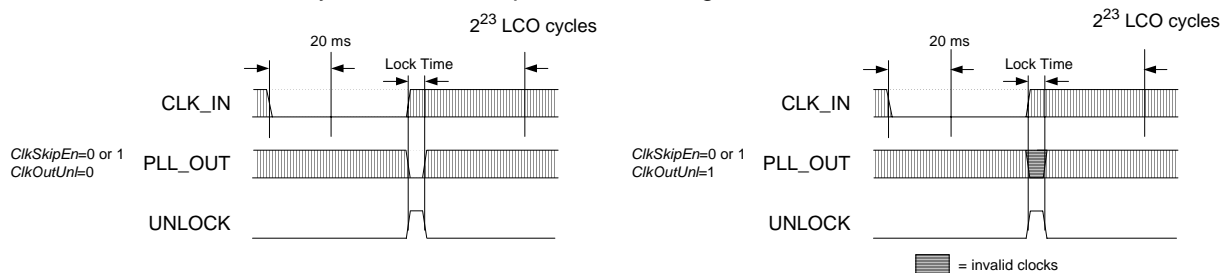

Figure 6. CLK_IN removed for $< 2^{23}$ LCO cycles but $> t_{CS}$

If CLK_IN is removed and then re-applied within t_{CS} , the *ClkSkipEn* parameter determines whether PLL_OUT continues while the PLL re-acquires lock (see Figure 7). When *ClkSkipEn* is disabled and CLK_IN is removed the PLL output will continue until CLK_IN is re-applied at which point the PLL will go unlocked only for the time it takes to acquire lock; the PLL_OUT state will be determined by the *ClkOutUnl* parameter during this time. When *ClkSkipEn* is enabled and CLK_IN is removed the PLL output clock will

remain continuous throughout the missing CLK_IN period including the time while the PLL re-acquires lock.

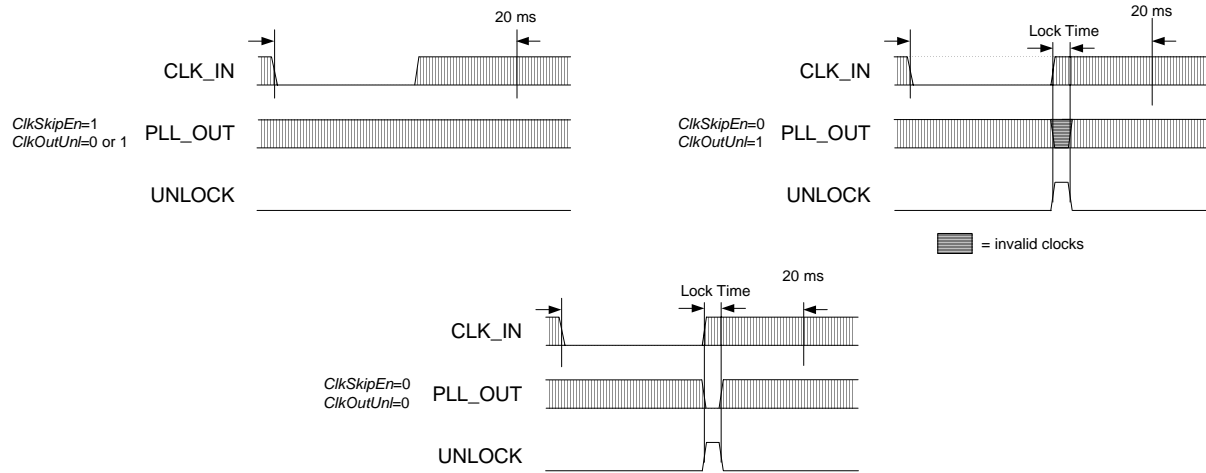

Figure 7. CLK_IN removed for t_{CS}

Referenced Control	Parameter Definition
ClkSkipEn.....	“Clock Skip Enable (ClkSkipEn)” on page 21
ClkOutUnl.....	“Enable PLL Clock Output on Unlock (ClkOutUnl)” on page 22

5.3.2 Adjusting the Minimum Loop Bandwidth for CLK_IN

The CS2300 allows the minimum loop bandwidth of the Digital PLL to be adjusted between 1 Hz and 128 Hz using the *ClkIn_BW[2:0]* global parameter. The minimum loop bandwidth of the Digital PLL directly affects the jitter transfer function; specifically, jitter frequencies below the loop bandwidth corner are passed from the PLL input directly to the PLL output without attenuation. In some applications it is desirable to have a very low minimum loop bandwidth to reject very low jitter frequencies, commonly referred to as wander. In others it may be preferable to remove only higher frequency jitter, allowing the input wander to pass through the PLL without attenuation.

Typically, applications in which the PLL_OUT signal creates a new clock domain from which all other system clocks and associated data are derived will benefit from the maximum jitter and wander rejection of the lowest PLL bandwidth setting. See [Figure 8](#).

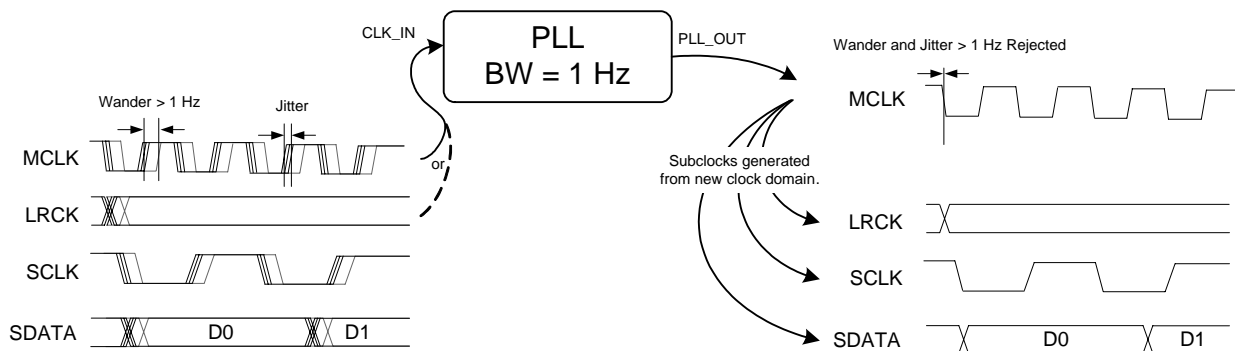

Figure 8. Low bandwidth and new clock domain

Systems in which some clocks and data are derived from the PLL_OUT signal while other clocks and data are derived from the CLK_IN signal will often require phase alignment of all the clocks and data in the system. See [Figure 9](#). If there is substantial wander on the CLK_IN signal in these applications, it may be necessary to increase the minimum loop bandwidth allowing this wander to pass through to the CLK_OUT

signal in order to maintain phase alignment. For these applications, it is advised to experiment with the loop bandwidth settings and choose the lowest bandwidth setting that does not produce system timing errors due to wandering between the clocks and data synchronous to the CLK_IN domain and those synchronous to the PLL_OUT domain.

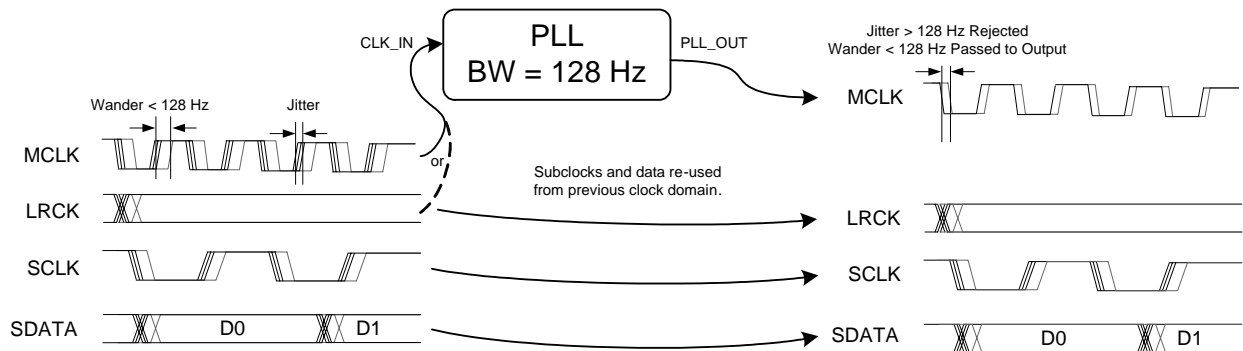

Figure 9. High bandwidth with CLK_IN domain re-use

While acquiring lock, the digital loop bandwidth is automatically set to a large value. Once lock is achieved, the digital loop bandwidth will settle to the minimum value selected by the *ClkIn_BW[2:0]* parameter.

Referenced Control	Parameter Definition
ClkIn_BW[2:0]	"Clock Input Bandwidth (ClkIn_BW[2:0])" on page 23

5.4 Output to Input Frequency Ratio Configuration

5.4.1 User Defined Ratio (R_{UD})

The User Defined Ratio, R_{UD} , is a 32-bit un-signed fixed-point number which determines the basis for the desired input to output clock ratio. Up to four different ratios, $Ratio_{0-3}$, can be stored in the CS2300's one time programmable memory. Selection between the four ratios is achieved by the M[1:0] mode select pins. The 32-bit R_{UD} can be expressed in either a high resolution (12.20) or high multiplication (20.12) format selectable by the *LFRatioCfg* global parameter.

The R_{UD} for high resolution (12.20) format is encoded with 12 MSBs representing the integer binary portion with the remaining 20 LSBs representing the fractional binary portion. The maximum multiplication factor is approximately 4096 with a resolution of 0.954 PPM in this configuration. See "Calculating the User Defined Ratio" on page 24 for more information.

The R_{UD} for high multiplication (20.12) format is encoded with 20 MSBs representing the integer binary portion with the remaining 12 LSBs representing the fractional binary portion. In this configuration, the maximum multiplication factor is approximately 1,048,575 with a resolution of 244 PPM. It is recommended that the 12.20 High-Resolution format be utilized whenever the desired ratio is less than 4096 since the output frequency accuracy of the PLL is directly proportional to the accuracy of the timing reference clock and the resolution of the R_{UD} .

Referenced Control	Parameter Definition
Ratio 0-3	"Ratio 0 - 3" on page 21
LFRatioCfg	"Low-Frequency Ratio Configuration (LFRatioCfg)" on page 22
M[1:0]	"M1 and M0 Mode Pin Functionality" on page 17

5.4.2 Manual Ratio Modifier (R-Mod)

The manual Ratio Modifier is used to internally multiply/divide the currently addressed R_{UD} ($Ratio_{0-3}$ stored in the register space remain unchanged). The available options for R-Mod are summarized in [Table 2 on page 14](#). R-Mod is enabled via the M2 pin in conjunction with the appropriate setting of the $M2Config[2:0]$ global parameter (see [Section 5.7.2 on page 18](#)).

RModSel[1:0]	R Modifier
00	0.5
01	0.25
10	0.125
11	0.0625

Table 2. Ratio Modifier

Referenced Control	Parameter Definition
Ratio 0-3.....	"Ratio 0 - 3" on page 21
RModSel[1:0]	"R-Mod Selection (RModSel[1:0])" section on page 20
M2Config[2:0].....	"M2 Pin Configuration (M2Config[2:0])" on page 22

5.4.3 Automatic Ratio Modifier (Auto R-Mod)

The Automatic R-Modifier uses the CLK_IN Frequency Range Detector to implement a frequency dependent multiply of the currently addressed R_{UD} as shown in [Table 3](#). The CLK_IN Frequency Range Detector determines the ratio between the frequency of the internal SysClk and the CLK_IN input signal. The result of the ratio measurement is the internal status signal called FsDetect[1:0].

Like with R-Mod, the $Ratio_{0-3}$ parameters stored in the one time programmable memory remain unchanged. The Automatic Ratio Modifier is enabled either by the *AutoRMod* modal parameter or via the M2 pin in conjunction with the appropriate setting of the $M2Config[2:0]$ global parameter (see [Section 5.7.2 on page 18](#)).

FsDetect[1:0]	f_{SysClk} / f_{CLK_IN}	Auto R Modifier
00	> 224	1
01	96 - 224	0.5
10	< 96	0.25

Table 3. Automatic Ratio Modifier

It is important to note that Auto R-Mod (if enabled) is applied in addition to any R-Mod already selected by the $RModSel[1:0]$ modal parameter and is used to calculate the Effective Ratio (see [Section 5.4.4 on page 15](#)).

Auto R-Mod can be used to generate the appropriate oversampling clock (MCLK) for audio A/D and D/A converters. For example, if the clock applied to CLK_IN is the audio sample rate, Fs (also known as the word, frame or Left/Right clock), SysClk is the internal LCO (between 13.23 MHz and 16.17 MHz), FsDe-

tect[1:0] would then reflect the frequency range of the audio sample rate. An R_{UD} of 512 generates the audio oversampling clocks as shown in [Table 4](#).

FsDetect[1:0]	Inferred Audio Sample Rate	Speed Mode (used for audio converters)	Audio Oversampling Clock
00	< [59 to 72] kHz	Single Speed	512 x
01	>[59 to 72] kHz and <[138 to 168] kHz	Double Speed	256 x
10	> [138 to 168] kHz	Quad Speed	128 x

Table 4. Example Audio Oversampling Clock Generation from CLK_IN

Referenced Control	Parameter Definition
Ratio 0-3.....	"Ratio 0 - 3" on page 21
RModSel[1:0]	"R-Mod Selection (RModSel[1:0])" section on page 20
AutoRMod	"Auto R-Modifier Enable (AutoRMod)" on page 21
M2Config[2:0].....	"M2 Pin Configuration (M2Config[2:0])" on page 22

5.4.4 Effective Ratio (R_{EFF})

The Effective Ratio (R_{EFF}) is an internal calculation comprised of R_{UD} and the appropriate modifiers, as previously described. R_{EFF} is calculated as follows:

$$R_{EFF} = R_{UD} \bullet R\text{-Mod} \bullet \text{Auto R-Mod}$$

Ratio modifiers which would produce an overflow or truncation of R_{EFF} should not be used. In all cases, the maximum and minimum allowable values for R_{EFF} are dictated by the frequency limits for both the input and output clocks as shown in the "[AC Electrical Characteristics](#)" on page 7.

Selection of the user defined ratio from the four stored ratios is made by using the M[1:0] pins.

Referenced Control	Parameter Definition
M[1:0] pins.....	"M1 and M0 Mode Pin Functionality" on page 17

5.4.5 Ratio Configuration Summary

The R_{UD} is the user defined ratio for which up to four different values ($Ratio_{0-3}$) can be stored in the one time programmable memory. The M[1:0] pins then select the user defined ratio to be used as well as the modal configuration set. The resolution/format for the R_{UD} is selectable. R-Mods are applied according to their settings. The user defined ratio, ratio modifier, and automatic ratio modifier make up the effective

ratio R_{EFF} , the final calculation used to determine the output to input clock ratio. The conceptual diagram in [Figure 10](#) summarizes the features involved in the calculation of the ratio values used to generate the fractional-N value which controls the Frequency Synthesizer. The subscript '4' indicates the modal parameters.

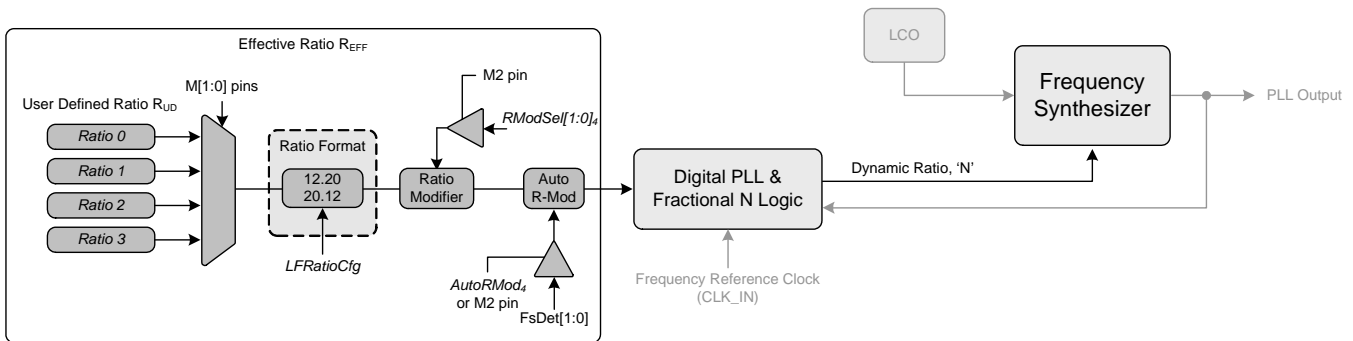

Figure 10. Ratio Feature Summary

Referenced Control	Parameter Definition
Ratio 0-3.....	"Ratio 0 - 3" on page 21
M[1:0] pins.....	"M1 and M0 Mode Pin Functionality" on page 17
LFRatioCfg.....	"Low-Frequency Ratio Configuration (LFRatioCfg)" on page 22
RModSel[1:0].....	"R-Mod Selection (RModSel[1:0])" section on page 20
AutoRMod.....	"Auto R-Modifier Enable (AutoRMod)" on page 21

5.5 PLL Clock Output

The PLL clock output pin (CLK_OUT) provides a buffered version of the output of the frequency synthesizer. The driver can be set to high-impedance with the M2 pin when the *M2Config[1:0]* global parameter is set to either 000 or 010. The output from the PLL automatically drives a static low condition while the PLL is unlocked (when the clock may be unreliable). This feature can be disabled by setting the *ClkOutUnl* global parameter, however the state CLK_OUT may then be unreliable during an unlock condition.

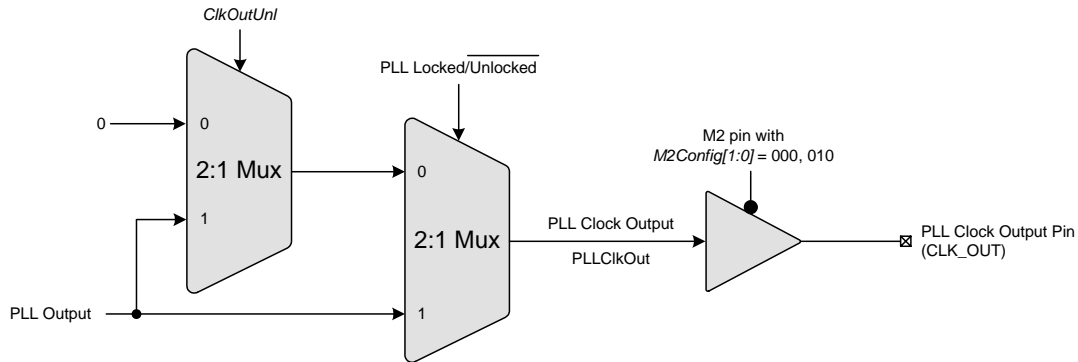

Figure 11. PLL Clock Output Options

Referenced Control	Parameter Definition
ClkOutUnl.....	"Enable PLL Clock Output on Unlock (ClkOutUnl)" on page 22
ClkOutDis.....	"M2 Configured as Output Disable" on page 18
M2Config[2:0].....	"M2 Pin Configuration (M2Config[2:0])" on page 22

5.6 Auxiliary Output

The auxiliary output pin (AUX_OUT) can be mapped, as shown in [Figure 12](#), to one of three signals: input clock (CLK_IN), additional PLL clock output (CLK_OUT), or a PLL lock indicator (Lock). The mux is controlled via the *AuxOutSrc[1:0]* modal parameter. If AUX_OUT is set to Lock, the *AuxLockCfg* global parameter is then used to control the output driver type and polarity of the LOCK signal (see [section 6.3.2 on page 22](#)). If AUX_OUT is set to CLK_OUT, the phase of the PLL Clock Output signal on AUX_OUT may differ from the CLK_OUT pin. The driver for the pin can be set to high-impedance using the M2 pin when the *M2Config[1:0]* global parameter is set to either 001 or 010.

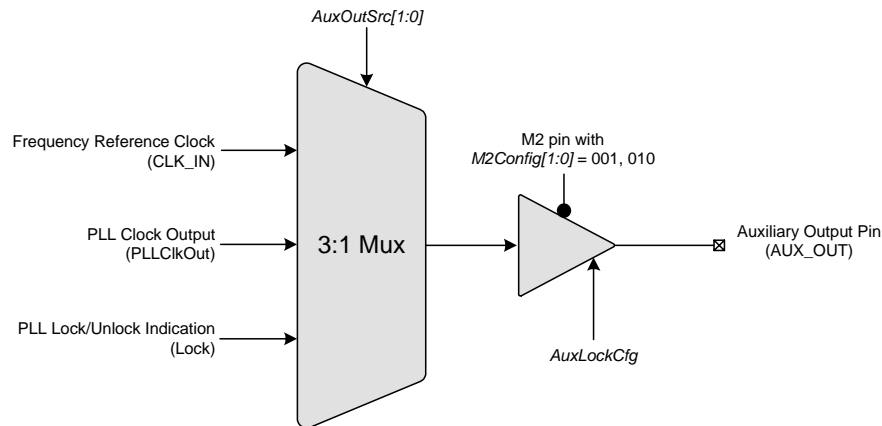

Figure 12. Auxiliary Output Selection

Referenced Control	Parameter Definition
AuxOutSrc[1:0].....	“Auxiliary Output Source Selection (AuxOutSrc[1:0])” on page 21
AuxOutDis.....	“M2 Configured as Output Disable” on page 18
AuxLockCfg.....	“AUX PLL Lock Output Configuration (AuxLockCfg)” section on page 22
M2Config[2:0].....	“M2 Pin Configuration (M2Config[2:0])” on page 22

5.7 Mode Pin Functionality

5.7.1 M1 and M0 Mode Pin Functionality

M[1:0] determine the functional mode of the device and select both the default User Defined Ratio and the set of modal parameters. The modal parameters are *RModSel[1:0]*, *AuxOutSrc[1:0]*, and *AutoRMod*. By modifying one or more of the modal parameters between the 4 sets, different functional configurations can be achieved. However, global parameters are fixed and the same value will be applied to each functional configuration. [Figure 14 on page 20](#) provides a summary of all parameters used by the device.

5.7.2 M2 Mode Pin Functionality

M2 usage is mapped to one of the optional special functions via the $M2Config[2:0]$ global parameter. Depending on what M2 is mapped to, it will either act as an output enable/disable pin or override certain modal parameters. Figure 13 summarizes the available options and the following sections will describe each option in more detail.

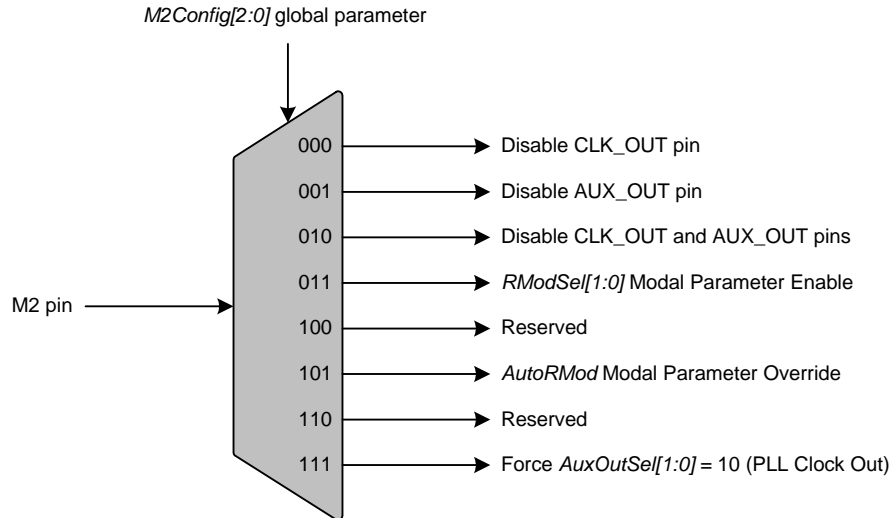

Figure 13. M2 Mapping Options

5.7.2.1 M2 Configured as Output Disable

If $M2Config[2:0]$ is set to either '000', '001', or '010', M2 becomes an output disable pin for one or both output pins. If M2 is driven 'low', the corresponding output(s) will be enabled, if M2 is driven 'high', the corresponding output(s) will be disabled.

5.7.2.2 M2 Configured as R-Mod Enable

If $M2Config[2:0]$ is set to '011', M2 becomes the R-Mod enable pin. It should be noted that M2 is the only way to enable R-Mod. Even though the $RModSel[1:0]$ modal parameter can be set arbitrarily for each configuration set, it will not take effect unless enabled via M2. If M2 is driven 'low', R-Mod will be disabled, if M2 is driven 'high' R-Mod will be enabled.

5.7.2.3 M2 Configured as Auto R-Mod Enable

If $M2Config[2:0]$ is set to '101', M2 becomes the Auto R-Mod enable pin and will override the $AutoRMod$ modal parameter. If M2 is driven 'low', Auto R-Mod will be disabled, if M2 is driven 'high' Auto R-Mod will be enabled.

5.7.2.4 M2 Configured as AuxOutSrc Override

If $M2Config[2:0]$ is set to '111', M2 when driven 'high' will override the $AuxOutSrc[1:0]$ modal parameter and force the AUX_OUT source to PLL Clock Output. When M2 is driven 'low', AUX_OUT will function according to $AuxOutSrc[1:0]$.

5.8 Clock Output Stability Considerations

5.8.1 Output Switching

The CS2300-OTP is designed such that re-configuration of the clock routing functions do not result in a partial clock period on any of the active outputs (CLK_OUT and/or AUX_OUT). In particular, enabling or disabling an output, and the automatic disabling of the output(s) during unlock will not cause a runt or partial clock period.

The following exceptions/limitations exist:

- Enabling/disabling AUX_OUT when AuxOutSrc = 11 (unlock indicator).
- Switching AuxOutSrc[1:0] to or from 01 (CLK_IN) and to or from 11 (unlock indicator) (Transitions between AuxOutSrc[1:0] = [00,10] will not produce a glitch).

When any of these exceptions occur, a partial clock period on the output may result.

5.8.2 PLL Unlock Conditions

Certain changes to the clock inputs and mode pins can cause the PLL to lose lock which will affect the presence of a clock signal on CLK_OUT. The following outlines which conditions cause the PLL to go unlocked:

- Any change in the state of the M1 and M0 pins will cause the PLL to temporarily lose lock as the new setting takes affect.
- Changes made to the state of the M2 when the M2Config[2:0] global parameter is set to 011, 100, 101, or 110 can cause the PLL to temporarily lose lock as the new setting takes affect.
- Discontinuities on the Frequency Reference Clock, CLK_IN, except when the Clock Skipping feature is enabled and the requirements of Clock Skipping are satisfied (see [“CLK_IN Skipping Mode” on page 10](#)).
- Gradual changes in CLK_IN frequency greater than $\pm 30\%$ from the starting frequency.
- Step changes in CLK_IN frequency.

6. PARAMETER DESCRIPTIONS

As mentioned in [Section 5.1 on page 10](#), there are two different kinds of parameter configuration sets, Modal and Global. These configuration sets, shown in [Figure 14](#), can be programmed in the field using the CDK2000 or pre-programmed at the factory. Please see [“Programming Information” on page 25](#) for more details.

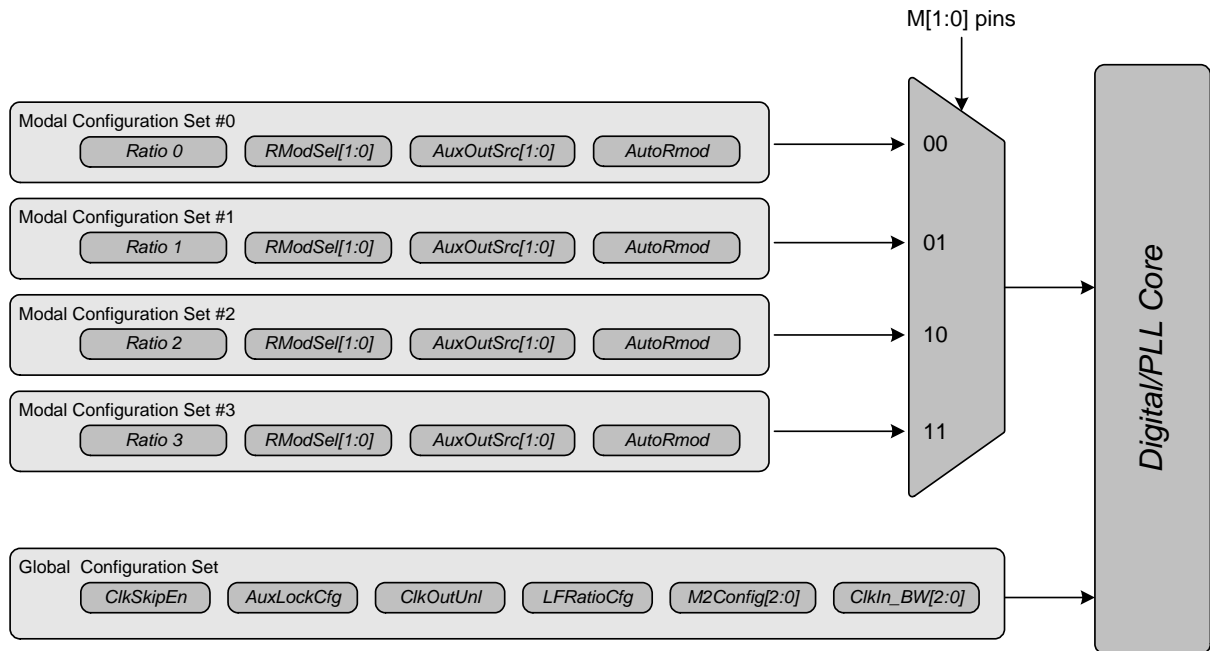

Figure 14. Parameter Configuration Sets

6.1 Modal Configuration Sets

There are four instances of each of these configuration parameters. Selection between the four stored sets is made using the M[1:0] pins.

6.1.1 R-Mod Selection (RModSel[1:0])

Selects the R-Mod value, which is used as a factor in determining the PLL's Fractional N.

RModSel[1:0]	R-Mod Selection
00	Right-shift R-value by 1 ($\div 2$).
01	Right-shift R-value by 2 ($\div 4$).
10	Right-shift R-value by 3 ($\div 8$).
11	Right-shift R-value by 4 ($\div 16$).
Application:	“Manual Ratio Modifier (R-Mod)” on page 14

Note: This parameter does not take affect unless M2 pin is high and the *M2Config[2:0]* global parameter is set to '011'.

6.1.2 Auxiliary Output Source Selection (*AuxOutSrc[1:0]*)

Selects the source of the AUX_OUT signal.

AuxOutSrc[1:0]	Auxiliary Output Source
00	Reserved.
01	CLK_IN.
10	CLK_OUT.
11	PLL Lock Status Indicator.
Application:	"Auxiliary Output" on page 17

Note: When set to 11, the *AuxLockCfg* global parameter sets the polarity and driver type ("[AUX PLL Lock Output Configuration \(AuxLockCfg\)](#)" on page 22).

6.1.3 Auto R-Modifier Enable (*AutoRMod*)

Controls the automatic ratio modifier function.

AutoRMod	Automatic R-Mod State
0	Disabled.
1	Enabled.
Application:	"Automatic Ratio Modifier (Auto R-Mod)" on page 14

6.2 Ratio 0 - 3

The four 32-bit User Defined Ratios are stored in the CS2300's one time programmable memory. See "[Output to Input Frequency Ratio Configuration](#)" on page 13 and "[Calculating the User Defined Ratio](#)" on page 24 for more details.

6.3 Global Configuration Parameters

6.3.1 Clock Skip Enable (*ClkSkipEn*)

This parameter enables clock skipping mode for the PLL and allows the PLL to maintain lock even when the CLK_IN has missing pulses.

ClkSkipEn	PLL Clock Skipping Mode
0	Disabled.
1	Enabled.
Application:	"CLK_IN Skipping Mode" on page 10

Note: f_{CLK_IN} must be < 80 kHz to use this feature.

6.3.2 AUX PLL Lock Output Configuration (*AuxLockCfg*)

When the AUX_OUT pin is configured as a lock indicator (*AuxOutSrc[1:0]* modal parameter = '11'), this global parameter configures the AUX_OUT driver to either push-pull or open drain. It also determines the polarity of the lock signal. If AUX_OUT is configured as a clock output, the state of this parameter is disregarded.

<i>AuxLockCfg</i>	AUX_OUT Driver Configuration
0	Push-Pull, Active High (output 'high' for unlocked condition, 'low' for locked condition).
1	Open Drain, Active Low (output 'low' for unlocked condition, high-Z for locked condition).
Application:	"Auxiliary Output" on page 17

Note: AUX_OUT is an **unlock** indicator, signalling an error condition when the PLL is unlocked. Therefore, the pin polarity is defined relative to the **unlock** condition.

6.3.3 Enable PLL Clock Output on Unlock (*ClkOutUnl*)

Defines the state of the PLL output during the PLL unlock condition.

<i>ClkOutUnl</i>	Clock Output Enable Status
0	Clock outputs are driven 'low' when PLL is unlocked.
1	Clock outputs are always enabled (results in unpredictable output when PLL is unlocked).
Application:	"PLL Clock Output" on page 16

6.3.4 Low-Frequency Ratio Configuration (*LFRatioCfg*)

Determines how to interpret the currently indexed 32-bit User Defined Ratio .

<i>LFRatioCfg</i>	Ratio Bit Encoding Interpretation
0	20.12 - High Multiplier.
1	12.20 - High Accuracy.
Application:	"User Defined Ratio (<i>R_{UD}</i>)" on page 13

6.3.5 M2 Pin Configuration (*M2Config[2:0]*)

Controls which special function is mapped to the M2 pin.

<i>M2Config[2:0]</i>	M2 pin function
000	Disable CLK_OUT pin.
001	Disable AUX_OUT pin.
010	Disable CLK_OUT and AUX_OUT.
011	<i>RModSel[1:0]</i> Modal Parameter Enable.
100	Reserved.
101	<i>AutoRMod</i> Modal Parameter Override.
110	Reserved.
111	Force <i>AuxOutSrc[1:0]</i> = 10 (PLL Clock Out).
Application:	"M2 Mode Pin Functionality" on page 18

6.3.6 Clock Input Bandwidth (ClkIn_BW[2:0])

Sets the minimum loop bandwidth when locked to CLK_IN.

ClkIn_BW[2:0]	Minimum Loop Bandwidth
000	1 Hz
001	2 Hz
010	4 Hz
011	8 Hz
100	16 Hz
101	32 Hz
110	64 Hz
111	128 Hz
Application:	"Adjusting the Minimum Loop Bandwidth for CLK_IN" on page 12

7. CALCULATING THE USER DEFINED RATIO

Note: The software for use with the evaluation kit has built in tools to aid in calculating and converting the User Defined Ratio. This section is for those who would like to know more about how the User Defined Ratio is calculated and stored.

Most calculators do not interpret the fixed point binary representation which the CS2300-OTP uses to define the output to input clock ratio (see [Section 5.4.1 on page 13](#)); However, with a simple conversion we can use these tools to generate a binary or hex value for $Ratio_{0-3}$ to be stored in one time programmable memory. Please see [“Programming Information” on page 25](#) for more details on programming.

7.1 High Resolution 12.20 Format

To calculate the User Defined Ratio (R_{UD}) to store in the register(s), divide the desired output clock frequency by the given input clock (CLK_IN). Then multiply the desired ratio by the scaling factor of 2^{20} to get the scaled decimal representation; then use the decimal to binary/hex conversion function on a calculator and write to the register. A few examples have been provided in [Table 5](#).

Desired Output to Input Clock Ratio (output clock/input clock)	Scaled Decimal Representation = (output clock/input clock) • 2^{20}	Hex Representation of Binary R_{UD}
12.288 MHz/10 MHz=1.2288	1288490	00 13 A9 2A
11.2896 MHz/44.1 kHz=256	268435456	10 00 00 00

Table 5. Example 12.20 R-Values

7.2 High Multiplication 20.12 Format

To calculate the User Defined Ratio (R_{UD}) to store in the register(s), divide the desired output clock frequency by the given input clock (CLK_IN). Then multiply the desired ratio by the scaling factor of 2^{12} to get the scaled decimal representation; then use the decimal to binary/hex conversion function on a calculator and write to the register. A few examples have been provided in [Table 6](#).

Desired Output to Input Clock Ratio (output clock/input clock)	Scaled Decimal Representation = (output clock/input clock) • 2^{12}	Hex Representation of Binary R_{UD}
12.288 MHz/60 Hz=204,800	838860800	32 00 00 00
11.2896 MHz/59.97 Hz =188254.127...	771088904	2D F5 E2 08

Table 6. Example 20.12 R-Values

8. PROGRAMMING INFORMATION

Field programming of the CS2300-OTP is achieved using the hardware and software tools included with the CDK2000. The software tools can be downloaded from www.cirrus.com for evaluation prior to ordering a CDK. The CDK2000 is designed with built-in features to ease the process of programming small quantities of devices for prototype and small production builds. In addition to its field programming capabilities, the CDK2000 can also be used for the complete evaluation of programmed CS2300-OTP devices.

The CS2300-OTP can also be factory programmed for large quantity orders. When ordering factory programmed devices, the CDK should first be used to program and evaluate the desired configuration. When evaluation is complete, the CS2000 Configuration Wizard is used to generate a file containing all device configuration information; this file is conveyed to Cirrus Logic as a complete specification for the factory programming configuration. Please contact your local Cirrus Logic sales representative for more information regarding factory programmed parts.

See the CDK2000 datasheet, available at www.cirrus.com, for detailed information on the use of the CDK2000 programming and evaluation tools.

Below is a form which represents the information required for programming a device (noted in gray). The “[Parameter Descriptions](#)” section beginning on page 20 describes the functions of each parameter. This form may be used either for personal notation for device configuration or it can be filled out and given to a Cirrus representative in conjunction with the programming file from the CDK2000 as an additional check. The User Defined Ratio may be filled out in decimal or it may be entered as hex as outlined in “[Calculating the User Defined Ratio](#)” on page 24. For all other parameters mark a ‘0’ or ‘1’ below the parameter name.

OTP Modal and Global Configuration Parameters Form						
Modal Configuration Set #0						
Ratio 0 (dec)						
Ratio 0 (hex)	_____ : _____ : _____ : _____					
	RModSel1	RModSel0	AuxOutSrc1	AuxOutSrc0	AutoRMod	
Modal Configuration Set #1						
Ratio 0 (dec)						
Ratio 0 (hex)	_____ : _____ : _____ : _____					
	RModSel1	RModSel0	AuxOutSrc1	AuxOutSrc0	AutoRMod	
Modal Configuration Set #2						
Ratio 0 (dec)						
Ratio 0 (hex)	_____ : _____ : _____ : _____					
	RModSel1	RModSel0	AuxOutSrc1	AuxOutSrc0	AutoRMod	
Modal Configuration Set #3						
Ratio 0 (dec)						
Ratio 0 (hex)	_____ : _____ : _____ : _____					
	RModSel1	RModSel0	AuxOutSrc1	AuxOutSrc0	AutoRMod	
Global Configuration Set						
ClkSkipEn	AuxLockCfg	ClkOutUnl	LFRatioCfg	M2Cfg2	M2Cfg1	M2Cfg0
ClkIn_BW2	ClkIn_BW1	ClkIn_BW0				

9. PACKAGE DIMENSIONS

10L MSOP (3 mm BODY) PACKAGE DRAWING (Note 1)

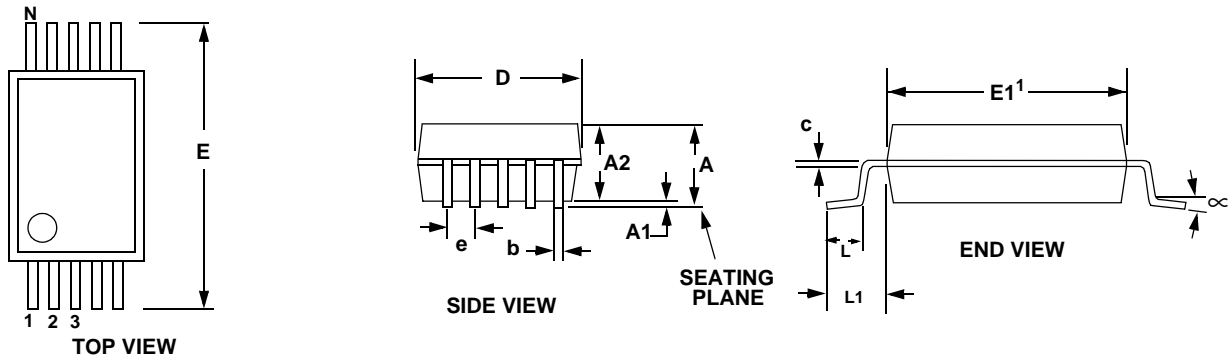

DIM	INCHES			MILLIMETERS			NOTE
	MIN	NOM	MAX	MIN	NOM	MAX	
A	--	--	0.0433	--	--	1.10	
A1	0	--	0.0059	0	--	0.15	
A2	0.0295	--	0.0374	0.75	--	0.95	
b	0.0059	--	0.0118	0.15	--	0.30	4, 5
c	0.0031	--	0.0091	0.08	--	0.23	
D	--	0.1181 BSC	--	--	3.00 BSC	--	2
E	--	0.1929 BSC	--	--	4.90 BSC	--	
E1	--	0.1181 BSC	--	--	3.00 BSC	--	3
e	--	0.0197 BSC	--	--	0.50 BSC	--	
L	0.0157	0.0236	0.0315	0.40	0.60	0.80	
L1	--	0.0374 REF	--	--	0.95 REF	--	

- Notes:**
- Reference document: JEDEC MO-187
 - D does not include mold flash or protrusions which is 0.15 mm max. per side.
 - E1 does not include inter-lead flash or protrusions which is 0.15 mm max per side.
 - Dimension b does not include a total allowable dambar protrusion of 0.08 mm max.
 - Exceptions to JEDEC dimension.

THERMAL CHARACTERISTICS

Parameter		Symbol	Min	Typ	Max	Units
Junction to Ambient Thermal Impedance	JEDEC 2-Layer	θ_{JA}	-	170	-	°C/W
	JEDEC 4-Layer	θ_{JA}	-	100	-	°C/W

10. ORDERING INFORMATION

The CS2300-OTP is ordered as an un-programmed device. The CS2300-OTP can also be factory programmed for large quantity orders. Please see “Programming Information” on page 25 for more details.

Product	Description	Package	Pb-Free	Grade	Temp Range	Container	Order#
CS2300-OTP	Clocking Device	10L-MSOP	Yes	Commercial	-10° to +70°C	Rail	CS2300P-CZZ
CS2300-OTP	Clocking Device	10L-MSOP	Yes		-10° to +70°C	Tape and Reel	CS2300P-CZZR
CDK2000	Evaluation Platform	-	Yes	-	-	-	CDK-2000-LCO

11. REVISION HISTORY

Release	Changes
A1	Initial Release

Contacting Cirrus Logic Support

For all product questions and inquiries, contact a Cirrus Logic Sales Representative. To find one nearest you, go to www.cirrus.com.

IMPORTANT NOTICE

“Advance” product information describes products that are in development and subject to development changes.

Cirrus Logic, Inc. and its subsidiaries (“Cirrus”) believe that the information contained in this document is accurate and reliable. However, the information is subject to change without notice and is provided “AS IS” without warranty of any kind (express or implied). Customers are advised to obtain the latest version of relevant information to verify, before placing orders, that information being relied on is current and complete. All products are sold subject to the terms and conditions of sale supplied at the time of order acknowledgment, including those pertaining to warranty, indemnification, and limitation of liability. No responsibility is assumed by Cirrus for the use of this information, including use of this information as the basis for manufacture or sale of any items, or for infringement of patents or other rights of third parties. This document is the property of Cirrus and by furnishing this information, Cirrus grants no license, express or implied under any patents, mask work rights, copyrights, trademarks, trade secrets or other intellectual property rights. Cirrus owns the copyrights associated with the information contained herein and gives consent for copies to be made of the information only for use within your organization with respect to Cirrus integrated circuits or other products of Cirrus. This consent does not extend to other copying such as copying for general distribution, advertising or promotional purposes, or for creating any work for resale.

CERTAIN APPLICATIONS USING SEMICONDUCTOR PRODUCTS MAY INVOLVE POTENTIAL RISKS OF DEATH, PERSONAL INJURY, OR SEVERE PROPERTY OR ENVIRONMENTAL DAMAGE (“CRITICAL APPLICATIONS”). CIRRUS PRODUCTS ARE NOT DESIGNED, AUTHORIZED OR WARRANTED FOR USE IN PRODUCTS SURGICALLY IMPLANTED INTO THE BODY, AUTOMOTIVE SAFETY OR SECURITY DEVICES, LIFE SUPPORT PRODUCTS OR OTHER CRITICAL APPLICATIONS. INCLUSION OF CIRRUS PRODUCTS IN SUCH APPLICATIONS IS UNDERSTOOD TO BE FULLY AT THE CUSTOMER’S RISK AND CIRRUS DISCLAIMS AND MAKES NO WARRANTY, EXPRESS, STATUTORY OR IMPLIED, INCLUDING THE IMPLIED WARRANTIES OF MERCHANTABILITY AND FITNESS FOR PARTICULAR PURPOSE, WITH REGARD TO ANY CIRRUS PRODUCT THAT IS USED IN SUCH A MANNER. IF THE CUSTOMER OR CUSTOMER’S CUSTOMER USES OR PERMITS THE USE OF CIRRUS PRODUCTS IN CRITICAL APPLICATIONS, CUSTOMER AGREES, BY SUCH USE, TO FULLY INDEMNIFY CIRRUS, ITS OFFICERS, DIRECTORS, EMPLOYEES, DISTRIBUTORS AND OTHER AGENTS FROM ANY AND ALL LIABILITY, INCLUDING ATTORNEYS’ FEES AND COSTS, THAT MAY RESULT FROM OR ARISE IN CONNECTION WITH THESE USES.

Cirrus Logic, Cirrus, and the Cirrus Logic logo designs are trademarks of Cirrus Logic, Inc. All other brand and product names in this document may be trademarks or service marks of their respective owners.

X-ON Electronics

Largest Supplier of Electrical and Electronic Components

Click to view similar products for [Clock Synthesizer/Jitter Cleaner](#) category:

Click to view products by [Cirrus Logic](#) manufacturer:

Other Similar products are found below :

[MPC9230EIR2](#) [PL902166USY](#) [954204CGLF](#) [9LPRS485DGLF](#) [PL902167USY](#) [8V19N490ABDGI](#) [LMK04821NKDT](#) [CDCE937QPWRQ1](#)
[PI6CX201ALE](#) [9LPRS355BGLF](#) [CDCEL913IPWRQ1](#) [ABMJB-903-101UMG-T5](#) [ABMJB-903-150UMG-T5](#) [ABMJB-903-151UMG-T5](#)
[AD9542BCPZ](#) [AD9578BCPZ](#) [9FG104EFILF](#) [9FG104EFLF](#) [308RILF](#) [840001BGI-25LF](#) [843004AGLF](#) [843801AGI-24LF](#) [844004BGI-01LF](#)
[844S42BKILF](#) [8A34044C-000NLG](#) [954226AGLF](#) [9FG108EFLF](#) [9LPR363EGLF](#) [9LPRS355BKLF](#) [9LPRS365BGLF](#) [GS4915-INE3](#)
[9DB306BLLF](#) [ABMJB-902-155USY-T5](#) [ABMJB-902-156USY-T5](#) [ABMJB-902-Q76USY-T5](#) [ABMJB-902-Q82USY-T5](#) [ABMJB-902-](#)
[104USY-T5](#) [ABMJB-902-153USY-T5](#) [ABMJB-902-154USY-T5](#) [ABMJB-902-Q42USY-T5](#) [ABMJB-902-Q57USY-T5](#) [ABMJB-902-](#)
[Q74USY-T5](#) [ABMJB-902-Q78USY-T5](#) [LTC6951IUHF-1#PBF](#) [650GI-44LF](#) [8430252CGI-45LF](#) [8432DYI-101LF](#) [84329BYLF](#) [8432DY-](#)
[101LF](#) [8432BY-51LF](#)