

24-bit, 192kHz 6-Channel CODEC with Volume Control

DESCRIPTION

The WM8772 is a multi-channel audio CODEC ideal for DVD and surround sound processing applications for home hi-fi, automotive and other audio visual equipment.

A stereo 24-bit multi-bit sigma delta ADC is used. Digital audio output word lengths from 16-32 bits and sampling rates from 32kHz to 96kHz are supported.

Three stereo 24-bit multi-bit sigma delta DACs are used with oversampling digital interpolation filters. Digital audio input word lengths from 16-32 bits and sampling rates from 8kHz to 192kHz are supported. Each DAC channel has independent digital volume and mute control.

The audio data interface supports I²S, left justified, right justified and DSP digital audio formats.

The device is controlled via a 3 wire serial interface. The interface provides access to all features including channel selection, volume controls, mutes, de-emphasis and power management facilities.

The device is available in a 28 lead SSOP.

The device is available over a functional temperature range of -40°C to +85°C

FEATURES

- Audio Performance
 - 100dB SNR ('A' weighted @ 48kHz) DAC
 - 98dB SNR ('A' weighted @ 48kHz) ADC
- DAC Sampling Frequency: 8kHz – 192kHz
- ADC Sampling Frequency: 32kHz – 96kHz
- 3-Wire SPI Serial or Hardware Control Interface
- Programmable Audio Data Interface Modes
 - I²S, Left, Right Justified or DSP
 - 16/20/24/32 bit Word Lengths
- Three Independent stereo DAC outputs with independent digital volume controls
- Master or Slave Audio Data Interface
- 3.0V to 5.5V Analogue, 3.0V to 3.6V Digital supply Operation
- 28 lead SSOP Package

APPLICATIONS

- DVD Players
- Surround Sound AV Processors and Hi-Fi systems
- Automotive Audio

BLOCK DIAGRAM

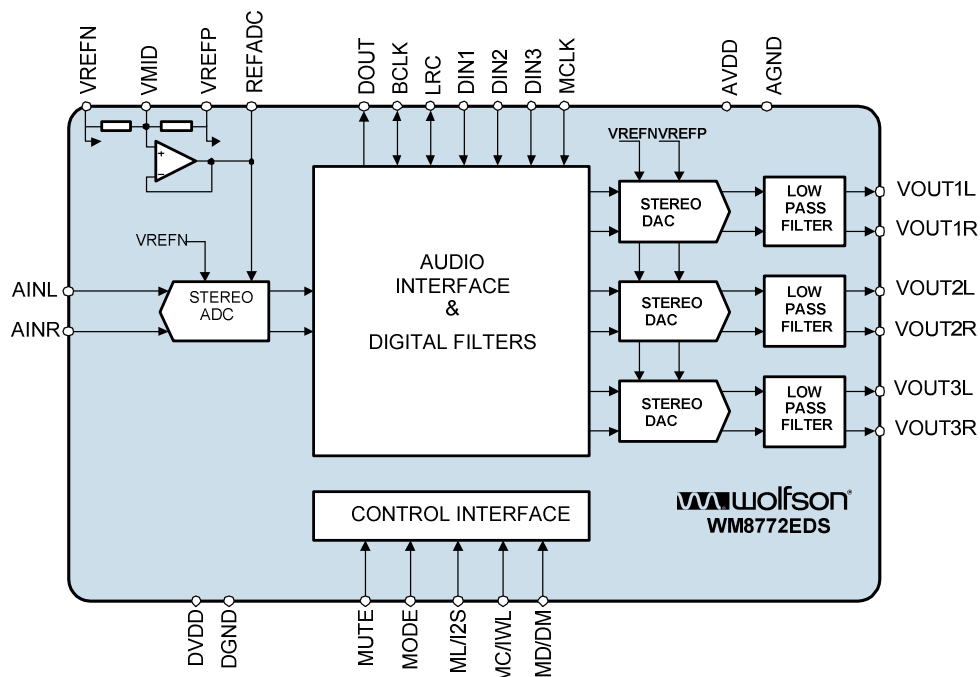
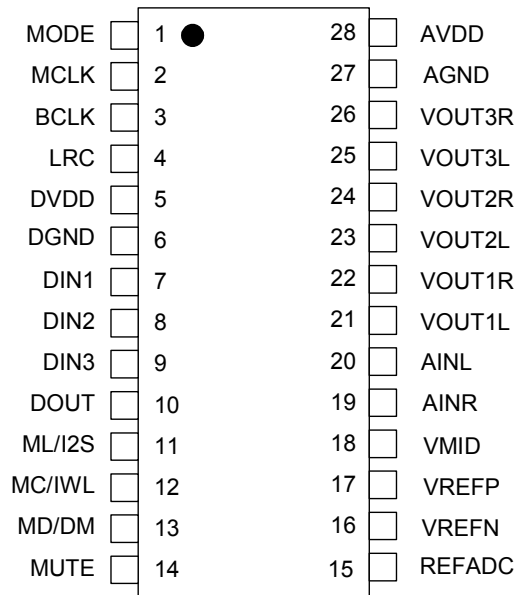

TABLE OF CONTENTS

DESCRIPTION	1
FEATURES.....	1
APPLICATIONS	1
BLOCK DIAGRAM	1
TABLE OF CONTENTS	2
PIN CONFIGURATION.....	3
ORDERING INFORMATION	3
PIN DESCRIPTION	4
ABSOLUTE MAXIMUM RATINGS.....	5
RECOMMENDED OPERATING CONDITIONS	6
ELECTRICAL CHARACTERISTICS	6
TERMINOLOGY	8
DIGITAL FILTER CHARACTERISTICS	9
DAC FILTER RESPONSES.....	9
ADC FILTER RESPONSES.....	10
ADC HIGH PASS FILTER	10
DIGITAL DE-EMPHASIS CHARACTERISTICS.....	10
MASTER CLOCK TIMING.....	12
DIGITAL AUDIO INTERFACE – MASTER MODE.....	12
DIGITAL AUDIO INTERFACE – SLAVE MODE	14
MPU INTERFACE TIMING	15
DEVICE DESCRIPTION.....	16
INTRODUCTION.....	16
AUDIO DATA SAMPLING RATES.....	16
HARDWARE CONTROL MODES	17
DIGITAL AUDIO INTERFACE	19
POWERDOWN MODES	24
ZERO DETECT	24
SOFTWARE CONTROL INTERFACE OPERATION.....	25
REGISTER MAP.....	26
CONTROL INTERFACE REGISTERS	27
APPLICATIONS INFORMATION	35
RECOMMENDED EXTERNAL COMPONENTS.....	35
SUGGESTED ANALOGUE LOW PASS POST DAC FILTERS	36
PACKAGE DIMENSIONS	38
IMPORTANT NOTICE	39
ADDRESS:.....	39

PIN CONFIGURATION



ORDERING INFORMATION

DEVICE	TEMPERATURE RANGE	PACKAGE	MOISTURE SENSITIVITY LEVEL	PEAK SOLDERING TEMPERATURE
WM8772SEDS/V	-40 to +85°C	28-lead SSOP (Pb free)	MSL3	260°C
WM8772SEDS/RV	-40 to +85°C	28-lead SSOP (Pb free, tape and reel)	MSL3	260°C

Note:

1. Reel quantity = 2,000

PIN DESCRIPTION

PIN	NAME	TYPE	DESCRIPTION
1	MODE	Digital input	Control format selection 0 = Software control 1 = Hardware control
2	MCLK	Digital input	Master clock; 256, 384, 512 or 768fs (fs = word clock frequency) (combined ADCMCLK and DACMCLK)
3	BCLK	Digital input/output	Audio interface bit clock (combined ADCBCLK and DACBCLK)
4	LRC	Digital input/output	Audio left/right word clock (combined ADCLRC and DACLRC)
5	DVDD	Supply	Digital positive supply
6	DGND	Supply	Digital negative supply
7	DIN1	Digital input	DAC channel 1 data input
8	DIN2	Digital input	DAC channel 2 data input
9	DIN3	Digital input	DAC channel 3 data input
10	DOUT	Digital output	ADC data output
11	ML/I2S	Digital input	Software Mode: Serial interface Latch signal Hardware Mode: Input Audio Data Format
12	MC/IWL	Digital input	Software Mode: Serial control interface clock Hardware Mode: Audio data input word length
13	MD/DM	Digital input	Software Mode: Serial interface data Hardware Mode: De-emphasis selection
14	MUTE	Digital input/output	DAC Zero Flag output or DAC mute input
15	REFADC	Analogue output	ADC reference buffer decoupling pin; 10uF external decoupling
16	VREFN	Supply	ADC and DAC negative supply
17	VREFP	Supply	DAC positive reference supply
18	VMID	Analogue output	Midrail divider decoupling pin; 10uF external decoupling
19	AINR	Analogue input	ADC right input
20	AINL	Analogue input	ADC left input
21	VOUT1L	Analogue output	DAC channel 1 left output
22	VOUT1R	Analogue output	DAC channel 1 right output
23	VOUT2L	Analogue output	DAC channel 2 left output
24	VOUT2R	Analogue output	DAC channel 2 right output
25	VOUT3L	Analogue output	DAC channel 3 left output
26	VOUT3R	Analogue output	DAC channel 3 right output
27	AGND	Supply	Analogue negative supply and substrate connection
28	AVDD	Supply	Analogue positive supply

Note: Digital input pins have Schmitt trigger input buffers.

ABSOLUTE MAXIMUM RATINGS

Absolute Maximum Ratings are stress ratings only. Permanent damage to the device may be caused by continuously operating at or beyond these limits. Device functional operating limits and guaranteed performance specifications are given under Electrical Characteristics at the test conditions specified.



ESD Sensitive Device. This device is manufactured on a CMOS process. It is therefore generically susceptible to damage from excessive static voltages. Proper ESD precautions must be taken during handling and storage of this device.

Wolfson tests its package types according to IPC/JEDEC J-STD-020B for Moisture Sensitivity to determine acceptable storage conditions prior to surface mount assembly. These levels are:

MSL1 = unlimited floor life at <math><30^{\circ}\text{C}</math> / 85% Relative Humidity. Not normally stored in moisture barrier bag.

MSL2 = out of bag storage for 1 year at <math><30^{\circ}\text{C}</math> / 60% Relative Humidity. Supplied in moisture barrier bag.

MSL3 = out of bag storage for 168 hours at <math><30^{\circ}\text{C}</math> / 60% Relative Humidity. Supplied in moisture barrier bag.

The Moisture Sensitivity Level for each package type is specified in Ordering Information.

CONDITION	MIN	MAX
Digital supply voltage	-0.3V	+5V
Analogue supply voltage	-0.3V	+7V
Voltage range digital inputs ¹	DGND -0.3V	DVDD +0.3V
Voltage range analogue inputs ¹	AGND -0.3V	AVDD +0.3V
Master Clock Frequency		37MHz
Operating temperature range, - T_A	-40°C	+85°C
Storage temperature after soldering	-65°C	+150°C
Package body temperature (soldering 10 seconds)		Refer to Ordering Information, p3
Package body temperature (soldering 2 minutes)		+183°C

Notes:

- Analogue and digital grounds must always be within 0.3V of each other.

RECOMMENDED OPERATING CONDITIONS

PARAMETER	SYMBOL	TEST CONDITIONS	MIN	TYP	MAX	UNIT
Digital supply range	DVDD		3.0		3.6	V
Analogue supply range	AVDD, VREFP		3.0		5.5	V
Ground	AGND, VREFN, DGND			0		V
Difference DGND to AGND			-0.3	0	+0.3	V

Note: Digital supply DVDD must never be more than 0.3V greater than AVDD.

ELECTRICAL CHARACTERISTICS

Test Conditions

AVDD, VREFP = 5V, DVDD = 3.3V, AGND, VREFN = 0V, DGND = 0V, $T_A = +25^\circ\text{C}$, $f_s = 48\text{kHz}$, MCLK = 256fs, ADC/DAC in Slave Mode unless otherwise stated.

PARAMETER	SYMBOL	TEST CONDITIONS	MIN	TYP	MAX	UNIT
DAC Output (Load = 10kΩ, 50pF)						
0dBFS Full scale output voltage				1.0 x VREFP/5		V _{rms}
DAC Performance (+25°C)						
SNR (Note 1,2,4)		A-weighted, @ $f_s = 48\text{kHz}$	95	100		dB
SNR (Note 1,2,4)		A-weighted @ $f_s = 96\text{kHz}$		99		dB
SNR (Note 1,2,4)		A-weighted @ $f_s = 192\text{kHz}$		98		dB
SNR (Note 1,2,4)		A-weighted @ $f_s = 48\text{kHz}$, AVDD = 3.3V		96		dB
SNR (Note 1,2,4)		A-weighted @ $f_s = 96\text{kHz}$, AVDD = 3.3V		96		dB
Dynamic Range (Note 2,4)	DNR	A-weighted, -60dB full scale input	90	100		dB
Total Harmonic Distortion (THD)		1kHz, 0dB.Fs		-90	-80	dB
Mute Attenuation		1kHz Input, 0dB gain		100		dB
DAC channel separation				100		dB
Power Supply Rejection Ratio	PSRR	1kHz 100mV _{p-p}		50		dB
		20Hz to 20kHz 100mV _{p-p}		45		dB

Test Conditions

AVDD, VREFP = 5V, DVDD = 3.3V, AGND, VREFN = 0V, DGND = 0V, T_A = +25°C, fs = 48kHz, MCLK = 256fs, ADC/DAC in Slave Mode unless otherwise stated.

PARAMETER	SYMBOL	TEST CONDITIONS	MIN	TYP	MAX	UNIT
ADC Performance (+25°C)						
Input Signal Level (0dB)				2.0 x REFADC/5		V _{rms}
Input resistance				20		kΩ
Input capacitance				10		pF
SNR (Note 1,2,4)		A-weighted, 0dB gain @ fs = 48kHz	80	98		dB
SNR (Note 1,2,4)		A-weighted, 0dB gain @ fs = 96kHz 64 x OSR		98		dB
SNR (Note 1,2,4)		A-weighted, 0dB gain @ fs = 48kHz, AVDD = 3.3V		93		dB
SNR (Note 1,2,4)		A-weighted, 0dB gain @ fs = 96kHz, AVDD = 3.3V 64 x OSR		93		dB
Total Harmonic Distortion (THD)		1kHz, -1dBFS		-81		dB
Dynamic Range	DNR	-60dBFS		-98		dB
ADC Channel Separation		1kHz Input		90		dB
Mute Attenuation		1kHz Input, 0dB gain		90		dB
Power Supply Rejection Ratio	PSRR	1kHz 100mVpp		50		dB
		20Hz to 20kHz 100mVpp		45		dB
Digital Logic Levels (CMOS Levels)						
Input LOW level	V _{IL}				0.3 x DVDD	V
Input HIGH level	V _{IH}		0.7 x DVDD			V
Input leakage current				±0.2	±1	μA
Input capacitance				5		pF
Output LOW	V _{OL}	I _{OL} =1mA			0.1 x DVDD	V
Output HIGH	V _{OH}	I _{OH} = -1mA	0.9 x DVDD			V
Analogue Reference Levels						
Reference voltage	V _{VMID}		VREFP/2 – 50mV	VREFP/2	VREFP/2 + 50mV	V
Potential divider resistance	R _{VMID}	VREFP to VMID and VMID to VREFN		70		kΩ
Supply Current						
Analogue supply current		AVDD, VREFP = 5V		37		mA
Digital supply current		DVDD = 3.3V		14		mA

Notes:

- Ratio of output level with 1kHz full scale input, to the output level with all zeros into the digital input, measured 'A' weighted.
- All performance measurements done with 20kHz low pass filter, and where noted an A-weight filter. Failure to use such a filter will result in higher THD+N and lower SNR and Dynamic Range readings than are found in the Electrical Characteristics. The low pass filter removes out of band noise; although it is not audible it may affect dynamic specification values.
- VMID decoupled with 10μF and 0.1μF capacitors (smaller values may result in reduced performance).

TERMINOLOGY

1. Signal-to-noise ratio (dB) - SNR is a measure of the difference in level between the full scale output and the output with no signal applied. (No Auto-zero or Automute function is employed in achieving these results).
2. Dynamic range (dB) - DNR is a measure of the difference between the highest and lowest portions of a signal. Normally a THD+N measurement at 60dB below full scale. The measured signal is then corrected by adding the 60dB to it. (e.g. THD+N @ -60dB= -32dB, DR= 92dB).
3. THD+N (dB) - THD+N is a ratio, of the rms values, of (Noise + Distortion)/Signal.
4. Stop band attenuation (dB) - Is the degree to which the frequency spectrum is attenuated (outside audio band).
5. Channel Separation (dB) - Also known as Cross-Talk. This is a measure of the amount one channel is isolated from the other. Normally measured by sending a full scale signal down one channel and measuring the other.
6. Pass-Band Ripple - Any variation of the frequency response in the pass-band region.

DIGITAL FILTER CHARACTERISTICS

PARAMETER	TEST CONDITIONS	MIN	TYP	MAX	UNIT
ADC Filter					
Passband	± 0.01 dB	0		0.4535fs	
	-6dB		0.5fs		
Passband ripple				± 0.01	dB
Stopband		0.5465fs			
Stopband Attenuation	$f > 0.5465fs$	-65			dB
DAC Filter					
Passband	± 0.05 dB			0.444fs	
	-3dB		0.487fs		
Passband ripple				± 0.05	dB
Stopband		0.555fs			
Stopband Attenuation	$f > 0.555fs$	-60			dB

Table 1 Digital Filter Characteristics

DAC FILTER RESPONSES

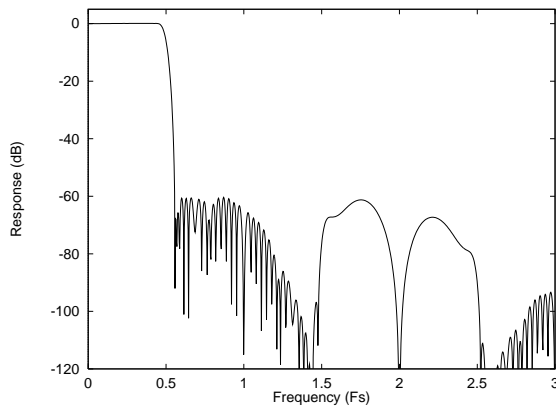

Figure 1 DAC Digital Filter Frequency Response – 44.1, 48 and 96KHz

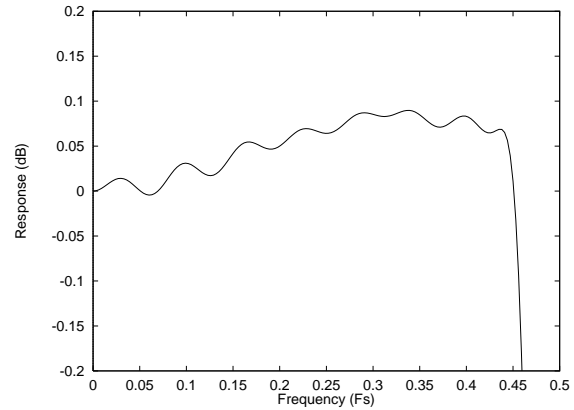

Figure 2 DAC Digital Filter Ripple –44.1, 48 and 96kHz

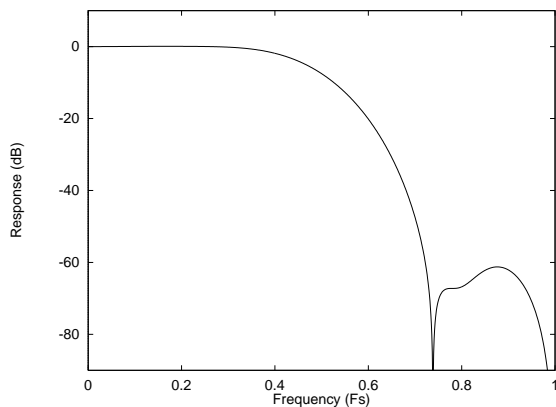

Figure 3 DAC Digital Filter Frequency Response – 192KHz

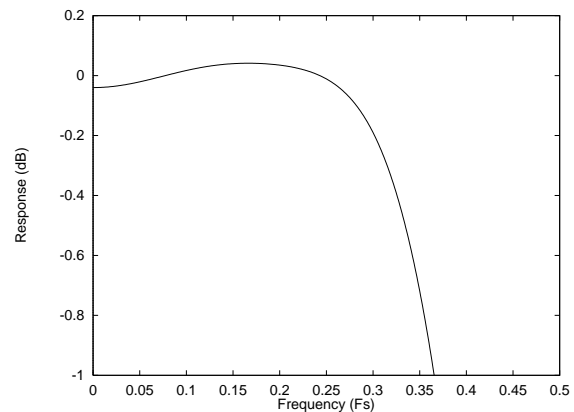

Figure 4 DAC Digital Filter Ripple – 192kHz

ADC FILTER RESPONSES

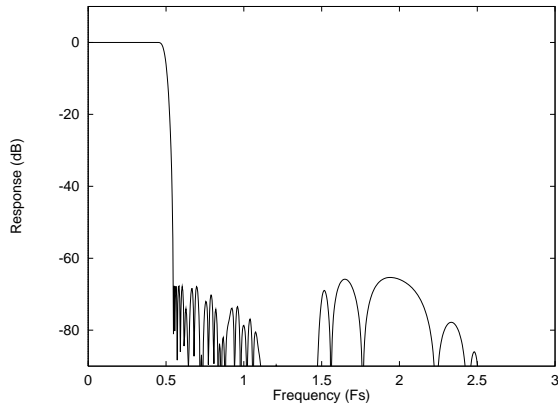

Figure 5 ADC Digital Filter Frequency Response

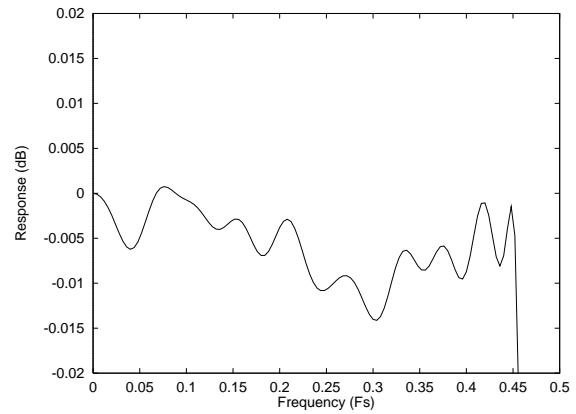

Figure 6 ADC Digital Filter Ripple

ADC HIGH PASS FILTER

The WM8772 has a selectable digital high pass filter to remove DC offsets. The filter response is characterised by the following polynomial.

$$H(z) = \frac{1 - z^{-1}}{1 - 0.9995z^{-1}}$$

DIGITAL DE-EMPHASIS CHARACTERISTICS

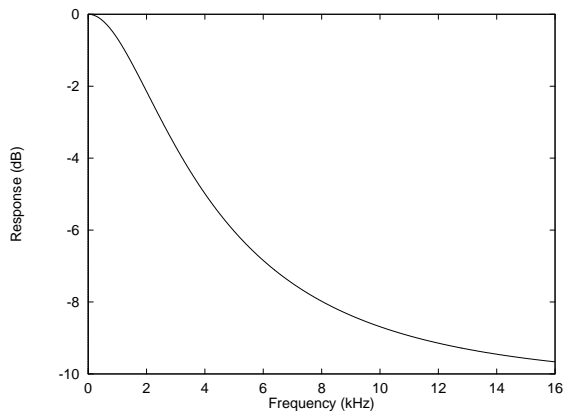

Figure 7 De-Emphasis Frequency Response (32kHz)

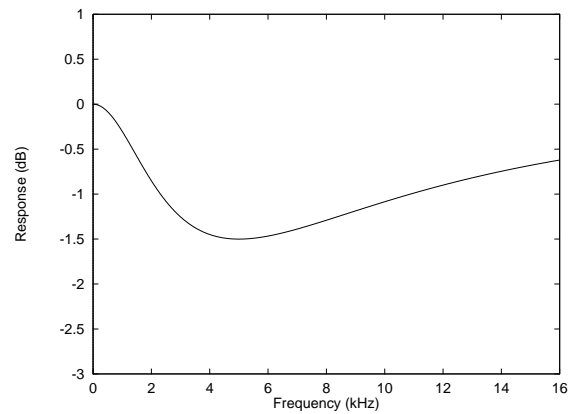

Figure 8 De-Emphasis Error (32kHz)

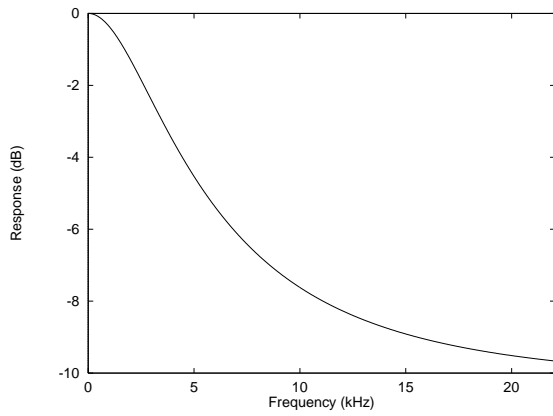

Figure 9 De-Emphasis Frequency Response (44.1KHz)

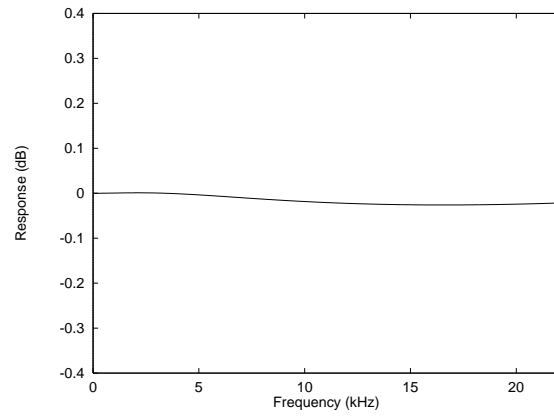

Figure 10 De-Emphasis Error (44.1KHz)

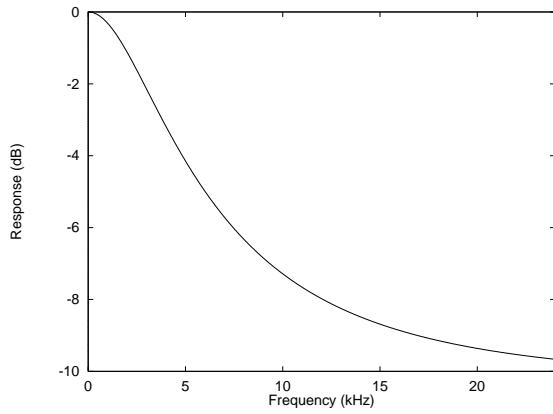

Figure 11 De-Emphasis Frequency Response (48kHz)

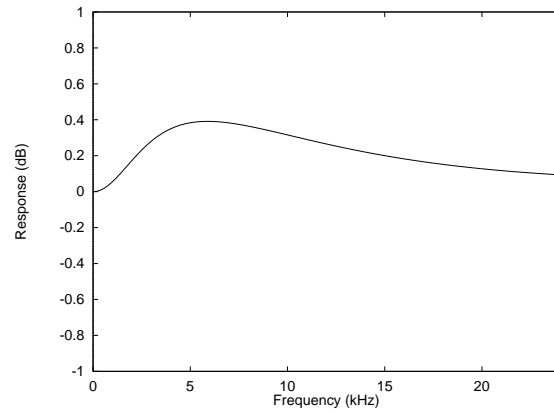

Figure 12 De-Emphasis Error (48kHz)

MASTER CLOCK TIMING

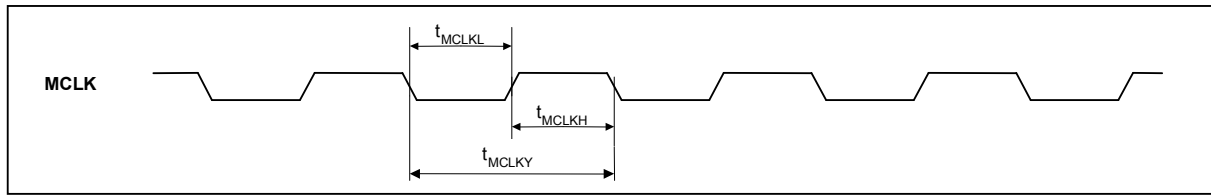

Figure 13 ADC and DAC Master Clock Timing Requirements

Test Conditions

AVDD, VREFP = 5V, DVDD = 3.3V, AGND, VREFN = 0V, AGND, DGND = 0V, T_A = +25°C, fs = 48kHz, DACMCLK and ADCMCLK = 256fs unless otherwise stated.

PARAMETER	SYMBOL	TEST CONDITIONS	MIN	TYP	MAX	UNIT
System Clock Timing Information						
MCLK System clock pulse width high	t_{MCLKH}		11			ns
MCLK System clock pulse width low	t_{MCLKL}		11			ns
MCLK System clock cycle time	t_{MCLKY}		28			ns
MCLK Duty cycle			40:60		60:40	

Table 2 Master Clock Timing Requirements

DIGITAL AUDIO INTERFACE – MASTER MODE

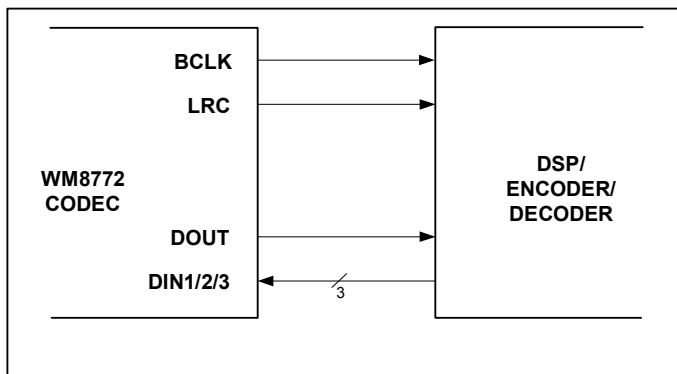

Figure 14 Audio Interface - Master Mode

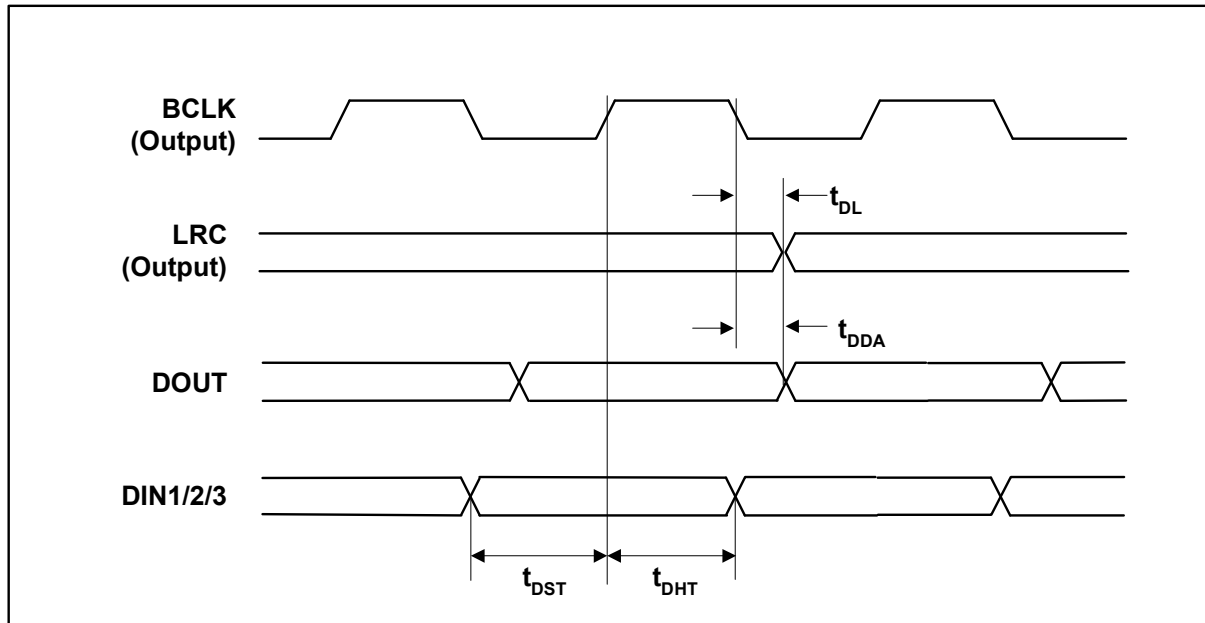

Figure 15 Digital Audio Data Timing – Master Mode

Test Conditions

AVDD, VREFP = 5V, DVDD = 3.3V, AGND, VREFN, DGND = 0V, T_A = +25°C, Master Mode, f_s = 48kHz, MCLK = 256fs unless otherwise stated.

PARAMETER	SYMBOL	TEST CONDITIONS	MIN	TYP	MAX	UNIT
Audio Data Input Timing Information						
LRC propagation delay from BCLK falling edge	t _{DL}		0		10	ns
DOUT propagation delay from BCLK falling edge	t _{DDA}		0		10	ns
DIN1/2/3 setup time to BCLK rising edge	t _{DST}		10			ns
DIN1/2/3 hold time from BCLK rising edge	t _{DHT}		10			ns

Table 3 Digital Audio Data Timing – Master Mode

DIGITAL AUDIO INTERFACE – SLAVE MODE

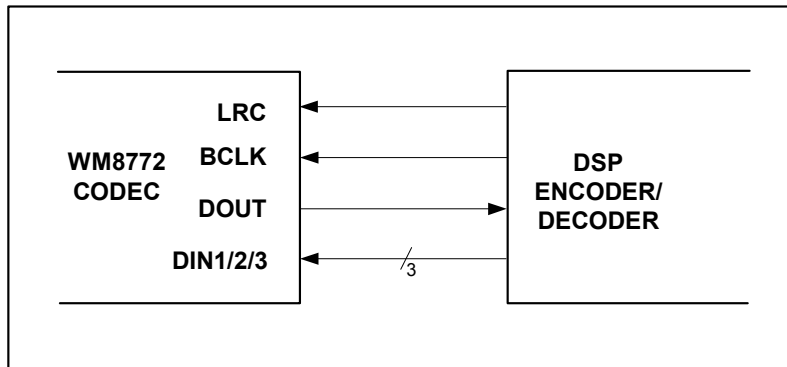

Figure 16 Audio Interface – Slave Mode

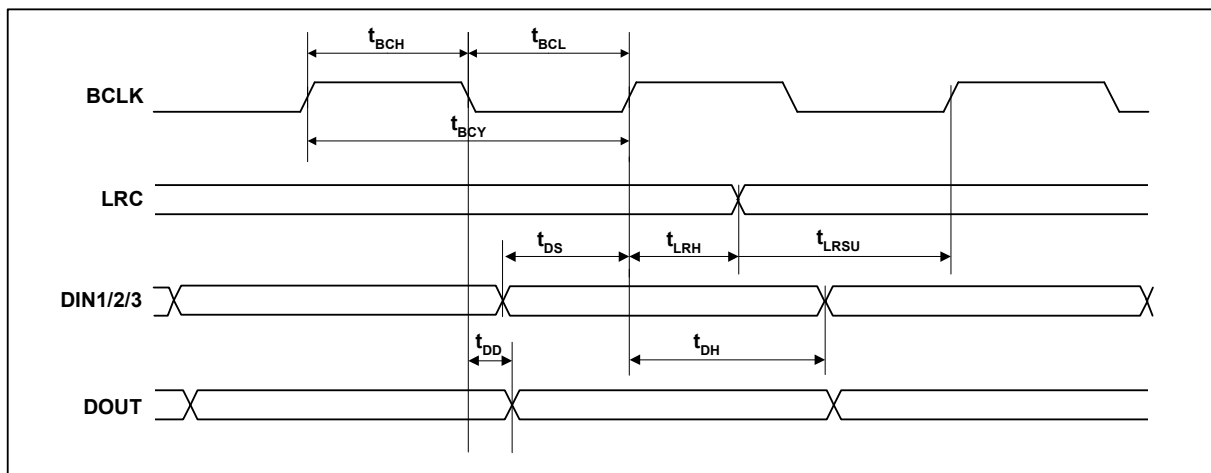

Figure 17 Digital Audio Data Timing – Slave Mode

Test Conditions

AVDD = 5V, DVDD = 3.3V, AGND = 0V, DGND = 0V, T_A = +25°C, Slave Mode, fs = 48kHz, MCLK = 256fs unless otherwise stated.

PARAMETER	SYMBOL	TEST CONDITIONS	MIN	TYP	MAX	UNIT
Audio Data Input Timing Information						
BCLK cycle time	t _{BCY}		50			ns
BCLK pulse width high	t _{BCH}		20			ns
BCLK pulse width low	t _{BCL}		20			ns
LRC set-up time to BCLK rising edge	t _{LRSU}		10			ns
LRC hold time from BCLK rising edge	t _{LRH}		10			ns
DIN1/2/3 set-up time to BCLK rising edge	t _{DS}		10			ns
DIN1/2/3 hold time from BCLK rising edge	t _{DH}		10			ns
DOUT propagation delay from BCLK falling edge	t _{DD}		0		10	ns

Table 4 Digital Audio Data Timing – Slave Mode

MPU INTERFACE TIMING

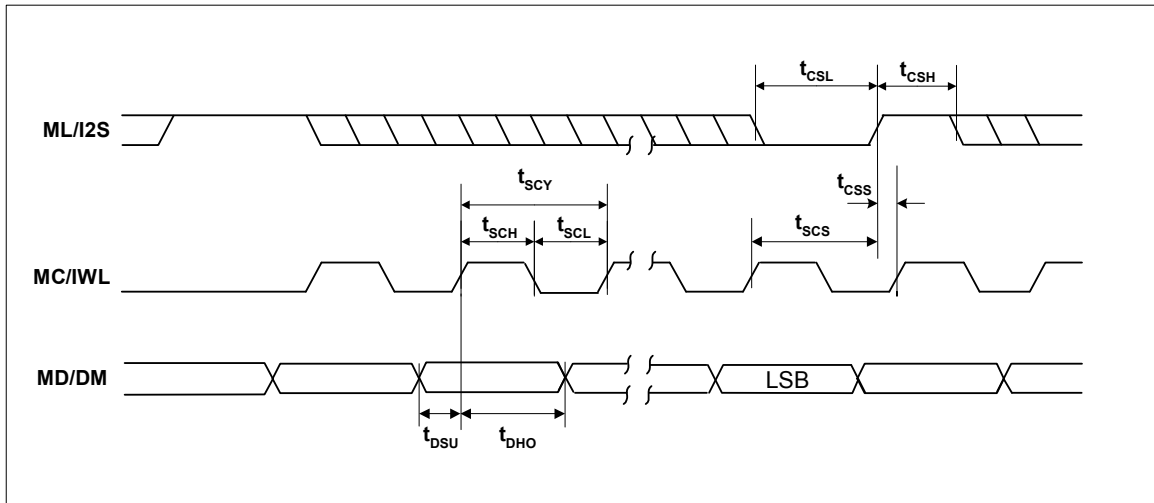

Figure 18 SPI Compatible Control Interface Input Timing

Test Conditions

AVDD = 5V, DVDD = 3.3V, AGND, DGND = 0V, T_A = +25°C, fs = 48kHz, DACMCLK and ADCMCLK = 256fs unless otherwise stated

PARAMETER	SYMBOL	MIN	TYP	MAX	UNIT
MC/IWL rising edge to ML/I2S rising edge	t _{SCS}	60			ns
MC/IWL pulse cycle time	t _{SCY}	80			ns
MC/IWL pulse width low	t _{SCL}	30			ns
MC/IWL pulse width high	t _{SCH}	30			ns
MD/DM to MC/IWL set-up time	t _{DSU}	20			ns
MC/IWL to MD/DM hold time	t _{DHO}	20			ns
ML/I2S pulse width low	t _{CSL}	20			ns
ML/I2S pulse width high	t _{CSH}	20			ns
ML/I2S rising to MC/IWL rising	t _{CSS}	20			ns

Table 5 3-Wire SPI Compatible Control Interface Input Timing Information

DEVICE DESCRIPTION

INTRODUCTION

WM8772 is a complete 6-channel DAC, 2-channel ADC audio CODEC, including digital interpolation and decimation filters, multi-bit sigma delta stereo ADC, and switched capacitor multi-bit sigma delta DACs with digital volume controls on each channel and output smoothing filters.

The device is implemented as three separate stereo DACs and a stereo ADC in a single package and controlled by a single interface.

Each stereo DAC has its own data input DIN1/2/3, the stereo ADC has its own data output DOUT. The word clock LRC, bit clock BCLK and master clock MCLK are shared between them.

The Audio Interface may be configured to operate in either master or slave mode. In Slave mode LRC and BCLK are all inputs. In Master mode LRC and BCLK are all outputs.

Each DAC has its own digital volume control that is adjustable in 0.5dB steps. The digital volume controls may be operated independently. In addition, a zero cross detect circuit is provided for each DAC for the digital volume controls. The digital volume control detects a transition through the zero point before updating the volume. This minimises audible clicks and 'zipper' noise as the gain values change.

Control of internal functionality of the device is by 3-wire serial or pin programmable control interface. The software control interface may be asynchronous to the audio data interface as control data will be re-synchronised to the audio processing internally.

Operation using master clocks of 128fs, 192fs, 256fs, 384fs, 512fs or 768fs is provided for the DAC, for operation of both the ADC and DAC master clocks of 256fs, 384fs, 512fs and 768fs is provided. In Slave mode selection between clock rates is automatically controlled. In master mode, the sample rate is set by control bits RATE. Audio sample rates (fs) from less than 8ks/s up to 192ks/s are allowed for the DAC and from less than 32ks/s up to 96ks/s for the ADC, provided the appropriate master clock is input.

The audio data interface supports right, left and I²S interface formats along with a highly flexible DSP serial port interface.

AUDIO DATA SAMPLING RATES

In a typical digital audio system there is only one central clock source producing a reference clock to which all audio data processing is synchronised. This clock is often referred to as the audio system's Master Clock. The external master system clock can be applied directly through the MCLK input pin with no software configuration necessary. In a system where there are a number of possible sources for the reference clock it is recommended that the clock source with the lowest jitter be used to optimise the performance of the ADC and DAC.

The master clock for WM8772 supports audio sampling rates from 128fs to 768fs, where fs is the audio sampling frequency (LRC) typically 32kHz, 44.1kHz, 48kHz, 96kHz or 192kHz (for DAC operation only). For ADC operation sample rates from 256fs to 768fs are supported. The master clock is used to operate the digital filters and the noise shaping circuits.

In Slave mode the WM8772 has a master clock detection circuit that automatically determines the relationship between the system clock frequency and the sampling rate (to within +/- 32 master clocks). If there is a greater than 32 clocks error the interface defaults to 768fs mode. The master clocks must be synchronised with LRC, although the WM8772 is tolerant of phase variations or jitter on this clock. Table 6 shows the typical master clock frequency inputs for the WM8772.

The signal processing for the WM8772 typically operates at an oversampling rate of 128fs for both ADC and DAC. The exception to this for the DAC is for operation with a 128/192fs system clock, e.g. for 192kHz operation, when the oversampling rate is 64fs. For ADC operation at 96kHz it is recommended that the user set the ADCOSR bit. This changes the ADC signal processing oversample rate to 64fs.

SAMPLING RATE (LRC)	System Clock Frequency (MHz)					
	128fs	192fs	256fs	384fs	512fs	768fs
32kHz	4.096	6.144	8.192	12.288	16.384	24.576
44.1kHz	5.6448	8.467	11.2896	16.9340	22.5792	33.8688
48kHz	6.144	9.216	12.288	18.432	24.576	36.864
96kHz	12.288	18.432	24.576	36.864	Unavailable	Unavailable
192kHz	24.576	36.864	Unavailable	Unavailable	Unavailable	Unavailable

Table 6 System Clock Frequencies Versus Sampling Rate
(ADC does not support 128fs and 192fs)

HARDWARE CONTROL MODES

When the MODE pin is held high, the following hardware modes of operation are available.

Note: When in hardware mode the ADC and DAC will only run in slave mode.

MUTE AND AUTOMUTE OPERATION

In both hardware and software modes, MUTE controls the selection of MUTE directly, and can be used to enable and disable the automute function. This pin becomes an output when left floating and indicates infinite ZERO detect (IZD) has been detected.

	DESCRIPTION
0	Normal Operation
1	Mute DAC channels
Floating	Enable IZD, MUTE becomes an output to indicate when IZD occurs. L=IZD detected, H=IZD not detected.

Table 7 Mute and Automute Control

Figure 19 shows the application and release of MUTE whilst a full amplitude sinusoid is being played at 48kHz sampling rate. When MUTE (lower trace) is asserted, the output (upper trace) begins to decay exponentially from the DC level of the last input sample. The output will decay towards V_{MID} with a time constant of approximately 64 input samples. If MUTE is applied to all channels for 1024 or more input samples the outputs will be connected directly to V_{MID} if IZD is set. When MUTE is de-asserted, the output will restart immediately from the current input sample.

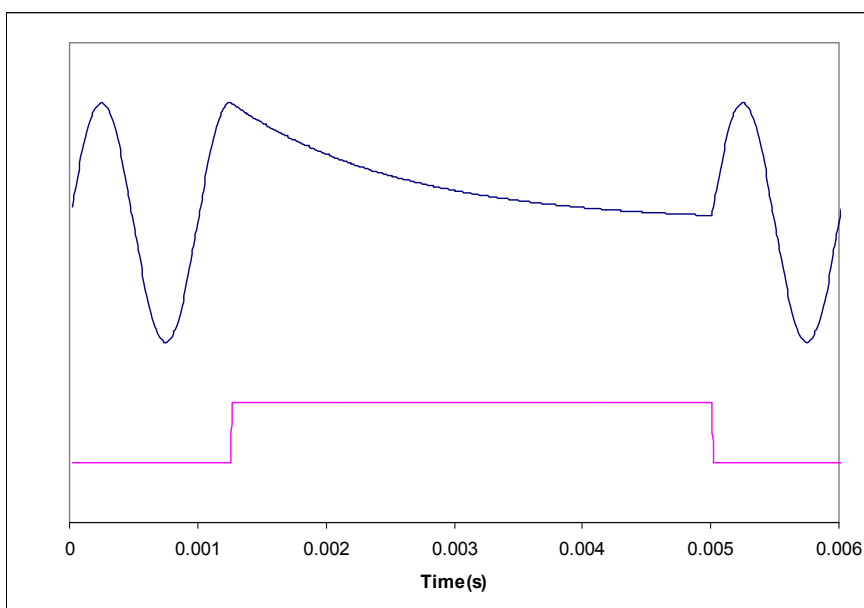

Figure 19 Application and Release of Soft Mute

The MUTE pin is an input to select mute or not mute. MUTE is active high; taking the pin high causes the filters to soft mute, ramping down the audio signal over a few milliseconds. Taking MUTE low again allows data into the filter.

The automute function detects a series of ZERO value audio samples of 1024 samples long being applied to both channels. After such an event, a latch is set whose output (AUTOMUTED) is wire OR'ed through a 10k Ω resistor to the MUTE pin. Thus if the MUTE pin is not being driven, the automute function will assert mute.

If MUTE is tied low, AUTOMUTED is overridden and will not mute unless the IZD register bit is set. If MUTE is driven from a bi-directional source, then both MUTE and automute functions are available. If MUTE is not driven, AUTOMUTED appears as a weak output (10k Ω source impedance) and can be used to drive external mute circuits. AUTOMUTED will be removed as soon as any channel receives a non-ZERO input.

A diagram showing how the various Mute modes interact is shown below Figure 20.

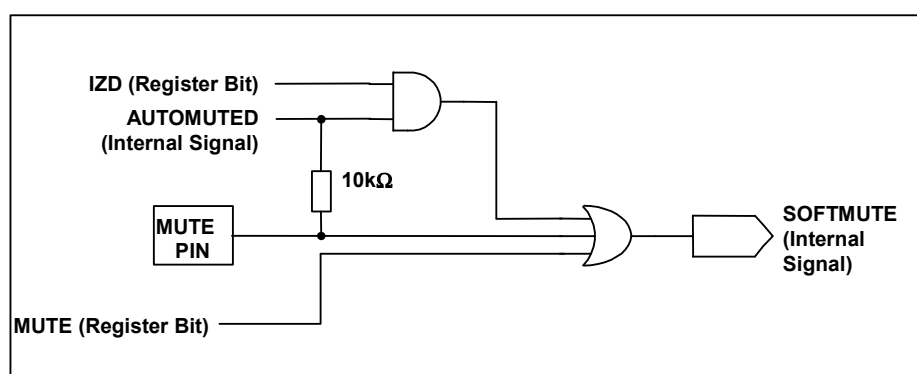

Figure 20 Selection Logic for MUTE Modes

INPUT FORMAT SELECTION

In hardware mode, ML/I2S and MC/IWL become input controls for selection of input data format type and input data word length for both the ADC and DAC.

ML/I2S	MC/IWL	INPUT DATA MODE
0	0	24-bit right justified
0	1	20-bit right justified
1	0	16-bit I ² S
1	1	24-bit I ² S

Table 8 Input Format Selection

Note:

In 24 bit I²S mode, any width of 24 bits or less is supported provided that the left/right clocks (LRC) are high for a minimum of 24 bit clocks (BCLK) and low for a minimum of 24 bit clocks.

DE-EMPHASIS CONTROL

In hardware mode, the MD/DM pin becomes an input control for selection of de-emphasis filtering to be applied.

MD/DM	DE-EMPHASIS
0	Off
1	On

Table 9 De-emphasis Control

DIGITAL AUDIO INTERFACE

MASTER AND SLAVE MODES

The audio interface operates in either Slave or Master mode, selectable using the MS control bit. In both Master and Slave modes DIN1/2/3 are always inputs to the WM8772 and DOUT is always an output. The default is Slave mode.

In Slave mode, LRC and BCLK are inputs to the WM8772 (Figure 21). DIN1/2/3 and LRC are sampled by the WM8772 on the rising edge of BCLK. ADC data is output on DOUT and changes on the falling edge of BCLK.

By setting the control bit BCP the polarity of BCLK may be reversed so that DIN1/2/3 and LRC are sampled on the falling edge of BCLK and DOUT changes on the rising edge of BCLK.

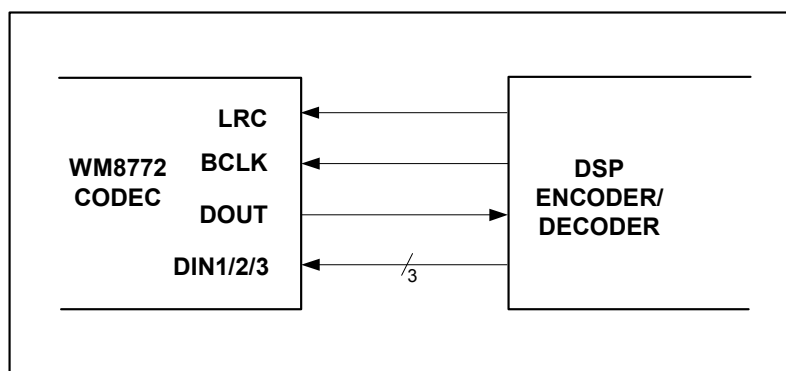

Figure 21 Slave Mode

In Master mode, LRC and BCLK are outputs from the WM8772 (Figure 22). LRC and BCLK are generated by the WM8772. DIN1/2/3 are sampled by the WM8772 on the rising edge of BCLK so the controller must output DAC data that changes on the falling edge of BCLK. ADC data is output on DOUT and changes on the falling edge of BCLK.

By setting control bit BCP the polarity of BCLK may be reversed so that DIN1/2/3 are sampled on the falling edge of BCLK, and DOUT changes on the rising edge of BCLK.

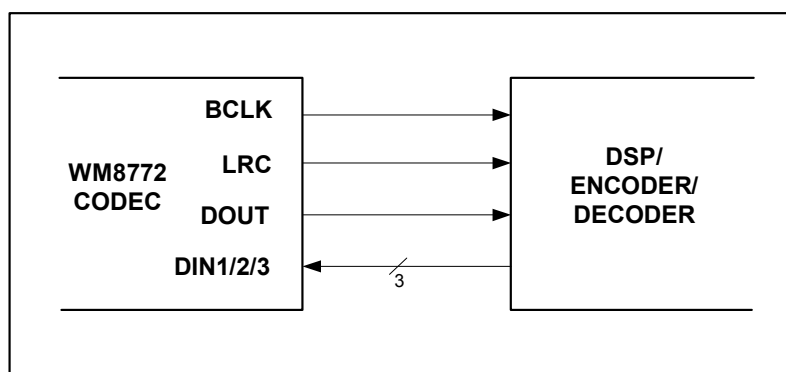

Figure 22 Master Mode

AUDIO INTERFACE FORMATS

Audio data is applied to the internal DAC filters, or output from the ADC filters, via the Digital Audio Interface. 5 popular interface formats are supported:

- Left Justified mode
- Right Justified mode
- I²S mode
- DSP mode A
- DSP mode B

All 5 formats send the MSB first and support word lengths of 16, 20, 24 and 32 bits, with the exception of 32 bit right justified mode, which is not supported.

In left justified, right justified and I²S modes, the digital audio interface receives DAC data on the DIN1/2/3 inputs and outputs ADC data on DOUT. Audio Data for each stereo channel is time multiplexed with LRC indicating whether the left or right channel is present. LRC is also used as a timing reference to indicate the beginning or end of the data words.

In left justified, right justified and I²S modes, the minimum number of BCLKs per LRC period is 2 times the selected word length. LRC must be high for a minimum of word length BCLKs and low for a minimum of word length BCLKs. Any mark to space ratio on LRC is acceptable provided the above requirements are met.

In DSP mode A or Mode B, all 6 DAC channels are time multiplexed onto DIN1. LRC is used as a frame sync signal to identify the MSB of the first word. The minimum number of BCLKs per LRC period is 6 times the selected word length. Any mark to space ratio is acceptable on LRC provided the rising edge is correctly positioned. The ADC data may also be output in DSP mode A or mode B, with LRC used as a frame sync to identify the MSB of the first word. The minimum number of BCLKs per LRC period is 2 times the selected word length if only the ADC is being operated.

LEFT JUSTIFIED MODE

In left justified mode, the MSB of DIN1/2/3 is sampled by the WM8772 on the first rising edge of BCLK following a LRC transition. The MSB of the ADC data is output on DOUT and changes on the same falling edge of BCLK as LRC and may be sampled on the rising edge of BCLK. LRC is high during the left samples and low during the right samples (Figure 23).

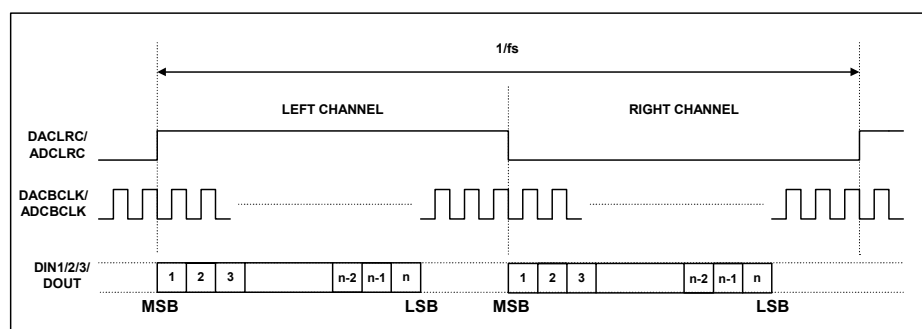

Figure 23 Left Justified Mode Timing Diagram

RIGHT JUSTIFIED MODE

In right justified mode, the LSB of DIN1/2/3 is sampled by the WM8772 on the rising edge of BCLK preceding a LRC transition. The LSB of the ADC data is output on DOUT and changes on the falling edge of BCLK preceding a LRC transition and may be sampled on the rising edge of BCLK. LRC are high during the left samples and low during the right samples (Figure 24).

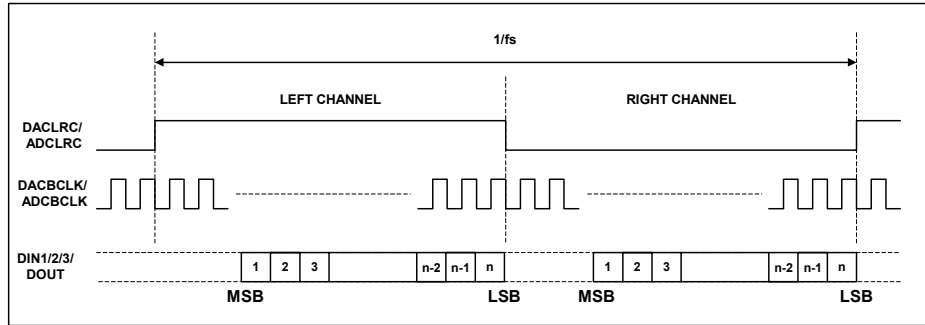

Figure 24 Right Justified Mode Timing Diagram

I²S MODE

In I²S mode, the MSB of DIN1/2/3 is sampled by the WM8772 on the second rising edge of BCLK following a LRC transition. The MSB of the ADC data is output on DOUT and changes on the first falling edge of BCLK following an LRC transition and may be sampled on the rising edge of BCLK. LRC are low during the left samples and high during the right samples.

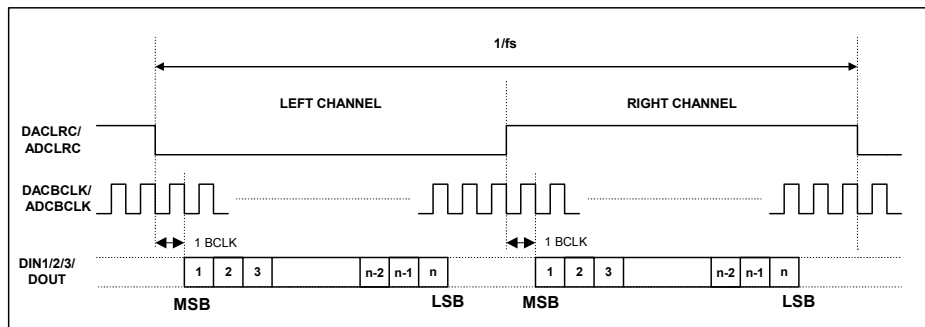

Figure 25 I²S Mode Timing Diagram

DSP MODE A

In DSP mode A, the MSB of DAC channel 1 left data is sampled by the WM8772 on the second rising edge on BCLK following a LRC rising edge. DAC channel 1 right and DAC channels 2 and 3 data follow DAC channel 1 left data (Figure 26).

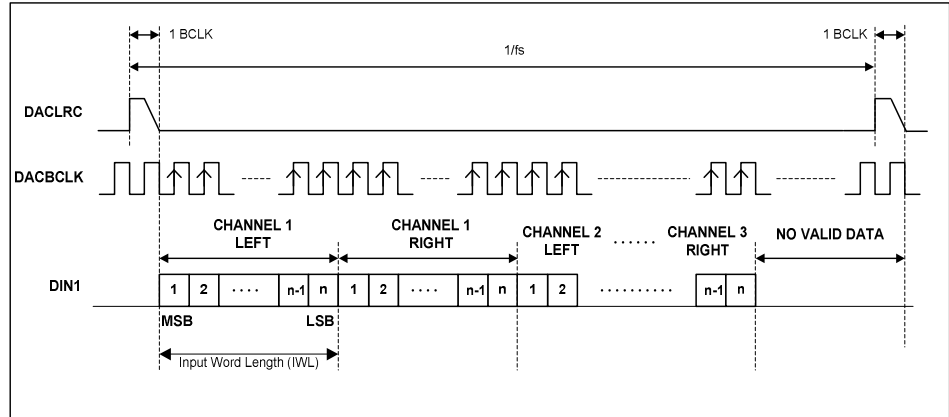

Figure 26 DSP Mode Audio Interface - Mode A Slave, DAC

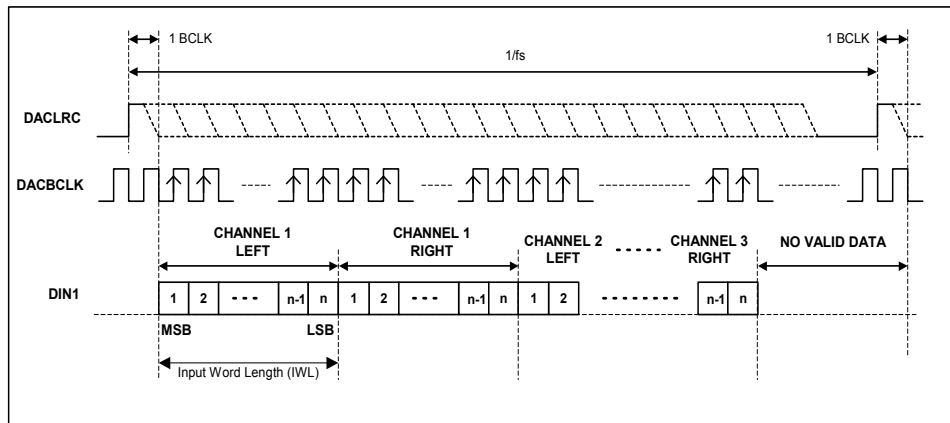

Figure 27 DSP Mode Audio Interface - Mode A Master, DAC

The MSB of the left channel ADC data is output on DOUT and changes on the first falling edge of BCLK following a low to high LRC transition and may be sampled on the rising edge of BCLK. The right channel ADC data is contiguous with the left channel data (Figure 26)

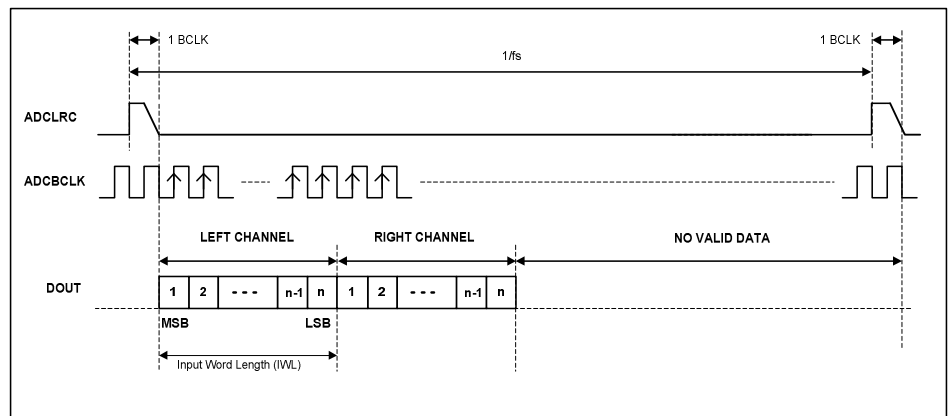

Figure 28 DSP Mode Audio Interface - Mode A Slave, ADC

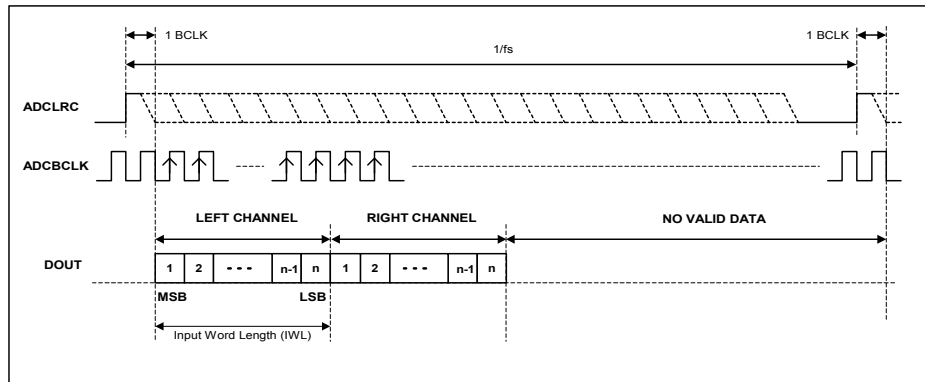

Figure 29 DSP Mode Audio Interface - Mode A Master, ADC

DSP MODE B

In DSP mode B, the MSB of DAC channel 1 left data is sampled by the WM8772 on the first BCLK rising edge following a LRC rising edge. DAC channel 1 right and DAC channels 2 and 3 data follow DAC channel 1 left data (Figure 30).

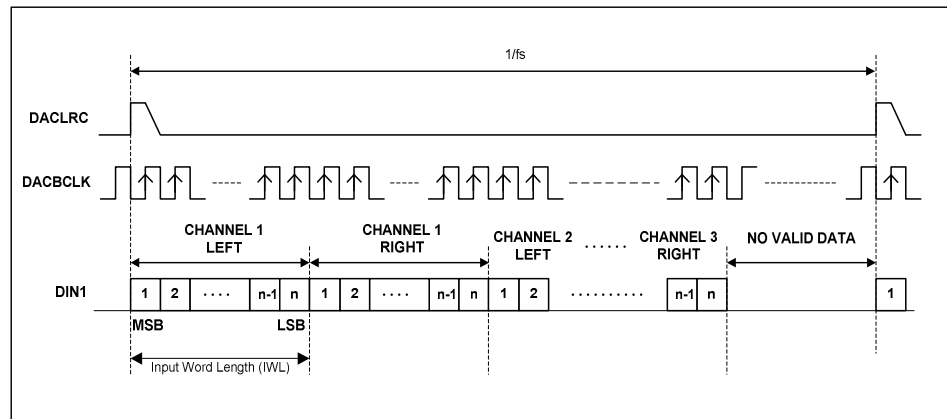

Figure 30 DSP Mode Audio Interface - Mode B Slave, DAC

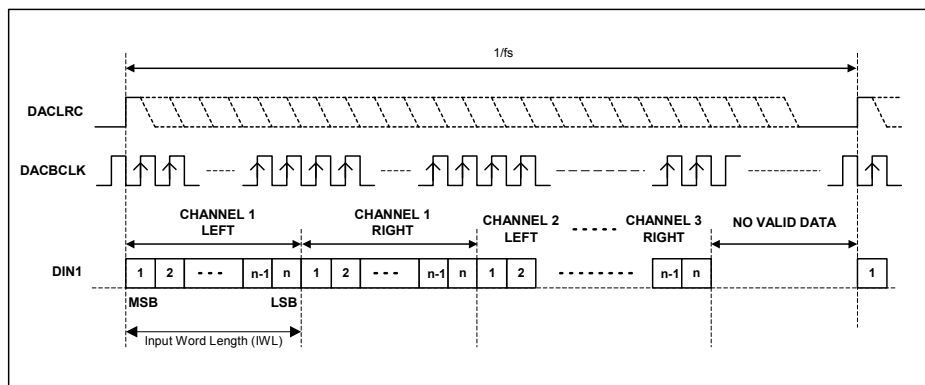

Figure 31 DSP Mode Audio Interface - Mode B Master, DAC

The MSB of the left channel ADC data is output on DOUT and changes on the same falling edge of BCLK as the low to high LRC transition and may be sampled on the rising edge of BCLK. The right channel ADC data is contiguous with the left channel data (Figure 32).

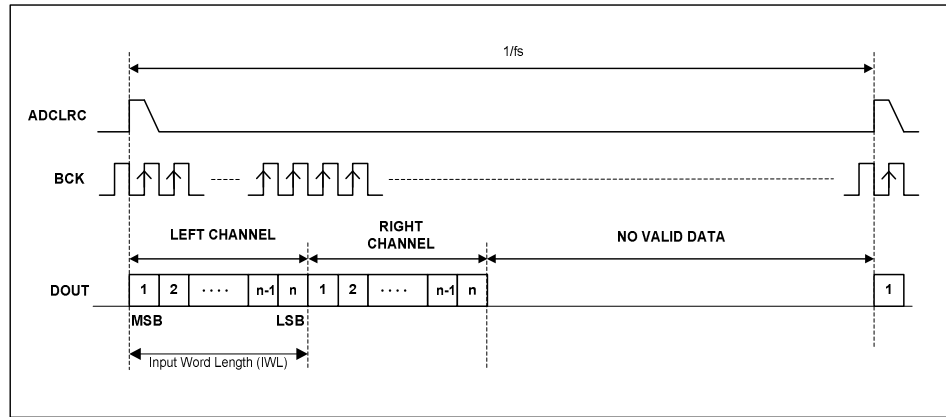

Figure 32 DSP Mode Audio Interface - Mode B Slave, ADC

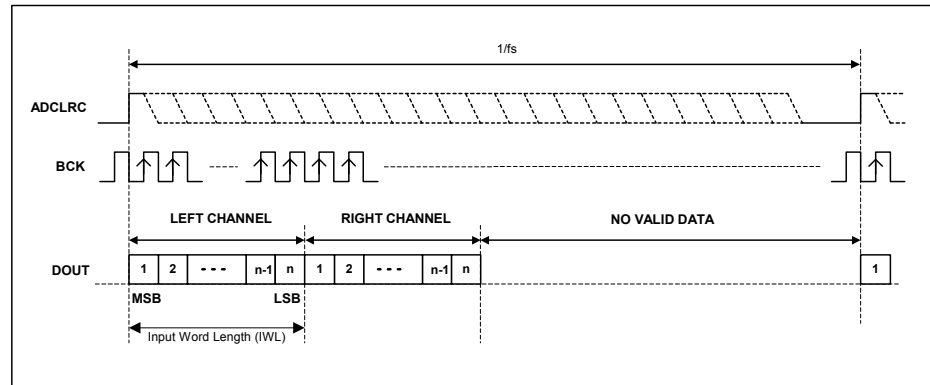

Figure 33 DSP Mode Audio Interface - Mode B Master, ADC

In both DSP mode A and mode B, DACL1 is always sent first, followed immediately by DACR1 and the data words for the other 6 channels. No BCLK edges are allowed between the data words. The word order is DAC1 left, DAC1 right, DAC2 left, DAC2 right, DAC3 left, DAC3 right.

POWERDOWN MODES

The WM8772 has powerdown control bits allowing specific parts of the WM8772 to be powered off when not being used. Control bit ADCPD powers off the ADC. The three stereo DACs each have a separate powerdown control bit, DACPD[2:0] allowing individual stereo DACs to be powered off when not in use. Setting ADCPD and DACPD[2:0] will powerdown everything except the references VMID and REFADC. These may be powered down by setting PDWN. Setting PDWN will override all other powerdown control bits. It is recommended that the ADC and DACs are powered down before setting PDWN.

ZERO DETECT

The WM8772 has a zero detect circuit for each DAC channel that detects when 1024 consecutive zero samples have been input. The MUTE pin output may be programmed to output the zero detect signal (see Table 10) which may then be used to control external muting circuits. A '1' on MUTE indicates a zero detect. The zero detect may also be used to automatically enable DAC mute by setting IZD.

DZFM[1:0]	MUTE
00	All channels zero
01	Channel 1 zero
10	Channel 2 zero
11	Channel 3 zero

Table 10 Zero Flag Output Select

SOFTWARE CONTROL INTERFACE OPERATION

The WM8772 is controlled using a 3-wire serial interface in software mode or pin programmable in hardware mode.

The control mode is selected by the state of the MODE pin.

3-WIRE (SPI COMPATIBLE) SERIAL CONTROL MODE

MD/DM is used for the program data, MC/IWL is used to clock in the program data and ML/I2S is used to latch the program data. MD/DM is sampled on the rising edge of MC/IWL. The 3-wire interface protocol is shown in Figure 34.

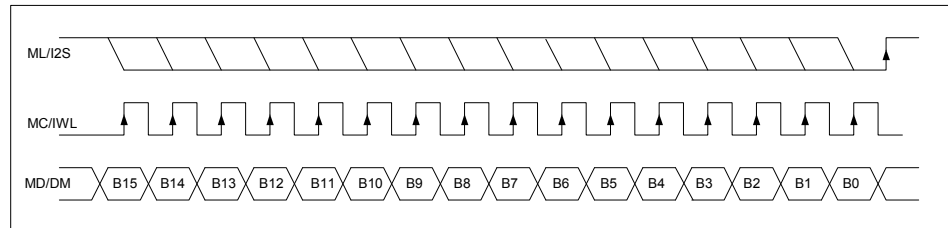

Figure 34 3-Wire SPI Compatible Interface

1. B[15:9] are Control Address Bits
2. B[8:0] are Control Data Bits
3. ML/I2S is edge sensitive – the data is latched on the rising edge of ML/I2S.

REGISTER MAP

The complete register map is shown below. The detailed description can be found in the relevant text of the device description. The WM8772 can be configured using the Control Interface. All unused bits should be set to '0'.

REGISTER	B15	B14	B13	B12	B11	B10	B9	B8	B7	B6	B5	B4	B3	B2	B1	B0	DEFAULT
R0(00h)	0	0	0	0	0	0	0	UPDATE	LDA1[7:0]								01111111
R1(01h)	0	0	0	0	0	0	1	UPDATE	RDA1[7:0]								01111111
R2(02h)	0	0	0	0	0	1	0	PL[8:5]			IZD	ATC	PDWN All DAC	DEEMP	MUTE All DAC	10010000	
R3(03h)	0	0	0	0	0	1	1	PHASE[8:6]			IWL[5:4]		BCP	LRP	FMT[1:0]		00000000
R4(04h)	0	0	0	0	1	0	0	UPDATE	LDA2[7:0]								01111111
R5(05h)	0	0	0	0	1	0	1	UPDATE	RDA2[7:0]								01111111
R6(06h)	0	0	0	0	1	1	0	UPDATE	LDA3[7:0]								01111111
R7(07h)	0	0	0	0	1	1	1	UPDATE	RDA3[7:0]								01111111
R8(08h)	0	0	0	1	0	0	0	UPDATE	MASTDA[7:0]								01111111
R9(09h)	0	0	0	1	0	0	1	DEEMP[8:6]			DMUTE[5:3]			DZFM[2:1]		ZCD	00000000
R10(0Ah)	0	0	0	1	0	1	0	RATE[8:6]			MS	PDWN All	DACPD[3:1]		ADCPD	01000000	
R11(0Bh)	0	0	0	1	0	1	1	ADC OSR	010			0	00		00		00100000
R12(0Ch)	0	0	0	1	1	0	0	0	0	MPD	0	0	ADCHP	AMUTE ALL	AMUTEL	AMUTER	00000000
R31(1Fh)	0	0	1	1	1	1	1	RESET								00000000	

CONTROL INTERFACE REGISTERS

ATTENUATOR CONTROL MODE

Setting the ATC register bit causes the left channel attenuation settings to be applied to both left and right channel DACs from the next audio input sample. No update to the attenuation registers is required for ATC to take effect.

REGISTER ADDRESS	BIT	LABEL	DEFAULT	DESCRIPTION
0000010 DAC Channel Control	3	ATC	0	Attenuator Control Mode: 0: Right channels use right attenuations 1: Right channels use left attenuations

INFINITE ZERO DETECT ENABLE

Setting the IZD register bit will enable the internal infinite zero detect function:

REGISTER ADDRESS	BIT	LABEL	DEFAULT	DESCRIPTION
0000010 DAC Channel Control	4	IZD	0	Infinite Zero Mute Enable 0 : Disable infinite zero mute 1: Enable infinite zero mute

With IZD enabled, applying 1024 consecutive zero input samples each stereo channel will cause that stereo channel outputs to be muted to V_{MID} . Mute will be removed as soon as that stereo channel receives a non-zero input.

DAC OUTPUT CONTROL

The DAC output control word determines how the left and right inputs to the audio Interface are applied to the left and right DACs:

REGISTER ADDRESS	BIT	LABEL	DEFAULT	DESCRIPTION		
0000010 DAC Control	8:5	PL[3:0]	1001	PL[3:0]	Left Output	Right Output
				0000	Mute	Mute
				0001	Left	Mute
				0010	Right	Mute
				0011	(L+R)/2	Mute
				0100	Mute	Left
				0101	Left	Left
				0110	Right	Left
				0111	(L+R)/2	Left
				1000	Mute	Right
				1001	Left	Right
				1010	Right	Right
				1011	(L+R)/2	Right
				1100	Mute	(L+R)/2
				1101	Left	(L+R)/2
				1110	Right	(L+R)/2
1111	(L+R)/2	(L+R)/2				

ADC AND DAC DIGITAL AUDIO INTERFACE CONTROL REGISTER

Interface format is selected via the FMT[1:0] register bits:

REGISTER ADDRESS	BIT	LABEL	DEFAULT	DESCRIPTION
0000011 Interface Control	1:0	FMT [1:0]	00	Interface Format Select: 00 : Right justified mode 01: Left justified mode 10: I ² S mode 11: DSP mode A or B

In left justified, right justified or I²S modes, the LRP register bit controls the polarity of LRC. If this bit is set high, the expected polarity of LRC will be the opposite of that shown Figure 23, Figure 24 and Figure 25. Note that if this feature is used as a means of swapping the left and right channels, a 1 sample phase difference will be introduced. In DSP modes, the LRP register bit is used to select between mode A and mode B.

REGISTER ADDRESS	BIT	LABEL	DEFAULT	DESCRIPTION
0000011 Interface Control	2	LRP	0	In left/right/I ² S Modes: LRC Polarity (normal) 0 : Normal LRC polarity 1: Inverted LRC polarity
				In DSP Mode: 0 : DSP mode A 1: DSP mode B

By default, LRC and DIN1/2/3 are sampled on the rising edge of BCLK and should ideally change on the falling edge. By default, LRC and DOUT are sampled on the rising edge of BCLK and should ideally change on the falling edge. Data sources that change LRC and DOUT on the rising edge of BCLK can be supported by setting the BCP register bit. Data sources that change LRC and DIN1/2/3 on the rising edge of BCLK can be supported by setting the BCP register bit. Setting BCP to 1 inverts the polarity of BCLK to the inverse of that shown in Figure 23 to Figure 33.

REGISTER ADDRESS	BIT	LABEL	DEFAULT	DESCRIPTION
0000011 Interface Control	3	BCP	0	BCLK Polarity (DSP Modes): 0: Normal BCLK polarity 1: Inverted BCLK polarity

The IWL[1:0] bits are used to control the input word length.

REGISTER ADDRESS	BIT	LABEL	DEFAULT	DESCRIPTION
0000011 Interface Control	5:4	IWL [1:0]	00	Input Word Length: 00 : 16 bit data 01: 20 bit data 10: 24 bit data 11: 32 bit data

Note: 32-bit right justified mode is not supported.

In all modes, the data is signed 2's complement. The digital filters always input 24-bit data. If the DAC is programmed to receive 16 or 20 bit data, the WM8772 pads the unused LSBs with zeros. If the DAC is programmed into 32 bit mode, the 8 LSBs are ignored.

Note: In 24 bit I²S mode, any width of 24 bits or less is supported provided that LRC is high for a minimum of 24 BCLKs and low for a minimum of 24 BCLKs.

A number of options are available to control how data from the Digital Audio Interface is applied to the DAC channels.

DAC OUTPUT PHASE

The DAC Phase control word determines whether the output of each DAC is non-inverted or inverted

REGISTER ADDRESS	BIT	LABEL	DEFAULT	DESCRIPTION		
0000011 DAC Phase	8:6	PHASE [2:0]	000	Bit	DAC	Phase
				0	DAC1L/R	1 = invert
				1	DAC2L/R	1 = invert
				2	DAC3L/R	1 = invert

DIGITAL ZERO CROSS-DETECT

The Digital volume control also incorporates a zero cross detect circuit which detects a transition through the zero point before updating the digital volume control with the new volume. This is enabled by control bit DZCEN.

REGISTER ADDRESS	BIT	LABEL	DEFAULT	DESCRIPTION
0001001 DAC Control	0	ZCD	0	DAC Digital Volume Zero Cross Disable: 0: Zero cross detect enabled 1: Zero cross detect disabled

MUTE FLAG OUTPUT

The DZFM control bits allow the selection of the six DAC channel zero flag bits for output on the MUTE pin. A '1' on MUTE indicates 1024 consecutive zero input samples to the DAC channels selected.

REGISTER ADDRESS	BIT	LABEL	DEFAULT	DESCRIPTION
0001001 Zero Flag	2:1	DZFM[1:0]	00	Selects the output MUTE pin (A '1' indicates 1024 consecutive zero input samples on the DAC channels selected. 00: All channels zero 01: Channel 1 zero 10: Channel 2 zero 11: Channel 3 zero

DAC MUTE MODES

The WM8772 has individual mutes for each of the three DAC channels. Setting MUTE for a channel will apply a 'soft' mute to the input of the digital filters of the channel muted.

REGISTER ADDRESS	BIT	LABEL	DEFAULT	DESCRIPTION
0001001 DAC Mute	5:3	DMUTE [2:0]	000	DAC Soft Mute Select

DMUTE [2:0]	DAC CHANNEL 1	DAC CHANNEL 2	DAC CHANNEL 3
000	Not MUTE	Not MUTE	Not MUTE
001	MUTE	Not MUTE	Not MUTE
010	Not MUTE	MUTE	Not MUTE
011	MUTE	MUTE	Not MUTE
100	Not MUTE	Not MUTE	MUTE
101	MUTE	Not MUTE	MUTE
110	Not MUTE	MUTE	MUTE

Setting the MUTEALL register bit will apply a 'soft' mute to the input of all the DAC digital filters:

REGISTER ADDRESS	BIT	LABEL	DEFAULT	DESCRIPTION
0000010 DAC Mute	0	MUTEALL	0	Soft Mute Select: 0 : Normal operation 1: Soft mute all channels

Refer to Figure 19 for the plot of application and release of soft mute.

Note that all other means of muting the DAC channels: setting the PL[3:0] bits to 0, setting the PDWN bit or setting attenuation to 0 will cause much more abrupt muting of the output.

ADC MUTE MODES

Each ADC channel also has a mute control bit, which mutes the inputs to the ADC.

REGISTER ADDRESS	BIT	LABEL	DEFAULT	DESCRIPTION
0001100 ADC Mute	0	AMUTER	0	ADC Mute Select: 0 : Normal operation 1: mute ADC right
	1	AMUTEL	0	ADC Mute Select: 0 : Normal operation 1: mute ADC left
	2	AMUTEALL	0	ADC Mute Select: 0 : Normal operation 1: mute both ADC channels

DE-EMPHASIS MODE

Each stereo DAC channel has an individual de-emphasis control bit:

REGISTER ADDRESS	BIT	LABEL	DEFAULT	DESCRIPTION
0001001 DAC De-Emphasis Control	[8:6]	DEEMPH [1:0]	000	De-emphasis Channel Selection Select:

DEEMPH [1:0]	DAC CHANNEL 1	DAC CHANNEL 2	DAC CHANNEL 3
000	Not DE-EMPHASIS	Not DE-EMPHASIS	Not DE-EMPHASIS
001	DE-EMPHASIS	Not DE-EMPHASIS	Not DE-EMPHASIS
010	Not DE-EMPHASIS	DE-EMPHASIS	Not DE-EMPHASIS
011	DE-EMPHASIS	DE-EMPHASIS	Not DE-EMPHASIS
100	Not DE-EMPHASIS	Not DE-EMPHASIS	DE-EMPHASIS
101	DE-EMPHASIS	Not DE-EMPHASIS	DE-EMPHASIS
110	Not DE-EMPHASIS	DE-EMPHASIS	DE-EMPHASIS

Refer to Figure 7, Figure 8, Figure 9, Figure 10, Figure 11 and Figure 12 for details of the De-Emphasis performance at different sample rates.

REGISTER ADDRESS	BIT	LABEL	DEFAULT	DESCRIPTION
0000010 DAC DEMP	1	DEEMP ALL	0	DEMMP Select: 0 : Normal operation 1: De-emphasis all channels

POWERDOWN MODE AND ADC/DAC DISABLE

Setting the PDWN register bit immediately powers down the DAC's on the WM8772, overriding the DACD powerdown bits control bits. All trace of the previous input samples are removed, but all control register settings are preserved. When PDWN is cleared the digital filters will be reinitialised

REGISTER ADDRESS	BIT	LABEL	DEFAULT	DESCRIPTION
0000010 Powerdown Control	2	PDWN	0	Power Down all DAC's Select: 0: All DAC's enabled 1: All DAC's disabled

The ADC and DACs may also be powered down individually by setting the ADCPD and DACPD disable bits. Setting ADCD will disable the ADC and select a low power mode. The ADC digital filters will be reset and will reinitialise when ADCPD is unset. Each Stereo DAC channel has a separate disable DACPD[2:0]. Setting DACPD for a channel will disable the DACs and select a low power mode.

REGISTER ADDRESS	BIT	LABEL	DEFAULT	DESCRIPTION
0001010 Powerdown Control	0	ADCPD	0	ADC Disable: 0: Active 1: Disable
	3:1	DACPD[2:0]	000	DAC Disable

DACPD [2:0]	DAC CHANNEL 1	DAC CHANNEL 2	DAC CHANNEL 3
000	Active	Active	Active
001	DISABLE	Active	Active
010	Active	DISABLE	Active
011	DISABLE	DISABLE	Active
100	Active	Active	DISABLE
101	DISABLE	Active	DISABLE
110	Active	DISABLE	DISABLE
111	DISABLE	DISABLE	DISABLE

MASTER POWERDOWN

This control bit powers down the references for the whole chop. Therefore for complete powerdown, both the ADC and DACs should be powered down first before setting this bit.

REGISTER ADDRESS	BIT	LABEL	DEFAULT	DESCRIPTION
0001010 Interface Control	4	PWRDNALL	0	Master Power Down Bit: 0: Not powered down 1: Powered down

MASTER MODE SELECT

Control bit MS selects between audio interface Master and Slave Modes. In Master mode LRC and BCLK are outputs and are generated by the WM8772. In Slave mode LRC and BCLK are inputs to WM8772.

REGISTER ADDRESS	BIT	LABEL	DEFAULT	DESCRIPTION
0001010 Interface Control	5	MS	0	DAC Audio Interface Master/Slave Mode Select: 0: Slave mode 1: Master mode

MASTER MODE LRC FREQUENCY SELECT

In Master mode the WM8772 generates LRC and BCLK. These clocks are derived from the master clock and the ratio of MCLK to LRC is set by RATE.

REGISTER ADDRESS	BIT	LABEL	DEFAULT	DESCRIPTION
0001010 Interface Control	8:6	RATE [2:0]	010	Master Mode MCLK:LRC Ratio Select: 000: 128fs (DAC only) 001: 192fs (DAC only) 010: 256fs 011: 384fs 100: 512fs 101: 768fs

ADC OVERSAMPLING RATE SELECT

For ADC operation at 96kHz it is recommended that the user set the ADCOSR bit. This changes the ADC signal processing oversample rate to 64fs. The 64fs oversampling rate is only available in modes where a 96kHz rate is supported, i.e. 256fs or 384fs. In all other modes the ADC will stay in a 128fs oversampling rate irrespective of what this bit is set to.

REGISTER ADDRESS	BIT	LABEL	DEFAULT	DESCRIPTION
0001011 ADC Oversampling Rate	8	ADCOSR	0	ADC Oversampling Rate Select: 0: 128x oversampling 1: 64x oversampling

ADC HIGHPASS FILTER DISABLE

The ADC digital filters contain a digital highpass filter. This defaults to enabled and can be disabled using software control bit ADCHPD.

REGISTER ADDRESS	BIT	LABEL	DEFAULT	DESCRIPTION
0001100 ADC Control	3	ADCHPD	0	ADC Highpass Filter Disable: 0: Highpass filter enabled 1: Highpass filter disabled

MUTE PIN DECODE

The MUTE pin can either be used as an output or an input. When used as an input the MUTE pins action can be controlled by setting the DZFM bit to select the corresponding DAC for applying the MUTE to. As an output its meaning is selected by the DZFM control bits. By default selecting the MUTE to represent if DAC1 has received more than 1024 midrail samples will cause the MUTE to be asserted a softmute on DAC1. Disabling the decode block will cause any logical high on the MUTE pin to apply a softmute to all DAC's.

REGISTER ADDRESS	BIT	LABEL	DEFAULT	DESCRIPTION
0001100 ADC Control	6	MPD	0	MUTE Pin Decode Disable: 0: MUTE pin decode enable 1: MUTE pin decode disable

DAC DIGITAL VOLUME CONTROL

The DAC volume may also be adjusted in the digital domain using independent digital attenuation control registers

REGISTER ADDRESS	BIT	LABEL	DEFAULT	DESCRIPTION
0000000 Digital Attenuation DACL1	7:0	LDA1[7:0]	11111111 (0dB)	Digital Attenuation data for Left channel DACL1 in 0.5dB steps. See Table 11
	8	UPDATE	Not latched	Controls simultaneous update of all Attenuation Latches 0: Store LDA1 in intermediate latch (no change to output) 1: Store LDA1 and update attenuation on all channels
0000001 Digital Attenuation DACR1	7:0	RDA1[6:0]	11111111 (0dB)	Digital Attenuation data for Right channel DACR1 in 0.5dB steps. See Table 11
	8	UPDATE	Not latched	Controls simultaneous update of all Attenuation Latches 0: Store RDA1 in intermediate latch (no change to output) 1: Store RDA1 and update attenuation on all channels.
0000100 Digital Attenuation DACL2	7:0	LDA2[7:0]	11111111 (0dB)	Digital Attenuation data for Left channel DACL2 in 0.5dB steps. See Table 11
	8	UPDATE	Not latched	Controls simultaneous update of all Attenuation Latches 0: Store LDA2 in intermediate latch (no change to output) 1: Store LDA2 and update attenuation on all channels.
0000101 Digital Attenuation DACR2	7:0	RDA2[7:0]	11111111 (0dB)	Digital Attenuation data for Right channel DACR2 in 0.5dB steps. See Table 11
	8	UPDATE	Not latched	Controls simultaneous update of all Attenuation Latches 0: Store RDA2 in intermediate latch (no change to output) 1: Store RDA2 and update attenuation on all channels.
0000110 Digital Attenuation DACL3	7:0	LDA3[7:0]	11111111 (0dB)	Digital Attenuation data for Left channel DACL3 in 0.5dB steps. See Table 11
	8	UPDATE	Not latched	Controls simultaneous update of all Attenuation Latches 0: Store LDA3 in intermediate latch (no change to output) 1: Store LDA3 and update attenuation on all channels.
0000111 Digital Attenuation DACR3	7:0	RDA3[7:0]	11111111 (0dB)	Digital Attenuation data for Right channel DACR3 in 0.5dB steps. See Table 11
	8	UPDATE	Not latched	Controls simultaneous update of all Attenuation Latches 0: Store RDA3 in intermediate latch (no change to output) 1: Store RDA3 and update attenuation on all channels.
0001000 Master Digital Attenuation (all channels)	7:0	MASTDA [7:0]	11111111 (0dB)	Digital Attenuation data for all DAC channels in 0.5dB steps. See Table 11
	8	UPDATE	Not latched	Controls simultaneous update of all Attenuation Latches 0: Store gain in intermediate latch (no change to output) 1: Store gain and update attenuation on all channels.

L/RDAX[7:0]	ATTENUATION LEVEL
00(hex)	-∞ dB (mute)
01(hex)	-127dB
:	:
:	:
:	:
FE(hex)	-0.5dB
FF(hex)	0dB

Table 11 Digital Volume Control Attenuation Levels

SOFTWARE REGISTER RESET

Writing to register 11111 will cause a register reset, resetting all register bits to their default values. The device will be held in this reset state until a subsequent register write to any address is completed.

APPLICATIONS INFORMATION

RECOMMENDED EXTERNAL COMPONENTS

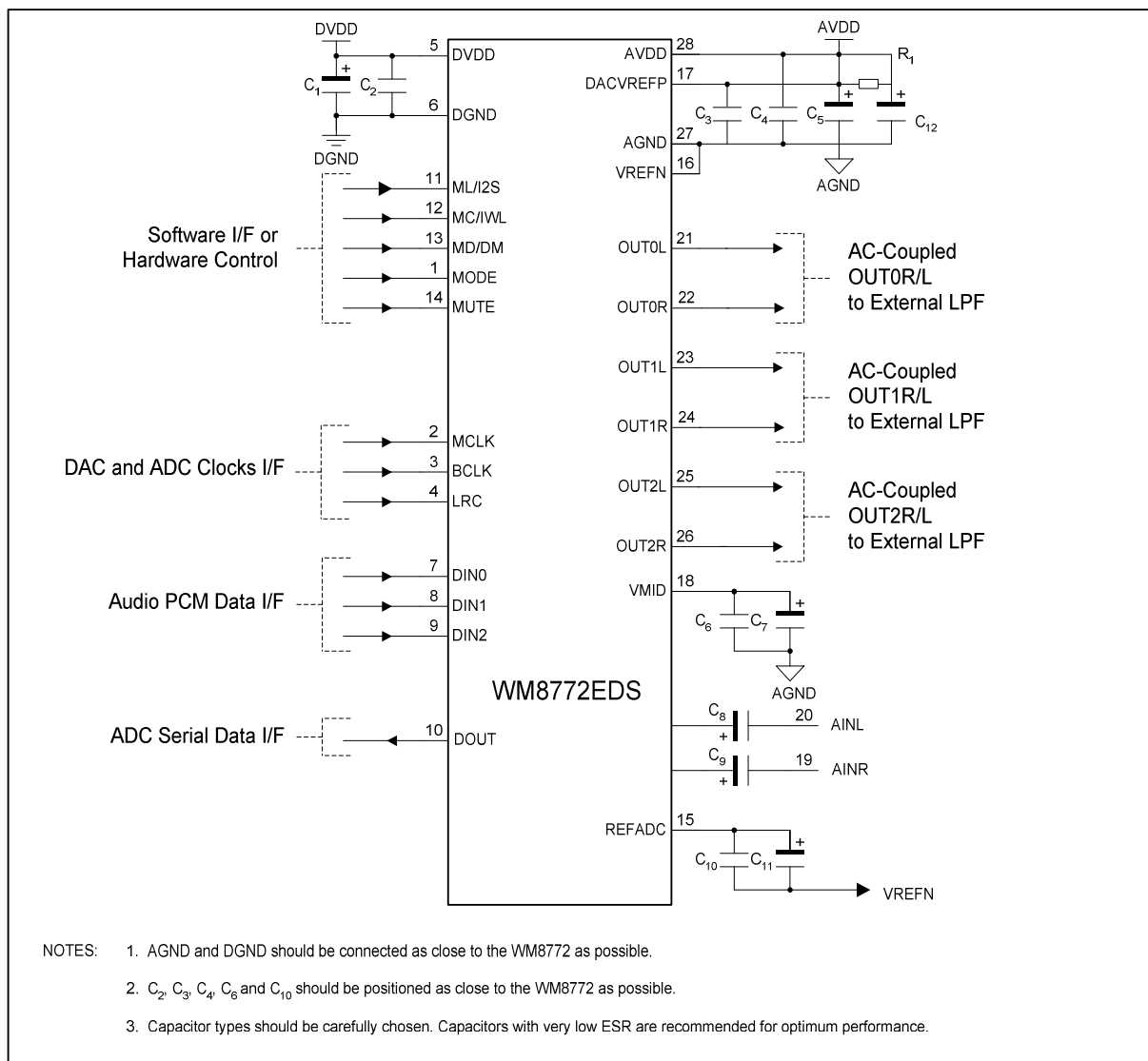

RECOMMENDED EXTERNAL COMPONENTS VALUES

COMPONENT REFERENCE	SUGGESTED VALUE	DESCRIPTION
C1 and C5	10µF	De-coupling for DVDD and AVDD.
C2 to C4	0.1µF	De-coupling for DVDD and AVDD.
C8 and C9	1µF	Analogue input high pass filter capacitors
C6 and C10	0.1µF	Reference de-coupling capacitors for VMID and ADCREF pin.
C7 and C11	10µF	
C12	10µF	Filtering for VREFP. Omit if AVDD low noise.
R1	33Ω	Filtering for VREFP. Use 0Ω if AVDD low noise.

Table 12 External Components Description

SUGGESTED ANALOGUE LOW PASS POST DAC FILTERS

It is recommended that a lowpass filter be applied to the output from each DAC channel for Hi Fi applications. Typically a second order filter is suitable and provides sufficient attenuation of high frequency components (the unique low order, high bit count multi-bit sigma delta DAC structure used in WM8772 produces much less high frequency output noise than normal sigma delta DACs. This filter is typically also used to provide the 2x gain needed to provide the standard 2Vrms output level from most consumer equipment.

Figure 35 shows a suitable post DAC filter circuit, with 2x gain. Alternative inverting filter architectures might also be used with as good results.

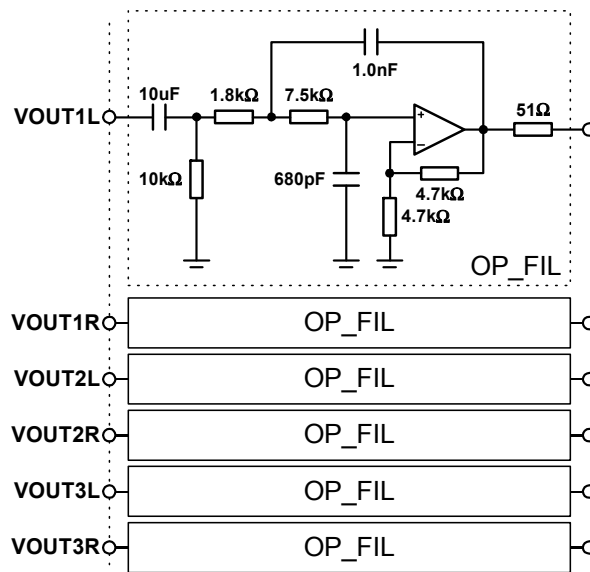

Figure 35 Recommended Post DAC Filter Circuit

To ensure that system 'pop' noise is kept to a minimum when power is applied or removed, a transistor clamp circuit arrangement may be added to the output connectors of the system. A recommended clamp circuit configuration is shown below.

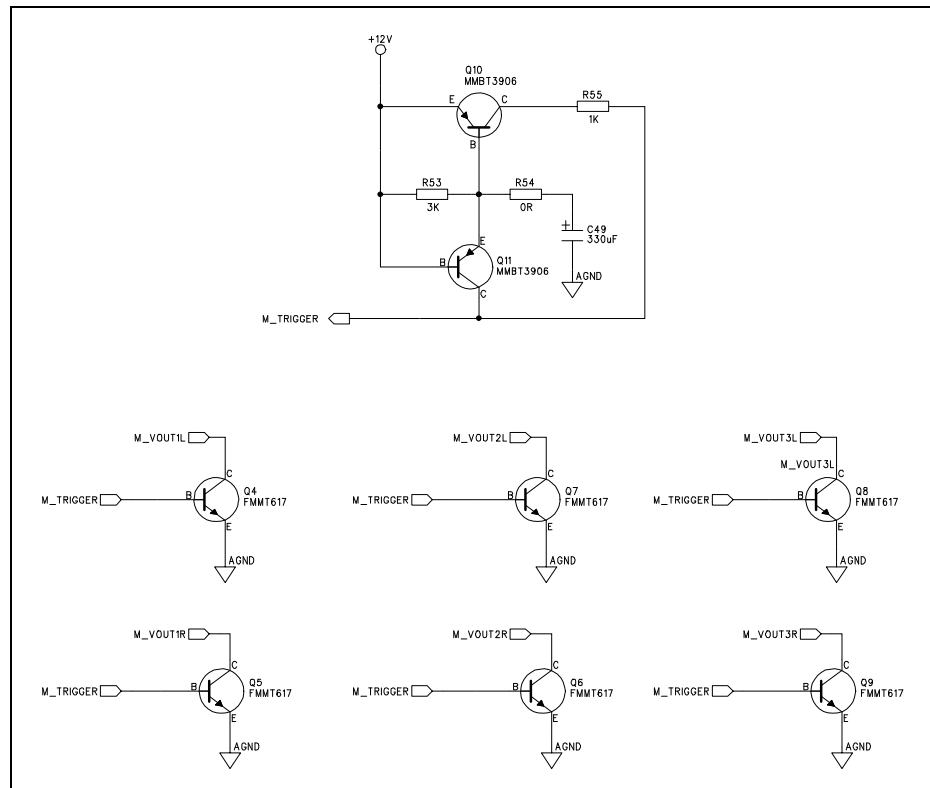

Figure 36 Output Clamp Circuit

When the +VS power supply is applied, PNP transistor Q10 of the trigger circuit is held on until capacitor C49 is fully charged. With transistor Q10 held 'on', NPN transistors Q4 to Q9 of the clamp circuits are also switched on holding the system outputs near to GND. When capacitor C49 is fully charged transistors Q10 and Q4 to Q9 are switched off setting the outputs active.

When the +VS power supply is removed, PNP transistor Q11 of the trigger circuit is switched on. In turn, transistors Q4 to Q9 of the clamp circuits are switched on holding the outputs of the evaluation board near to GND until the rest of the circuitry on the board has settled.

Note: It is recommended that low $V_{ce_{sat}}$ switching transistors should be used in this circuit to ensure that the clamp is applied before the rest of the circuitry has time to power down.

Important: If a trigger circuit such as the one shown is to be used, it is important that the +VS supply drops quicker than any other supply to ensure that the outputs are clamped during the period when 'pop' noise may occur.

PACKAGE DIMENSIONS

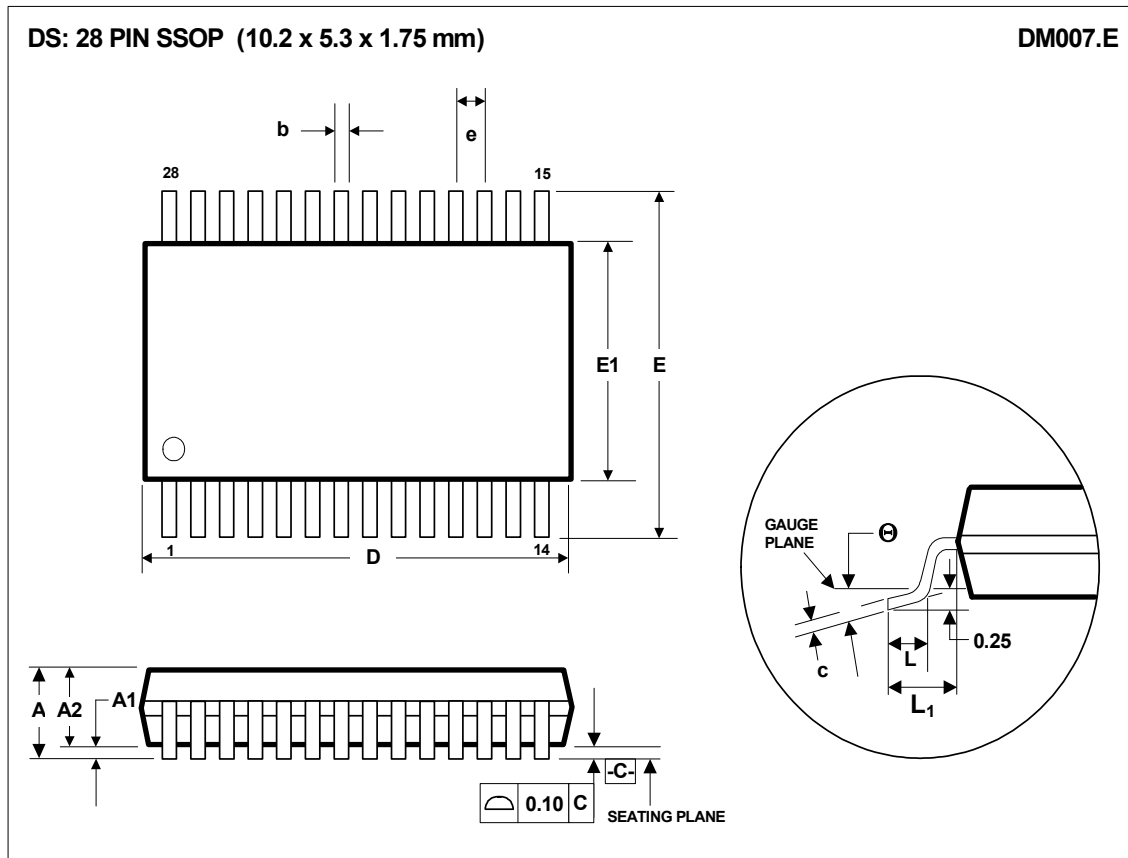

Symbols	Dimensions (mm)		
	MIN	NOM	MAX
A	----	----	2.0
A₁	0.05	----	0.25
A₂	1.65	1.75	1.85
b	0.22	0.30	0.38
c	0.09	----	0.25
D	9.90	10.20	10.50
e	0.65 BSC		
E	7.40	7.80	8.20
E₁	5.00	5.30	5.60
L	0.55	0.75	0.95
L₁	1.25 REF		
θ	0°	4°	8°
REF:	JEDEC.95, MO-150		

- NOTES:
- A. ALL LINEAR DIMENSIONS ARE IN MILLIMETERS.
 - B. THIS DRAWING IS SUBJECT TO CHANGE WITHOUT NOTICE.
 - C. BODY DIMENSIONS DO NOT INCLUDE MOLD FLASH OR PROTRUSION, NOT TO EXCEED 0.20MM.
 - D. MEETS JEDEC.95 MO-150, VARIATION = AH. REFER TO THIS SPECIFICATION FOR FURTHER DETAILS.

IMPORTANT NOTICE

Wolfson Microelectronics plc ("Wolfson") products and services are sold subject to Wolfson's terms and conditions of sale, delivery and payment supplied at the time of order acknowledgement.

Wolfson warrants performance of its products to the specifications in effect at the date of shipment. Wolfson reserves the right to make changes to its products and specifications or to discontinue any product or service without notice. Customers should therefore obtain the latest version of relevant information from Wolfson to verify that the information is current.

Testing and other quality control techniques are utilised to the extent Wolfson deems necessary to support its warranty. Specific testing of all parameters of each device is not necessarily performed unless required by law or regulation.

In order to minimise risks associated with customer applications, the customer must use adequate design and operating safeguards to minimise inherent or procedural hazards. Wolfson is not liable for applications assistance or customer product design. The customer is solely responsible for its selection and use of Wolfson products. Wolfson is not liable for such selection or use nor for use of any circuitry other than circuitry entirely embodied in a Wolfson product.

Wolfson's products are not intended for use in life support systems, appliances, nuclear systems or systems where malfunction can reasonably be expected to result in personal injury, death or severe property or environmental damage. Any use of products by the customer for such purposes is at the customer's own risk.

Wolfson does not grant any licence (express or implied) under any patent right, copyright, mask work right or other intellectual property right of Wolfson covering or relating to any combination, machine, or process in which its products or services might be or are used. Any provision or publication of any third party's products or services does not constitute Wolfson's approval, licence, warranty or endorsement thereof. Any third party trade marks contained in this document belong to the respective third party owner.

Reproduction of information from Wolfson datasheets is permissible only if reproduction is without alteration and is accompanied by all associated copyright, proprietary and other notices (including this notice) and conditions. Wolfson is not liable for any unauthorised alteration of such information or for any reliance placed thereon.

Any representations made, warranties given, and/or liabilities accepted by any person which differ from those contained in this datasheet or in Wolfson's standard terms and conditions of sale, delivery and payment are made, given and/or accepted at that person's own risk. Wolfson is not liable for any such representations, warranties or liabilities or for any reliance placed thereon by any person.

ADDRESS:

Wolfson Microelectronics plc
26 Westfield Road
Edinburgh
EH11 2QB
United Kingdom

Tel :: +44 (0)131 272 7000

Fax :: +44 (0)131 272 7001

Email :: sales@wolfsonmicro.com

REVISION HISTORY

DATE	REV	ORIGINATOR	CHANGES
10/03/11	4.6	JMacD	Removal of WM8772SEFT (TQFP) references throughout datasheet.

X-ON Electronics

Largest Supplier of Electrical and Electronic Components

Click to view similar products for [Interface - CODECs](#) category:

Click to view products by [Cirrus Logic](#) manufacturer:

Other Similar products are found below :

[CS4205-KQZ](#) [ADAU1777BCBZRL](#) [LE58QL021BVCT](#) [TSCS42A2X1NLGIZAX](#) [BU92001KN-E2](#) [TLC320AD52CPT](#) [TDA7293V-E](#)
[STA529Q](#) [SSM2603CPZ-REEL](#) [TLV320AIC14IDBT](#) [TLV320AIC23BIPWRQ1](#) [TLV320AIC23IPW](#) [TLV320AIC3262IYZFR](#)
[WM8904CGEFL/RV](#) [LE58QL063HVC](#) [SSM2167-1RMZ](#) [AD1836AASZ](#) [AD1836ACSZ](#) [ADAU1381BCPZ](#) [ADAU1761BCPZ](#)
[ADAU1761BCPZ-R7](#) [ADAU1787BCBZRL7](#) [ADAV801ASTZ](#) [SSM2603CPZ-REEL7](#) [AD74111YRUZ-REEL7](#) [AD74111YRUZ](#)
[AD1928YSTZ](#) [ADAU1328BSTZ](#) [ADV212BBCZ-150](#) [AD1938WBSTZ-RL](#) [SSM2604CPZ-REEL7](#) [XD74LS42](#) [XD74LS48](#) [XD74LS47](#)
[XD74LS145](#) [XD74LS247](#) [XD74LS248](#) [PT2272-L4](#) [PT2262](#) [pt2272-m4](#) [AD2262](#) [EG201A](#) [HT12D](#) [CPC5750U](#) [GM7122](#) [GM7121-D](#)
[GM7123C](#) [CMX649E3](#) [CMX639E2](#) [MAX98050ENX+](#)