

Design Features of C&K Smart Card Connectors

C&K Components has a successful track record of manufacturing innovative interconnect devices with a strong emphasis on reliability and flexibility. As a long established supplier of such devices for Smart Cards in a wide range of applications, we have extensive experience matching performance with the need to remain cost sensitive. We consider the true cost of the interconnect to be a function not just of price, but also the ease with which the device can be integrated into the customer's production process and its performance in the field. We have built in a number of features which set our products apart, such as:

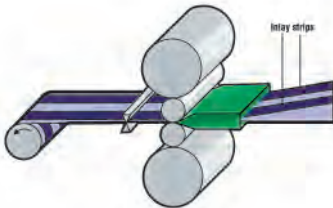

Inlay contact finish

A means of applying precious metal to the contact area utilizing pressure as opposed to conventional plating. We have found this to be the most durable finish available without compromising the electrical performance of the contact. Our research has shown that our inlay finish lasts over ten times as long as standard gold plating. Where we state the life of the precious metal this is intended to be the "worst case" scenario, because the test has been made using the most abrasive smart card that we can find on the market (given that the equipment maker can rarely control which smart cards are used). Note that the inlay finish is silver in color, being an alloy of gold, silver, and palladium.



Card detection switches

As a manufacturer of switches as well as interconnects, we have been able to integrate high performance dome switches into many of our devices. These are variants of switch products which are already in high volume production as stand alone components.



Mechanical robustness

Four metal pegs, to be soldered in PCB metalized holes at the same time than the SMT terminals, have been designed on the smart card connectors in order to increase the resistance of the connector to card insertion force. This participates to the life time and to the overload resistance.

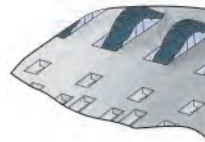

Contact design

The geometry of the contact has an important bearing on its electrical performance. Our contacts are designed to give an efficient wiping action and to maximize the stress between contact and card, thus minimizing the contact resistance. The "spooned" contact area is also shaped so as to protect it from damage during card insertion.



PCI (security standard for POS applications)

Two levels of PCI compatibility level are available:

PCI ready:

Specific features are designed in the connector in order to ease the integration of security devices around and below the connector.

PCI:





Additional accessories are integrated on the connector in order to avoid access to the data contacts and to detect any connection attempt.

Materials

The contact material has been chosen because of its resistance to atmospheric pollution, solderability and performance over time in giving a consistent normal force. Since all of our new interconnects are designed for surface mounting, the plastic materials used must withstand high temperature soldering processes without deforming or adversely affecting performance.



FULL SIZE CARD CONNECTORS

				
Series	CCM01	CCM02	CCM04	
Applications	Professional	Professional	Consumer/Professional	
PCI*	PCI ready	PCI/PCI ready		
EMV	•	•		
Insertion force	40N max	40N max	10N max	
Overload	250N	180N	40N	
Card guide	•	•		
Sealed switch	•	•		
Operating life	100,000 cycles	500,000 cycles	>50,000 cycles	
Contact plating	inlay	inlay	gold	
Number of contacts	8	8	6 or 8	
Contact type	friction	friction	friction/vandal proof	
Page No.	7	12	17	

SIM / SAM CARD CONNECTORS

			
Series	CCM03	CCM04	
Applications	Consumer/Professional	Consumer/Professional	
Cover	hinged / fixed	hinged / fixed	
Operating life	10,000 to 50,000 cycles	30,000 cycles	
Sealed switch	•		
Contact plating	inlay / gold	inlay / gold	
Card end travel switch	with / without	without	
Number of contacts	6 or 8	6 or 8	
Page No.	24	43	

* PCI

PCI ready: specific features are designed into the connector in order to ease the integration of security devices around and below the connector.

PCI: specific additional accessories are integrated on the connector in order to avoid access to the data contacts and to detect any connection attempt.

The logo for C&K, featuring the letters 'C' and 'K' in a bold, red, italicized font, with an ampersand '&' in a smaller, black font between them. A registered trademark symbol (®) is located at the top right of the 'K'.

C&K®

Full Size Cards



Features

- Operating life up to 100,000 cycles
- 40N card insertion force
- EMV
- PCI ready
- Card detection sealed switch

Typical Applications

- Transaction
- Identification
- POS



Mechanical

Number of Contacts	8
Mechanical life	Up to 500,000 cycles
Card insertion force	40N max.
Card extraction force	1 N min / 10 N max
Contact force	0,2N / 0,50 N max
Card detection switch	0,8 N max for actuation (end travel switch actuation force actuates when card is 0,9mm from card stop)
	1,8 N max for complete depression
Vibration Frequency	10 to 500 Hz. Acceleration 50m/s ² Duration 6 hours - amplitude 0,35mm
Max elect. discontinuity	1µs
Shock	Peak value 500 m/s ² – Duration 11 ms 3 shocks in each direction of each axis

Packaging

Tray 30 parts / Cartons 300 parts
Reel 200 parts / Cartons 1,000 parts

Soldering

Compatible with lead free SMT reflow soldering process

Contact Electrical Data

Insulation resistance	1,000 MΩ min
Resistance	100 mΩ max
Current rating	10 µA min / 1 A max
Dielectric strength	750 Vrms min

Switch Electrical Data

Card detection switch	Normally open
Contact resistance	100 mΩ max
Dielectric strength	250 Vrms min
Current rating	1 mA min / 10 mA max
Maximum power	0.2 VA

Environmental Data

Operating temperature	-40°C to +85°C
Damp heat	IEC 512 test number 11c (10 days)
Salt mist	IEC 512 test number 11f (96 hours)
Card detection switch	Sealed against dust
RoHS compliant	

Designation	Termination	Operating Life	Card Insertion Force
CCM01-2027LFT	SMT	100,000 cycles	40N

CCM01 MK2 Series

CCM01-2027 LFT

Full Size

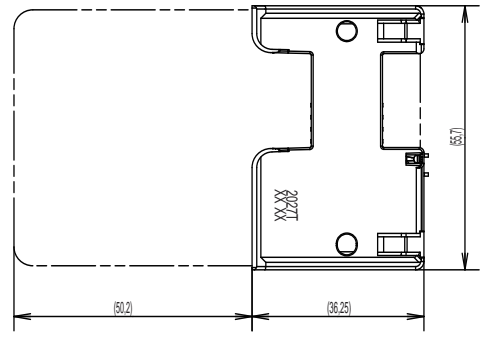
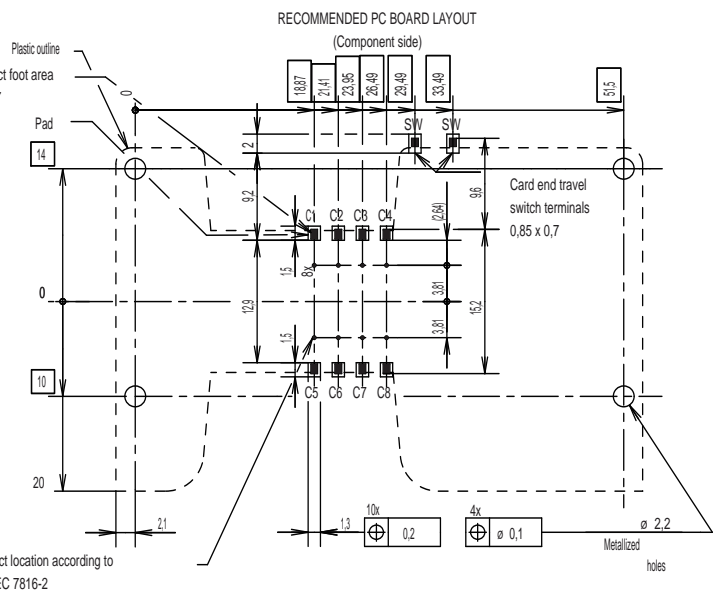
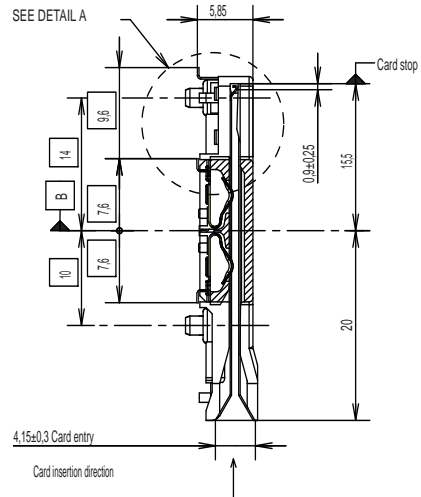
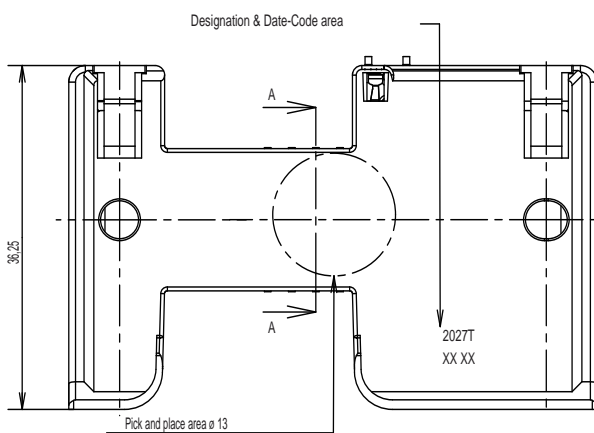
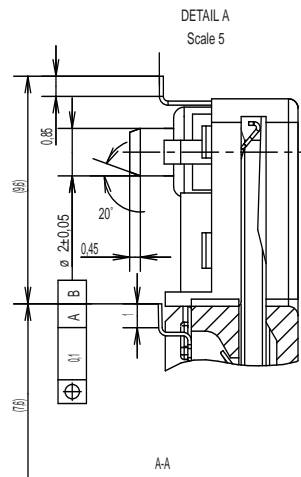
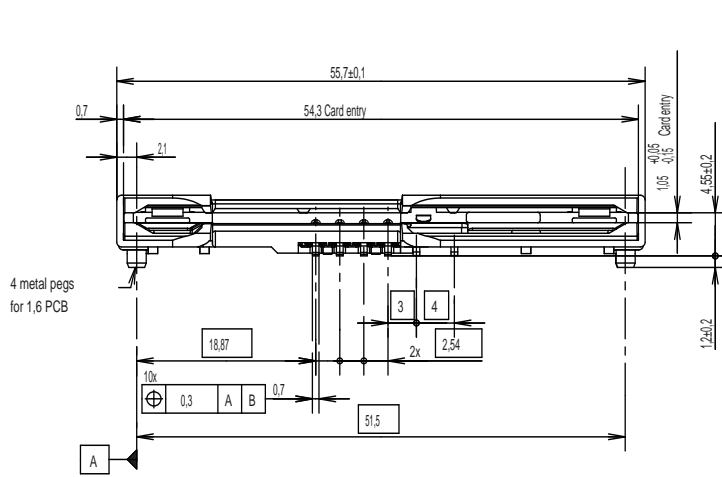

Dimensions are shown in mm
Specifications and dimensions subject to change

www.ck-components.com

Features/Benefits

- Operating life 500,000 cycles
- Low profile 4 mm and 3.2 mm height
- PCI ready
- Card detection sealed switch

Typical Applications

- Transaction
- Identification
- POS
- MPOS



Full Size

Mechanical

NUMBER OF CONTACTS:	8
MECHANICAL LIFE:	500,000 cycles
CARD INSERTION FORCE:	10 N max.
CARD EXTRACTION FORCE:	1 N min. / 10 N max.
CONTACT FORCE:	0,2 N / 0,60 N max.

Packaging

Tray 25 parts or Reel 350 parts

Soldering

Compatible with lead free SMT reflow soldering process

Contact Electrical Data

INSULATION RESISTANCE:	1,000 M Ω min.
CONTACT RESISTANCE:	100 m Ω max.
CURRENT RATING:	10 μ A min. / 1A max.
DIELECTRIC STRENGTH:	750 Vrms min.

Switch Electrical Data

CARD DETECTION SWITCH:	Normally open
CONTACT RESISTANCE:	100 m Ω max.
DIELECTRIC STRENGTH:	250 Vrms min.
CURRENT RATING:	1 mA min. / 10 mA max.
MAXIMUM POWER:	0.2 VA

Environmental Data

OPERATING TEMPERATURE:	-40°C to + 85°C
CARD DETECTION SWITCH:	Sealed against dust
RoHS compliant	

How To Order

To order, simply select desired option from each category and place in the appropriate box. For additional options not shown in catalog, consult our Customer Service Center.

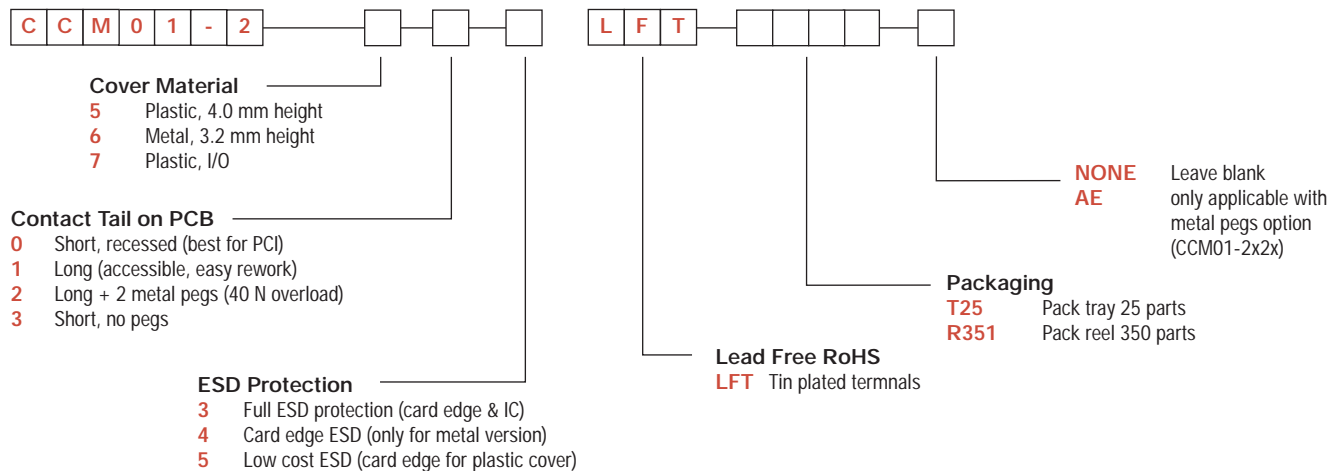

Dimensions are shown in mm
Specifications and dimensions subject to change

www.ck-components.com

CCM01 MK5 Series

CCM01-2604 LFT T25 Metal cover, short tails

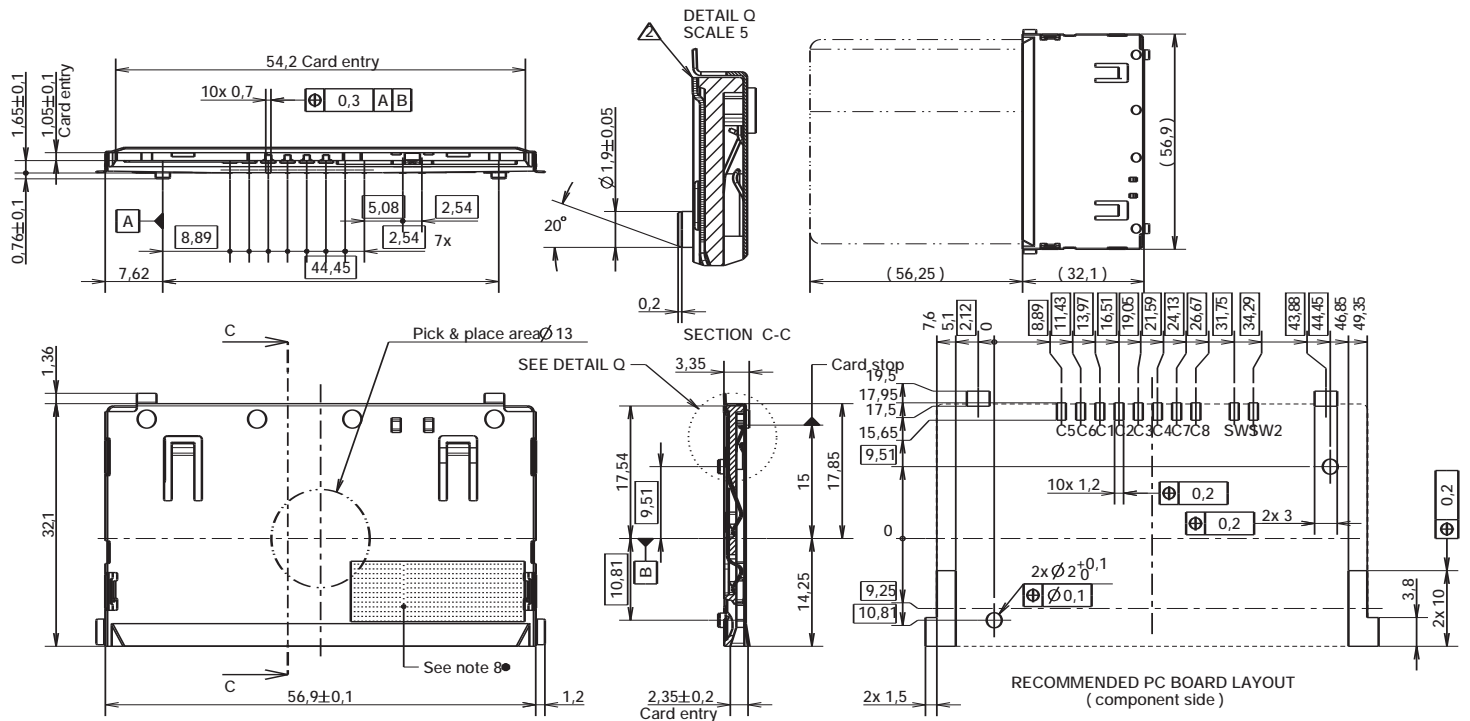

CCM01-2513 LFT T25 Plastic cover, long tails, full ESD protection

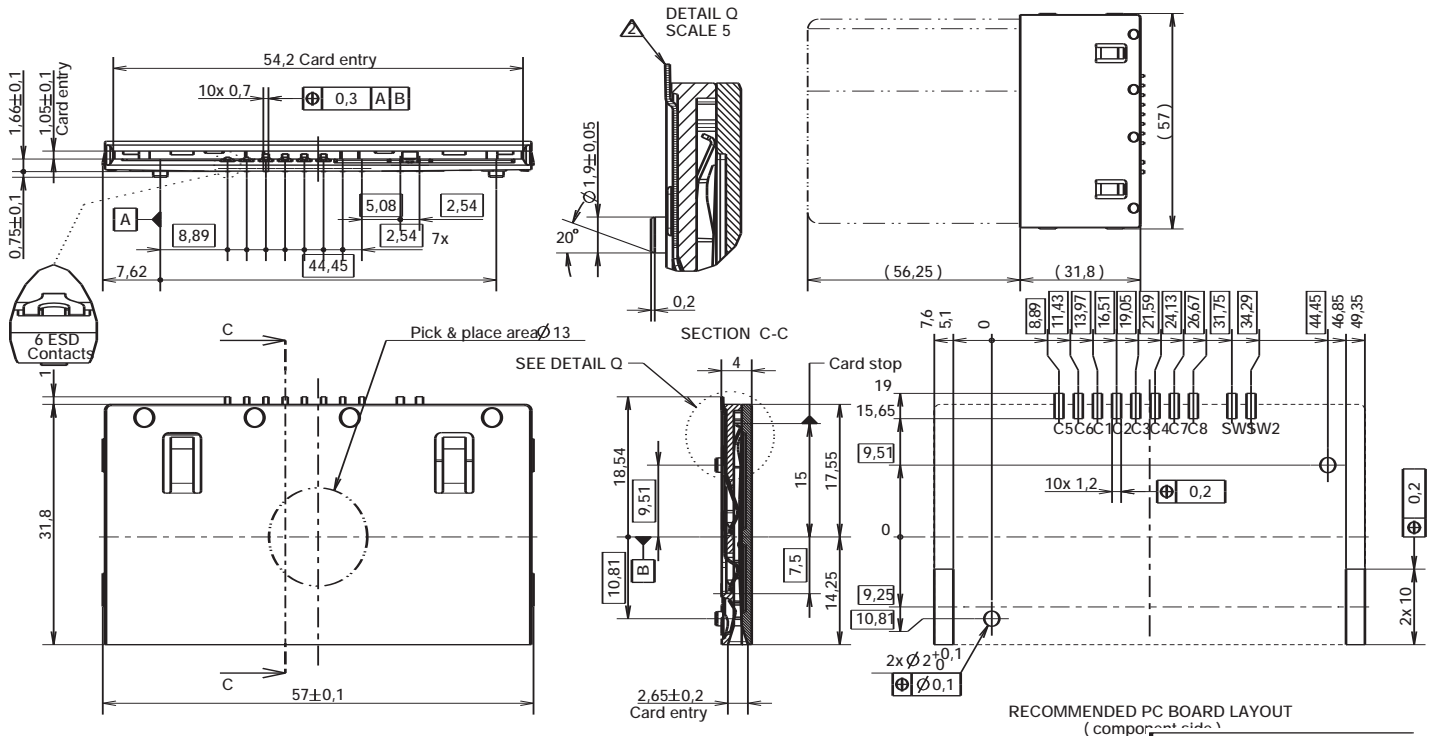

Dimensions are shown in mm
Specifications and dimensions subject to change

www.ck-components.com

CCM01 MK5 Series

CCM01-2523 LFT T25 Plastic cover, long tails, metal pegs

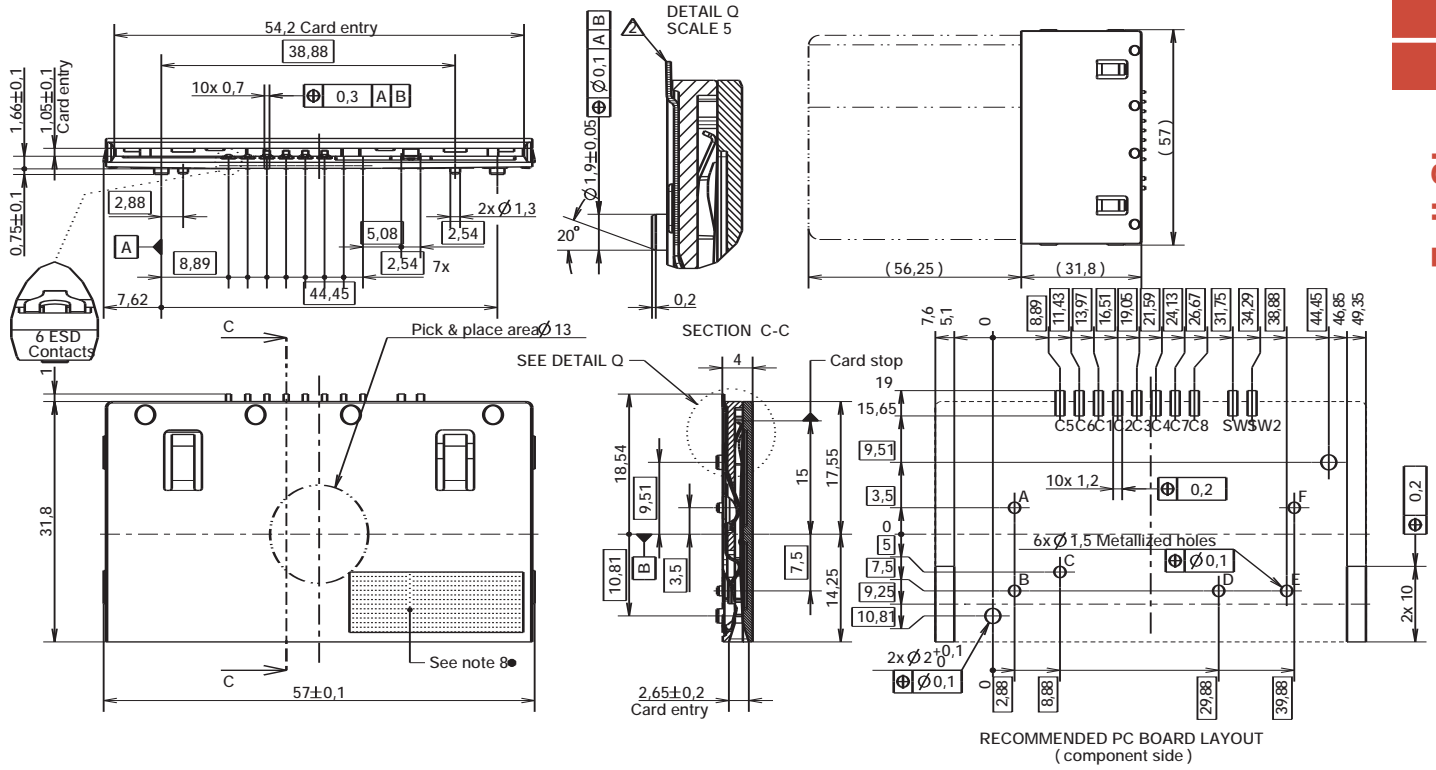

Full Size

CCM01-2614 LFT T25 Metal cover, long tails, no ESD protection

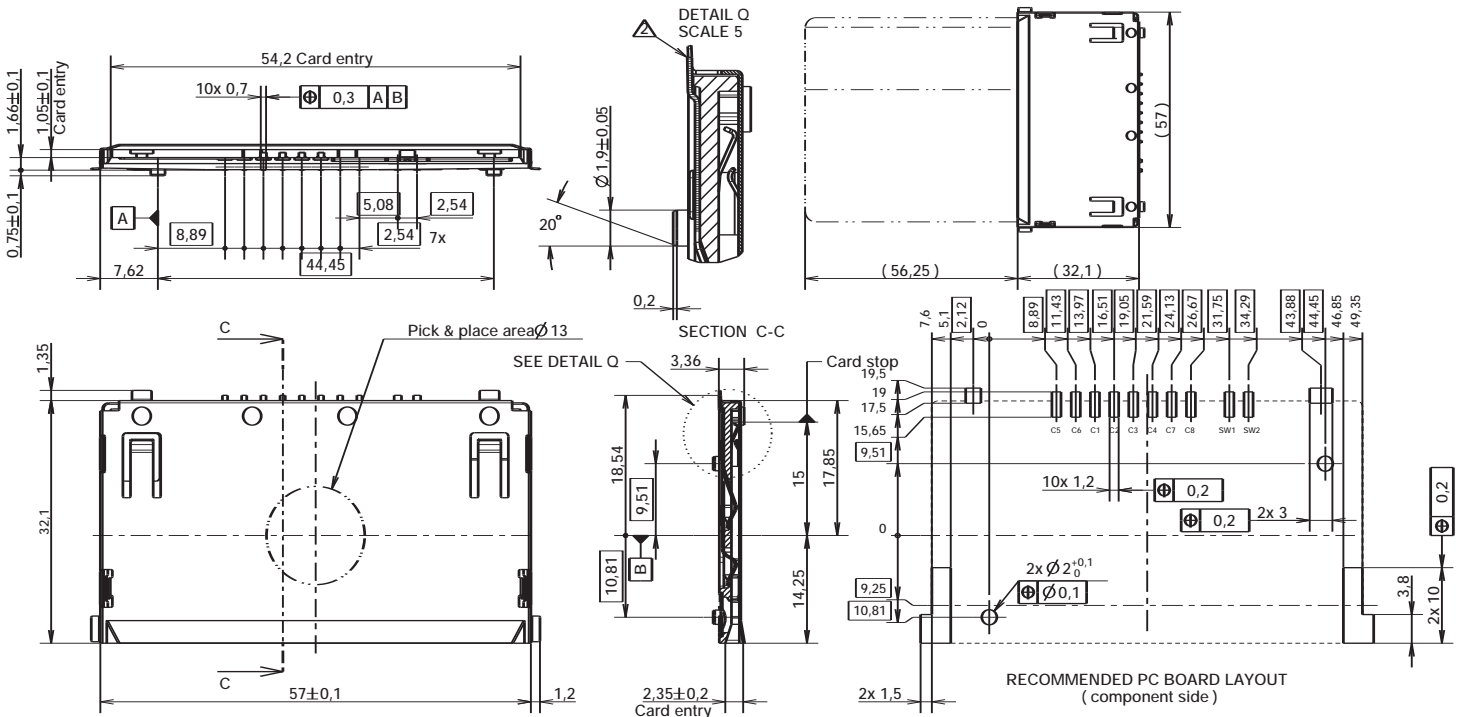

Dimensions are shown in mm
Specifications and dimensions subject to change

www.ck-components.com

CCM02 MK2 Series



Features

- Operating life 500,000 cycles
- Insertion force 40N
- EMV
- PCI & PCI ready
- Card detection sealed switch

Typical Applications

- Transaction
- Identification
- POS

Mechanical

Number of Contacts	8
Mechanical life	500,000 cycles min
Card insertion force	10N to 40N
Card extraction force	1N min / 10N max
Contact force	0,2N / 0,50N max
Card detection switch	0,8 N max for actuation (end travel switch actuation force actuates when card is 0,9mm from card stop) 1,8 N max for complete depression
Vibration Frequency	10 to 500 Hz. Acceleration 50m/s ² Duration 6 hours - amplitude 0,35mm
Max elect. discontinuity	1µs
Shock	Peak value 500 m/s ² – Duration 11 ms 3 shocks in each direction of each axis

Packaging

Tray 30 parts / Cartons 300 parts
Reel 120 parts

Soldering

Compatible with lead free reflow soldering process
For version with security cover, please contact Customer Service for soldering recommendations.

Contact Electrical Data

Insulation resistance	1,000 MΩ min
Resistance	100 mΩ max
Current rating	10 µA min / 1 A max
Dielectric strength	750 Vrms min

Switch Electrical Data

Card detection switch	Normally open
Contact resistance	100 mΩ max
Dielectric strength	250 Vrms min
Current rating	1 mA min / 10 mA max
Maximum power	0.2 VA

Environmental Data

Operating temperature	-40°C to +85°C
Damp heat	IEC 512 test number 11c (10 days)
Salt mist	IEC 512 test number 11f (96 hours)
Card detection switch	Sealed against dust
RoHS compliant	

Designation	Termination	Contact Type	PCI Features		Total Height (mm)	Dimension	PCB version
			I/O Protect	Security Cover			
CCM02-2503LFT	THT	landing			6,25	38,5 X 55,6	4 clips
CCM02-2504LFT	SMT	landing			6,25	38,5 X 55,6	4 clips
CCM02-F503LFT	THT	friction			6,25	38,5 X 55,6	4 clips
CCM02-F504LFT	SMT	friction			6,25	38,5 X 55,6	4 clips
CCM02-F844LFT	SMT	friction	Yes	Yes	6,6	40,5 X 58	4 metal pegs

PCI: I/O Protect

Definition

Special accessory in order to avoid and detect frontal access to data contact. It is electrically connected to the PCB through spring finger contacts.

Process

It must be in open position during the reflow soldering of the connector and has to be locked in closed position after soldering.



I/O Protect locking tool

C&K is proposing a manual tool to lock the I/O protect accessory after soldering.
Ordering code: C-CM02-E50

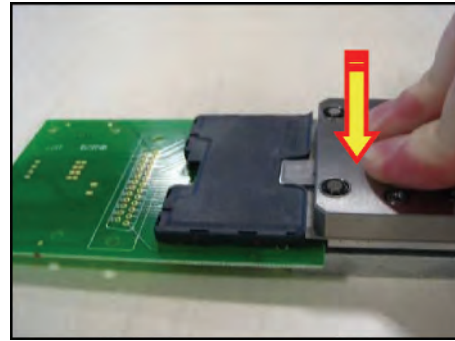
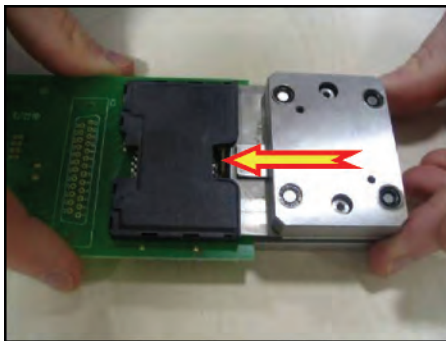

PCI: Security Cover



Definition

It is a multilayer cover placed over the connector to avoid and detect data contact access, especially from the top. It is connected to the PCB through 6 SMT terminals that are soldered at the same time as the other smart card terminals.

Process

Please contact your Sales Representative for advice and recommendations about soldering this version.

CCM02 MK2 Series

CCM02-2503 LFT / CCM02-F503 LFT

Full Size

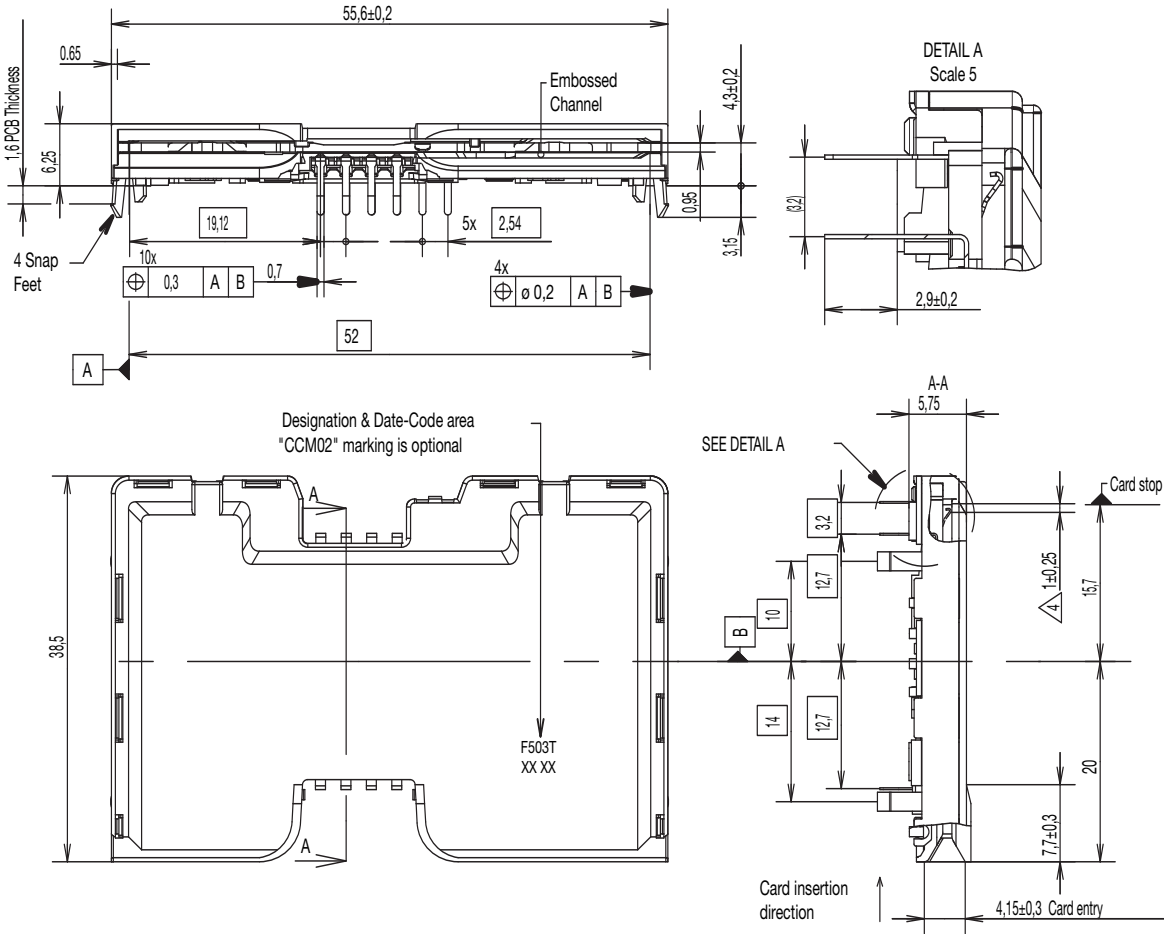

RECOMMENDED PC BOARD LAYOUT
(Component side)

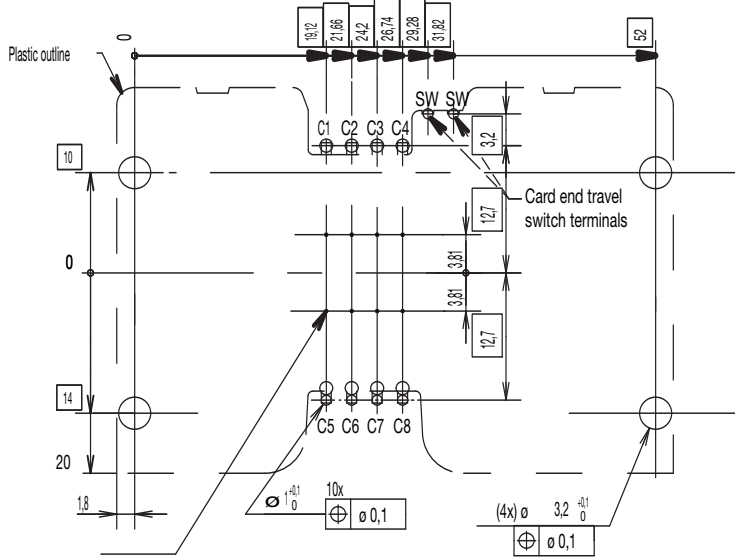

Contact location according to ISO/IEC 7816-2

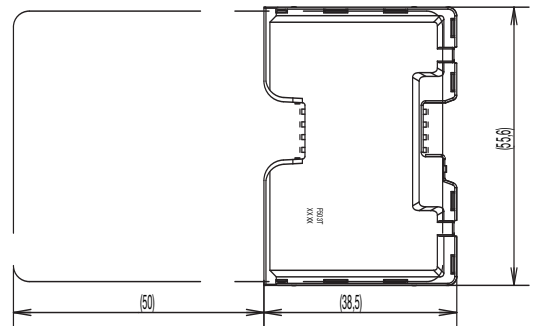

First Angle Projection

Dimensions are shown in mm
Specifications and dimensions subject to change

www.ck-components.com



CCM02 MK2 Series

CCM02-2504 LFT / CCM02-F504 LFT

Full Size

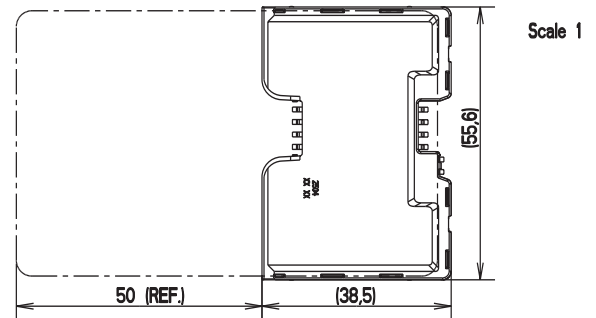
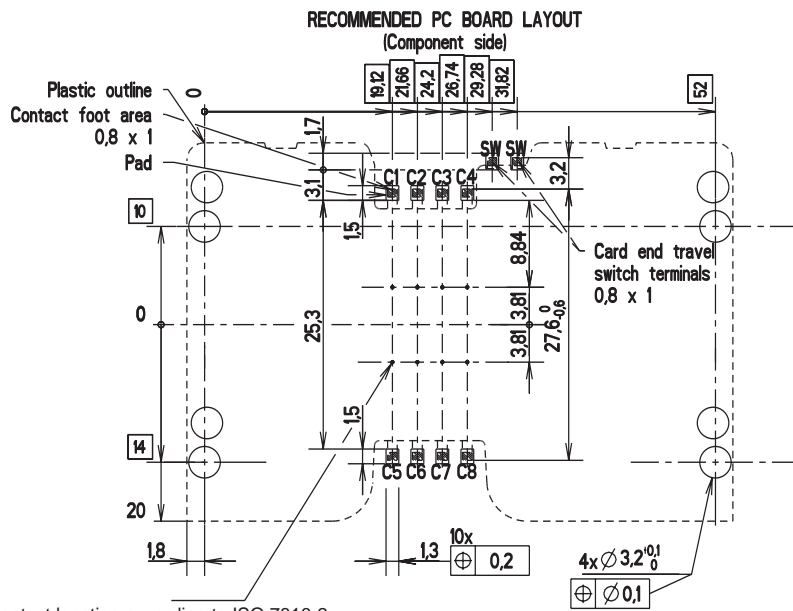
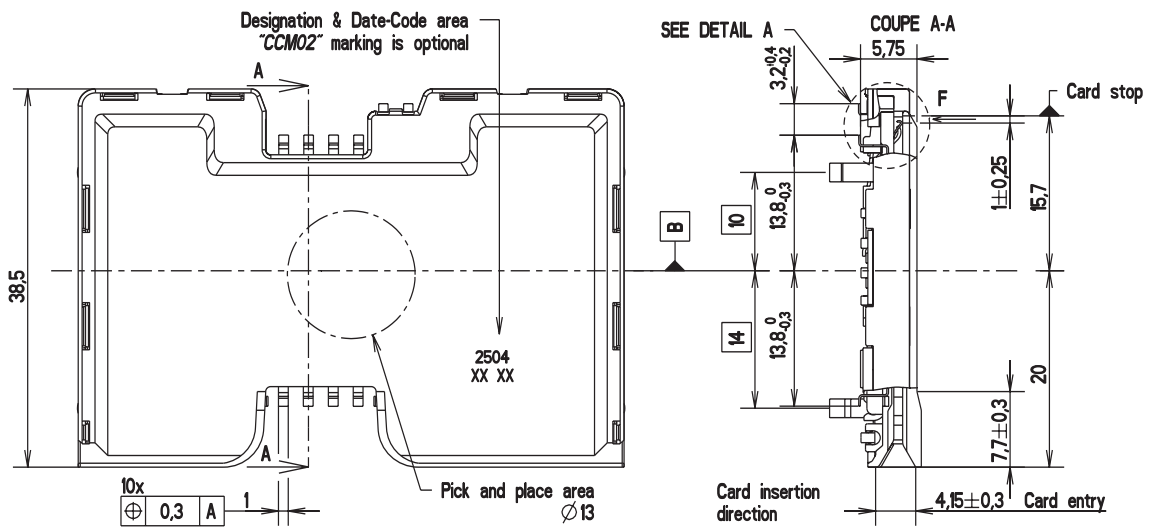
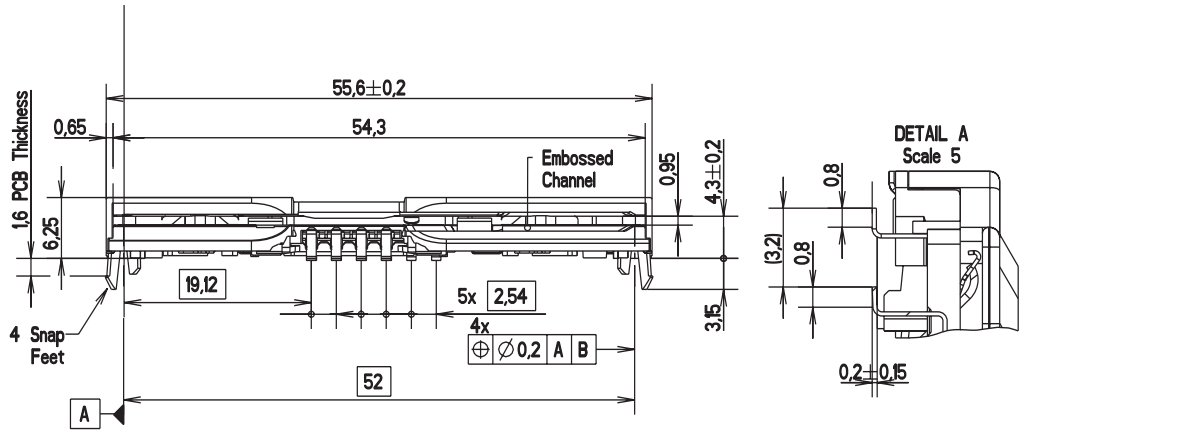

Contact location according to ISO 7816-2



Dimensions are shown in mm
Specifications and dimensions subject to change

www.ck-components.com

CCM02 MK2 Series

CCM02-F844A LFT / CCM02-F844B LFT

Full Size

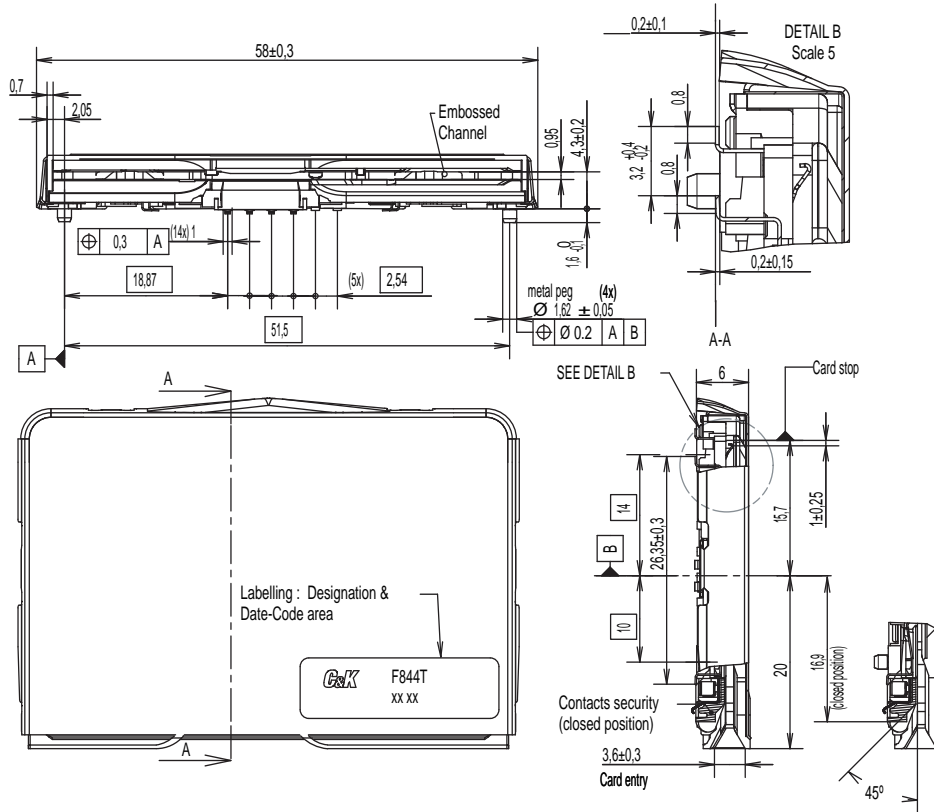

RECOMMENDED PC BOARD LAYOUT
(Component side)

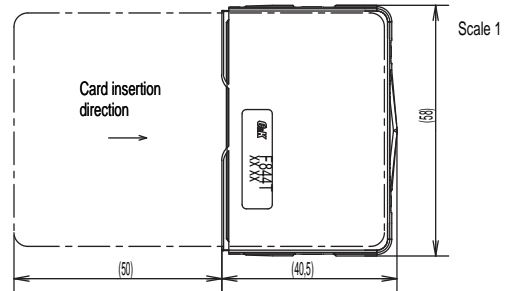
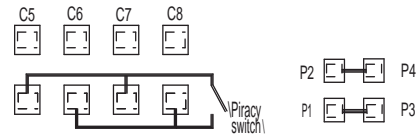
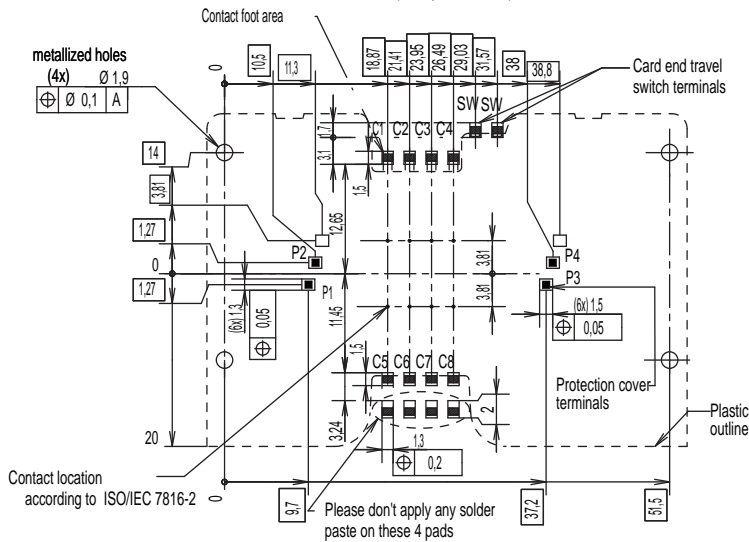

Dimensions are shown in mm
Specifications and dimensions subject to change

www.ck-components.com

Features

- ID1 full size card acceptance
- Card detection sealed switch
- Compatible with pick and place and lead free soldering

Typical Applications

- Transaction
- POS
- Identification



Mechanical

Number of contacts	6 or 8
Mechanical life	50,000 cycles
Card insertion force	10N max
Card extraction force	1N min / 10N max
Contact force	0,4N to 0,7N
Card detection switch	0,8 N max for actuation (end travel switch actuation force actuates when card is 0,9mm from card stop)
	1,8 N max for complete depression
Vibration Frequency	10 to 500 Hz. Acceleration 50m/s ² Duration 6 hours - amplitude 0,35mm
Shock	Peak value 500 m/s ² – Duration 11 ms 3 shocks in each direction of each axis
Max elect. discontinuity	1µs

Packaging

See table below

Soldering Process

Compatible with lead free SMT reflow soldering process

Contact Electrical Data

Insulation resistance	1000 MΩ min
Contact resistance max	100 mΩ max
Switching current	10 µA min / 1 A max
Dielectric strength	750 Vrms min

Switch Electrical Data

Card detection switch	Normally open
Rc card detection switch	100 mΩ max
Dielectric strength	250 Vrms min
Switch current rating	1 mA min / 10 mA max
Maximum switch power	0.2 VA

Environmental Data

Operating temperature	-40°C to +85°C
Salt mist	IEC 512 test number 11f (96 hours)
Damp heat	IEC 512 test number 11c (10 days)
Card detection switch	Sealed against dust
RoHS compliant	

Designation	Housing Type	# of Contacts	Contact Force	Total Height (mm)	Total Dim. (mm)	Packaging
CCM04-5427LFT	standard	8	0,4N to 0,7N	2,65	18,75 X 25	reels of 1,000 pcs
CCM04-5436LFT	standard	8	0,4N to 0,7N	0,90	18,75 X 26,9	reels of 1,000 pcs
CCM04-5468LFT	stand-off	8	0,4N to 0,7N	3,5	18,75 X 24	reels of 1,000 pcs
CCM04-5454LFT	standard	8	0,4N to 0,7N	0,90	18,75 X 26,9	reels of 1,000 pcs
CCM04-5455LFT	standard	8	0,4N to 0,7N	0,90	18,75 X 26,9	reels of 1,000 pcs

CCM04 MK4 Series

CCM04-5436 LFT

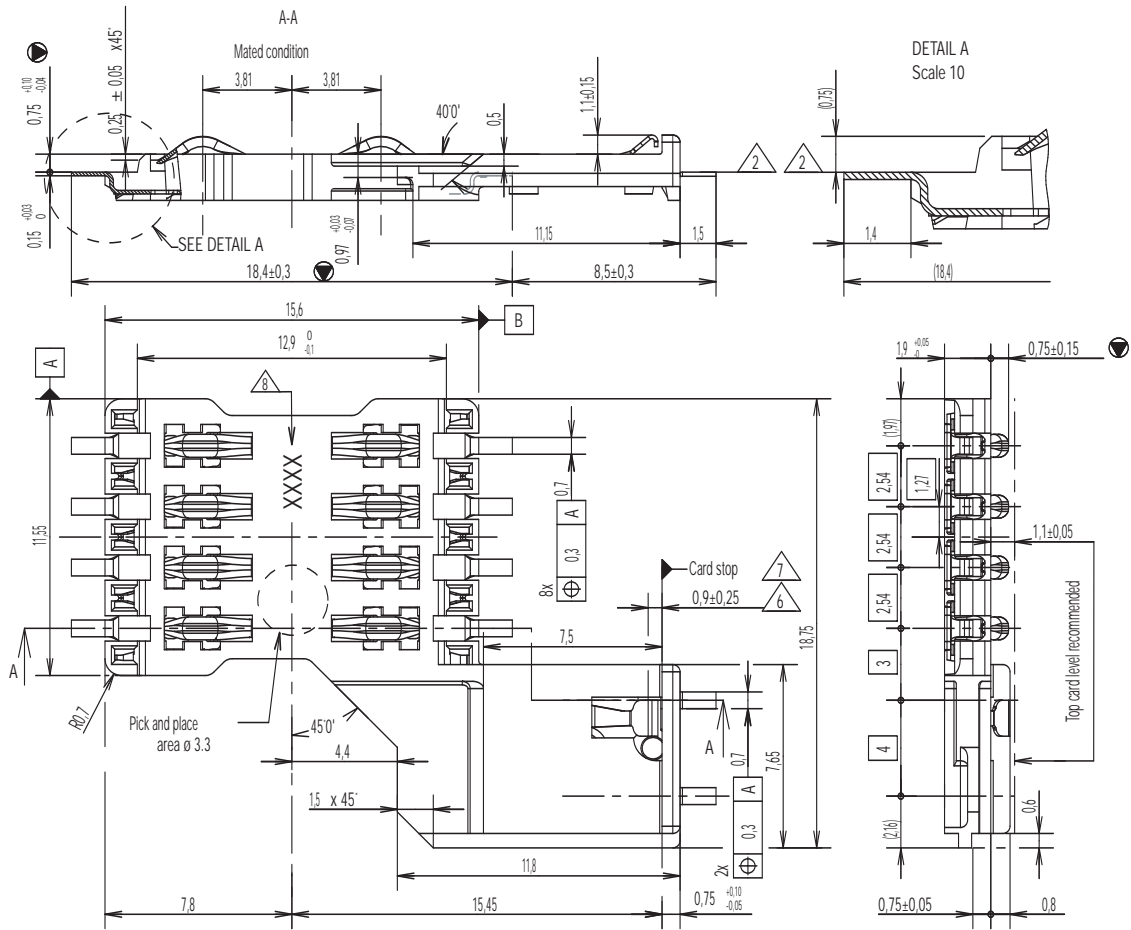

RECOMMENDED PC BOARD LAYOUT
(Component side)

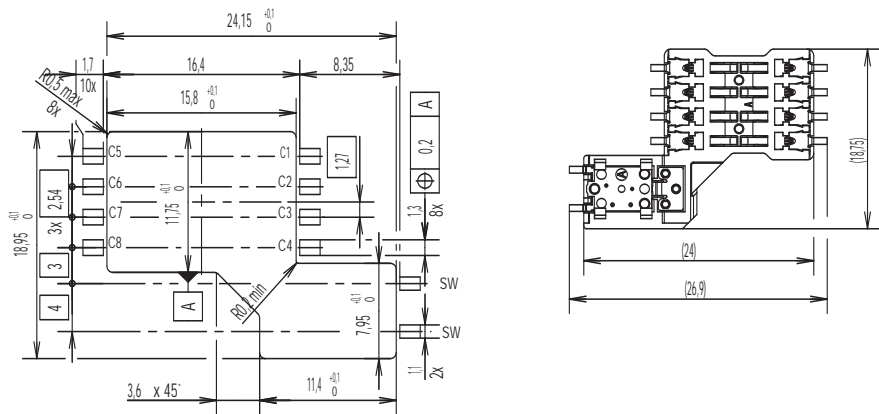

Dimensions are shown in mm
Specifications and dimensions subject to change

www.ck-components.com

Full Size

CCM04 MK4 Series

CCM04-5454 LFT

Full Size

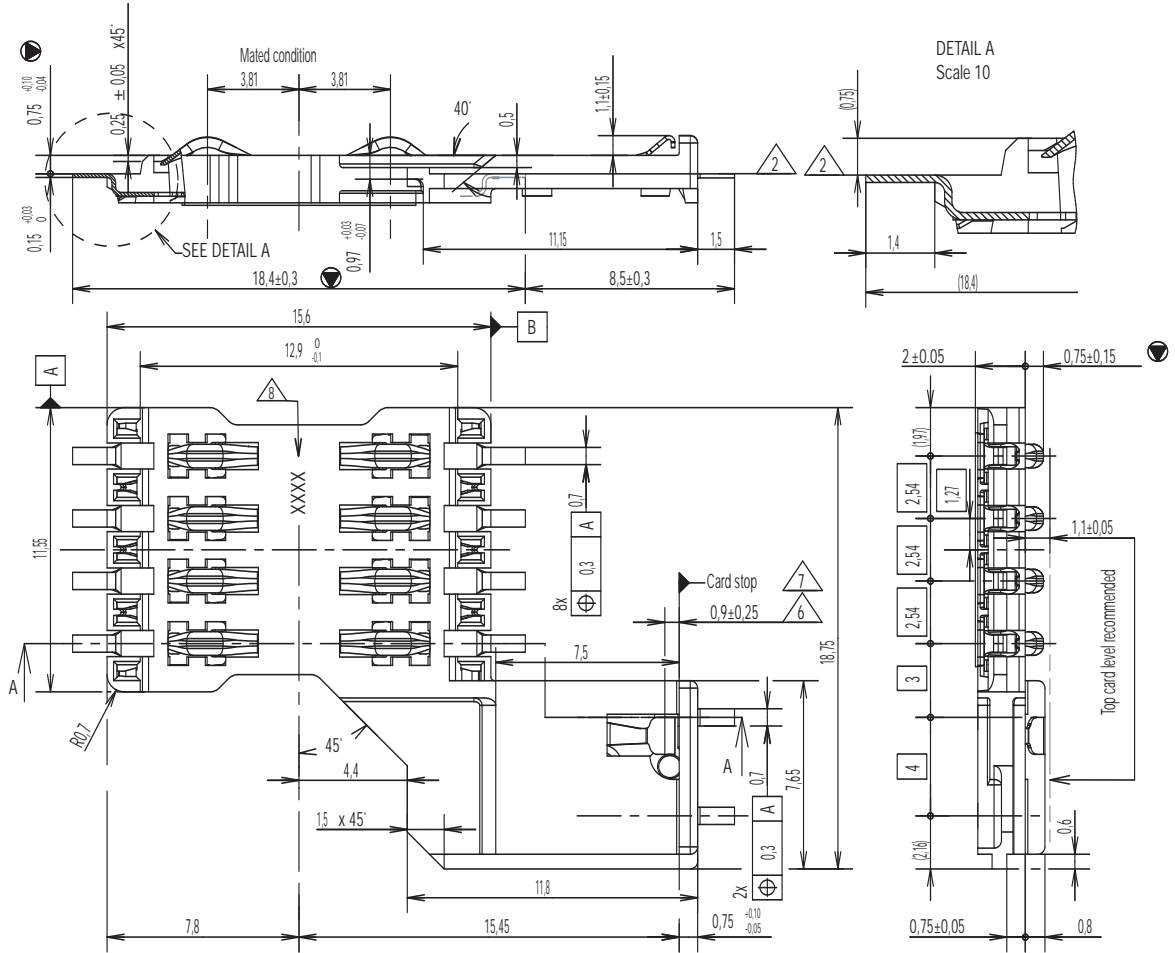

RECOMMENDED PC BOARD LAYOUT
(Component side)
Scale 2,5

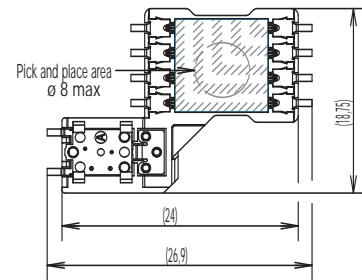
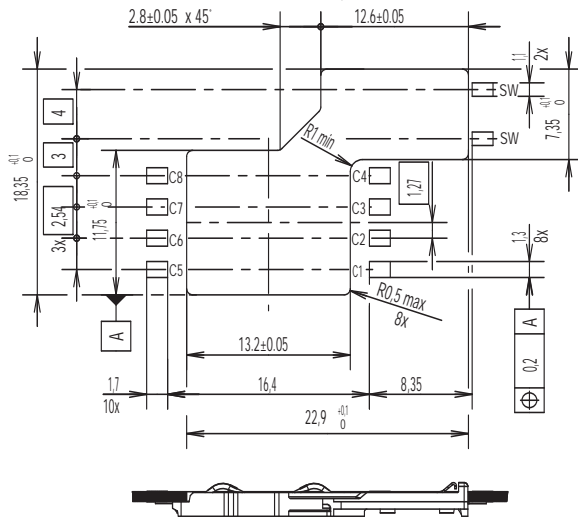

Dimensions are shown in mm
Specifications and dimensions subject to change

www.ck-components.com

CCM04 MK4 Series

CCM04-5455 LFT

Full Size

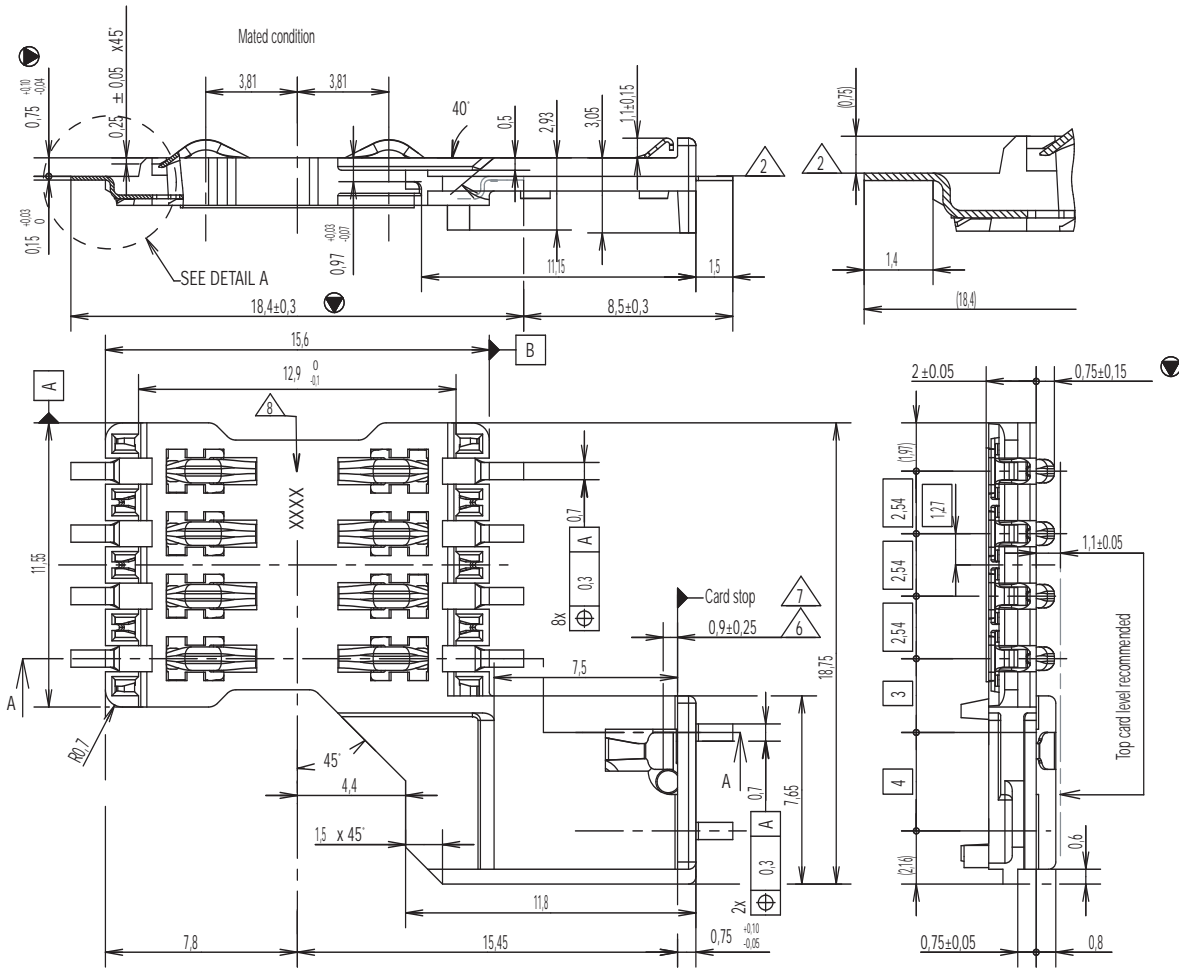

RECOMMENDED PC BOARD LAYOUT
(Component side)
Scale 2,5

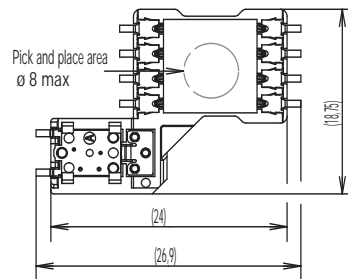
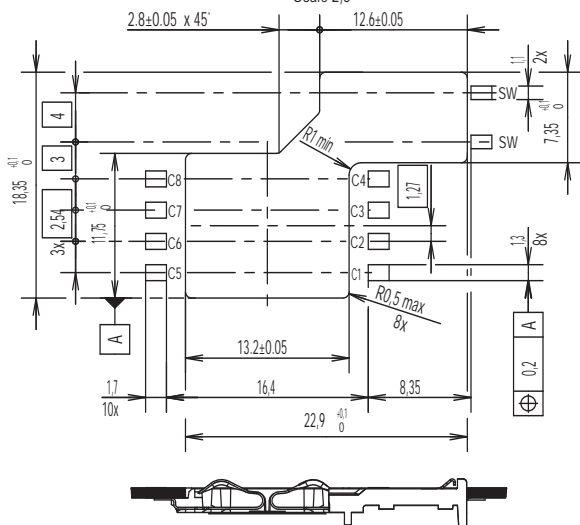

First Angle Projection

Dimensions are shown in mm
Specifications and dimensions subject to change

www.ck-components.com



The logo for C&K, featuring the letters 'C' and 'K' in a bold, red, italicized font, with an ampersand '&' in black between them. A registered trademark symbol (®) is located at the top right of the 'K'.

C&K

A red horizontal bar containing the text 'SIM / SAM Cards' in white, bold, sans-serif font.

SIM / SAM Cards



CCM03 MK2 Series



Features

- SIM/SAM card acceptance
- Hinged and fixed covers
- Compatible with pick and place and lead free soldering

Typical Applications

- Handheld products
- Identification
- POS
- Automotive

Mechanical

Number of Contacts	6 or 8
Mechanical life, hinged cover	10,000 cycles min
Mechanical life, fixed cover	50,000 cycles
Card insertion force	Hinged cover: 1N max Fixed cover: 3N max
Card extraction force	Hinged cover: 1N max Fixed cover: 0,80N min / 3N max
Contact force	0,25N min / 0,50N max
Slide locking force	2N min / 6N max 1,8N max. for complete depression
Vibration Frequency	10 to 500 Hz. Acceleration 50m/s ² Duration 6 hours - amplitude 0,35 mm
Max electrical discontinuity	1µs
Shock	Peak value 500 m/s ² – Duration 11 ms 3 shocks in each direction of each axis

Switch Electrical Data

Card detection switch	Normally open
Contact resistance	100 mΩ max
Dielectric strength	250 Vrms min
Current rating	1 mA min / 10m A max
Maximum power	0.2 VA

Environment Data

Operating temperature	-40°C to +85°C
Damp heat	IEC 512 test number 11c (10 days)
Salt mist	IEC 512 test number 11f (96 hours)
RoHS compliant	

Soldering Process

Compatible with lead free SMT soldering process



Contact Electrical Data

Insulation resistance	1,000 MΩ min
Resistance	100 mΩ max
Current rating	10 µA min / 1 A max
Dielectric strength	750 Vrms min

Designation	Contact Plating	Cover	# of Contacts	PCB Version	Card Presence Switch	Operating Life	Total Height (mm)	Dim. (mm)	Packaging
CCM03-3001LFT	inlay	hinged	6		without	10,000	2,55	17,2 x 29,65	reels of 1,000 pcs
CCM03-3002LFT	inlay	hinged	6	2 plastic pegs	without	10,000	2,55	17,2 x 29,65	reels of 1,000 pcs
CCM03-3003LFT	inlay	hinged	8		without	10,000	2,55	17,2 x 29,65	reels of 1,000 pcs
CCM03-3004LFT	inlay	hinged	8	2 plastic pegs	without	10,000	2,55	17,2 x 29,65	reels of 1,000 pcs
CCM03-3009LFT	gold	hinged	6		without	10,000	2,55	17,2 x 29,65	reels of 1,000 pcs
CCM03-3010LFT	gold	hinged	6	2 plastic pegs	without	10,000	2,55	17,2 x 29,65	reels of 1,000 pcs
CCM03-3011LFT	gold	hinged	8		without	10,000	2,55	17,2 x 29,65	reels of 1,000 pcs
CCM03-3012LFT	gold	hinged	8	2 plastic pegs	without	10,000	2,55	17,2 x 29,65	reels of 1,000 pcs
CCM03-3013LFT	gold	hinged	6		with	10,000	2,55	17,2 x 29,65	reels of 1,000 pcs
CCM03-3512LFT	gold	hinged	6	Large soldering pads*	without	10,000	2,55	17,2 x 29,65	reels of 1,000 pcs
CCM03-3504LFT	gold	fixed	8		without	50,000	2,85	17,2 x 25,5	reels of 1,000 pcs
CCM03-3505LFT	gold	fixed	6		without	50,000	2,85	17,2 x 25,5	reels of 1,000 pcs
CCM03-3754LFT	inlay	fixed	6		with	10,000	3,5	16,5 x 18,05	reels of 1,000 pcs
CCM03-3760LFT	inlay	fixed	6		without	10,000	3,45	16,5 x 15,85	reels of 1,000 pcs
CCM03-3764LFT	inlay	none	6		with	10,000	2,9	16,5 x 15,85	reels of 1,000 pcs

* Can go through reflow upside down

CCM03 MK2 Series

CCM03-3001 LFT / CCM03-3009 LFT

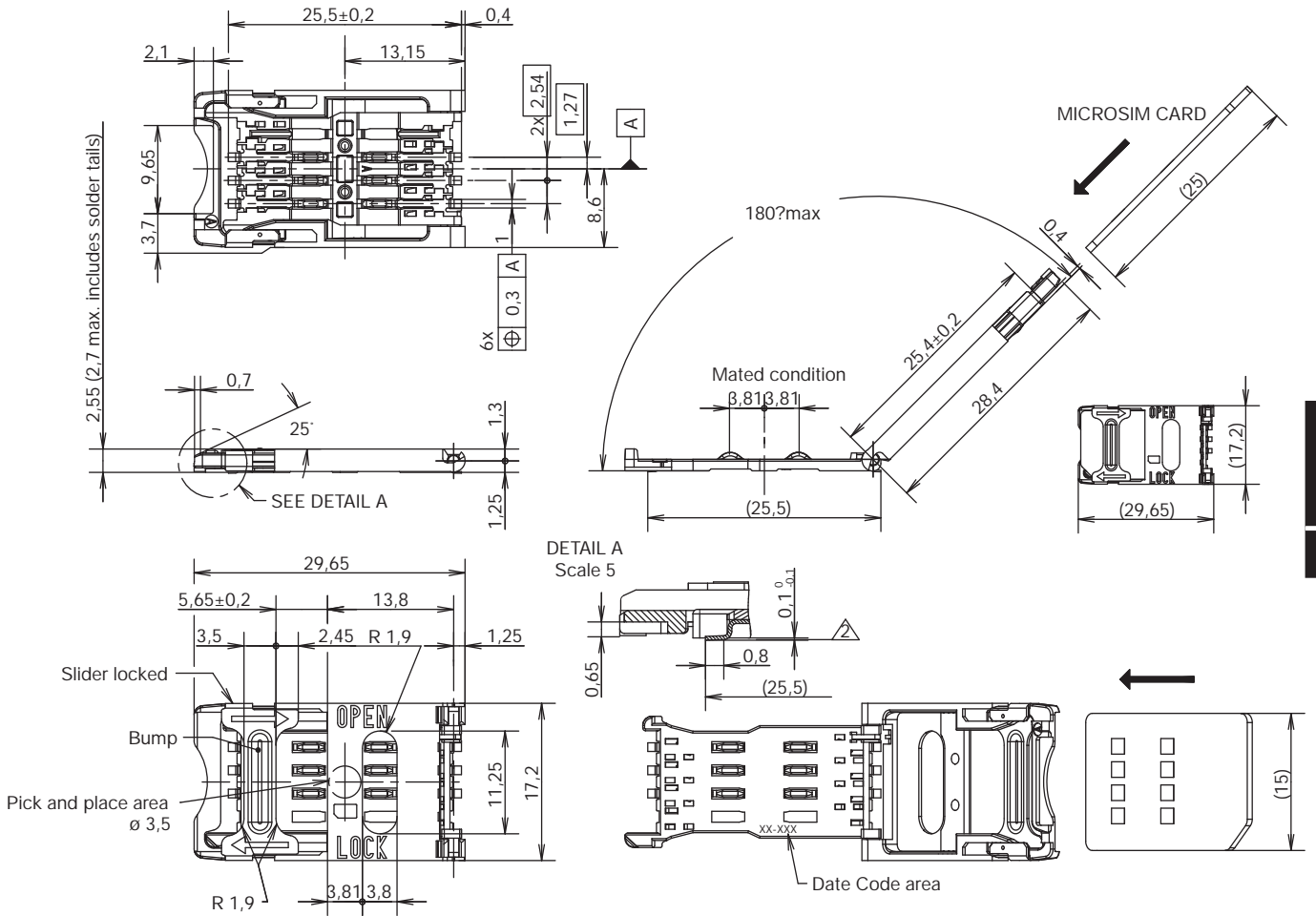

RECOMMENDED PC BOARD LAYOUT
(Component side)

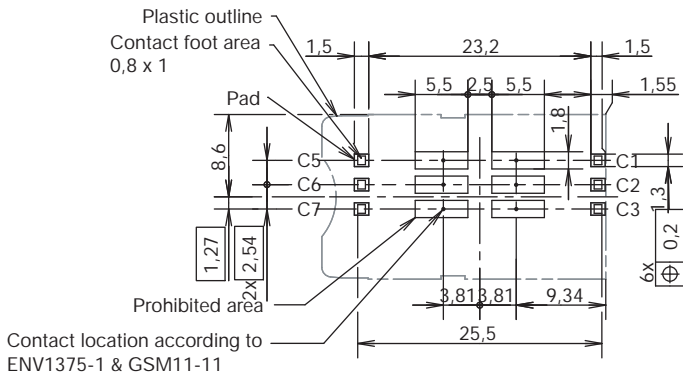

Dimensions are shown in mm
Specifications and dimensions subject to change

www.ck-components.com

CCM03 MK2 Series

CCM03-3002 LFT / CCM03-3010 LFT

SIM/SAM

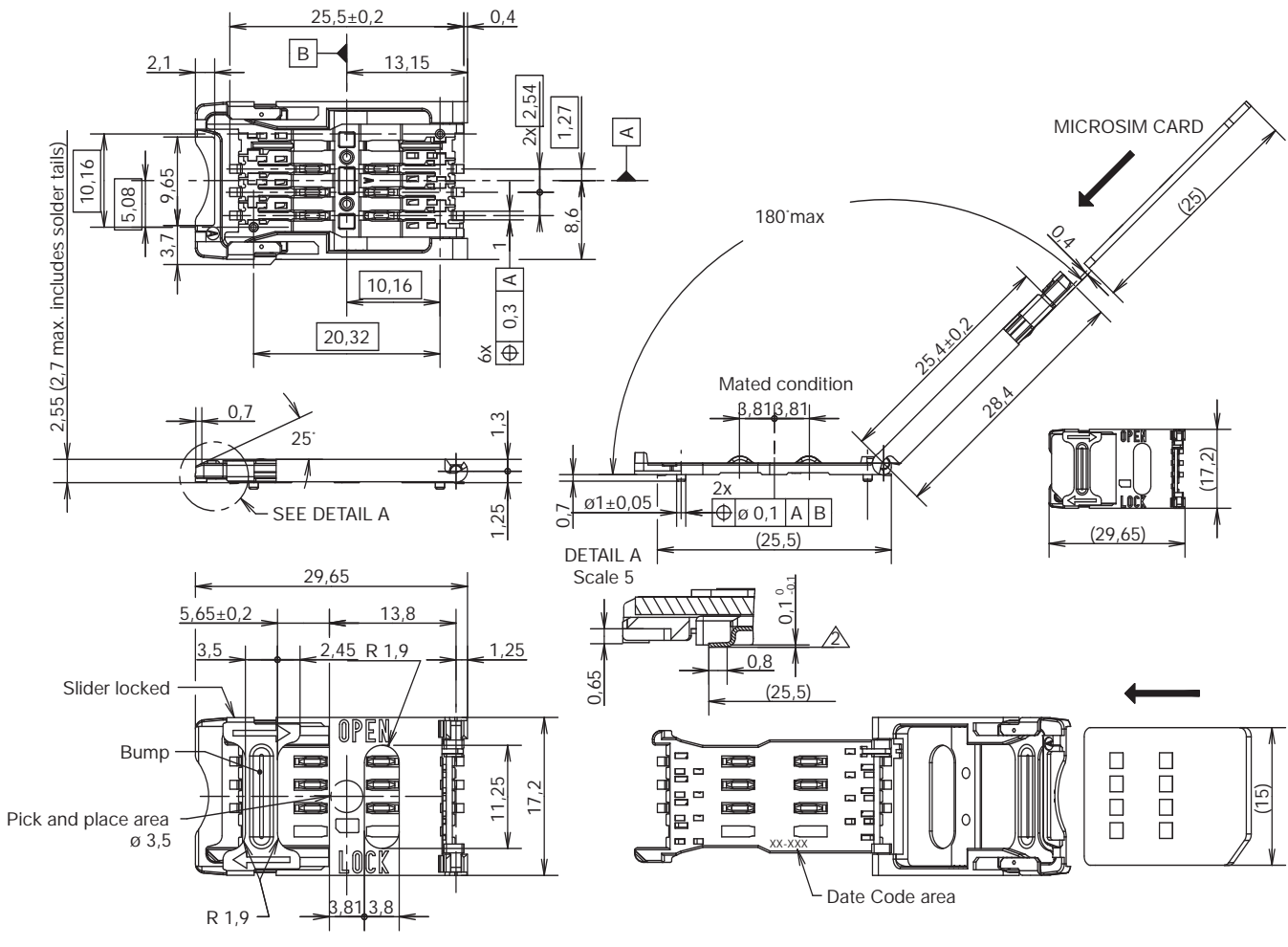

RECOMMENDED PC BOARD LAYOUT (Component side)



Dimensions are shown in mm
Specifications and dimensions subject to change



CCM03 MK2 Series

CCM03-3003 LFT

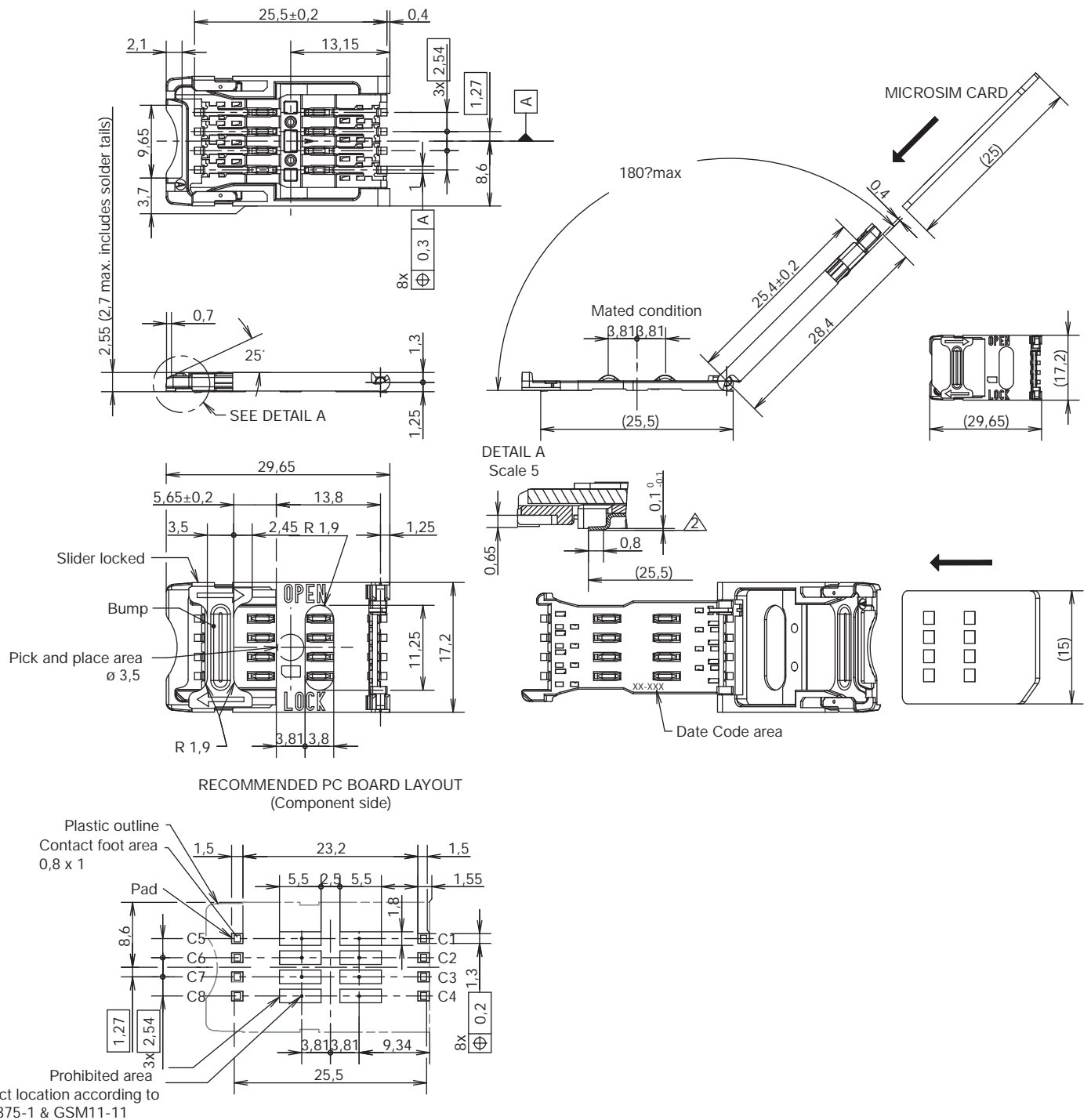

SIM/SAM



Dimensions are shown in mm
Specifications and dimensions subject to change

www.ck-components.com

CCM03 MK2 Series

CCM03-3004 LFT

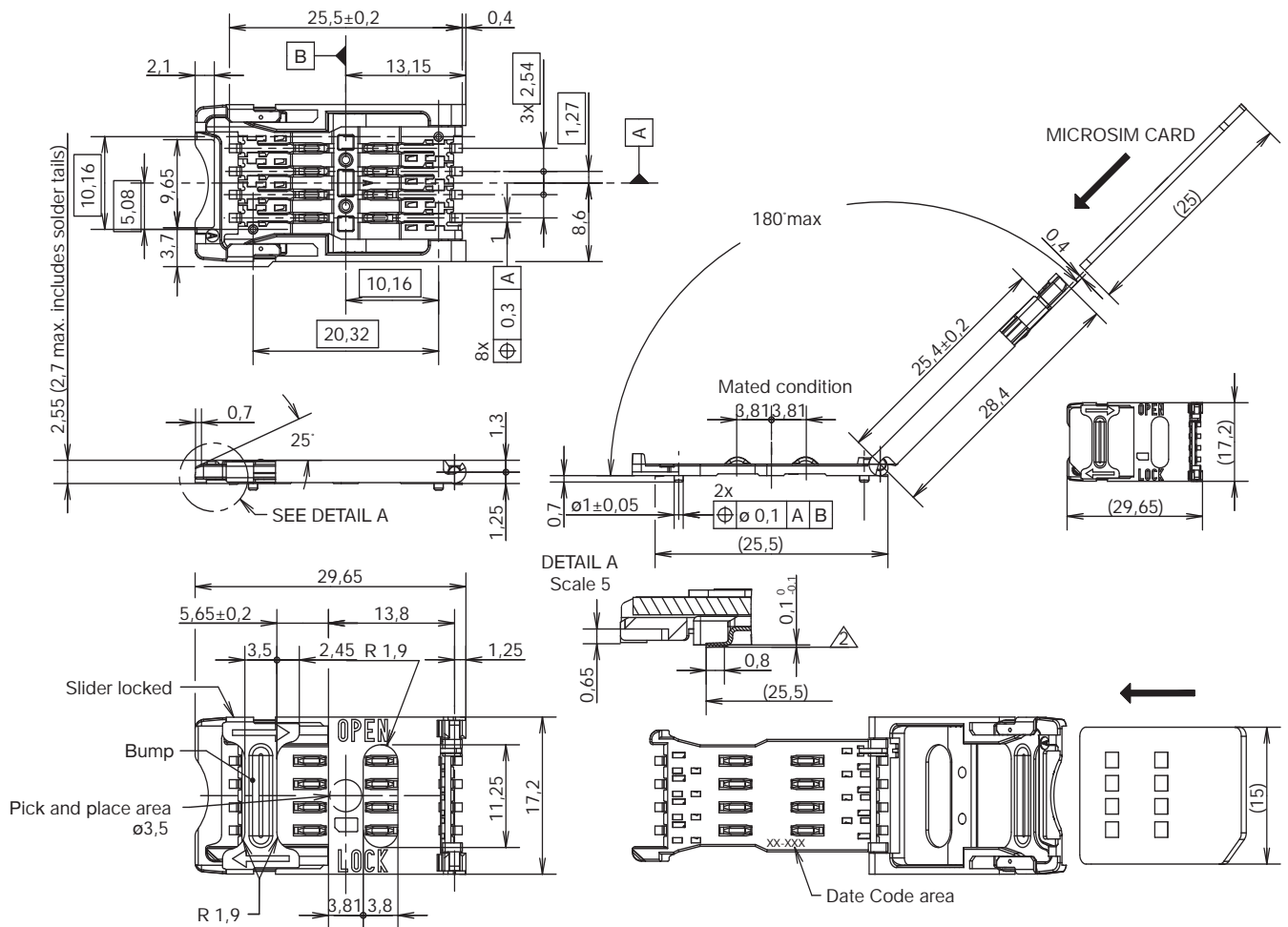

RECOMMENDED PC BOARD LAYOUT
(Component side)

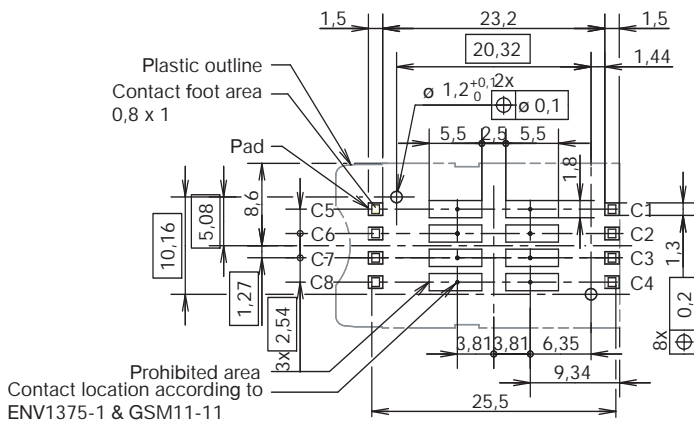

Dimensions are shown in mm
Specifications and dimensions subject to change

www.ck-components.com

SIM/SAM



CCM03 MK2 Series

CCM03-3011 LFT

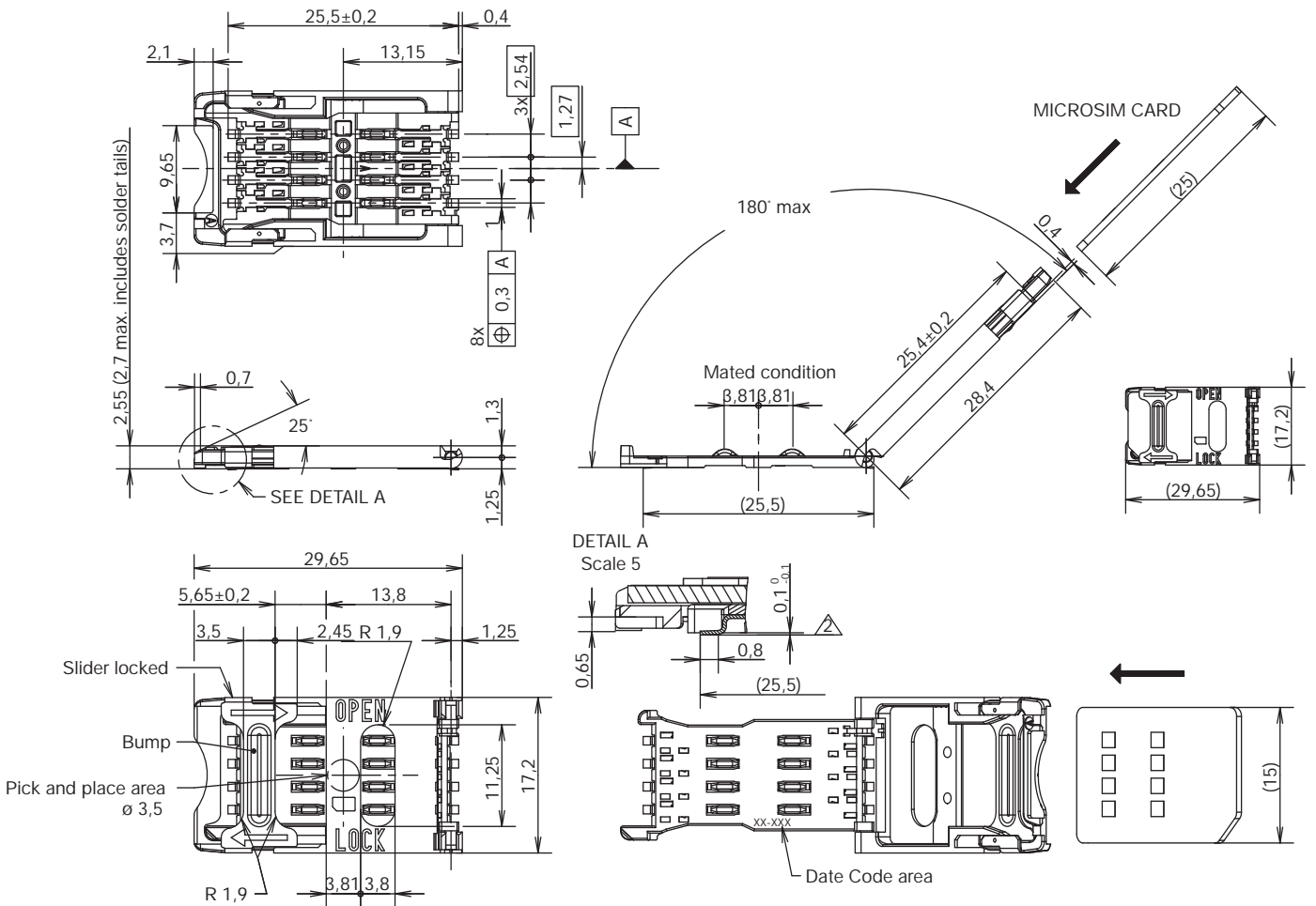

RECOMMENDED PC BOARD LAYOUT
(Component side)

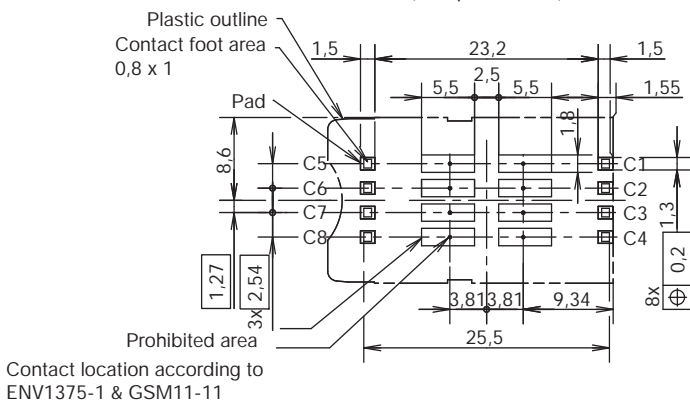

Dimensions are shown in mm
Specifications and dimensions subject to change

www.ck-components.com

CCM03 MK2 Series

CCM03-3512 LFT

SIM/SAM

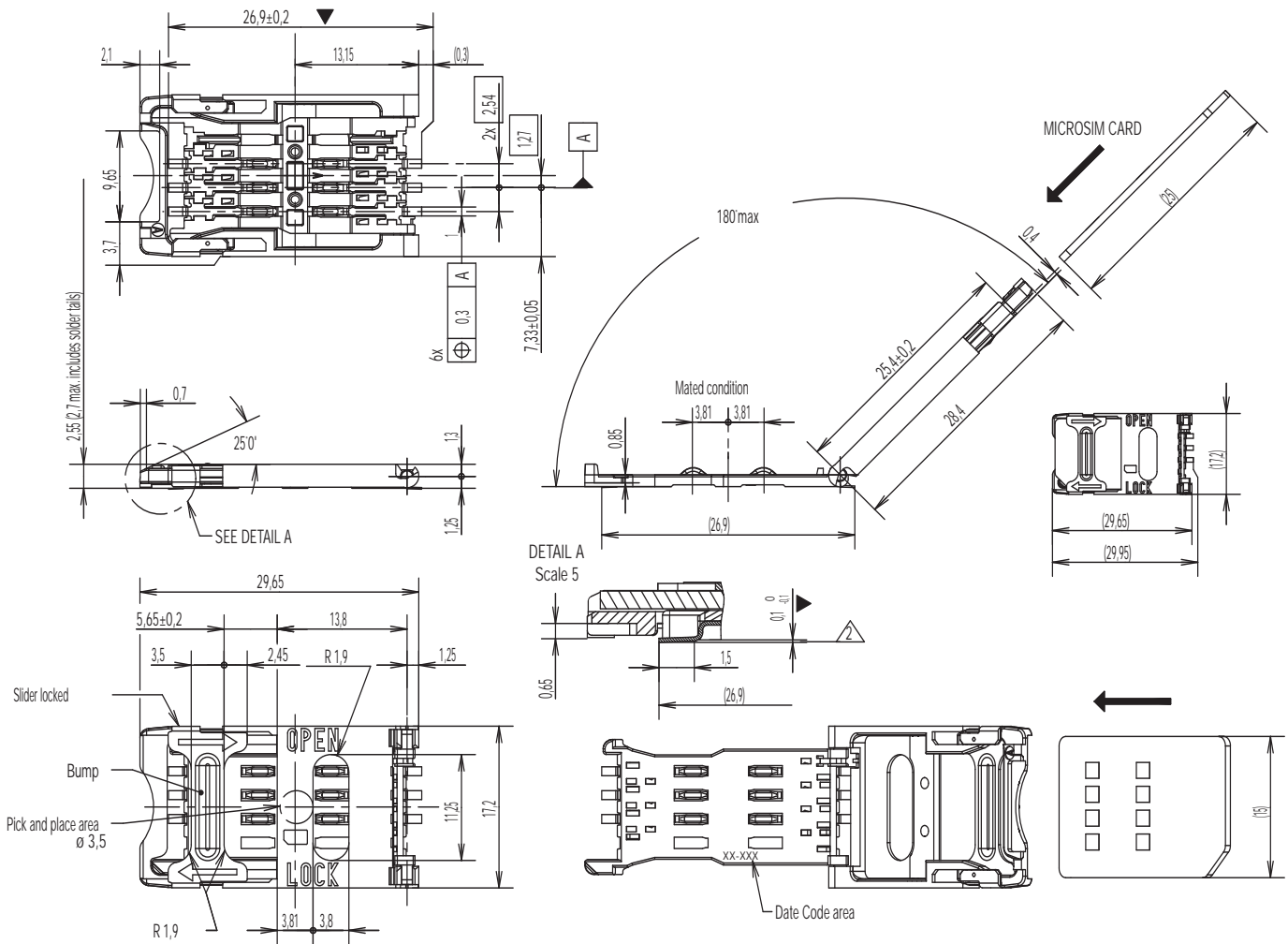

Dimensions are shown in mm
Specifications and dimensions subject to change

www.ck-components.com

CCM03 MK2 Series

CCM03-3504 LFT / CCM03-3505 LFT

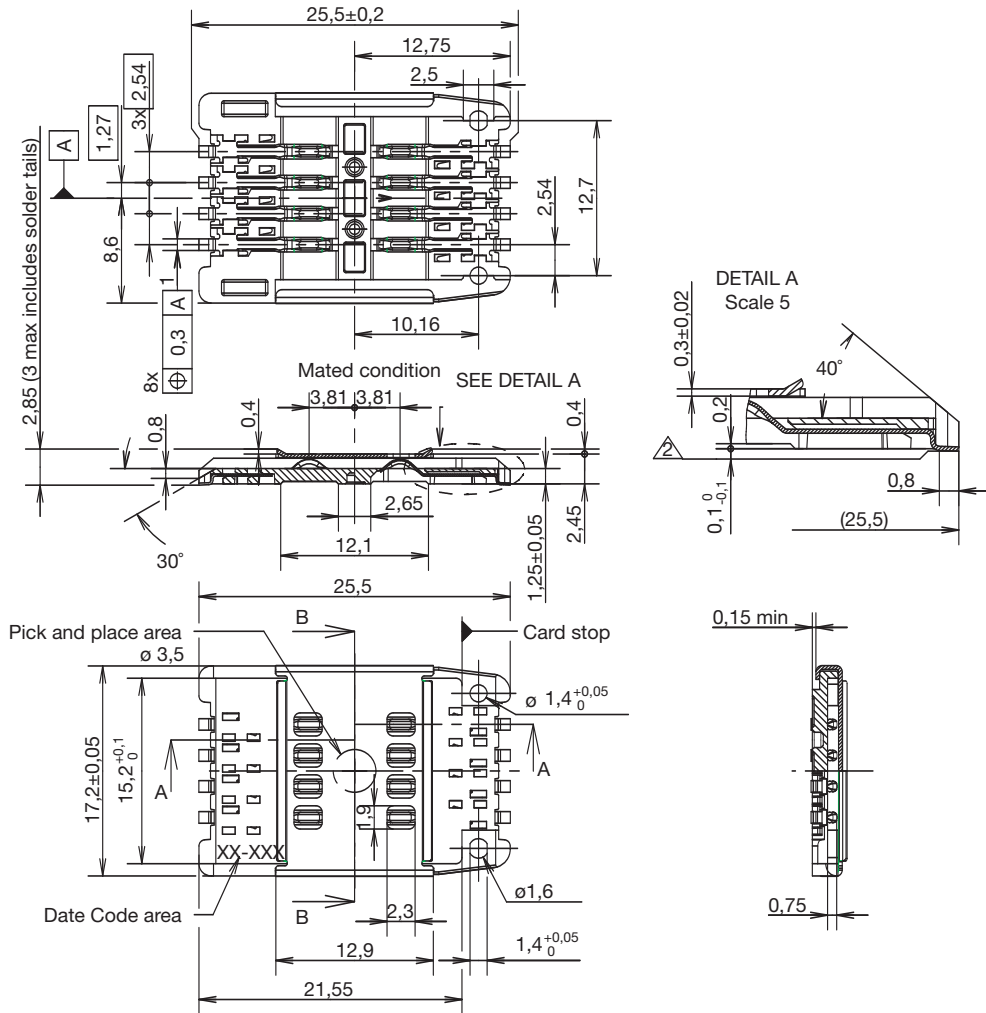

RECOMMENDED PC BOARD LAYOUT
(Component side)

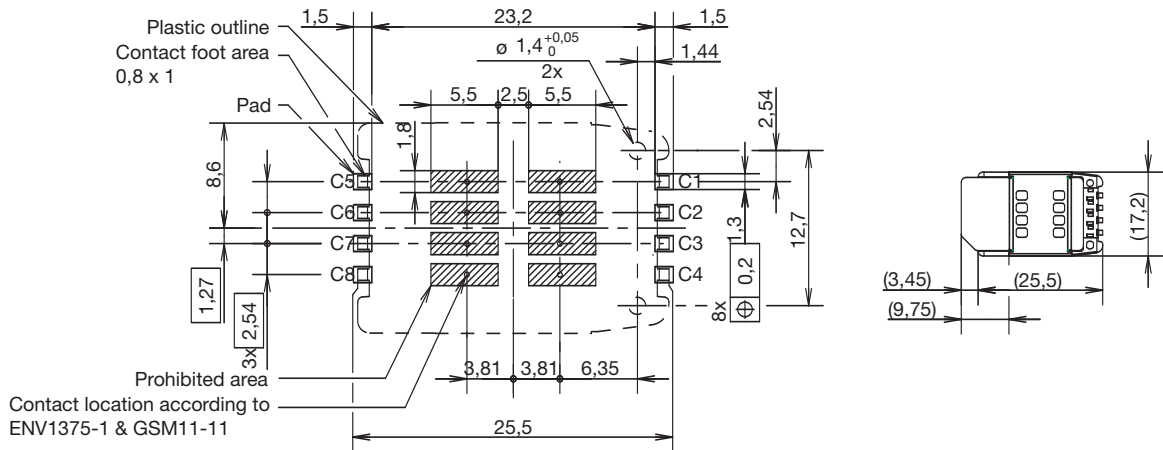

Dimensions are shown in mm
Specifications and dimensions subject to change

www.ck-components.com

CCM03 MK2 Series

CCM03-3754 LFT

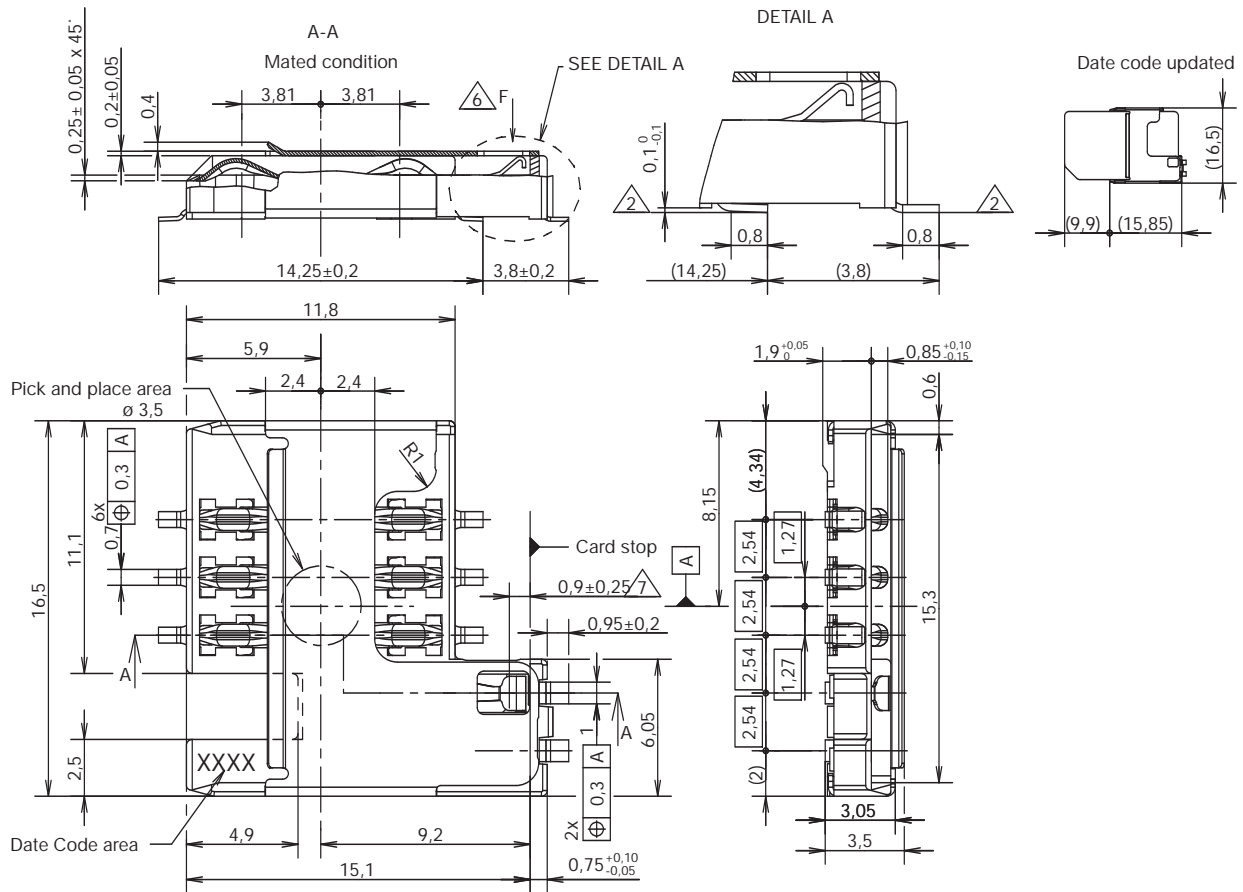

RECOMMENDED PC BOARD LAYOUT
(Component side)

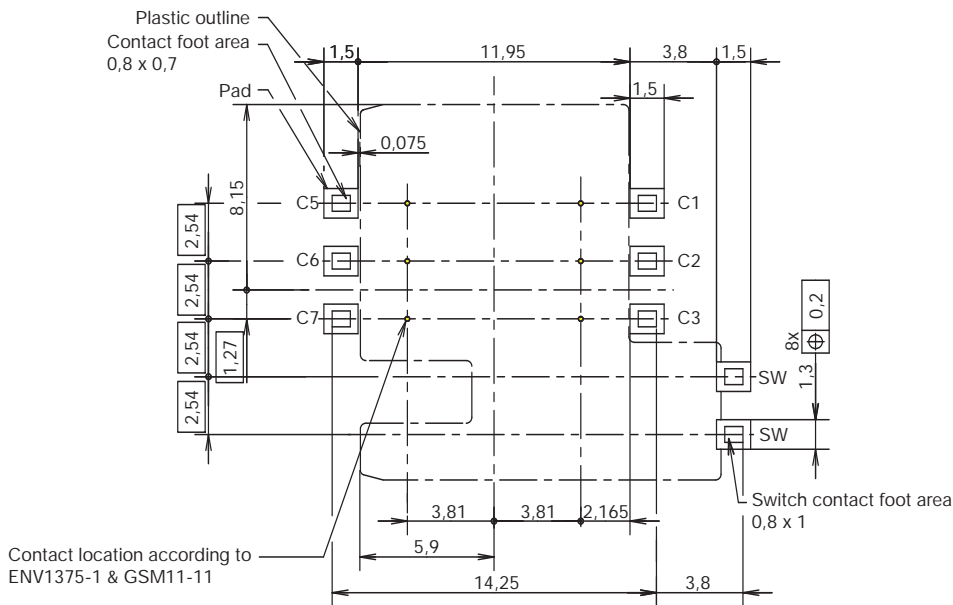

Dimensions are shown in mm
Specifications and dimensions subject to change

www.ck-components.com

SIM/SAM



CCM03 MK2 Series

CCM03-3760 LFT

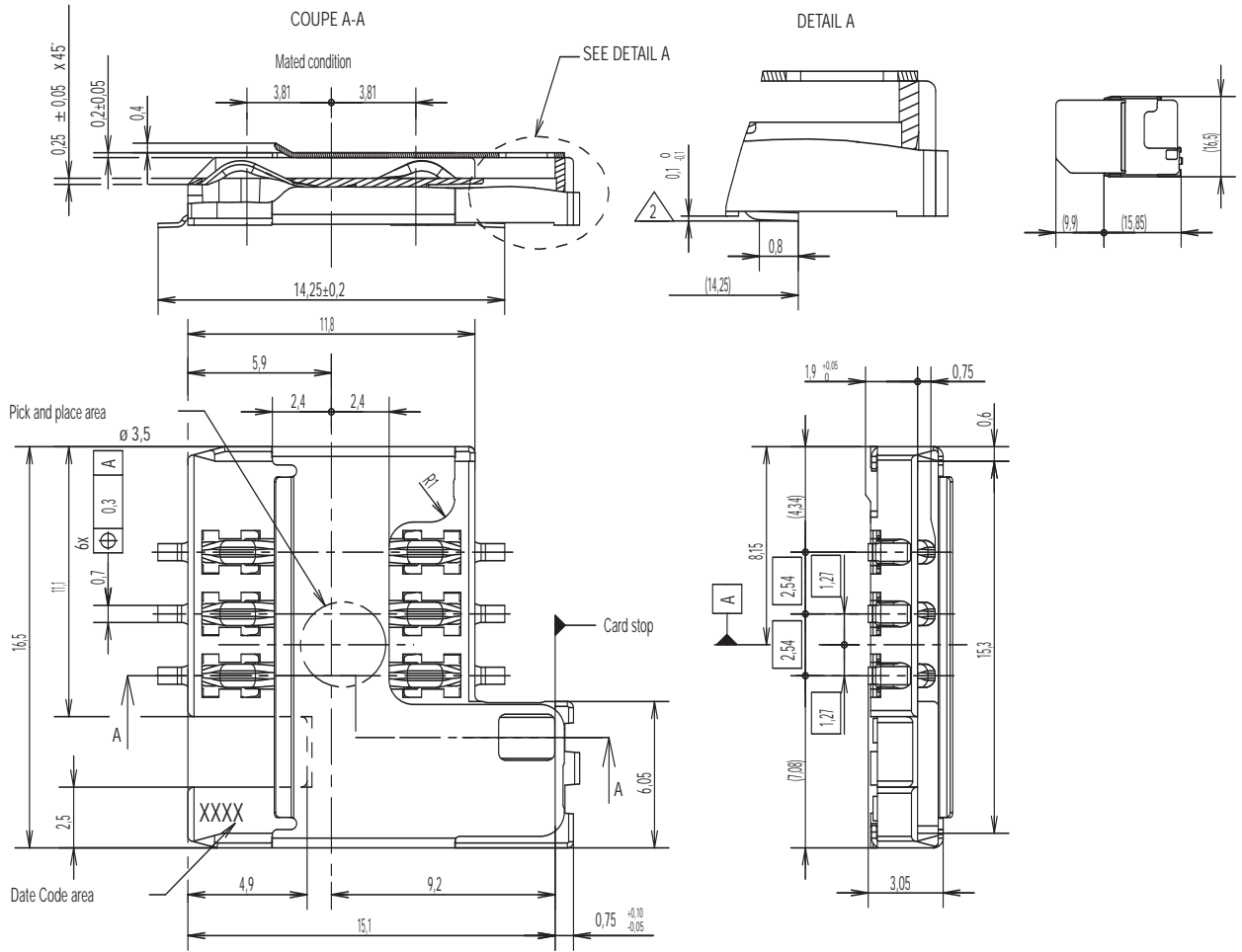

RECOMMENDED PC BOARD LAYOUT
 (Component side)

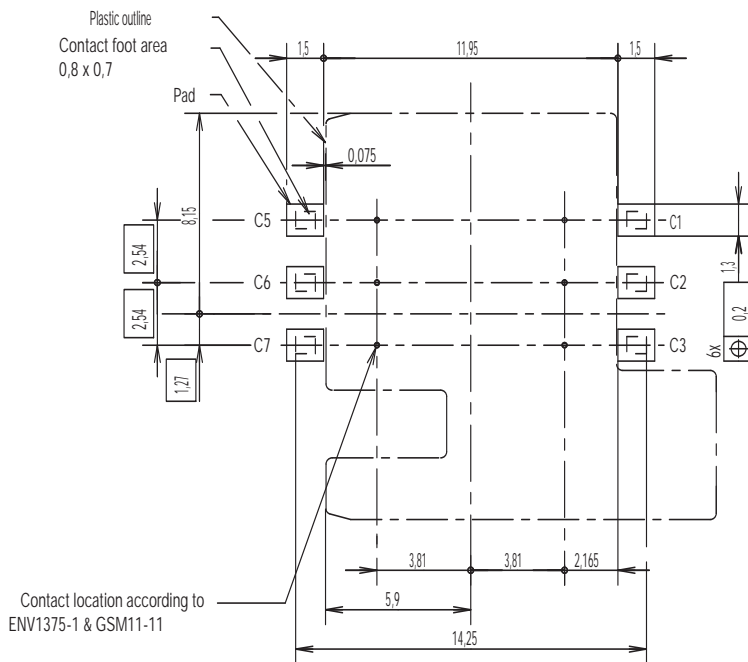

Dimensions are shown in mm
 Specifications and dimensions subject to change

www.ck-components.com

SIM/SAM

CCM03 MK2 Series

CCM03-3764 LFT

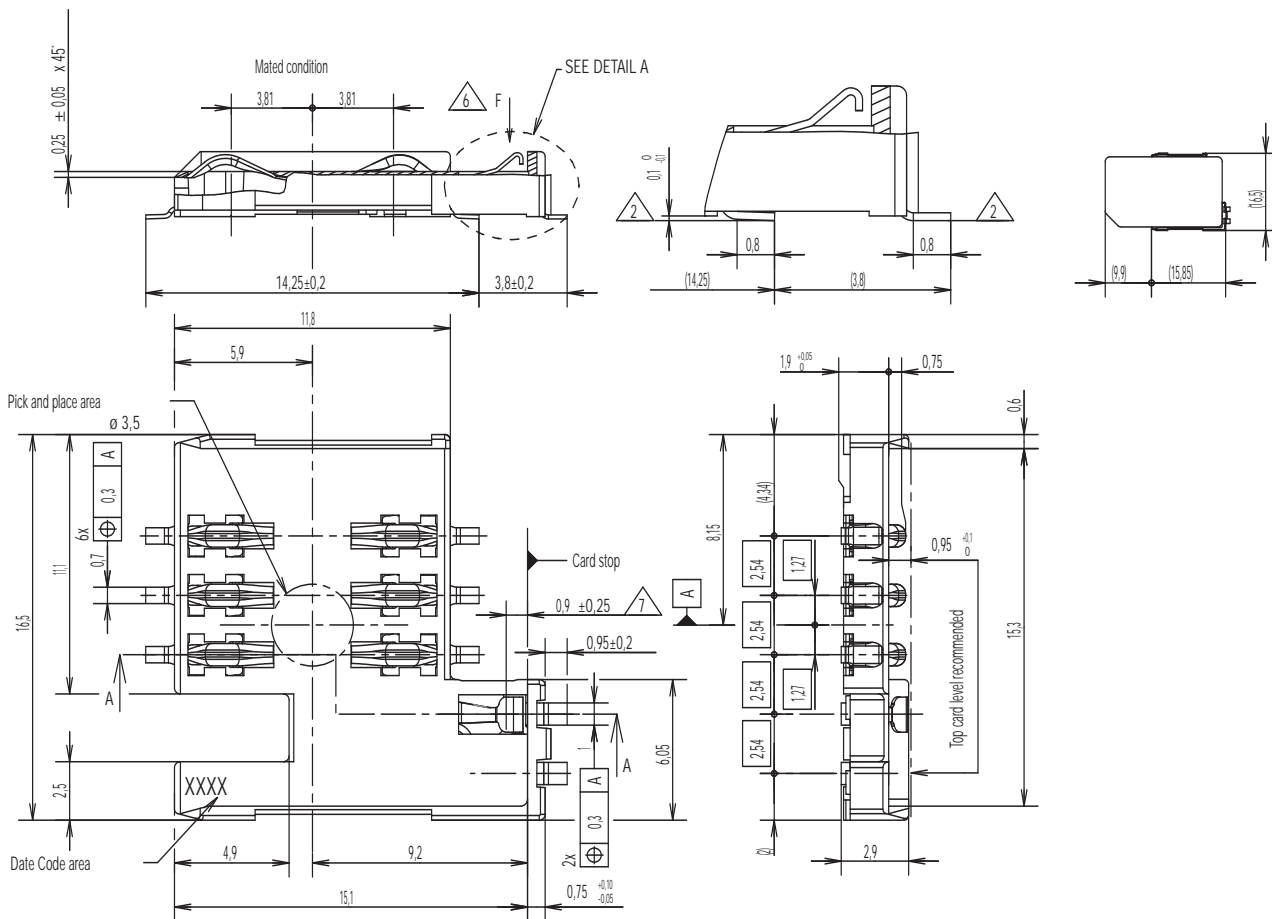

RECOMMENDED PC BOARD LAYOUT
(Component side)

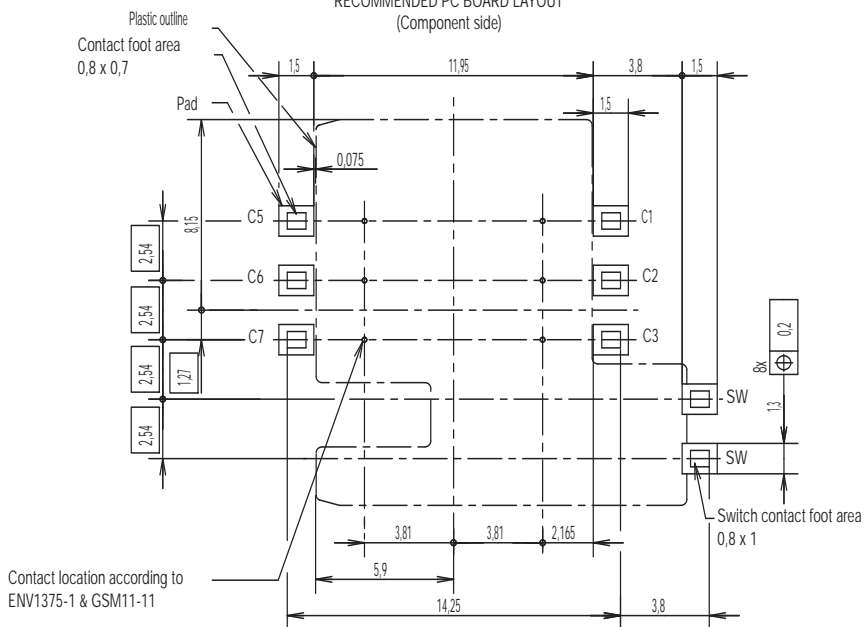

First Angle
Projection

Dimensions are shown in mm

Specifications and dimensions subject to change

www.ck-components.com

SIM/SAM



CCM04 MK3 Series



Features

- SIM and SAM card acceptance
- Compatible with pick and place and lead free soldering

Typical Applications

- Mobile
- POS
- Identification
- GPS

Mechanical

Number of contacts	6 or 8
Mechanical life	30,000 cycles
Card insertion force	10N max
Card extraction force	1N min / 10N max
Contact force	0,35N min to 0,65N
Vibration Frequency	10 to 500 Hz. Acceleration 50m/s ² Duration 6 hours - amplitude 0,35mm
Shock	Peak value 500 m/s ² – Duration 11 ms 3 shocks in each direction of each axis
Max elect. discontinuity	1µs

Packaging

See table below

Soldering Process

Compatible with lead free SMT soldering process

Contact Electrical Data

Insulation resistance	1000 MΩ min
Contact resistance max	100 mΩ max
Switching current	10 µA min / 1 A max
Dielectric strength	750 Vrms min

Environmental Data

Operating temperature	-40°C to +85°C
Salt mist	IEC 512 test number 11f (96 hours)
Damp heat	IEC 512 test number 11c (10 days)
RoHS compliant	

Designation	# of Contacts	Contact Plating	PCB Version	Height (mm)	Dim. (mm)	Packaging
CCM04-5137LFS	6	gold	SMT IN	1,9	8,15 X 10,45	reels of 1,900 pcs

CCM04 MK3 Series

CCM04-5137 LFS

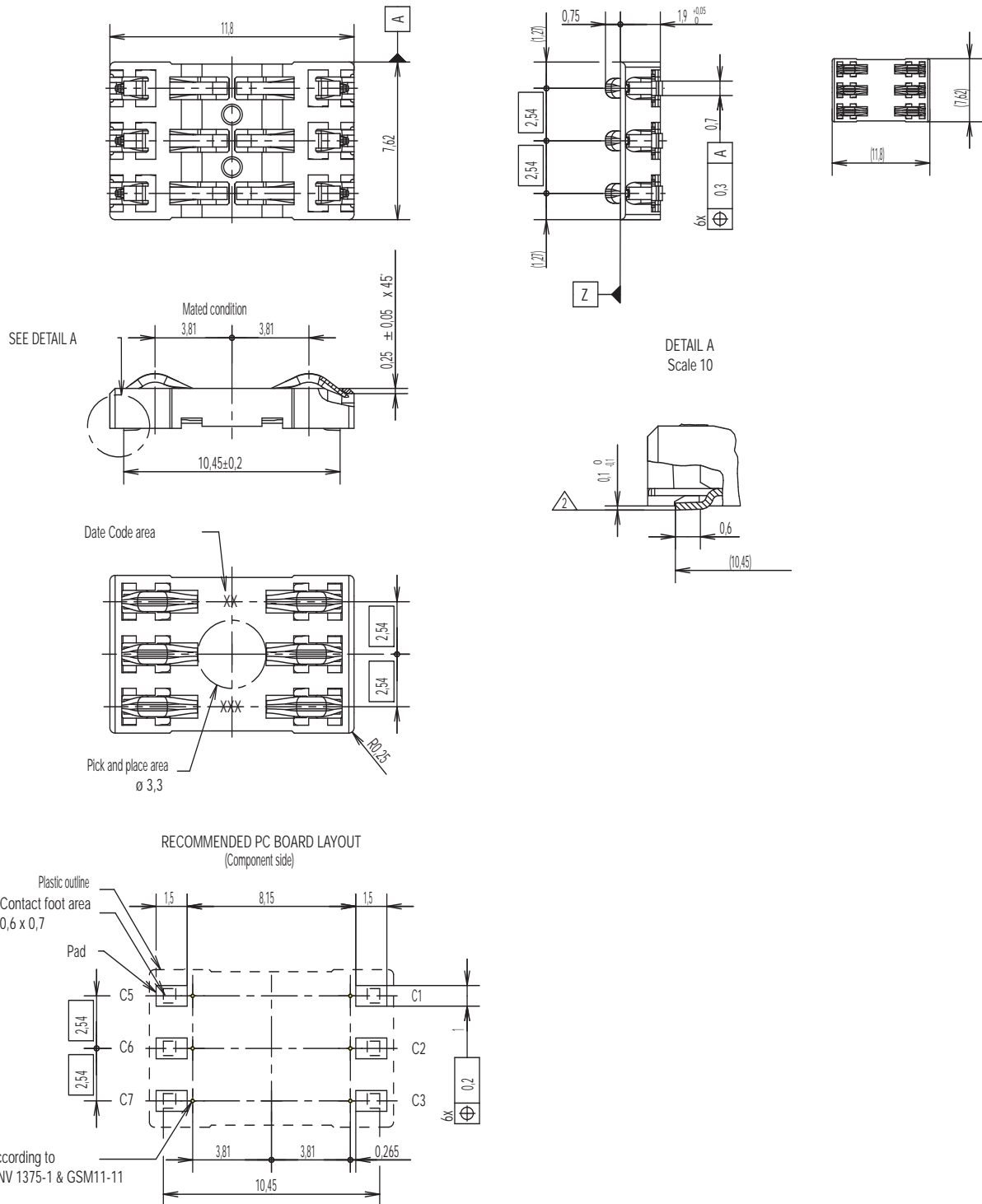

SIM/SAM



Dimensions are shown in mm
Specifications and dimensions subject to change

www.ck-components.com

X-ON Electronics

Largest Supplier of Electrical and Electronic Components

Click to view similar products for [Memory Card Connectors](#) category:

Click to view products by [C&K](#) manufacturer:

Other Similar products are found below :

[M21-033321-005](#) [6407-249V-25273P](#) [6407-249V-25343P](#) [6426-201-21343](#) [69.920.0553.0](#) [FCN-568P068-G/07-4V](#) [809180410000000](#)
[HMCAP001](#) [252-0144-000](#) [2041353-2](#) [33CFAE-DN](#) [502431-1011](#) [NX1-32T-KT3K\(05\)](#) [95622-003LF](#) [N7E50-U516RB-50-SIN0005](#) [95079-00CALF](#) [33DVIR-29S12R](#) [125A-78C00](#) [MI20A-50PD-SF-EJL\(71\)](#) [KP10S-SF-PEJ\(812\)](#) [504536-0691](#) [504580-0691](#) [CCM03-3109 B LFT](#)
[MI21-50PD-SF\(91\)](#) [2309923-1](#) [61126-050CAHLF](#) [IC1GA-68PD-1.27DS-EJ\(72\)](#) [GTFP08432B1HR](#) [G85DT17001P1EU](#)
[G85B21611142HHR](#) [GSD090144HR](#) [G85D1140022P1HR](#) [GMCB05801124EU](#) [G85C11101152HHR](#) [G85B231021B1HR](#)
[G85D1160022HHR](#) [112K-TAA0-RA1](#) [115S-ACA2](#) [115S-ACA3](#) [115S-BS00](#) [115S-BT00](#) [115V-AD00](#) [503960-0695](#) [101B-TAA0-R](#) [101D-TAAA-R01](#) [101D-TAAB-R01](#) [104D-TCA0-R06](#) [104B-TAA0-R](#) [112C-TBAR-R02](#) [114B-40B00-R02](#)