

# CCM03 MK2 Series

## Features

- SIM/SAM card acceptance
- Hinged and fixed covers
- Compatible with pick and place and lead free soldering

## Typical Applications

- Handheld products
- Identification
- POS
- Automotive

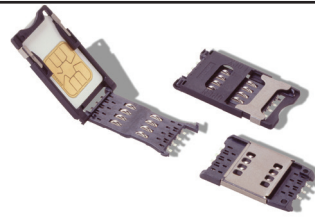

## Mechanical

Number of Contacts	6 or 8
Mechanical life, hinged cover	10,000 cycles min
Mechanical life, fixed cover	50,000 cycles
Card insertion force	Hinged cover: 1N max Fixed cover: 3N max
Card extraction force	Hinged cover: 1N max Fixed cover: 0,80N min / 3N max
Contact force	0,25N min / 0,50N max
Slide locking force	2N min / 6N max 1,8N max. for complete depression
Vibration Frequency	10 to 500 Hz. Acceleration 50m/s <sup>2</sup> Duration 6 hours - amplitude 0,35 mm
Max electrical discontinuity	1µs
Shock	Peak value 500 m/s <sup>2</sup> – Duration 11 ms 3 shocks in each direction of each axis

## Contact Electrical Data

Insulation resistance	1,000 MΩ min
Resistance	100 mΩ max
Current rating	10 µA min / 1 A max
Dielectric strength	750 Vrms min

## Switch Electrical Data

Card detection switch	Normally open
Contact resistance	100 mΩ max
Dielectric strength	250 Vrms min
Current rating	1 mA min / 10m A max
Maximum power	0.2 VA

## Environment Data

Operating temperature	-40°C to +85°C
Damp heat	IEC 512 test number 11c (10 days)
Salt mist	IEC 512 test number 11f (96 hours)
RoHS compliant	

## Soldering Process

Compatible with lead free SMT soldering process



Designation	Contact Plating	Cover	# of Contacts	PCB Version	Card Presence Switch	Operating Life	Total Height (mm)	Dim. (mm)	Packaging
CCM03-3001LFT	inlay	hinged	6		without	10,000	2,55	17,2 x 29,65	reels of 1,000 pcs
CCM03-3002LFT	inlay	hinged	6	2 plastic pegs	without	10,000	2,55	17,2 x 29,65	reels of 1,000 pcs
CCM03-3003LFT	inlay	hinged	8		without	10,000	2,55	17,2 x 29,65	reels of 1,000 pcs
CCM03-3004LFT	inlay	hinged	8	2 plastic pegs	without	10,000	2,55	17,2 x 29,65	reels of 1,000 pcs
CCM03-3009LFT	gold	hinged	6		without	10,000	2,55	17,2 x 29,65	reels of 1,000 pcs
CCM03-3010LFT	gold	hinged	6	2 plastic pegs	without	10,000	2,55	17,2 x 29,65	reels of 1,000 pcs
CCM03-3011LFT	gold	hinged	8		without	10,000	2,55	17,2 x 29,65	reels of 1,000 pcs
CCM03-3012LFT	gold	hinged	8	2 plastic pegs	without	10,000	2,55	17,2 x 29,65	reels of 1,000 pcs
CCM03-3013LFT	gold	hinged	6		with	10,000	2,55	17,2 x 29,65	reels of 1,000 pcs
CCM03-3512LFT	gold	hinged	6	Large soldering pads*	without	10,000	2,55	17,2 x 29,65	reels of 1,000 pcs
CCM03-3504LFT	gold	fixed	8		without	50,000	2,85	17,2 x 25,5	reels of 1,000 pcs
CCM03-3505LFT	gold	fixed	6		without	50,000	2,85	17,2 x 25,5	reels of 1,000 pcs

\* Can go through reflow upside down

# CCM03 MK2 Series

## CCM03-3001 LFT / CCM03-3009 LFT

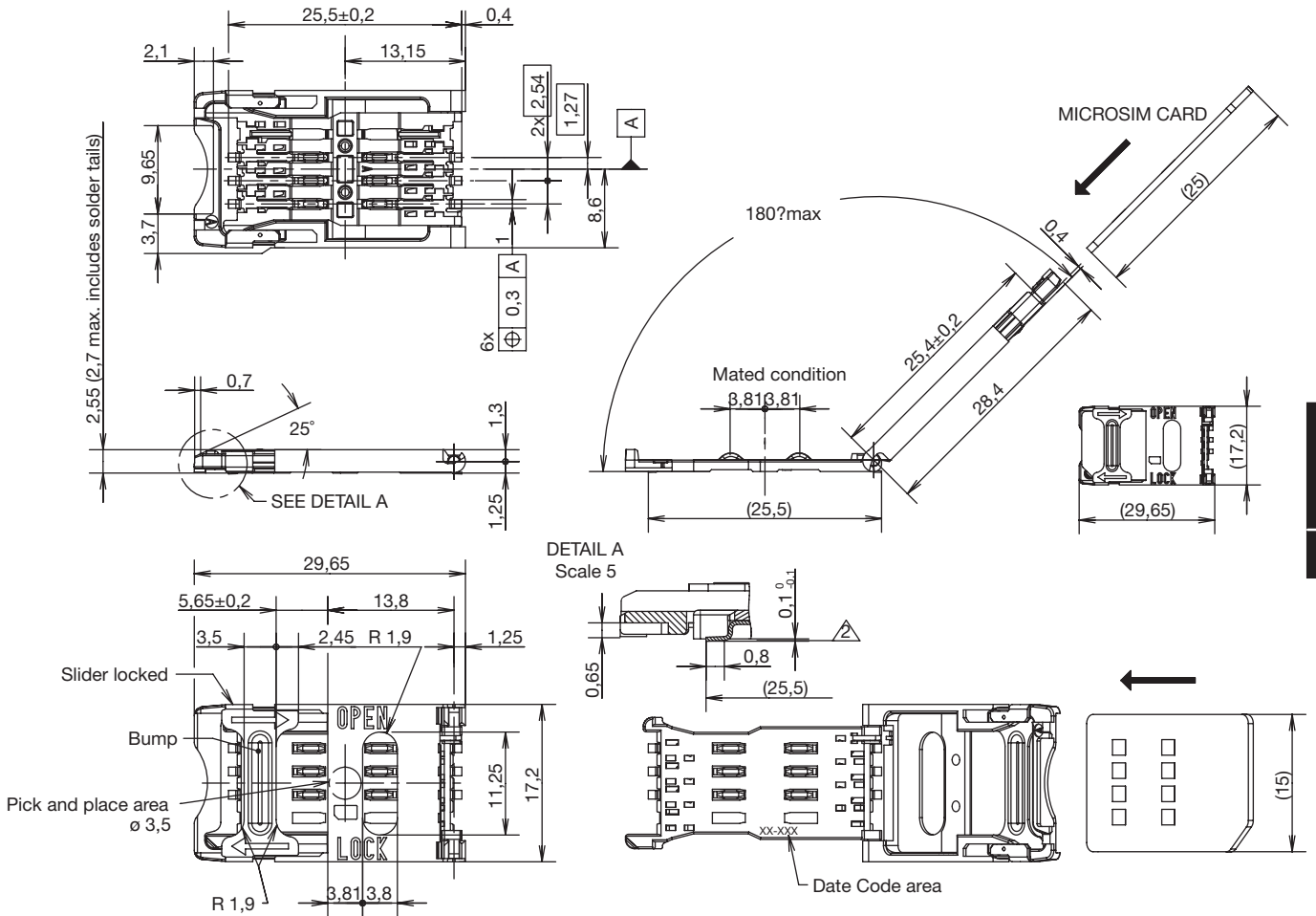

**SIM/SAM**

### RECOMMENDED PC BOARD LAYOUT (Component side)

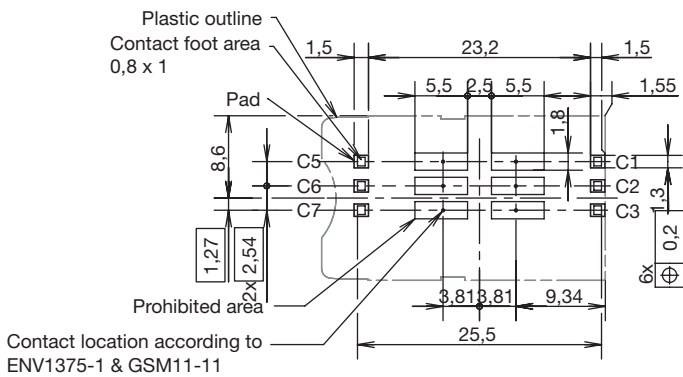



# CCM03 MK2 Series

## CCM03-3003 LFT

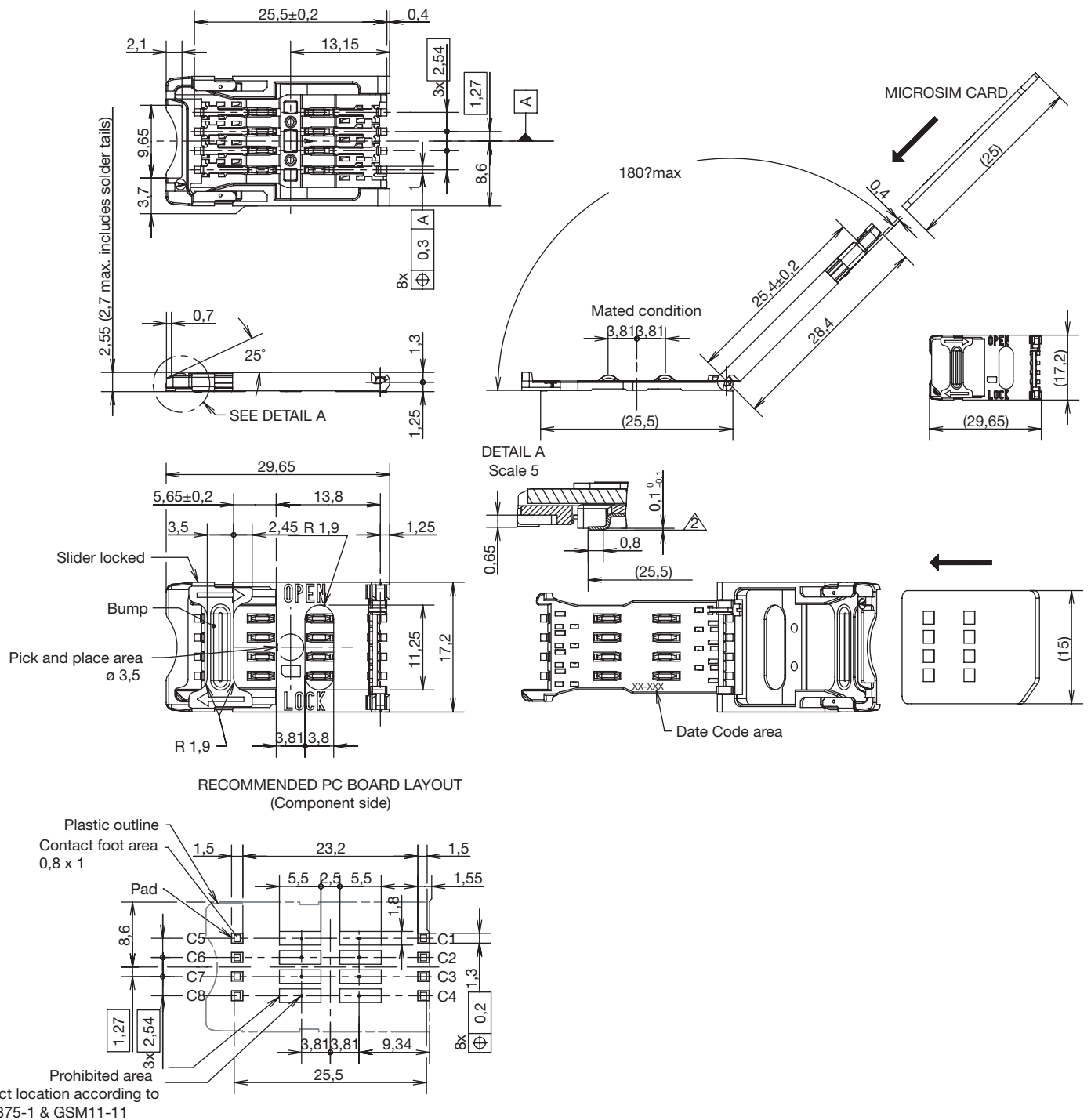

SIM/SAM

# CCM03 MK2 Series

CCM03-3004 LFT

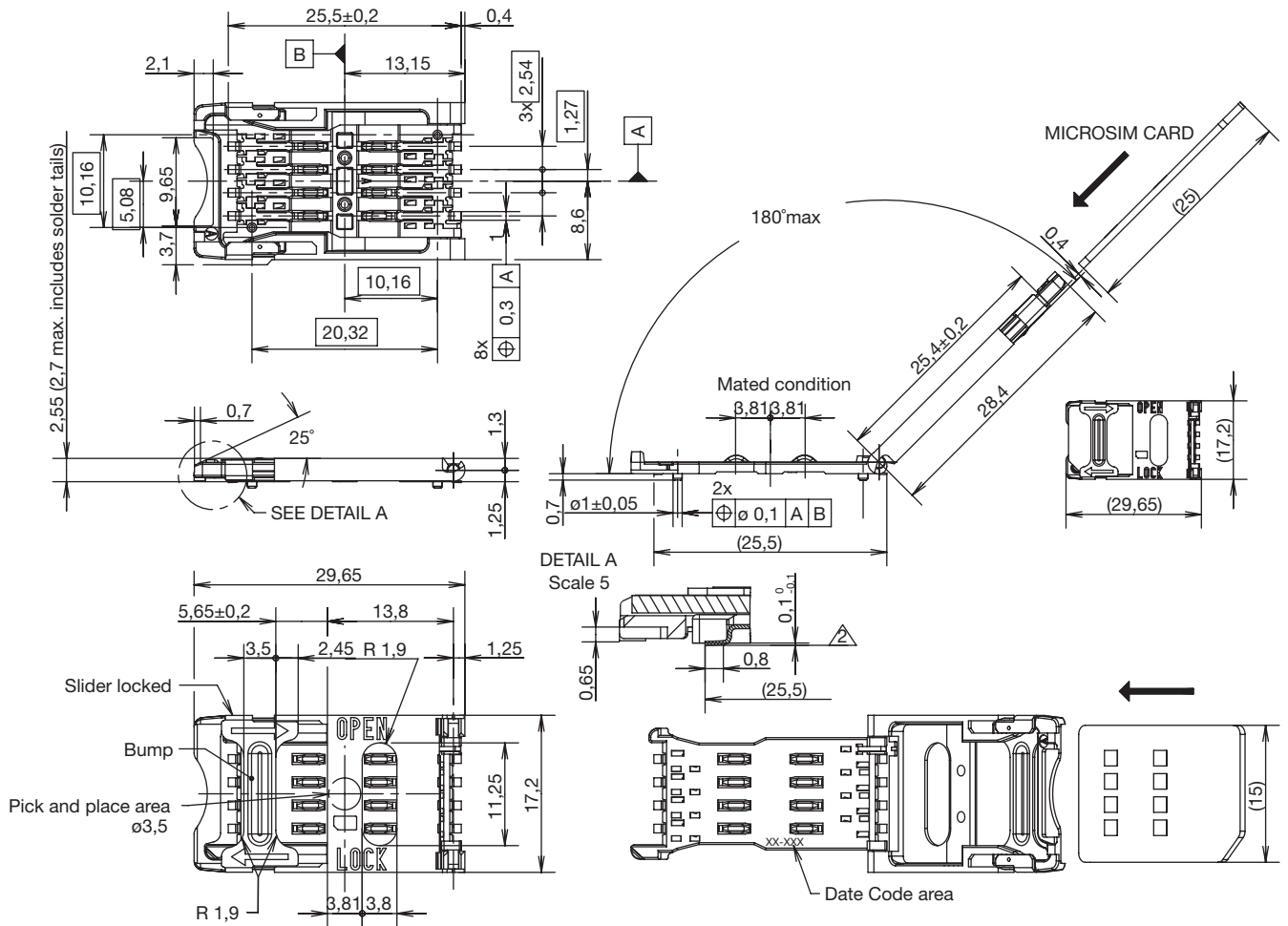

RECOMMENDED PC BOARD LAYOUT  
(Component side)

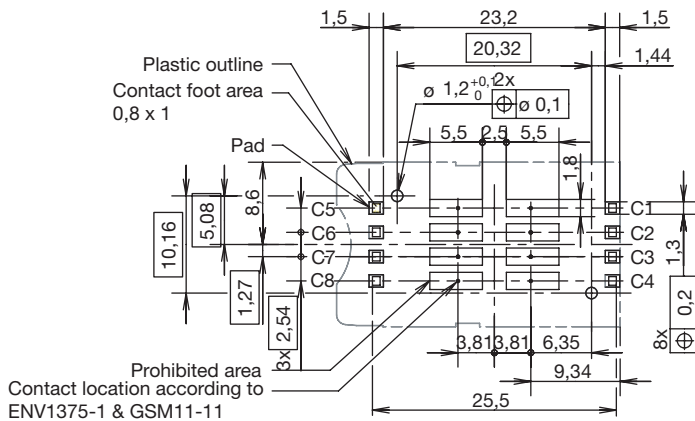

Dimensions are shown in mm  
Specifications and dimensions subject to change

www.ckswitches.com

SIM/SAM



10 Mar 21

# CCM03 MK2 Series

## CCM03-3011 LFT

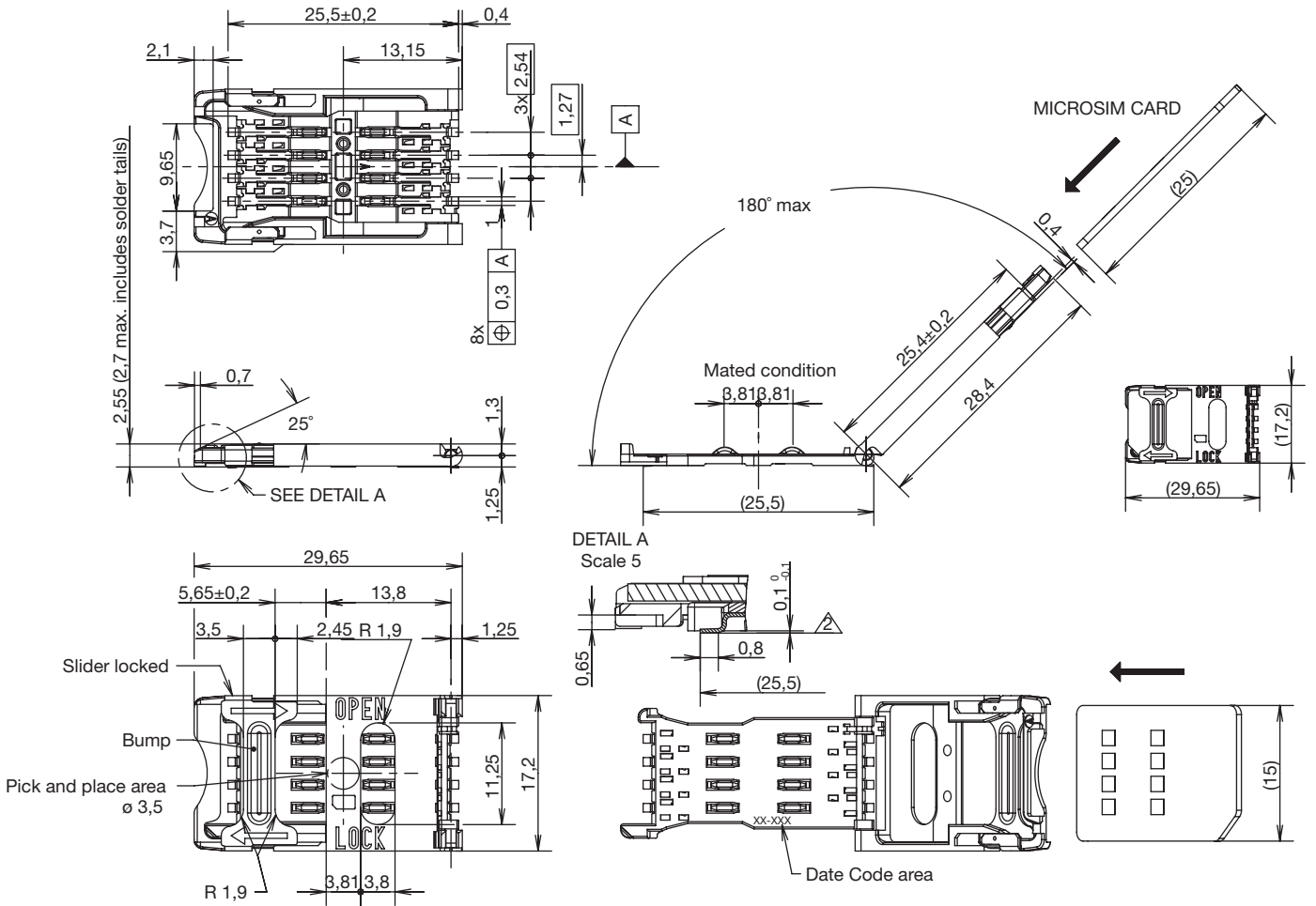

### RECOMMENDED PC BOARD LAYOUT (Component side)

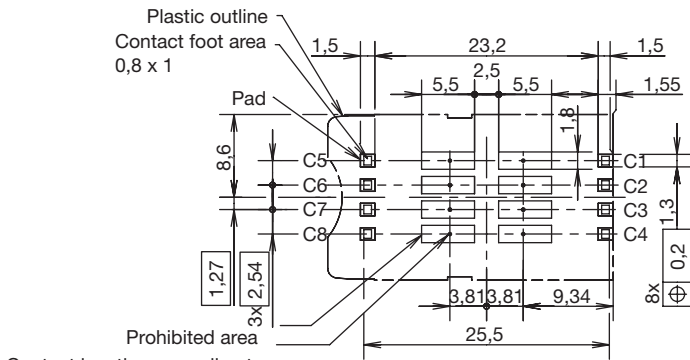

10 Mar 21



First Angle  
Projection

Dimensions are shown in mm  
Specifications and dimensions subject to change

www.ckwitches.com







# CCM03 MK2 Series

CCM03-3512 LFT

SIM/SAM

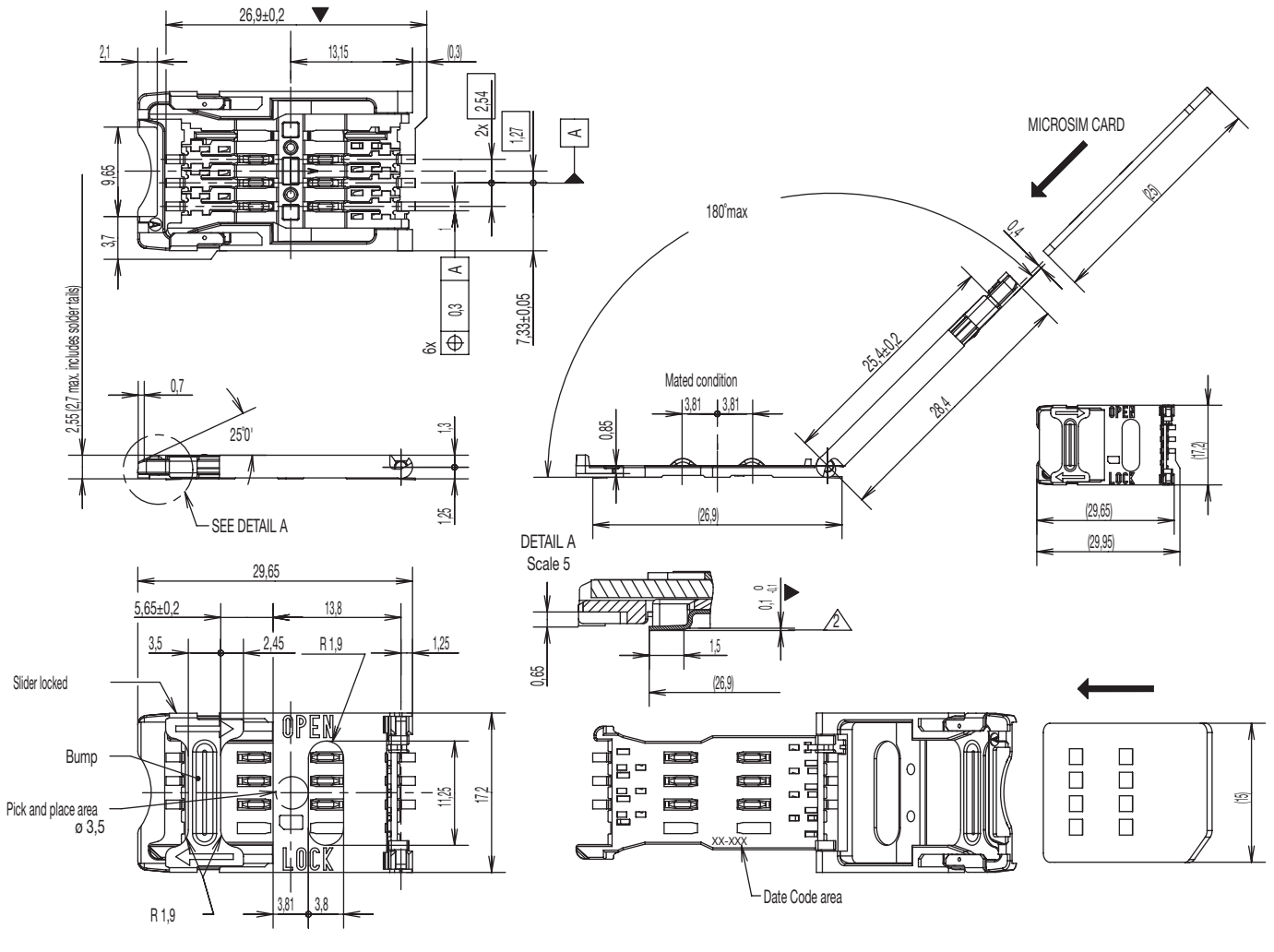

Dimensions are shown in mm  
Specifications and dimensions subject to change

www.ckswitches.com



10 Mar 21



## X-ON Electronics

Largest Supplier of Electrical and Electronic Components

*Click to view similar products for [Memory Card Connectors](#) category:*

*Click to view products by [C&K](#) manufacturer:*

Other Similar products are found below :

[M21-033321-005](#) [6407-249V-25273P](#) [6407-249V-25343P](#) [6426-201-21343](#) [69.920.0553.0](#) [FCN-568P068-G/07-4V](#) [809180410000000](#)  
[N7E50-7516PG-20-WF](#) [HMCAP001](#) [252-0144-000](#) [2041353-2](#) [33CFAE-DN](#) [502431-1011](#) [617230001](#) [NX1-32T-KT3K\(05\)](#) [95622-003LF](#)  
[N7E50-U516RB-50-SIN0005](#) [95079-00CALF](#) [84648-056HLF](#) [33DVIR-29S12R](#) [125A-78C00](#) [MI20A-50PD-SF-EJL\(71\)](#) [KP10S-SF-](#)  
[PEJ\(812\)](#) [504536-0691](#) [504580-0691](#) [CCM03-3109 B LFT](#) [MI21-50PD-SF\(91\)](#) [2309923-1](#) [61126-050CAHLF](#) [IC1GA-68PD-1.27DS-EJ\(72\)](#)  
[GTFP08432B1HR](#) [G85DT17001P1EU](#) [G85B21611142HHR](#) [GSD090144HR](#) [G85D1140022P1HR](#) [GMCB05801124EU](#) [G85C11101152HHR](#)  
[G85B231021B1HR](#) [G85D1160022HHR](#) [XKSIM-114](#) [123A-21M00](#) [123A-30B00](#) [123A-30A00](#) [123A-21A00](#) [123A-21B00](#) [123A-21E00](#)  
[123A-30E00](#) [123A-30M00](#) [123A-40A00](#) [123A-40E00](#)