



C&K Switches Catalog

Pushbutton

Tactile

Navigation

Keyswitch

Detect

Toggle

Rocker

Dip

Slides

Snap

Rotary

Rotary (Encoder)

Switchlock

Thumbwheel

Smartcard Connector

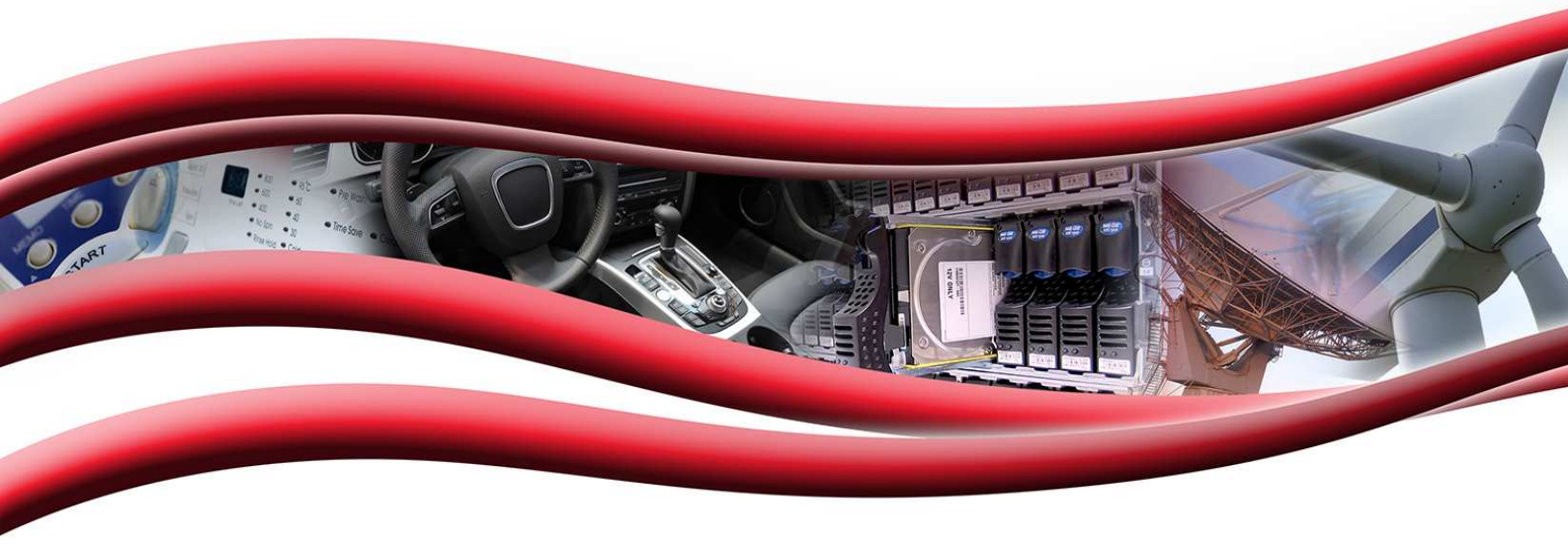



Pushbutton Product Selection Guide

| | | | | | | | | | |
|--------------------------|---------------|------------------|------------------|------------------|------------------------|-------------|------------------|---------------|---------------|
| Pushbutton | | | | | | | | | |
| Series | ELUM | EP | TP | E020 | 8020 | E010 | 8060 | 8500 | KM |
| Switch Type | Mom./Latching | Tiny | Tiny | Snap-acting Mom. | Snap-acting Mom. | Miniature | Alternate Action | Sub-miniature | Sub-miniature |
| Poles/Throws | SPDT | SPST, SPDT, DPST | SPST, SPDT, DPST | SPDT, DPDT | SPDT, DPDT, 3PDT, 4PDT | SPDT | SPDT, DPDT | SPST | SPST, SPDT |
| Max. Current | 3.5 VA | 1 Amp | 1 Amp | 1 Amp | 1 Amp | 4 Amps | 6 Amps | 3 Amps | 1 Amp |
| Process Sealed | | • | | • | | • | | | |
| Illuminated | • | | | | • | | • | • | |
| PCB Mount Options | | | | | | | | | |
| Thru-hole | • | • | • | • | • | • | • | • | • |
| Vertical | | • | • | • | • | • | • | • | • |
| Right Angle | • | • | • | • | • | • | • | • | • |
| Surface Mount | • | • | | | | | | | |
| Panel Mount | | | • | | • | • | • | • | • |
| Page No. | A-4 | A-9 | A-15 | A-21 | A-29 | A-46 | A-52 | A-62 | A-67 |

| | | | | | | | |
|--------------------------|-----------------|-------------|-----------------|-------------------------|--------------|-------------------------------|-------------------|
| Pushbutton | | | | | | | |
| Series | 8600 | 8700 | GP | PN | PHB | F | NE-18 |
| Switch Type | Micro-miniature | Over Travel | Ultra-miniature | Alternate & Mom. Action | Short Stroke | Alternate & Mom. Action | Mains / Power |
| Poles/Throws | SPST | SPST | SPST, SPDT | SPDT, DPDT, 4PDT | DPDT, 4PDT | DPDT, 4PDT, 6PDT, 8PDT, 10PDT | DPST, DPDT Varied |
| Max. Current | 500 mA | 1 Amp | 0.4 VA | 200 mA | 100 mA | 500 mA | 6 A |
| Process Sealed | | | • | | | | |
| PCB Mount Options | | | | | | | |
| Thru-hole | • | • | • | • | • | • | • |
| Vertical | • | • | • | | | | |
| Right Angle | | | • | • | • | • | • |
| Surface Mount | | | • | | | | |
| Panel Mount | • | • | | | | • | • |
| Page No. | A-71 | A-74 | A-77 | A-81 | A-84 | A-87 | A-96 |

Pushbutton Product Selection Guide

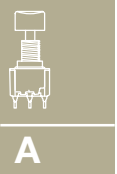

A
Pushbutton

| Pushbutton |  |  |  |  |  |  |  |  |
|-------------------|---|---|---|---|--|---|---|---|
| Series | FP | AP | APB | HP | NP | PBA | PB | PS |
| Switch Type | Ultra Miniature | Industrial | Industrial | Hall Effect | Sealed Power | Snap-acting Mom. | Miniature | Sub-miniature Microminiature |
| Poles/Throws | SPST | SPST | SPST | Linear Output | SPDT | DPST | DPDT 4PDT | SPDT DPDT |
| Max. Current | 0.4 VA | 400mA | 400mA | 10 mA | 5 Amp | 250mA | 0.3A / 1A | 0.1 / 1A 0.3 / 2A |
| Process Sealed | • | IP67 | IP67 | IP68 | IP68 | | | |
| PCB Mount Options | | | | | | | | |
| Thru-hole | • | • | • | | • | • | • | • |
| Vertical | • | • | • | • | • | | | • |
| Right Angle | • | | | | | • | • | • |
| Panel Mount | | • | • | • | • | | | • |
| Wire Leads | | • | • | • | • | | | |
| Solder Lug | | • | • | | | | | |
| Surface Mount | | | | | | | | |
| Quick Connect | | | | | | | | |
| Page No. | A-105 | A-108 | A-114 | A-118 | A-120 | A-127 | A-131 | A-139 |



Pushbutton
A

ELUM™ Series Right Angle Illuminated Latching Pushbutton

**LEAD FREE
COMPATIBLE OPTION**

Features/Benefits

- **SPDT (N.O. & N.C.)**
- **Low height above PCB**
- **Reliable self-cleaning contact**
- **Surface-mount or thru-hole PCB**
- **Standard or custom actuator**
- **Central LED illumination**
- **Latching or Momentary**
- **Long travel. Smooth feel**
- **RoHS compliant and compatible**

Typical Applications

- **Telecom network equipment**
- **Automotive electronics**
- **Consumer electronics**
- **Computer, server, modem, data storage**
- **Professional instrumentation, medical**

Patent Numbers
6,974,924 B2 US
EP1583118B1 Europe



Materials

FIXED CONTACTS: Stainless steel, silver plated with gold flash
 TERMINALS: Stainless steel, silver plated
 MOVABLE CONTACTS: Copper alloy, silver plated with gold flash
 BASE: Glass filled LCP (UL94V-0)
 ACTUATOR: Glass filled nylon 4/6 (UL94V-0)
 COVER: Stainless steel

Electrical

MAXIMUM POWER: 3.5 VA
 MIN./MAX. VOLTAGE: 20 mV – 50 VDC
 MIN./MAX. CURRENT: 0.01 mA – 250 mA
 DIELECTRIC STRENGTH: ≥ 250 Vrms
 CONTACT RESISTANCE: ≤ 50 mΩ
 INSULATION RESISTANCE: ≥ 10⁹ Ω
 BOUNCE TIME: ≤ 1 ms
 LED SPECIFICATIONS: See page A-5

Mechanical

OPERATING FORCE: 2.5 N at Full Travel
 SWITCHING TRAVEL: .067" (1.7 mm)
 LATCH TRAVEL: .131" (3.6 mm)
 FULL TRAVEL: .200" (5.1 mm)

Operating Environment

OPERATING TEMPERATURE: -40°C TO 80°C.
 STORAGE TEMPERATURE: -40°C TO 80°C.
 RELATIVE HUMIDITY: 90% R.H. @ 80°C.
 OPERATING LIFE: 30,000 Cycles.
 VIBRATION: Per EIA 186-E Method
 MECHANICAL SHOCK: Per EIA 186-E Method 12.
 OVERLOAD: Withstands 40 N for 1 minute without damage

Process Environment

SOLDERABILITY: According to Mil STD 202F Method 208D or EIA RS-186E Method 9.
 LEAD FREE PROCESS COMPATIBLE: 260°C peak, 10 seconds Max. above 250° C.
 WASHING PROCESS: No clean process compatible (SMT)
 Bottom wash compatible (Thru-hole)
 SHEAR TEST (SWITCH/PCB): > 40 N

Packaging

"SA" Terminal Style SMT: Tape and reel per EIA 481-2 (450/reel)
 "TH" Terminal Style PC: Tray (60/tray)

NOTE: Any models supplied with Q, contact material are RoHS compliant.

NOTE: Specifications and materials listed above are for switches with standard options. For information on specific and custom switches, please contact Customer Service.

Build-A-Switch

To order, simply select desired option from each category and place in the appropriate box.

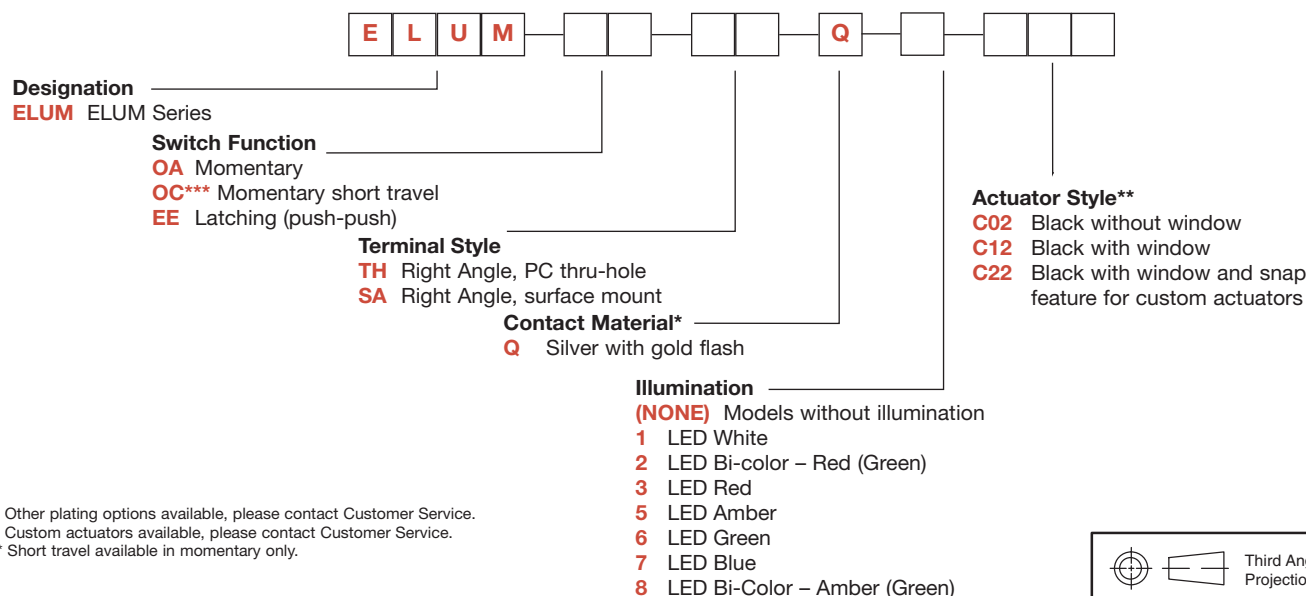

* Other plating options available, please contact Customer Service.
 ** Custom actuators available, please contact Customer Service.
 *** Short travel available in momentary only.

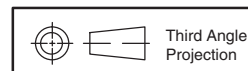

Dimensions are shown: Inches (mm)
Specifications and dimensions subject to change

ELUM™ Series Right Angle Illuminated Latching Pushbutton



STANDARD OPTIONS

ELUMEESAQ7C12

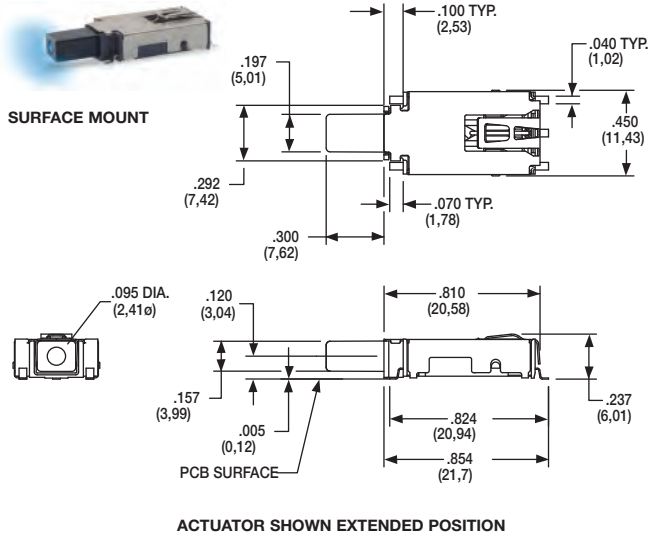

ELUMOATHQ6C12

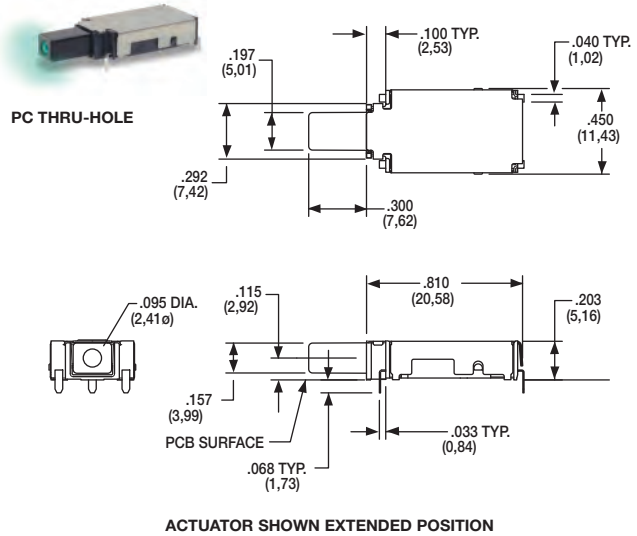

ELUMEESAQ3C22

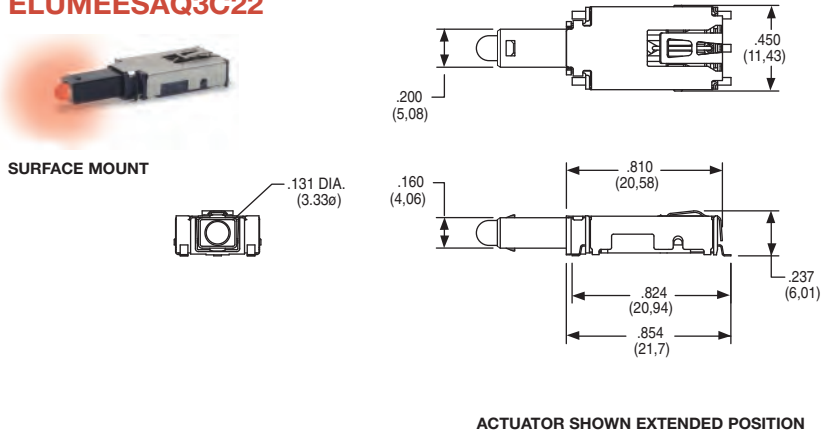

DESIGNATION **E L U M** □ □ □ □ □ □ □ □ □ □

ELUM ELUM SERIES, Illuminated Latching Pushbutton

SWITCH FUNCTION

| OPTION CODE | NO. OF POLES | POSITION 1 | CONNECTED TERMINALS | POSITION 2 | CONNECTED TERMINALS | SCHEMATIC |
|----------------|-------------------------|-----------------|---------------------|-----------------|---------------------|-----------------------------------|
| | | SWITCH FUNCTION | | SWITCH FUNCTION | | |
| OA / OC | SP Momentary | ON | 3 - 4 | ON (Mom.) | 3 - 2 | <p>SPDT + Anode - Cathode</p> |
| EE | SP Latching (Push-Push) | ON | 3 - 4 | ON | 3 - 2 | |

For SPST N.O. function, only terminals 3 & 2 are used.
 For SPST N.C. function, only terminals 3 & 4 are used.
 Circuit: Make before break

LED pins 1 & 5 are independent of switch function.

NOTE:
 For bi-color LED's the polarity must be reversed to alternate the color

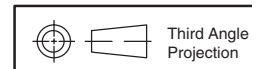
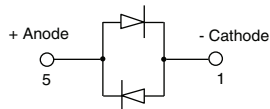

Dimensions are shown: Inches (mm)
 Specifications and dimensions subject to change



ELUM™ Series Right Angle Illuminated Latching Pushbutton

Pushbutton
A

TERMINAL STYLE



SA RIGHT ANGLE, SURFACE MOUNT

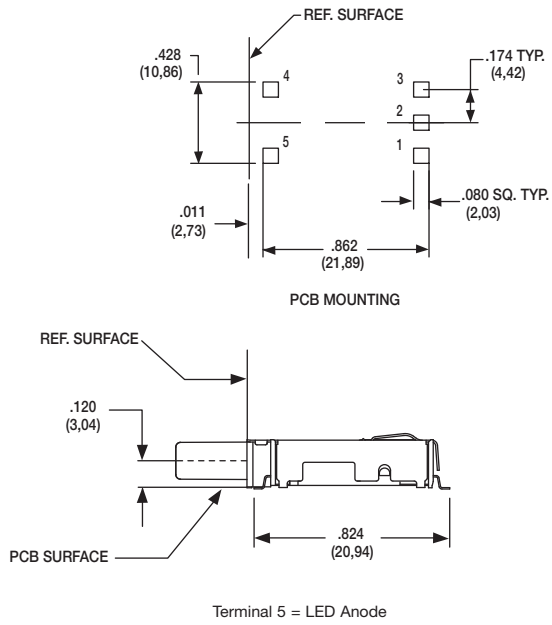

TH RIGHT ANGLE, PC THRU-HOLE

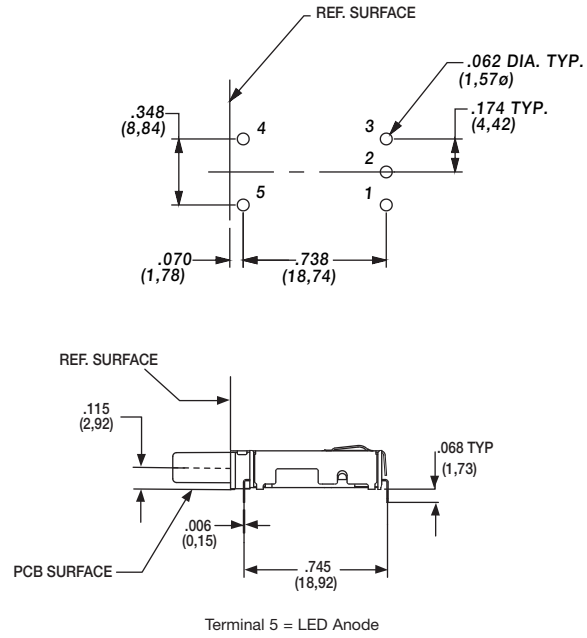

CONTACT MATERIAL



| OPTION CODE | CONTACT MATERIAL | TERMINAL PLATING | RATINGS |
|-------------|------------------------|------------------|---------|
| Q | SILVER WITH GOLD FLASH | SILVER | 250 mA |

* Note: See Technical Data section of this catalog for RoHS compliant and compatible definitions and specifications.

FIXED CONTACTS AND TERMINALS: Stainless steel, silver plated with gold flash

MOVABLE CONTACTS: Copper alloy, silver plated with gold flash

NOTE: Any models supplied with Q, contact material are RoHS compliant.

ILLUMINATION



| OPTION CODE | ILLUMINATION TYPE | TYPICAL INTENSITY* MIN | TYPICAL INTENSITY* MAX | PEAK WAVELENGTH | Vf Forward Voltage |
|-------------|------------------------------|---------------------------|---------------------------|-----------------|--------------------|
| | | (mcd) | | (nm) | |
| 0 | Model without illumination | N/A | | N/A | |
| 1 | LED Super White | 4,000 | 5,000 | N/A | 3.5 |
| 2 | LED Bi-Color – Red (Green) | 10 | 20 | 635/565 | 2.0 |
| 3 | LED Red | 4 | 8 | 700 | 2.0 |
| 5 | LED Amber | 35 | 50 | 610 | 2.0 |
| 6 | LED Green | 35 | 50 | 565 | 2.0 |
| 7 | LED Super Blue | 800 | 1,500 | 470 | 3.8 |
| 8 | LED Bi-Color – Amber (Green) | 10 | 10 | 585/565 | 2.0 |

*LED FORWARD CURRENT: 20 mA

LED FORWARD VOLTAGE: see chart above

LED REVERSE VOLTAGE: 5.0 V MAX

* For information on specific and custom LED, please contact Customer Service.

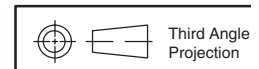

Dimensions are shown: Inches (mm)
Specifications and dimensions subject to change

ELUM™ Series Right Angle Illuminated Latching Pushbutton



A

Pushbutton

ACTUATOR STYLE*



C02 BLACK WITHOUT WINDOW

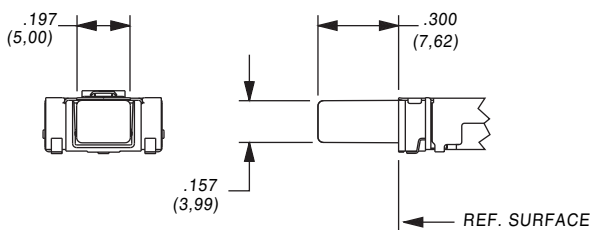

C12 BLACK WITH WINDOW

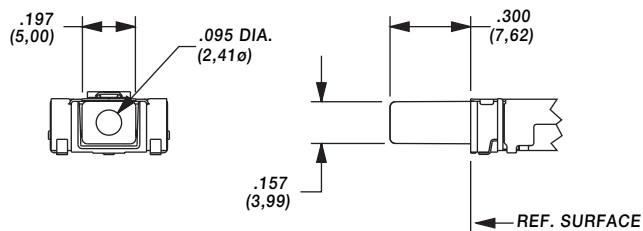

C22 BLACK WITH WINDOW AND SNAP FEATURE TO ACCEPT CUSTOM CAP

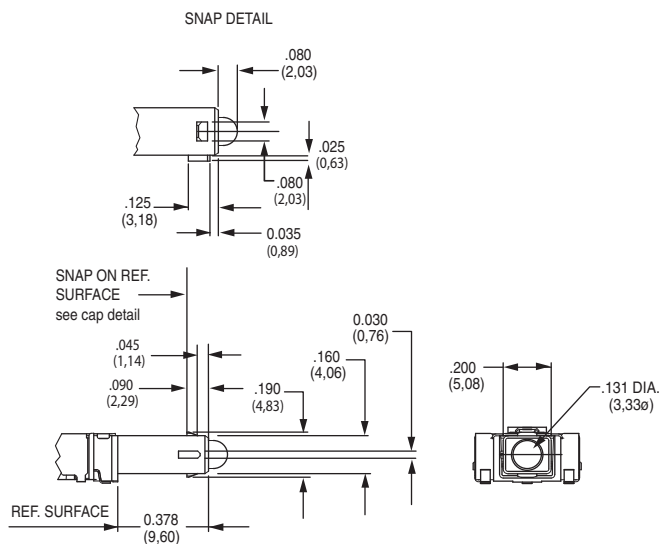

* Custom actuators available, please contact Customer Service.

FORCE TRAVEL DIAGRAM

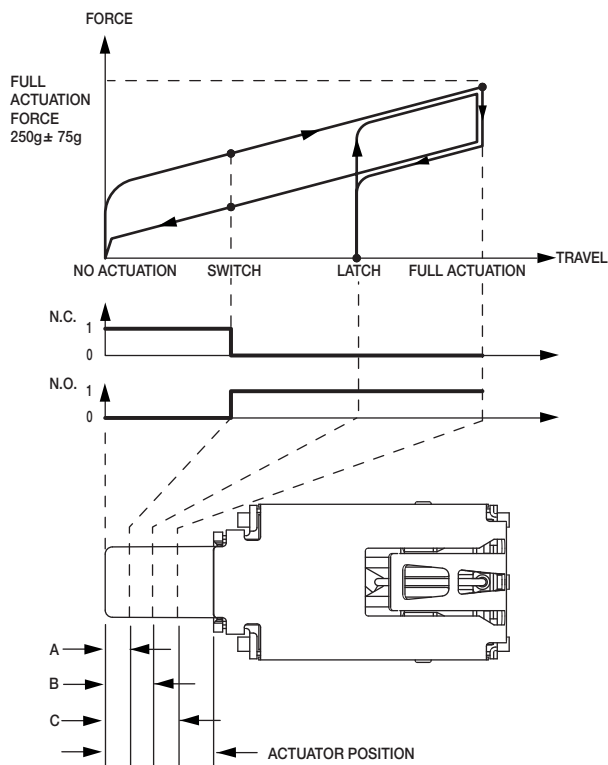

| OA, EE ACTUATOR POSITION | | | |
|--------------------------|----------------|-------------|-------------|
| A | SWITCH POINT | .067 ± .020 | 1,7 ± 0.5mm |
| B | LATCH | .131 ± .020 | 3,3 ± 0.5mm |
| C | FULL ACTUATION | .200 ± .020 | 5,1 ± 0.5mm |
| OC ACTUATOR POSITION | | | |
| A | SWITCH POINT | .067 ± .020 | 1,7 ± 0.5mm |
| C | FULL ACTUATION | .098 ± .020 | 2,5 ± 0.5mm |

TAPE & REEL

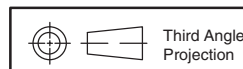
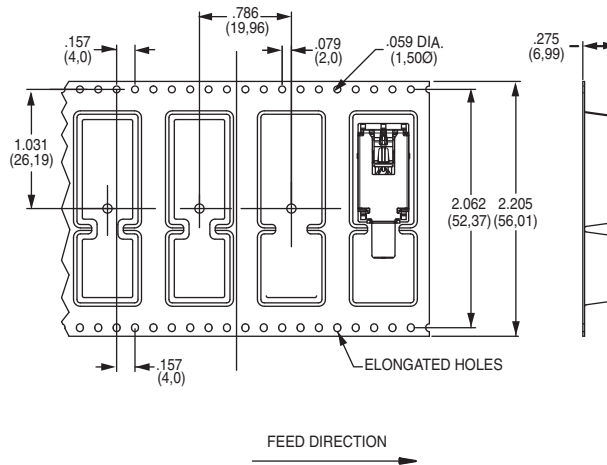

Third Angle
Projection



Dimensions are shown: Inches (mm)
Specifications and dimensions subject to change

www.ck-components.com



ELUM™ Series Right Angle Illuminated Latching Pushbutton

AVAILABLE HARDWARE

Pushbutton
A

Cap



PART NO.

957C00000 High temperature black cap with universal standby symbol

956C02000 High temperature black cap with no symbol

Material: 4/6 Nylon SMT compatible

Cap



PART NO.

181D01000 Paint and Laser Etched with black paint and universal standby symbol

Material: Clear polycarbonate

Cap



PART NO.

181D00000 Paint and laser etched with white paint underlay and black paint with universal standby symbol.

Material: Clear polycarbonate

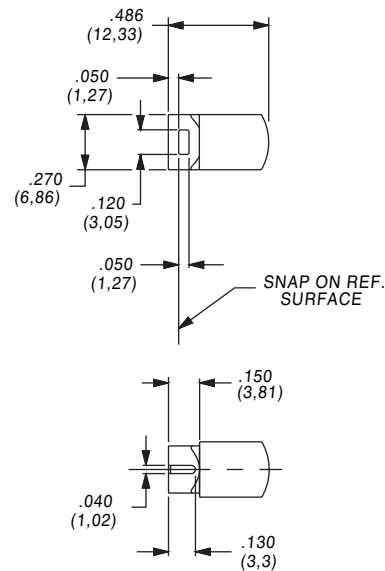

NOTE: Caps are for use with the C22 actuator style. Other colors and symbols available, consult Customer Service Center.

CAP INSTALLATION

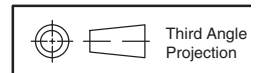
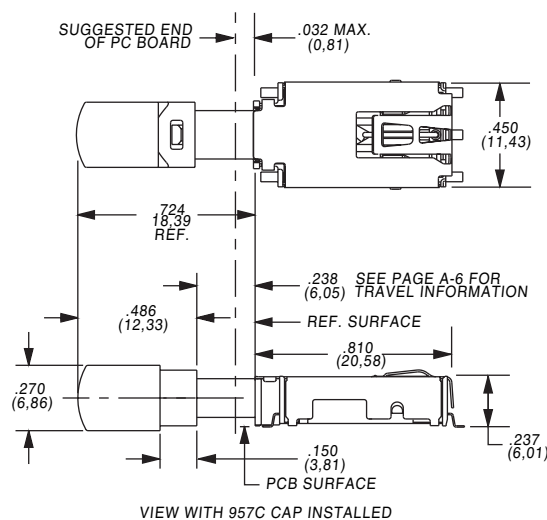

Dimensions are shown: Inches (mm)
Specifications and dimensions subject to change

www.ck-components.com

EP Series Sealed Tiny Pushbutton Switches

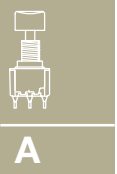

A
Pushbutton

Features/Benefits

- Sealed against solder & cleaning processes
- Thru-hole and surface mount models
- Snap-fitting actuator accepts standard caps
- Tape & reel packaging available
- RoHS compliant models available

Typical Applications

- Telecommunications and networking equipment
- Computers and peripherals
- Instrumentation and controls



Models Available

Specifications

CONTACT RATING: B contact material: 0.4 VA max. @ 20 V AC or DC max. See page A-13 for additional ratings.

ELECTRICAL LIFE: EP11, EP21 models: 60,000 make-and-break cycles at full load. EP12 models: 30,000 cycles.

CONTACT RESISTANCE: Below 20 mΩ typ. initial @ 2-4 V DC, 100 mA, for both silver and gold plated contacts.

INSULATION RESISTANCE: 10⁹ Ω min.

DIELECTRIC STRENGTH: 1000 Vrms min. @ sea level.

OPERATING TEMPERATURE: -30°C to 85°C.

SOLDERABILITY: Per MIL-STD-202F method 208D, or EIA RS-186E method 9 (1 hour steam aging).

DEGREE OF PROTECTION: IP57; Protection against harmful dust deposit, full-scale voltage protection, temporary immersion.

PACKAGING: Surface mount switches standard in anti-static tape and reel packaging per EIA 481-3, see page A-14 for drawings and reel information. Tape and cover strip are conductive for use near statically sensitive components, consult Customer Service Center.

Materials

CASE & BUSHING: High temperature material, glass filled nylon 4/6, flame retardant, heat stabilized (UL 94V-0) on EP11 / EP12 models; glass filled nylon 6/6 on EP21.

PLUNGER: Thermoplastic polyester or glass filled nylon (UL 94V-0), with internal o-ring seal. SA surface mount: High temperature material, glass filled LCP (UL 94V-0).

SWITCH SUPPORT: Brass, matte-tin plated.

CONTACTS & TERMINALS: B contact material: Copper alloy, with gold plate over nickel plate. See page A-13 for additional contact materials.

TERMINAL SEAL: Epoxy.

NOTE: Any models supplied with Q, B, P, S, R or G contact material are RoHS compliant.

NOTE: Specifications and materials listed above are for switches with standard options. For information on specific and custom switches, consult Customer Service Center.

CAUTION: PC mounting layouts and pads as shown are designed to be compatible with the latest equipment and reflow techniques. Care should be taken in the design and location of PC lands to suit individual needs. Orientation relative to reflow direction may significantly impact solder joint integrity.

Build-A-Switch

To order, simply select desired option from each category and place in the appropriate box. Available options are shown and described on pages A-10 thru A-14. For additional options not shown in catalog, consult Customer Service Center. All models are process sealed to withstand machine soldering temperatures and pressure wash cleaning methods.

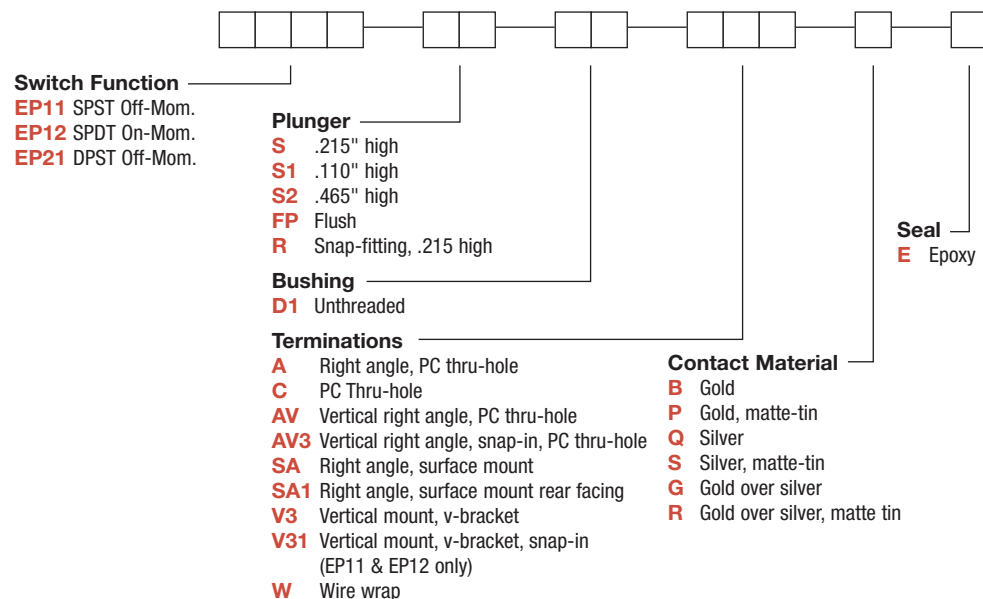

Dimensions are shown: Inches (mm)
Specifications and dimensions subject to change



EP Series Sealed Tiny Pushbutton Switches

Pushbutton A

SWITCH FUNCTION

| NO. POLES | MODEL NO. | SWITCH FUNCTION | | CONNECTED TERMINALS | | SCHEMATIC |
|--|-------------|-----------------|--------|---------------------|---------|-----------|
| | | POS. 1 | POS. 2 | POS. 1 | POS. 2 | |
| SP | EP11 | OFF | MOM. | OPEN | 1-3 | SPST |
| | EP12 | ON | MOM. | 2-1 | 2-3 | SPDT |
| SPDT <p>Part number shown: EP12SD1CBE</p> | | | | | | |
| DP | EP21 | OFF | MOM. | OPEN | 1-3,4-6 | DPST |
| DPST <p>Part number shown: EP21SD1CBE</p> | | | | | | |

MOM. = Momentary

All models with all options when ordered with G, Q, R or S contact material.

PLUNGER

S .215" HIGH

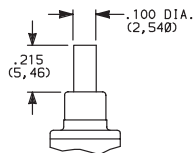

S1 .110" HIGH

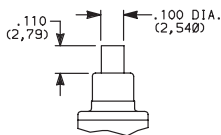

S2 .465" HIGH

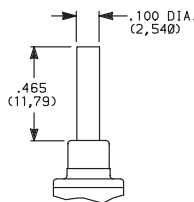

FP FLUSH PLUNGER

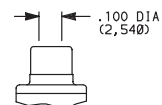

R SNAP-FITTING

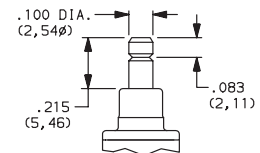

S1 & S2 actuators are not available with EP12 & EP21 models.

FP & R actuators are not available with EP21 model.

NOTE: Caps available for plunger options, see page A-14.

BUSHING

D1 UNTHREADED

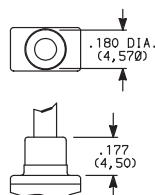

NOTE: Internal actuator o-ring standard.

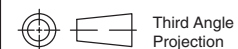

Dimensions are shown: Inches (mm)
Specifications and dimensions subject to change



EP Series Sealed Tiny Pushbutton Switches



A
Pushbutton

TERMINATIONS



C PC THRU-HOLE

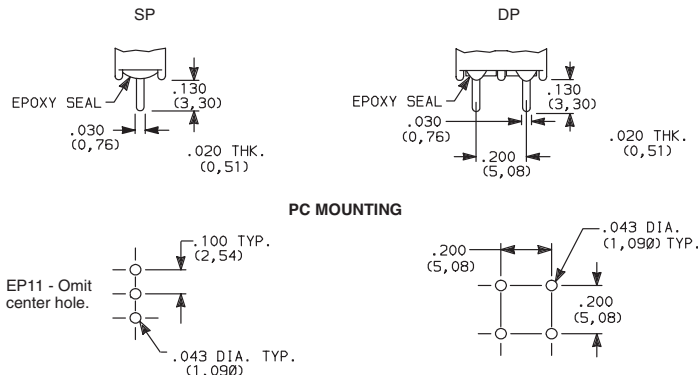

SP and DP

W WIRE WRAP

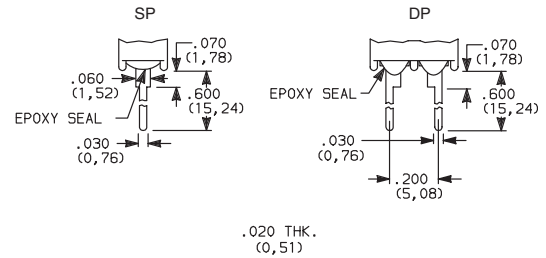

SP and DP

A RIGHT ANGLE, PC THRU-HOLE

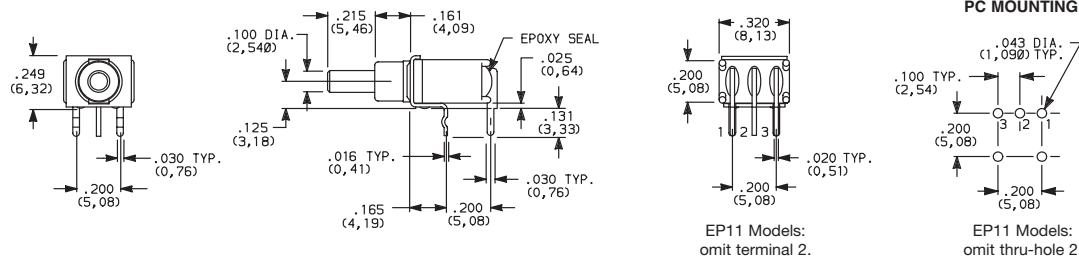

EP12SD1ABE
SPDT

EP11 Models:
omit terminal 2.

EP11 Models:
omit thru-hole 2.

A RIGHT ANGLE, PC THRU-HOLE

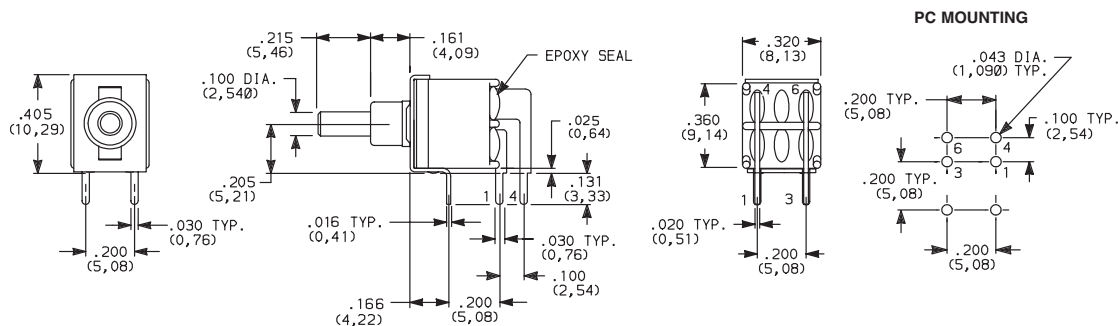

EP21SD1ABE
DPST

AV VERTICAL RIGHT ANGLE, PC THRU-HOLE

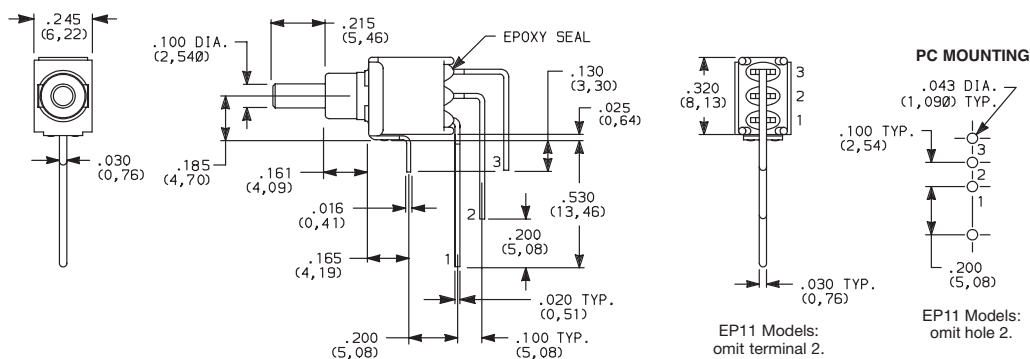

EP12SD1AVBE
SPDT

EP11 Models:
omit terminal 2.

EP11 Models:
omit hole 2.

NOTE: Terminal bend radii and lead-in manufacturing option.



Third Angle
Projection



Dimensions are shown: Inches (mm)
Specifications and dimensions subject to change



EP Series Sealed Tiny Pushbutton Switches

TERMINATIONS



Pushbutton

A

AV VERTICAL RIGHT ANGLE, THRU-HOLE



**EP21SD1AVBE
DPST**

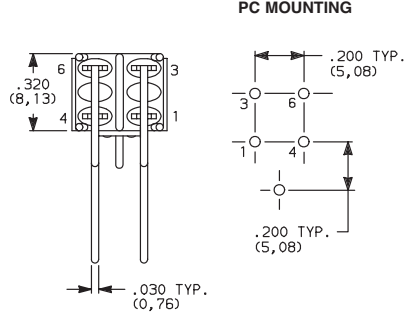
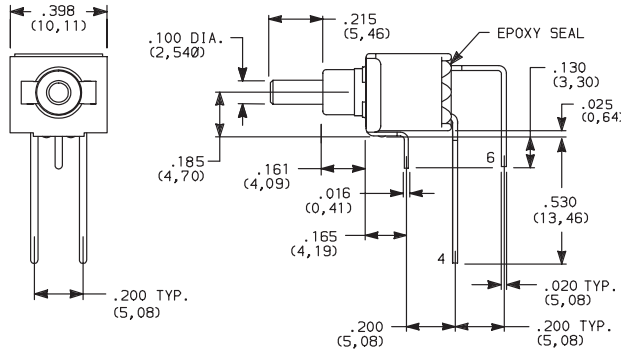

NOTE: Terminal bend radii and lead-in manufacturing option.

AV3 VERTICAL RIGHT ANGLE, SNAP-IN, PC THRU-HOLE



**EP12SD1AV3BE
SPST**

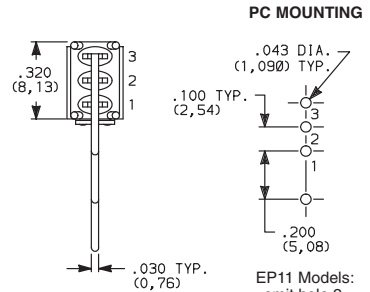
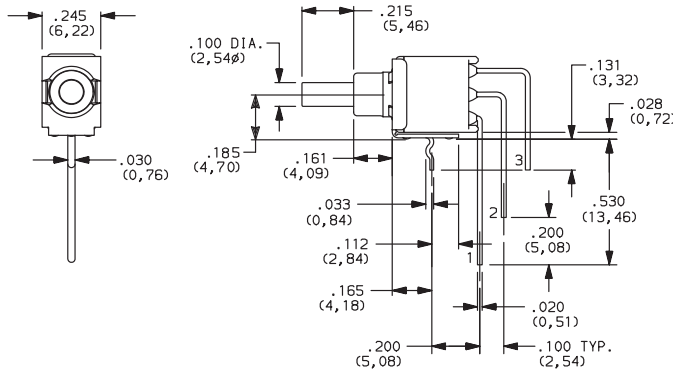

EP11 Models:
omit hole 2.

SA RIGHT ANGLE, SURFACE MOUNT



**EP12SD1SAPE
SPDT**

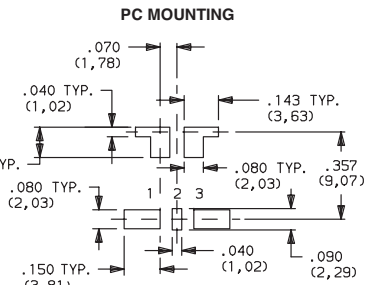
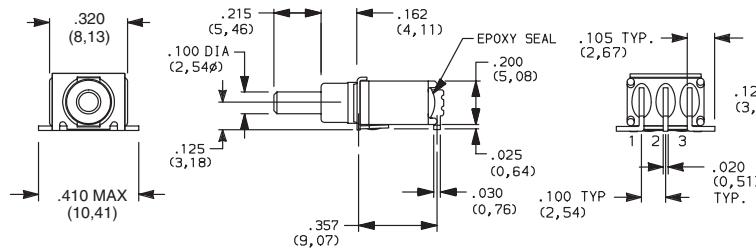

EP11 Models:
omit pad 2.

Available with P contact material only.
Not Available on DPST models.

EP11 Models:
omit terminal 2.

SA1 RIGHT ANGLE, SURFACE MOUNT



**EP12SD1SA1BE
SPDT**

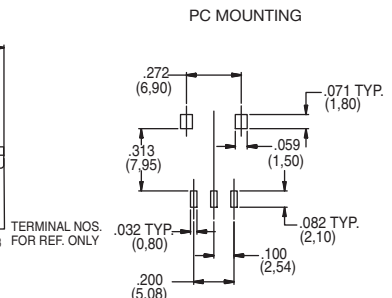
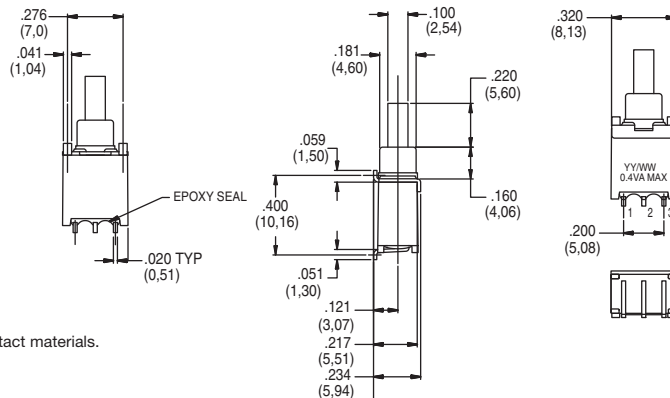

SA1 is only available with B and P contact materials.
Not Available on DPST models.

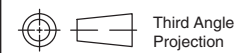

Dimensions are shown: Inches (mm)
Specifications and dimensions subject to change

www.ck-components.com

EP Series Sealed Tiny Pushbutton Switches



A

Pushbutton

TERMINATIONS

V3 VERTICAL MOUNT, V-BRACKET

V31 VERTICAL MOUNT, V-BRACKET, SNAP-IN

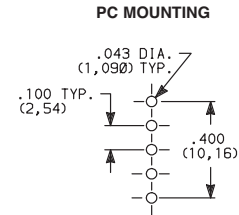
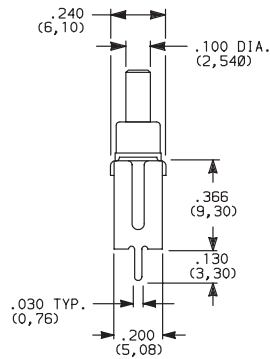
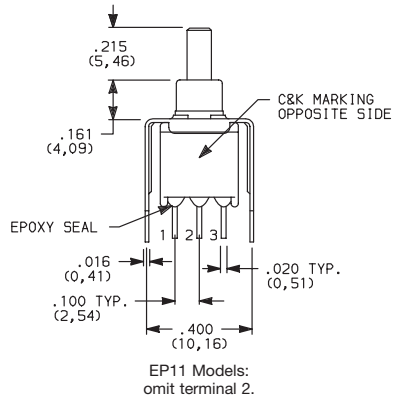

EP11 Models:
omit centerhole.

EP12SD1V3BE
SPDT



V3 VERTICAL MOUNT, V-BRACKET

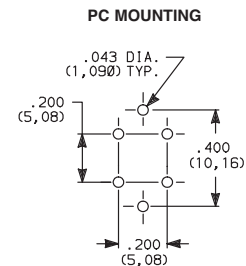
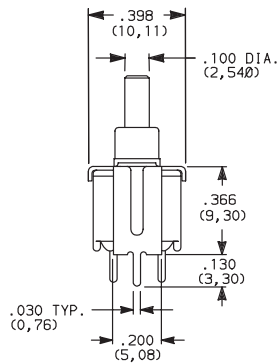
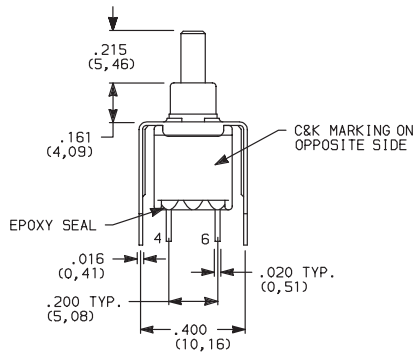

EP21SD1V3BE
DPST



CONTACT MATERIAL

| OPTION CODE | CONTACT MATERIAL | TERMINAL PLATING | RATINGS | |
|-------------|---------------------------------|------------------------|--------------------------------|--|
| B | GOLD ¹ | GOLD ¹ | LOW LEVEL/DRY CIRCUIT | 0.4 VA MAX. @ 20 V AC OR DC MAX. |
| P | | MATTE-TIN ⁶ | | |
| Q | SILVER ^{4,5} | SILVER ⁵ | POWER | 1 AMP @ 120 V AC OR 28 V DC. |
| S | | MATTE-TIN ⁶ | | |
| G | GOLD OVER SILVER ^{2,3} | GOLD ³ | LOW LEVEL/DRY CIRCUIT OR POWER | 0.4 VA MAX @ 20 V AC OR DC MAX. OR 1 AMP @ 120 V AC OR 28 V DC. |
| R | | MATTE-TIN ⁶ | | |

* Note: See Technical Data section of this catalog for RoHS compliant and compatible definitions and specifications.

¹ CONTACTS & TERMINALS: Copper alloy, with gold plate over nickel plate.

² END CONTACTS: Coin silver, with gold plate over nickel plate.

³ CENTER CONTACTS & ALL TERMINALS: Copper alloy, with gold plate over nickel plate.

⁴ END CONTACTS: Coin silver, silver plated.

⁵ CENTER CONTACT & ALL TERMINALS: Copper alloy, silver plated.

⁶ TERMINALS: Copper alloy, with matte tin over nickel plate.

NOTE: Any models supplied with Q, B, P, S, R or G contact material are RoHS compliant.

All models  with all options when ordered with G, S, R or Q contact material.

SEAL

E EPOXY SEAL

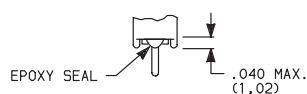

Dimensions are shown: Inches (mm)
Specifications and dimensions subject to change



EP Series Sealed Tiny Pushbutton Switches

Pushbutton
A

AVAILABLE HARDWARE

Cap

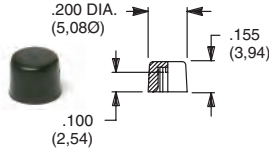

PART NO.

- 508101000 WHITE
- 508102000 BLACK
- 508103000 RED

Material: Nylon
Finish: Gloss

Not for use on S1 plunger

Cap

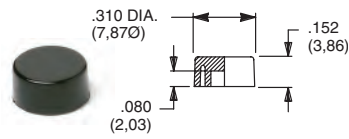

PART NO.

- 465801000 WHITE
- 465802000 BLACK
- 465803000 RED

Material: Nylon
Finish: Gloss

Not for use on S1 plunger

Cap

Compatible with snap-fitting plungers
EP11 & EP12 Models. R option only.

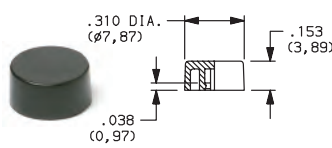

PART NO.

- 585A01000 WHITE
- 585A02000 BLACK
- 585A03000 RED

Material: Nylon
Finish: Gloss

Cap

Compatible with snap-fitting plungers
EP11 & EP12 Models. R option only.

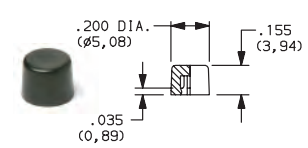

PART NO.

- 785A01000 WHITE
- 785A02000 BLACK
- 785A03000 RED

Material: Nylon
Finish: Gloss

NOTE: Other colors available, consult Customer Service Center.

TAPE & REEL

For part number EPXX-SA/SA1

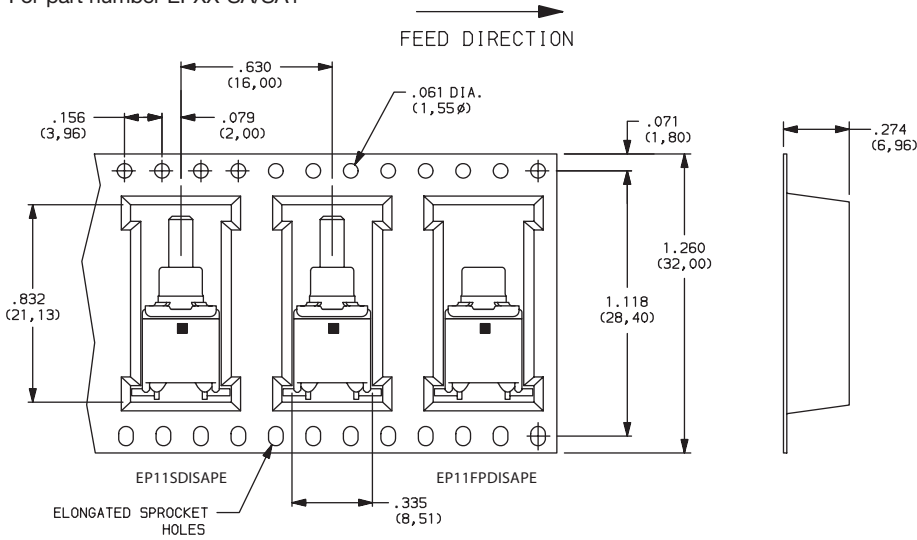

| REEL INFORMATION | |
|-------------------|---------------|
| OUTSIDE DIAMETER | 13.00 (330,0) |
| PILOT HOLE | .512 (13,0) |
| QUANTITY PER REEL | 600 |



Dimensions are shown: Inches (mm)
Specifications and dimensions subject to change

TP Series Tiny Pushbutton Switches



A
Pushbutton

Features/Benefits

- **Subminiature size**—capable of switching 1 AMP
- **Vertical & right angle terminations**
- **PC & panel mount models**
- **Snap-in front panel mounting available**
- **Epoxy terminal seal-compatible with bottom wash cleaning**
- **RoHS compliant models available**



Models Available

Typical Applications

- **Telecommunications and networking equipment**
- **Computers and peripherals**
- **Instrumentation and controls**



Specifications

CONTACT RATING: B contact material: 0.4 VA max. @ 20 V AC or DC max. Q contact material: 1 AMP @ 120 V AC or 28 V DC. See page A-19 for additional ratings.

ELECTRICAL LIFE: TP11, TP21 MODELS: 60,000 make-and-break cycles at full load. TP12 MODELS: 30,000 cycles.

CONTACT RESISTANCE: Below 20 mΩ typ. initial @ 2-4 V DC, 100 mA, for both silver and gold plated contacts.

INSULATION RESISTANCE: 10⁹Ω min.

DIELECTRIC STRENGTH: 1000 Vrms min. @ sea level.

OPERATING TEMPERATURE: -30°C to 85°C.

SOLDERABILITY: Per MIL-STD-202F method 208D, or EIA RS-186E method 9 (1 hour steam aging).

NOTE: Any models supplied with Q, B, P, R or G contact material are RoHS compliant.

NOTE: Specifications and materials listed above are for switches with standard options. For information on specific and custom switches, consult Customer Service Center.

Materials

CASE: Glass filled nylon 4/6 or 6/6, flame retardant, heat stabilized or diallyl phthalate (DAP), (UL 94V-0).

PLUNGER: Thermoplastic polyester (UL 94V-0).

CAP & FRAME: Nylon, black standard.

BUSHING: Brass, nickel plated.

HOUSING: Stainless steel.

SWITCH SUPPORT: Brass, matte-tin plated.

END CONTACTS: B contact material: Copper alloy, with gold plate over nickel plate. Q contact material: Coin silver, silver plated. See page A-19 for additional contact materials.

CENTER CONTACT & ALL TERMINALS: B contact material: Copper alloy, with gold plate over nickel plate. Q contact material: Copper alloy, silver plated. See page A-19 for additional contact materials.

TERMINAL SEAL: Epoxy. Refer to soldering and cleaning in Technical Data Chapter

HARDWARE: Nut & Locking Ring: Brass nickel plated.
Lockwasher: Steel, nickel plated.

Build-A-Switch

To order, simply select desired option from each category and place in the appropriate box. Available options are shown and described on pages A-16 thru A-20. For additional options not shown in catalog, consult Customer Service Center. All models have epoxy terminal seal and are compatible with all "bottom-wash" PCB cleaning methods.

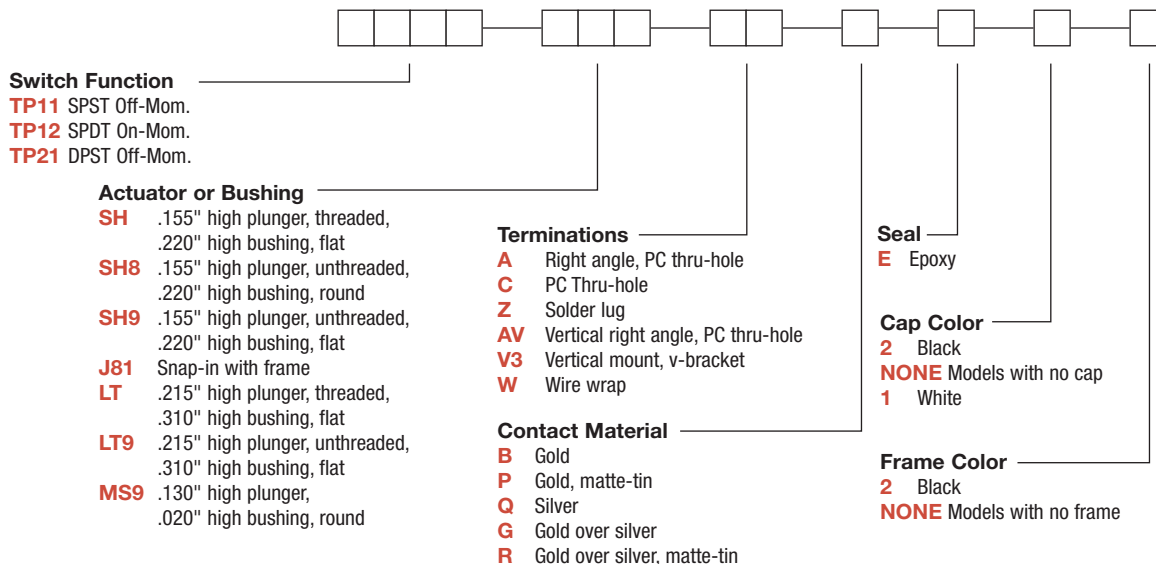

Dimensions are shown: Inches (mm)
Specifications and dimensions subject to change



TP Series Tiny Pushbutton Switches

Pushbutton
A

SWITCH FUNCTION

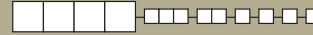

| NO. POLES | MODEL NO. | SWITCH FUNCTION | | CONNECTED TERMINALS | | SCHEMATIC |
|-----------------|-------------|-----------------|--------|---------------------|---------|------------------------------|
| | | POS. 1 | POS. 2 | POS. 1 | POS. 2 | |
| SP | TP11 | OFF | MOM. | OPEN | 1-3 | SPST 1 2 3 |
| | TP12 | ON | MOM. | 2-1 | 2-3 | SPDT NC 1 2 (COMMON) 3 NO |
| SPDT | | | | | | |
| DP | TP21 | OFF | MOM. | OPEN | 1-3,4-6 | DPST 1 3 4 6 |
| DPST | | | | | | |

MOM. = Momentary

All models with all options when ordered with G, Q or R contact material.

ACTUATOR—SNAP-IN FRONT MOUNT

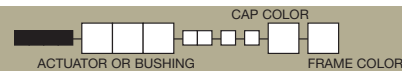

J81 SNAP-IN WITH FRAME

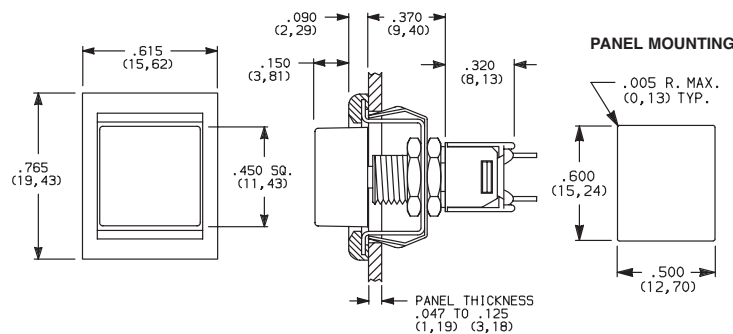

| OPTION CODE | CAP COLOR |
|-------------|-----------|
| 2 | BLACK |
| 1 | WHITE |

| OPTION CODE | FRAME COLOR |
|-------------|-----------------------------|
| 2 | BLACK |
| NONE | No Frame Color (J80 option) |

Cap and Frame Finish: matte. Other colors available, consult Customer Service Center.
NOTE: Available with Z, C, or W terminations.

NOTE: Caps & frames available separately, see page A-20.



Dimensions are shown: Inches (mm)
 Specifications and dimensions subject to change



TP Series Tiny Pushbutton Switches



A

Pushbutton

SH .155" HIGH PLUNGER,
.220" HIGH BUSHING,
THREADED, FLAT

SH8 .155" HIGH PLUNGER,
.220" HIGH BUSHING,
UNTHREADED

SH9 .155" HIGH PLUNGER,
.220" HIGH BUSHING,
UNTHREADED, FLAT

LT .215" HIGH PLUNGER,
.310" HIGH BUSHING,
THREADED

MS9 .130" HIGH
PLUNGER

LT9 .215" HIGH PLUNGER,
.310" HIGH BUSHING,
UNTHREADED

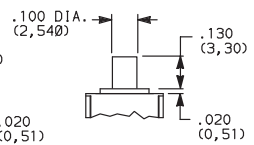
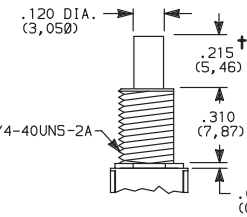
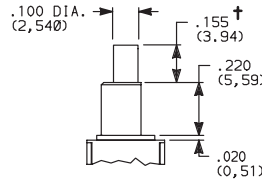
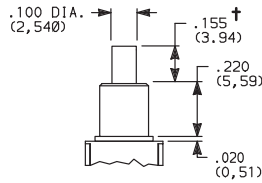
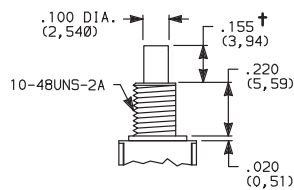
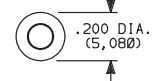
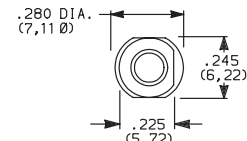
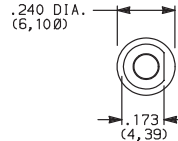
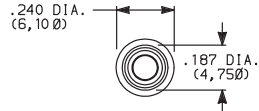
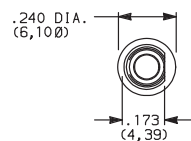

Standard with Z, C, W terminations.

Standard with A, AV, V3 terminations.

Not available with Z terminations.

† Subtract .016 (0,41) for models with A, AV or V3 terminations.

NOTE: Caps available for plunger options, see page A-20.

PANEL MOUNTING

10-48 BUSHING

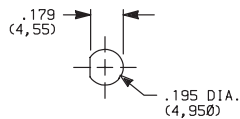

Without locking ring

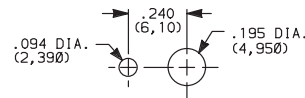

With standard locking ring

1/4 IN. BUSHING

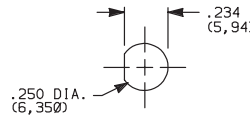

Without locking ring

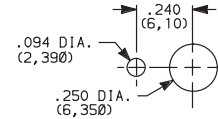

With standard locking ring

NOTE: One mounting nut, locking ring and lockwasher supplied standard with 10-48 threaded bushings (two nuts with 1/4-40 bushings). Optional mounting nut and locking ring styles and finishes available separately, see section "Technical Data and Additional Hardware".

TERMINATIONS

C PC THRU-HOLE

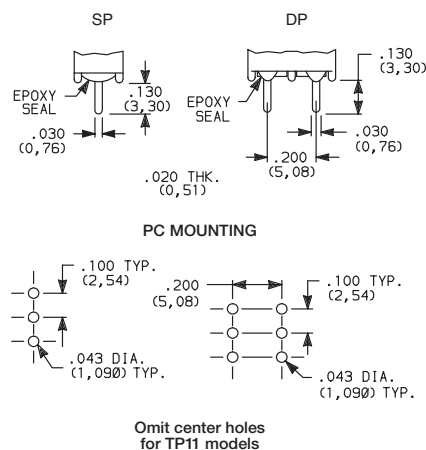

Z SOLDER LUG

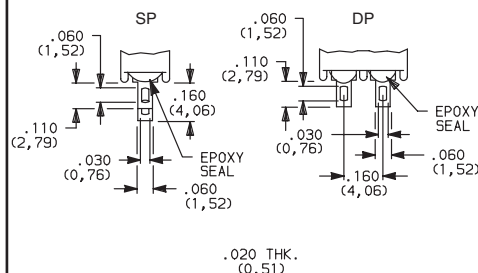

Not available with MS9 bushing or P or R contact material.

W WIRE WRAP

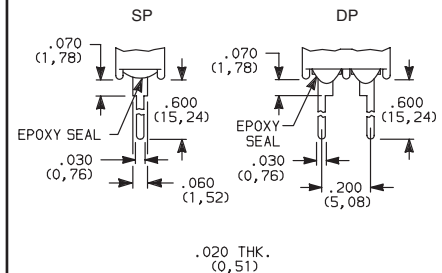

Third Angle Projection

Dimensions are shown: Inches (mm)
Specifications and dimensions subject to change



www.ck-components.com



TP Series Tiny Pushbutton Switches

TERMINATIONS



Pushbutton

A

A RIGHT ANGLE, PC THRU-HOLE



**TP12SH9ABE
SPDT**

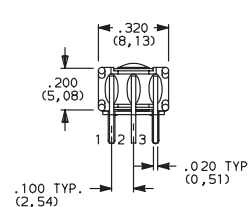
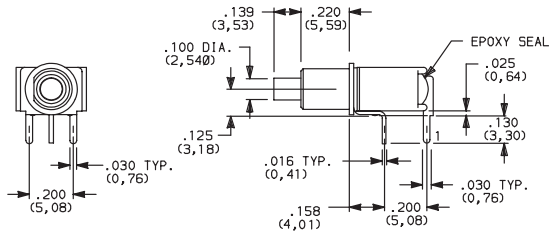

**TP11 Models:
omit terminal 2.**

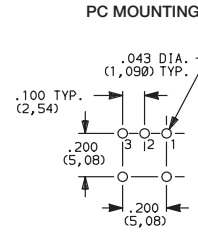

**TP11 Models:
omit hole 2.**

A RIGHT ANGLE, PC THRU-HOLE



**TP21SH9ABE
DPST**

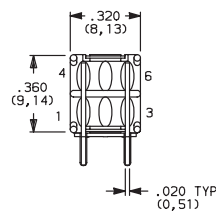
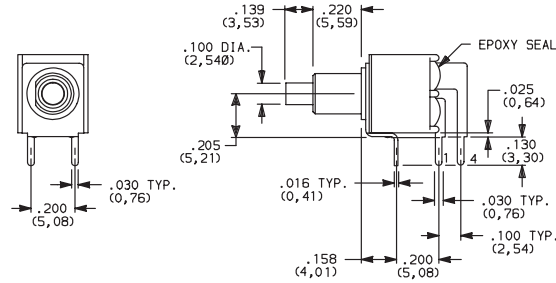

PC MOUNTING

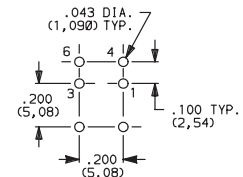

AV VERTICAL RIGHT ANGLE, PC THRU-HOLE



**TP12SH9AVBE
SPDT**

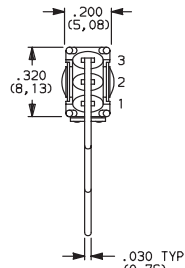
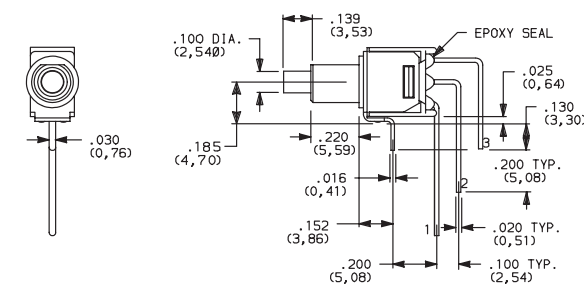

PC MOUNTING

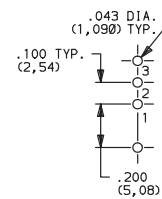

**TP11 Models:
omit hole 2.**

**TP11 Models:
omit terminal 2.**

NOTE: Terminal bend radii and lead-in manufacturing option.

AV VERTICAL RIGHT ANGLE, PC THRU-HOLE



**TP21SH9AVBE
DPST**

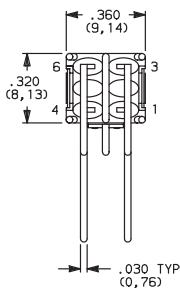
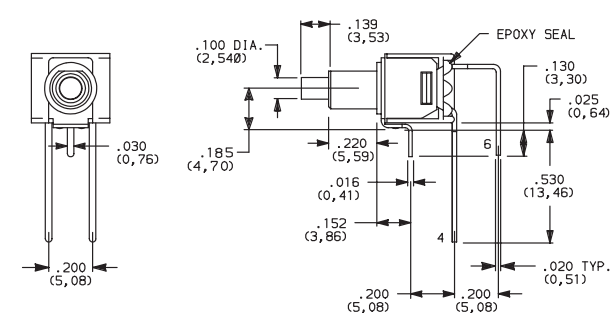

PC MOUNTING

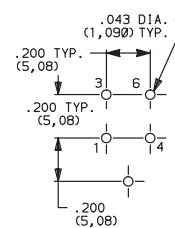

NOTE: Terminal bend radii and lead-in manufacturing option.



Dimensions are shown: Inches (mm)
Specifications and dimensions subject to change

TP Series Tiny Pushbutton Switches



A

Pushbutton

TERMINATIONS

V3 VERTICAL MOUNT, V-BRACKET

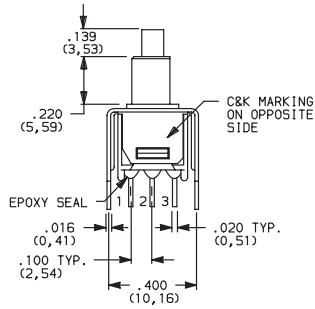

TP11 Models:
omit terminal 2.

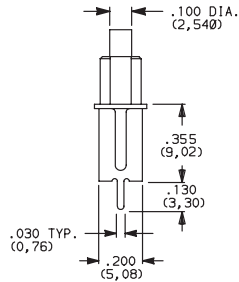

PC MOUNTING

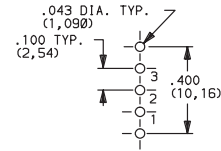

TP11 Models:
omit hole 2.



TP12SH9V3BE
SPDT

V3 VERTICAL MOUNT, V-BRACKET

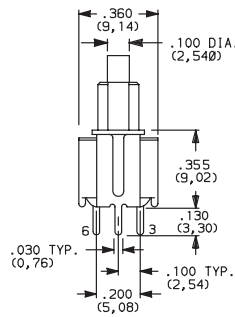
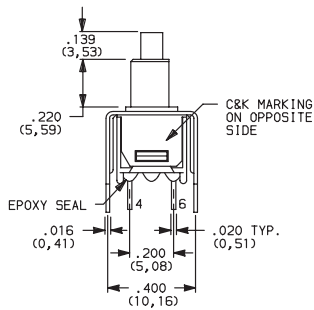

PC MOUNTING

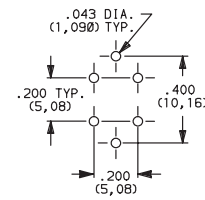

TP21SH9V3BE
DPST

CONTACT MATERIAL

| OPTION CODE | CONTACT MATERIAL | TERMINAL PLATING | RATINGS | |
|-------------|---------------------------------|------------------------|--------------------------------|--|
| B | GOLD ¹ | GOLD ¹ | LOW LEVEL/DRY CIRCUIT | 0.4 VA MAX. @ 20 V AC OR DC MAX. |
| P | | MATTE-TIN ⁶ | | |
| Q | SILVER ^{4,5} | SILVER ⁵ | POWER | 1 AMP @ 120 V AC OR 28 V DC. |
| G | GOLD OVER SILVER ^{2,3} | GOLD ³ | LOW LEVEL/DRY CIRCUIT OR POWER | 0.4 VA MAX @ 20 V AC OR DC MAX. OR 1 AMP @ 120 V AC OR 28 V DC. |
| R | | MATTE-TIN ⁶ | | |

* Note: See Technical Data section of this catalog for RoHS compliant and compatible definitions and specifications.

¹ CONTACTS & TERMINALS: Copper alloy, with gold plate over nickel plate.

² END CONTACTS: Coin silver, with gold plate over nickel plate.

³ CENTER CONTACTS & ALL TERMINALS: Copper alloy, with gold plate over nickel plate.

⁴ END CONTACTS: Coin silver, silver plated.

⁵ CENTER CONTACT & ALL TERMINALS: Copper alloy, silver plated.

⁶ TERMINALS: Copper alloy, with matte-tin over nickel plate.

NOTE: Any models supplied with P, R, Q, B or G contact material are RoHS compliant.

All models with all options when ordered with R, G, or Q contact material.

B contact material standard with A, AV, V3 & W terminations.

Q contact material standard with C & Z terminations

P, R contact materials not available with Z terminations.

SEAL

E EPOXY SEAL

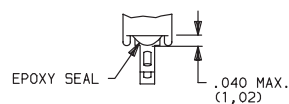

Third Angle
Projection



Dimensions are shown: Inches (mm)
Specifications and dimensions subject to change



TP Series Tiny Pushbutton Switches

Pushbutton
A

AVAILABLE HARDWARE

Cap, .100" DIA. Plungers

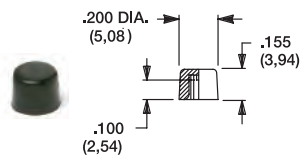

PART NO.
508101000 WHITE
508102000 BLACK
 Material: Nylon
 Finish: Gloss

Cap, .100" DIA. Plungers
(Recommended for S9 plunger)

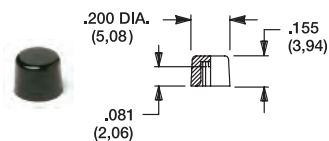

PART NO.
538701000 WHITE
538702000 BLACK
 Material: Nylon
 Finish: Gloss

Cap, .100" DIA. Plungers

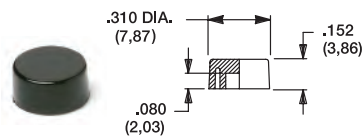

PART NO.
465801000 WHITE
465802000 BLACK
 Material: Nylon
 Finish: Gloss

Cap, .120" DIA. Plungers

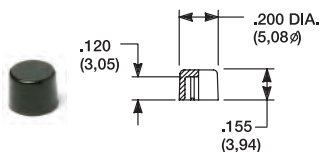

PART NO.
708901000 WHITE
708902000 BLACK
 Material: Nylon
 Finish: Gloss

Cap, .120" DIA. Plungers

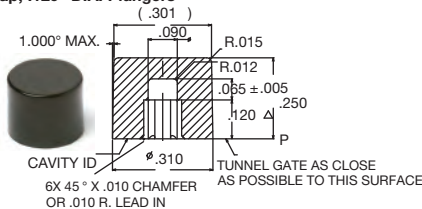

PART NO.
891D01000 WHITE
891D02000 BLACK
 Material: Nylon
 Finish: Gloss

Cap, J81 option only

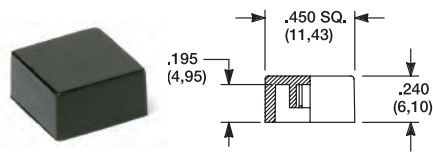

PART NO.
484601000 WHITE
484602000 BLACK
 Material: Nylon
 Finish: Gloss

PART NO.
798201000 WHITE
798202263 BLACK
 Material: Nylon
 Finish: Matte

NOTE: Additional nuts, locking rings and lockwashers available separately, see section "Technical Data and Additional Hardware".
 Other cap colors available, consult Customer Service Center.

Frames snap into panel opening and are independent from switch mounting. Accurate positioning of the PC mounted switch relative to the panel opening is necessary to provide proper clearance between actuator and frame. Available in two basic styles and four panel thicknesses .047-.125 in. Material: Nylon. Finish: Matte.

TYPICAL APPLICATION

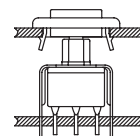

.047" (1,19) PANEL THK. .062" (1,57) PANEL THK. .090" (2,29) PANEL THK. .125" (3,18) PANEL THK.

PART NO. **PART NO.** **PART NO.** **PART NO.**
432502263 **432602263** **432702263** **432802263** BLACK

PANEL MOUNTING

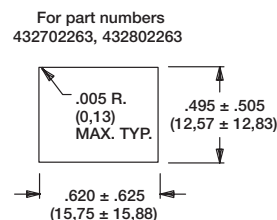
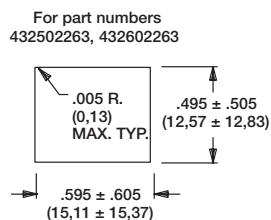

Panel Inserts

L.E.D. (.200 DIA. (5,08)) SNAPS SECURELY INTO INSERT (P/N 8949). HEIGHT DEPENDS ON L.E.D. USED.

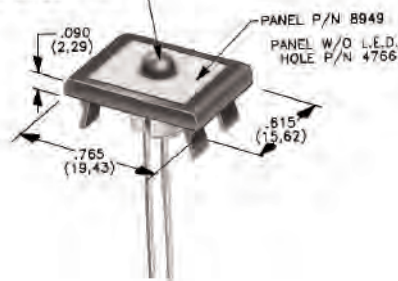

Above frames (part nos. 432XXXXXX) are also available with insert which accepts LED for indicator light assembly. Order insert separately from frame. Blank insert panel (without hole for LED) also available. **LED not included.**

PANEL INSERT WITH HOLE FOR LED

PART NO.
894902000

BLANK PANEL INSERT WITHOUT HOLE FOR LED

PART NO.
476602000 BLACK

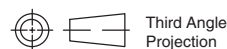

Dimensions are shown: Inches (mm)
 Specifications and dimensions subject to change

E020 Series Sealed Snap-acting Momentary Pushbutton Switches



A

Pushbutton

Features/Benefits

- Process sealed with disposable splashproof boot
- Long life contact design
- Snap-fitting plunger available
- RoHS compliant models available

Typical Applications

- Instrumentation
- Telecommunications and networking equipment
- Computers and peripherals



Models Available

Specifications

CONTACT RATING: B contact material (EX25 Models): 0.4 VA max. @ 20 V AC or DC max. G contact material (EX21 Models): 1 AMP @120 V AC or 28 V DC or 0.4 VA max. @ 20 V AC or DC max. Note: Break-before-make contacts. Multi-pole contacts do not make and break simultaneously. See page A-26 for additional ratings.

ELECTRICAL LIFE: 60,000 make-and-break cycles at full load.

CONTACT RESISTANCE: Below 50 mΩ typ. initial @ 2-4 V DC, 100 mA, for both silver and gold plated contacts.

INSULATION RESISTANCE: 10⁹Ω min.

DIELECTRIC STRENGTH: 1000 Vrms min. @ sea level.

OPERATING TEMPERATURE: -30°C to 75°C.

CAP INSTALLATION FORCE: 10 lbs. max. permissible.

SOLDERABILITY: Per MIL-STD-202F method 208D, or

EIA RS-186E method 9 (1 hour steam aging).

NOTE: Any models supplied with P, R, B or G contact material are RoHS compliant.

NOTE: Specifications and materials listed above are for switches with standard options. For information on specific and custom switches, consult Customer Service Center.

Materials

CASE & BUSHING: Glass filled nylon 6/6, flame retardant (UL 94V-0).

PLUNGER: Glass filled nylon or glass filled polyester (PBT) (UL 94V-0).

SWITCH SUPPORT: Brass or steel, matte-tin.

SWITCH SUPPORT RETAINER: Stainless steel.

N.O. & N.C. CONTACTS: EX25 MODELS: B contact material: Copper alloy, with gold plate over nickel plate. EX21 MODELS: G contact material: Coin silver, with gold plate over nickel plate. See page A-26 for additional contact materials.

COMMON CONTACTS & ALL TERMINALS: Copper alloy, with gold plate over nickel plate. See page A-26 for additional contact materials.

TERMINAL SEAL: Epoxy.

DISPOSABLE BOOT: Vinyl splashproof boot supplied standard. Remove and discard only after soldering and cleaning processes are complete.

Build-A-Switch

To order, simply select desired option from each category and place in the appropriate box. Available options are shown and described on pages A-22 thru A-28. For additional options not shown in catalog, consult our Customer Service Center. All models are process sealed to withstand machine soldering temperatures and pressure wash cleaning methods.

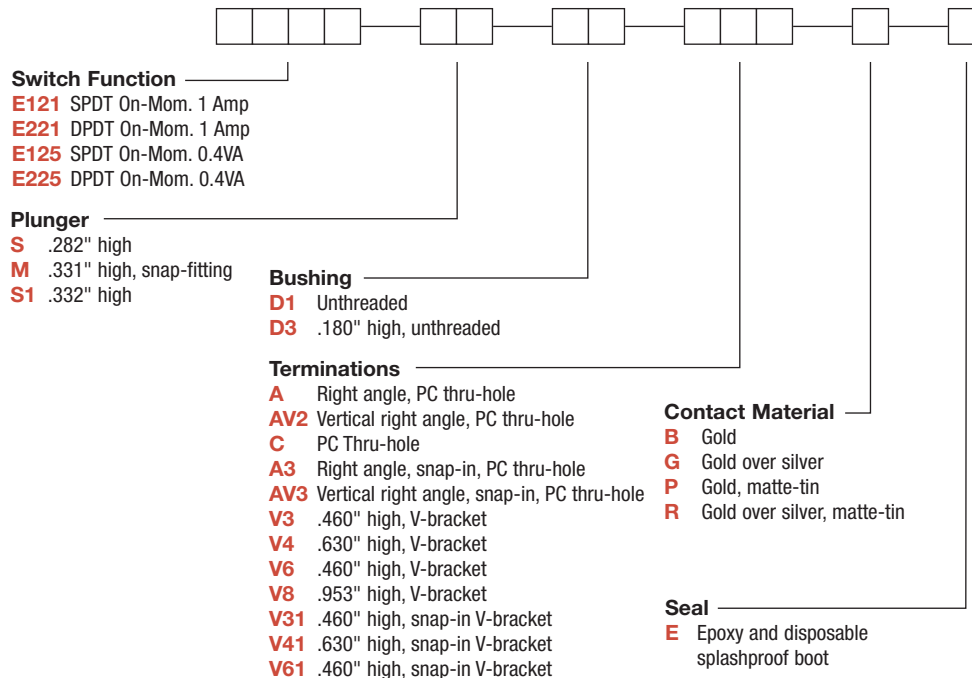

Dimensions are shown: Inches (mm)
Specifications and dimensions subject to change



E020 Series Sealed Snap-acting Momentary Pushbutton Switches

Pushbutton
A

SWITCH FUNCTION

| NO. POLES | MODEL NO. | SWITCH FUNCTION | | CONNECTED TERMINALS | | SCHEMATIC |
|--|-----------|-----------------|--------|---------------------|---------|-----------|
| | | POS. 1 | POS. 2 | POS. 1 | POS. 2 | |
| SP | E121 | ON | MOM. | 1-3 | 1-2 | |
| | E125 | ON | MOM. | 1-3 | 1-2 | |
| SPDT <p>Part number shown: E121SD1CGE</p> | | | | | | |
| DP | E221 | ON | MOM. | 1-3,4-6 | 1-2,4-5 | |
| | E225 | ON | MOM. | 1-3,4-6 | 1-2,4-5 | |
| DPDT <p>Part number shown: E221SD1CBE</p> | | | | | | |

MOM. = Momentary

E121, E221 models with all options when ordered with G or R contact material.

EX25 models must be ordered with B or P contact material.
EX21 models must be ordered with G or R contact material.

PLUNGER

S .282" HIGH

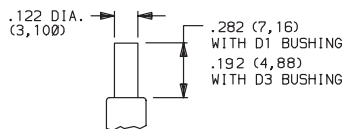

S1 .332" HIGH

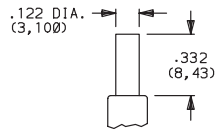

Not Available with D1 bushing.

M .332" HIGH SNAP-FITTING

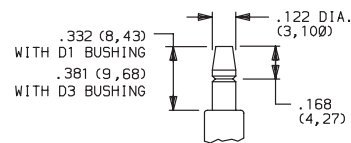

NOTE: Caps available for all plunger options, see page A-27.

BUSHING

D1 UNTHREADED

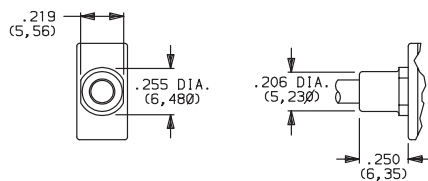

Not available with S1 actuator.

D3 .180" HIGH UNTHREADED

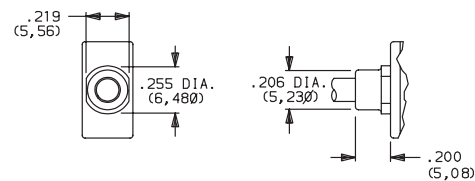

NOTE: Disposable splashproof vinyl over actuator and bushing supplied std., see page A-26.

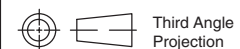

Dimensions are shown: Inches (mm)
Specifications and dimensions subject to change

E020 Series Sealed Snap-acting Momentary Pushbutton Switches



A

Pushbutton

TERMINATIONS

C PC THRU-HOLE

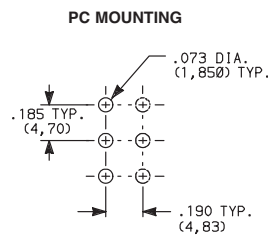
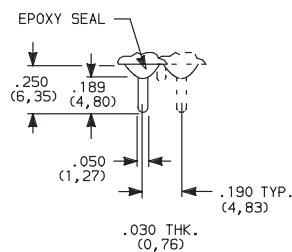

SPDT and DPDT

A RIGHT ANGLE, PC THRU-HOLE

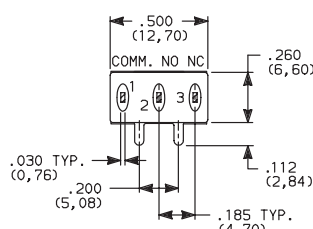
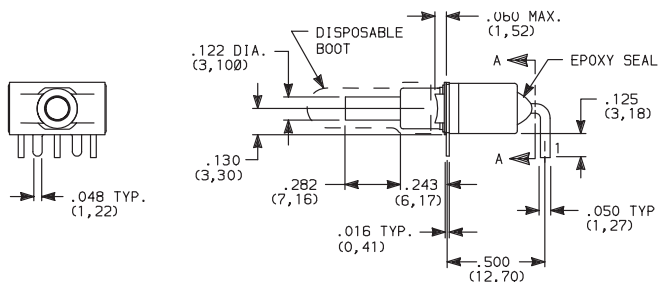

E121SD1AGE
SPDT

A3 RIGHT ANGLE, SNAP-IN, PC THRU-HOLE

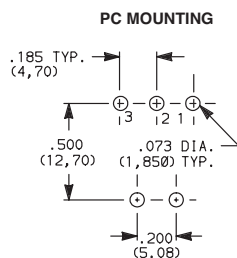

NOTE: Terminal bend radii and lead-in manufacturing option.

A RIGHT ANGLE, PC THRU-HOLE

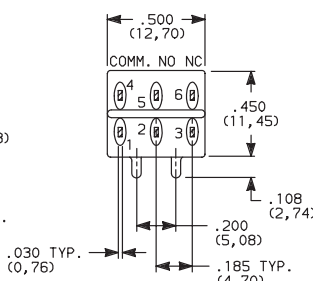
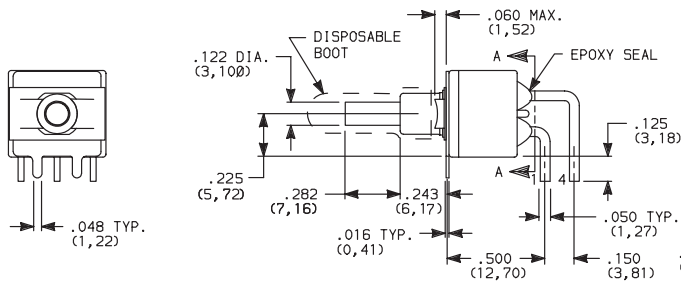

E221SD1AGE
DPDT

A3 RIGHT ANGLE, SNAP-IN, PC THRU-HOLE

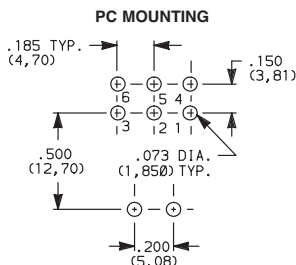

NOTE: Terminal bend radii and lead-in manufacturing option.



Dimensions are shown: Inches (mm)
Specifications and dimensions subject to change





E020 Series Sealed Snap-acting Momentary Pushbutton Switches

TERMINATIONS



Pushbutton
A

AV2 VERTICAL RIGHT ANGLE, PC THRU-HOLE,
.150" PITCH

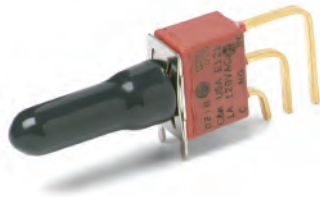

**E121SD1AV2GE
SPDT**

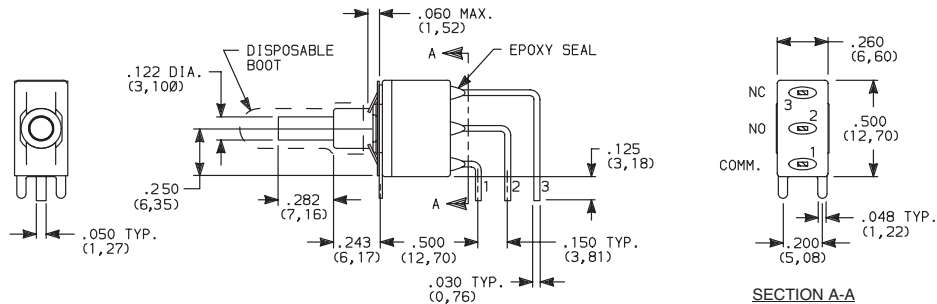

AV3 VERTICAL RIGHT ANGLE, SNAP-IN, PC THRU-HOLE,
.150" PITCH

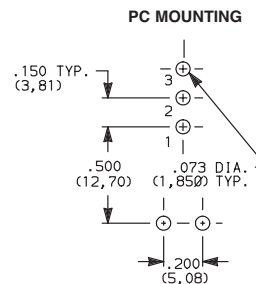
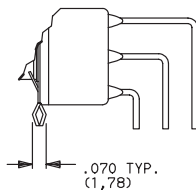
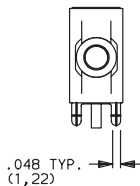

NOTE: Terminal bend radii and lead-in manufacturing option.

AV2 VERTICAL RIGHT ANGLE, PC THRU-HOLE,
.150" PITCH



**E221SD1AV2GE
DPDT**

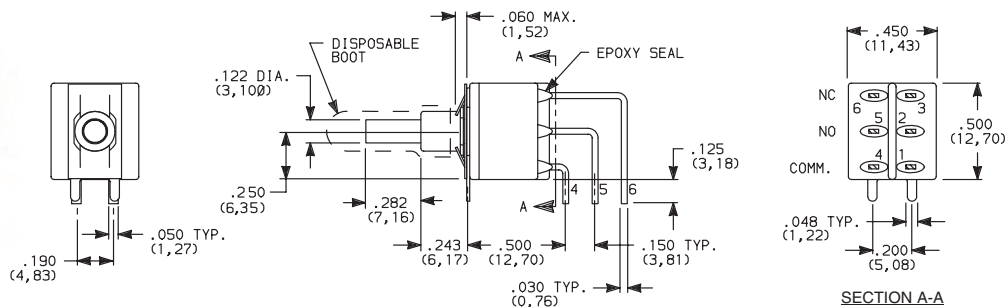

AV3 VERTICAL RIGHT ANGLE, SNAP-IN, PC THRU-HOLE,
.150" PITCH

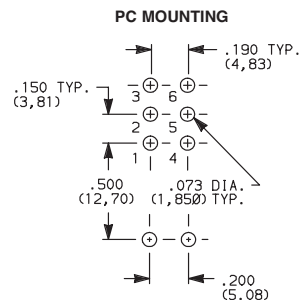
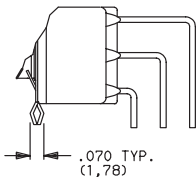
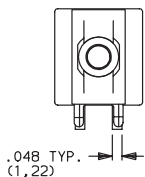

NOTE: Terminal bend radii and lead-in manufacturing option.



Dimensions are shown: Inches (mm)
Specifications and dimensions subject to change

E020 Series Sealed Snap-acting Momentary Pushbutton Switches



A

Pushbutton

TERMINATIONS

V3, V4 VERTICAL MOUNT, V-BRACKET

V31, V41 VERTICAL MOUNT, V-BRACKET, SNAP-IN

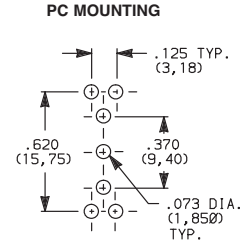
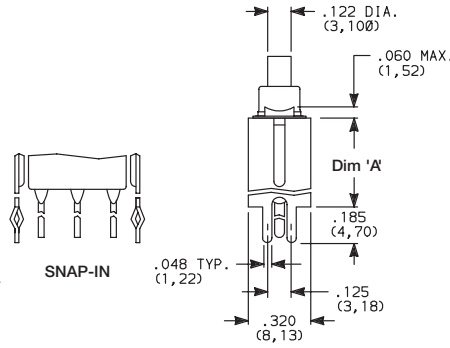
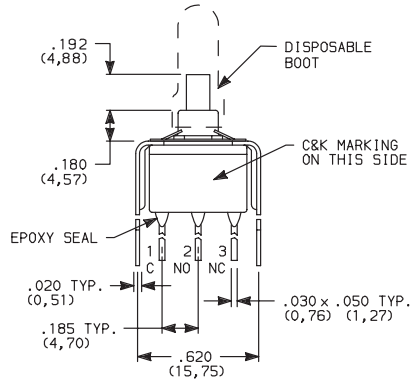

E121SD3_GE SPDT

| OPTION CODE | DIM 'A' |
|-------------|--------------|
| V3, V31 | .460 (11,68) |
| V4, V41 | .630 (16,00) |

V3, V4 VERTICAL MOUNT, V-BRACKET

V31, V41 VERTICAL MOUNT, V-BRACKET, SNAP-IN

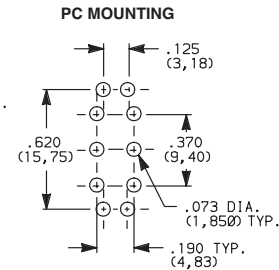
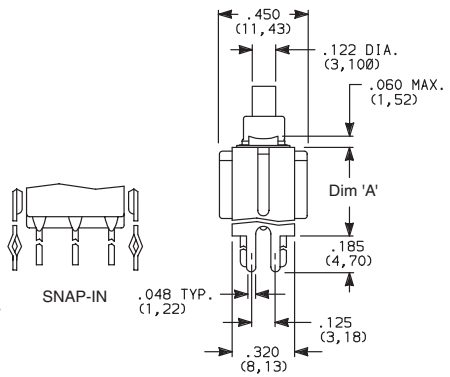
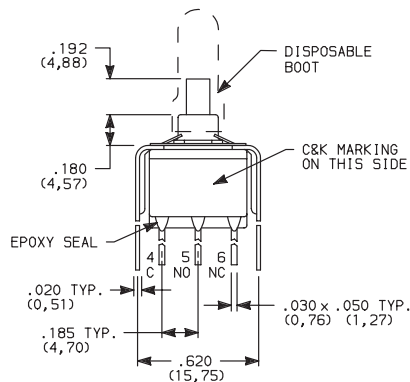

E221SD3_GE DPDT

| OPTION CODE | DIM 'A' |
|-------------|--------------|
| V3, V31 | .460 (11,68) |
| V4, V41 | .630 (16,00) |

V6, V8 VERTICAL MOUNT, V-BRACKET

V61, V81 VERTICAL MOUNT, V-BRACKET, SNAP-IN

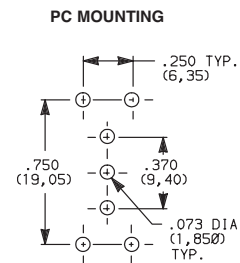
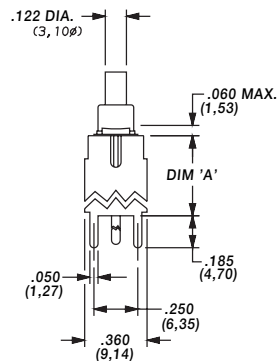
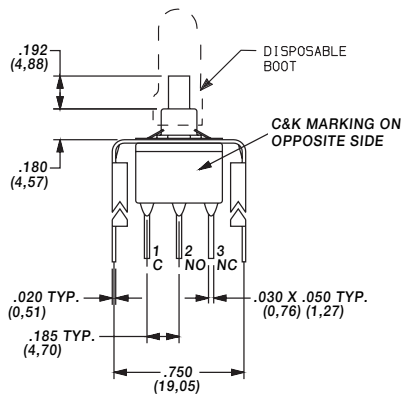

E121SD3_GE SPDT

| OPTION CODE | DIM 'A' |
|-------------|--------------|
| V6, V61 | .460 (11,68) |
| V8, V81 | .953 (24,21) |

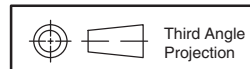

Dimensions are shown: Inches (mm)
Specifications and dimensions subject to change

www.ck-components.com



E020 Series Sealed Snap-acting Momentary Pushbutton Switches

Pushbutton

A

TERMINATIONS

V6, V8 VERTICAL MOUNT, V-BRACKET

V61, V81 VERTICAL MOUNT, V-BRACKET, SNAP-IN



E221SD3V6GE DPDT

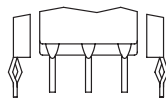
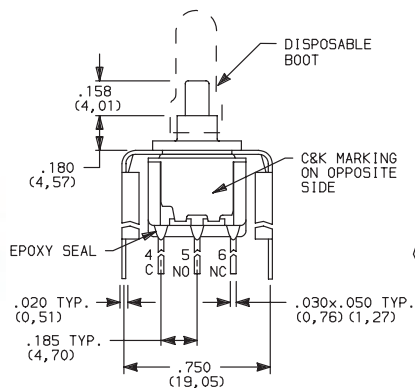

SNAP-IN

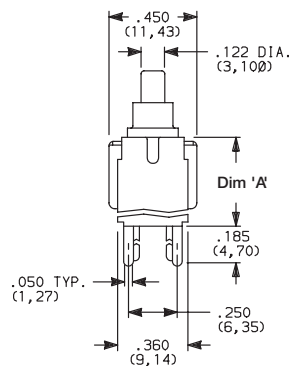

PC MOUNTING

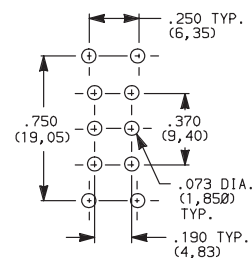

| OPTION CODE | DIM 'A' |
|----------------|--------------|
| V6, V61 | .460 (11,68) |
| V8, V81 | .953 (24,21) |

CONTACT MATERIAL

| OPTION CODE | CONTACT MATERIAL | TERMINAL PLATING | RATINGS | |
|-------------|---------------------------------|------------------------|--------------------------------|---|
| | | | | |
| B | GOLD ¹ | GOLD ¹ | LOW LEVEL/DRY CIRCUIT | EX25 MODELS ONLY: 0.4 VA MAX. @ 20 V AC OR DC MAX. |
| P | | MATTE-TIN ⁴ | | |
| G | GOLD OVER SILVER ^{2,3} | GOLD ³ | LOW LEVEL/DRY CIRCUIT OR POWER | EX21 MODELS ONLY: 0.4 VA MAX @ 20 V AC OR DC MAX. OR 1 AMP @ 120 V AC OR 28 V DC. |
| R | | MATTE-TIN ⁴ | | |

* Note: See Technical Data section of this catalog for RoHS compliant and compatible definitions and specifications.

- ¹ CONTACTS & TERMINALS: Copper alloy, with gold plate over nickel plate.
- ² N.O. AND N.C. CONTACTS: Coin silver, with gold plate over nickel plate.
- ³ COMMON CONTACTS & ALL TERMINALS: Copper alloy, with gold plate over nickel plate.
- ⁴ TERMINALS: Copper alloy, with matte-tin alloy over nickel plate.

NOTE: Any models supplied with P, R, B or G contact material are RoHS compliant.

E121, E221 models with all options when ordered with mandatory G, or R contact material.
 P or B contact material must be ordered with EX25 models.
 R or G contact material must be ordered with EX21 models.

SEAL

E EPOXY SEAL AND DISPOSABLE SPLASHPROOF BOOT

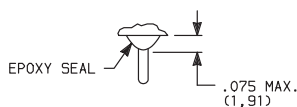

Disposable splashproof boot supplied standard. Remove and discard boot *only after* soldering and cleaning processes are complete.

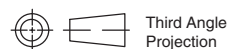
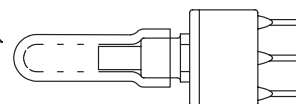

Third Angle Projection

Dimensions are shown: Inches (mm)
 Specifications and dimensions subject to change



E020 Series Sealed Snap-acting Momentary Pushbutton Switches



A
Pushbutton

AVAILABLE HARDWARE

Cap

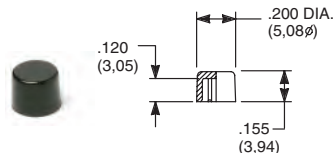

PART NO.

- 708901000** WHITE
- 708902000** BLACK
- 708903000** RED

Material: Nylon
Finish: Gloss

Cap

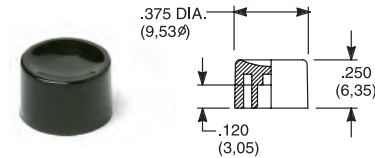

PART NO.

- 752701000** WHITE
- 752702000** BLACK
- 752703000** RED

Material: Nylon
Finish: Gloss

Cap

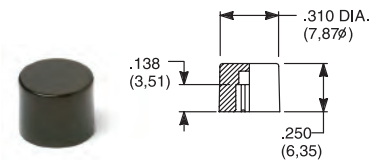

PART NO.

- 801801000** WHITE
- 801802000** BLACK
- 801803000** RED

Material: Nylon
Finish: Gloss

Cap, Snap-fitting plunger

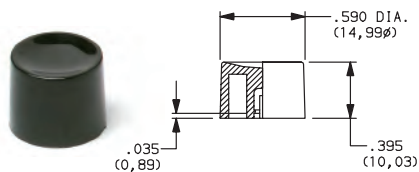

PART NO.

- 452D01000** WHITE
- 452D02000** BLACK
- 452D03000** RED

Material: Nylon
Finish: Gloss

Cap, Snap-fitting plunger

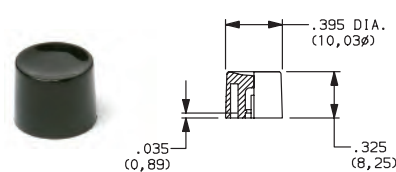

PART NO.

- 894101000** WHITE
- 894102000** BLACK
- 894103000** RED

Material: Nylon
Finish: Gloss

Cap

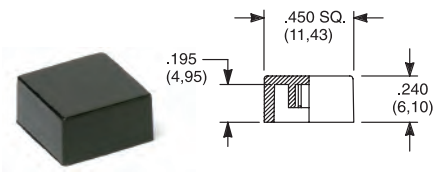

PART NO.

- 484601000** WHITE
- 484602000** BLACK
- 484603000** RED

Material: Nylon
Finish: Gloss

PART NO.

- 798201000** WHITE
- 798202263** BLACK
- 798203000** RED

Material: Nylon
Finish: Matte

NOTE: Other cap colors available, consult Customer Service Center.

Frames snap into panel opening and are independent from switch mounting. Accurate positioning of the PC mounted switch relative to the panel opening is necessary to provide proper clearance between actuator and frame. Available in two basic styles and four panel thicknesses .047-.125 in. Material: Nylon. Finish: Matte.

TYPICAL APPLICATION

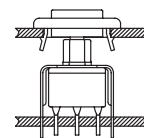

.047" (1,19) PANEL THK.

PART NO.
432502263

.062" (1,57) PANEL THK.

PART NO.
432602263

.090" (2,29) PANEL THK.

PART NO.
432702263

.125" (3,18) PANEL THK.

PART NO.
432802263 BLACK

PANEL MOUNTING

For part numbers
4325xxxxx, 4326xxxxx

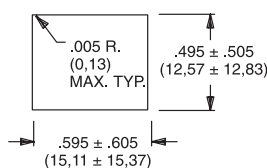

For part numbers
4327xxxxx, 4328xxxxx

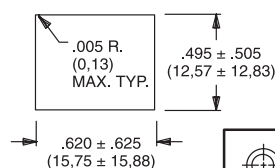

Dimensions are shown: Inches (mm)
Specifications and dimensions subject to change





E020 Series Sealed Snap-acting Momentary Pushbutton Switches

AVAILABLE HARDWARE

Pushbutton
A

PANEL INSERTS

Above frames (part nos. 432XXXXXX) are also available with insert which accepts LED for indicator light assembly. Order insert separately from frame. Blank insert panel (without hole for LED) also available. **LED not included.**

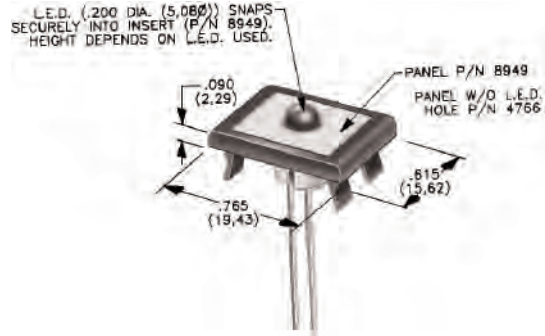

PANEL INSERT
WITH HOLE FOR LED

BLANK PANEL INSERT
WITHOUT HOLE FOR LED

PART NO.

894902000

PART NO.

476602000 BLACK

Special colors, custom markings available, consult Customer Service Center.

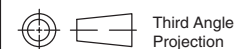

Dimensions are shown: Inches (mm)
Specifications and dimensions subject to change

8020 Series Snap-acting Momentary Pushbutton Switches

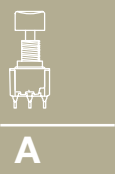

Pushbutton

Features/Benefits

- **Positive tactile feel**
- **Multi-positions available**
- **Wide variety of termination options**
- **Epoxy terminal seal compatible with bottom wash cleaning**
- **RoHS compliant models available**



Models Available

Typical Applications

- **Instrumentation**
- **Computer peripherals**
- **Telecommunications equipment**



Specifications

CONTACT RATING: B contact material (8X25 Models): 0.4 VA max. @ 20 V AC or DC maximum. G contact material (8X21, U8X1 Models): 1 AMP @ 120 V AC or 28 V DC or 0.4 VA max. @ 20 V AC or DC max. Note: Break-before-makecontacts. Multi-pole contacts do not make and break simultaneously. See page A-43 for additional ratings.

ELECTRICAL LIFE: 60,000 make-and-break cycles at full load.

CONTACT RESISTANCE: Below 50 mΩ typ. initial @ 2-4 V DC, 100 mA, for both silver and gold plated contacts.

INSULATION RESISTANCE: 10⁹Ω min.

DIELECTRIC STRENGTH: 1,000 Vrms min. @ sea level.

OPERATING TEMPERATURE: 8X2X MODELS: -30°C to 75°C.
U8X1 MODELS: -30°C to 65°C.

CAP INSTALLATION FORCE: 10 lbs. max. permissible.

SOLDERABILITY: Per MIL-STD-202F method 208D, or EIA RS-186E method 9 (1 hour steam aging).

NOTE: Any models supplied with B, P, R, or G contact material are RoHS compliant.

NOTE: Specifications and materials listed above are for switches with standard options. For information on specific and custom switches, consult Customer Service Center.

Materials

CASE: Glass filled nylon 6/6 or diallyl phthalate (DAP), flame retardant (UL 94V-0).

PLUNGER: Glass filled nylon or glass filled polyester (PBT) (UL 94V-0).

CAP & FRAME: Nylon, black, standard.

BUSHING: Brass or zinc, nickel plated.

HOUSING: Stainless steel.

SWITCH SUPPORT: Brass or steel, matte-tin plated.

N.O. & N.C. CONTACTS: 8X21, U8X1 MODELS: G contact material: Coin silver, with gold plate over nickel plate. See page A-43 for additional contact materials.

8X25 MODELS: B contact material: Copper alloy, with gold plate over nickel plate. See page A-43 for additional contact materials.

COMMON CONTACT & ALL TERMINALS: Copper alloy, with gold plate over nickel plate.

TERMINAL SEAL: Epoxy. Refer to soldering and cleaning Technical Data Chapter.

HARDWARE: Nut & Locking Ring: Brass, nickel plated;
Lockwasher: Steel, nickel plated.

Build-A-Switch

To order, simply select desired option from each category and place in the appropriate box. Available options are shown and described on pages A-30 thru A-45. For additional options not shown in catalog, consult Customer Service Center. All models have epoxy terminal seal and are compatible with all "bottom-wash" PCB cleaning methods.



Switch Function

- 8121** SPDT On-Mom. 1 Amp
- 8125** SPDT On-Mom. 0.4VA
- 8221** DPDT On-Mom. 1 Amp
- 8225** DPDT On-Mom. 0.4VA
- 8321** 3PDT On-Mom. 1 Amp
- 8325** 3PDT On-Mom. 0.4VA
- 8421** 4PDT On-Mom. 1 Amp
- 8425** 4PDT On-Mom. 0.4VA

Note: UL models available, see page A-30 and A-31.

Actuator or Plunger

- S** Plunger
- NONE** Snap-in
- J80** Snap-in
- J81** Snap-in w/frame
- J82** Snap-in w/frame for LED
- J83** Snap-in w/frame & flush cap
- J84** Snap-in w/frame for LED, flush cap
- J85** Snap-in w/frame & LED
- J95** PC w/V-bracket & LED
- L** Plunger
- M** Snap-fitting plunger

Bushing

- D9** .280" high, keyway
- H** .250" high, flat
- NONE** No bushing choice required
- D** .280" high, keyway
- D2** .288" high, flat
- D3** .180" high
- D8** .288" high, flat
- H9** .250" high, flat, hi torque
- Y** .350" high, keyway
- Y3** 6.35mm high, keyway, hi torque
- Y4** .378" high, flat, hi torque
- Y9** .350" high, keyway

Contact Material

- B** Gold
- P** Gold, matte-tin
- G** Gold over silver
- R** Gold over silver, matte-tin

Seal

- E** Epoxy
- I** Epoxy potted base

Cap Color

- 2** Black
- NONE** Models without caps
- 1** White
- 3** Red
- 4** Orange
- 5** Yellow
- 6** Green
- 7** Blue
- 9** Gray

Frame Color

- 2** Black
- NONE** Models without frame
- 1** White
- 3** Red
- 5** Yellow
- 6** Green
- 9** Gray

LED Color

- 3** Red
- NONE** Models without LED
- 5** Yellow
- 6** Green

Terminations

- A** Right angle, PC thru-hole
- AV2** Vertical right angle, PC thru-hole
- C** PC Thru-hole
- Z** Solder lug
- A2** Right angle, PC thru-hole
- A3** Right angle, snap-in, PC thru-hole
- A4** Right angle, PC thru-hole, reversed terminals
- A6** Right angle, PC thru-hole
- AV1** Vertical right angle, PC thru-hole
- AV3** Vertical right angle, snap-in, PC thru-hole
- R** Right angle with PCB
- R2** Right angle with PCB, reversed terminals
- V2** .555" high, V-bracket
- V3** .460" high, V-bracket
- V4** .630" high, V-bracket
- V6** .460" high, V-bracket
- V7** .630" high, V-bracket
- V8** .953" high, V-bracket
- V9** 1.150" high, V-bracket
- V31** .460" high, snap-in V-bracket
- V61** .460" high, snap-in V-bracket
- W** .750" long, wire wrap
- W1** .964" long, wire wrap
- W3** .425" long, wire wrap
- W4** 1.062" long, wire wrap
- Z3** Quick connect



Dimensions are shown: Inches (mm)
Specifications and dimensions subject to change



8020 Series Snap-acting Momentary Pushbutton Switches

SWITCH FUNCTION

Pushbutton
A

| NO. POLES | MODEL NO. | UL/CSA* MODEL NO. | SWITCH FUNCTION | | CONNECTED TERMINALS | | SCHEMATIC |
|--|-----------|-------------------|-----------------|--------|---------------------|-------------|-----------|
| | | | POS. 1 | POS. 2 | POS. 1 | POS. 2 | |
| SP | 8121 | U811 | ON | MOM. | 1-3 | 1-2 | |
| | 8125 | | ON | MOM. | | | |
| <p>SPDT</p> <p>Part number shown: 8121SHZGE</p> <p>Terminal Nos. For Reference Only</p> | | | | | | | |
| DP | 8221 | U821 | ON | MOM. | 1-3,4-6 | 1-2,4-5 | |
| | 8225 | | ON | MOM. | | | |
| <p>DPDT</p> <p>Part number shown: 8221SHZGE</p> <p>Terminal Nos. For Reference Only</p> | | | | | | | |
| 3P | 8321 | U831 | ON | MOM. | 1-3,4-6,7-9 | 1-2,4-5,7-8 | |
| | 8325 | | ON | MOM. | | | |
| <p>3PDT</p> <p>Part number shown: 8321SHZGE</p> <p>Terminal Nos. For Reference Only</p> | | | | | | | |

MOM. = Momentary

*U811 thru U841 model numbers with all options (except R, R2 terminations) when ordered with G or R contact material.

8X25 models must be ordered with B or P contact material.

8X21 and U8X1 models must be ordered with G or R contact material.



Dimensions are shown: Inches (mm)
Specifications and dimensions subject to change

8020 Series Snap-acting Momentary Pushbutton Switches



A

Pushbutton

SWITCH FUNCTION

| NO. POLES | MODEL NO. | UL/CSA* MODEL NO. | SWITCH FUNCTION | | CONNECTED TERMINALS | | SCHEMATIC |
|-----------|-----------|-------------------|-----------------|--------|---------------------|-------------------|-----------|
| | | | POS. 1 | POS. 2 | POS. 1 | POS. 2 | |
| 4P | 8421 | U841 | ON | MOM. | 1-3,4-6,7-9,10-12 | 1-2,4-5,7-8,10-11 | |
| | 8425 | | ON | MOM. | | | |

4PDT

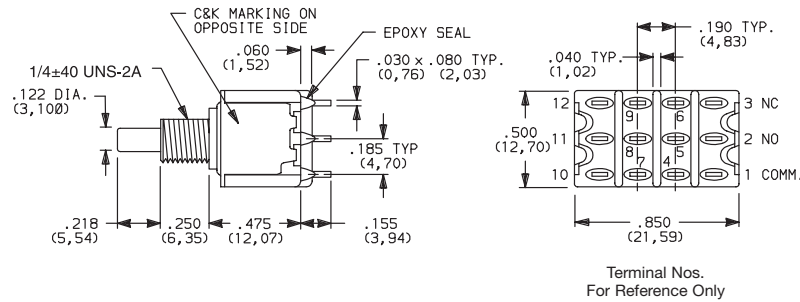

Part number shown: 8421SHZGE

Terminal Nos. For Reference Only

MOM. = Momentary

* U811 thru U841 model numbers with all options (except R, R2 terminations) when ordered with G or R contact material.

8X25 models must be ordered with B or P contact material.

8X21 and U8X1 models must be ordered with G or R contact material.

ACTUATOR—SNAP-IN FRONT MOUNT

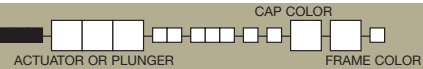

| OPTION CODE | CAP AND FRAME COLOR |
|-------------|-----------------------------|
| 2 | BLACK |
| NONE | No Frame Color (J80 option) |
| 1 | WHITE |
| 3 | RED |
| 4 | ORANGE |
| 5 | YELLOW |
| 6 | GREEN |
| 7 | BLUE |
| 9 | GRAY |

Other colors available, consult Customer Service Center. Cap and Frame Finish: matte.

NOTE: Caps and frames available separately, see pages A-44 and A-45.

J80 SNAP-IN

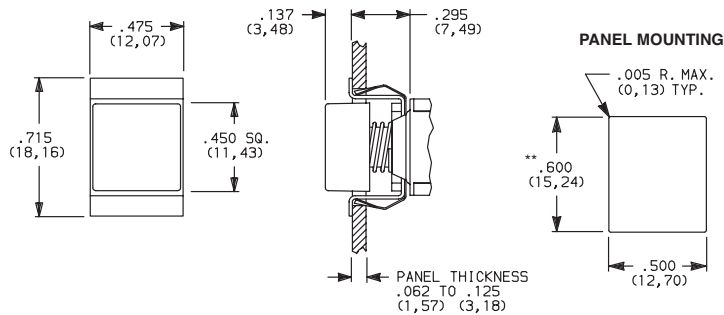

NOTE: No frame color choice required.

** Increase this dim. to .620/.625 (15,75/15,88) for .091/.125 (2,31/3,18) thk. panels.

J81 SNAP-IN WITH FRAME

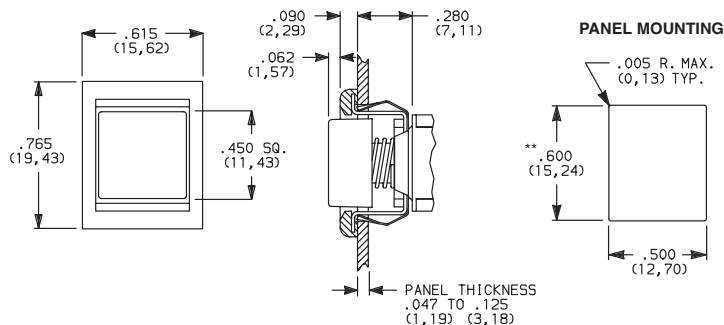

NOTE: Available with C, W-W4, Z or Z3 terminations and SPDT and DPDT models only.

** Increase this dim. to .620/.625 (15,75/15,88) for .091/.125 (2,31/3,18) thk. panels.

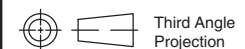

Third Angle Projection



Dimensions are shown: Inches (mm)
Specifications and dimensions subject to change



8020 Series Snap-acting Momentary Pushbutton Switches

Pushbutton
A

ACTUATOR—SNAP-IN FRONT MOUNT



J83 SNAP-IN WITH FRAME AND FLUSH CAP

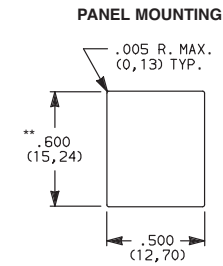
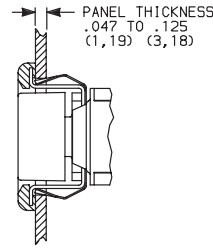
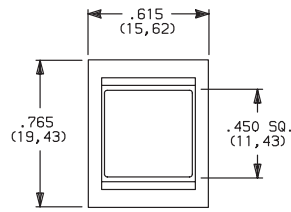

J82 SNAP-IN WITH FRAME FOR LED

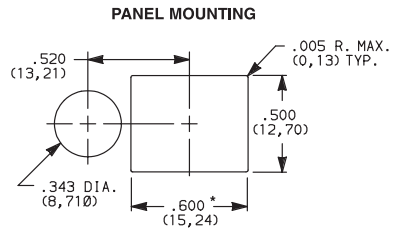
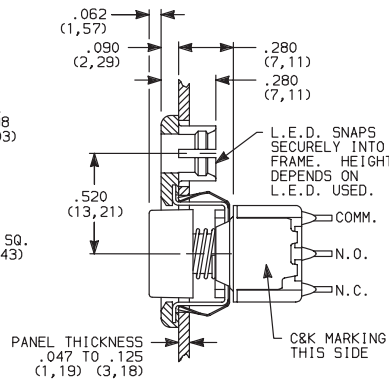
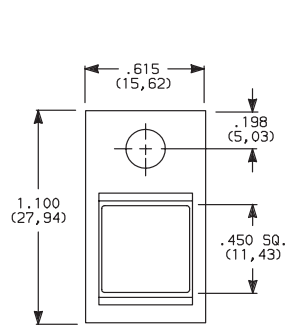

* Increase this dim. to .620/.625 (15,75/15,88) for .091/.125 (2,31/3,18) thk. panels.

LED not included.
For LED information, see page A-45.

J84 SNAP-IN WITH FRAME FOR LED, FLUSH CAP

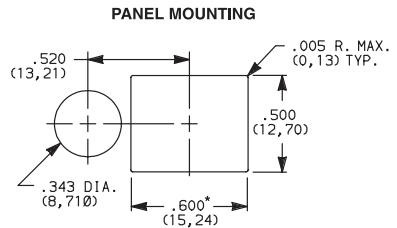
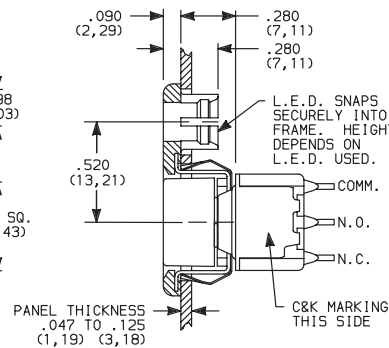
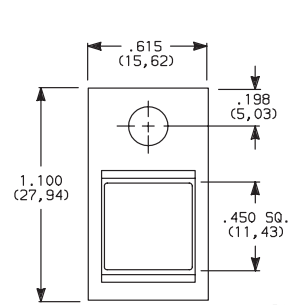

* Increase this dim. to .620/.625 (15,75/15,88) for .091/.125 (2,31/3,18) thk. panels.

LED not included.
For LED information, see page A-45.

| OPTION CODE | CAP AND FRAME COLOR |
|-------------|---------------------|
| 2 | BLACK |
| 1 | WHITE |
| 3 | RED |
| 4 | ORANGE |
| 5 | YELLOW |
| 6 | GREEN |
| 7 | BLUE |
| 9 | GRAY |

Other colors available, consult Customer Service Center.
Cap and Frame Finish: matte.

Available with C, W-W4, Z or Z3 terminations and SPDT and DPDT models only.

NOTE: Caps and frames available separately, see pages A-44 and A-45.



Third Angle Projection



Dimensions are shown: Inches (mm)
Specifications and dimensions subject to change

8020 Series Snap-acting Momentary Pushbutton Switches



A

Pushbutton

ACTUATOR—SNAP-IN FRONT MOUNT

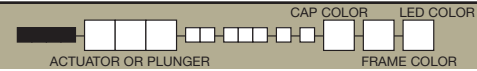

J85 SNAP-IN WITH FRAME AND LED

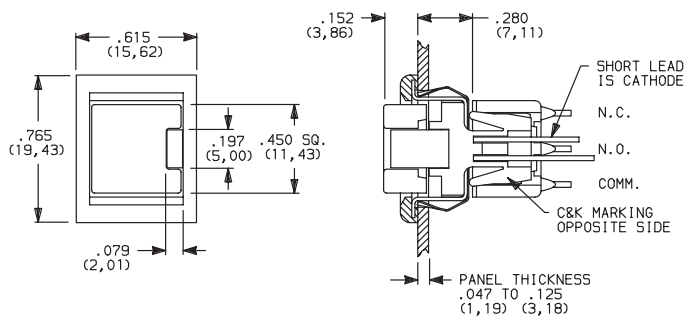

PANEL MOUNTING

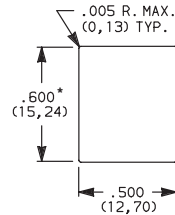

* Increase this dim. to .620/.625 (15,75/15,88) for .091/.125 (2,31/3,18) thk. panels.



8121J85ZGE223 SPST

Available with C, W-W4, Z or Z3 terminations and SPDT models only. For LED information see page A-45.

NOTE: Caps & frames available separately, see pages A-44 and A-45.

| OPTION CODE | CAP AND FRAME COLOR |
|-------------|---------------------|
| 2 | BLACK |
| 1 | WHITE |
| 3 | RED |
| 4 | ORANGE |
| 5 | YELLOW |
| 6 | GREEN |
| 7 | BLUE |
| 9 | GRAY |

| OPTION CODE | LED COLOR |
|-------------|-----------|
| 3 | RED |
| 5 | YELLOW |
| 6 | GREEN |

For LED information see page A-45.

ACTUATOR—PC MOUNT

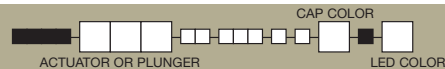

J95 PC WITH V-BRACKET AND LED

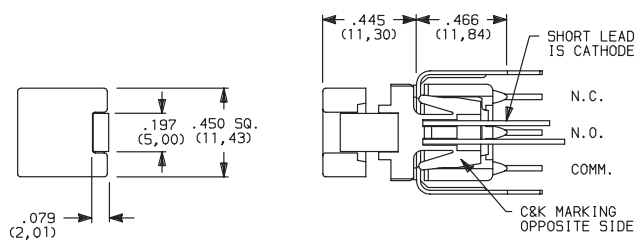

PC MOUNTING

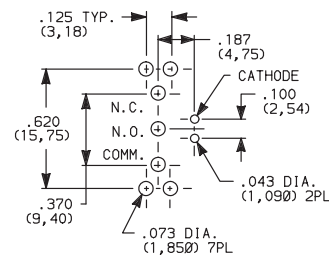

8121J95V3GE23 SPST

| OPTION CODE | CAP AND FRAME COLOR |
|-------------|---------------------|
| 2 | BLACK |
| 1 | WHITE |
| 3 | RED |
| 4 | ORANGE |
| 5 | YELLOW |
| 6 | GREEN |
| 7 | BLUE |
| 9 | GRAY |

| OPTION CODE | LED COLOR |
|-------------|-----------|
| 3 | RED |
| 5 | YELLOW |
| 6 | GREEN |

For LED information see page A-45.

NOTE: Caps available separately, see page A-44. Available with V3 terminations and SPDT models only.

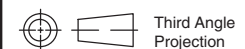

Third Angle Projection



Dimensions are shown: Inches (mm)
Specifications and dimensions subject to change

www.ck-components.com



8020 Series Snap-acting Momentary Pushbutton Switches

Pushbutton

A

PLUNGER



S PLUNGER

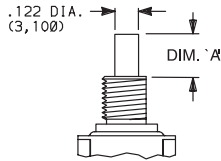

NONE NO PLUNGER CHOICE REQUIRED (JXX ACTUATORS)

L PLUNGER

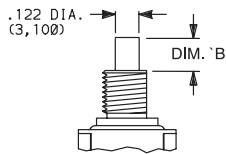

M SNAP-FITTING PLUNGER

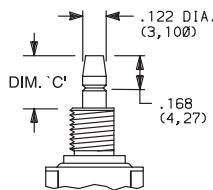

| AVAILABLE BUSHINGS | DIM. 'A' FOR C, W-W4, Z & Z3 TERMINATIONS | DIM. 'A' FOR A, A2, A3, A4, A6, AV-A3, R & R2 TERMINATIONS | DIM. 'A' FOR V3-V61 TERMINATIONS |
|--------------------|---|--|----------------------------------|
| D, D9 | .244 (6,20) | .228 (5,79) | .224 (5,69) |
| H, H9 | .218 (5,54) | .202 (5,13) | .198 (5,03) |
| Y, Y9 | .203 (5,16) | .187 (4,75) | .183 (4,65) |
| Y3 | (5,54) | (5,13) | (5,03) |
| Y4 | .185 (4,70) | .169 (4,29) | .165 (4,19) |
| D2, D8 | N/A | .232 (5,89) | .228 (5,79) |
| D3 | N/A | .162 (4,11) | .158 (4,01) |

| AVAILABLE BUSHINGS | DIM. 'B' FOR C, W-W4, Z & Z3 TERMINATIONS | DIM. 'B' FOR A, A2, A3, A4, A6, AV-A3, R & R2 TERMINATIONS | DIM. 'B' FOR V3-V61 TERMINATIONS |
|--------------------|---|--|----------------------------------|
| Y, Y9 | .178 (4,52) | .162 (4,11) | .158 (4,01) |
| Y4 | .090 (2,29) | .074 (1,88) | .070 (1,78) |

| AVAILABLE BUSHINGS | DIM. 'C' FOR C, W-W4, Z & Z3 TERMINATIONS | DIM. 'C' FOR A, A2, A3, A4, A6, AV-A3, R & R2 TERMINATIONS | DIM. 'C' FOR V3-V61 TERMINATIONS |
|--------------------|---|--|----------------------------------|
| D, D9 | .297 (7,54) | .281 (7,14) | .277 (7,04) |
| H, H9 | .267 (6,78) | .251 (6,38) | .247 (6,27) |
| Y, Y9 | .259 (6,58) | .243 (6,17) | .239 (6,07) |
| Y3 | (6,78) | (6,37) | (6,27) |
| Y4 | .259 (6,58) | .243 (6,17) | .239 (6,07) |
| D2, D8 | N/A | .273 (6,93) | .269 (6,83) |
| D3 | N/A | .361 (9,17) | .357 (9,07) |

N/A = NOT AVAILABLE

NOTE: When selecting plunger option, bushing selection must also be made, see next page. No plunger option is required when any JXX actuator option is selected. Additional plunger lengths are available on SPDT and DPDT models, consult Customer Service Center. Not all plunger lengths sufficient for use with caps, see page A-44.

BUSHING

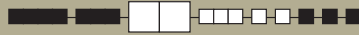

NONE NO BUSHING CHOICE REQUIRED (JXX ACTUATORS)

D .280" HIGH THREADED, KEYWAY
D9 .280" HIGH UNTHREADED, KEYWAY

H .250" HIGH THREADED, FLAT
H9 .250" HIGH UNTHREADED, FLAT

Y .350" HIGH THREADED, KEYWAY
Y9 .350" HIGH UNTHREADED, KEYWAY

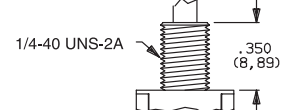
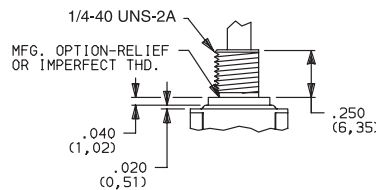
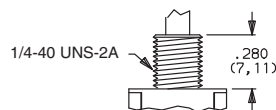
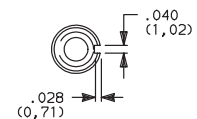
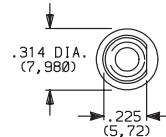
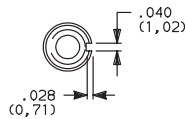

D9 bushing standard with A-A6, R, R2 AV-AV3 terminations.

H bushing standard with C, W-W4, Z or Z3 terminations. H, H9 bushings not available on single pole models with A3-A6, R, R2 terminations.

Will withstand 12 in./lbs. of torque with no distortion.

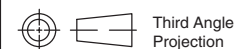

Dimensions are shown: Inches (mm)
 Specifications and dimensions subject to change

8020 Series Snap-acting Momentary Pushbutton Switches



A Pushbutton

BUSHING

Y3 6.35mm THREADED, KEYWAY

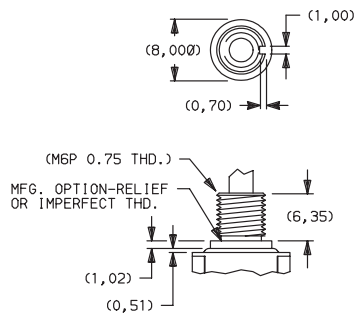

Y4 .378" HIGH THREADED, FLAT

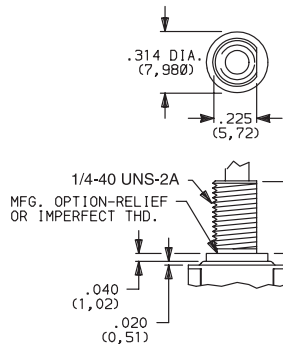

D2 .288" HIGH THREADED, FLAT
D8 .288" HIGH UNTHREADED, FLAT

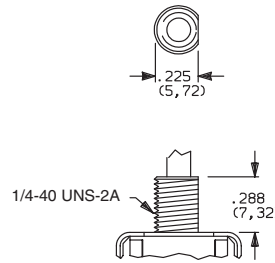

D3 .180" HIGH UNTHREADED

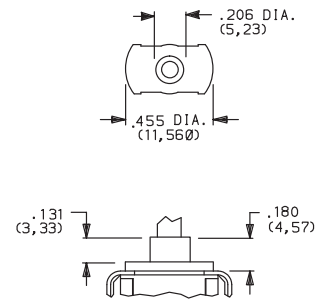

Y3 & Y4 bushings not available on single pole models with A3-A6, R, R2 terminations. Will withstand 12 in./lbs. of torque with no distortion.

D2, D8 bushings not available with C, W-W4, Z, Z3 terminations.

D3 bushing available with A, A2, A3, AV, AV2, AV3 and V2-V61 terminations only.

NOTE: No bushing option choice required when JXX actuator option is selected. When selecting bushing option, plunger selection must also be made, see previous page. Plunger lengths vary with bushing and termination options selected.

PANEL MOUNTING

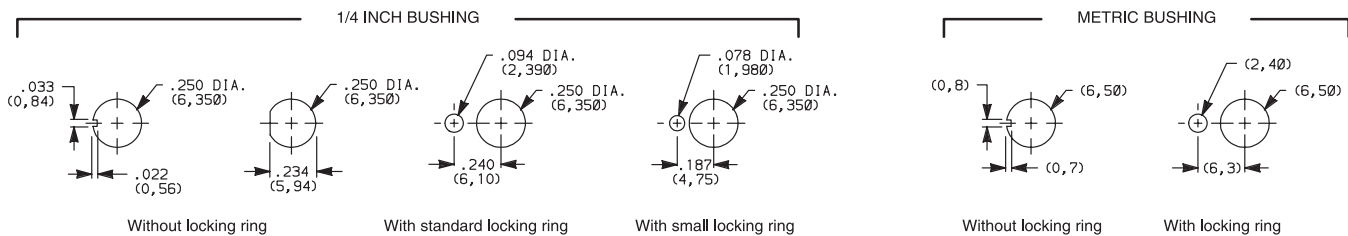

NOTE: Two mounting nuts, locking ring and lockwasher supplied standard with threaded bushings. Optional mounting nut and locking ring styles available, see section "Technical Data and Additional Hardware".

TERMINATIONS

Z SOLDER LUG

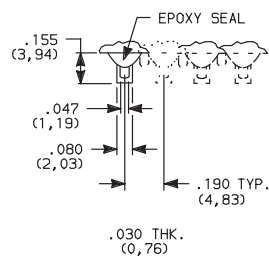

Not available with J95 actuator, P or R contact material.

SPDT thru 4PDT

C PC THRU-HOLE

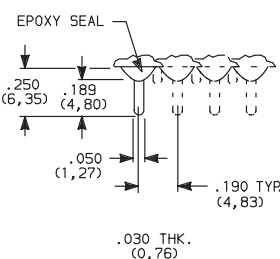

PC MOUNTING

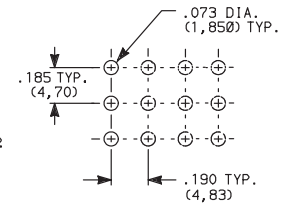

Not available with J95 actuator option.

SPDT thru 4PDT

Z3 QUICK CONNECT

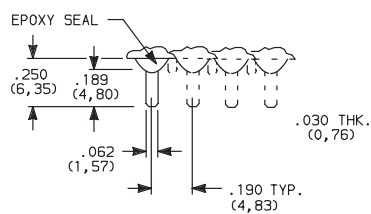

Not available with J95 actuator, P or R contact material. Mating quick connector available, order part number 530100000, page A-44.

SPDT thru 4PDT

W W1, W3, W4 WIRE WRAP

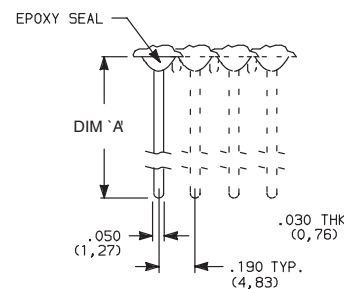

| OPTION CODE | DIM 'A' |
|-------------|---------------|
| W | .750 (19,05) |
| W1 | .964 (24,49) |
| W3 | .425 (10,80) |
| W4 | 1.062 (26,97) |

Not available with J95 actuator option.

SPDT thru 4PDT

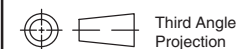

Dimensions are shown: Inches (mm)
Specifications and dimensions subject to change



8020 Series Snap-acting Momentary Pushbutton Switches

TERMINATIONS



A

Pushbutton

A RIGHT ANGLE, PC THRU-HOLE



8121SD9AGE
SPDT

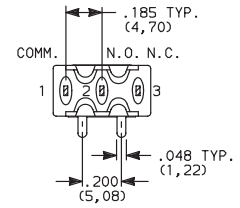
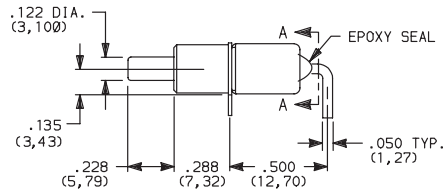
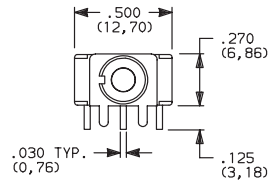

SECTION A-A

Terminal Nos.
For Reference Only.

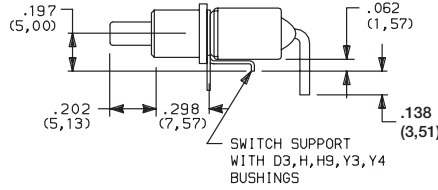

Part Number 8121SH9AGE

A3 RIGHT ANGLE, SNAP-IN, PC THRU-HOLE

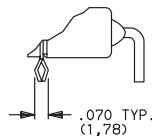
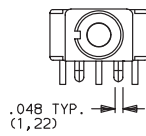

PC MOUNTING

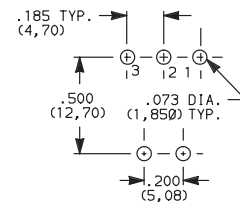

Not available with JXX actuators and I seal.
Terminal bend radii and lead-in manufacturing option.

A RIGHT ANGLE, PC THRU-HOLE



8221SD9AGE
DPDT

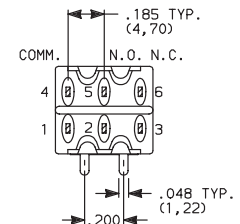
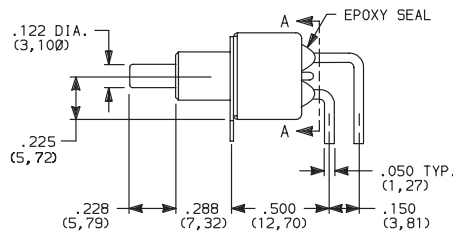
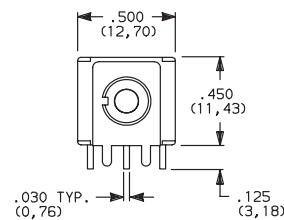

SECTION A-A

A3 RIGHT ANGLE, SNAP-IN, PC THRU-HOLE

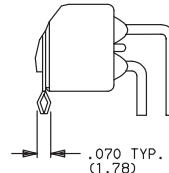
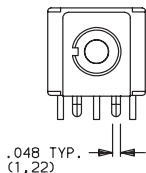

PC MOUNTING

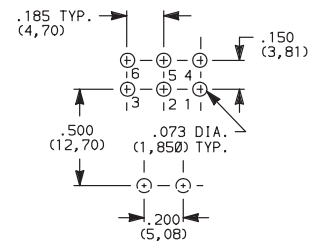

Not available with JXX actuators and I seal option.
Terminal bend radii and lead-in manufacturing option.



Dimensions are shown: Inches (mm)
Specifications and dimensions subject to change

8020 Series Snap-acting Momentary Pushbutton Switches



A

Pushbutton

TERMINATIONS

A RIGHT ANGLE, PC THRU-HOLE

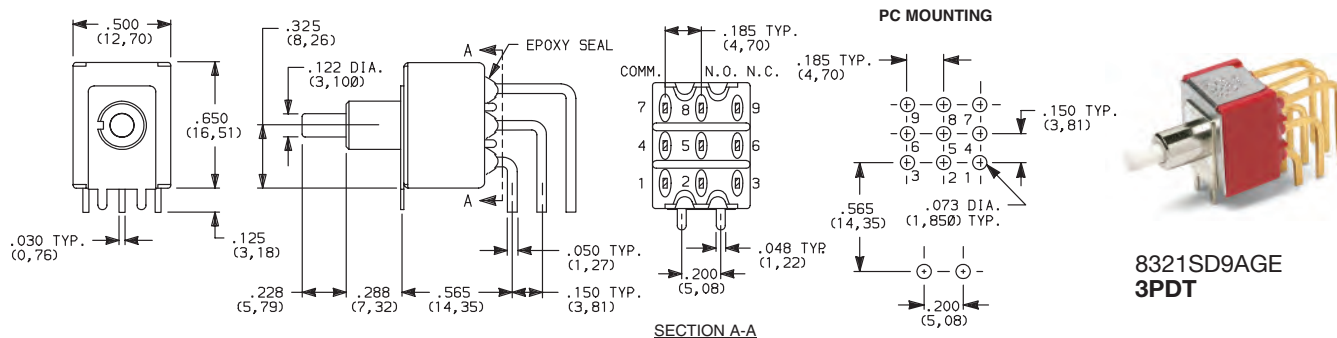

Not available with JXX actuators and I seal option.
Terminal bend radii and lead-in manufacturing option.

A2 RIGHT ANGLE, PC THRU-HOLE

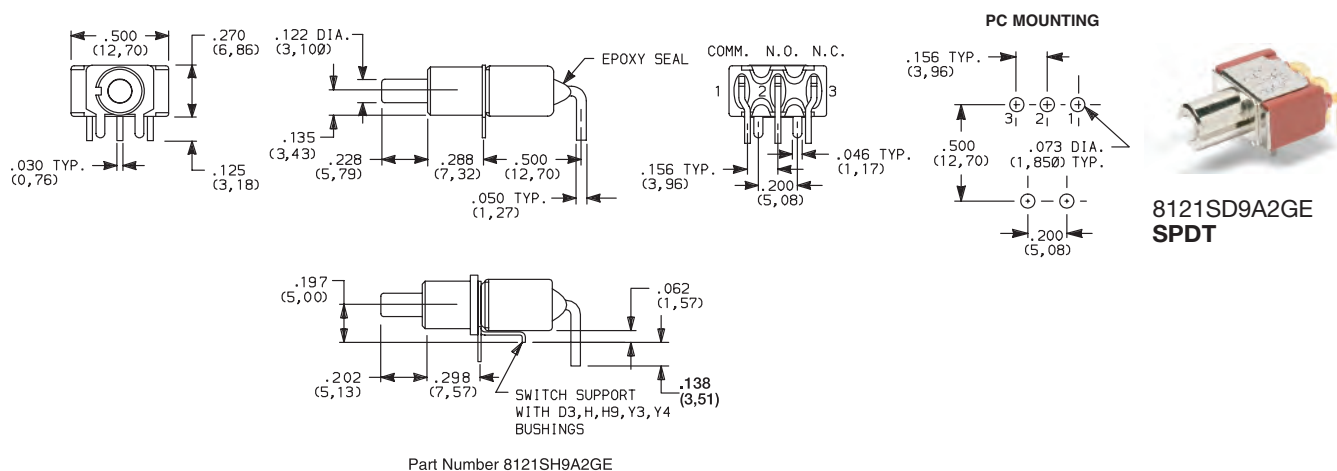

Not available with JXX actuators, I seal option.
Terminal bend radii and lead-in manufacturing option.

A4 RIGHT ANGLE, PC THRU-HOLE, REVERSED TERMINALS

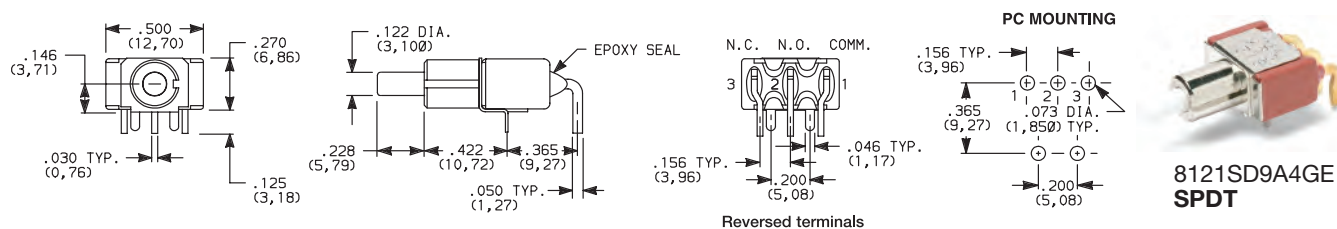

Not available with JXX actuators, D3, H, H9, Y3, Y4 bushings and I seal.
Terminal bend radii and lead-in manufacturing option.

The A4 and R2 termination options are functionally identical and fit the same PC mounting pattern. The switches, however, are shifted relative to the mounting holes. The PC pattern must clear the switch support legs. Unlike the R2, the A4 option is available with UL/CSA.



Third Angle Projection



Dimensions are shown: Inches (mm)
Specifications and dimensions subject to change



8020 Series Snap-acting Momentary Pushbutton Switches

TERMINATIONS



A

Pushbutton

A6 RIGHT ANGLE, PC THRU-HOLE



8121SD9A6GE
SPDT

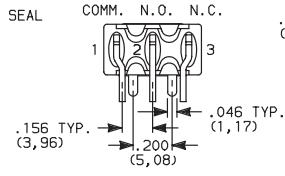
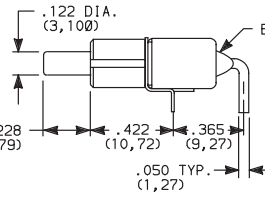
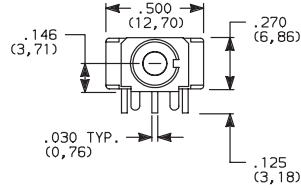

PC MOUNTING

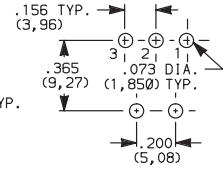

Not available with JXX actuators, D3, H, H9, Y3, Y4 bushings and I seal. Terminal bend radii and lead-in manufacturing option.

The A6 and R termination options are functionally identical and fit the same PC mounting pattern. The switches, however, are shifted relative to the mounting holes. The PC pattern must clear the switch support legs. Unlike the R, the A6 option is available with UL/CSA.

R RIGHT ANGLE WITH PCB



8121SD9RGE
SPDT

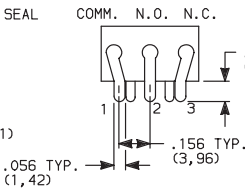
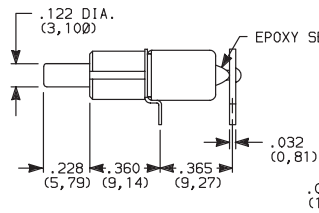
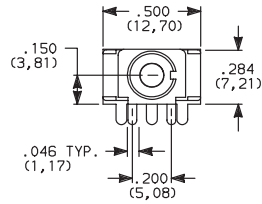

PC MOUNTING

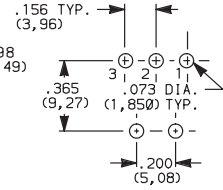

Not available with JXX actuators, D3, H, H9, Y3, Y4 bushings, I seal option. R termination not UL/CSA approved.

R2 RIGHT ANGLE WITH PCB, REVERSED TERMINALS



8121SD9R2GE
SPDT

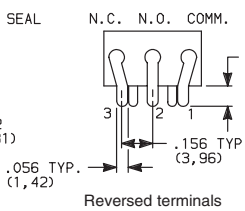
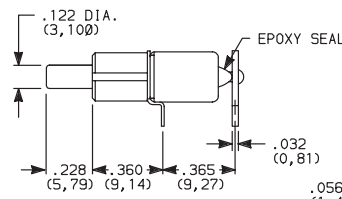
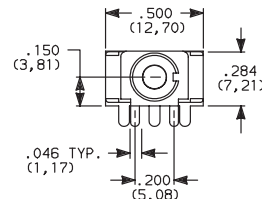

PC MOUNTING

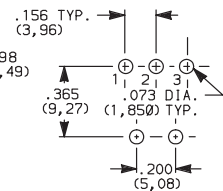

Not available with JXX actuators, D3, H, H9, Y3, Y4 bushings, I seal option. R2 termination not UL/CSA approved.



Dimensions are shown: Inches (mm)
Specifications and dimensions subject to change

8020 Series Snap-acting Momentary Pushbutton Switches



A

Pushbutton

TERMINATIONS

AV2 VERTICAL RIGHT ANGLE, PC THRU-HOLE, .150" PITCH

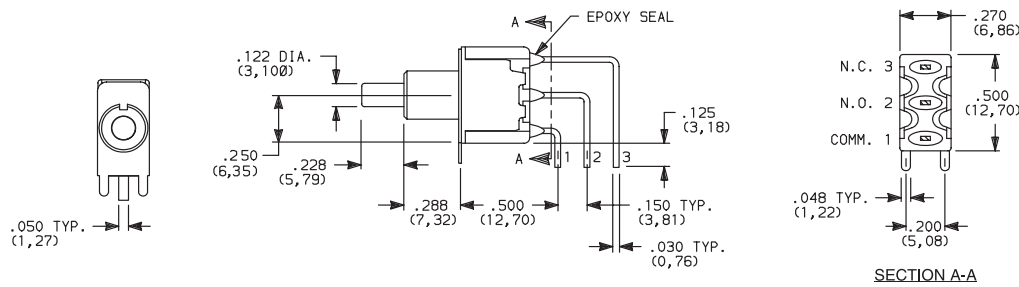

8121SD9AV2GE SPDT

AV3 VERTICAL RIGHT ANGLE, SNAP-IN, PC THRU-HOLE, .150" PITCH

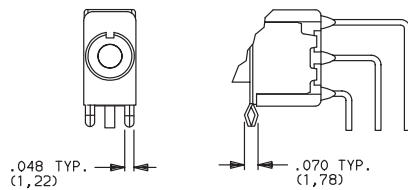

AV1 VERTICAL RIGHT ANGLE, EXTENDED, PC THRU-HOLE, .150" PITCH

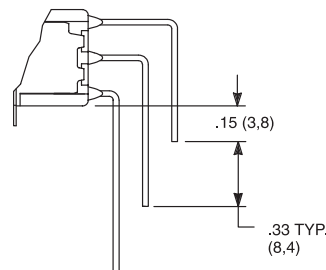

PC MOUNTING

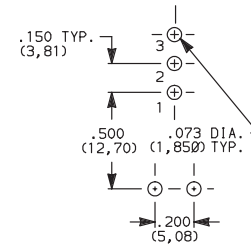

Not available with JXX actuators and I seal.
Terminal bend radii and lead-in manufacturing option.

AV2 VERTICAL RIGHT ANGLE, PC THRU-HOLE, .150" PITCH

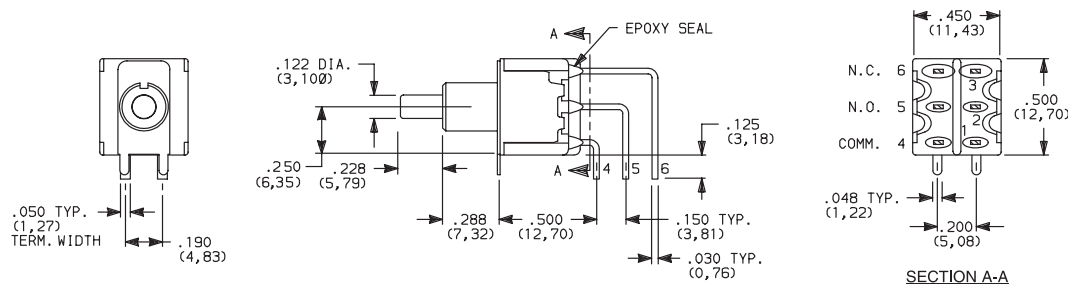

8221SD9AV2GE DPDT

AV3 VERTICAL RIGHT ANGLE, SNAP-IN, PC THRU-HOLE, .150" PITCH

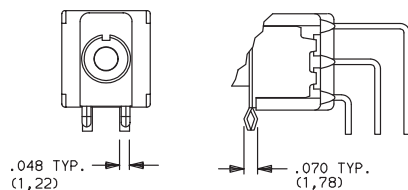

AV1 VERTICAL RIGHT ANGLE, EXTENDED, PC THRU-HOLE, .150" PITCH

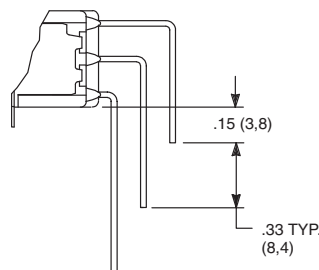

PC MOUNTING

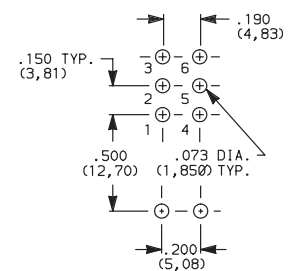

Not available with JXX actuators and I seal.
Terminal bend radii and lead-in manufacturing option.



Third Angle Projection



Dimensions are shown: Inches (mm)
Specifications and dimensions subject to change

www.ck-components.com



8020 Series Snap-acting Momentary Pushbutton Switches

TERMINATIONS



Pushbutton
A

AV2 VERTICAL RIGHT ANGLE, PC THRU-HOLE, 150° PITCH



8321SD9AV2GE
3PDT

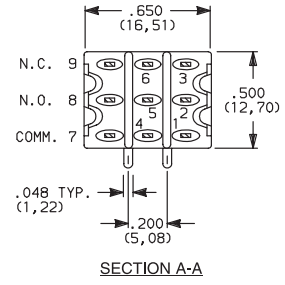
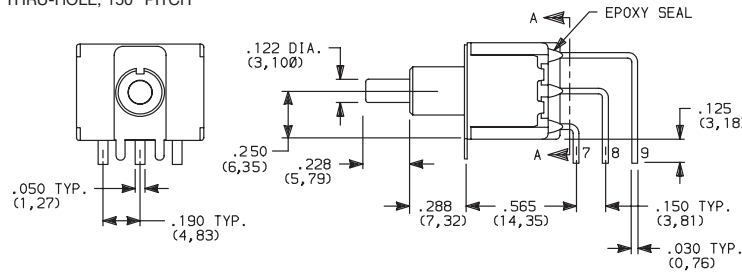

SECTION A-A

AV3 VERTICAL RIGHT ANGLE, SNAP-IN, PC THRU-HOLE, .150° PITCH

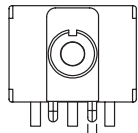

.048 TYP. (1,22)

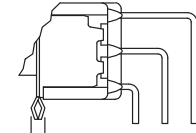

AV1 VERTICAL RIGHT ANGLE, EXTENDED, PC THRU-HOLE, .150° PITCH

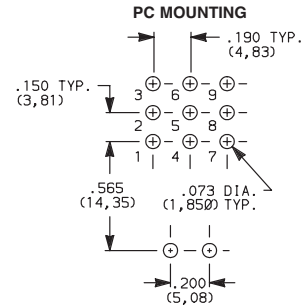
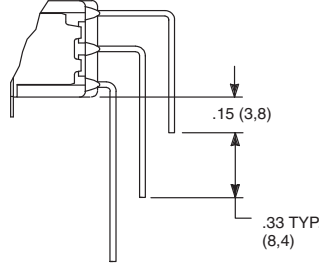

PC MOUNTING

Not available with JXX actuators and I seal.
Terminal bend radii and lead-in manufacturing option.

AV2 VERTICAL RIGHT ANGLE, PC THRU-HOLE, 150° PITCH



8421SD9AV2GE
4PDT

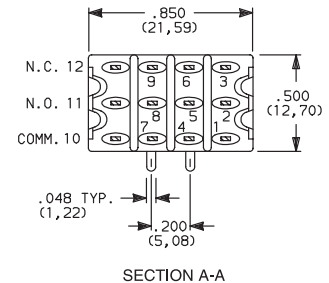
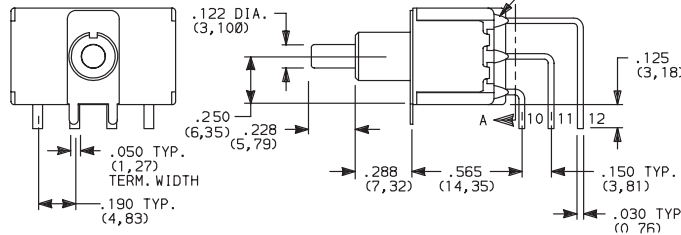

SECTION A-A

AV3 VERTICAL RIGHT ANGLE, SNAP-IN, PC THRU-HOLE, .150° PITCH

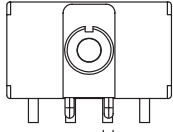

.048 TYP. (1,22)

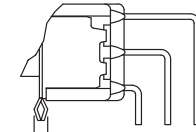

AV1 VERTICAL RIGHT ANGLE, EXTENDED, PC THRU-HOLE, .150° PITCH

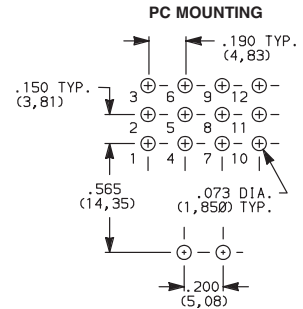
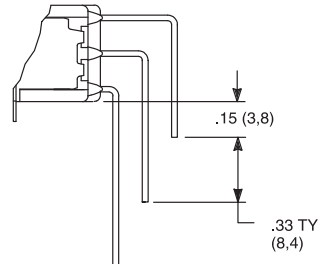

PC MOUNTING

Not available with JXX actuators and I seal.
Terminal bend radii and lead-in manufacturing option.

V2, V6, V7, V8 VERTICAL MOUNT, V-BRACKET

V61 VERTICAL MOUNT, V-BRACKET, SNAP-IN



8121SD3_GE
SPDT

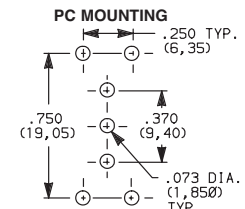
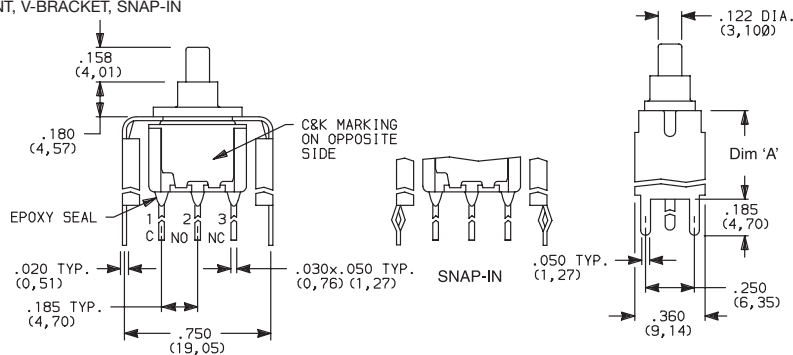

| OPTION CODE | DIM 'A' |
|-------------|--------------|
| V2 | .555 (14,10) |
| V6, V61 | .460 (11,68) |
| V7 | .630 (16,00) |
| V8 | .953 (24,21) |

Not available with JXX actuators and I seal.



Dimensions are shown: Inches (mm)
Specifications and dimensions subject to change

8020 Series Snap-acting Momentary Pushbutton Switches



A

Pushbutton

TERMINATIONS

V2, V6, V7, V8 VERTICAL MOUNT, V-BRACKET

V61 VERTICAL MOUNT, V-BRACKET, SNAP-IN

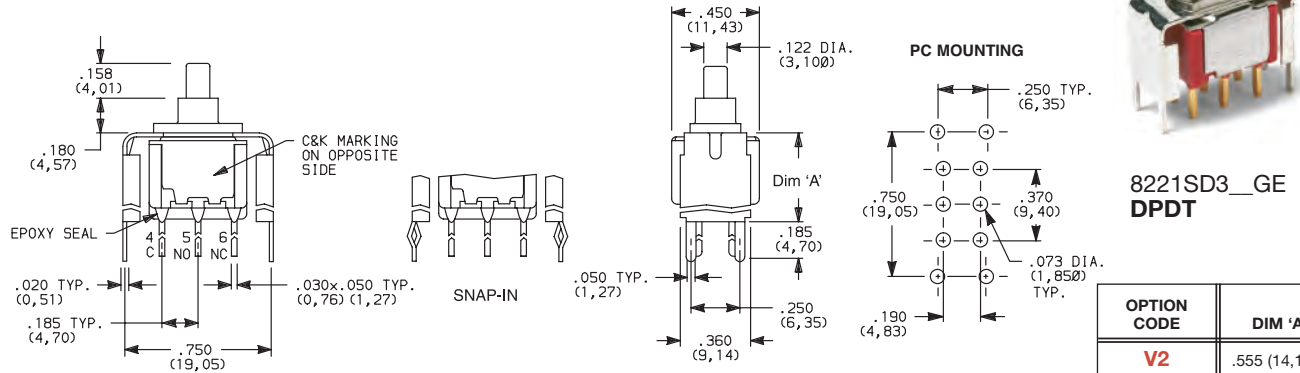

Not available with JXX actuators and I seal.

V2, V7, V8 VERTICAL MOUNT, V-BRACKET

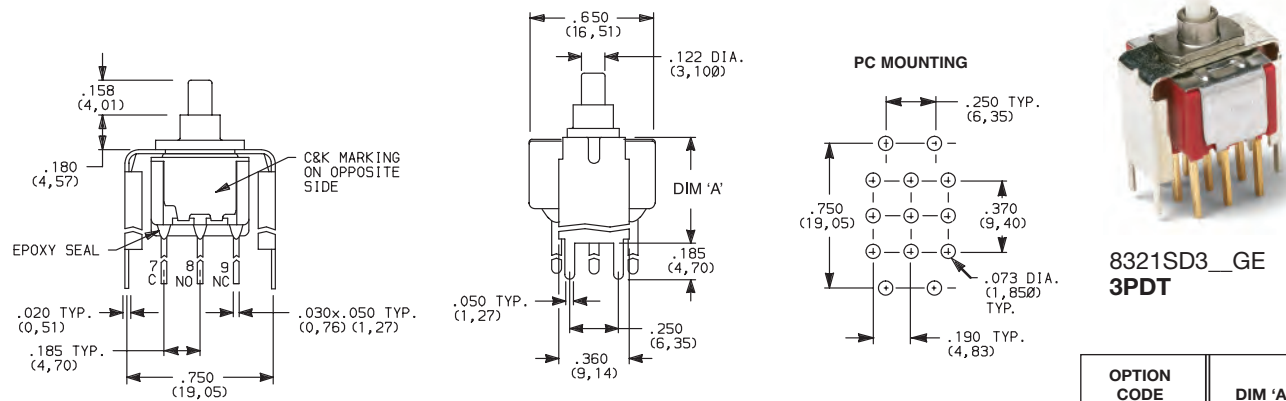

Not available with JXX actuators and I seal.

V2, V7, V8 VERTICAL MOUNT, V-BRACKET

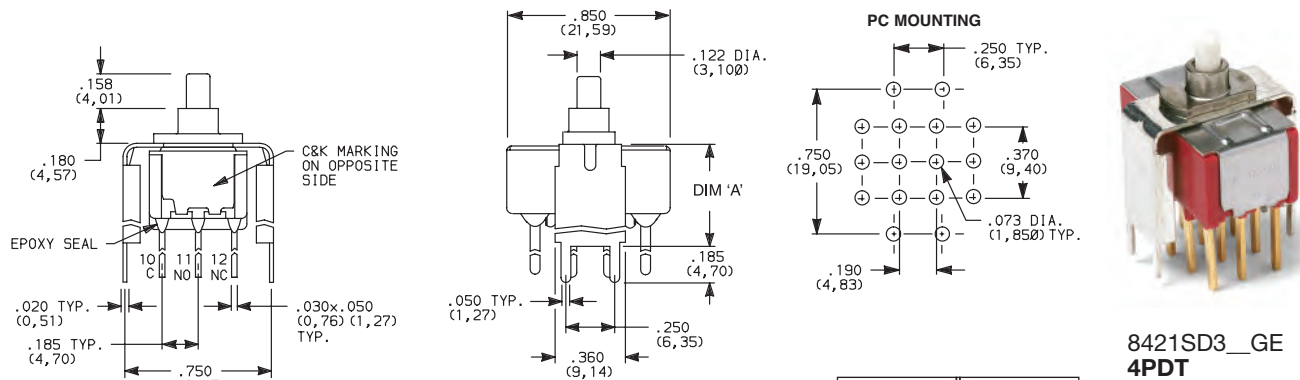

Not available with JXX actuators and I seal.

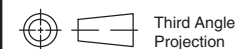

Dimensions are shown: Inches (mm)
Specifications and dimensions subject to change



8020 Series Snap-acting Momentary Pushbutton Switches

TERMINATIONS



Pushbutton

A

V3, V4, V9 VERTICAL MOUNT, V-BRACKET

V31 VERTICAL MOUNT, V-BRACKET, SNAP-IN



8121SD3_GE
SPDT

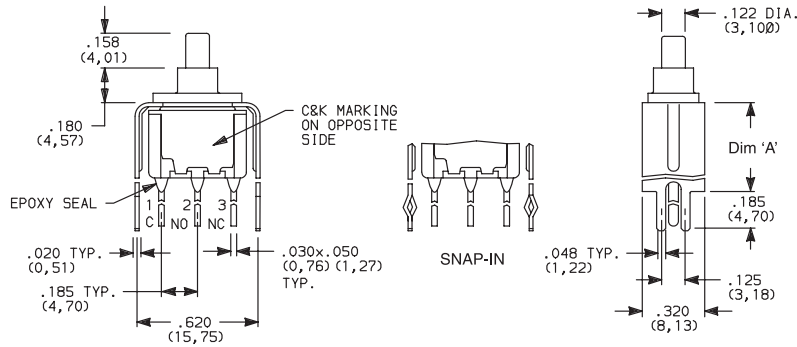

PC MOUNTING

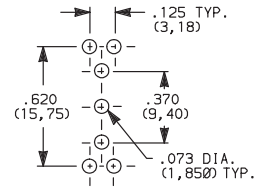

| OPTION CODE | DIM 'A' |
|----------------|---------------|
| V3, V31 | .460 (11,68) |
| V4 | .630 (16,00) |
| V9 | 1.150 (29,21) |

Not available with J8X actuators and I seal.

V3, V4, V9 VERTICAL MOUNT, V-BRACKET

V31 VERTICAL MOUNT, V-BRACKET, SNAP-IN



8221SD3_GE
DPDT

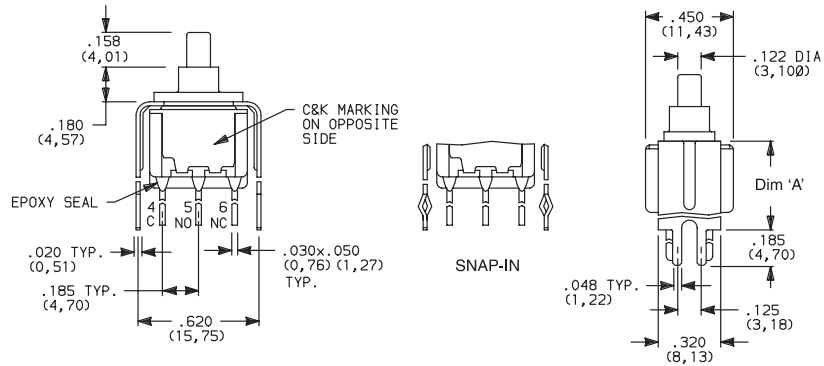

PC MOUNTING

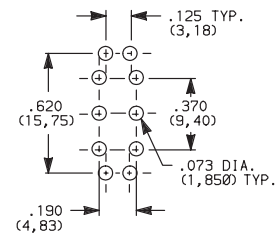

| OPTION CODE | DIM 'A' |
|----------------|---------------|
| V3, V31 | .460 (11,68) |
| V4 | .630 (16,00) |
| V9 | 1.150 (29,21) |

Not available with J8X actuators and I seal.

V4, V9 VERTICAL MOUNT, V-BRACKET



8321SD3V4GE
3PDT

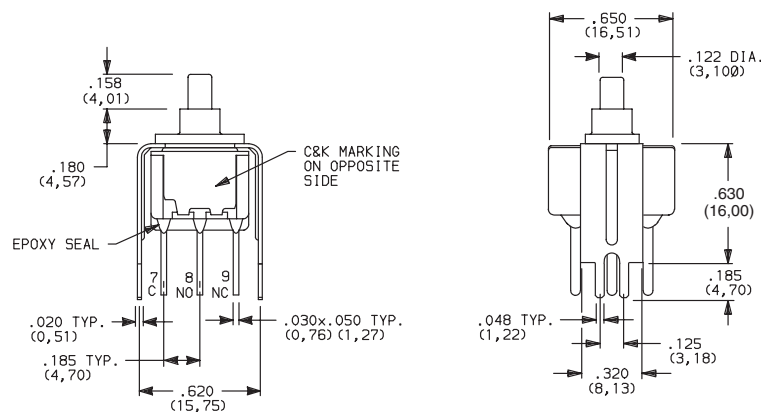

PC MOUNTING

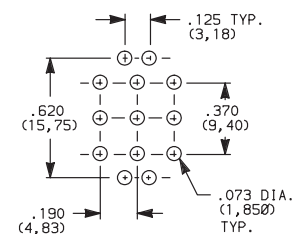

| OPTION CODE | DIM 'A' |
|-------------|---------------|
| V4 | .630 (16,00) |
| V9 | 1.150 (29,21) |

Not available with JXX actuators and I seal.



Dimensions are shown: Inches (mm)
Specifications and dimensions subject to change

8020 Series Snap-acting Momentary Pushbutton Switches



A

Pushbutton

TERMINATIONS

V4, V9 VERTICAL MOUNT, V-BRACKET

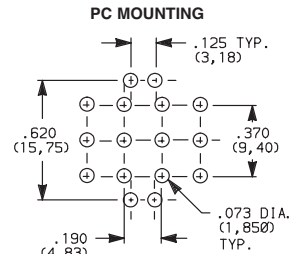
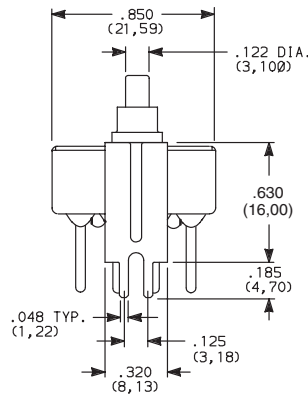
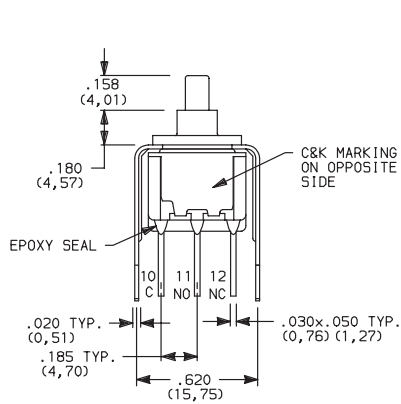

8421SD3V4GE
4PDT

| OPTION CODE | DIM 'A' |
|-------------|---------------|
| V4 | .630 (16,00) |
| V9 | 1.150 (29,21) |

Not available with JXX actuators and I seal.

CONTACT MATERIAL

| OPTION CODE | CONTACT MATERIAL | TERMINAL PLATING | RATINGS | |
|-------------|---------------------------------|------------------------|--------------------------------|---|
| B | GOLD ¹ | GOLD ¹ | LOW LEVEL/DRY CIRCUIT | 8x25 MODELS ONLY: 0.4 MAX. @ 20 V AC OR DC MAX. |
| P | | MATTE-TIN ⁴ | | |
| G | GOLD OVER SILVER ^{2,3} | GOLD ³ | LOW LEVEL/DRY CIRCUIT OR POWER | 8X21, U8X1 MODELS ONLY: 0.4 VA MAX @ 20 V AC OR DC MAX. OR 1 AMP @ 120 V AC OR 28 V DC. |
| R | | MATTE-TIN ⁴ | | |

* Note: See Technical Data section of this catalog for RoHS compliant and compatible definitions and specifications.

- ¹ ALL CONTACTS & TERMINALS: Copper alloy, with gold plate over nickel plate.
- ² N.O. AND N.C. CONTACTS: Coin silver, with gold plate over nickel plate.
- ³ COMMON CONTACTS & ALL TERMINALS: Copper alloy, with gold plate over nickel plate.
- ⁴ TERMINALS: Copper alloy, with matte-tin over nickel plate.

NOTE: Any models supplied with B, P, R or G contact material are RoHS compliant.

U811-U841 models with all options (except R, R2 terminations) when ordered with mandatory G or R contact material.

B or P contact material must be ordered with 8X25 models.

G or R contact material must be ordered with 8X21, U8X1 models.

P or R contact material not available with Z, Z3 terminations.

SEAL

E EPOXY SEAL

I EPOXY POTTED BASE

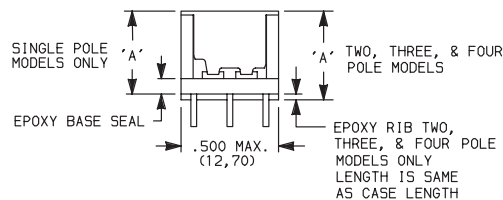
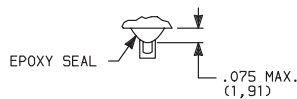

| NO. POLES | DIM 'A' |
|-----------|--------------|
| SP | .410 (10,41) |
| DP | .440 (11,18) |
| 3P | .505 (12,83) |
| 4P | .505 (12,83) |

NOTE: Available with C, W-W4, Z, Z3 terminations only.



Third Angle Projection



Dimensions are shown: Inches (mm)
Specifications and dimensions subject to change

www.ck-components.com



8020 Series Snap-acting Momentary Pushbutton Switches

Pushbutton
A

AVAILABLE HARDWARE

Cap

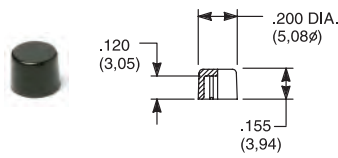

PART NO.

- 708901000 WHITE
- 708902000 BLACK
- 708903000 RED
- 708904000 ORANGE
- 708905000 YELLOW
- 708906000 GREEN
- 708907000 BLUE
- 708909000 GRAY

Material: Nylon
Finish: Gloss

Cap

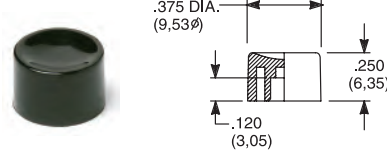

PART NO.

- 752701000 WHITE
- 752702000 BLACK
- 752703000 RED
- 752704000 ORANGE
- 752705000 YELLOW
- 752706000 GREEN
- 752707000 BLUE
- 752709000 GRAY

Material: Nylon
Finish: Gloss

Cap

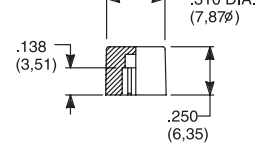

PART NO.

- 801801000 WHITE
- 801802000 BLACK
- 801803000 RED
- 801804000 ORANGE
- 801805000 YELLOW
- 801806000 GREEN
- 801807000 BLUE
- 801809000 GRAY

Material: Nylon
Finish: Gloss

Cap, Snap-fitting plunger

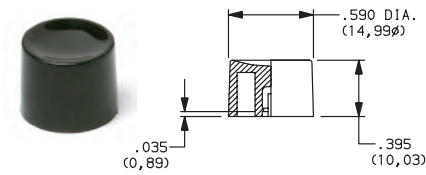

PART NO.

- 452D01000 WHITE
- 452D02000 BLACK
- 452D03000 RED
- 452D04000 ORANGE
- 452D05000 YELLOW
- 452D06000 GREEN
- 452D07000 BLUE
- 452D09000 GRAY

Material: Nylon
Finish: Gloss

Cap, Snap-fitting plunger

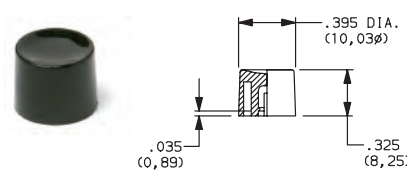

PART NO.

- 894101000 WHITE
- 894102000 BLACK
- 894103000 RED
- 894104000 ORANGE
- 894105000 YELLOW
- 894106000 GREEN
- 894107000 BLUE
- 894109000 GRAY

Material: Nylon
Finish: Gloss

Cap, J80, J81, J82, J83 & J84 options only

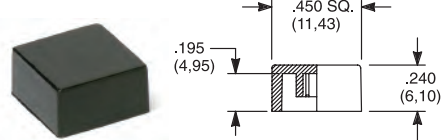

PART NO.

- 484601000 WHITE
- 484602000 BLACK
- 484603000 RED
- 484604000 ORANGE
- 484605000 YELLOW
- 484606000 GREEN
- 484607000 BLUE
- 484609000 GRAY

Material: Nylon
Finish: Gloss

PART NO.

- 798201000 WHITE
- 798202263 BLACK
- 798203000 RED
- 798204000 ORANGE
- 798205000 YELLOW
- 798206000 GREEN
- 798207000 BLUE
- 798209000 GRAY

Material: Nylon
Finish: Matte

Frame



PART NO.

- 615602263 BLACK

Material: Nylon
Finish: Matte

Frame



PART NO.

- 613302263 BLACK

Material: Nylon
Finish: Matte

Cap, J85 & J95 options only

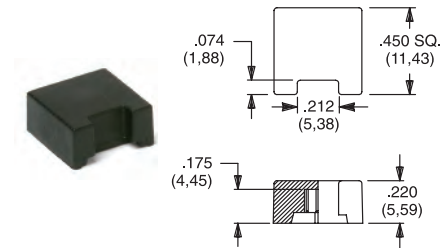

PART NO.

- 459701000 WHITE
- 459702000 BLACK
- 459703000 RED
- 459704000 ORANGE
- 459705000 YELLOW
- 459706000 GREEN
- 459707000 BLUE
- 459709000 GRAY

Material: Nylon
Finish: Gloss

PART NO.

- 476801000 WHITE
- 476802000 BLACK
- 476803000 RED
- 476804000 ORANGE
- 476805000 YELLOW
- 476806000 GREEN
- 476807000 BLUE
- 476809000 GRAY

Material: Nylon
Finish: Matte

Fits Z3 Termination female connector



PART NO.

- 530100000

Available in loose pieces.

NOTE: Additional nuts, locking rings and lockwashers available separately, see section "Technical Data and Additional Hardware".
Other cap & frame colors available, consult Customer Service Center.



Dimensions are shown: Inches (mm)
Specifications and dimensions subject to change



8020 Series Snap-acting Momentary Pushbutton Switches



A Pushbutton

AVAILABLE HARDWARE

Frames snap into panel opening and are independent from switch mounting. Accurate positioning of the PC mounted switch relative to the panel opening is necessary to provide proper clearance between actuator and frame. Available in two basic styles and four panel thicknesses .047-.125 in. Material: Nylon. Finish: Matte.

TYPICAL APPLICATION

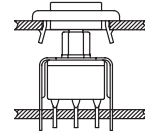

| .047" (1,19) PANEL THK. | .062" (1,57) PANEL THK. | .090" (2,29) PANEL THK. | .125" (3,18) PANEL THK. |
|------------------------------|------------------------------|------------------------------|------------------------------------|
| PART NO. 432502263 | PART NO. 432602263 | PART NO. 432702263 | PART NO. 432802263 BLACK |

PANEL MOUNTING

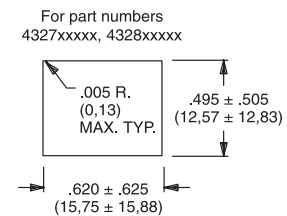
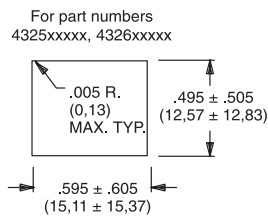

Panel Inserts

Above frames (part nos. 432XXXXXX) are also available with insert which accepts LED for indicator light assembly. Order insert separately from frame. Blank insert panel (without hole for LED) also available. **LED not included.**

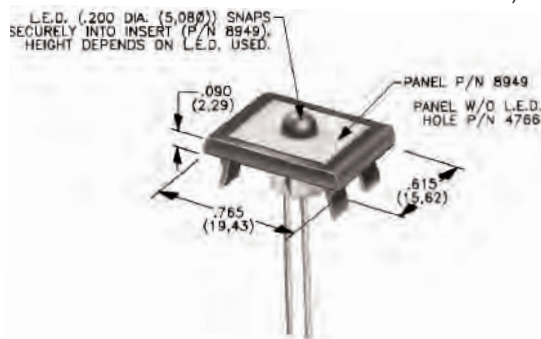

PANEL INSERT WITH HOLE FOR LED

PART NO.
894902000

BLANK PANEL INSERT WITHOUT HOLE FOR LED

PART NO.
476602000 BLACK

Special colors, custom markings available, consult Customer Service Center.

LED INFORMATION

SWITCHES WITH LED SUPPLIED: J85, J95 OPTIONS:

Rectangular LEDs are supplied on 8020 Series pushbutton switches with J85 and J95 options. These LEDs are factory installed and are not replaceable. The following specifications apply:

| OPTION CODE | COLOR | TYP. INTENSITY | TYP. FORWARD VOLTAGE | TYP. FORWARD CURRENT | MAX RATINGS AT 25°C AMBIENT TEMPERATURE | | |
|-------------|--------|----------------|----------------------|----------------------|---|----------------------------|-------------------|
| | | | | | FORWARD VOLTAGE | CONTINUOUS FORWARD CURRENT | POWER DISSIPATION |
| 6 | Green | 1.0 mcd | 2.1 V | 20 mA | 2.5 V | 50 mA | 125 mW |
| 3 | Red* | 0.5 mcd | | 10 mA | | 30 mA | 75 mW |
| 5 | Yellow | 4.0 mcd | | 20 mA | | 50 mA | 125 mW |

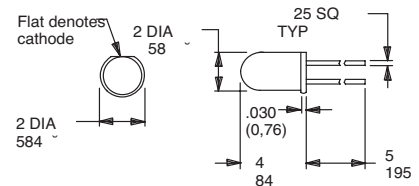

Suggested LED for J82 & J84 options
Dimensions for reference only

Process Information: Soldering to LED leads must be completed within 5 seconds at 500°F (260°C) maximum.

Caution: Circuit elements must limit forward current of LED to 50mA max. continuous.
* Extra-bright red LED available (typ. intensity 4.5 mcd), consult Customer Service Center.
LEDs are not supplied with J82, J84 options. LED snaps into switch frame surrounding actuator and is wired externally.

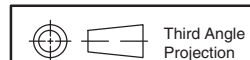

Dimensions are shown: Inches (mm)
Specifications and dimensions subject to change





A

Pushbutton

E010 Series Sealed Momentary Pushbutton Switches

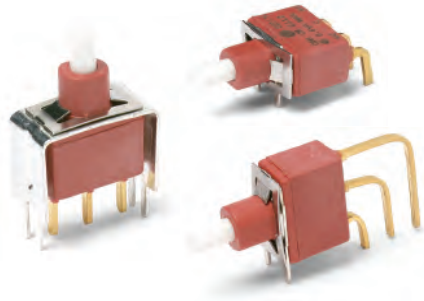

Features/Benefits

- Process sealed, withstands soldering and cleaning
- Long life contact design
- Snap-fitting plunger available, accepts a variety of caps
- RoHS compliant models available

Typical Applications

- Instrumentation
- Telecommunications and networking equipment
- Computers and peripherals



Models Available

Specifications

CONTACT RATING: Q contact material: 4 AMPS @ 125 V AC or 28 V DC. See page A-50 for additional ratings.

ELECTRICAL LIFE: 40,000 make-and-break cycles at full load.

CONTACT RESISTANCE: Below 20 mΩ typ. initial @ 2-4 V DC, 100 mA, for both silver and gold plated contacts.

INSULATION RESISTANCE: 10⁹Ω min.

DIELECTRIC STRENGTH: 1000 Vrms min. @ sea level.

OPERATING TEMPERATURE: -30°C to 75°C.

CAP INSTALLATION FORCE: 10 lbs. max. permissible.

SOLDERABILITY: Per MIL-STD-202F method 208D, or EIA RS-186E method 9 (1 hour steam aging).

NOTE: Any models supplied with P, Q, B or G contact material are RoHS compliant.

NOTE: Specifications and materials listed above are for switches with standard options. For information on specific and custom switches, consult Customer Service Center.

Materials

CASE & BUSHING: Glass filled nylon 6/6, flame retardant (UL 94V-0).

PLUNGER: Glass filled nylon or glass filled polyester (PBT) (UL 94V-0), with internal o-ring seal standard.

SWITCH SUPPORT: Brass or steel, matte-tin plated.

SWITCH SUPPORT RETAINER: Stainless steel.

END CONTACTS: Q contact material: Coin silver, silver plated. See A-50 for additional ratings.

CENTER CONTACTS & ALL TERMINALS: Q contact material: Copper alloy, silver plated. See page A-50 for additional ratings.

TERMINAL SEAL: Epoxy.

HARDWARE: Nut & locking ring-Brass, nickel plated. Lockwasher-Steel, nickel plated.

Build-A-Switch

To order, simply select desired option from each category and place in the appropriate box. Available options are shown and described on pages A-47 thru A-51. For additional options not shown in catalog, consult Customer Service Center. All models are process sealed to withstand machine soldering temperatures and pressure wash cleaning methods.

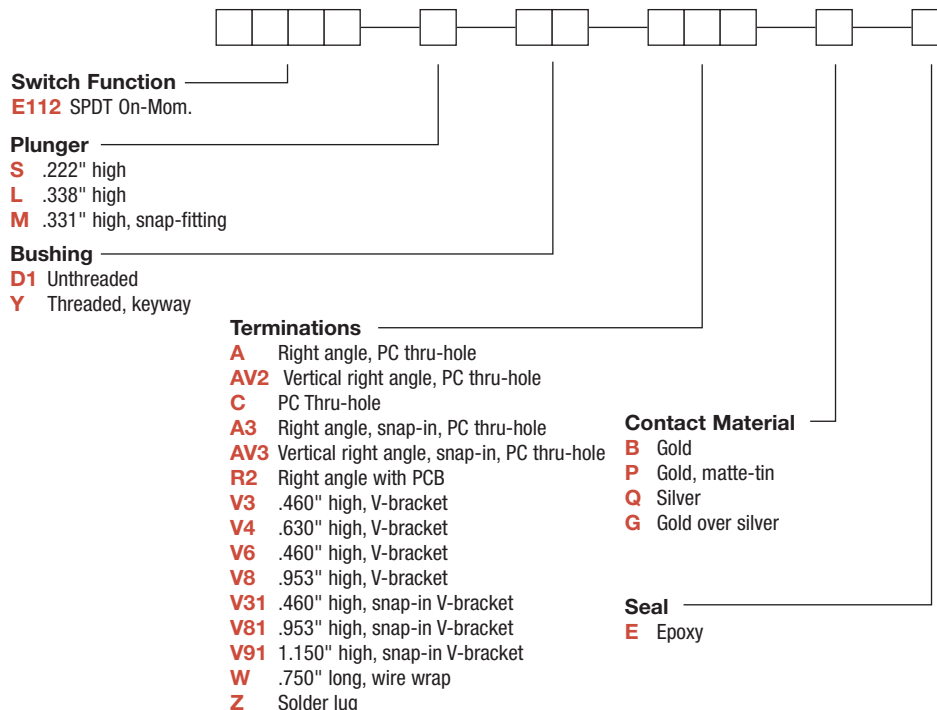

Dimensions are shown: Inches (mm)
Specifications and dimensions subject to change

E010 Series Sealed Momentary Pushbutton Switches



A

Pushbutton

SWITCH FUNCTION

| NO. POLES | MODEL NO. | SWITCH FUNCTION | | CONNECTED TERMINALS | | SCHEMATIC |
|--------------------|-------------|-----------------|----------|---------------------|---------|------------------------------|
| | | POS. 1 | POS. 2 | POS. 1 | POS. 2 | |
| SP | E112 | ON | MOM. | 2-1 | 2-3 | SPDT NC 1 2 (COMM) 3 NO |
| <p>SPDT</p> | | | | | | |

MOM. = Momentary

All models with all options when ordered with G or Q contact material.

PLUNGER

S .218" HIGH

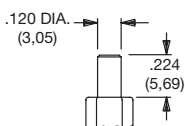

Standard with D1 bushing (as shown).

† Subtract .100 (2,54) from plunger length when ordered with Y bushing.

L .338" HIGH

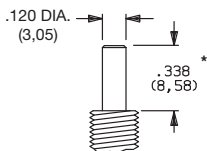

Standard with Y bushing (as shown).

** Add .100 (2,54) from plunger length when ordered with D1 bushing.

M .331" HIGH, SNAP-FITTING

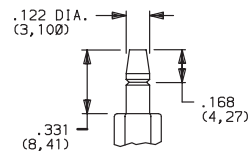

NOTE: Caps available for all plunger options, see pages A-50 and A-51.

BUSHING

D1 UNTHREADED

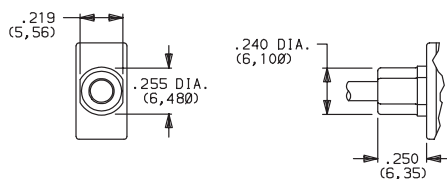

S plunger standard with D1 bushing.

Y THREADED, KEYWAY

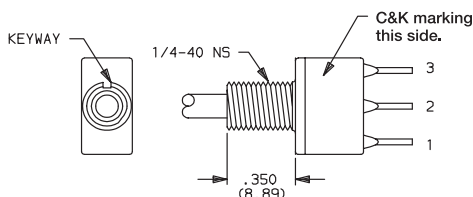

L plunger standard with Y bushing. Available only with C, Z terminations.
Hardware: One dress nut part number 299D01201, one hex nut and lockwasher supplied standard.
Withstands 4 in./lbs. without distortion.

PANEL MOUNTING

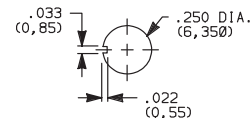

NOTE: Internal o-ring actuator seal standard for all bushing options.

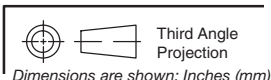

Dimensions are shown: Inches (mm)
Specifications and dimensions subject to change



E010 Series Sealed Momentary Pushbutton Switches

TERMINATIONS



Pushbutton

A

C PC THRU-HOLE

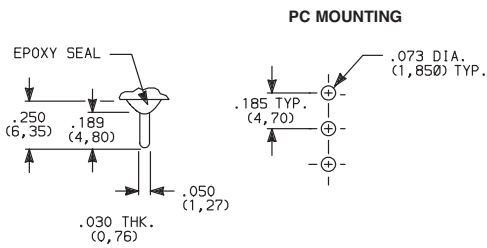

SPDT

Z SOLDER LUG

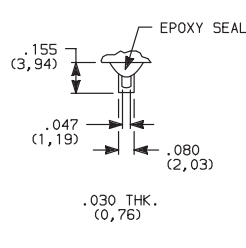

SPDT

Not available with P contact materials.

W WIRE WRAP

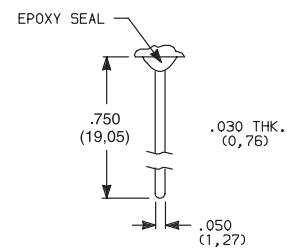

SPDT

A RIGHT ANGLE, PC THRU-HOLE



**E112SD1ABE
SPDT**

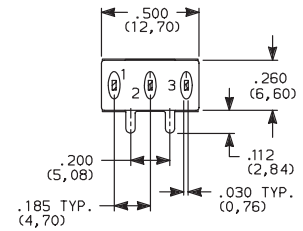
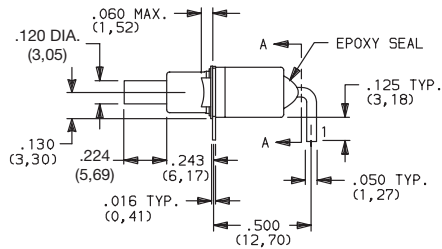
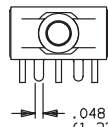

SECTION A-A

A3 RIGHT ANGLE, SNAP-IN, PC THRU-HOLE

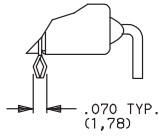
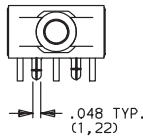

AW RIGHT ANGLE, EXTENDED, PC THRU-HOLE

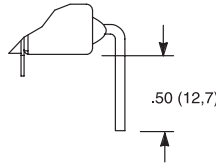

PC MOUNTING

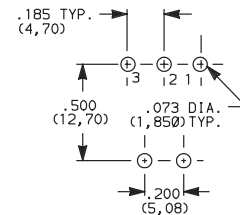

NOTE: Terminal bend radii and lead-in manufacturing option. Available with D1 bushing only.

AV2 VERTICAL RIGHT ANGLE, PC THRU-HOLE, .150" PITCH

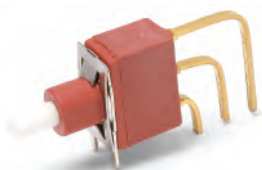

**E112SD1AV2BE
SPDT**

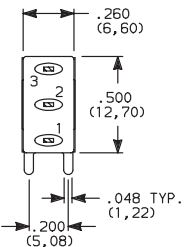
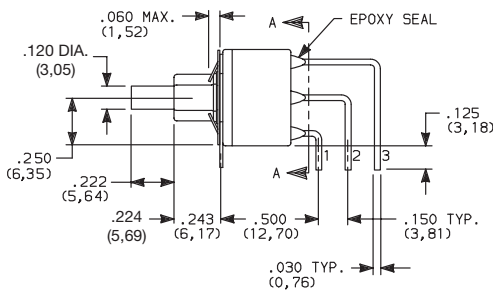
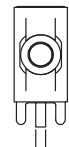

SECTION A-A

AV3 VERTICAL RIGHT ANGLE, SNAP-IN, PC THRU-HOLE, .150" PITCH

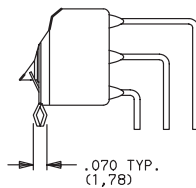
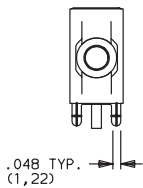

PC MOUNTING

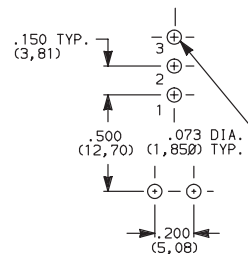

NOTE: Terminal bend radii and lead-in manufacturing option. Available with D1 bushing only.



Dimensions are shown: Inches (mm)
Specifications and dimensions subject to change

E010 Series Sealed Momentary Pushbutton Switches



A

Pushbutton

TERMINATIONS

R2 RIGHT ANGLE WITH PCB

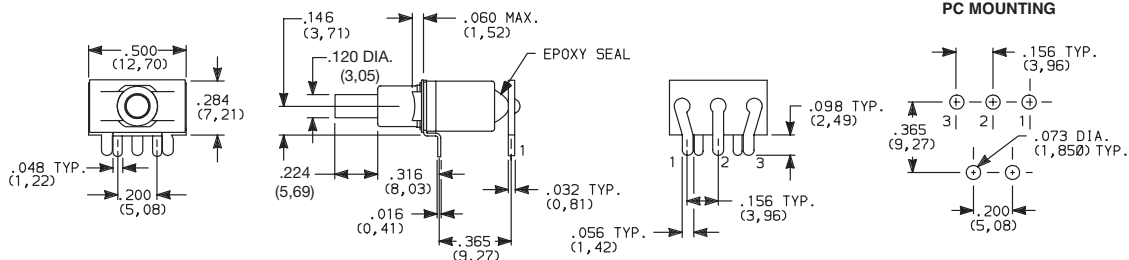

E112SD1R2BE
SPDT

NOTE: Available with D1 bushing and B contact material only.

V3, V4 VERTICAL MOUNT, V-BRACKET

V31, V91 VERTICAL MOUNT, V-BRACKET, SNAP-IN

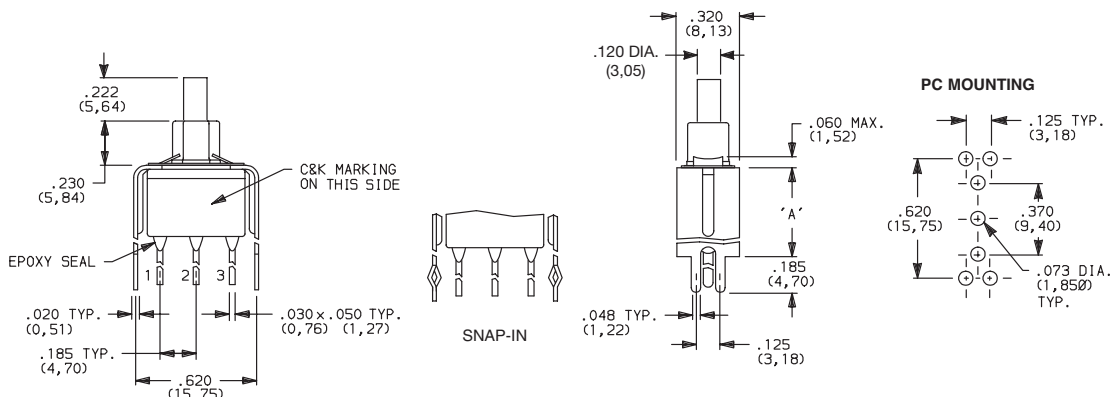

E112SD1_BE
SPDT

| OPTION CODE | DIM 'A' |
|-------------|---------------|
| V3, V31 | .460 (11,68) |
| V4 | .630 (16,00) |
| V91 | 1.150 (29,21) |

NOTE: Available with D1 bushing only.

V6, V8 VERTICAL MOUNT, V-BRACKET

V81 VERTICAL MOUNT, V-BRACKET, SNAP-IN

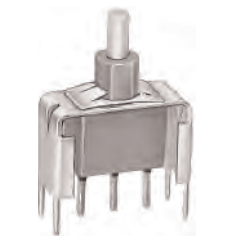
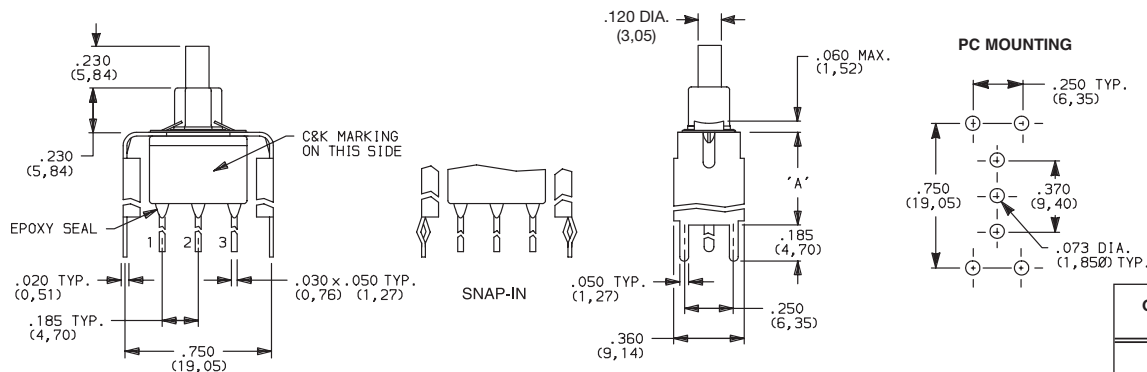

E112SD1_BE
SPDT

| OPTION CODE | DIM 'A' |
|-------------|--------------|
| V6 | .460 (11,68) |
| V8, V81 | .953 (24,21) |

NOTE: Available with D1 bushing only.



Third Angle
Projection



Dimensions are shown: Inches (mm)
Specifications and dimensions subject to change



E010 Series Sealed Momentary Pushbutton Switches

Pushbutton
A

CONTACT MATERIAL

| OPTION CODE | CONTACT MATERIAL | TERMINAL PLATING | RATINGS | |
|-------------|---------------------------------|------------------------|--------------------------------|--|
| B | GOLD ¹ | GOLD ¹ | LOW LEVEL/DRY CIRCUIT | 0.4 VA MAX. @ 20 V AC OR DC MAX. |
| P | | MATTE-TIN ⁶ | | |
| Q | SILVER ^{4,5} | SILVER ⁵ | POWER | 4 AMPS @ 125 V AC OR 28 V DC. |
| G | GOLD OVER SILVER ^{2,3} | GOLD ³ | LOW LEVEL/DRY CIRCUIT OR POWER | 0.4 VA MAX. @ 20 V AC OR DC MAX. OR 4 AMPS @ 125 V AC OR 28 V DC. |

* Note: See Technical Data section of this catalog for RoHS compliant and compatible definitions and specifications.

- ¹ CONTACTS & TERMINALS: Copper alloy, with gold plate over nickel plate.
- ² END CONTACTS: Coin silver, with gold plate over nickel plate.
- ³ CENTER CONTACTS & ALL TERMINALS: Coin silver, with gold plate over nickel plate.
- ⁴ END CONTACTS: Coin silver, silver plated.
- ⁵ CENTER CONTACTS & ALL TERMINALS: Copper alloy, silver plated.
- ⁶ TERMINALS: Copper alloy, with matte-tin over nickel plate.

NOTE: Any models supplied with P, Q, B or G contact material are RoHS compliant.

All models with all options when ordered with G or Q contact material.

B contact material standard with all terminations except C, Z.

B contact material must be ordered with R2 terminations.

Q contact material standard with C, Z terminations.

P contact materials not available with Z terminations.

SEAL

E EPOXY SEAL

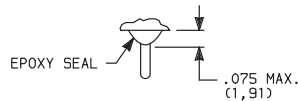

AVAILABLE HARDWARE

Cap

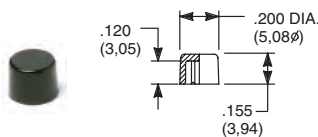

PART NO.
708901000 WHITE
708902000 BLACK
708903000 RED

Material: Nylon
 Finish: Gloss

Cap

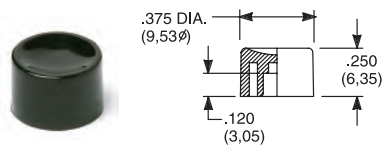

PART NO.
752701000 WHITE
752702000 BLACK
752703000 RED

Material: Nylon
 Finish: Gloss

Cap

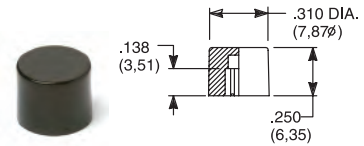

PART NO.
801801000 WHITE
801802000 BLACK
801803000 RED

Material: Nylon
 Finish: Gloss

NOTE: Additional nuts, locking rings and lockwashers available separately, see section "Technical Data and Additional Hardware". Other cap colors available, consult Customer Service Center.



Dimensions are shown: Inches (mm)
 Specifications and dimensions subject to change



E010 Series Sealed Momentary Pushbutton Switches



A

Pushbutton

AVAILABLE HARDWARE

Cap, Snap-fitting plunger

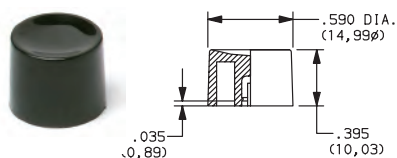

PART NO.
452D01000 WHITE
452D02000 BLACK
452D03000 RED
 Material: Nylon
 Finish: Gloss

Cap, Snap-fitting plunger

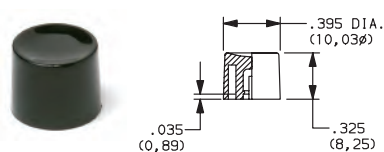

PART NO.
894101000 WHITE
894102000 BLACK
894103000 RED
 Material: Nylon
 Finish: Gloss

Cap

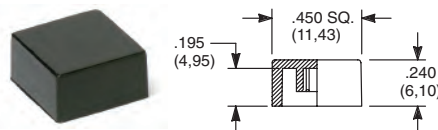

PART NO.
484601000 WHITE
484602000 BLACK
484603000 RED
 Material: Nylon
 Finish: Gloss

PART NO.
798201000 WHITE
798202263 BLACK
798203000 RED
 Material: Nylon
 Finish: Matte

NOTE: Additional nuts, locking rings and lockwashers available separately, see section "Technical Data and Additional Hardware".
 Other cap colors available, consult Customer Service Center.

Frames snap into panel opening and are independent from switch mounting. Accurate positioning of the PC mounted switch relative to the panel opening is necessary to provide proper clearance between actuator and frame. Available in two basic styles and four panel thicknesses .047-.125 in. Material: Nylon. Finish: Matte.

TYPICAL APPLICATION

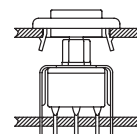

.047" (1,19) PANEL THK. .062" (1,57) PANEL THK. .090" (2,29) PANEL THK. .125" (3,18) PANEL THK.

PART NO. **PART NO.** **PART NO.** **PART NO.**
432502263 **432602263** **432702263** **432802263** BLACK

PANEL MOUNTING

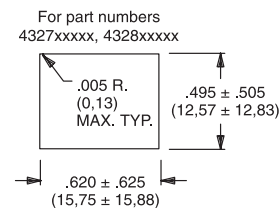
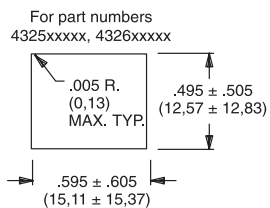

Panel Inserts

Above frames (part nos. 432XXXXXX) are also available with insert which accepts LED for indicator light assembly. Order insert separately from frame. Blank insert panel (without hole for LED) also available. **LED not included.**

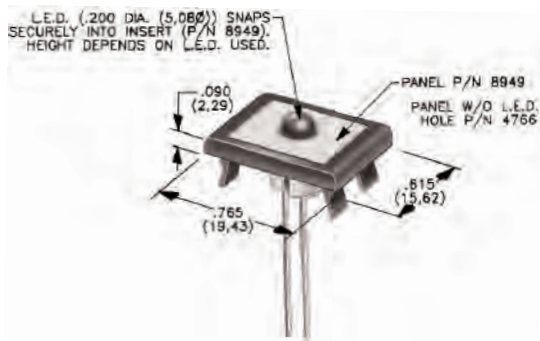

PANEL INSERT WITH HOLE FOR LED

PART NO.
894902000

BLANK PANEL INSERT WITHOUT HOLE FOR LED

PART NO.
476602000 BLACK

Special colors, custom markings available, consult Customer Service Center.



Dimensions are shown: Inches (mm)
 Specifications and dimensions subject to change



www.ck-components.com



A

Pushbutton

8060 Series Alternate Action and Momentary Pushbutton Switches



Features/Benefits

- Long travel
- Available with LED
- Long life contact design
- Epoxy terminal seal compatible with bottom wash cleaning
- RoHS compliant models available

Typical Applications

- Instrumentation
- Computers and peripherals
- Telecommunications and networking equipment



Models Available

Specifications

CONTACT RATING: Q contact material: 6 AMPS @ 120 V AC or 28 V DC; 3 AMPS @ 250 V AC. See page A-59 for additional ratings.

ELECTRICAL LIFE: 50,000 make-and-break cycles at full load.

CONTACT RESISTANCE: Below 20 mΩ typ. initial @ 2-4 V DC, 100 mA, for both silver and gold plated contacts.

INSULATION RESISTANCE: 10⁹Ω min.

DIELECTRIC STRENGTH: 1,000 Vrms min. @ sea level.

OPERATING TEMPERATURE: -30°C to 65°C

SOLDERABILITY: Per MIL-STD-202F method 208D, or EIA RS-186E method 9 (1 hour steam aging).

CAP INSTALLATION FORCE: 10 lbs. maximum permissible.

NOTE: Any models supplied with P, R, S, Q, B or G contact material are RoHS compliant.

NOTE: Specifications and materials listed above are for switches with standard options. For information on specific and custom switches, consult Customer Service Center.

Materials

CASE: Glass filled nylon 6/6 or diallyl phthalate (DAP), flame retardant (UL 94V-0).

PLUNGER: S, S1, S2 Options: Glass filled nylon or glass filled polyester (PBT) (UL 94V-0). L, L1 Options: Brass, nickel plated.

CAP & FRAME: Nylon, black standard.

BUSHING: Brass or zinc, nickel plated.

HOUSING: Stainless steel.

SWITCH SUPPORT: Brass or steel, matte-tin plated.

END CONTACTS: Q contact material: Coin silver, silver plated. See page A-59 for additional contact materials.

CENTER CONTACT & ALL TERMINALS: Q contact material: Copper alloy, silver plated. See page A-59 for additional contact materials.

TERMINAL SEAL: Epoxy. Refer to soldering and cleaning in Technical Data Chapter.

HARDWARE: Nut & Locking Ring: Brass, nickel plated; Lockwasher: Steel, nickel plated.

Build-A-Switch

To order, simply select desired option from each category and place in the appropriate box. Available options are shown and described on pages A-53 thru A-61. For additional options not shown in catalog, consult Customer Service Center. All models have epoxy terminal seal and are compatible with all "bottom-wash" PCB cleaning methods.

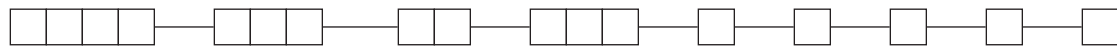

Switch Function

- 8161** SPDT On-On
- 8168** SPDT On-Mom.
- 8261** DPDT On-On

Actuator or Plunger

- S** .710" high plunger with .375" dia. cap
- J80** Snap-in
- J81** Snap-in with frame
- J82** Snap-in with frame for LED
- J86** Snap-in with frame & LED
- L** .740" high plunger with .395" dia. cap
- L1** .740" high plunger with .590" dia. cap
- S1** .615" high plunger with .200" dia. cap
- S2** .710" high plunger with .310" dia. cap

Bushing

- H** .300" high, flat, hi torque
- H9** .300" high, flat, hi torque
- NONE** No bushing choice required
- Y3** 7.6mm, keyway

Terminations

- A** Right angle, PC thru-hole
- AV2** Vertical right angle, PC thru-hole
- C** PC Thru-hole
- Z** Solder lug
- A3** Right angle, snap-in, PC thru-hole
- AV3** Vertical right angle, snap-in, PC thru-hole
- V3** .460" high, V-bracket
- V4** .630" high, V-bracket
- V6** .460" high, V-bracket
- V21** .555" high, snap-in V-bracket
- V31** .460" high, snap-in V-bracket
- W** .750" long, wire wrap
- Z3** Quick connect

Contact Material

- B** Gold
- P** Gold, matte-tin
- Q** Silver
- S** Silver, matte-tin
- G** Gold over silver
- R** Gold over silver, matte-tin

Seal

- E** Epoxy
- I** Epoxy potted base

Cap Color

- 2** Black
- 1** White
- 3** Red
- 4** Orange
- 5** Yellow
- 9** Gray

Frame Color

- 2** Black

LED Color

- 3** Red
- NONE** Models without LED



Dimensions are shown: Inches (mm)
Specifications and dimensions subject to change

8060 Series Alternate Action and Momentary Pushbutton Switches



A
Pushbutton

SWITCH FUNCTION

| NO. POLES | MODEL NO. | SWITCH FUNCTION | | CONNECTED TERMINALS | | SCHEMATIC |
|--|----------------------------|-----------------|------------|---------------------|--------------------|-----------|
| | | POS. 1 | POS. 2 | POS. 1 | POS. 2 | |
| SP | 8161 8168 | ON ON | ON MOM. | 2-3 2-3 | 2-1 2-1 | SPDT |
| <p>SPDT</p> <p>Part number shown: 8161SHZQE</p> | | | | | | |
| DP | 8261 | ON ON | ON ON | 2-3-5-6 2-1,5-4 | 2-1,5-4 2-1,5-4 | DPDT |
| <p>DPDT</p> <p>Part number shown: 8261SHZQE</p> | | | | | | |

MOM. = Momentary

All models **C&K** US with all options when ordered with G or Q contact material.

ACTUATOR—SNAP-IN FRONT MOUNT

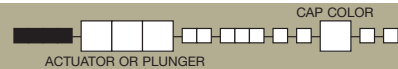

| OPTION CODE | CAP COLOR |
|-------------|-----------|
| 2 | BLACK |
| 1 | WHITE |
| 3 | RED |
| 4 | ORANGE |
| 5 | YELLOW |
| 9 | GRAY |

Cap Finish: matte.
Other colors available, consult Customer Service Center.
Available with C, W, Z or Z3 terminations.
NOTE: Caps & frames available separately, see pages A-60 and A-61.

J80 SNAP-IN

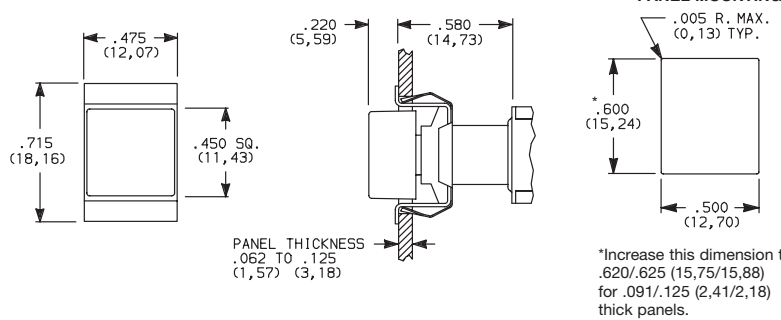

J81 SNAP-IN WITH BLACK FRAME

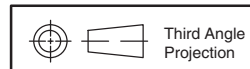
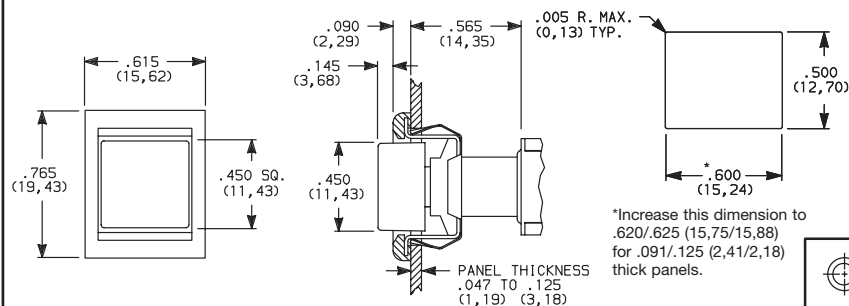

Dimensions are shown: Inches (mm)
Specifications and dimensions subject to change

www.ck-components.com



8060 Series Alternate Action and Momentary Pushbutton Switches

A

Pushbutton

ACTUATOR—SNAP-IN FRONT MOUNT

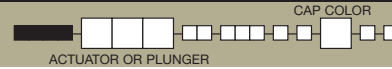

J82 SNAP-IN WITH BLACK FRAME FOR LED

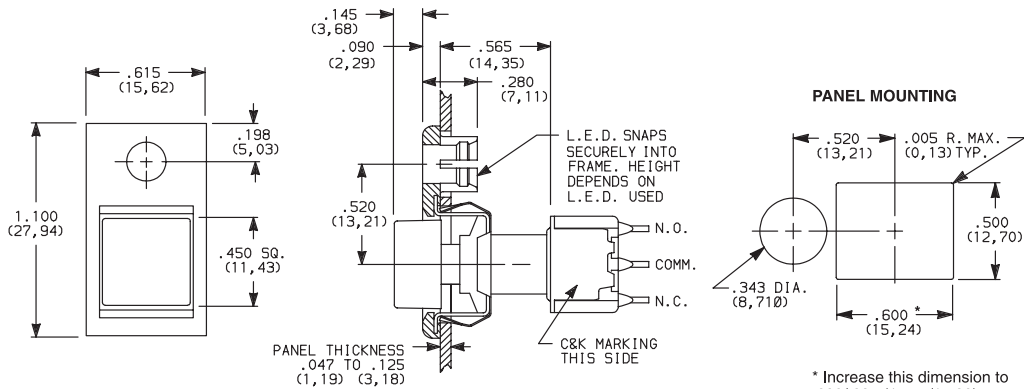

Available with C, W, Z or Z3 terminations.

LED not included.
For LED information, see page A-61.

NOTE: Caps & frames available separately, see pages A-60 and A-61.

Other colors available, consult Customer Service Center.

| OPTION CODE | CAP COLOR |
|-------------|-----------|
| 2 | BLACK |
| 1 | WHITE |
| 3 | RED |
| 4 | ORANGE |
| 5 | YELLOW |
| 9 | GRAY |

* Increase this dimension to .620/.625 (15,75/15,88) for .091/.125 (2,31/3,18) thick panels.

ACTUATOR—SNAP-IN FRONT MOUNT



J86 SNAP-IN WITH BLACK FRAME AND LED



8161J86ZQE223
SPDT

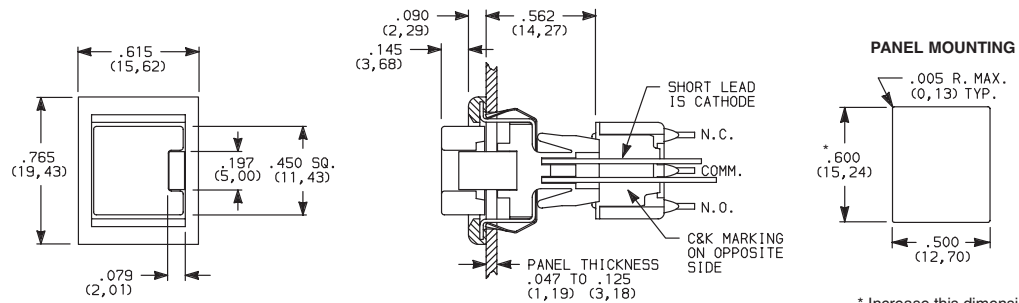

Available with C, W, Z or Z3 terminations and SPDT models only.

NOTE: Caps & frames available separately, see pages A-60 and A-61.

Other colors available, consult Customer Service Center.

| OPTION CODE | CAP COLOR |
|-------------|-----------|
| 2 | BLACK |
| 1 | WHITE |
| 3 | RED |
| 4 | ORANGE |
| 5 | YELLOW |
| 9 | GRAY |

| OPTION CODE | LED COLOR |
|-------------|-----------|
| 3 | RED |

For LED information, see page A-61.



Dimensions are shown: Inches (mm)
Specifications and dimensions subject to change



8060 Series Alternate Action and Momentary Pushbutton Switches



A

Pushbutton



S PLUNGER WITH CAP P/N 7527

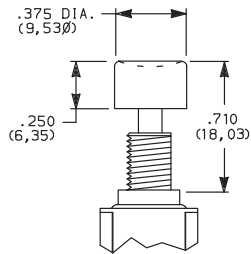

S1 PLUNGER WITH CAP P/N 7089

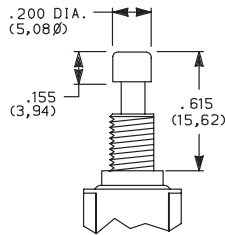

S2 PLUNGER WITH CAP P/N 8018

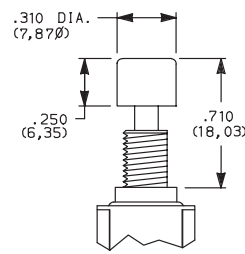

S, S1, S2 plunger dimensions.

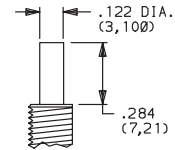

Plunger material: Glass filled nylon or glass filled polyester (UL 94V-0).

L PLUNGER WITH CAP P/N 8941

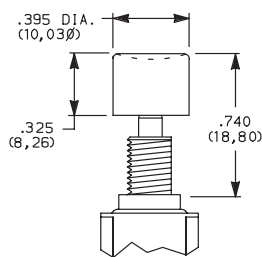

L1 PLUNGER WITH CAP P/N 8940

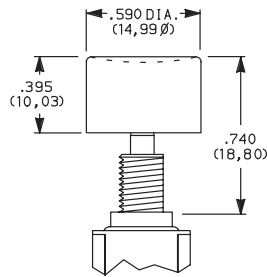

L, L1 plunger dimensions.

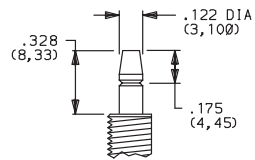

Plunger Material: Brass, chrome plated.

| OPTION CODE | CAP COLOR |
|-------------|-----------|
| 2 | BLACK |
| 1 | WHITE |
| 3 | RED |
| 4 | ORANGE |
| 5 | YELLOW |
| 9 | GRAY |

Cap Finish: gloss. Cap supplied not installed. Other colors available, consult Customer Service Center.

NOTE: When selecting plunger and cap option, bushing selection must also be made, see below.



H .300" HIGH THREADED, FLAT
H9 .300" HIGH UNTHREADED, FLAT

NONE NO BUSHING CHOICE REQUIRED (JXX ACTUATORS)

Y3 7.6mm THREADED, KEYWAY

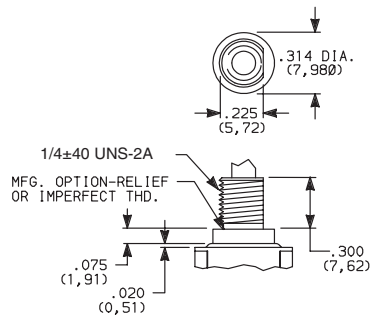

H bushing standard with C, W, Z or Z3 terminations. H9 bushing standard with A, A3, AV2, AV3, or V3-V31 terminations.

Withstands 12 in./lbs. of torque with no distortion.

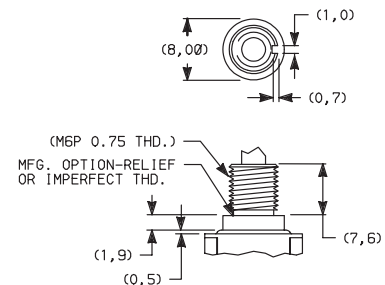

Withstands 12 in./lbs. of torque with no distortion.

NOTE: When selecting bushing option, plunger selection must also be made, see above. No bushing option choice required when any JXX actuator option is selected.

PANEL MOUNTING

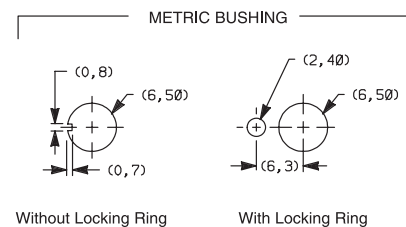
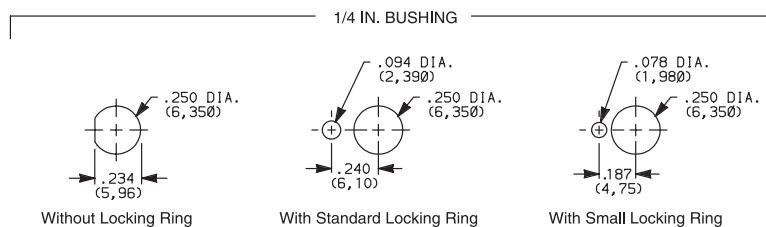

NOTE: Two mounting nuts, locking ring and lockwasher supplied standard with threaded bushings. Optional mounting nut and locking ring styles and finishes available, see section "Technical Data and Additional Hardware".

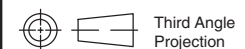

Dimensions are shown: Inches (mm)
Specifications and dimensions subject to change





8060 Series Alternate Action and Momentary Pushbutton Switches

Pushbutton
A

TERMINATIONS

C PC THRU-HOLE

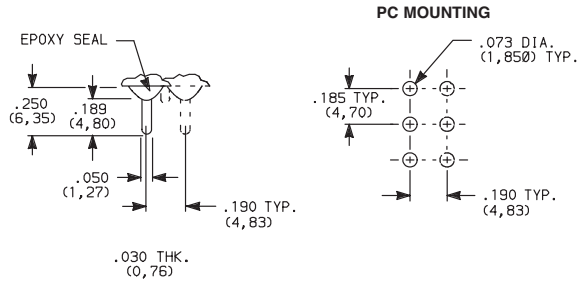

SPDT and DPDT

Z SOLDER LUG

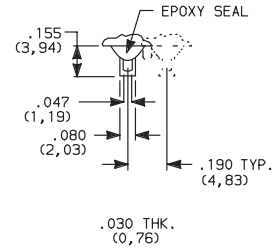

SPDT and DPDT

Not available with P, S or R contact material.

Z3 QUICK CONNECT

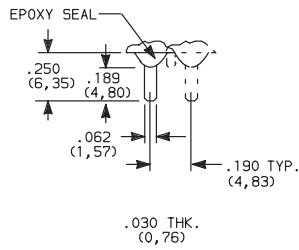

SPDT and DPDT

Not available with P, S or R contact material.
Mating quick connector available;
order part number 530100000, page A-61.

W WIRE WRAP

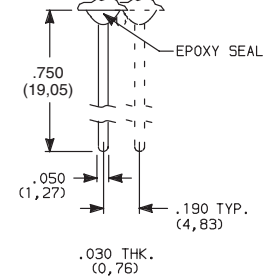

SPDT and DPDT

A RIGHT ANGLE, PC THRU-HOLE



8161SH9ABE2
SPDT

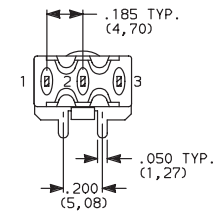
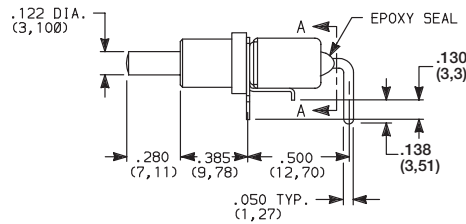
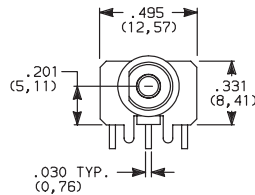

SECTION A-A

A3 RIGHT ANGLE, SNAP-IN, PC THRU-HOLE

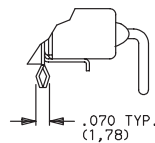
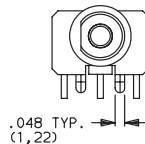

Not available with I seal.
Terminal bend radii and lead-in manufacturing option.

PC MOUNTING

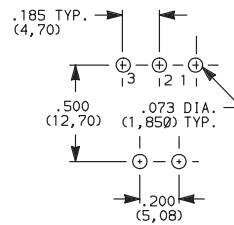

NOTE: PC pattern must clear switch support leg.



Third Angle
Projection

Dimensions are shown: Inches (mm)
Specifications and dimensions subject to change



8060 Series Alternate Action and Momentary Pushbutton Switches



A

Pushbutton

TERMINATIONS

A RIGHT ANGLE, PC THRU-HOLE

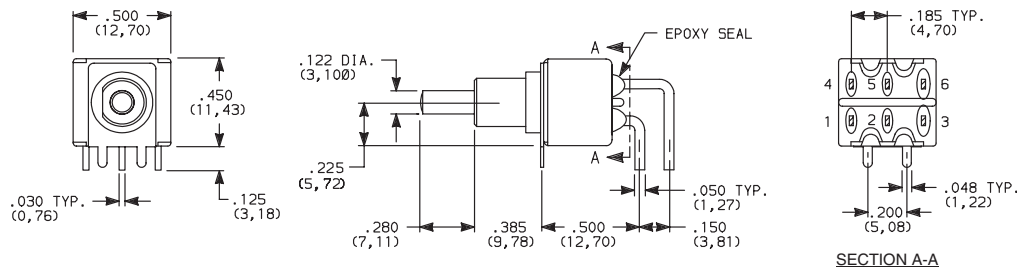

8261SH9ABE2
DPDT

A3 RIGHT ANGLE, SNAP-IN, PC THRU-HOLE

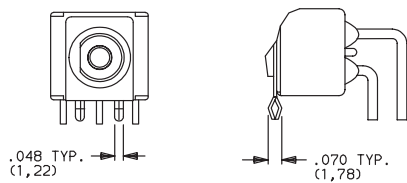

PC MOUNTING

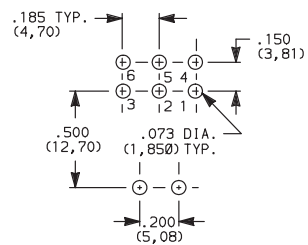

Not available with I seal.
Terminal bend radii and lead-in manufacturing option.

AV2 VERTICAL RIGHT ANGLE, PC THRU-HOLE, .150° PITCH

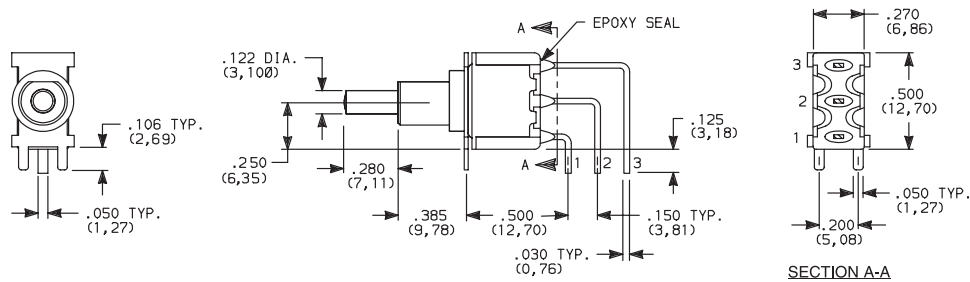

8161SH9AV2BE2
SPDT

AV3 VERTICAL RIGHT ANGLE, SNAP-IN, PC THRU-HOLE, .150° PITCH

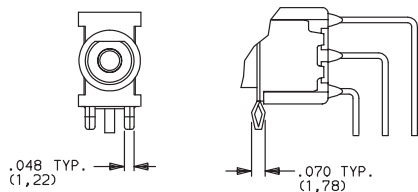

PC MOUNTING

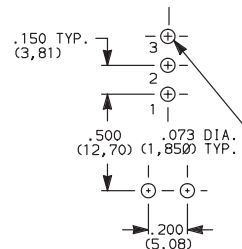

Not available with I seal.
Terminal bend radii and lead-in manufacturing option.

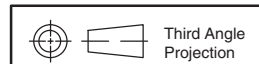

Third Angle
Projection



Dimensions are shown: Inches (mm)
Specifications and dimensions subject to change

www.ck-components.com



8060 Series Alternate Action and Momentary Pushbutton Switches

TERMINATIONS



Pushbutton
A

AV2 VERTICAL RIGHT ANGLE, PC THRU-HOLE, .150" PITCH



**8261SH9AV2BE2
DPDT**

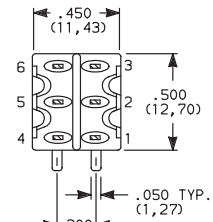
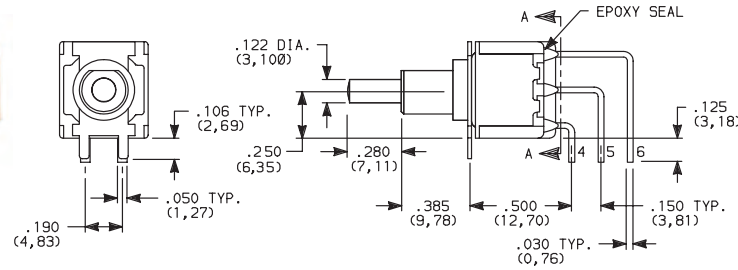

SECTION A-A

AV3 VERTICAL RIGHT ANGLE, SNAP-IN, PC THRU-HOLE, .150" PITCH

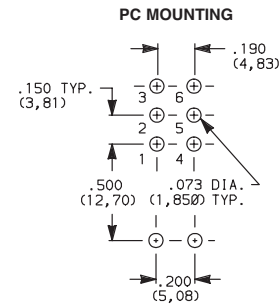
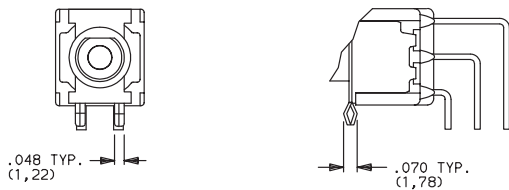

PC MOUNTING

Not available with I seal.
Terminal bend radii and lead-in manufacturing option.

V6 VERTICAL MOUNT, V-BRACKET

V21 VERTICAL MOUNT, V-BRACKET, SNAP-IN



**8161SH9_BE2
SPDT**

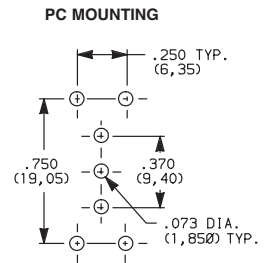
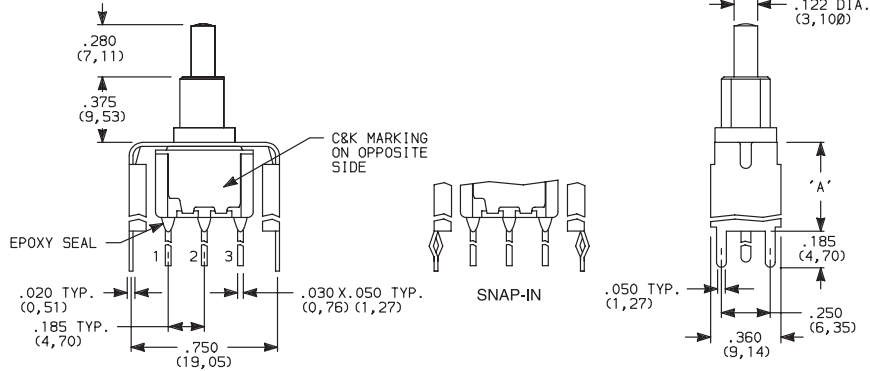

PC MOUNTING

| OPTION CODE | DIM 'A' |
|-------------|--------------|
| V21 | .555 (14,10) |
| V6 | .460 (11,68) |

Not available with I seal.

V6 VERTICAL MOUNT, V-BRACKET

V21 VERTICAL MOUNT, V-BRACKET, SNAP-IN



**8261SH9_BE2
DPDT**

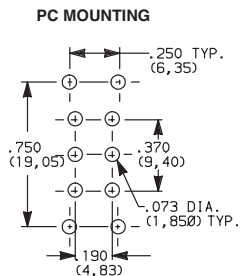
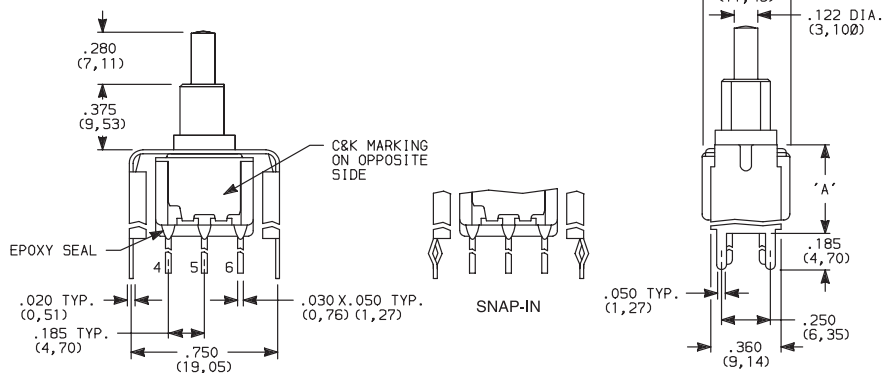

PC MOUNTING

| OPTION CODE | DIM 'A' |
|-------------|--------------|
| V21 | .555 (14,10) |
| V6 | .460 (11,68) |

Not available with I seal.

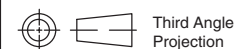

Dimensions are shown: Inches (mm)
Specifications and dimensions subject to change

8060 Series Alternate Action and Momentary Pushbutton Switches



A
Pushbutton

TERMINATIONS

V3, V4 VERTICAL MOUNT, V-BRACKET

V31 VERTICAL MOUNT, V-BRACKET, SNAP-IN

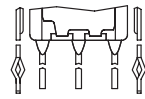
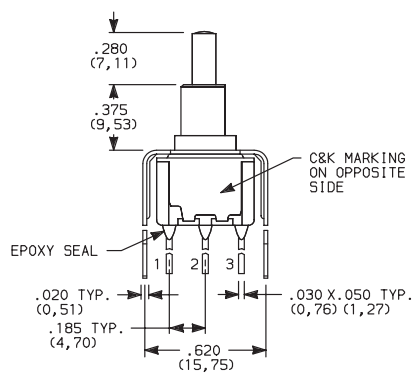

SNAP-IN

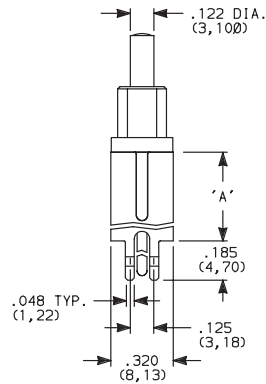

PC MOUNTING

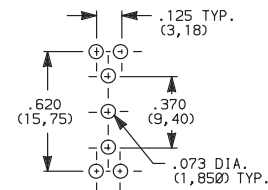

8161SH9_BE2
SPDT

| OPTION CODE | DIM 'A' |
|----------------|--------------|
| V3, V31 | .460 (11,68) |
| V4 | .630 (16,00) |

Not available with I seal.

V3, V4 VERTICAL MOUNT, V-BRACKET

V31 VERTICAL MOUNT, V-BRACKET, SNAP-IN

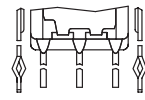
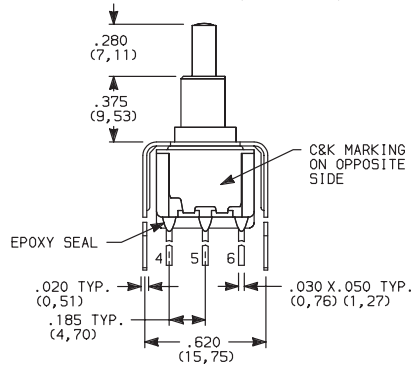

SNAP-IN

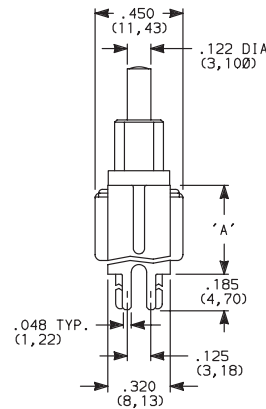

PC MOUNTING

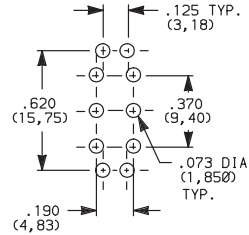

8261SH9_BE2
DPDT

| OPTION CODE | DIM 'A' |
|----------------|--------------|
| V3, V31 | .460 (11,68) |
| V4 | .630 (16,00) |

Not available with I seal.

CONTACT MATERIAL

| OPTION CODE | CONTACT MATERIAL | TERMINAL PLATING | RATINGS | |
|-------------|----------------------|------------------|--------------------------------|---|
| B | GOLD 1 | GOLD 1 | LOW LEVEL/DRY CIRCUIT | 0.4 VA MAX. @ 20 V AC OR DC MAX. |
| P | | MATTE-TIN 6 | | |
| Q | SILVER 4,5 | SILVER 5 | POWER | 6 AMPS @ 120 V AC OR 28 V DC; 3 AMPS @ 250 V AC. |
| S | | MATTE-TIN 6 | | |
| G | GOLD OVER SILVER 2,3 | GOLD 3 | LOW LEVEL/DRY CIRCUIT OR POWER | 0.4 VA MAX @ 20 V AC OR DC MAX. OR 6 AMPS @ 120 V AC OR 28 V DC; 3 AMPS @ 250 V AC. |
| R | | MATTE-TIN 6 | | |

* Note: See Technical Data section of this catalog for RoHS compliant and compatible definitions and specifications.

- CONTACTS & TERMINALS: Copper alloy, with gold plate over nickel plate.
- END CONTACTS: Coin silver, with gold plate over nickel plate.
- CENTER CONTACTS & ALL TERMINALS: Copper alloy, with gold plate over nickel plate.
- END CONTACTS: Coin silver, silver plated.
- CENTER CONTACT & ALL TERMINALS: Copper alloy, silver plated.
- TERMINALS: Copper alloy, with matte-tin over nickel plate.

All models **CAUS** with all options when ordered with S, R, G, or Q contact material.

B contact material standard with all terminations except C, Z & Z3.

Q contact material standard with C, Z & Z3 terminations.

P, S & R contact materials not available with Z & Z3 terminations.

NOTE: Any models supplied with P, S, R, Q, B or G contact material are RoHS compliant.



Third Angle
Projection



Dimensions are shown: Inches (mm)
Specifications and dimensions subject to change



8060 Series Alternate Action and Momentary Pushbutton Switches

SEAL

Pushbutton
A

E EPOXY SEAL

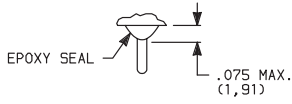

I EPOXY POTTED BASE

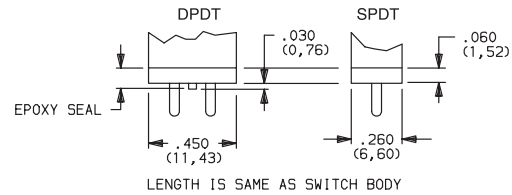

NOTE: Available with C, W, Z, Z3 terminations only.

AVAILABLE HARDWARE

Cap

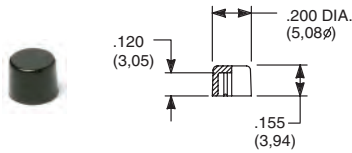

PART NO.

- 708901000 WHITE
- 708902000 BLACK
- 708903000 RED
- 708904000 ORANGE
- 708905000 YELLOW
- 708909000 GRAY

Material: Nylon
Finish: Gloss

Cap

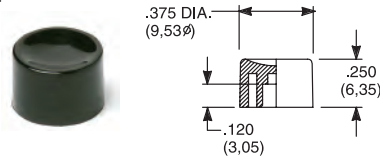

PART NO.

- 752701000 WHITE
- 752702000 BLACK
- 752703000 RED
- 752704000 ORANGE
- 752705000 YELLOW
- 752709000 GRAY

Material: Nylon
Finish: Gloss

Cap

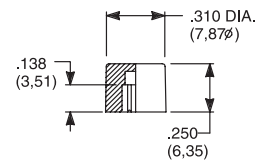

PART NO.

- 801801000 WHITE
- 801802000 BLACK
- 801803000 RED
- 801804000 ORANGE
- 801805000 YELLOW
- 801809000 GRAY

Material: Nylon
Finish: Gloss

Cap, Snap-fitting plunger

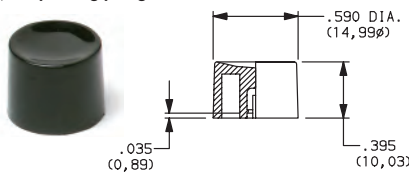

PART NO.

- 452D01000 WHITE
- 452D02000 BLACK
- 452D03000 RED
- 452D04000 ORANGE
- 452D05000 YELLOW
- 452D09000 GRAY

Material: Nylon
Finish: Gloss

Cap, Snap-fitting plunger

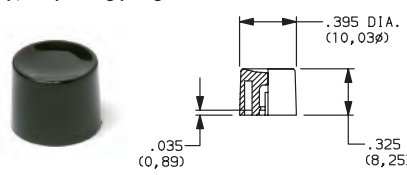

PART NO.

- 894101000 WHITE
- 894102000 BLACK
- 894103000 RED
- 894104000 ORANGE
- 894105000 YELLOW
- 894109000 GRAY

Material: Nylon
Finish: Gloss

Cap, J80, J81 & J82 options only

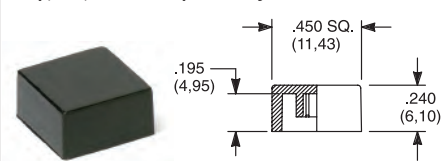

PART NO.

- 484601000 WHITE
- 484602000 BLACK
- 484603000 RED
- 484604000 ORANGE
- 484605000 YELLOW
- 484609000 GRAY

Material: Nylon
Finish: Gloss

PART NO.

- 798201000 WHITE
- 798202263 BLACK
- 798203000 RED
- 798204000 ORANGE
- 798205000 YELLOW
- 798209000 GRAY

Material: Nylon
Finish: Matte

Cap, J86 & J96 options only

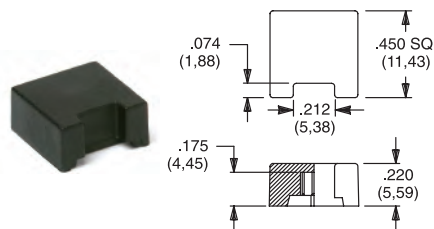

PART NO.

- 459701000 WHITE
- 459702000 BLACK
- 459703000 RED
- 459704000 ORANGE
- 459705000 YELLOW
- 459709000 GRAY

Material: Nylon
Finish: Gloss

PART NO.

- 476801000 WHITE
- 476802000 BLACK
- 476803000 RED
- 476804000 ORANGE
- 476805000 YELLOW
- 476809000 GRAY

Material: Nylon
Finish: Matte

Frame



PART NO.

- 615602263 BLACK

Material: Nylon
Finish: Matte

Frame



PART NO.

- 613302263 BLACK

Material: Nylon
Finish: Matte

NOTE: Additional nuts, locking rings and lockwashers available separately, see section "Technical Data and Additional Hardware".
Other cap & frame colors available, consult Customer Service Center.



Dimensions are shown: Inches (mm)
Specifications and dimensions subject to change



8060 Series Alternate Action and Momentary Pushbutton Switches



A
Pushbutton

AVAILABLE HARDWARE

Fits Z3 Termination
female connector

PART NO.
530100000

Available in loose pieces.



Frames snap into panel opening and are independent from switch mounting. Accurate positioning of the PC mounted switch relative to the panel opening is necessary to provide proper clearance between actuator and frame. Available in two basic styles and four panel thicknesses .047-.125 in. Material: Nylon. Finish: Matte.

TYPICAL APPLICATION

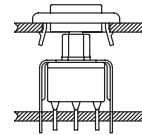

.047" (1,19) PANEL THK. .062" (1,57) PANEL THK. .090" (2,29) PANEL THK. .125" (3,18) PANEL THK.

| | | | |
|-------------------------------------|-------------------------------------|-------------------------------------|---|
| PART NO. 432502263 | PART NO. 432602263 | PART NO. 432702263 | PART NO. 432802263 BLACK |
|-------------------------------------|-------------------------------------|-------------------------------------|---|

PANEL MOUNTING

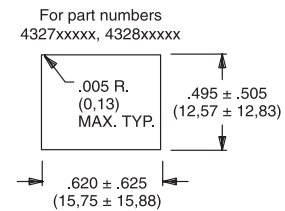
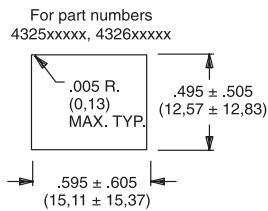

Panel Inserts

Above frames (part nos. 432XXXXXX) are also available with insert which accepts LED for indicator light assembly. Order insert separately from frame. Blank insert panel (without hole for LED) also available. **LED not included.**

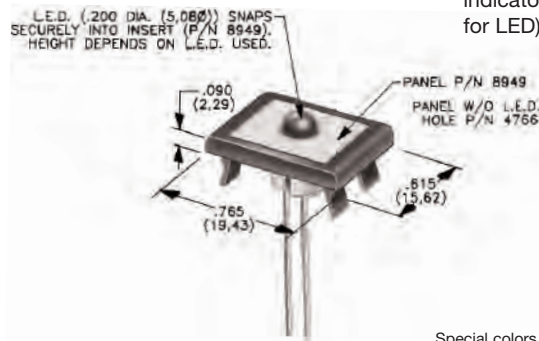

PANEL INSERT
WITH HOLE FOR LED

PART NO.
894902000

BLANK PANEL INSERT
WITHOUT HOLE FOR LED

PART NO.
476602000 BLACK

Special colors, custom markings available, consult Customer Service Center.

LED INFORMATION

SWITCHES WITH LED SUPPLIED: J86 OPTION:

Rectangular LEDs are supplied on 8060 Series pushbutton switches with J86 option. These LEDs are factory installed and are not replaceable. The following specifications apply:

| OPTION CODE | COLOR | TYP. INTENSITY | TYP. FORWARD VOLTAGE | TYP. FORWARD CURRENT | MAX RATINGS AT 25°C AMBIENT TEMPERATURE | | |
|-------------|--------|----------------|----------------------|----------------------|---|----------------------------|-------------------|
| | | | | | FORWARD VOLTAGE | CONTINUOUS FORWARD CURRENT | POWER DISSIPATION |
| 6 | Green | 1.0 mcd | 2.1 V | 20 mA | 2.5 V | 50 mA | 125 mW |
| 3 | Red* | 0.5 mcd | | 10 mA | | 30 mA | 75 mW |
| 5 | Yellow | 4.0 mcd | | 20 mA | | 50 mA | 125 mW |

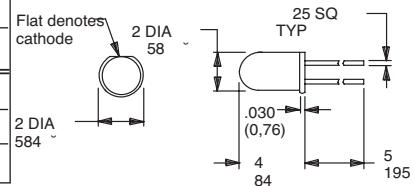

Suggested LED for J82 & J84 options
Dimensions for reference only

Process Information: Soldering to LED leads must be completed within 5 seconds at 500°F (260°C) maximum.

Caution: Circuit elements must limit forward current of LED to 50mA max. continuous.

* Extra-bright red LED available (typ. intensity 4.5 mcd), consult Customer Service Center.

LEDs are not supplied with J82 & J84 options. LED snaps into switch frame surrounding actuator and is wired externally.

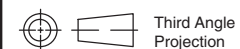

Third Angle
Projection

Dimensions are shown: Inches (mm)
Specifications and dimensions subject to change





A

Pushbutton

8500 Series Subminiature Pushbutton Switches



Features/Benefits

- Pre-travel or over-travel models available
- Ratings up to 3 AMPS
- Reliable contact design
- RoHS compliant

Typical Applications

- Detection
- Telecommunications and networking equipment
- Computers and peripherals



Models Available

Specifications

CONTACT RATING: Q contact material (853X Models): 1 AMP @ 120 V AC or 28 V DC; (855X Models): 3 AMPS @ 120 V AC or 28 V DC. See page A-65 for additional ratings.

ELECTRICAL LIFE:

853X MODELS: 250,000 actuations at full load.
855X MODELS: 10,000 actuations at full load.

CONTACT RESISTANCE: Below 30 mΩ typ. initial @ 2-4 V DC, 100 mA, for both silver and gold plated contacts.

INSULATION RESISTANCE: 10⁹Ω min.

DIELECTRIC STRENGTH: 1,000 Vrms min. @ sea level.

OPERATING TEMPERATURE: -30°C to 65°C.

TORQUE SPECS: T, T1 15/32" bushings - 50 in. lbs max.
All other 1/4 -40 bushing types 12 in. lbs max.

Materials

CASE: Glass filled phenolic or diallyl phthalate (DAP) (UL 94V-0).

PLUNGER: Phenolic or glass filled polyester, black standard(UL94V-0).

CAP & FRAME: Nylon, black, standard.

BUSHING: Brass, nickel plated.

CONTACTS: Q contact material: Coin silver, silver plated. See page A-65 for additional contact materials.

TERMINALS: Q contact material: Copper alloy, silver plated. See page A-65 for additional contact materials.

TERMINAL SEAL: Epoxy.

HARDWARE: Nut: Brass, nickel plated; Lockwasher: Steel, bright nickel plated.

NOTE: Any models supplied with Q, B or G contact material are RoHS compliant.

NOTE: Specifications and materials listed above are for switches with standard options. For information on specific and custom switches, consult Customer Service Center.

Build-A-Switch

To order, simply select desired option from each category and place in the appropriate box. Available options are shown and described on pages A-63 thru A-66. For additional options not shown in catalog, consult Customer Service Center. All models have epoxy terminal seal and are compatible with all "bottom-wash" PCB cleaning methods.

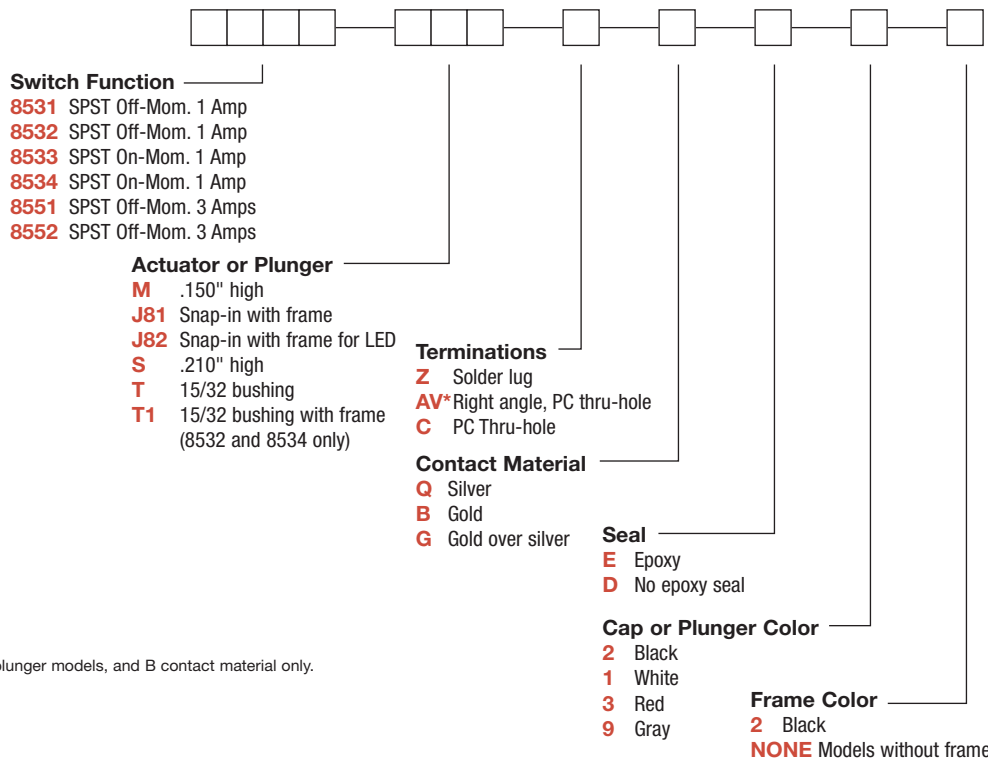

* Available with M or S plunger models, and B contact material only.



Dimensions are shown: Inches (mm)
Specifications and dimensions subject to change

8500 Series Subminiature Pushbutton Switches



A

Pushbutton

SWITCH FUNCTION

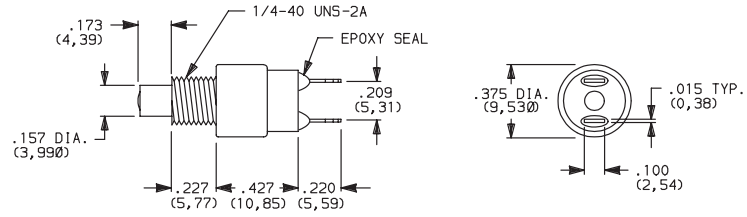
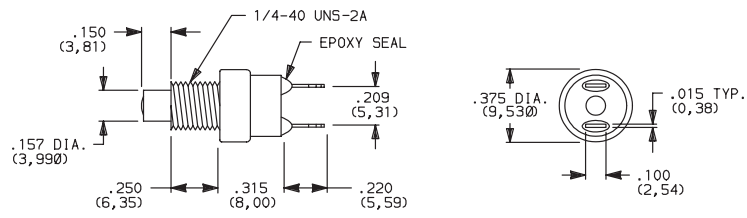
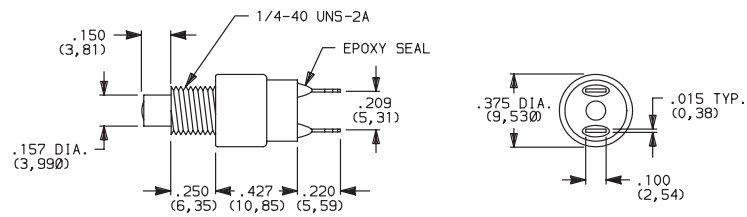
| NO. POLES | MODEL NO. | RATING | SWITCH FUNCTION | | TOTAL TRAVEL | ACTUATION FORCE | SCHEMATIC |
|--|-----------|--------|-----------------|--------|---|----------------------|----------------------|
| | | | POS. 1 | POS. 2 | | | |
| SP | 8531 | 1 AMP | OFF | MOM. | .095 (2,41) TYP. with overtravel .042 (1,07) TYP. | 7.7 oz (220g) TYP. | N.O. with overtravel |
| | 8551 | 3 AMPS | | | | | |
| SPST  <p>Part number shown: 8531MZQE2</p> | | | | | | | |
| SP | 8532 | 1 AMP | OFF | MOM. | .050 (1,27) TYP. | 6 oz (170g) TYP. | N.O. |
| | 8552 | 3 AMPS | | | | | |
| SPST  <p>Part number shown: 8532MZQE2</p> | | | | | | | |
| SP | 8533 | 1 AMP | ON | MOM. | .080 (2,03) TYP. with pretravel .057 (1,45) TYP. | 11.5 oz (456 g) TYP. | N.C. with pretravel |
| | 8534 | 1 AMP | | | | | |
| SPST  <p>Part number shown: 8533MZQE2</p> | | | | | | | |

MOM. = Momentary

All models  with all options when ordered with G or Q contact material.

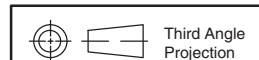

Dimensions are shown: Inches (mm)
Specifications and dimensions subject to change

www.ck-components.com



8500 Series Subminiature Pushbutton Switches

Pushbutton
A

PLUNGER

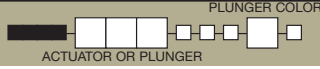

M .150" HIGH PLUNGER

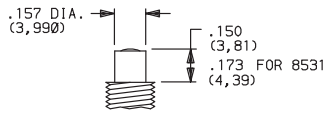

S .210" HIGH PLUNGER

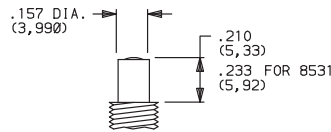

PANEL MOUNTING

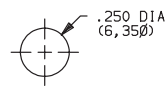

| OPTION CODE | PLUNGER COLOR |
|-------------|---------------|
| 2 | BLACK |
| 3 | RED |

NOTE: One mounting nut and lockwasher supplied with all actuators (except T actuator: two nuts supplied).

ACTUATOR

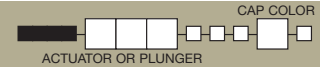

T 15/32 BUSHING

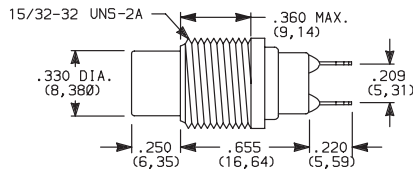

NOTE: No frame color choice required.

T1 15/32 BUSHING WITH FRAME

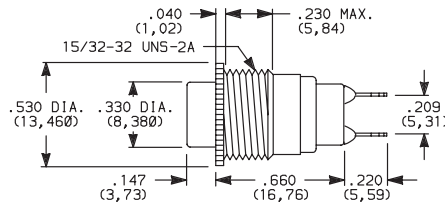

NOTE: No frame color choice required.
Available with 8532 and 8534 models only.

PANEL MOUNTING

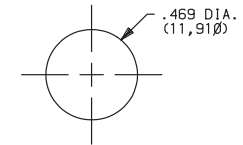

| OPTION CODE | CAP COLOR |
|-------------|-----------|
| 2 | BLACK |
| 1 | WHITE |
| 3 | RED |
| 9 | GRAY |

Cap Finish: gloss. Other colors available, consult Customer Service Center.

One mounting nut and lockwasher supplied with all actuators (except T actuator: two nuts supplied).

NOTE: Caps available for plunger options, see page A-65.

ACTUATOR—SNAP-IN FRONT MOUNT

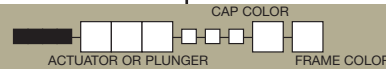

J81 SNAP-IN WITH FRAME

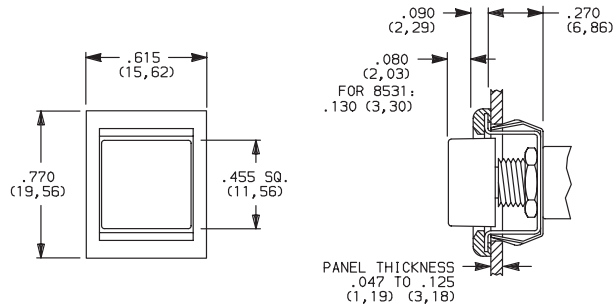

| OPTION CODE | CAP AND FRAME COLOR |
|-------------|---------------------|
| 2 | BLACK |

Cap and Frame Finish: matte. Other colors available, consult Customer Service Center.

One mounting nut and lockwasher supplied with all actuators.

NOTE: Caps & frames available separately, see pages A-65 and A-66.

PANEL MOUNTING

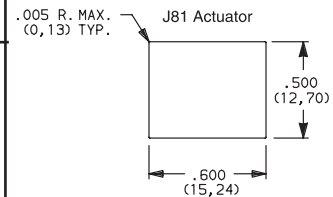

J82 SNAP-IN WITH FRAME FOR LED

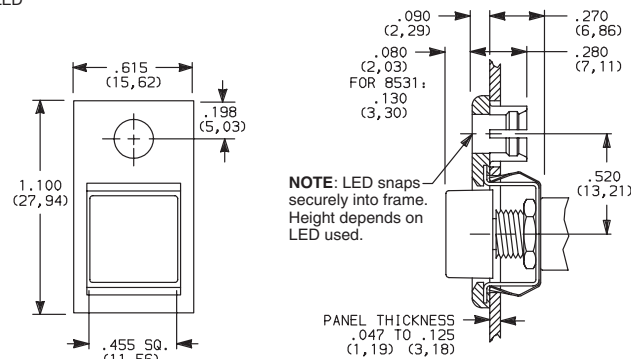

NOTE: LED snaps securely into frame. Height depends on LED used.

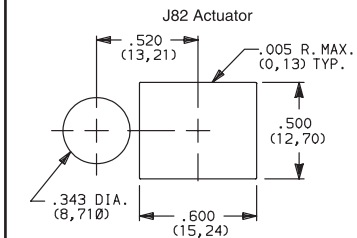

LED not included.
For LED information, see page A-66.



Dimensions are shown: Inches (mm)
Specifications and dimensions subject to change



8500 Series Subminiature Pushbutton Switches



A

Pushbutton

TERMINATIONS

Z SOLDER LUG

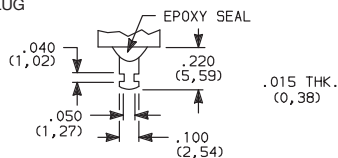

C PC THRU-HOLE

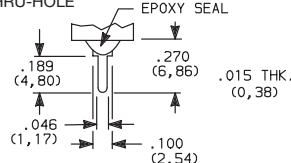

PC MOUNTING

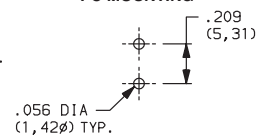

AV RIGHT ANGLE, PC THRU-HOLE

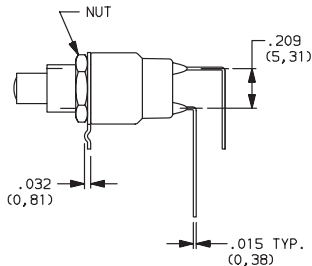
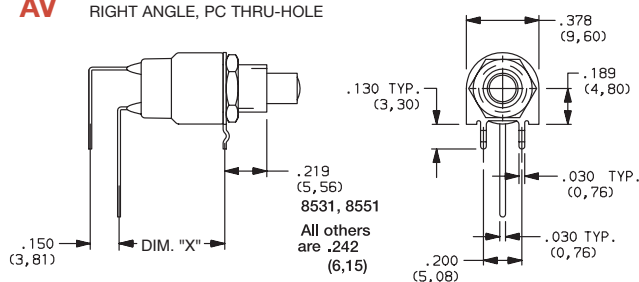

PC MOUNTING

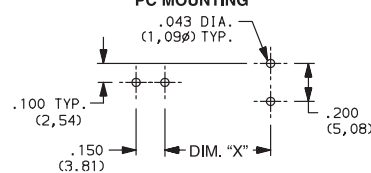

Available with

| MODEL NO. | DIM "X" |
|------------|---------|
| 8531, 8533 | 0.550 |
| 8532, 8534 | 0.438 |

NOTE: Available with M or S plunger models, and B contact material only.

CONTACT MATERIAL

| OPTION CODE | RoHS COMPLIANT * | RoHS COMPATIBLE * | TERMINAL PLATING | CONTACT MATERIAL | RATINGS | |
|-------------|------------------|-------------------|-------------------------------|---------------------|--------------------------------|--|
| B | YES | YES | GOLD ¹ | GOLD | LOW LEVEL/DRY CIRCUIT | 0.4 VA MAX. @ 20 V AC OR DC MAX. |
| Q | YES | YES | SILVER ⁴ | SILVER ⁵ | POWER | 853X MODELS: 1 AMP @ 120 V AC OR 28 V DC. 855X MODELS: 3 AMPS @ 120 V AC OR 28 V DC. |
| G | YES | YES | GOLD OVER SILVER ² | GOLD ³ | LOW LEVEL/DRY CIRCUIT OR POWER | 0.4 V MAX @ 20 V AC OR DC MAX. OR 853X MODELS: 1 AMP @ 120 V AC OR 28 V DC. 855X MODELS: 3 AMPS @ 120 V AC OR 28 V DC. |

* Note: See Technical Data section of this catalog for RoHS compliant and compatible definitions and specifications.

¹ CONTACTS & TERMINALS: Copper alloy, with gold plate over nickel plate.

² CONTACTS: Coin silver, with gold plate over nickel plate.

³ TERMINALS: Copper alloy, with gold plate over nickel plate.

⁴ CONTACTS: Coin silver, silver plated.

⁵ TERMINALS: Copper alloy, silver plated.

NOTE: Any models supplied with Q, B or G contact material are RoHS compliant.

All models with all options when ordered with G or Q contact material.

Q contact material standard with C, Z terminations.

8551 & 8552 available with Q contact material only.

SEAL

E EPOXY SEAL



REPLACEMENT HARDWARE

Cap for 0.157" dia. plungers

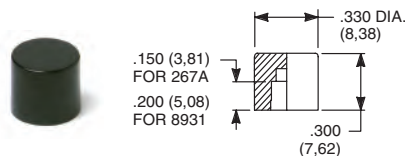

PART NO.

267A01000 WHITE
267A02000 BLACK
267A03000 RED
267A09000 GRAY

85X2T, 8534T models only
Material: Nylon
Finish: Gloss

PART NO.

893101000 WHITE
893102000 BLACK
893103000 RED
893109000 GRAY

85X1T, 8532T1, 8533T, 8534T1 models only
Material: Nylon
Finish: Gloss

Cap, J80, J81 & J 82 options only

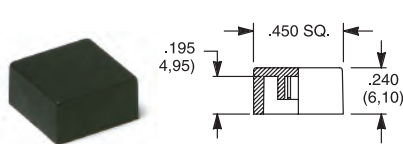

PART NO.

448901000 WHITE
448902000 BLACK
448903000 RED
448909000 GRAY

Material: Nylon
Finish: Gloss or matte

Other colors available, consult Customer Service Center.

Frame



PART NO.

613302263 BLACK

Material: Nylon
Finish: Matte



Third Angle Projection



Dimensions are shown: Inches (mm)
Specifications and dimensions subject to change



8500 Series Subminiature Pushbutton Switches

AVAILABLE HARDWARE

Pushbutton
A

Frame



PART NO.
615602263 BLACK
Material: Nylon
Finish: Matte

NOTE: Additional nuts, locking rings and lockwashers available separately, see section "Technical Data and Additional Hardware".
Other colors available, consult Customer Service Center.

Frames snap into panel opening and are independent from switch mounting. Accurate positioning of the PC mounted switch relative to the panel opening is necessary to provide proper clearance between actuator and frame. Available in two basic styles and four panel thicknesses .047-.125 in. Material: Nylon. Finish: Matte.

TYPICAL APPLICATION

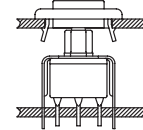

.047" (1,19) PANEL THK. .062" (1,57) PANEL THK. .090" (2,29) PANEL THK. .125" (3,18) PANEL THK.

| | | | |
|-------------------------------------|-------------------------------------|-------------------------------------|---|
| PART NO. 432502263 | PART NO. 432602263 | PART NO. 432702263 | PART NO. 432802263 BLACK |
|-------------------------------------|-------------------------------------|-------------------------------------|---|

PANEL MOUNTING

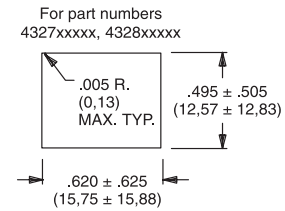
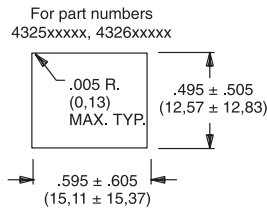

Panel Inserts

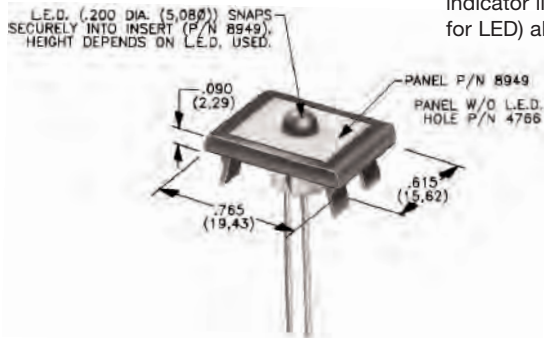

Above frames (part nos. 432XXXXXX) are also available with insert which accepts LED for indicator light assembly. Order insert separately from frame. Blank insert panel (without hole for LED) also available. **LED not included.**

PANEL INSERT WITH HOLE FOR LED

PART NO.
894902000

BLANK PANEL INSERT WITHOUT HOLE FOR LED

PART NO.
476602000 BLACK

Special colors, custom markings available, consult Customer Service Center.

LED INFORMATION

Process Information: Soldering to LED leads must be completed within 5 seconds at 500°F (260°C) maximum. LEDs are not supplied with J82 option. LED snaps into switch frame surrounding actuator and is wired externally.

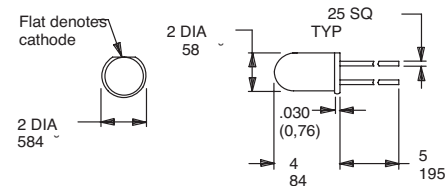

Suggested LED for J82 option
Dimensions for reference only



Dimensions are shown: Inches (mm)
Specifications and dimensions subject to change



KM Series Subminiature Pushbutton Switches



A
Pushbutton

Features/Benefits

- **Reliable contact design**
- **Available with pretravel and overtravel**
- **RoHS compliant**

Typical Applications

- **Alarm systems**
- **Computers**
- **Detector switch application**

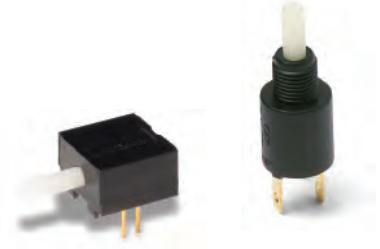

Models Available

Specifications

CONTACT RATING: Q contact material (KM11, KM12 Models): 0.25 AMPS @ 125 V AC or DC (UL); (KM33 Model): 1 AMP @ 125 V AC or 28 V DC. See page A-69 for additional ratings.

ELECTRICAL LIFE: 10,000 actuations min. at full load.

CONTACT RESISTANCE: Below 30 mΩ typ. initial @ 2-4 V DC, 100 mA, for both silver and gold plated contacts.

INSULATION RESISTANCE: 10⁹Ω min.

DIELECTRIC STRENGTH: 1,000 Vrms min. @ sea level.

OPERATING TEMPERATURE: -30°C to 85°C.

CAP INSTALLATION FORCE: 10 lbs. max. permissible.

NOTE: Any models supplied with Q or B contact material are RoHS compliant.

NOTE: Specifications and materials listed above are for switches with standard options. For information on specific and custom switches, consult Customer Service Center.

Materials

HOUSING & BUSHING: 6/6 nylon (UL94V-2), black.

ACTUATOR: 6/6 nylon (UL 94V-2), natural. Internal o-ring seal, available on KM11 & KM33 models.

MOVABLE CONTACT: B contact material: Bronze or copper, with gold plate over nickel plate. See page A-69 for additional contact materials.

STATIONARY CONTACTS & TERMINALS: B contact material: Copper, with gold plate over nickel plate. See page A-69 for additional contact materials.

RETURN SPRING: Music wire, phosphor coated.

MOUNTING NUT: Brass, nickel plated.

TERMINAL SEAL: Epoxy.

Build-A-Switch

To order, simply select desired option from each category and place in the appropriate box. Available options are shown and described on pages A-68 and A-70. For additional options not shown in catalog, consult Customer Service Center.

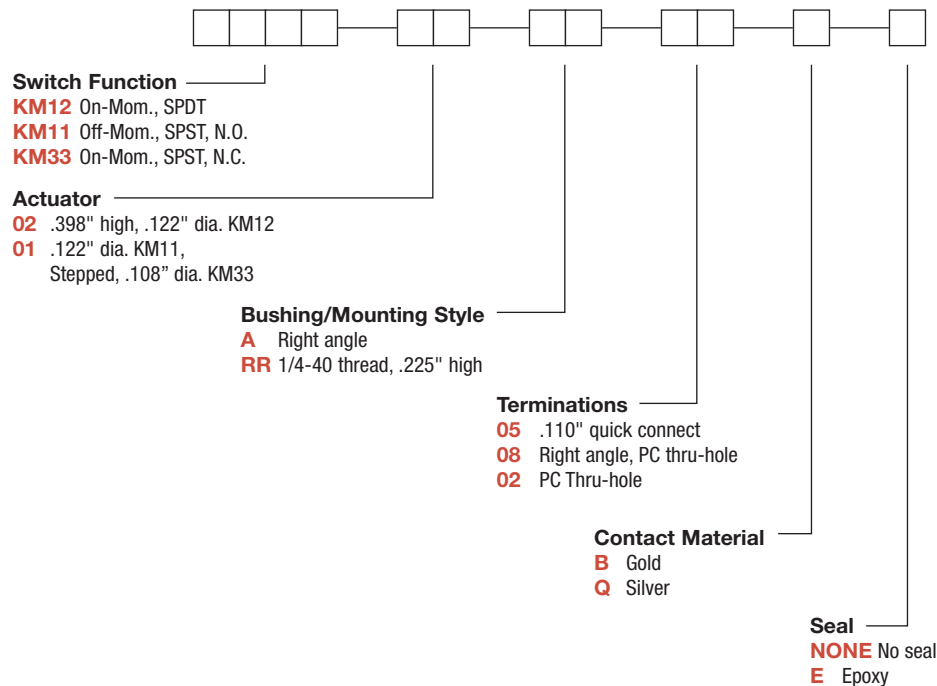

Dimensions are shown: Inches (mm)
Specifications and dimensions subject to change



KM Series Subminiature Pushbutton Switches

SWITCH FUNCTION

Pushbutton
A

| NO. POLES | MODEL NO. | SWITCH FUNCTION | | CONNECTED TERMINALS | | SCHEMATIC |
|-------------|-------------|-----------------|--------|---------------------|--------|-----------|
| | | POS. 1 | POS. 2 | POS. 1 | POS. 2 | |
| SP | KM11 | OFF | MOM. | OPEN | 2-1 | SPST N.O. |
| | KM33 | ON | MOM. | 2-1 | OPEN | SPST N.C. |
| SPST | | | | | | |
| SP | KM12 | ON | MOM. | 2-1 | 4-3 | SPDT |
| SPDT | | | | | | |

ACTUATOR

02 .398" HIGH, .122" DIA.

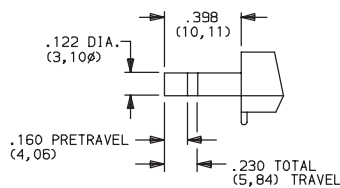

KM12 models only.

01 .122" DIA.

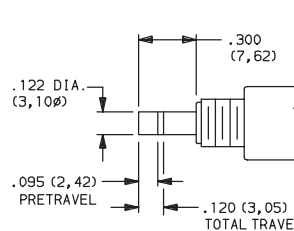

KM11 models only.

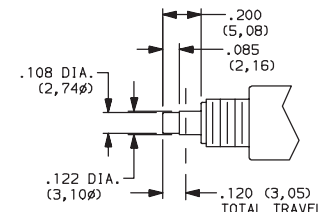

KM33 models only.

NOTE: Caps available for plunger options, see page A-70.

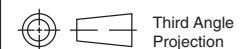

Dimensions are shown: Inches (mm)
Specifications and dimensions subject to change



KM Series Subminiature Pushbutton Switches



A

Pushbutton

BUSHING/ MOUNTING STYLE



A RIGHT ANGLE

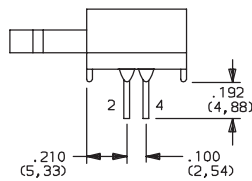

KM12 models only.

RR 1/4-40 THREAD, .225" HIGH

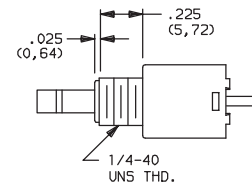

KM11 & KM33 models only.

PANEL MOUNTING



KM11 & KM33 models.

PC MOUNTING

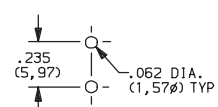

KM11 models only.

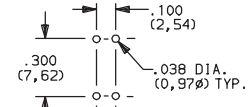

KM12 models only.

TERMINATIONS



05 .110" QUICK CONNECT

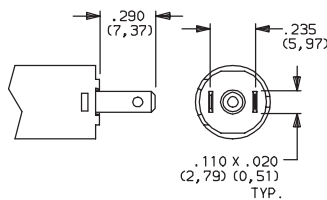

08 RIGHT ANGLE, PC THRU-HOLE

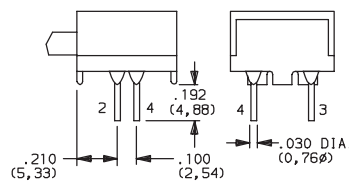

KM12 models only.

02 PC THRU-HOLE

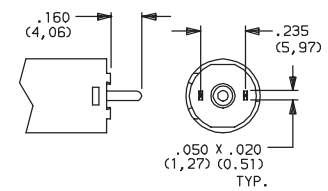

KM11 models only.

CONTACT MATERIAL



| OPTION CODE | RoHS COMPLIANT * | RoHS COMPATIBLE * | CONTACT AND TERMINAL MATERIAL | RATINGS | |
|-------------|------------------|-------------------|-------------------------------|-----------------------|---|
| | | | | | |
| B | YES | YES | GOLD ¹ | LOW LEVEL/DRY CIRCUIT | 0.4 VA MAX. @ 20 V AC OR DC MAX. |
| Q | YES | YES | SILVER ² | POWER | 0.25 AMPS @ 125 V AC OR DC (KM11, KM12) (UL) 1 AMP @ 125 V AC OR 28 V DC (KM33). |

* Note: See Technical Data section of this catalog for RoHS compliant and compatible definitions and specifications.

¹ STATIONARY CONTACTS & TERMINALS: Copper, with gold plate over nickel plate.
MOVABLE CONTACT: Phosphor bronze or beryllium copper, with gold plate over nickel plate.

² STATIONARY CONTACTS & TERMINALS: Copper, silver plated (standard with all termination options).
MOVABLE CONTACT: Phosphor bronze or beryllium copper, silver plated.

³ STATIONARY CONTACTS & TERMINALS: Copper, with gold plate over nickel plate over silver plate.
MOVABLE CONTACT: Phosphor bronze or beryllium copper, with gold plate over nickel plate over silver plate.

NOTE: Any models supplied with Q or B contact material are RoHS compliant.

KM11, KM12 models when ordered with 'Q' contact material.

SEAL



NONE NO SEAL

E EPOXY SEAL

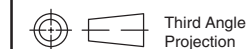
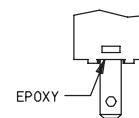

Third Angle
Projection

C&K

Dimensions are shown: Inches (mm)
Specifications and dimensions subject to change



KM Series Subminiature Pushbutton Switches

Pushbutton
A

AVAILABLE HARDWARE

Cap, KM33 models

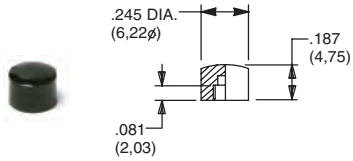

PART NO.
785101000 WHITE
785102000 BLACK
785103000 RED

Material: Nylon
 Finish: Gloss

Cap, KM11 and KM12 models

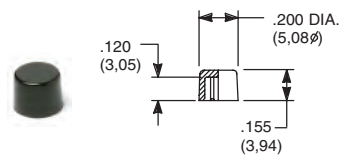

PART NO.
708901000 WHITE
708902000 BLACK
708903000 RED

Material: Nylon
 Finish: Gloss

Cap, KM11 and KM12 models

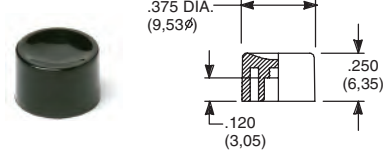

PART NO.
752701000 WHITE
752702000 BLACK
752703000 RED

Material: Nylon
 Finish: Gloss

Cap, KM11 and KM12 models

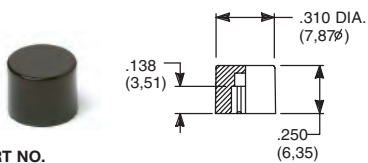

PART NO.
801801000 WHITE
801802000 BLACK
801803000 RED

Material: Nylon
 Finish: Gloss

Cap, KM11 models

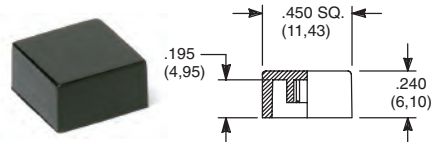

PART NO.
484601000 WHITE
484602000 BLACK
484603000 RED

PART NO.
798201000 WHITE
798202263 BLACK
798203000 RED

Material: Nylon
 Finish: Gloss

Material: Nylon
 Finish: Matte

NOTE: Other cap colors available, consult Customer Service Center.

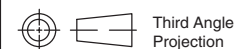

Dimensions are shown: Inches (mm)
 Specifications and dimensions subject to change

8600 Series Microminiature Pushbutton Switches



A
Pushbutton

Features/Benefits

- Available with overtravel
- Normally closed models available
- Microminiature size ideal for applications where space is limited
- RoHS compliant

Typical Applications

- Detection
- Telecommunications and networking equipment
- Computers and peripherals



Models Available

Specifications

CONTACT RATING: Q contact material (8631, 8632 Models):
500 mA @ 120 V AC or 28 V DC; 250 mA @ 250 V AC;
(8633 Model): 250 mA @ 120 V AC or 28 V DC; 125 mA
@ 250 V AC. See page A-73 for additional ratings.

ELECTRICAL LIFE:

8631 and 8633 MODELS: 250,000 actuations at full load.
8632 MODEL: 100,000 actuations at full load.

CONTACT RESISTANCE: Below 30 mΩ typ. initial @
2-4 V DC, 100 mA, for both silver and gold plated contacts.

INSULATION RESISTANCE: 109 Ω min.

DIELECTRIC STRENGTH: 500 Vrms min. @ sea level.

OPERATING TEMPERATURE: -30°C to 65°C.

SOLDERABILITY: Per MIL-STD-202F method 208D, or
EIA RS-186E method 9.

Materials

CASE: Glass filled phenolic or diallyl phthalate (DAP), (UL94V-0).

PLUNGER: Glass filled nylon (UL94V-0), black standard.

BUSHING: Brass, nickel plated.

CONTACTS: Q contact material: Coin silver, silver plated.
See page A-73 for additional contact materials.

TERMINALS:

8631, 8632 MODELS: Copper alloy, silver plated.

8633 MODEL: Q contact material: Coin silver.

See page A-73 for additional contact materials.

TERMINAL SEAL:

8633 MODEL: Epoxy.

8631, 8632 MODELS: Terminals insert molded.

HARDWARE: Nut: Brass, nickel plated.

NOTE: Any models supplied with Q, B or G contact material are RoHS compliant.

NOTE: Specifications and materials listed above are for switches with standard options.
For information on specific and custom switches, consult Customer Service Center.

Build-A-Switch

To order, simply select desired option from each category and place in the appropriate box. Available options are shown and described on pages A-72 and A-73. For additional options not shown in catalog, consult Customer Service Center.

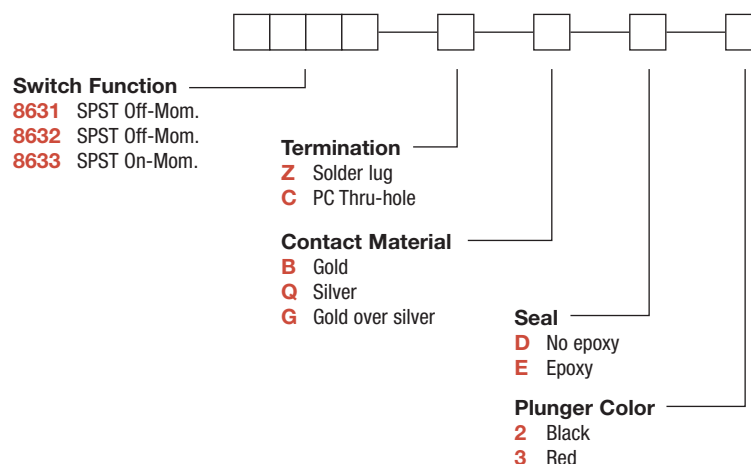

Dimensions are shown: Inches (mm)
Specifications and dimensions subject to change



8600 Series Microminiature Pushbutton Switches

Pushbutton
A

SWITCH FUNCTION

| NO. POLES | MODEL NO. | SWITCH FUNCTION | | TOTAL TRAVEL | ACTUATION FORCE | SCHEMATIC |
|---|-------------|-----------------|--------|---|---------------------|----------------------|
| | | POS. 1 | POS. 2 | | | |
| SP | 8631 | OFF | MOM. | .040 (1,02) TYP. | 5 oz (140g) TYP. | N.O. |
| SPST <p>Part number shown: 8631ZQD2</p> <p>Terminals Insert Molded</p> | | | | | | |
| SP | 8632 | OFF | MOM. | .106 (2,69) TYP. with overtravel .024 (0,61) TYP. | 6.25 oz (177g) TYP. | N.O. with overtravel |
| SPST <p>Part number shown: 8632ZQD2</p> <p>Terminals Insert Molded</p> | | | | | | |
| SP | 8633 | ON | MOM. | .048 (1,22) TYP. | 5 oz (140g) TYP. | N.C. |
| SPST <p>Part number shown: 8633ZQE2</p> | | | | | | |

MOM. = Momentary

NOTE: Caps available for plunger options, see page A-73.

TERMINATIONS

Z SOLDER LUG

C PC THRU-HOLE

8631, 8632 models only.

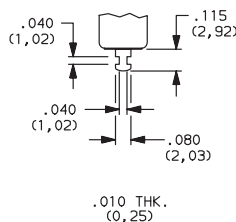

8633 models only.

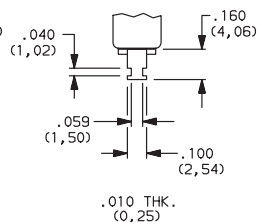

8631, 8632 models only.

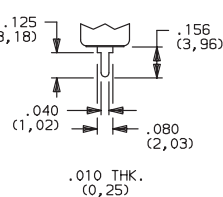

PC MOUNTING

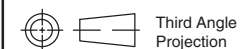
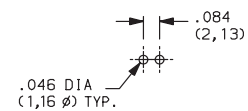

Dimensions are shown: Inches (mm)
Specifications and dimensions subject to change



8600 Series Microminiature Pushbutton Switches



A
Pushbutton

CONTACT MATERIAL

| OPTION CODE | RoHS COMPLIANT * | RoHS COMPATIBLE * | CONTACT MATERIAL | TERMINAL PLATING | RATINGS | |
|-------------|------------------|-------------------|--------------------|------------------|--------------------------------|--|
| | | | | | | |
| B | YES | YES | GOLD 1 | GOLD 1 | LOW LEVEL/ DRY CIRCUIT | 0.4 VA MAX. @ 20 V AC OR DC MAX. |
| Q | YES | YES | SILVER 4 | SILVER 5 | POWER | 8631, 8632 MODELS: 500 mA @ 120 V AC OR 28 V DC; 250 mA @ 250 V AC. 8633 MODELS: 250 mA @ 120 V AC OR 28 V DC; 125 mA @ 250 V AC. |
| G | YES | YES | GOLD OVER SILVER 4 | GOLD 3 | LOW LEVEL/DRY CIRCUIT OR POWER | 0.4 VA MAX @ 20 V AC OR DC MAX. OR 8631, 8632 MODELS: 500 mA @ 120 V AC OR 28 V DC; 250 mA @ 250 V AC. 8633 MODELS: 250 mA @ 120 V AC OR 28 V DC; 125 mA @ 250 V AC. |

* Note: See Technical Data section of this catalog for RoHS compliant and compatible definitions and specifications.

- 1 CONTACTS & TERMINALS: Copper alloy, with gold plate over nickel plate.
- 2 CONTACTS: Coin silver, with gold plate over nickel plate.
- 3 TERMINALS: Copper alloy, with gold plate over nickel plate.
8633 model only: Coin silver, with gold plate over nickel plate.
- 4 CONTACTS: Coin silver, silver plated.
- 5 TERMINALS: Copper alloy, silver plated. 8633 model only: coin silver.

NOTE: Any models supplied with Q, B or G contact material are RoHS compliant.

8631, 8632 models with all options when ordered with G or Q contact material. Q contact material standard with C, Z terminations.

SEAL

D NO EPOXY SEAL

E EPOXY SEAL

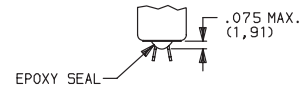

Not available on 8633 model.
Standard on 8631, 8632 models.

Not available on 8631, 8632 models.
Standard on 8633 model only.

PLUNGER COLOR

| OPTION CODE | COLOR |
|-------------|-------|
| 2 | BLACK |
| 3 | RED |

AVAILABLE HARDWARE

Cap

PART NO.

785101000 WHITE
785102000 BLACK
785103000 RED

Material: Nylon
Finish: Gloss

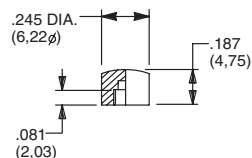

NOTE: Other cap colors available, consult Customer Service Center.



Dimensions are shown: Inches (mm)
Specifications and dimensions subject to change

C&K



A

Pushbutton

8700 Series Overtravel Pushbutton Switches



Features/Benefits

- **Extended pre-travel or over-travel**
- **Heavy-duty brass plunger**
- **Long electrical life – 100K cycles**
- **RoHS compliant**

Typical Applications

- **Telecommunications**
- **High end Instrumentation**
- **Medical & test equipment**
- **Detection**

Specifications

CONTACT RATING: Q contact material: 1 AMP @ 120 V AC or 28 V DC. See page A-76 for additional ratings.
 ELECTRICAL LIFE: 100,000 actuations at full load.
 CONTACT RESISTANCE: Below 30 mΩ typ. Initial @ 2-4 V DC, 100 mA.
 INSULATION RESISTANCE: 10³Ω min.
 DIELECTRIC STRENGTH: 1,000 Vrms min. @ sea level.
 OPERATING TEMPERATURE: -30°C to 65°C.

NOTE: Any models supplied with Q, or B contact material are RoHS compliant.

NOTE: Specifications and materials listed above are for switches with standard options. For information on specific and custom switches, consult Customer Service Center.

Materials

CASE: Diallyl phthalate (DAP) (UL 94V-0).
 PLUNGER:
 8731 – .390" brass, nickel plated.
 8732 – .390" PBT polyester, black.
 BUSHING: brass, nickel plated.
 CONTACTS: Q contact material: Coin silver, silver plated. See page A-76 for additional contact materials.
 TERMINALS: Q contact material: Copper alloy, silver plated. See page A-76 for additional contact materials.
 TERMINAL SEAL: Epoxy.
 HARDWARE: Nut: Brass, nickel plated; lockwasher: Steel, bright nickel plate. One mounting nut & lockwasher supplied with all switches.

Build-A-Switch

To order, simply select desired option from each category and place in the appropriate box. Available options are shown and described on pages A-75 and A-76. For additional options not shown in catalog, consult Customer Service Center. All models have epoxy terminal seal and are compatible with all "bottom-wash" PCB cleaning methods.

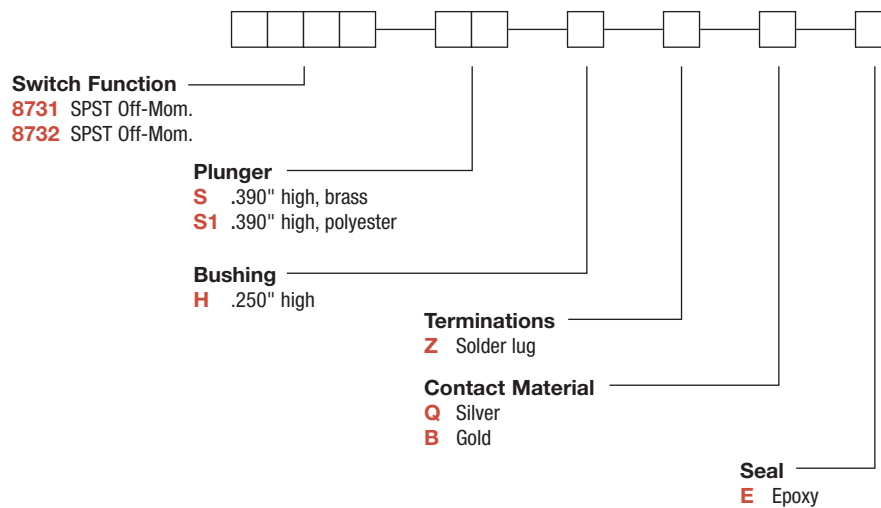

Dimensions are shown: Inches (mm)
 Specifications and dimensions subject to change

8700 Series Overtravel Pushbutton Switches



A

Pushbutton

SWITCH FUNCTION

| NO. POLES | MODEL NO. | SWITCH FUNCTION | | TOTAL TRAVEL | ACTUATION FORCE | SCHEMATIC |
|--|-------------|-----------------|--------|--|-----------------|---------------------------|
| | | POS. 1 | POS. 2 | | | |
| SP | 8731 | OFF | MOM. | .390 (9,91) TYP. with overtravel .311 TYP. | 4.7 oz TYP. | N.O. with overtravel SPST |
| SPST <p>Part number shown: 8731SHZQE</p> | | | | | | |
| SP | 8732 | OFF | MOM. | .390 (9,91) TYP. with overtravel .350 TYP. | 2.2 oz TYP. | N.O. with overtravel SPST |
| SPST <p>Part number shown: 8732S1HZQE</p> | | | | | | |

MOM. = Momentary

PLUNGER

S .390" HIGH, BRASS

S1 .390" HIGH, PBT POLYESTER

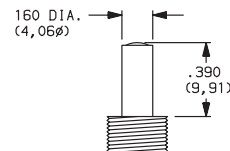
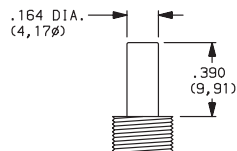

Available with 8731 model only.

Available with 8732 model only.

BUSHING

H .250" HIGH

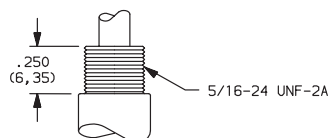

PANEL MOUNTING

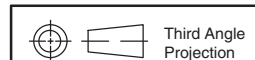
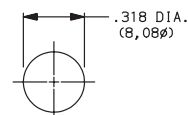

Third Angle Projection



Dimensions are shown: Inches (mm)
Specifications and dimensions subject to change

www.ck-components.com



8700 Series Overtravel Pushbutton Switches

A

Pushbutton

TERMINATIONS

Z SOLDER LUG

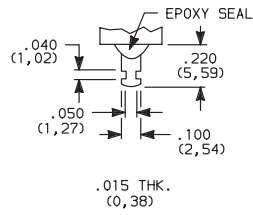

CONTACT MATERIAL

| OPTION CODE | RoHS COMPLIANT * | RoHS COMPATIBLE * | CONTACT MATERIAL | TERMINAL PLATING | RATINGS | |
|-------------|------------------|-------------------|------------------|------------------|-----------------------|----------------------------------|
| | | | | | POWER | |
| Q | YES | YES | SILVER | SILVER | | 1 AMP @ 125 V AC OR 28 V DC. |
| B | YES | YES | GOLD | GOLD | LOW LEVEL/DRY CIRCUIT | 0.4 VA MAX. @ 20 V AC OR DC MAX. |

* Note: See Technical Data section of this catalog for RoHS compliant and compatible definition and specifications.

NOTE: Any models supplied with Q, or B contact material are RoHS compliant.

SEAL

E EPOXY SEAL

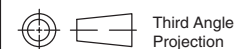
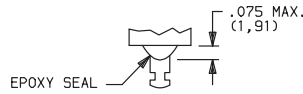

Dimensions are shown: Inches (mm)
Specifications and dimensions subject to change

GP Series Sealed Ultraminiature Pushbutton Switches



A
Pushbutton

Features/Benefits

- Ultraminiature design saves space
- Process compatible, withstands most soldering and washing processes
- Thru-hole and surface mount models available
- Sealed construction—internal o-ring and epoxy base
- RoHS compliant

Typical Applications

- Telecommunications and network equipment
- Computers and peripheral products
- Instrumentation
- Medical Applications

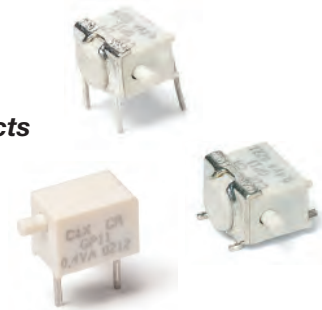

Specifications

CONTACT RATING: 0.4 VA max. @ 20 V AC or DC max.

MECHANICAL & ELECTRICAL LIFE: 40,000 make-and-break cycles at full load.

CONTACT RESISTANCE: Below 50 mΩ typ. initial @ 2-4 V DC, 100 mA.

INSULATION RESISTANCE: $10^9 \Omega$ min.

DIELECTRIC STRENGTH: 500 Vrms min. @ sea level.

OPERATING TEMPERATURE: -40°C to 85°C.

SOLDERABILITY: Per MIL-STD-202F method 208D, or EIA RS-186E method 9 (1 hour steam aging).

DEGREE OF PROTECTION: IP57; Protection against harmful dust deposit, full-scale voltage protection, temporary immersion.

PACKAGING: Surface mount switches standard in anti-static tape and reel packaging per EIA 481-3, see page A-80 for drawings and reel information. Thru-Hole parts are shipped in trays.

All models are RoHS compliant and compliant.

Materials

HOUSING & BASE: Glass filled nylon 4/6, flame retardant, heat stabilized (UL 94V-0).

ACTUATOR: Glass filled nylon 4/6, flame retardant (UL 94V-0) with standard internal o-ring seal.

SWITCH SUPPORT: Brass, tin plated.

MOVABLE CONTACT: Copper alloy, with gold plate over nickel plate.

STATIONARY CONTACTS Copper alloy, with gold plate over nickel plate.

TERMINALS: Copper alloy, with gold flash over nickel plate.

TERMINAL SEAL: Epoxy/Urethane. All terminals insert molded.

NOTE: Any models supplied with B contact material are RoHS compliant and compatible.

NOTE: Materials listed above are general specifications. Specifications available for specific and custom switches, consult Customer Service Center.

CAUTION: PC mounting layouts and pads as shown are designed to be compatible with the latest equipment and reflow techniques. Care should be taken in the design and location of PC lands to suit individual needs. Orientation relative to reflow direction may significantly impact solder joint integrity.

How To Order

Complete part numbers for GP Series Sealed Ultraminiature Pushbutton Switches are shown on pages A-78 thru A-80.

| PART NUMBER | SWITCH FUNCTION | | SCHEMATIC |
|-----------------|-----------------|--------|-----------|
| | POS.1 | POS. 2 | |
| GP11MCBE | OFF | MOM. | |
| Conn. Terms. | OPEN | 1-3 | SPST |
| GP12MCBE | ON | MOM. | |
| Conn. Terms. | 2-1 | 2-3 | SPDT |

MOM. = Momentary

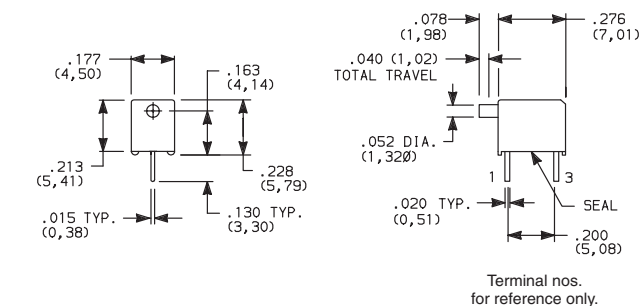

GP11MCBE
SPST

PC MOUNTING



GP11—omit center hole.

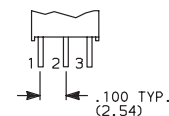

GP12 Model



Dimensions are shown: Inches (mm)
Specifications and dimensions subject to change



GP Series Sealed Ultraminiature Pushbutton Switches

A

Pushbutton



GP11MABE
SPST

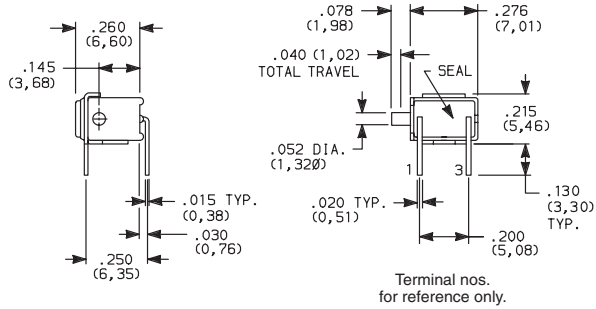

PC MOUNTING

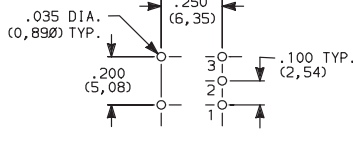

GP11- omit hole 2.

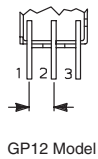

GP12 Model

| PART NUMBER | SWITCH FUNCTION | | SCHEMATIC |
|-----------------|-----------------|--------|-----------|
| | POS.1 | POS. 2 | |
| GP11MABE | OFF | MOM. | SPST |
| Conn. Terms. | OPEN | 1-3 | |
| GP12MABE | ON | MOM. | SPDT |
| Conn. Terms. | 2-1 | 2-3 | |

MOM. = Momentary



GP11MSABE
SPST

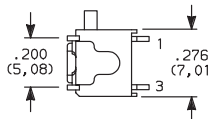
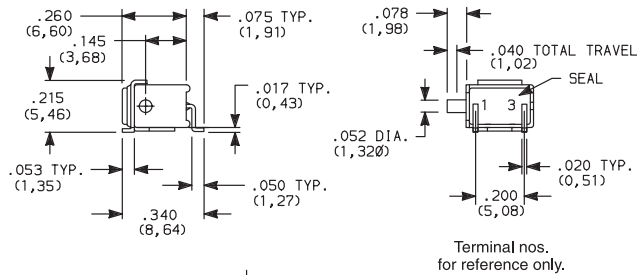

GP12 Model

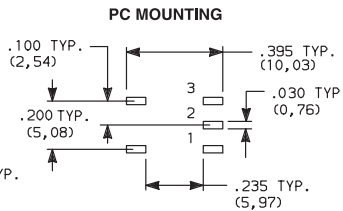

GP11- omit pad 2.

| PART NUMBER | SWITCH FUNCTION | | SCHEMATIC |
|------------------|-----------------|--------|-----------|
| | POS.1 | POS. 2 | |
| GP11MSABE | OFF | MOM. | SPST |
| Conn. Terms. | OPEN | 1-3 | |
| GP12MSABE | ON | MOM. | SPDT |
| Conn. Terms. | 2-1 | 2-3 | |

MOM. = Momentary



GP11MSA1BE
SPST

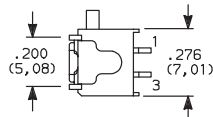
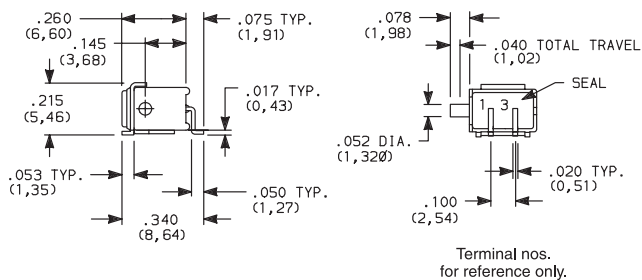

GP12 Model

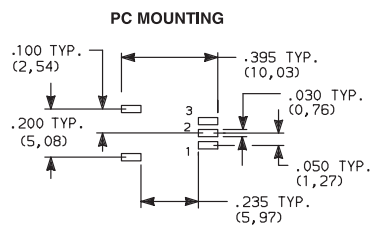

GP11- omit pad 2.

| PART NUMBER | SWITCH FUNCTION | | SCHEMATIC |
|-------------------|-----------------|--------|-----------|
| | POS.1 | POS. 2 | |
| GP11MSA1BE | OFF | MOM. | SPST |
| Conn. Terms. | OPEN | 1-3 | |
| GP12MSA1BE | ON | MOM. | SPDT |
| Conn. Terms. | 2-1 | 2-3 | |

MOM. = Momentary



Dimensions are shown: Inches (mm)
Specifications and dimensions subject to change



GP Series Sealed Ultraminiature Pushbutton Switches



A

Pushbutton

| PART NUMBER | SWITCH FUNCTION | | SCHEMATIC |
|------------------|-----------------|--------|----------------------------|
| | POS. 1 | POS. 2 | |
| GP12MSCBE | ON | MOM. | NC 1 2 (COMM) 3 NO |
| Conn. Terms. | 2-1 | 2-3 | |
| SPDT | | | |

MOM. = Momentary

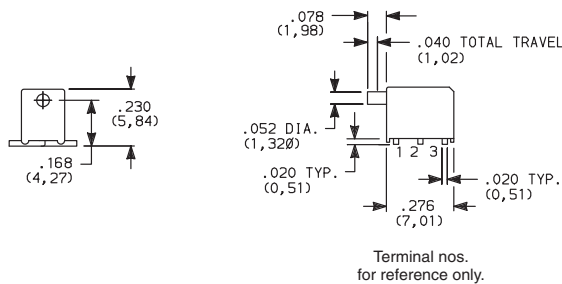

**GP12MSCBE
SPDT**

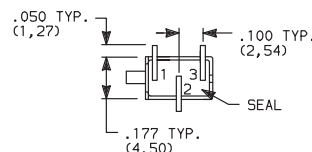
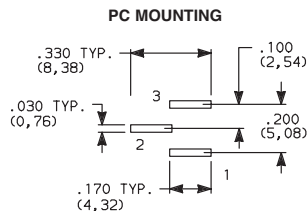

NOTE: Recommended for infrequent use applications only
For increased switch mounting strength, order, SV1 termination style with support bracket (see below).

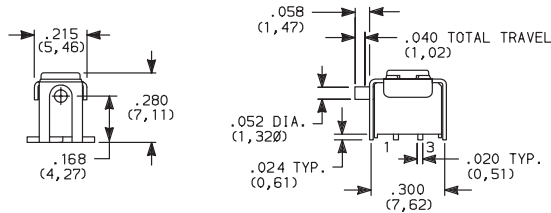

**GP11MSV1BE
SPST**

| PART NUMBER | SWITCH FUNCTION | | SCHEMATIC |
|-------------------|-----------------|--------|----------------------------|
| | POS. 1 | POS. 2 | |
| GP11MSV1BE | OFF | MOM. | 1 3 |
| Conn. Terms. | OPEN | 1-3 | |
| SPST | | | |
| GP12MSV1BE | ON | MOM. | NC 1 2 (COMM) 3 NO |
| Conn. Terms. | 2-1 | 2-3 | |
| SPDT | | | |

MOM. = Momentary

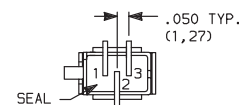
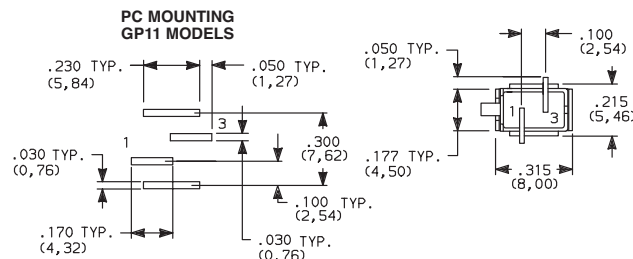

GP12 Model

Terminal nos.
for reference only.

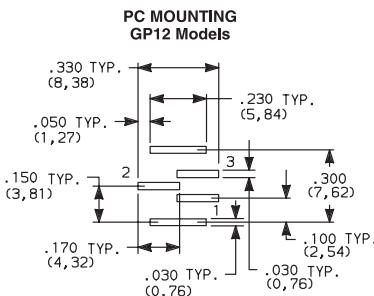

Third Angle
Projection

Dimensions are shown: Inches (mm)
Specifications and dimensions subject to change



www.ck-components.com



GP Series Sealed Ultraminiature Pushbutton Switches

TAPE & REEL

Pushbutton
A

For part numbers GP11MSV1BE, GP12MSV1BE

| REEL INFORMATION | |
|-------------------|---------------|
| OUTSIDE DIAMETER | 13.00 (330,0) |
| PILOT HOLE | .512 (13,0) |
| QUANTITY PER REEL | 600 |

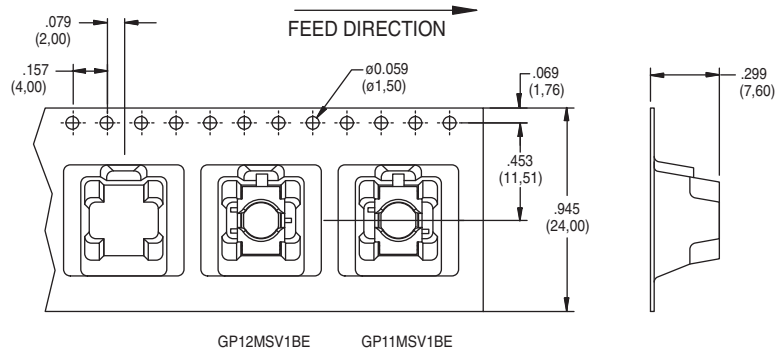

For part numbers GPXXSA1BE, GPXXMSABE

| REEL INFORMATION | |
|-------------------|---------------|
| OUTSIDE DIAMETER | 13.00 (330,0) |
| PILOT HOLE | .512 (13,0) |
| QUANTITY PER REEL | 600 |

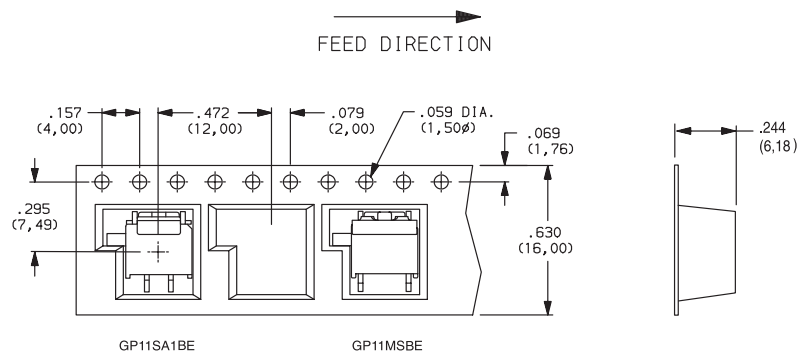

For part numbers GP12MSCBE

| REEL INFORMATION | |
|-------------------|---------------|
| OUTSIDE DIAMETER | 13.00 (330,0) |
| PILOT HOLE | .512 (13,0) |
| QUANTITY PER REEL | 600 |

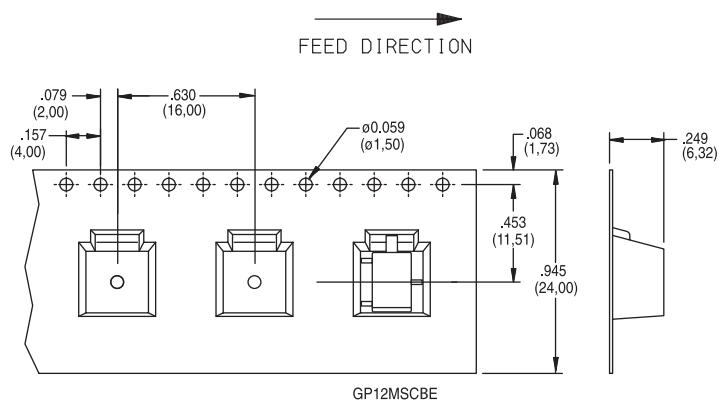

Dimensions are shown: Inches (mm)
Specifications and dimensions subject to change



PN Series Alternate & Momentary Action Pushbutton Switches



A

Pushbutton

Features/Benefits

- **Momentary or locking action**
- **Different actuation forces for customized feel**
- **Low cost, reliable contact design**
- **Single and double pole options**
- **RoHS compliant**

Typical Applications

- **Computers and peripherals**
- **Instrumentation and measurement equipment**
- **Non-power, on-off switch applications**



Specifications

CONTACT RATING: 0.2 AMP @ 30 V DC max.
 ELECTRICAL LIFE: 10,000 make-and-break cycles at full load.
 MECHANICAL LIFE: 10,000 on/off cycles.
 CONTACT RESISTANCE: 30 mΩ max. initial
 INSULATION RESISTANCE: 100 MΩ min.
 DIELECTRIC STRENGTH: 500 V AC min.
 OPERATING/STORAGE TEMPERATURES: -10°C to 60°C.
 PACKAGING: Switches are supplied in anti-static trays.

Materials

FRAME: Tin plated steel.
 ACTUATOR: PA 66 black.
 BASE: Phenolic resin.
 TERMINALS: Silver plated brass.
 MOVABLE CONTACTS: Silver plated phosphor bronze.
 RETURN SPRING: SWC
 DETENT SPRING: Phosphor bronze.
 DETENT SPRING PLATE: Phosphor bronze.
 RETURN SPRING RETAINER RING: Nickel plated steel.
 TERMINAL SEAL: Epoxy.

Build-A-Switch

To order, simply select desired option from each category and place in the appropriate box. For additional options not shown in catalog, consult Customer Service Center.

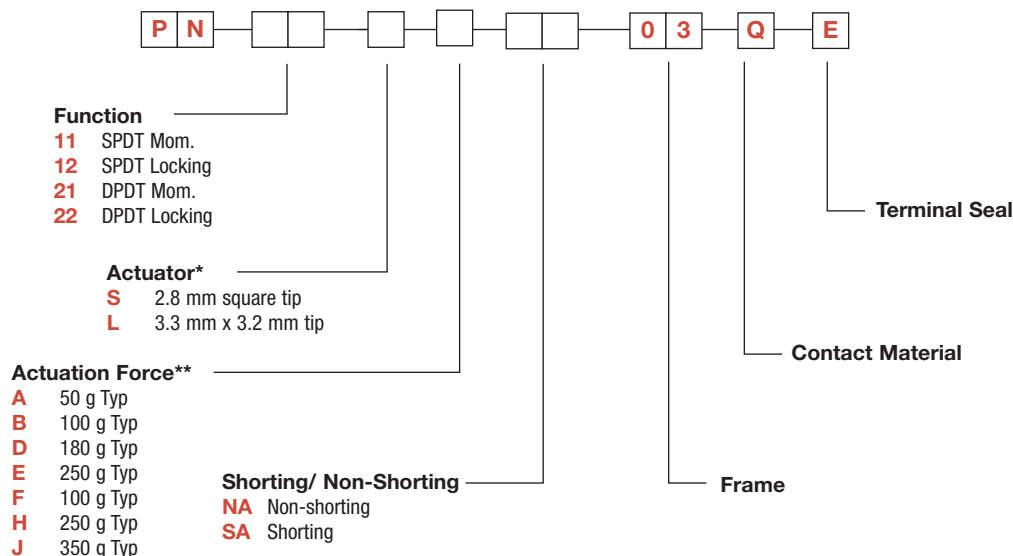

* Note - The switch body style dimensions differ for each of these 3 groupings

"S" actuator available for PN 11 & PN 12 options

"S" actuator available for PN 21 & PN 22 options

"L" actuator available for PN 21 & PN 22 options

** Actuation Force "A" only available with PN11 with "S" actuator

PN 11 & PN 21 available with Actuation Force "B", "D", "E", "F", "H", "J"

PN 12 & PN 22 available with Actuation Force "D", "E", "H", "J"

Full travel



Specifications and dimensions subject to change



PN Series Alternate & Momentary Action Pushbutton Switches

Pushbutton
A

PN 11 SPDT Mom.
PN 12 SPDT Locking

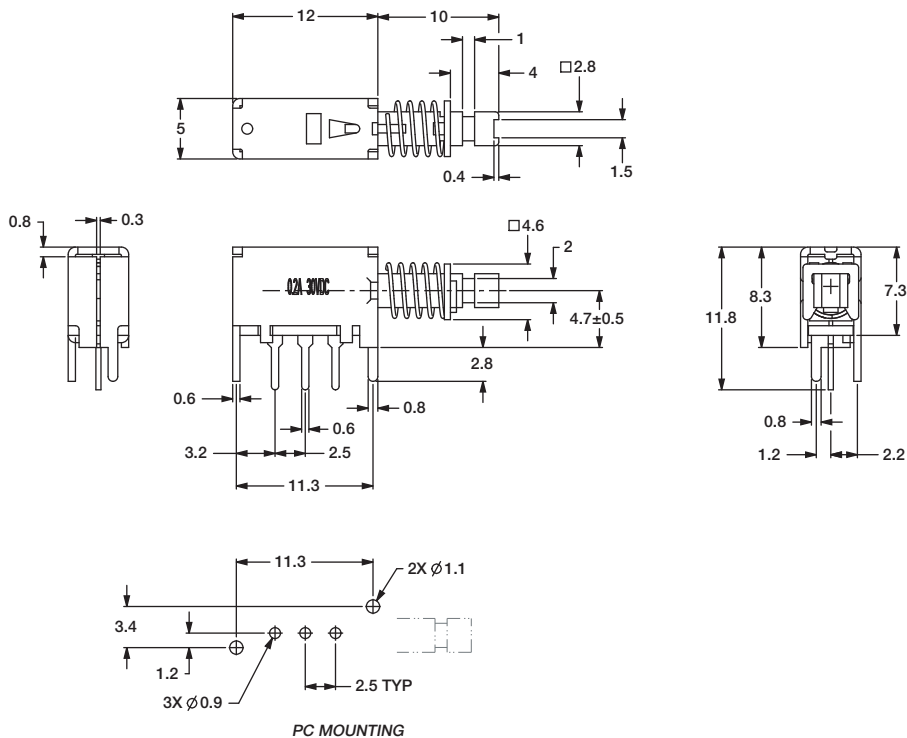

PN 21 DPDT Mom. with "S" Actuator
PN 22 DPDT Locking with "S" Actuator

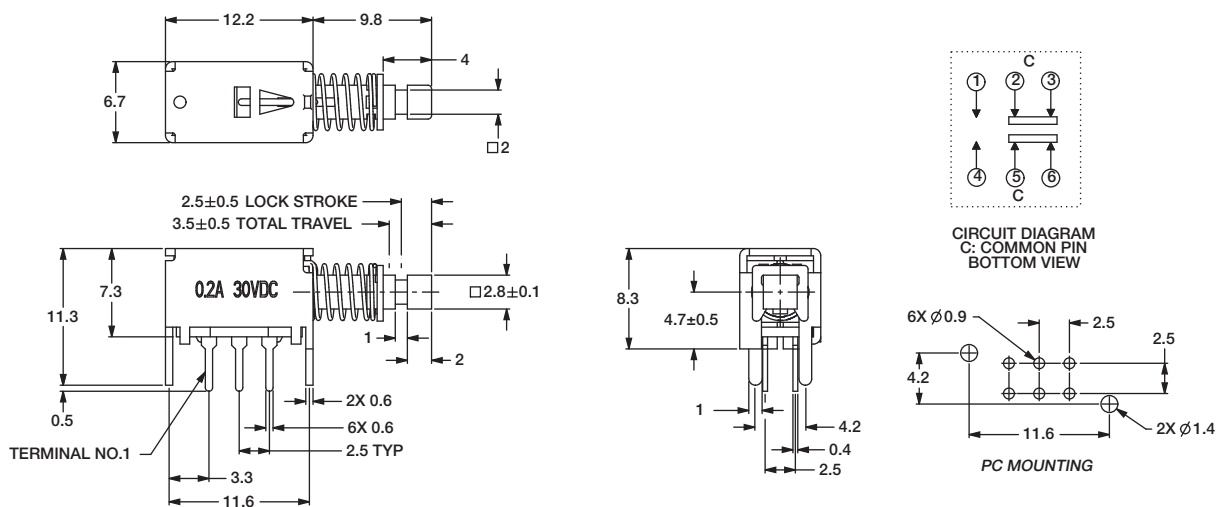

Dimensions are shown: mm
Specifications and dimensions subject to change



PN Series Alternate & Momentary Action Pushbutton Switches



A

Pushbutton

PN 21 DPDT Mom. with "L" Actuator
PN 22 DPDT Locking with "L" Actuator

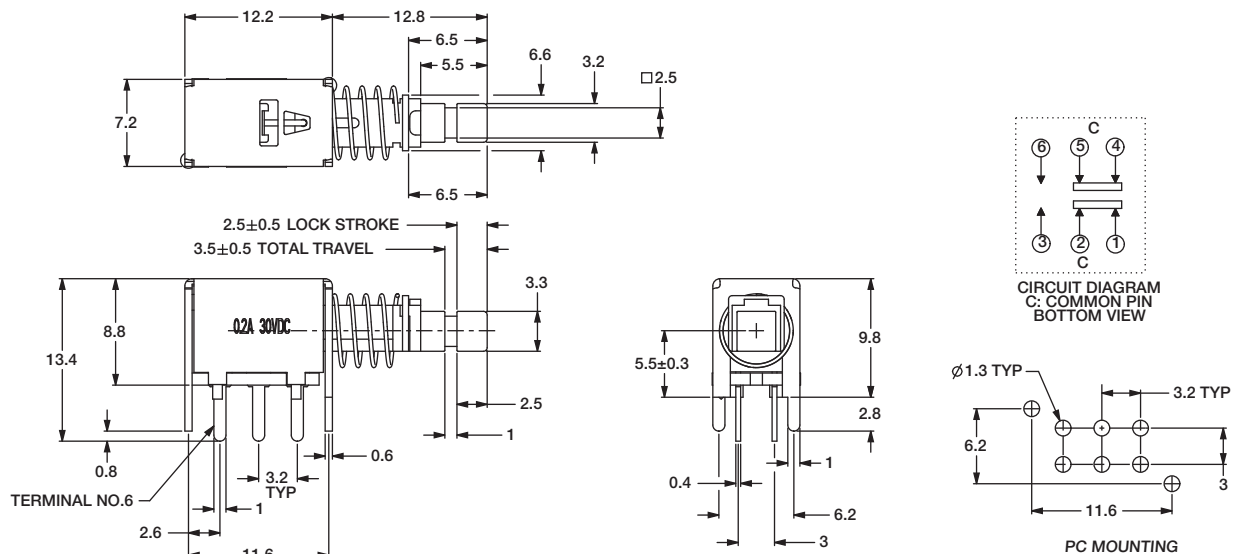

BUTTONS MUST BE ORDERED SEPARATELY. SHIPPED IN BULK.

PE

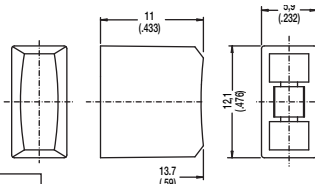
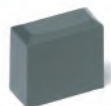

| OPTION CODE | COLOR |
|-------------|-------|
| RD | Red |
| GY | Gray |
| BK | Black |
| WH | White |

PE and PV buttons fit "L" actuators

PV

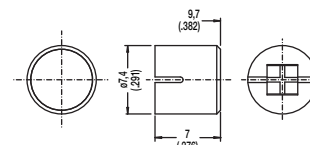

Indexed

G001A Black
G001G Gray
G001I Ivory
G001R Red

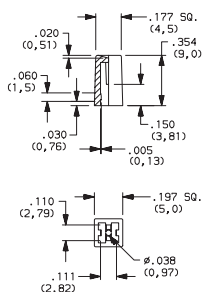

Rectangular

G002A Black
G002G Gray
G002I Ivory
G002R Red

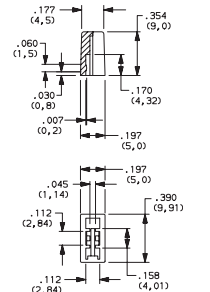

Round

G003A Black
G003G Gray
G003I Ivory
G003R Red

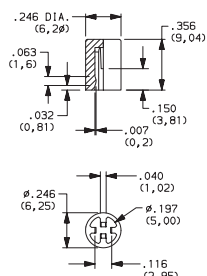

Square

G004A Black
G004G Gray
G004I Ivory
G004R Red

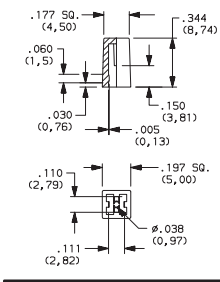
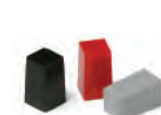

G001, G002, G003 and G004 buttons fit "S" actuators



Third Angle Projection



Dimensions are shown: Inches (mm)
 Specifications and dimensions subject to change

www.ck-components.com



PHB Series Short Stroke Pushbutton Switches

A

Pushbutton



Features/Benefits

- Momentary or latching action
- Low cost, reliable contact design
- 2 & 4 pole configurations
- Sealed contacts
- Optional buttons
- RoHS compliant

Typical Applications

- Computers and peripherals
- Instrumentation and measurement equipment
- Non-power, on-off switch applications

Specifications

RATING: 1 A @ 15 V DC
 DIELECTRIC STRENGTH (50 Hz/1 min.): 500 V DC between terminals or between terminals and frame for 1 minute
 OPERATING LIFE: 10,000 cycles at rated load
 CONTACT RESISTANCE: 20 m Ω ohms initial
 INSULATION RESISTANCE: 100 M Ω ohms
 TOTAL TRAVEL/LATCHING TRAVEL: 2.5mm (\pm 0.5 mm) / 1.5mm (\pm 0.5 mm) to latch EE option (push-push)
 OPERATING FORCE:
 2U option: 170 grams \pm 100 grams (1.67 \pm 0.98N)
 4U option: 230 grams \pm 100 grams (2.26 \pm 0.98N)
 OPERATING TEMPERATURE: -10°C to 60°C
 BOUNCE TIME: \leq 10 ms
 SEALING: Sealed contacts.
 PACKAGING: Switches; PHB2 models: 84 pcs per tray; PHB4 models 72 pcs per tray
 Optional Caps; Bulk bag - 100 caps per bag

Materials

FIXED TERMINAL: Brass, silver plated
 MOVABLE CONTACT: Phosphor bronze, silver plated
 COVER: PA 66 Black
 COVER TO BASE RETAINING CLIP: POM
 ACTUATOR: POM
 RETURN SPRING: Stainless steel
 SPRING RETAINING RING: Steel, nickel plate
 BASE: Phenolic resin
 TERMINAL SEAL: Epoxy.

NOTE: Specifications and materials listed above are for switches with standard options. For information on specific and custom switches, consult Customer Service Center.

Build-A-Switch

To order, simply select desired option from each category and place in the appropriate box. For additional options not shown in catalog, consult Customer Service Center.

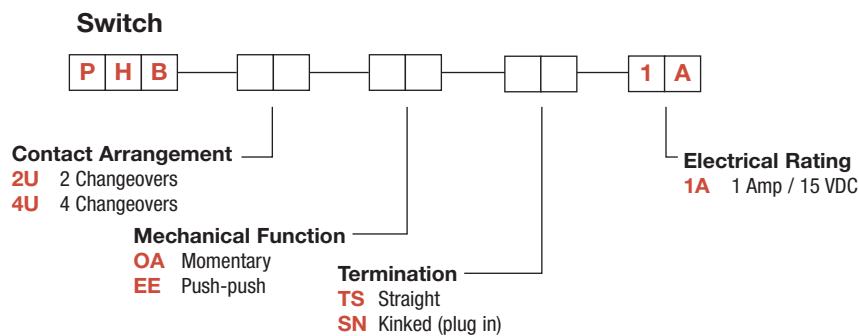

Caps (order separately)



| INDEXED | COLOR | RECTANGULAR | COLOR | ROUND | COLOR | SQUARE | COLOR |
|---------|-------|-------------|-------|-------|-------|--------|-------|
| G001A | BLACK | G002A | BLACK | G003A | BLACK | G004A | BLACK |
| G001G | GRAY | G002G | GRAY | G003G | GRAY | G004G | GRAY |
| G001I | IVORY | G002I | IVORY | G003I | IVORY | G004I | IVORY |
| G001R | RED | G002R | RED | G003R | RED | G004R | RED |



Dimensions are shown: Inches (mm)
 Specifications and dimensions subject to change

PHB Series Short Stroke Pushbutton Switches



A

Pushbutton

TERMINATION

TS STRAIGHT

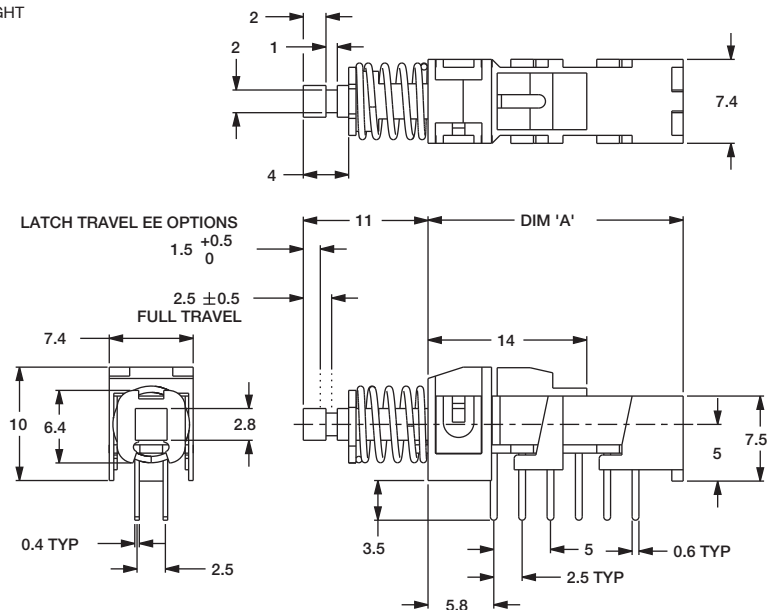

SN KINKED (PLUG IN)

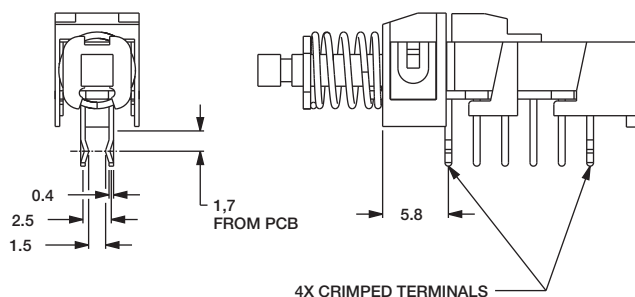

| POLES | MODEL NO. | DIM 'A' | ACTION |
|-------|-----------|---------|-----------|
| 4 | PHB4UEE1A | 22,5 | PUSH/PUSH |
| | PHB4U0A1A | 22,5 | MOMENTARY |
| 2 | PHB2UEE1A | 15,0 | PUSH/PUSH |
| | PHB2U0A1A | 15,0 | MOMENTARY |

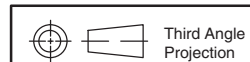
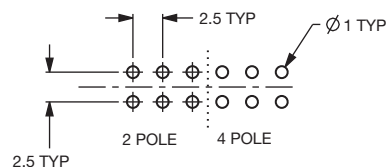
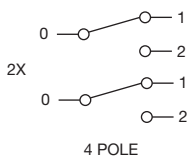
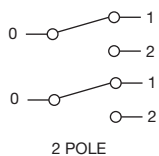

Dimensions are shown: mm
Specifications and dimensions subject to change



PHB Series Short Stroke Pushbutton Switches

CAPS

Pushbutton
A

Indexed

- G001A** Black
- G001G** Gray
- G001I** Ivory
- G001R** Red

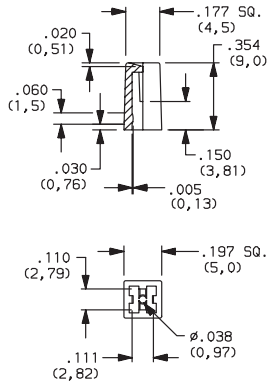

Rectangular

- G002A** Black
- G002G** Gray
- G002I** Ivory
- G002R** Red

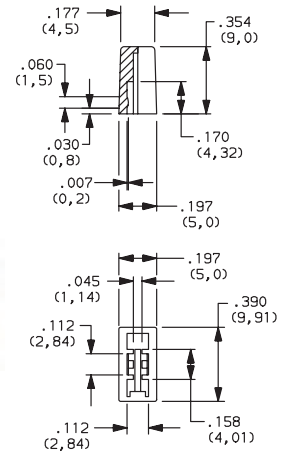

Round

- G003A** Black
- G003G** Gray
- G003I** Ivory
- G003R** Red

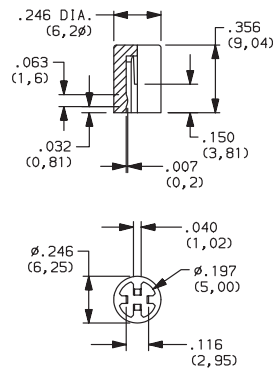

Square

- G004A** Black
- G004G** Gray
- G004I** Ivory
- G004R** Red

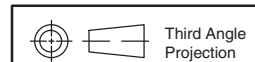
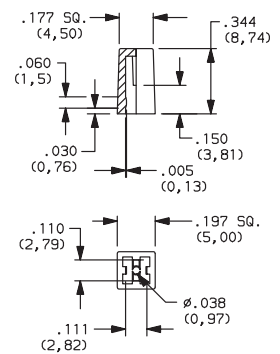
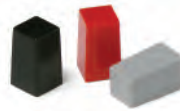

Dimensions are shown: Inches (mm)
Specifications and dimensions subject to change

F Series Pushbutton Switches



Features/Benefits

- Up to 10 poles per module
- Various contact terminals
- Various mounting & switch ganging configurations
- Mechanical indicator buttons
- RoHS compliant

Typical Applications

- Audio selection
- Digital equipment interface
- Medical equipment interface



Specifications

SWITCHING POWER: F module max. AC/DC: Silver: 50 VA/15W, Gold: 1 VA/300 mW.

SWITCHING VOLTAGE: F module max. AC/DC: Silver: 125/30V, Gold: 50/30 V.

SWITCHING CURRENT: F module max. AC/DC: Silver: 0.5A/0.5A, Gold: 0.04A/0.01A.

CARRYING CURRENT: Max at du = 20C: Silver: < 2A, Gold: <0.5A.

DIELECTRIC STRENGTH (50 Hz, 1 min.): Chassis/contact: \wedge 1500V Between contacts: \wedge 1500V.

OPERATING LIFE "O/A/E" (24V/200mA): $>10^5$ operations "GR": $>3.5 \times 10^4$ operations.

CONTACT RESISTANCE: Initial: Typical %10 m Ω , max. 20 m Ω After operating life: %100 m Ω

INSULATION RESISTANCE: $\wedge 10^9 \Omega$ between open contacts, $\wedge 10^9 \Omega$ between chassis and contacts.

CAPACITANCE (at f = 10 kHz): %0.7 pF between 2 contacts.

TOTAL TRAVEL/LATCHING TRAVEL: 4.7mm/3.3mm (.185 inch/.130 inch).

All models and options are RoHS compliant and compatible.

NOTE: All models and options are RoHS compliant and compatible.

NOTE: Specifications and materials listed above are for switches with standard options. For information on specific and custom switches, consult Customer Service Center.

TYPICAL F OPERATING FORCE: 2U: 6.5N (650 grams); 4U: 6.5N (650 grams); 6U: 7.5N (750 grams); 8U: 9.0N (900 grams); 10U: 9.0N (900 grams).

EUROPEAN TYPICAL SF OPERATING FORCE:
2U: 3.5N \pm 0.5N (350 grams \pm 100 grams); 4U: 5N \pm 1N (500 grams \pm 100 grams); 6U: 6.5N \pm 1N (650 grams \pm 100 grams); 8U: 9.0N \pm 1N (900 grams \pm 100 grams).

OPERATING TEMPERATURE RANGE: -40°C to 70°C.

Materials

HOUSING: Polycarbonate UL 94V-0 or polyester UL 94V-0.

ACTUATOR: Polyester UL 94V-0.

MOVABLE CONTACTS: Bimetal brass, silver plated, gold plate over nickel.

STATIONARY CONTACTS & TERMINALS: Brass, silver plated, gold plated.

TERMINAL BOARD: Polyester UL 94V-0.

RETURN SPRING: Music wire.

TERMINAL SEAL: RTV adhesive sealant.

CHASSIS: Steel.

LOCKOUT PIN: Steel.

BLOCKERS: Steel.

Build-A-Switch

To order, simply select desired option from each category and place in the appropriate box. Available options are shown and described on pages A-88 thru A-95. For additional options not shown in catalog, consult Customer Service Center.

If requesting only a switch, select either a North American or European switch as noted below. Chassis and buttons are sold separately. If multiple stations are selected, we will assume all switches are the same unless noted otherwise.

North American Order Code - Switch Only

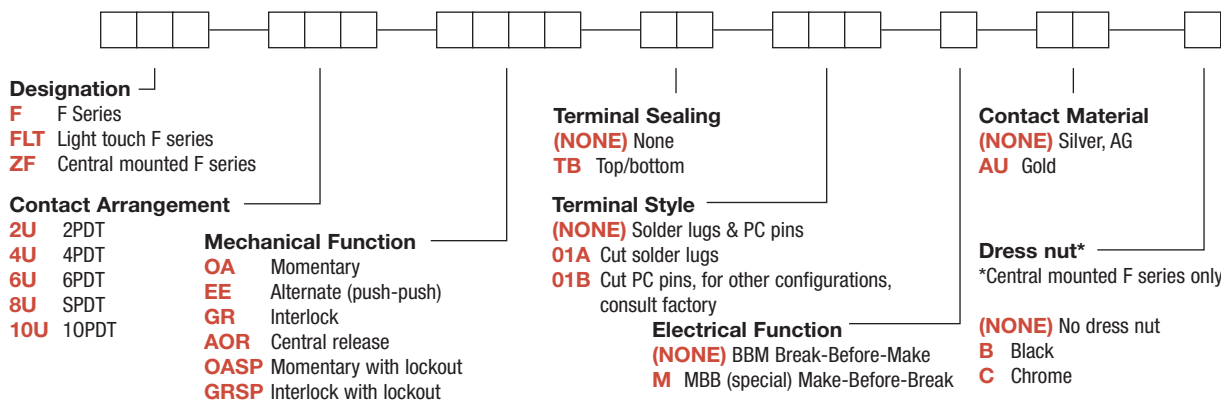

Dimensions are shown: Inches (mm)
Specifications and dimensions subject to change



F Series Pushbutton Switches

Pushbutton
A

European Order Code - Switch Only

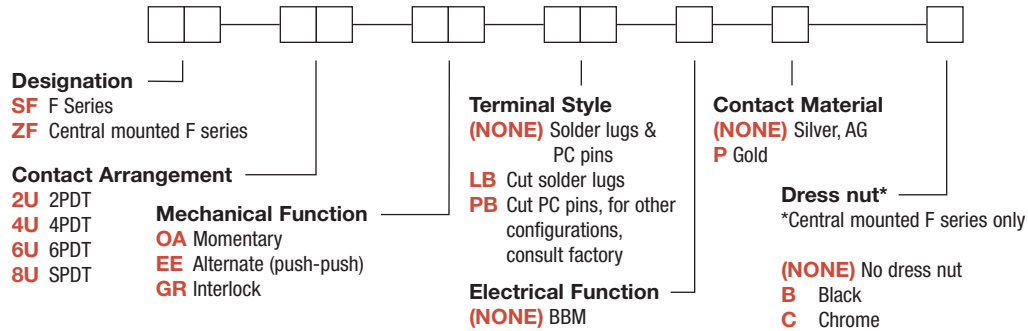

*Minimum order quantities apply.

Order Code - Buttons

Solid Buttons

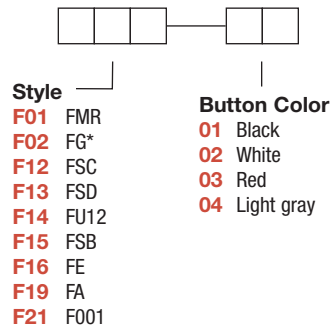

Mechanical Indicator Buttons

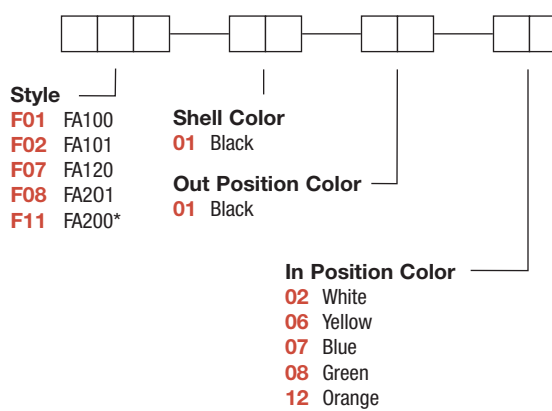

*Button options for central mounting configurations, use 'FG' for central mount with chrome dress nut, use 'FA200' for central mount with black dress nut.

BUTTON REMOVAL

A button of a push-push switch should only be removed in the "OFF" non-latching position.

Order Code - Chassis

To order a switch with chassis, create the switch part number listed above and add the Chassis part number configurator information at the end of the part number.

Note: We do not guarantee or recommend interlocking beyond 10 stations.

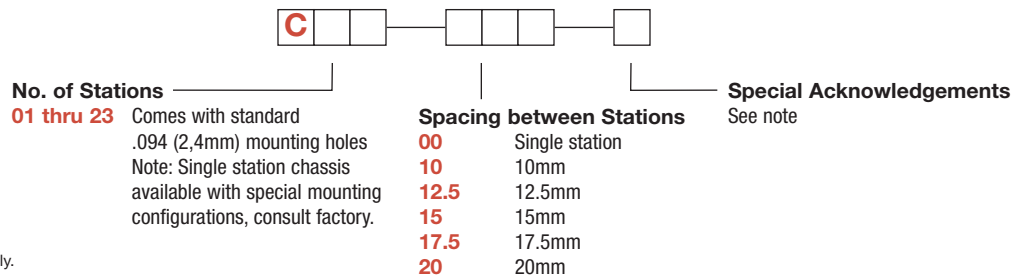

*Minimum order quantities apply.



Dimensions are shown: Inches (mm)
 Specifications and dimensions subject to change

F Series Pushbutton Switches



A

Pushbutton

SWITCHES WITH STANDARD OPTIONS

F2UEE

| CONTACT ARRANGEMENT | LENGTH DIM 'L' |
|---------------------|----------------|
| 2U | 0.827 (21,00) |
| 4U | 1.300 (33,00) |
| 6U | 1.770 (45,00) |
| 8U | 2.240 (57,00) |
| 10U | 2.720 (69,00) |

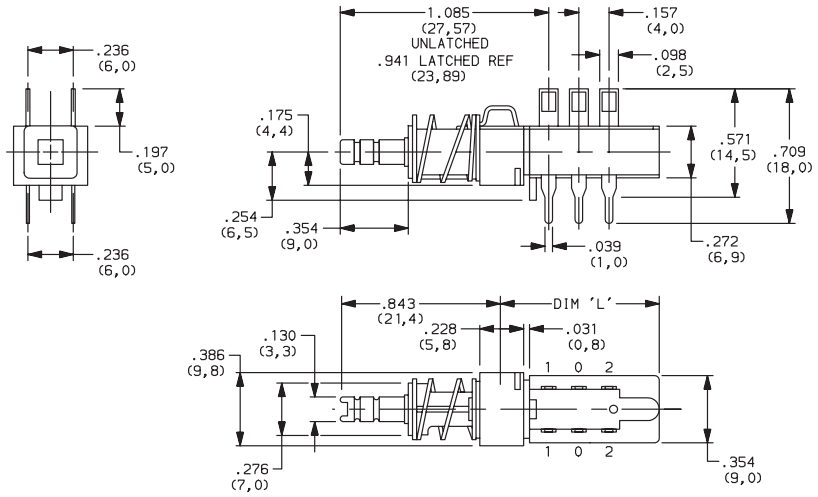

ZF2UEEBF11010108

| CONTACT ARRANGEMENT | LENGTH DIM 'L' |
|---------------------|----------------|
| 2U | 0.827 (21,00) |
| 4U | 1.300 (33,00) |
| 6U | 1.770 (45,00) |
| 8U | 2.240 (57,00) |
| 10U | 2.720 (69,00) |

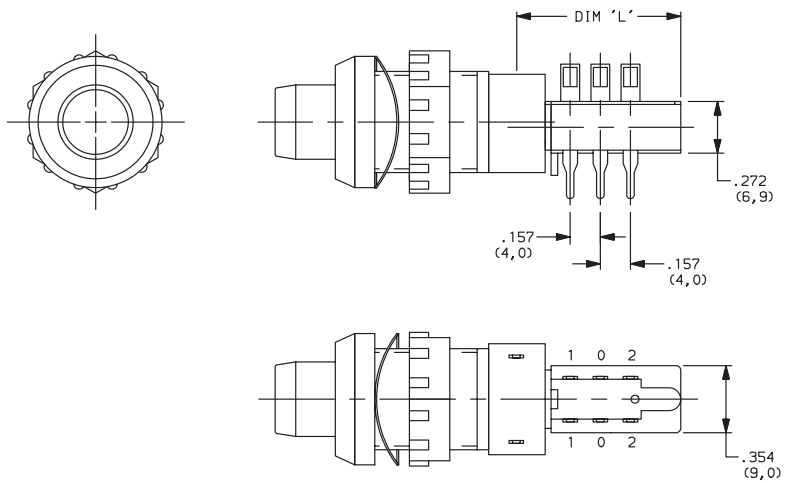

DESIGNATION



Designation, North America

- F** F Series
- FLT** Light touch F series
- ZF** Central mounted F series

Designation, Europe

- SF** F Series
- ZF** Central mounted F series

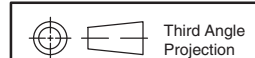

Dimensions are shown: Inches (mm)
Specifications and dimensions subject to change

www.ck-components.com



F Series Pushbutton Switches

A

Pushbutton

CONTACT ARRANGEMENT



| OPTION CODE | NO. OF POLES | SCHEMATIC |
|-------------|--------------|-----------|
| 2U | 2PDT | |
| 4U | 4PDT | 2X |
| 6U | 6PDT | 3X |
| 8U | 8PDT | 4X |
| 10U | 10PDT | 5X |

PC MOUNTING

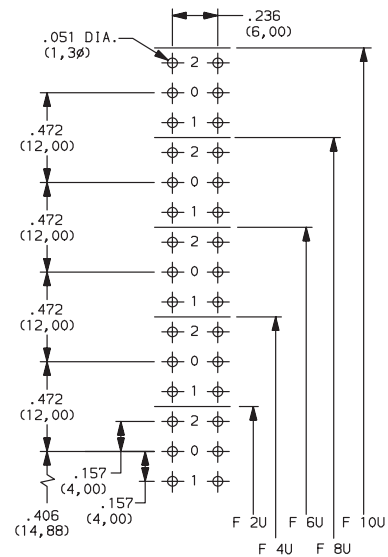

MECHANICAL FUNCTION



North America

| OPTION CODE | FUNCTION |
|-------------|------------------------|
| OA | Momentary |
| EE | Alternate (push-push) |
| GR | Interlock |
| AOR | Central release |
| OASP | Momentary with lockout |
| GRSP | Interlock with lockout |

Europe

| OPTION CODE | FUNCTION |
|-------------|-----------------------|
| OA | Momentary |
| EE | Alternate (push-push) |
| GR | Interlock |

TERMINAL SEALING



(NONE) NO SEAL

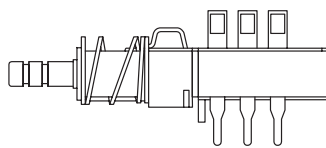

F2UEE shown in example above.

TB TOP & BOTTOM

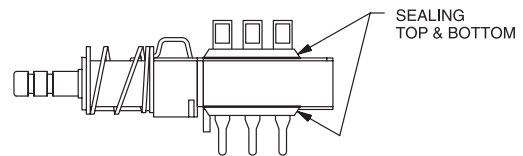

NOTE: Available for North America only



Dimensions are shown: Inches (mm)
Specifications and dimensions subject to change

F Series Pushbutton Switches



A
Pushbutton

TERMINAL STYLE



(NONE) SOLDER LUGS & PC PINS

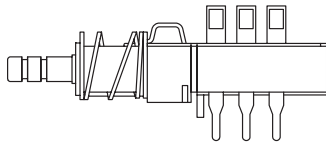

01A CUT SOLDER LUGS (North America)

LB CUT SOLDER LUGS (Europe)

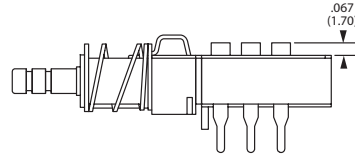

01B CUT PC PINS (North America)

PB CUT PC PINS (Europe)

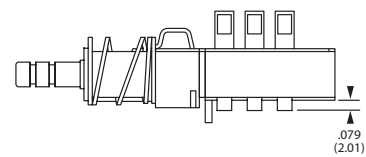

ELECTRICAL FUNCTION



| OPTION CODE | FUNCTION |
|---------------|-----------------------------------|
| (NONE) | BBM Non-shorting |
| M | MBB Shorting (North America only) |

CONTACT MATERIAL



| NORTH AMERICA OPTION CODE | EUROPE OPTION CODE | RoHS COMPLIANT * | RoHS COMPATIBLE * | MATERIAL | RATING |
|---------------------------|--------------------|------------------|-------------------|------------|------------------------------------|
| (NONE) | (NONE) | YES | YES | SILVER, AG | 50 VA/15 W; 125/30 V; 0.5/0.5 A |
| AU | P | YES | YES | GOLD | 1 VA/300mW; 50/30 V; 0.04 A/0.01 A |

* Note: See Technical Data section of this catalog for RoHS compliant and compatible definitions and specifications.

DRESS NUT



(NONE) NO DRESS NUT FOR F & F/LT DESIGNATIONS

B BLACK

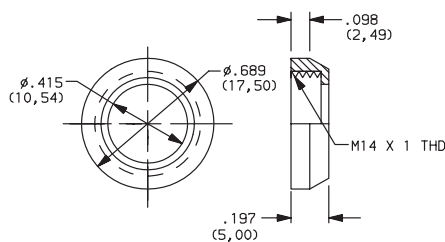

PANEL CUTOUT

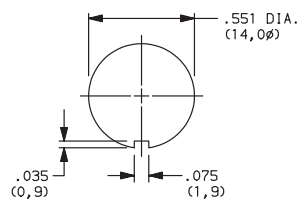

NOTE: Available with ZF designation and FA200 buttons.

C CHROME

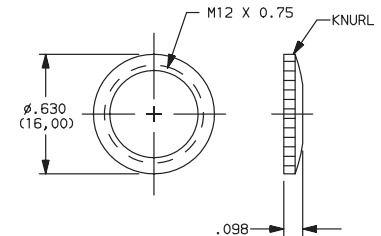

PANEL CUTOUT

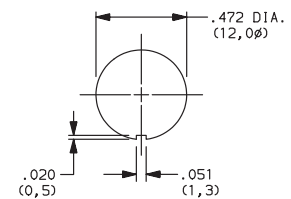

NOTE: Available with ZF designation and FG button.

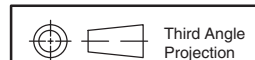

Third Angle Projection

Dimensions are shown: Inches (mm)
Specifications and dimensions subject to change





F Series Pushbutton Switches

SOLID BUTTON



Pushbutton
A

STYLE

F01 FMR

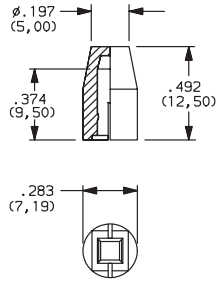

F02 FG

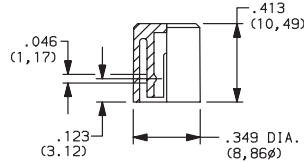

F12 FSC

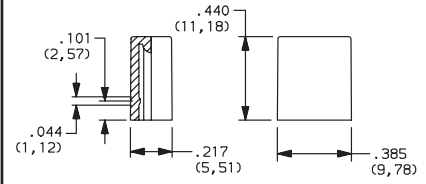
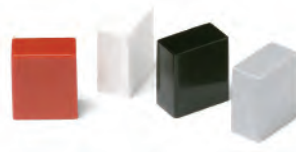

F13 FSD

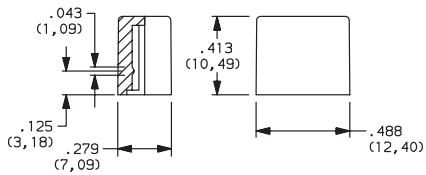
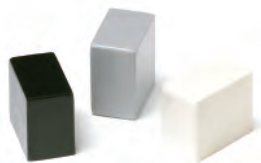

F14 FU12

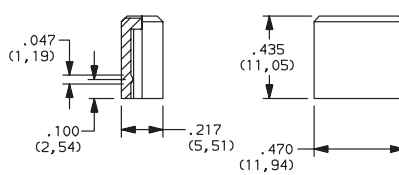
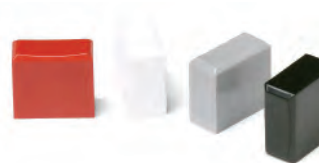

F15 FSB

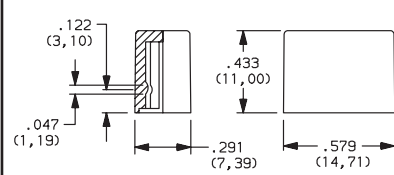

F16 FE

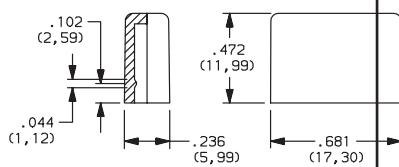

F19 FA

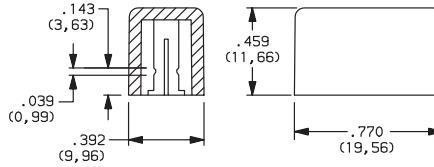

F21 F001

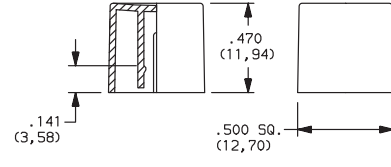

| OPTION CODE | COLOR |
|-------------|----------|
| 01 | BLACK |
| 02 | WHITE |
| 03 | RED |
| 04 | LT. GRAY |



Dimensions are shown: Inches (mm)
Specifications and dimensions subject to change

F Series Pushbutton Switches



A

Pushbutton

MECHANICAL BUTTON

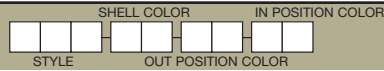

STYLE

F01 FA100

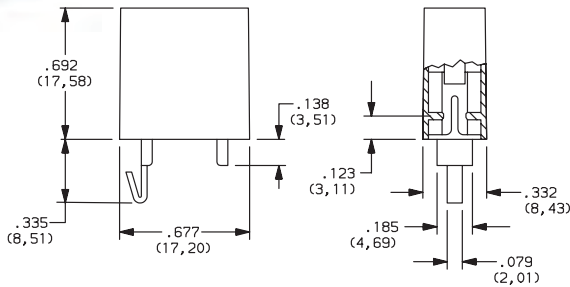

F02 FA101

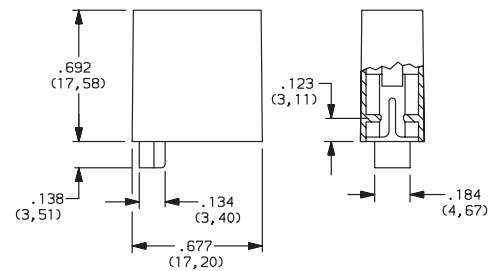

F07 FA120

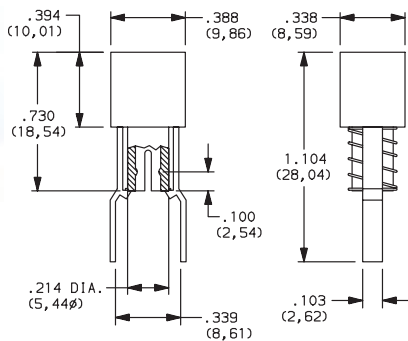

F08 FA201

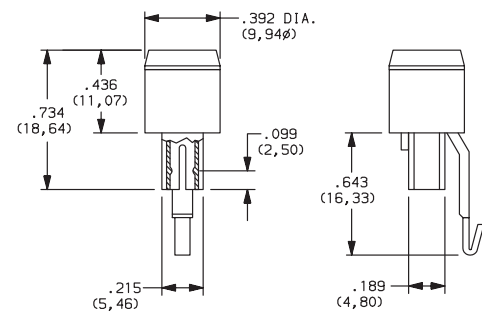

F11 FA200

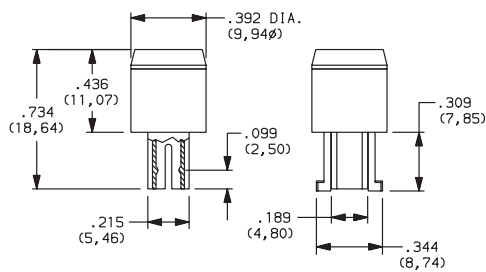

SHELL COLOR

01 BLACK

OUT POSITION COLOR

01 BLACK

IN POSITION COLOR

| OPTION CODE | COLOR |
|-------------|--------|
| 02 | WHITE |
| 06 | YELLOW |
| 07 | BLUE |
| 08 | GREEN |
| 12 | ORANGE |



Dimensions are shown: Inches (mm)
 Specifications and dimensions subject to change



F Series Pushbutton Switches

Pushbutton A

CHASSIS

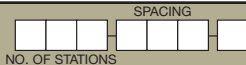

NUMBER OF STATIONS

C00 Thru C10 Comes with standard 0.094 (2,44mm) mounting holes

NOTE: Single station chassis available with mounting configurations, consult factory.

SPACING

00 SINGLE STATION

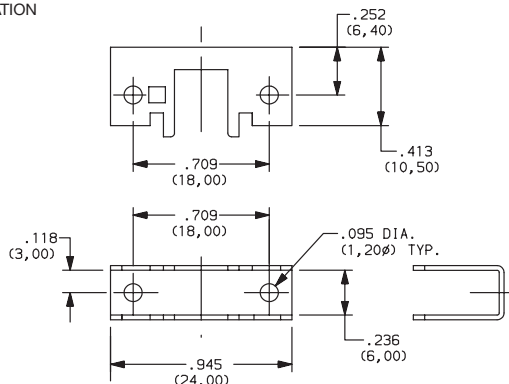

10 10mm

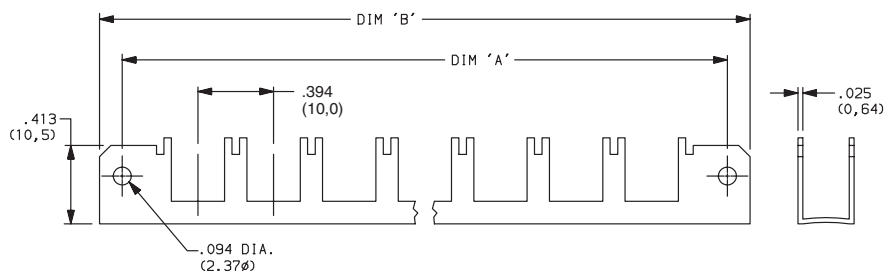

| No. of Stations | Dim. 'A' | Dim. 'B' | Tolerance |
|-----------------|-------------------|-------------------|-----------|
| 2 | 1.182 (30,02) | 1.418 (36,02) | 0.005 |
| 3 | 1.575 (40,01) | 1.811 (46,00) | 0.010 |
| 4 | 1.969 (50,01) | 2.205 (56,01) | 0.010 |
| 5 | 2.363 (60,02) | 2.599 (66,01) | 0.010 |
| 6 | 2.757 (70,03) | 2.993 (76,02) | 0.015 |
| 7 | 3.150 (80,01) | 3.386 (86,00) | 0.015 |
| 8 | 3.544 (90,02) | 3.780 (96,01) | 0.015 |
| 9 | 3.938 (100,03) | 4.174 (106,02) | 0.015 |
| 10 | 4.331 (110,01) | 4.567 (116,00) | 0.015 |

12.5 12.5mm

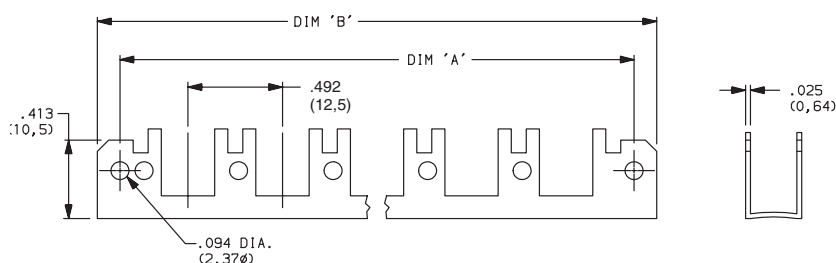

| No. of Stations | Dim. 'A' | Dim. 'B' | Tolerance |
|-----------------|-------------------|-------------------|-----------|
| 2 | 1.200 (30,48) | 1.436 (36,47) | 0.005 |
| 3 | 1.692 (42,98) | 1.928 (48,97) | 0.010 |
| 4 | 2.184 (55,47) | 2.420 (61,47) | 0.010 |
| 5 | 2.676 (67,97) | 2.912 (73,96) | 0.010 |
| 6 | 3.169 (80,49) | 3.405 (86,49) | 0.015 |
| 7 | 3.661 (92,99) | 3.897 (98,98) | 0.015 |
| 8 | 4.153 (105,49) | 4.389 (111,48) | 0.015 |
| 9 | 4.645 (117,98) | 4.881 (123,98) | 0.015 |
| 10 | 5.137 (130,48) | 5.373 (136,47) | 0.015 |



Dimensions are shown: Inches (mm)
Specifications and dimensions subject to change



F Series Pushbutton Switches



A

Pushbutton

CHASSIS

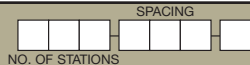

SPACING

15 15mm

| No. of Stations | Dim. 'A' | Dim. 'B' | Tolerance |
|-----------------|-------------------|-------------------|-----------|
| 2 | 1.374 (34,90) | 1.615 (41,02) | 0.005 |
| 3 | 1.969 (50,01) | 2.205 (56,01) | 0.010 |
| 4 | 2.560 (65,02) | 2.796 (71,02) | 0.010 |
| 5 | 3.150 (80,01) | 3.386 (86,00) | 0.010 |
| 6 | 3.741 (95,02) | 3.977 (101,02) | 0.015 |
| 7 | 4.332 (110,03) | 4.568 (116,03) | 0.015 |
| 8 | 4.922 (125,02) | 5.158 (131,01) | 0.015 |
| 9 | 5.513 (140,03) | 5.749 (146,02) | 0.015 |
| 10 | 6.103 (155,02) | 6.339 (161,01) | 0.015 |

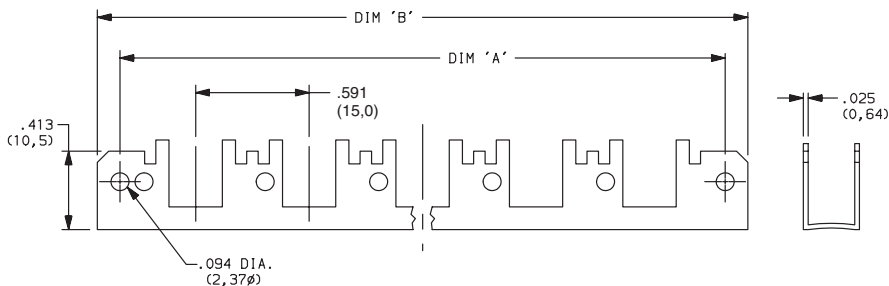

17.5 17.5mm

| No. of Stations | Dim. 'A' | Dim. 'B' | Tolerance |
|-----------------|-------------------|-------------------|-----------|
| 2 | 1.477 (37,52) | 1.713 (43,51) | 0.005 |
| 3 | 2.166 (55,02) | 2.402 (61,01) | 0.010 |
| 4 | 2.855 (75,52) | 3.091 (78,51) | 0.010 |
| 5 | 3.544 (90,02) | 3.780 (96,01) | 0.010 |
| 6 | 4.233 (107,52) | 4.469 (113,51) | 0.015 |
| 7 | 4.922 (125,02) | 5.158 (131,01) | 0.015 |
| 8 | 5.611 (142,52) | 5.847 (148,51) | 0.015 |
| 9 | 6.300 (160,02) | 6.536 (166,01) | 0.015 |
| 10 | 6.989 (177,52) | 7.225 (183,52) | 0.015 |

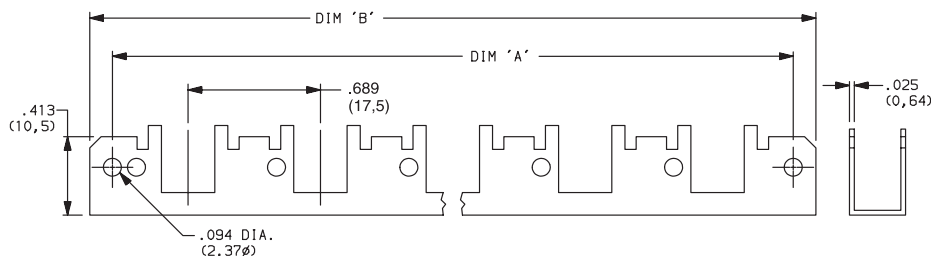

20 20mm

| No. of Stations | Dim. 'A' | Dim. 'B' | Tolerance |
|-----------------|-------------------|-------------------|-----------|
| 2 | 1.575 (40,01) | 1.811 (46,00) | 0.005 |
| 3 | 2.363 (60,02) | 2.599 (66,01) | 0.010 |
| 4 | 3.150 (80,01) | 3.386 (86,00) | 0.010 |
| 5 | 3.938 (100,03) | 4.174 (106,02) | 0.010 |
| 6 | 4.725 (120,02) | 4.961 (126,01) | 0.015 |
| 7 | 5.512 (140,00) | 5.748 (146,00) | 0.015 |
| 8 | 6.300 (160,02) | 6.536 (166,01) | 0.015 |
| 9 | 7.087 (180,01) | 7.323 (186,00) | 0.015 |
| 10 | 7.875 (200,03) | 8.111 (206,02) | 0.015 |

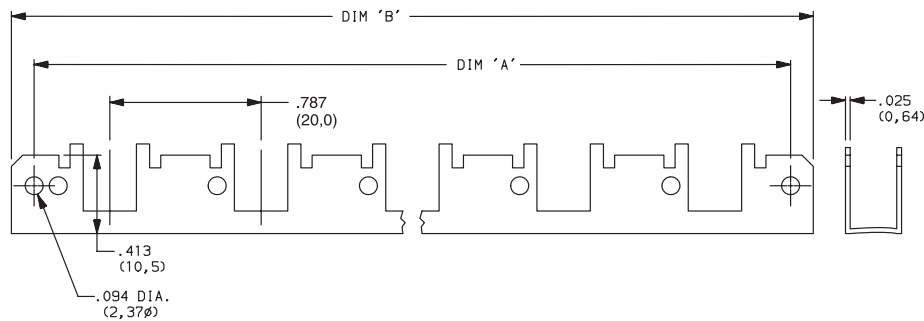

Third Angle Projection

Dimensions are shown: Inches (mm)
Specifications and dimensions subject to change





Pushbutton
A

NE-18 Series Mains / Power Switches

Features/Benefits

- Chassis or panel mount
- Various buttons
- Various contact configurations
- RoHS compliant

Typical Applications

- Mains/power switching
- Consumer electronics
- Audio equipment
- Digital products

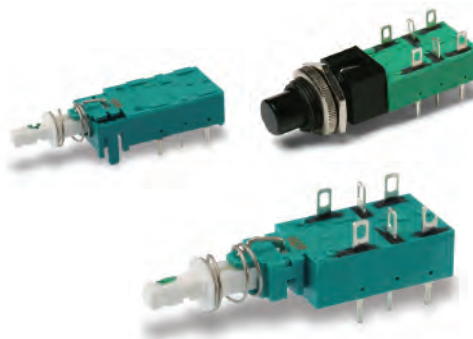

UL61058-1



Specifications

ELECTRICAL RATING:

NE18 Series:

- 8A GP, 125 VAC, 50/60 Hz, 1E4, T70
- 6A GP, 250 VAC, 50/60 Hz, 1E4, T70
- 6(4)A RM, 250 VAC, 50/60 Hz, 1E4, T70
- 6/48A RC, 250 VAC, 50/60 Hz, 1E4, T70
- 1RA, 100 VDC, 1E4, T70
- 8RA, 30VDC, 1E4, T70

NE18CTII Series:

- 4A GP, 250 VAC, 50/60 Hz, 1E4, T70
- 4/48A RC, 250 VAC, 50/60 Hz, 1E4, T70
- 1RA, 100 VDC, 1E4, T70
- 4RA, 30VDC, 1E4, T70

DIELECTRIC STRENGTH (50 Hz, 1 min.): 2000 V

OPERATING LIFE AT MAX. LOAD AND AT MAX. INRUSH CURRENT: $\wedge 10^4$ operations⁵⁾

CONTACT RESISTANCE: Initial: 50m Ω ; After 10^4 operations: 70m Ω .

INSULATION RESISTANCE: $\wedge 10^{12}$ Ω chassis – nearest contact; $\wedge 10^{12}$ Ω mains contact – mains contact; $\wedge 10^{12}$ Ω mains contact – mains contact after 10^4 operations.

LOW VOLTAGE CONTACT:

SWITCHING POWER MAX.: 12W

SWITCHING VOLTAGE MAX.: 24V

SWITCHING CURRENT MAX.: 0.5A

TOTAL TRAVEL: 4.7mm (.185 inch)

LATCHING TRAVEL: 3.3mm (.130 inch)

OPERATING FORCE: Without auxiliary low voltage contacts: NE18: 7N (700 grams); NE18CTII: 9.5N (950 grams).

With auxiliary low voltage contacts: NE18: 8N (800 grams); NE18CTII: 11N (1100 grams).

SEALING: Dust proof.

Materials

HOUSING, ACTUATOR & TERMINAL BOARD: Thermoplastic polyester (UL 94V-0).

MOVABLE CONTACT: Silver nickel alloy, silver plated.

FIXED CONTACTS: Silver nickel alloy, silver plated.

COMMON CONTACTS & TERMINALS: Copper alloy, silver plated.

RETURN SPRING: Music wire.

NOTE: All models are RoHS compliant and compatible.

NOTE: Specifications and materials listed above are for switches with standard options. For information on specific and custom switches, consult Customer Service Center.

Build-A-Switch

To order, simply select desired option from each category and place in the appropriate box. Available options are shown and described on pages A-97 thru A-104. For additional options not shown in catalog, consult Customer Service Center.

If requesting only a switch, select the switch as noted below. Buttons are sold separately.

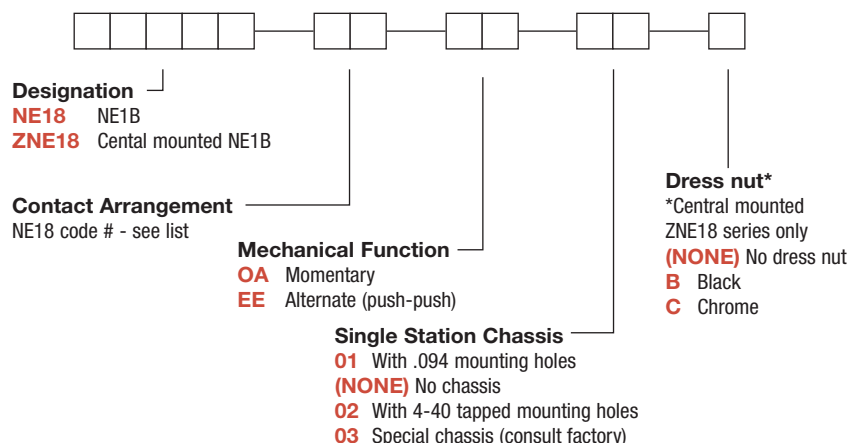

Dimensions are shown: Inches (mm)
Specifications and dimensions subject to change

NE-18 Series Mains / Power Switches



A
Pushbutton

Order Code - Buttons

Solid Buttons

| | | | | |
|------------|------|--------------|------------|--|
| | | | | |
| Style | | Button Color | | |
| F01 | FMR | 01 | Black | |
| F02 | FG* | 02 | White | |
| F12 | FSC | 03 | Red | |
| F13 | FSD | 04 | Light gray | |
| F14 | FU12 | | | |
| F15 | FSB | | | |
| F16 | FE | | | |
| F19 | FA | | | |
| F21 | F001 | | | |

Mechanical Indicator Buttons

| | | | | | |
|------------|--------|-------------------|--------|--------------------|--|
| | | | | | |
| Style | | Shell Color | | Out Position Color | |
| F01 | FA100 | 01 | Black | | |
| F02 | FA101 | | | | |
| F07 | FA120 | | | | |
| F08 | FA201 | | | | |
| F11 | FA200* | | | | |
| | | In Position Color | | | |
| | | 02 | White | | |
| | | 06 | Yellow | | |
| | | 07 | Blue | | |
| | | 08 | Green | | |
| | | 12 | Orange | | |

*Button options for central mounting configurations, use 'FG' for central mount with chrome dress nut, use 'FA200' for central mount with black dress nut.

BUTTON REMOVAL

A button of a push-push switch should only be removed in the "OFF" non-latching position.

DESIGNATION & SWITCHES WITH STANDARD OPTIONS



NE1838EE

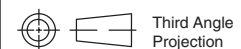
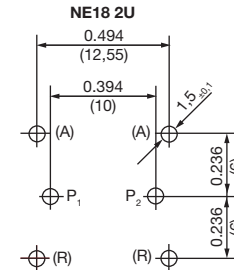
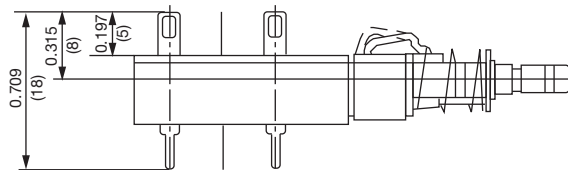
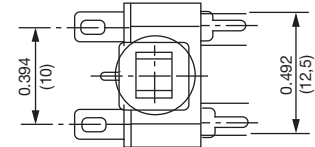
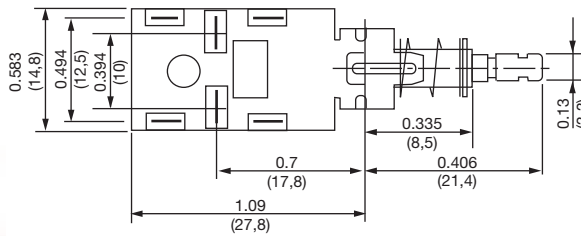
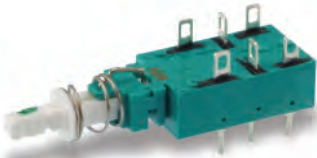

Dimensions are shown: Inches (mm)
 Specifications and dimensions subject to change



NE-18 Series Mains / Power Switches

DESIGNATION & SWITCHES WITH STANDARD OPTIONS



Pushbutton

NE1839EE

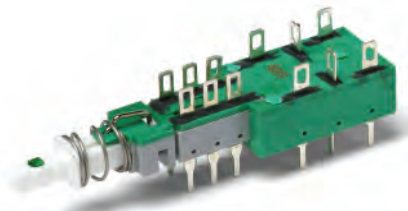
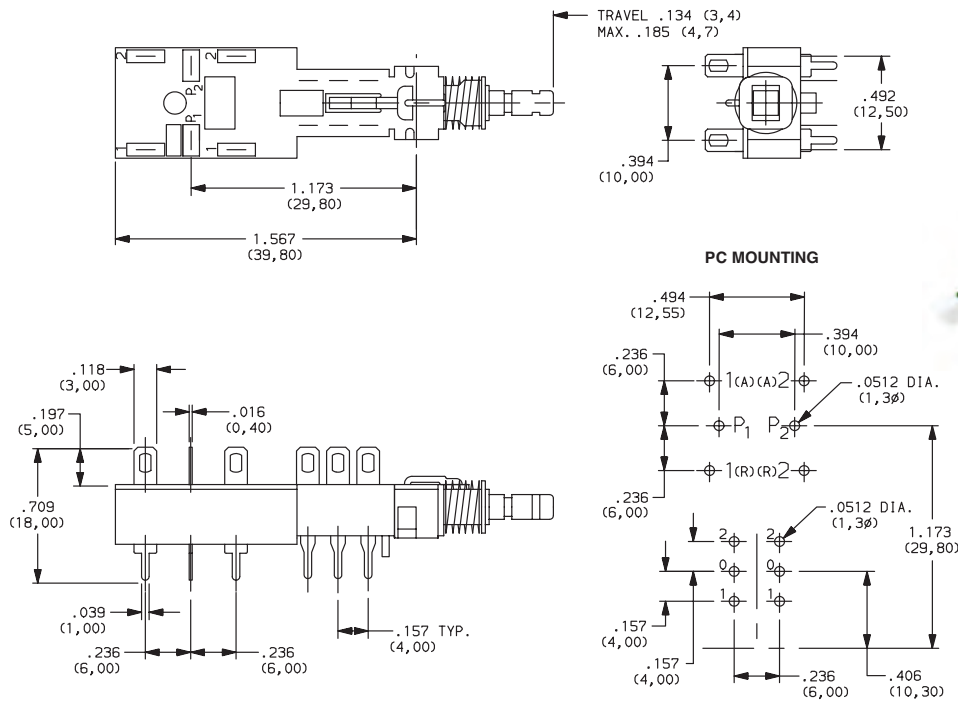

NE1846EE

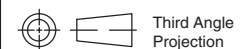
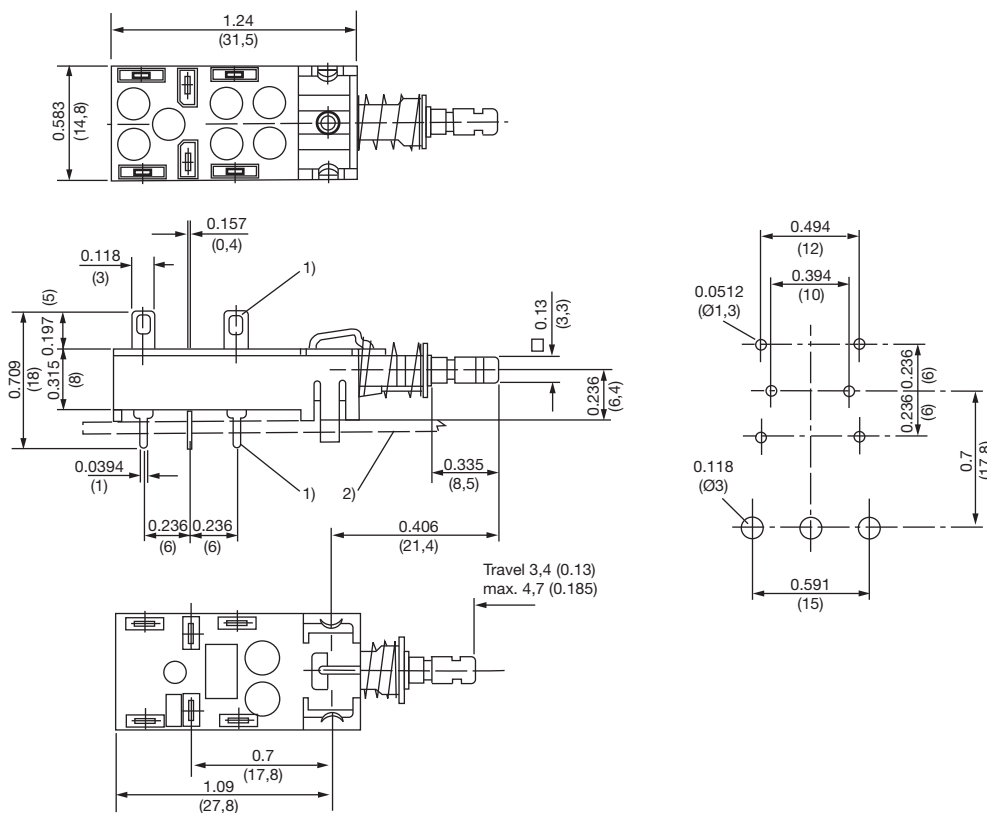

Dimensions are shown: Inches (mm)
Specifications and dimensions subject to change

NE-18 Series Mains / Power Switches



DESIGNATION & SWITCHES WITH STANDARD OPTIONS



ZNE1838EECF0201

A

Pushbutton

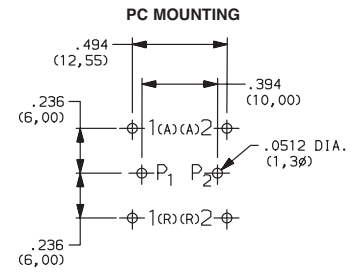
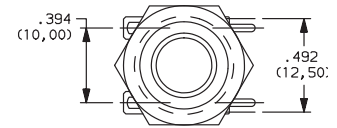
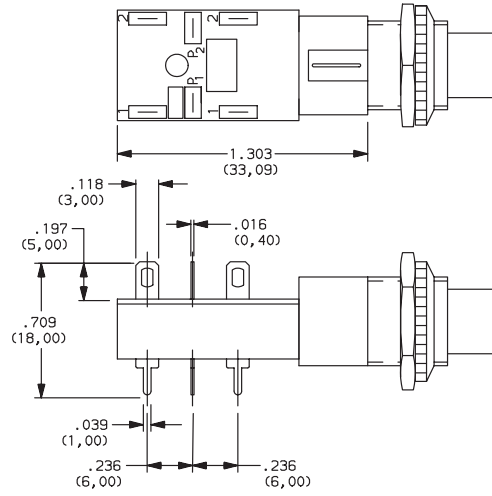

Third Angle
Projection

Dimensions are shown: Inches (mm)
Specifications and dimensions subject to change



NE-18 Series Mains / Power Switches

Pushbutton
A

CONTACT ARRANGEMENT

| OPTION CODE Contact capacity and availability | STYLE | ELECTRICAL CIRCUIT |
|---|-----------------|-----------------------|
| 37 | NE18 – 2AX | DPST |
| 38 | NE18 – 2UX | DPDT |
| 51 | 2U + NE18 – 2AX | DPST* |
| 52 (4A/64) | NE18CTII – 2AX | DPST |
| 39 | 2U + NE18 – 2UX | DPDT* |
| 41 | NE18 – 2AP | DPST |
| 42 | NE18 – 2UP | DPDT |
| 43 | NE18 – 2AW | DPST |
| 44 | NE18 – 2UW | DPDT |
| 45 | NE18 – 2ASX | DPST |

| OPTION CODE Contact capacity and availability | STYLE | ELECTRICAL CIRCUIT |
|---|---------------------|-----------------------|
| 46 | NE18 – 2USX | DPDT |
| 47 | NE18 – 2ASP | DPST |
| 48 | NE18 – 2USP | DPDT |
| 49 | NE18 – 2ASW | DPST |
| 50 | NE18 – 2USW | DPDT |
| 53 (4A/64) | 2U + NE18CTII – 2AX | DPST |
| 54 | 2U + NE18 – 2AW | DPST |
| 55 | 2U + NE18 – 2AP | DPST |
| 56 | 2U + NE18 – 2UW | DPDT |
| 57 | 2U + NE18 – 2UP | DPDT |

* 2U + Denotes auxiliary set of low current contacts DPDT
 2A = DPST
 2U = DPDT
 S = Snap-in mounting
 X = Solder lug/PC pins
 W = Solder lugs only
 P = PC pins only

NOTES
 1. Contact plating is silver on all Power Switches.
 2. The electrical function is Break Before Make (BBM) on all Power Switches.
 3. The terminals will be epoxy sealed.

| TYPE | POSSIBLE CONTACT ARRANGEMENT | | CONTACT SPACING | PROTECTION CLASS (CEE 24) | APPROVALS |
|----------|------------------------------|--------------------|----------------------|------------------------------|---------------|
| | POWER CONTACTS ¹ | AUXILIARY CONTACTS | | | |
| NE18 | 2A ² | 2U | > 3mm (.118 inch) | II | UL61058-1 |
| NE18 | 2A ² 2U | 2U | > 3mm (.118 inch) | I | UL61058-1 |
| NE18CTII | 2A ² | 2U | > 3mm (.118 inch) | II | UL61058-1 |

1) A = make contact, U = changeover contact
 2) With 2A mains contacts: Mounting only by PC pins is not sufficient.

MECHANICAL FUNCTION

| OPTION CODE | FUNCTION |
|-------------|-----------------------|
| OA | Momentary |
| EE | Alternate (push-push) |



Dimensions are shown: Inches (mm)
 Specifications and dimensions subject to change

NE-18 Series Mains / Power Switches



A

Pushbutton

SINGLE STATION CHASSIS



01 WITH .094 MOUNTING HOLES

(NONE) NO CHASSIS

02 WITH 4-40 TAPPED MOUNTING HOLES

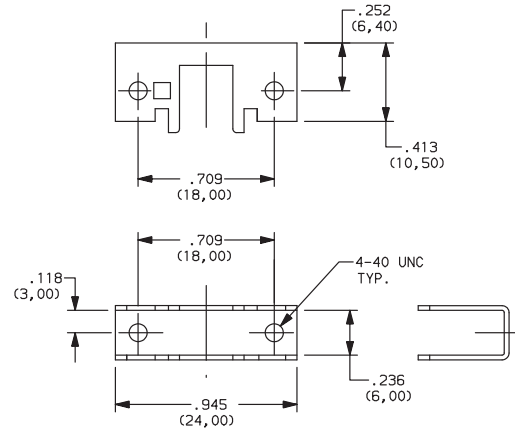
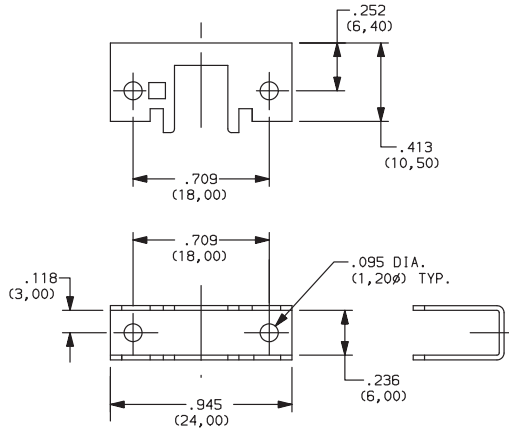

03 SPECIAL CHASSIS (CONSULT FACTORY)

DRESS NUT



(NONE) NO DRESS NUT

B BLACK

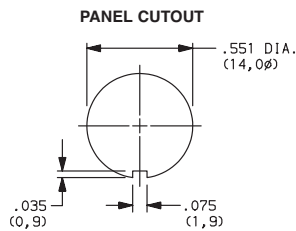
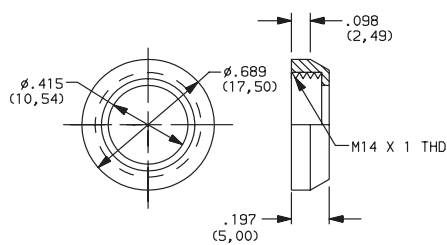

NOTE: Available with ZNE18 designation and FA200 buttons.

C CHROME

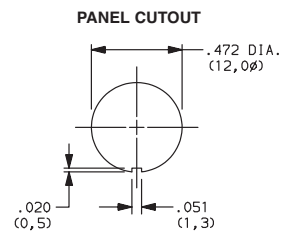
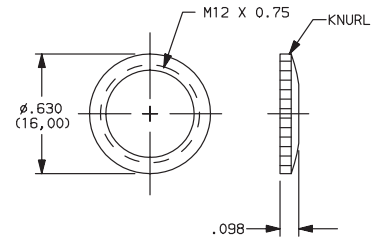

NOTE: Available with ZNE18 designation and FG button.



Dimensions are shown: Inches (mm)
Specifications and dimensions subject to change



NE-18 Series Mains / Power Switches

SOLID BUTTON

Pushbutton

A

STYLE

F01 FMR

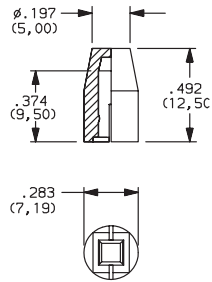

F02 FG

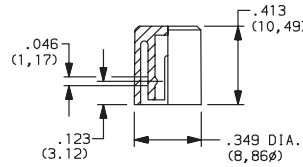

F12 FSC

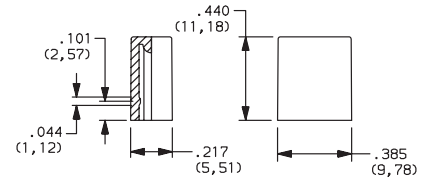

F13 FSD

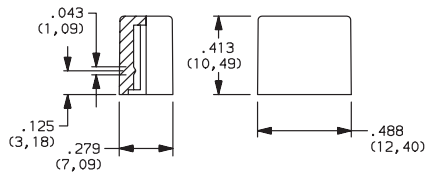
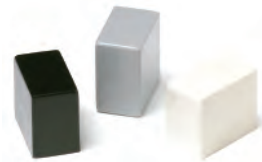

F14 FU12

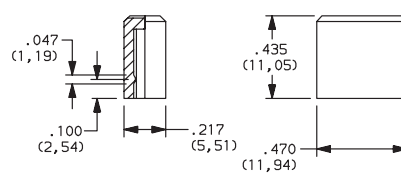
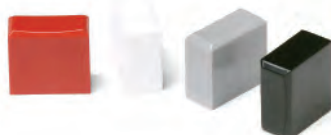

F15 FSB

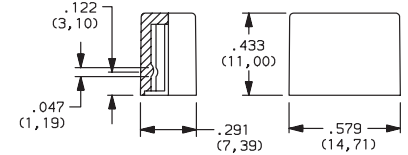
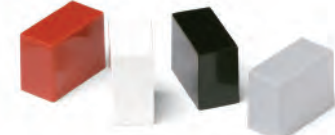

F16 FE

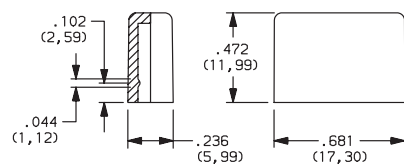

F19 FA

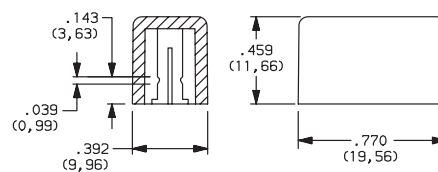

| OPTION CODE | COLOR |
|-------------|----------|
| 01 | BLACK |
| 02 | WHITE |
| 03 | RED |
| 04 | LT. GRAY |



Dimensions are shown: Inches (mm)
Specifications and dimensions subject to change



NE-18 Series Mains / Power Switches



A

Pushbutton

SOLID BUTTON



STYLE

F21 F001

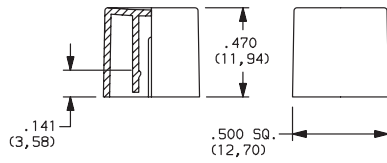

| OPTION CODE | COLOR |
|-------------|---|
| 01 | BLACK |
| 02 | WHITE |
| 03 | RED |
| 04 | LT. GRAY |
| 09 | BLACK/CHROME (F03, F06 & F07 buttons only) |

MECHANICAL BUTTON

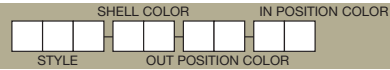

STYLE

F01 FA100

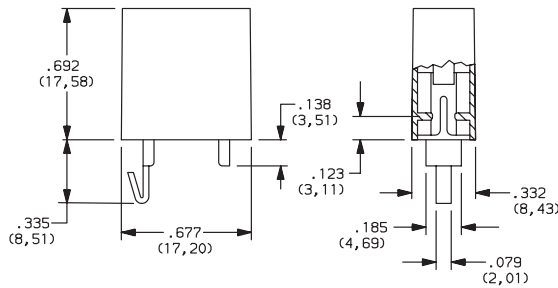

F02 FA101

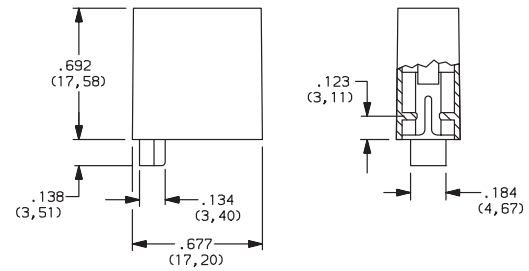

Third Angle
Projection

Dimensions are shown: Inches (mm)
Specifications and dimensions subject to change



NE-18 Series Mains / Power Switches

MECHANICAL BUTTON

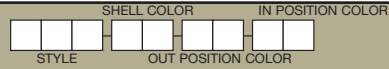

Pushbutton
A

STYLE

F08 FA201

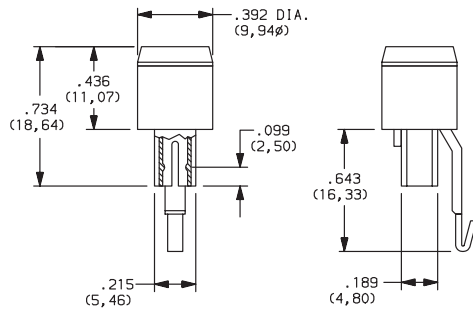

F11 FA200

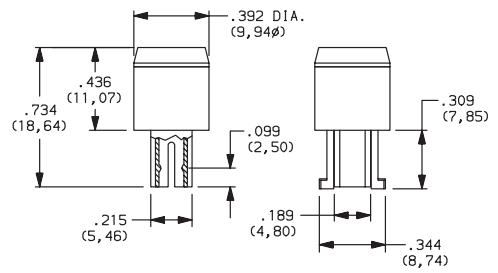

SHELL COLOR

01 BLACK

OUT POSITION COLOR

01 BLACK

IN POSITION COLOR

| OPTION CODE | COLOR |
|-------------|--------|
| 02 | WHITE |
| 06 | YELLOW |
| 07 | BLUE |
| 08 | GREEN |
| 12 | ORANGE |

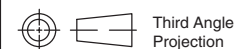

Dimensions are shown: Inches (mm)
Specifications and dimensions subject to change

FP Series Sealed Ultra Miniature Pushbutton Switches



A

Pushbutton

Features/Benefits

- Vertical and right angle mount
- Extended operating life 50,000 cycles
- Optional caps
- Sealed against soldering and cleaning processes
- RoHS compliant

Typical Applications

- Networking equipment
- Modems
- Reset functions
- Instrumentation

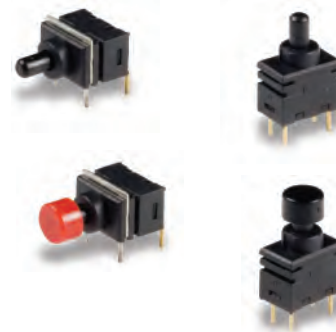

Specifications

CONTACT RATING: Max. 0.4 VA (28 V DC or V AC).
 ELECTRICAL LIFE: 50,000 cycles.
 CONTACT RESISTANCE: (10mA @ 2 V DC) 80 mΩ max. initial.
 INSULATION RESISTANCE: 500MΩ min. @ 500 V DC - 1 minute.
 OPERATING TEMPERATURE: -20°C to 80°C.
 SOLDERABILITY: Per MIL-STD-202F method 208D, or EIA RS-186E method 9.
 PACKAGING:
 Tray pack - 100 switches per tray.
 Caps (optional) - Bulk bag; 100 caps per bag.

Materials

MOVABLE CONTACTS:
 Base metal: Phosphor bronze
 Plating: Gold over nickel plate
 FIXED CONTACTS:
 Base metal: Brass
 Plating: Gold over nickel plate
 COVER: PA66 - Black
 ACTUATOR: PPS - Black
 BASE: PPS - Black
 SUPPORT BRACKET (A1 Terminal Style only): Steel with tin plate

NOTE: Specifications and materials listed above are for switches with standard options. For information on specific and custom switches, consult Customer Service Center.

Build-A-Switch

To order, simply select desired option from each category and place in the appropriate box. Available options are shown and described on pages A-106 thru A-107. For additional options not shown in catalog, consult Customer Service Center.

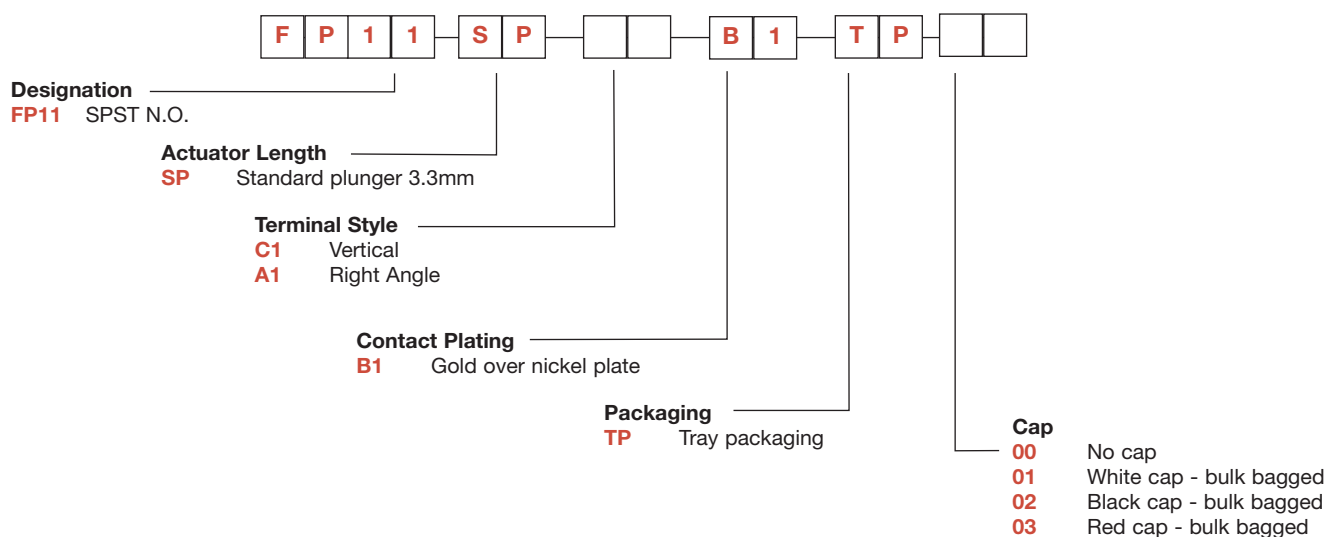

Dimensions are shown: Inches (mm)
 Specifications and dimensions subject to change



FP Series Sealed Ultra Miniature Pushbutton Switches

SWITCH FUNCTION

Pushbutton
A

C1 VERTICAL

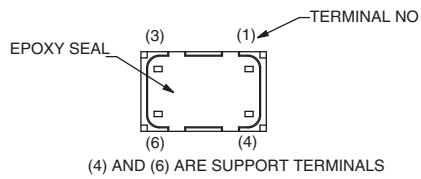
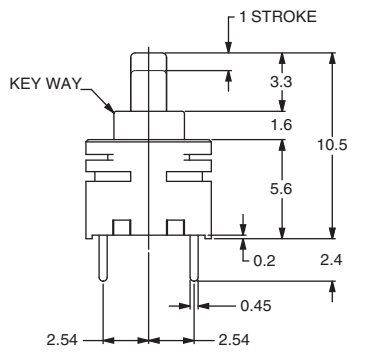
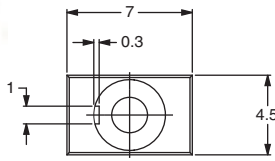

A1 RIGHT ANGLE

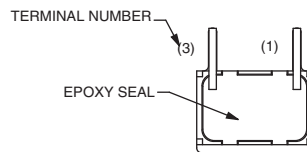
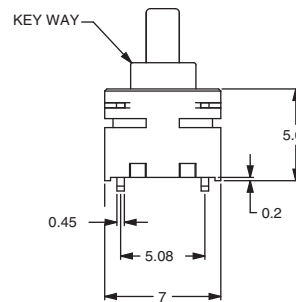
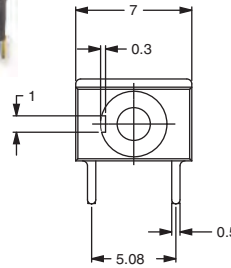

| MODEL NO. | SWITCH FUNCTION | |
|-----------|---------------------|--------|
| | POS. 1 | POS. 2 |
| FP11 | | |
| | CONNECTED TERMINALS | |
| | OPEN | 1-3 |

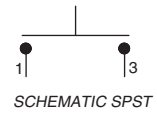

ACTUATOR LENGTH

SP STANDARD PLUNGER 3.3MM

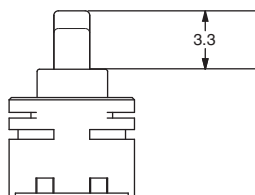

Dimensions are shown: mm
Specifications and dimensions subject to change

FP Series Sealed Ultra Miniature Pushbutton Switches



A

Pushbutton

TERMINAL STYLE

C1 VERTICAL

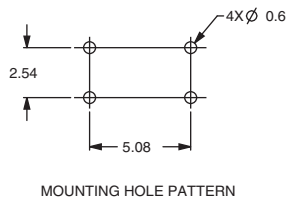
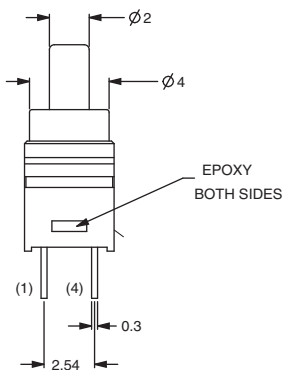

A1 RIGHT ANGLE

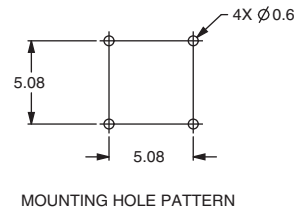
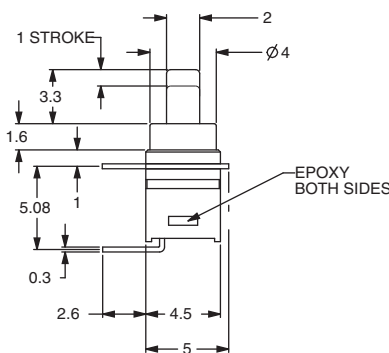

CONTACT PLATING

B1 GOLD OVER NICKEL PLATE

PACKAGING

TP TRAY PACKAGING

CAPS

| OPTION CODE | DESCRIPTION |
|-------------|------------------------|
| 00 | NO CAP |
| 01 | WHITE CAP, BULK BAGGED |
| 02 | BLACK CAP, BULK BAGGED |
| 03 | RED CAP, BULK BAGGED |

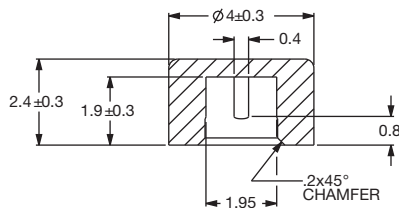

To purchase Caps separately without switch,
please use these part numbers

| PART # | COLOR |
|-----------|-------|
| 798D01000 | WHITE |
| 798D02000 | BLACK |
| 798D03000 | RED |



Dimensions are shown: mm
Specifications and dimensions subject to change

C&K



A
Pushbutton

AP Series Industrial Pushbutton Switch

Features/Benefits

- IP67 sealed
- 1,000,000 life cycle
- Illumination / non-illumination
- Multiple colored caps
- Threaded or snap-in mounting
- Caps available separately
- RoHS compliant

Typical Applications

- Harsh environments
- Off-Road
- Industrial
- Medical
- Transportation
- Joystick control modules
- Gaming
- Military



Specifications

FUNCTION: SPST Momentary
 CONTACT ARRANGEMENT: N.O.
 MOUNTING TYPE:
 Snap-in (no panel seal)
 Threaded body (hex nut, lock washer, and panel seal gasket provided)
 Torque spec for threaded body: Do not exceed 8-9 in-lbs (0.9-1.0 N.m)

Mechanical

OPERATING LIFE: 1,000,000 cycles
 TOTAL TRAVEL: 2.1 ± 0.2 mm
 OPERATING POINT 1.55 ± 0.25 mm
 OVER TRAVEL: 0.6 min.
 OPERATING FORCE: 4N ± 1N standard configuration; other force option 2N ± 0.5N
 VIBRATION: 10-500 Hz 10g Max
 SHOCK: 60g 11ms sawtooth wave

Electrical

CONTACT RATING:
 200mA @ 24 V DC resistive (500,000 cycles)
 100mA @ 50 V DC resistive (500,000 cycles)
 400mA @ 32 V AC resistive (500,000 cycles)
 125mA @ 125 V AC resistive (1,000,000 cycles)
 DIELECTRIC STRENGTH: 1000 V AC min.
 INSULATION RESISTANCE: 1 G Ω @ 500 VDC
 INITIAL CONTACT RESISTANCE 50 mΩ max (without wire leads)
 BOUNCE TIME: <5 ms

Materials

HOUSING: PBT
 BASE: PBT
 CAP: PBT
 ACTUATOR:
 Illuminated: Clear polycarbonate
 Non-illuminated: PBT
 INTERNAL SEAL: Silicone rubber
 TERMINALS: Copper alloy, gold over silver plating
 MOVABLE CONTACT: Copper alloy, gold over silver plating
 TERMINAL SEAL: Epoxy
 WIRE LEADS: UL1569 Black 22 AWG

Operating Environment

OPERATING TEMPERATURE: -40°C to 85°C (+105°C non-illuminated)
 ESD PROTECTION: 20 KV min.

Process Environment

SEALING: IP67 for threaded body
 IP65 for snap-in version (no panel seal)

NOTE: Specifications and materials listed above are for switches with standard options. For information on specific and custom switches, please contact Customer Service.

Build-A-Switch

To order, simply select desired option from each category and place in the appropriate box.

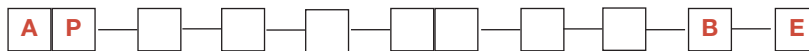

Designation

AP AP Series

Operating Force

2 2 Newtons
4 4 Newtons

Actuator Style

D Dome / Convex
C Concave
E Extended Dome
N None

Actuator Color

0 No Cap
2 Black
3 Red
4 Orange
5 Yellow
6 Green
7 Blue
9 Gray

Illumination

00 No LED*
01 Super White
02 Bi-color; Red (Green)
03 Red
05 Amber
06 Green
07 Super Blue
08 Bi-color; Amber (Green)

Bushing Style**

S** Snap-in plastic
T Threaded plastic

** No panel seal option

*** PC terminals not available with illumination

Contact Customer Service for additional hardware options.

Terminal Seal

E Epoxy
 All models are epoxy sealed

Contact Material

B Gold

Termination

Z Solder Lug
W 12" Wire Leads 22 AWG
C*** PC Terminals

Please contact Customer Service for additional colors and paint / laser etched button options.



* No LED available in short body only

Specifications and dimensions subject to change

AP Series Industrial Pushbutton Switch



A

Pushbutton

STANDARD VIEW

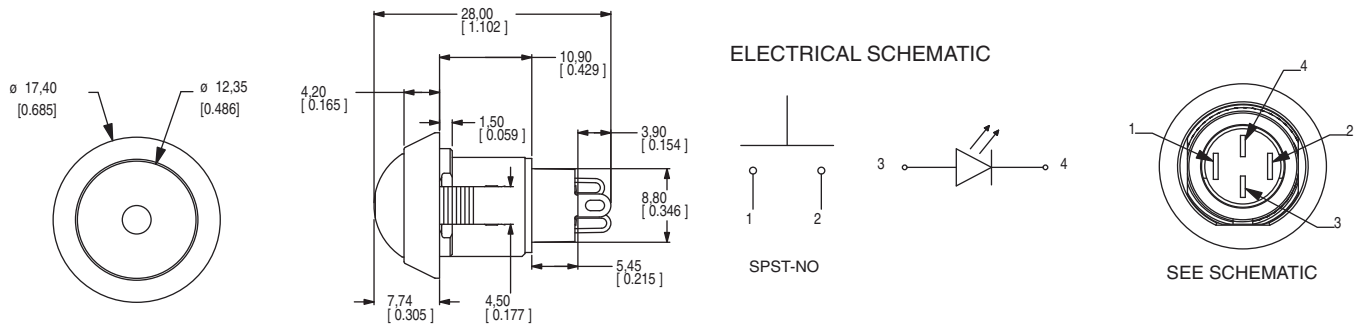

OPERATING FORCE

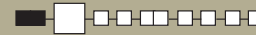

| OPTION CODE | OPERATING FORCE |
|-------------|-----------------|
| 2 | 2 N, 200 g |
| 4 | 4 N, 400 g |

ACTUATOR STYLE

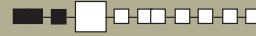

D DOME / CONVEX

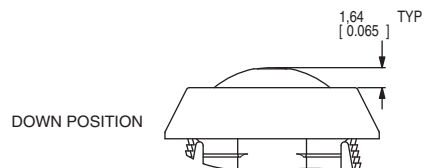
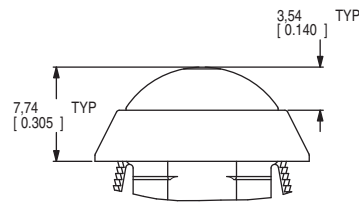

E EXTENDED DOME

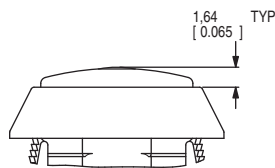
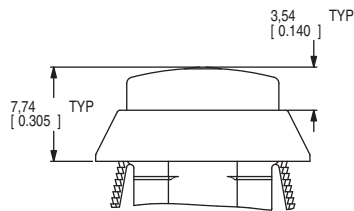

C CONCAVE

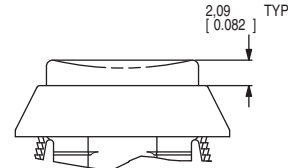
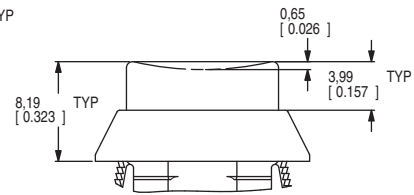

ACTUATOR COLOR



| OPTION CODE | ACTUATOR COLOR |
|-------------|----------------|
| 0 | No Cap |
| 2 | Black |
| 3 | Red |
| 4 | Orange |
| 5 | Yellow |
| 6 | Green |
| 7 | Blue |
| 9 | Gray |

For additional colors please contact Customer Service.

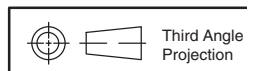

Dimensions are shown: mm (inches)
Specifications and dimensions subject to change



AP Series Industrial Pushbutton Switch

Pushbutton
A

ILLUMINATION



| OPTION CODE | ILLUMINATION TYPE | TYPICAL INTENSITY* | | PEAK WAVELENGTH | Vf Forward Voltage |
|-------------|------------------------------|--------------------|-------|-----------------|--------------------|
| | | MIN | MAX | | |
| | | (mcd) | | (nm) | |
| 00 | Model without illumination | N/A | | N/A | |
| 01 | LED Super White | 4,000 | 5,000 | N/A | 3.5 |
| 02 | LED Bi-Color – Red (Green) | 10 | 20 | 635/565 | 2.0 |
| 03 | LED Red | 4 | 8 | 700 | 2.0 |
| 05 | LED Amber | 35 | 50 | 610 | 2.0 |
| 06 | LED Green | 35 | 50 | 565 | 2.0 |
| 07 | LED Super Blue | 800 | 1,500 | 470 | 3.8 |
| 08 | LED Bi-Color – Amber (Green) | 10 | 10 | 585/565 | 2.0 |

*LED FORWARD CURRENT: 20 mA
LED FORWARD VOLTAGE: see chart above
LED REVERSE VOLTAGE: 5.0 V MAX

* For information on specific and custom LED, please contact Customer Service.

NOTE:
For bi-color LED's the polarity must be reversed to alternate the color

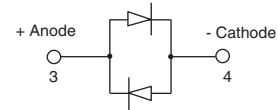

BUSHING STYLE



S SNAP-IN

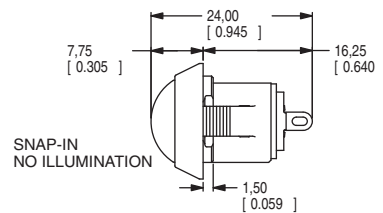
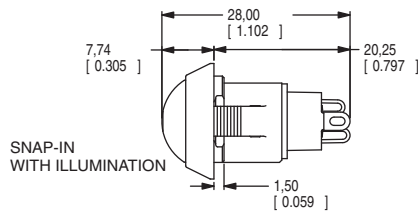

T THREADED PLASTIC

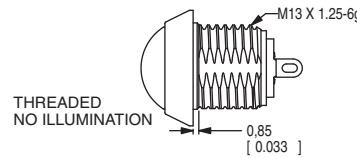
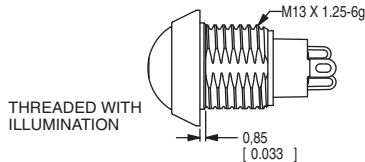

PANEL CUTOUT

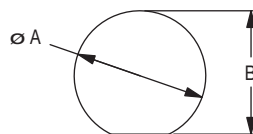

| PANEL THICKNESS | DIM A (± 0.05 mm) | DIM B (± 0.05 mm) |
|---|------------------------|------------------------|
| 1 mm [0.039 in] | 13.70 mm [0.539 in] | 13.00 mm [0.512 in] |
| 2 mm [0.079 in] | 13.80 mm [0.539 in] | 13.00 mm [0.512 in] |
| 3 mm [0.118 in] | 13.90 mm [0.547 in] | 13.10 mm [0.516 in] |
| THREADED BODY MIN PANEL THICKNESS 1 mm | 13.70 mm [0.539 in] | 13.00 mm [0.512 in] |

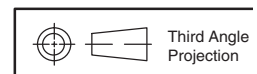

A 0.1mm min. chamfer on the leading edge of the mounting hole is recommended for snap-in version.

Dimensions are shown: mm (inches)
Specifications and dimensions subject to change

AP Series Industrial Pushbutton Switch



A

Pushbutton

TERMINATION



Z SOLDER LUG

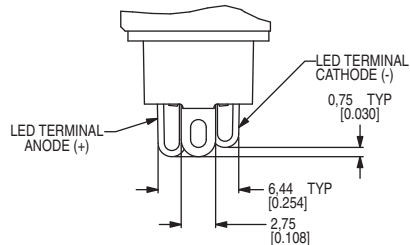
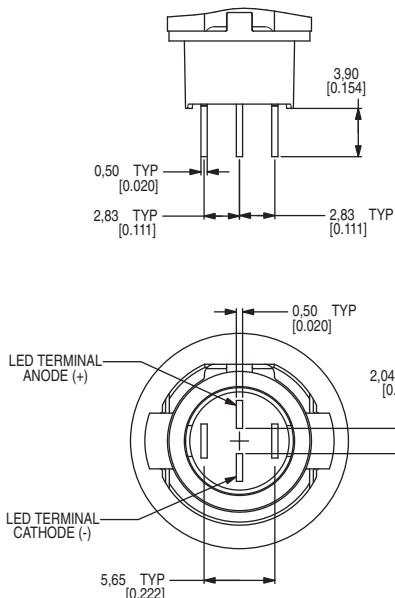

* Switching terminals are gold and LED terminals are silver

C PC TERMINALS

*** Illumination not available with PC Terminals

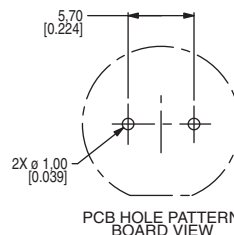
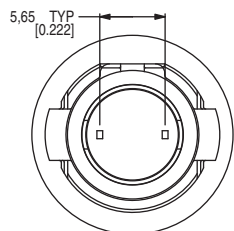
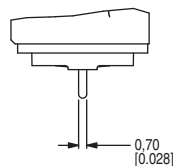
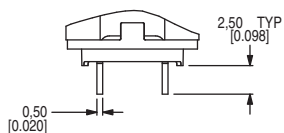

W 12" WIRE LEADS 22 AWG

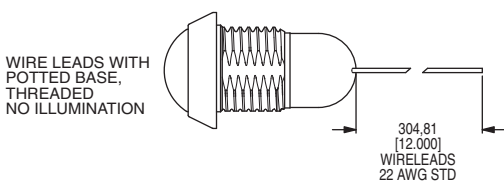
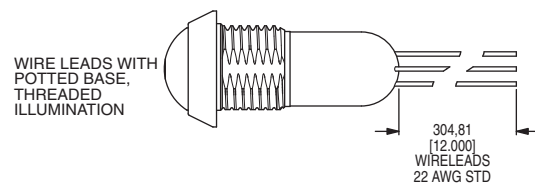
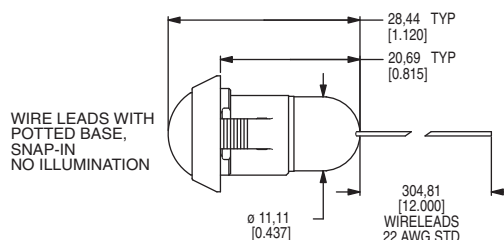
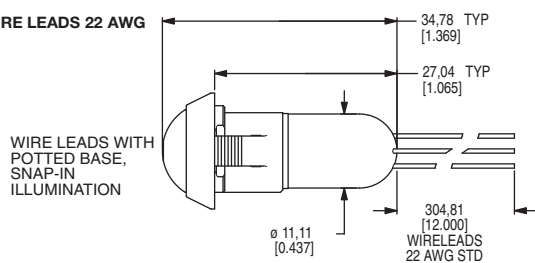

Wires: Black wires - Terminals
Red wires - LED (+) Positive
White wire - LED (-) Negative

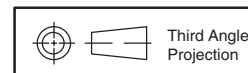

Dimensions are shown: mm (inches)
Specifications and dimensions subject to change



AP Series Industrial Pushbutton Switch

A

Pushbutton

CONTACT MATERIAL



B GOLD

| OPTION CODE | CONTACT MATERIAL |
|-------------|------------------|
| B | Gold |

TERMINAL SEAL



E EPOXY

All models are epoxy sealed

HARDWARE

LOCK WASHER

Part Number 647D00000

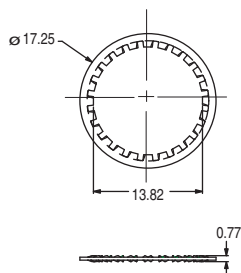

HEX NUT

Part number 515D00000

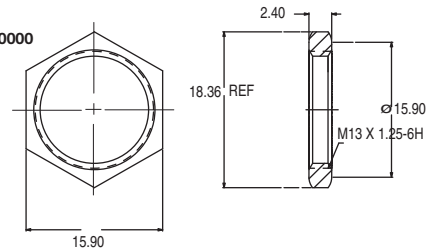

PANEL SEAL

Part Number 655D00000

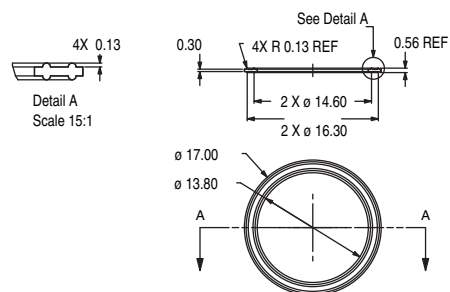

Caps available on next page

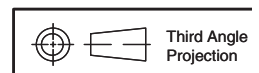

Dimensions are shown: mm (inches)
Specifications and dimensions subject to change



AVAILABLE CAPS



481D **XX** **XXX**

Cap Color ———
Style ———

| OPTION | CAP COLOR |
|--------|-----------|
| 01 | WHITE |
| 02 | BLACK |
| 03 | RED |
| 04 | ORANGE |
| 05 | YELLOW |
| 06 | GREEN |
| 07 | BLUE |
| 08 | BROWN |
| 09 | GRAY |

| PART NUMBER | HOLE | STYLE |
|-------------|------|---------------|
| 481DXX000 | NO | DOME |
| 481DXX001 | YES | DOME |
| 481DXX002 | NO | EXTENDED DOME |
| 481DXX003 | YES | EXTENDED DOME |
| 481DXX004 | NO | CONCAVE |
| 481DXX005 | YES | CONCAVE |

DOME

481DXX000 = NO HOLE
481DXX001 = HOLE

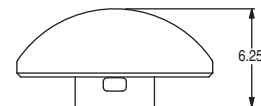
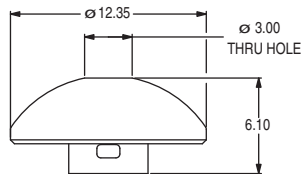

EXTENDED DOME

481DXX002 = NO HOLE
481DXX003 = HOLE

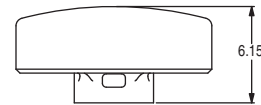
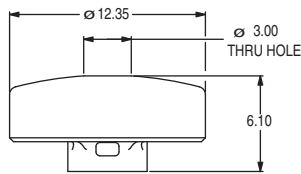

CONCAVE

481DXX004 = NO HOLE
481DXX005 = HOLE

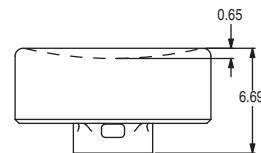
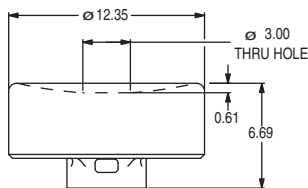



APB Series Backlit Pushbutton Switch

Pushbutton
A

Features/Benefits

- IP67 sealed
- 1,000,000 life cycle
- Illumination
- Threaded or snap-in mounting
- RoHS compliant

Typical Applications

- Harsh environments
- Off-Road
- Industrial
- Medical
- Transportation
- Joystick control modules
- Gaming
- Military



Specifications

FUNCTION: SPST Momentary
 CONTACT ARRANGEMENT: N.O.
 MOUNTING TYPE:
 Snap-in (no panel seal)
 Threaded body (hex nut, lock washer, and panel seal gasket provided)
 Torque spec for threaded body: Do not exceed 8-9 in-lbs (0.9-1.0 N.m)

Mechanical

OPERATING LIFE: 1,000,000 cycles
 TOTAL TRAVEL: 2.1 ± 0.2 mm
 OPERATING POINT 1.55 ± 0.25 mm
 OVER TRAVEL: 0.6 min.
 OPERATING FORCE: 4N ± 1N standard configuration; other force
 option 2N ± 0.5N
 VIBRATION: 10-500 Hz 10g Max
 SHOCK: 60g 11ms sawtooth wave

Electrical

CONTACT RATING:
 200mA @ 24 V DC resistive (500,000 cycles)
 100mA @ 50 V DC resistive (500,000 cycles)
 400mA @ 32 V AC resistive (500,000 cycles)
 125mA @ 125 V AC resistive (1,000,000 cycles)
 DIELECTRIC STRENGTH: 1000 V AC min.
 INSULATION RESISTANCE: 1 G Ω @ 500 VDC
 INITIAL CONTACT RESISTANCE 50 mΩ max (without wire leads)
 BOUNCE TIME: <5 ms

Materials

HOUSING: PBT
 BASE: PBT
 CAP: Painted polycarbonate
 ACTUATOR:
 Illuminated: Clear polycarbonate
 INTERNAL SEAL: Silicone rubber
 TERMINALS: Copper alloy, gold over silver plating
 MOVABLE CONTACT: Copper alloy, gold over silver plating
 TERMINAL SEAL: Epoxy
 WIRE LEADS: UL1569 Black 22 AWG

Operating Environment

OPERATING TEMPERATURE: -40°C to 85°C
 ESD PROTECTION: 20 KV min.

Process Environment

SEALING: IP67 for threaded body
 IP65 for snap-in version (no panel seal)

NOTE: Specifications and materials listed above are for switches with standard options. For information on specific and custom switches, please contact Customer Service.

Build-A-Switch

To order, simply select desired option from each category and place in the appropriate box.

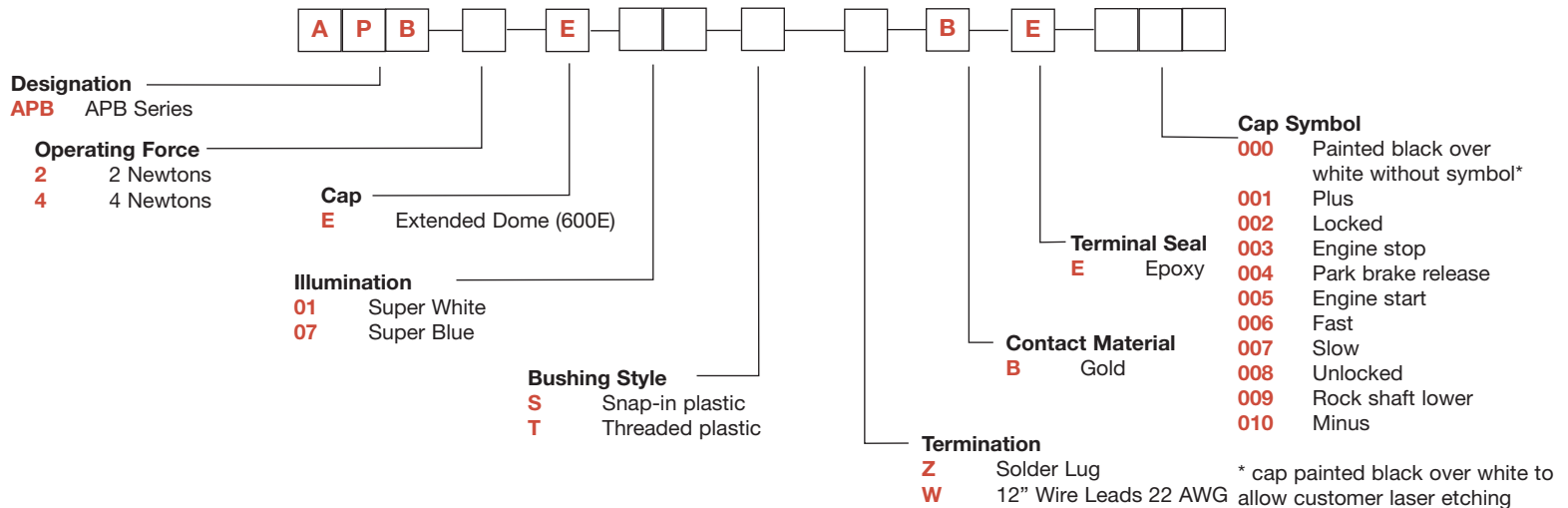

APB Series Backlit Pushbutton Switch



A

Pushbutton

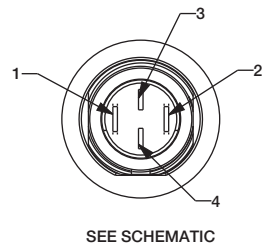
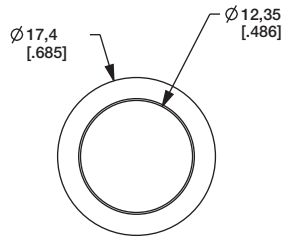
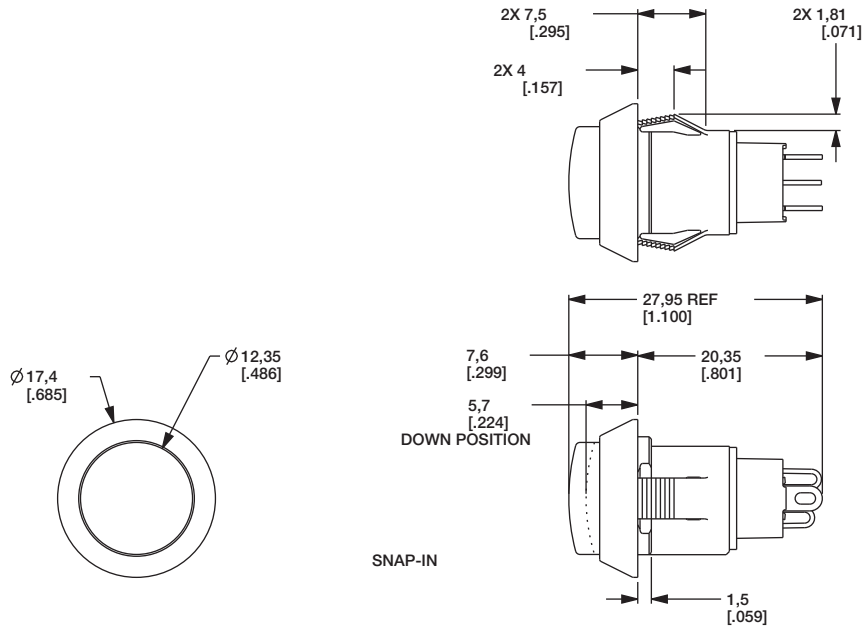

THREADED

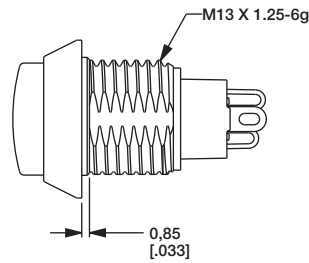

ELECTRICAL SCHEMATIC

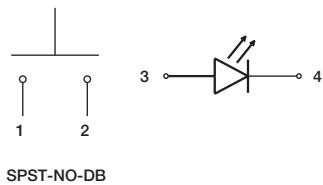

SPST-NO-DB

PANEL CUTOUT

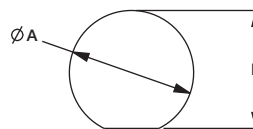

| PANEL THICKNESS | DIM A (±0.05 MM) | DIM B (±0.05 MM) |
|---|------------------------|------------------------|
| 1 MM [0.039 IN] | 13.70 MM [0.539 IN] | 13.00 MM [0.512 IN] |
| 2 MM [0.079 IN] | 13.80 MM [0.539 IN] | 13.00 MM [0.512 IN] |
| 3 MM [0.118 IN] | 13.90 MM [0.547 IN] | 13.10 MM [0.516 IN] |
| THREADED BODY MIN PANEL THICKNESS 1 MM | 13.70 MM [0.539 IN] | 13.00 MM [0.512 IN] |

A 0.1 MM MIN CHAMFER ON THE LEADING EDGE OF MOUNTING HOLE IS RECOMMENDED FOR SNAP-IN VERSION.

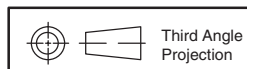

Third Angle
Projection



12 Oct 16

A-115

Dimensions are shown: Inches (mm)
Specifications and dimensions subject to change

www.ck-components.com



APB Series Backlit Pushbutton Switch

TERMINATION

Pushbutton

A

W 12" WIRE LEADS

Z SOLDER LUG

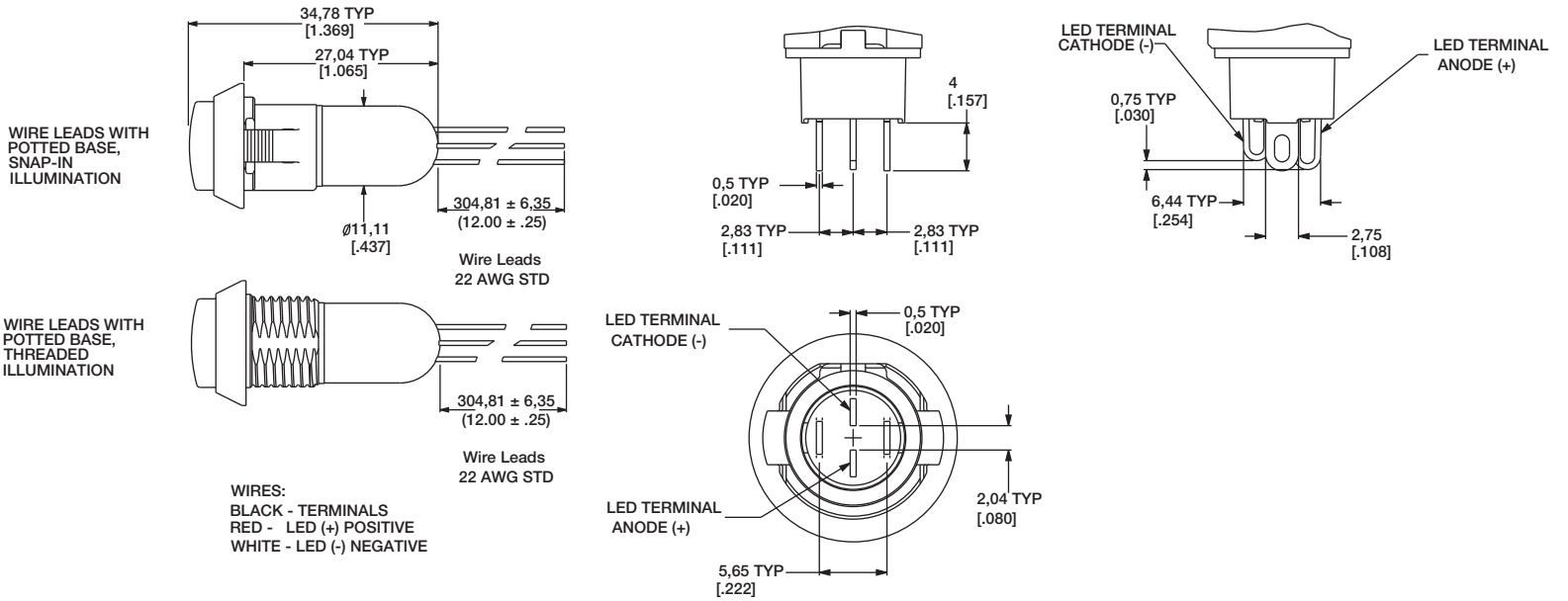

CONTACT MATERIAL

B GOLD

| OPTION CODE | CONTACT MATERIAL |
|-------------|------------------|
| B | Gold |

TERMINAL SEAL

E EPOXY

All models are epoxy sealed

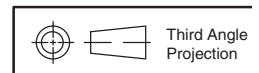

12 Oct 16

A-116

Dimensions are shown: Inches (mm)
Specifications and dimensions subject to change

www.ck-components.com

APB Series Backlit Pushbutton Switch



A

CAP SYMBOLS

| | | | |
|--|------|--|--------------------|
| | -000 | | NO SYMBOL |
| | -001 | | PLUS |
| | -002 | | LOCKED |
| | -003 | | ENGINE STOP |
| | -004 | | PARK BRAKE RELEASE |
| | -005 | | ENGINE START |

| | | | |
|--|------|--|------------------|
| | -006 | | FAST |
| | -007 | | SLOW |
| | -008 | | UNLOCKED |
| | -009 | | ROCK SHAFT LOWER |
| | -010 | | MINUS |

PANEL CUTOUT

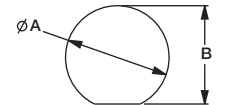

Panel Orientation
Flat indicates bottom

See chart on previous page
for dimensions

NOTES:
1. ALL GRAPHICS MUST BE POSITIONED AS SHOWN, PERPENDICULAR TO ALIGNMENT FEATURE ON UNDERSIDE OF CAP.
2. GRAPHIC MARKING MUST BE ALIGNED WITH THE FLAT FEATURE ON THE UNDERSIDE OF THE CAP AS SHOWN, TOLERANCE $\pm 3^\circ$

HARDWARE

LOCK WASHER
Part Number 647D00000

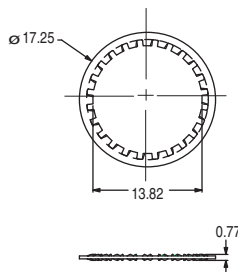

HEX NUT
Part number 515D00000

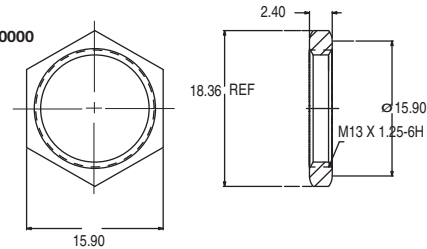

PANEL SEAL
Part Number 655D00000

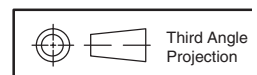
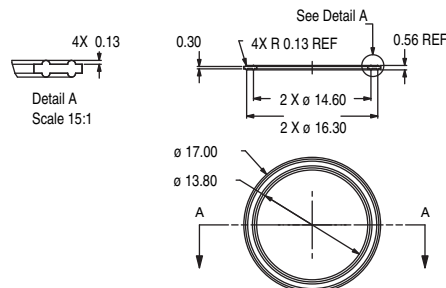

12 Oct 16

A-117

Dimensions are shown: Inches (mm)
Specifications and dimensions subject to change

www.ck-components.com



HP Series Hall Effect Pushbutton Switch

Pushbutton
A

Features/Benefits

- IP68 sealed
- 10,000,000 life cycle
- Multiple colored caps
- Redundant output available

Typical Applications

- Harsh environments
- Off-Road
- Industrial
- Medical
- Transportation
- Joystick control modules
- Gaming
- Military



Specifications

FUNCTION: Linear output (See chart on next page)
MOUNTING TYPE: Front mount, Rear mount

Mechanical

MECHANICAL TRAVEL: 0.150 (3.81mm)
SHOCK: 60g 11ms sawtooth wave
VIBRATION: 10-500Hz 10g max.

Electrical

SUPPLY VOLTAGE: 5 ± 0.5 VDC
SUPPLY CURRENT: 10mA max.
OUTPUT CURRENT: 1mA max.
OUTPUT VOLTAGE: Programable from 0.5 -4.5V
ESD PROTECTION: 16kV per EIA-545

Materials

CASE / BUSHING: Anodized Aluminum
INSIDE HOUSING: PBT
CAP: PBT
ACTUATOR: PBT

Operating Environment

OPERATING TEMPERATURE: -40°C to 85°C
OPERATING LIFE: 10,000,000 cycles
SEALING: IP68S

NOTE: Specifications and materials listed above are for switches with standard options. For information on specific and custom switches, please contact Customer Service.

Build-A-Switch

To order, simply select desired option from each category and place in the appropriate box.

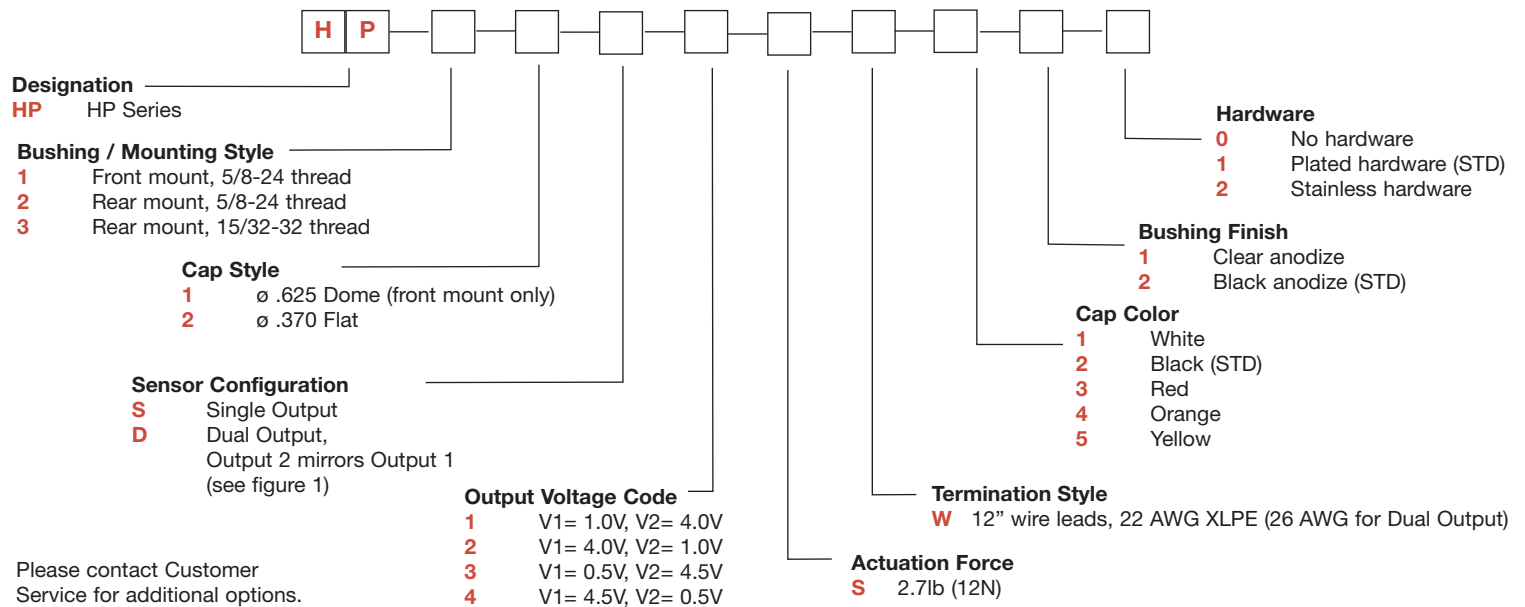

Specifications and dimensions subject to change

HP Series Hall Effect Pushbutton Switch



A

Pushbutton

STANDARD VIEW

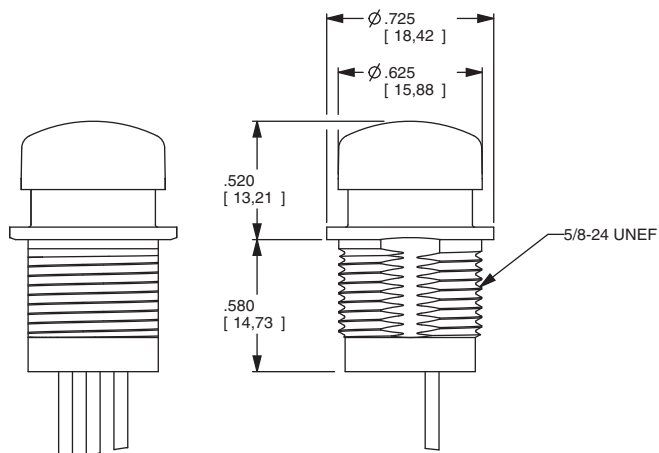

HP11

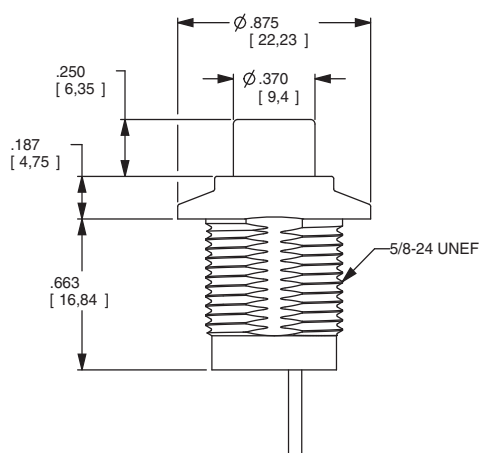

HP12

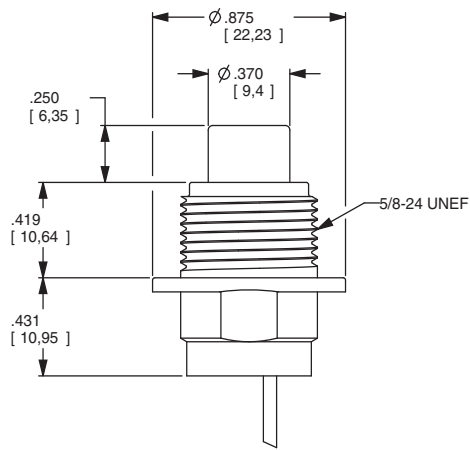

HP22

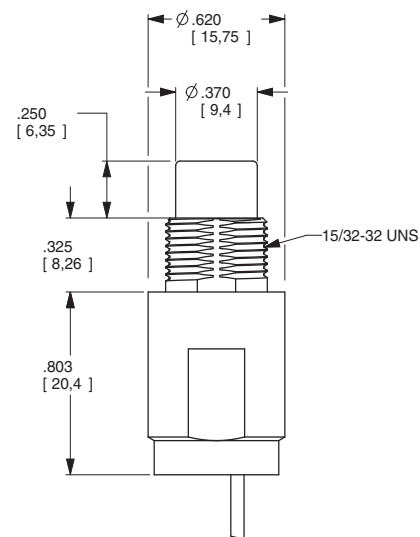

HP32

FIGURE 1: OUTPUT VOLTAGE

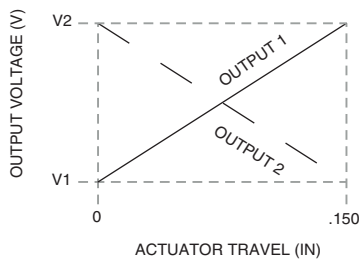
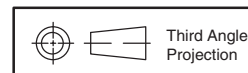
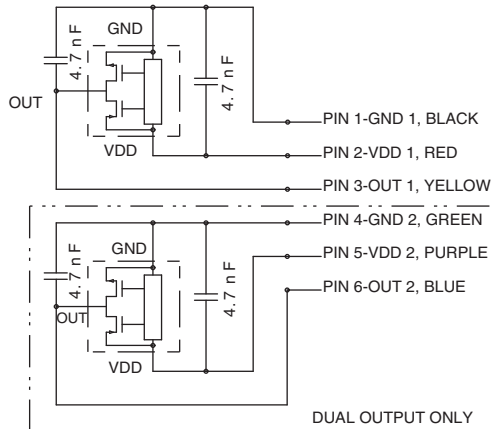

FIGURE 2- SCHEMATIC



Third Angle
Projection



Dimensions are shown: Inches (mm)
Specifications and dimensions subject to change



NP Series Sealed Industrial Pushbutton Switch

Pushbutton
A

Features/Benefits

- IP68 sealed
- 1,000,000 life cycle
- Multiple housing styles
- Capable of up to 5A resistive load
- Wirelead options available
- RoHS compliant

Typical Applications

- Harsh environments
- Off-Road
- Industrial
- Transportation
- Military



Specifications

FUNCTION: SPDT Double Break (Form Z) Momentary
CONTACT ARRANGEMENT: N.O. and N.C.
MOUNTING TYPE: Threaded front or rear mount and slot mount
TORQUE SPEC FOR THREADED BODY: Do not exceed 50 in-lbs (5.65 N-m)

Mechanical

OPERATING LIFE: 1,000,000 cycles
TOTAL TRAVEL: 1.6 ± 0.15 mm
OPERATING POINT 0.9 ± 0.25 mm
OVER TRAVEL: 0.45 min.
OPERATING FORCE: 8N ± 1.5N
VIBRATION: 10-500 Hz 10g Max
SHOCK: 50g 11ms sawtooth wave

Electrical

CONTACT RATING:
Option G - Gold over Silver
10mA/5 VDC (1,000,000 cycles)
Option Q - Silver
1A/32 VDC resistive (100,000 cycles)
5A/32 VDC resistive (25,000 cycles)
3A/32 VDC resistive (25,000 cycles)

Electrical (cont.)

DIELECTRIC STRENGTH: 1000 V AC for 1 min.
INSULATION RESISTANCE: 1 G Ω @ 500 VDC
INITIAL CONTACT RESISTANCE 50 mΩ max (without wire leads)
BOUNCE TIME: <5 ms

Materials

HOUSING: 6061-T6 Aluminum, black or clear anodized
BASE: PBT
CAP: PBT
ACTUATOR: PBT
INTERNAL SEAL: Silicone rubber
TERMINALS: Copper with silver nickel inlay, silver plating
MOVABLE CONTACT: Copper alloy, gold over silver plating
TERMINAL SEAL: Epoxy

Operating Environment

OPERATING TEMPERATURE: -40°C to +85°C
ESD PROTECTION: 15KV min.

Process Environment

SEALING: IP68

NOTE: Specifications and materials listed above are for switches with standard options. For information on specific and custom switches, please contact Customer Service.

Build-A-Switch

To order, simply select desired option from each category and place in the appropriate box.

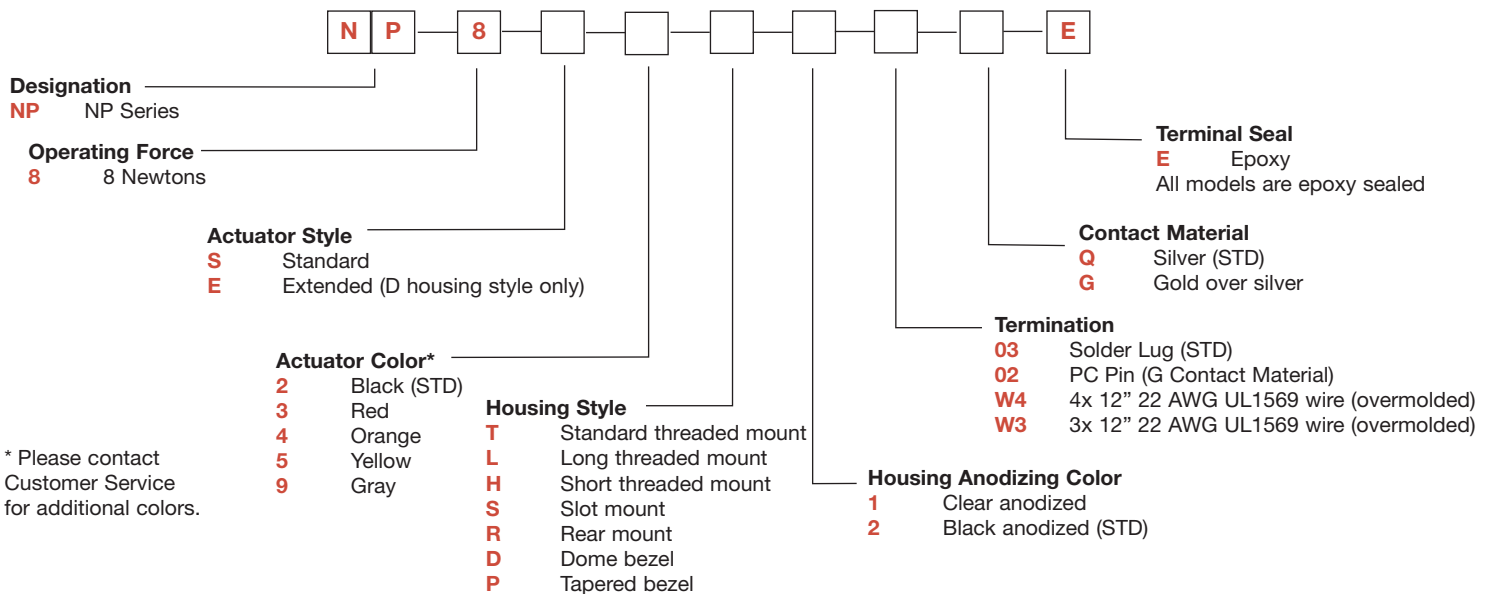

Specifications and dimensions subject to change

NP Series Sealed Industrial Pushbutton Switch



A

Pushbutton

STANDARD VIEW

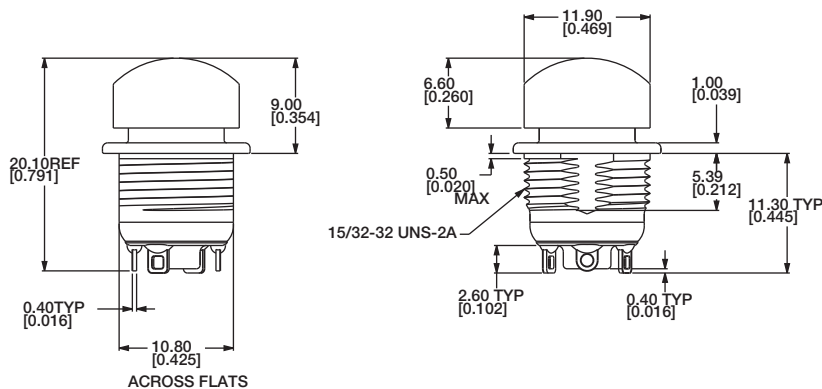

ELECTRICAL SCHEMATIC

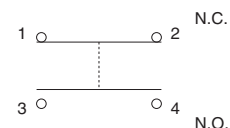

OPERATING FORCE

| OPTION CODE | OPERATING FORCE |
|-------------|-----------------|
| 8 | 8 N |

ACTUATOR STYLE

S STANDARD

E EXTENDED (D HOUSING STYLE ONLY)

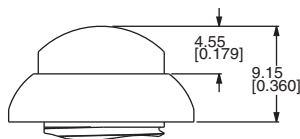
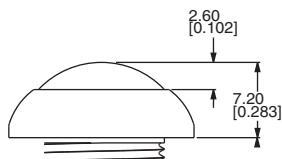

ACTUATOR COLOR

| OPTION CODE | ACTUATOR COLOR |
|-------------|----------------|
| 2 | Black |
| 3 | Red |
| 4 | Orange |
| 5 | Yellow |
| 9 | Gray |

For additional colors please contact Customer Service.

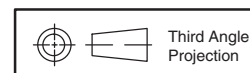

Third Angle
Projection



Dimensions are shown: mm (inches)
Specifications and dimensions subject to change



NP Series Sealed Industrial Pushbutton Switch

HOUSING STYLE

Pushbutton

A

T STANDARD THREADED MOUNT

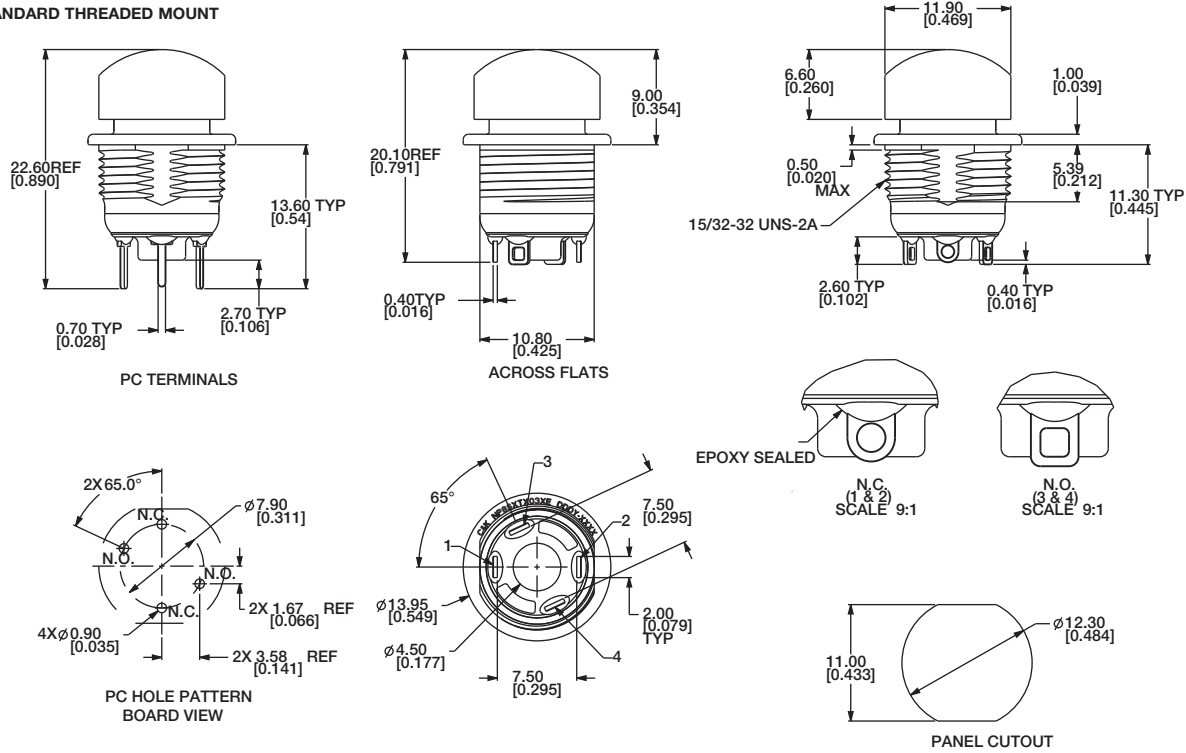

L LONG THREADED MOUNT

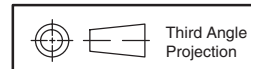
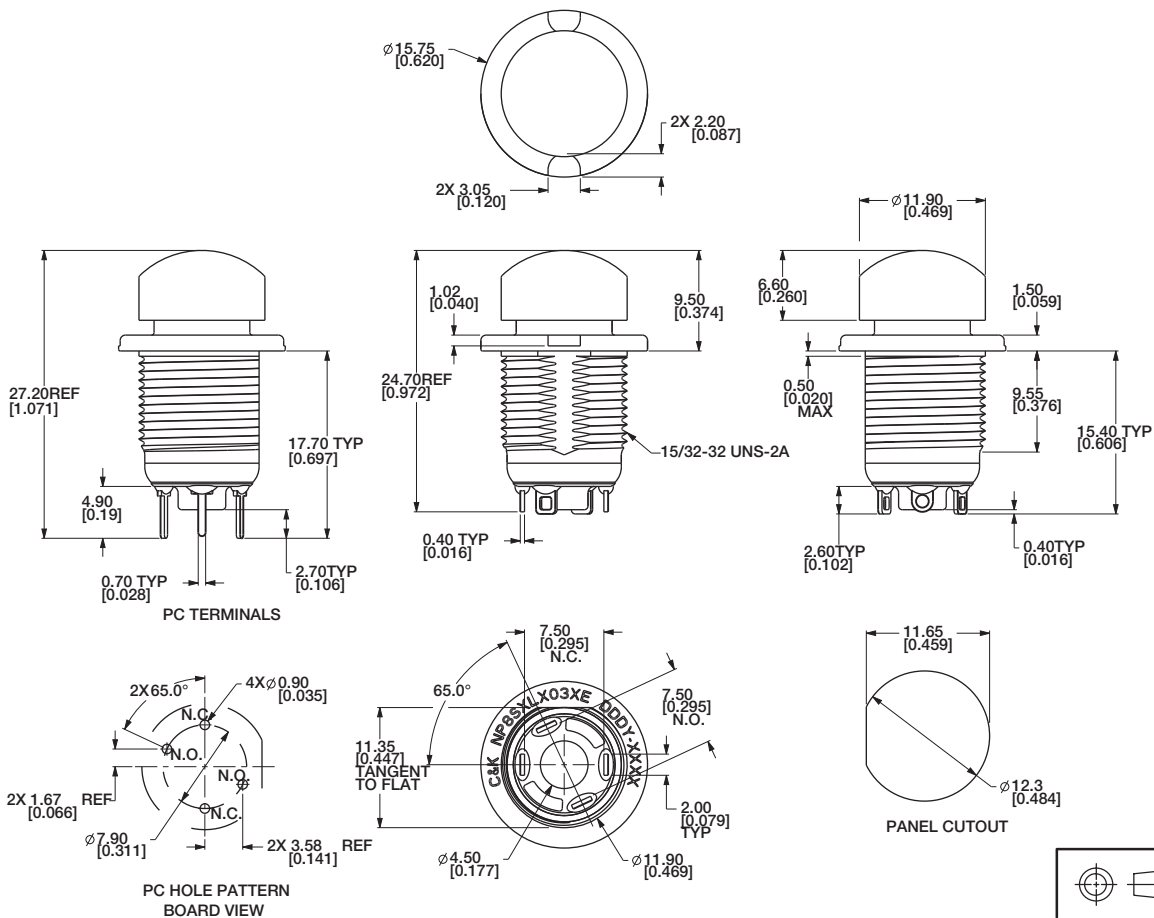

Dimensions are shown: mm (inches)
 Specifications and dimensions subject to change

NP Series Sealed Industrial Pushbutton Switch



A

Pushbutton

HOUSING STYLE

H SHORT THREADED MOUNT

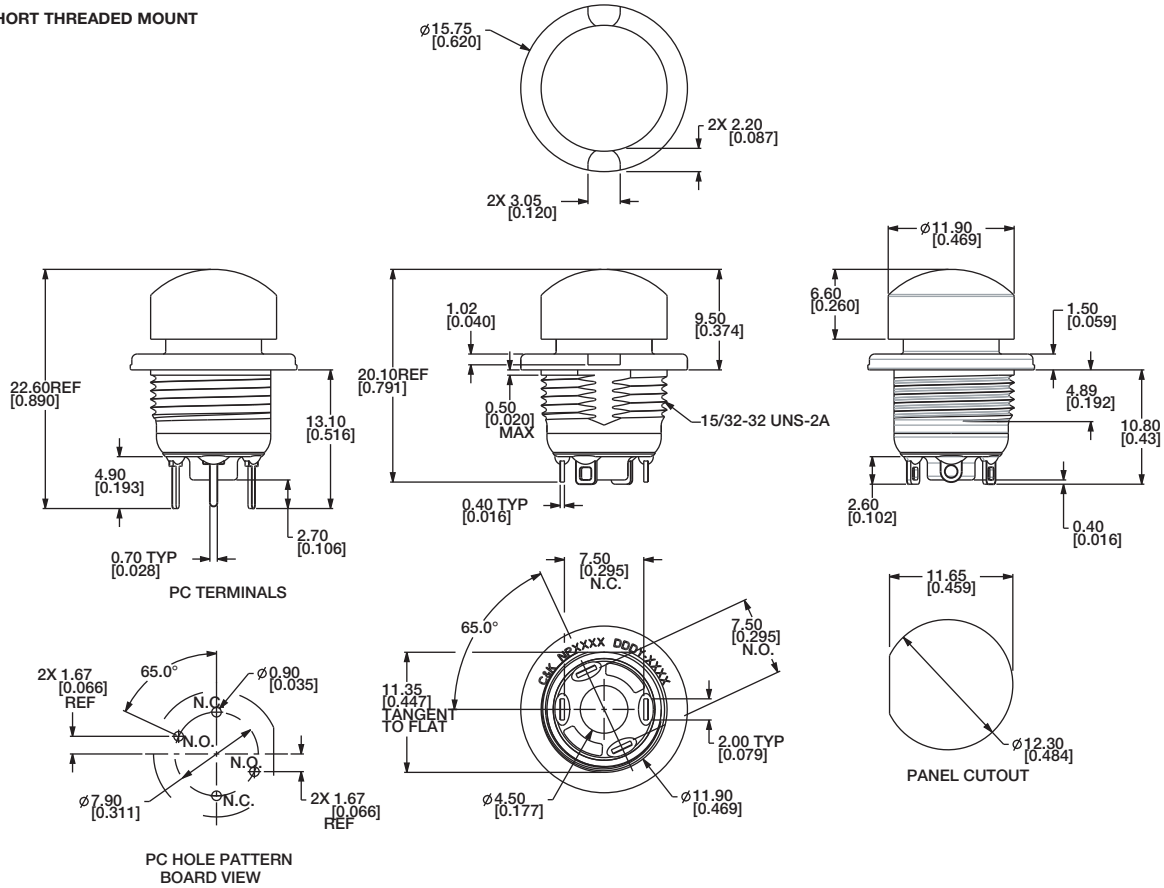

S SLOT MOUNT

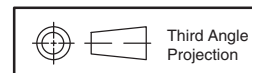
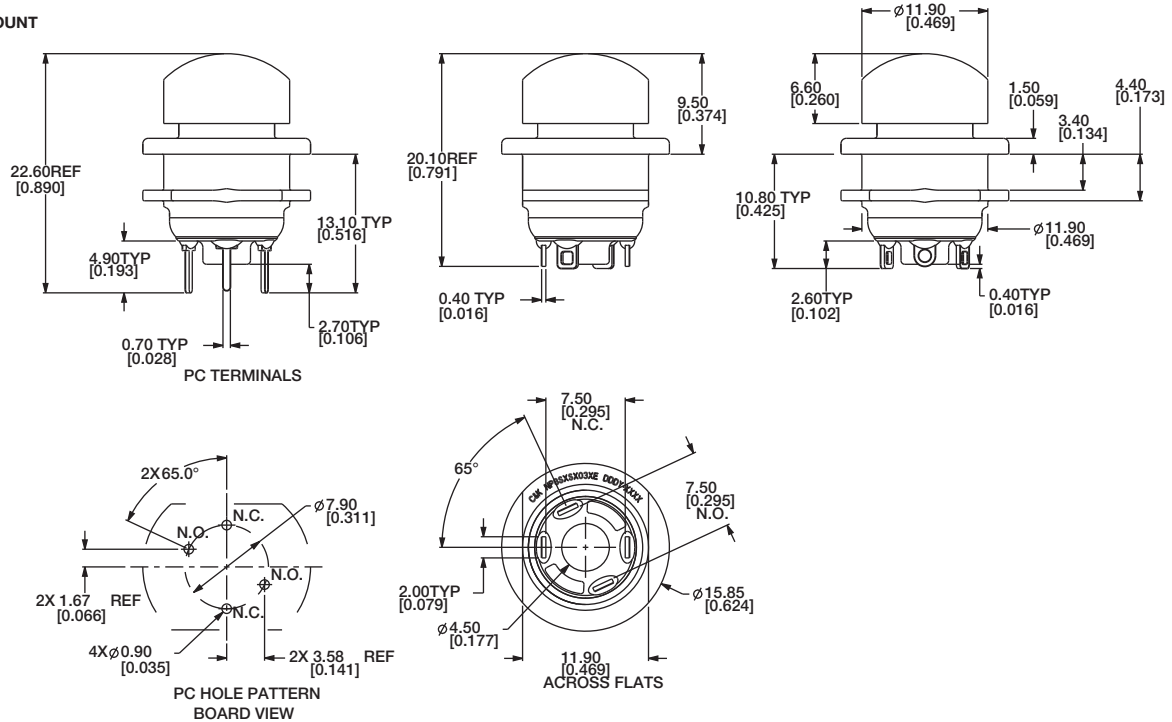

Third Angle
Projection



Dimensions are shown: mm (inches)
Specifications and dimensions subject to change



NP Series Sealed Industrial Pushbutton Switch

HOUSING STYLE

Pushbutton

A

R REAR MOUNT

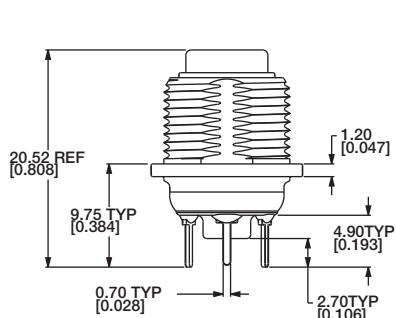
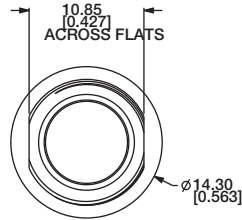

PC TERMINALS

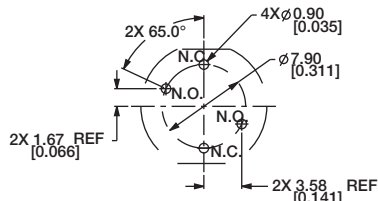

PC HOLE PATTERN
BOARD VIEW

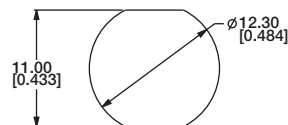
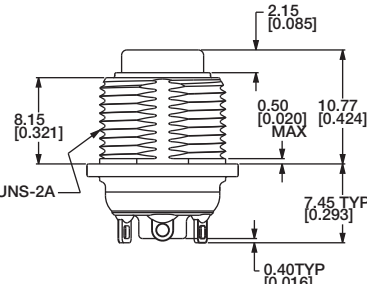
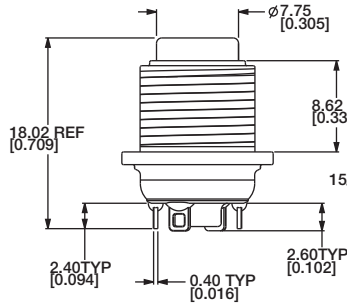

PANEL CUTOUT

D DOME BEZEL

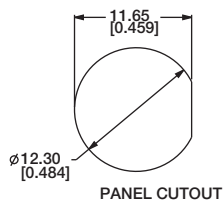

PANEL CUTOUT

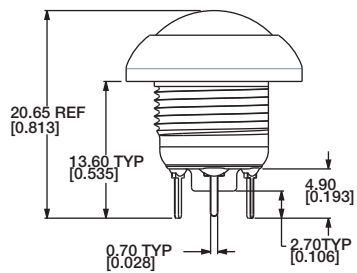
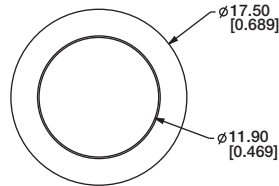

PC TERMINALS

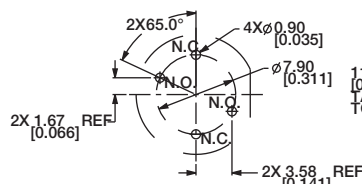

PC HOLE PATTERN
BOARD VIEW

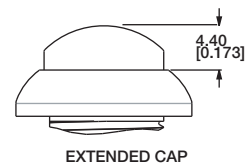
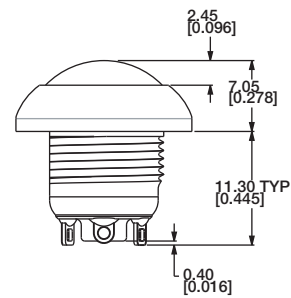
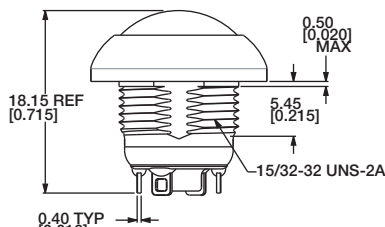

EXTENDED CAP

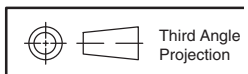
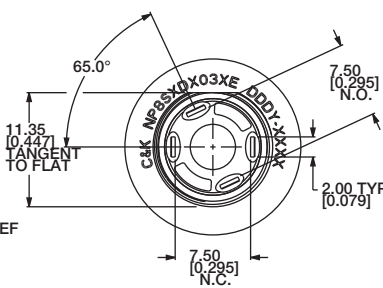

Dimensions are shown: Inches (mm)
Specifications and dimensions subject to change

NP Series Sealed Industrial Pushbutton Switch



A

Pushbutton

HOUSING STYLE

P TAPERED BEZEL

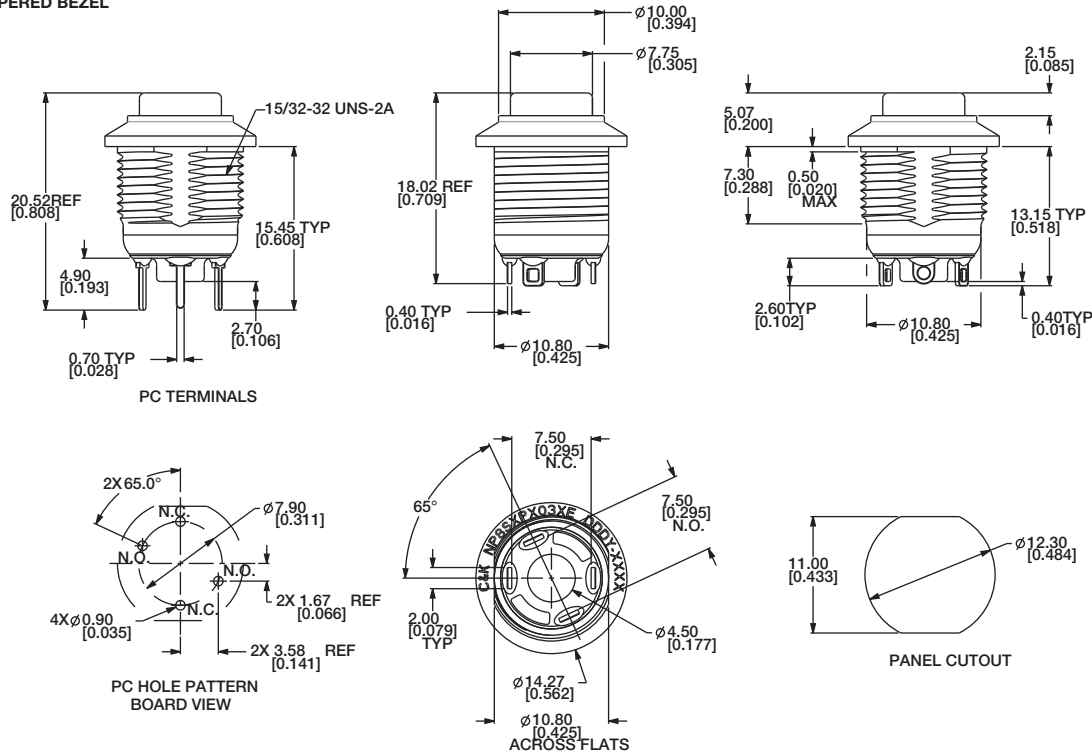

HOUSING ANODIZING COLOR

| OPTION CODE | ANODIZING COLOR |
|-------------|----------------------|
| 1 | Clear anodized |
| 2 | Black anodized (STD) |

TERMINATION

03 SOLDER LUG (STD)

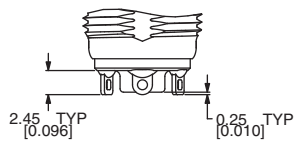

02 PC PIN (G CONTACT MATERIAL)

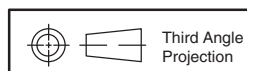
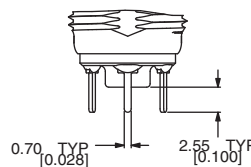

Third Angle
Projection



Dimensions are shown: Inches (mm)
Specifications and dimensions subject to change



NP Series Sealed Industrial Pushbutton Switch

A

Pushbutton

TERMINATION

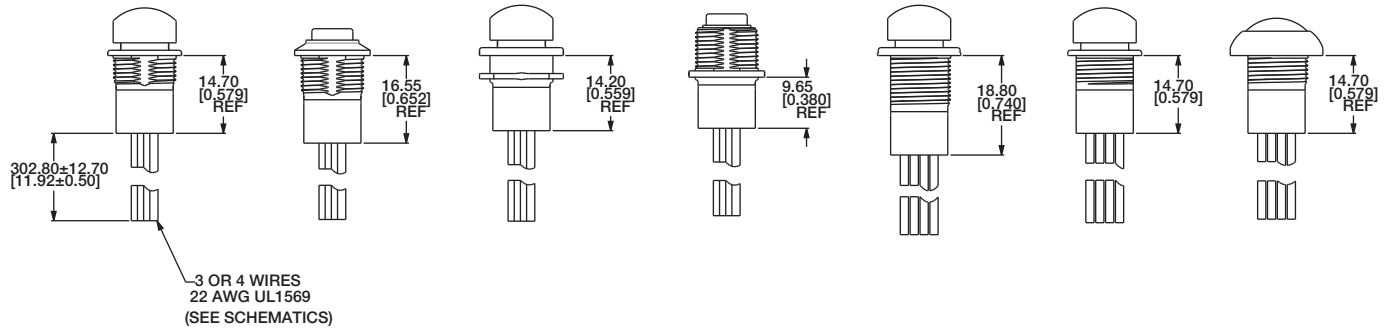

W3 3X 12" 22 AWG UL1569 WIRE (OVERMOLDED)

W4 4X 12" 22 AWG UL1569 WIRE (OVERMOLDED)

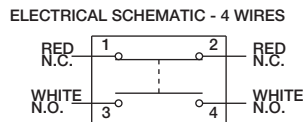
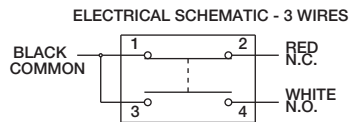

CONTACT MATERIAL

| OPTION CODE | CONTACT MATERIAL |
|-------------|------------------|
| Q | Silver (STD) |
| G | Gold over Silver |

TERMINAL SEAL

E EPOXY

All models are epoxy sealed

HARDWARE

HEX NUT
707100201 Nickel-plated

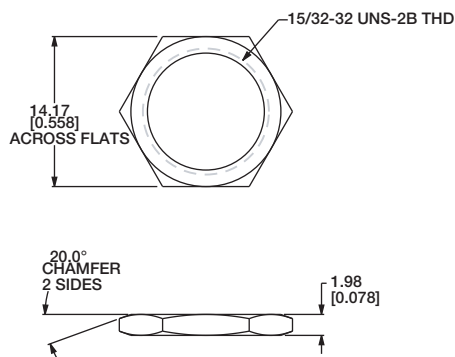

LOCKWASHER
700302202

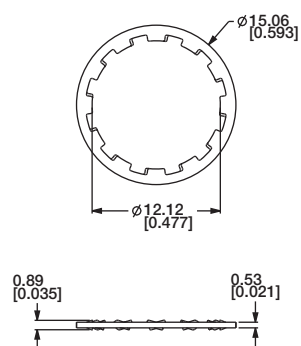

PANEL GASKET
851D02000

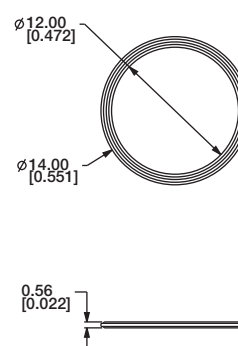

Dimensions are shown: mm (inches)
Specifications and dimensions subject to change

PBA Series Illuminated Pushbutton



A

Pushbutton

Features/Benefits

- Illuminated display
- Small size
- Cold lighting
- Tactile feed back

Typical Applications

- Avionics



Mechanical

ACTUATION FORCE: 5,5 N ± 0,5 N
 MAXIMUM FORCE: 80 N
 TRAVEL TO CONTACT: 1,2 ± 0,1 mm
 OVERTRAVEL: >0,3 mm
 TOTAL TRAVEL: 1,5 ± 0,1 mm
 LIFE EXPECTANCY: 10⁸ operations 28 V - 10 mA
 WEIGHT: 2 grams
 VIBRATION: ± 0,45mm from 33 Hz to 75 Hz
 ACCELERATION: 10 g max

Electrical

CONTACTS: Gold plated
 VOLTAGE: Max 100 V - Min 20 mV DC
 CARRYING CURRENT: Max 250 mA - Min 50 µA
 SWITCHING CURRENT: Max 50 mA - Min 50 µA
 MAX SWITCHING POWER: 1 W
 CONTACT RESISTANCE: < 50 Ω
 DIELECTRIC STRENGTH: 500 V rms
 INSULATION RESISTANCE (100 V): > 5000 M Ω
 BOUNCE: < 3 ms
 SWITCHING OF 2 POLES MATCHING: < 10 ms

Environmental Data

STORAGE TEMPERATURE: -55°C TO 85°C
 OPERATING TEMPERATURE: -30°C TO 85°C
 TEMPERATURE OF KEY TO CAP: < Ambient +25°C
 HUMIDITY TEST: 21 days (-40°C - 93% HR)
 ALTITUDE PRESSURE: From 20 hPa to 1070 hPa

Soldering Data

WAVE SOLDERING: 260°C / 5s
 MANUAL SOLDERING: 350°C / 2s
 SEALING: According to IP64

Plastic Material

Housing and Cap: UL-94 V0

NOTE: Specifications and materials listed above are for switches with standard options. For information on specific and custom switches, please contact Customer Service.

Build-A-Switch

To order, simply select desired option from each category and place in the appropriate box.

Designation **PBA** PBA Series

Size

| | |
|---|-----------|
| 1 | 9,5 x 14 |
| 2 | 11,5 x 14 |
| 3 | 14 x 14 |

Marking Location

| | |
|---|--------|
| H | High |
| M | Middle |
| L | Low |

Type of Marking

| | |
|---|------------------|
| T | Text / Legend |
| S | Status Indicator |

LED Color

| | | |
|---|--------------|----------|
| 0 | White | λ |
| 1 | Green | λ 560 nm |
| 2 | Yellow Green | λ 568 nm |
| 3 | Amber | λ 590 nm |
| 4 | Red | λ 660 nm |
| 5 | Other | λ |

Repeat sequence for 2nd Marking

LED Supply or Type

| | |
|----|----------------------|
| AC | Alternative |
| DC | Direct |
| XX | for each marking |
| | 1:6 LEDs in parallel |
| | for direct current |

Display Type

| | | LED Non-Illuminated | LED Illuminated |
|---|--------------|---------------------|-----------------|
| N | Text Marking | White | LED Color |
| | Background | Black | Black |
| S | Text Marking | Not visible | LED Color |
| | Background | Black | Black |
| R | Text Marking | White | LED Color |
| | Background | Red | Red |
| G | Text Marking | Green | Green |
| | Background | Black | Black |





PBA Series Illuminated Pushbutton

A

Pushbutton

LIGHTING DATA

The legends of function and the status indicator can be illuminated separately.

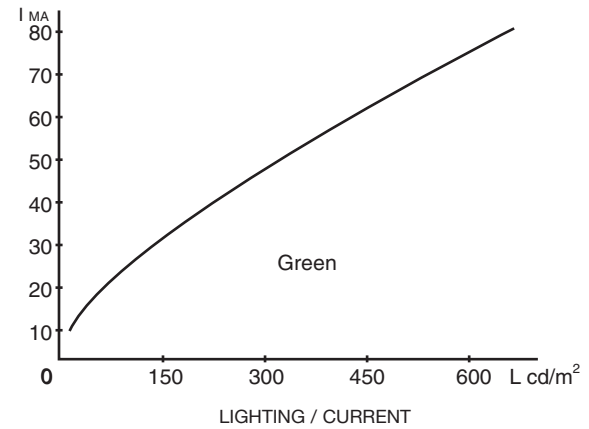
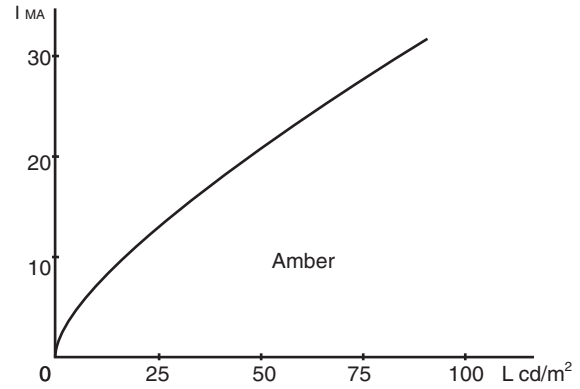

| Color | Amber | Green |
|---------------|---------------|------------------------------------|
| Wave Length | 586 < λ < 592 | 555 < λ < 560 |
| Current Max | 80 mA | 80 mA |
| Chromaticity | X Y | 0,54 < X < 0,58 0,40 < Y < 0,44 |
| Contrast Min. | 1,2 | 0,85 |

For other colors and displays, please contact Customer Service.

DIMENSIONS (applicable for any size)

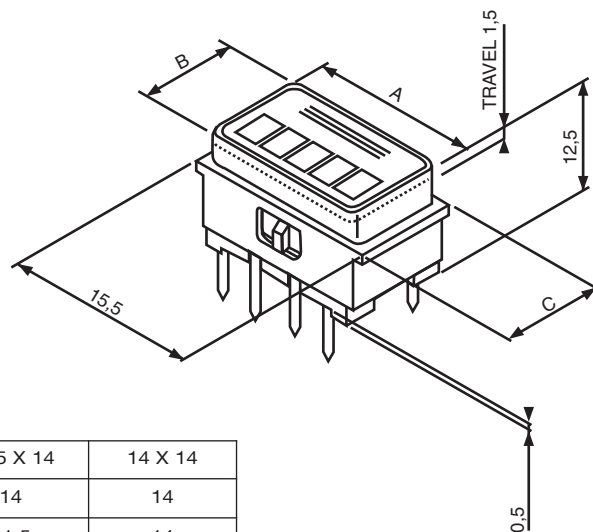
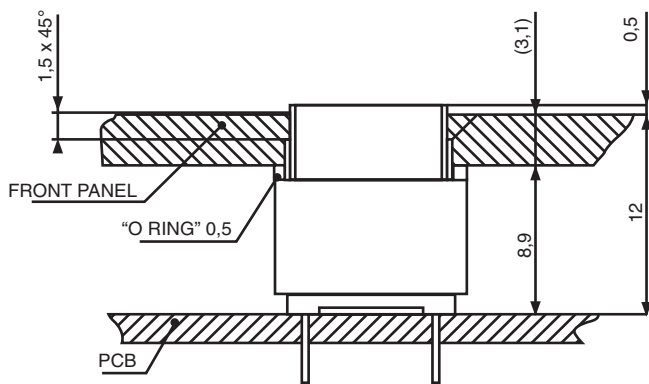

| | 9,5 X 14 | 11,5 X 14 | 14 X 14 |
|---|----------|-----------|---------|
| A | 14 | 14 | 14 |
| B | 9,5 | 11,5 | 14 |
| C | 11 | 11,5 | 15,5 |

Tolerance: ± 0,1 mm



Dimensions are shown: mm
Specifications and dimensions subject to change

PBA Series Illuminated Pushbutton



A
Pushbutton

LED MODULE LAYOUT

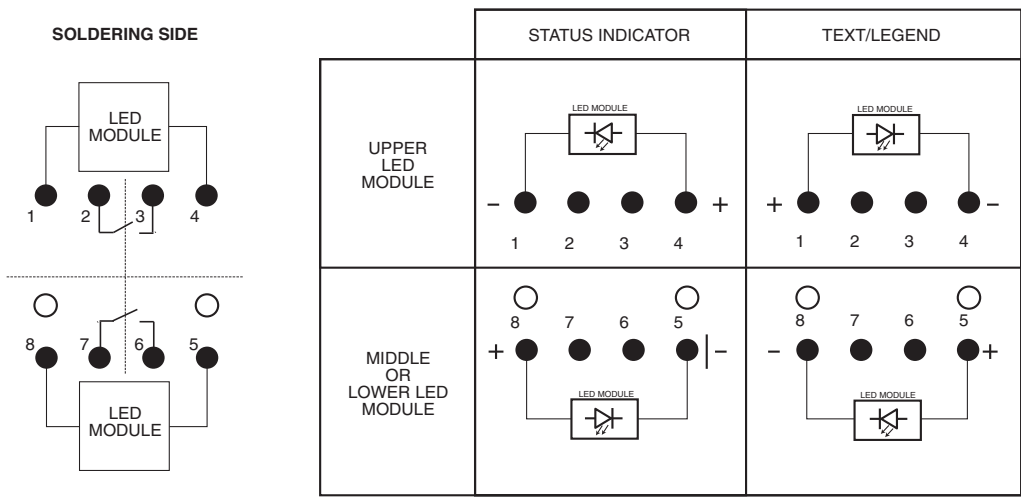

PCB Layout

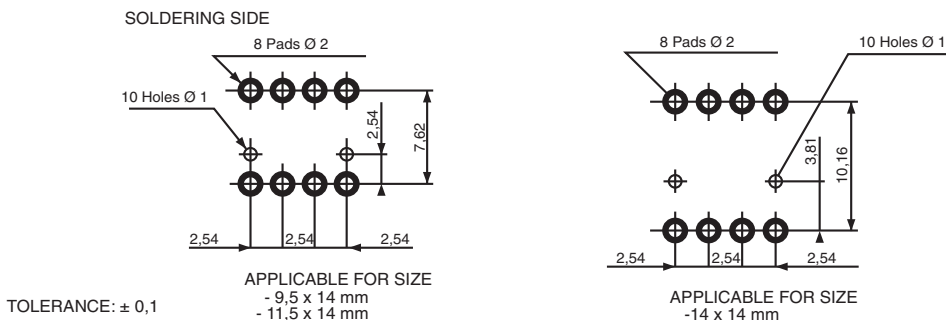

TACTILE EFFECT

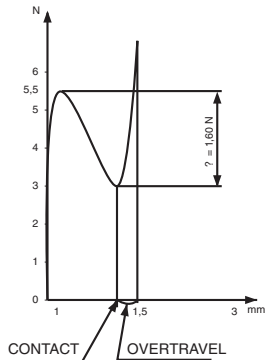

- TRAVEL**
- TRAVEL TO CONTACT: $1,2 \pm 0,1 \text{ mm}$
 - OVERTRAVEL: $> 0,3 \text{ mm}$
 - TOTAL TRAVEL: $1,5 \pm 0,1 \text{ mm}$
- FORCE**
- ACTUATOR FORCE: $5,5 \text{ N} \pm 0,5 \text{ N}$
 - TACTILE FEELING: $1,6 \text{ N}$

1 or 2 markings are available in any combination of text / legend or status indicator.

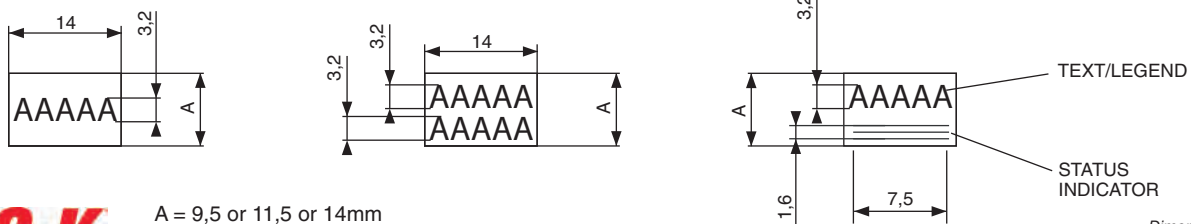

A = 9,5 or 11,5 or 14mm

Dimensions are shown: mm
Specifications and dimensions subject to change



A

Pushbutton



*Dimensions are shown: mm
Specifications and dimensions subject to change*

PB Series Single Pole and Multi-Key Pushbutton Switches



A

Pushbutton

Features/Benefits

- Momentary or latching options
- Reliable contact design
- 2, 4, and 6 pole configurations
- Long travel and extended life cycles

Typical Applications

- Appliances
- Audio and visual equipment
- Consumer electronics
- Industrial equipment



Specifications

CONTACT RATING: 0.3A @ 30 VDC
 INITIAL CONTACT RESISTANCE: 30 m ohms max.
 INSULATION RESISTANCE: 100 M ohms min.
 DIELECTRIC STRENGTH: 500 V AC (50-60 Hz) between open terminals and between the frame and terminal.
 OPERATING LIFE: 10,000 cycles without load
 OPERATING FORCE:
 250 ± 100 gf (2.45 ± 0.98N)
 LOCK TRAVEL: 2 ± 0.3 mm
 TOTAL TRAVEL: 3 ± 0.3 mm
 OPERATING TEMPERATURE: -20°C to 70°C

Materials

CASE: PC (UL 94HB)
 PLASTIC CLIP: POM (UL 94HB)
 SPRING: SUS
 KNOB: POM
 TERMINAL: Silver plated

PB-22D01-L 2PDT LOCK / LATCHING

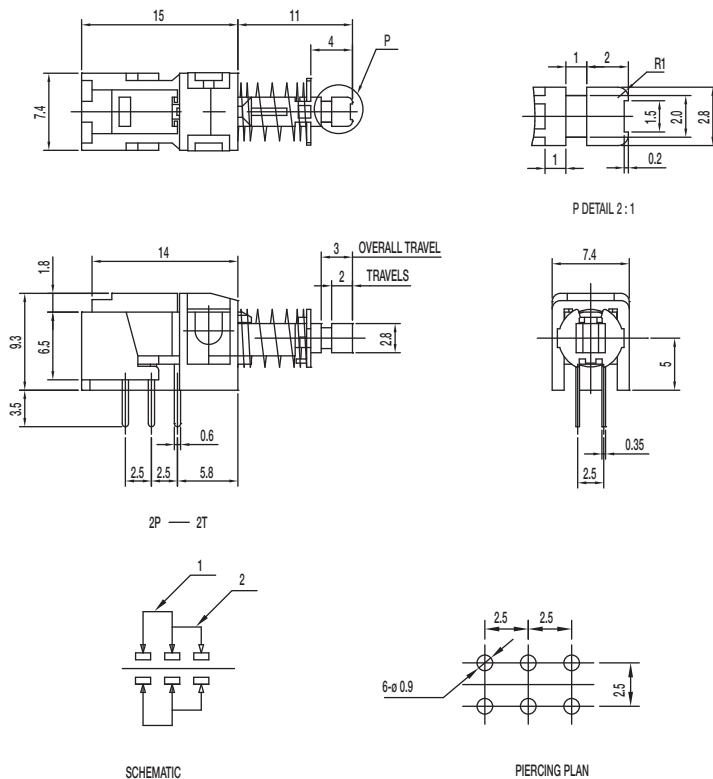

Dimensions are shown: mm
 Specifications and dimensions subject to change



PB Series Single Pole and Multi-Key Pushbutton Switches

PB-42D01-L 4PDT LOCK / LATCHING

Pushbutton
A

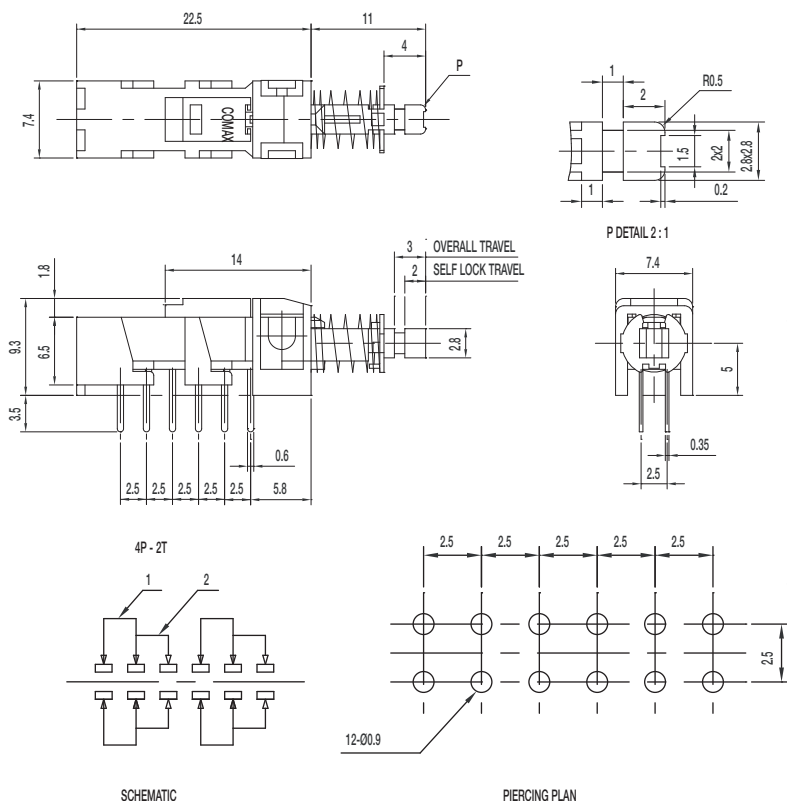

Specifications

CONTACT RATING: 0.3A @ 30 VDC
 INITIAL CONTACT RESISTANCE: 30 m ohms max.
 INSULATION RESISTANCE: 100 M ohms min.
 DIELECTRIC STRENGTH: 500 V AC (50-60 Hz) between open terminals and between the frame and terminal.
 OPERATING LIFE: 10,000 cycles without load
 OPERATING FORCE:
 280 ± 100 gf
 LOCK TRAVEL: 2 ± 0.3 mm
 TOTAL TRAVEL: 3 ± 0.3 mm
 OPERATING TEMPERATURE: -20°C to 70°C

Materials

CASE: PC (UL 94HB)
 PLASTIC CLIP: POM (UL 94HB)
 SPRING: SUS
 KNOB: POM
 TERMINAL: Silver plated

PB-62D01-L 6PDT LOCK / LATCHING

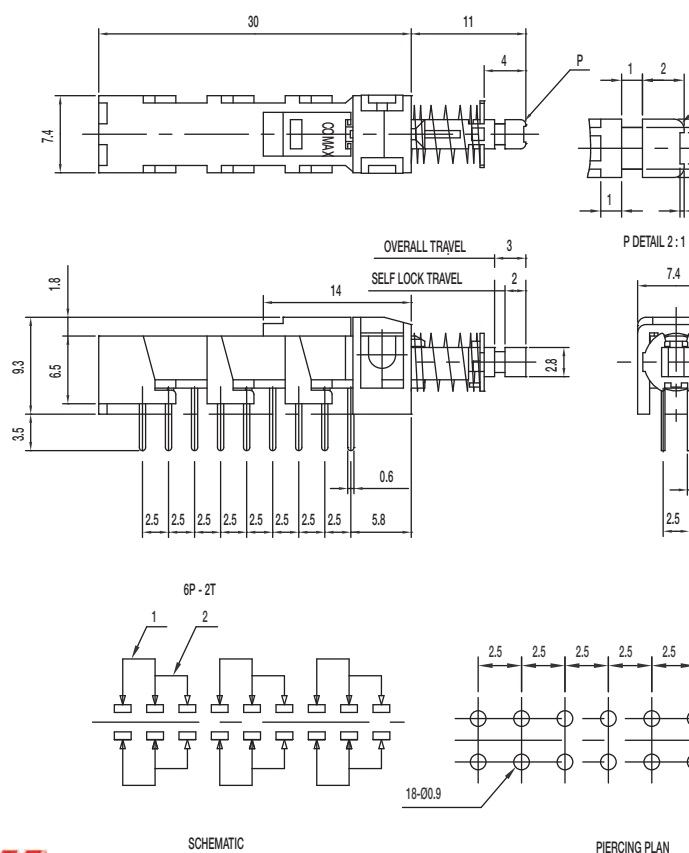

Specifications

CONTACT RATING: 0.3A @ 30 VDC
 INITIAL CONTACT RESISTANCE: 30 m ohms max.
 INSULATION RESISTANCE: 100 M ohms min.
 DIELECTRIC STRENGTH: 500 V AC (50-60 Hz) between open terminals and between the frame and terminal.
 OPERATING LIFE: 10,000 cycles without load
 OPERATING FORCE:
 300 ± 100 gf ($2.94 \pm 0.98\text{N}$)
 LOCK TRAVEL: 2 ± 0.3 mm
 TOTAL TRAVEL: 3 ± 0.3 mm
 OPERATING TEMPERATURE: -20°C to 70°C

Materials

CASE: PC (UL 94HB)
 PLASTIC CLIP: POM (UL 94HB)
 SPRING: SUS
 KNOB: POM
 TERMINAL: Silver plated



*Dimensions are shown: mm
 Specifications and dimensions subject to change*

PB Series Single Pole and Multi-Key Pushbutton Switches



A

Pushbutton

PB-22D01-F 2PDT NON-LOCK / MOMENTARY

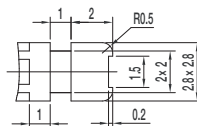
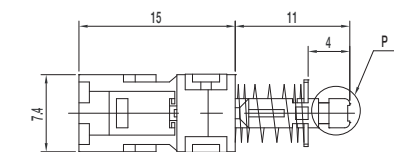

P DETAIL 2:1

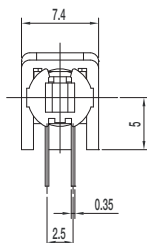
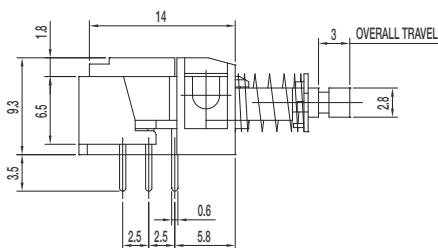

2P — 2T

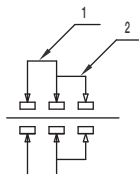

SCHEMATIC

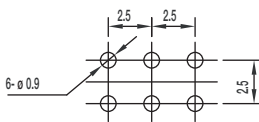

PIERCING PLAN

Specifications

CONTACT RATING: 0.3A @ 30 VDC
 INITIAL CONTACT RESISTANCE: 30 m ohms max.
 INSULATION RESISTANCE: 100 M ohms min.
 DIELECTRIC STRENGTH: 500 V AC (50-60 Hz) between open terminals and between the frame and terminal.
 OPERATING LIFE: 10,000 cycles without load
 OPERATING FORCE:
 250 ± 100 gf (2.45 ± 0.98 N)
 TOTAL TRAVEL: 3 ± 0.3 mm
 OPERATING TEMPERATURE: -20°C to 70°C

Materials

CASE: PC (UL 94HB)
 PLASTIC CLIP: POM (UL 94HB)
 SPRING: SUS
 KNOB: POM
 TERMINAL: Silver plated

PB-42D01-F 4PDT NON-LOCK / MOMENTARY

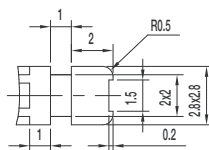
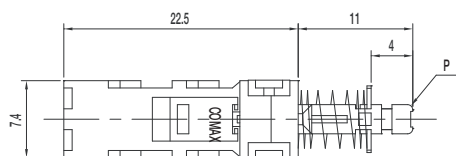

P DETAIL 2:1

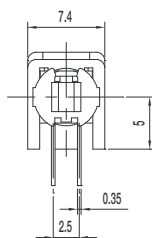
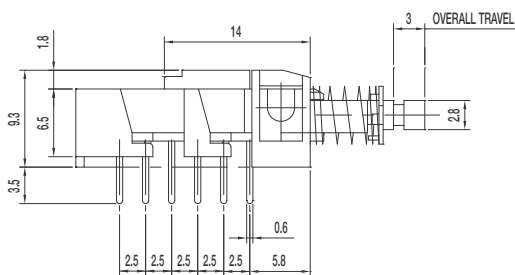

4P - 2T

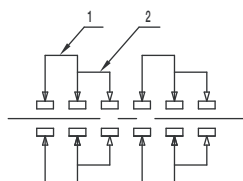

SCHEMATIC

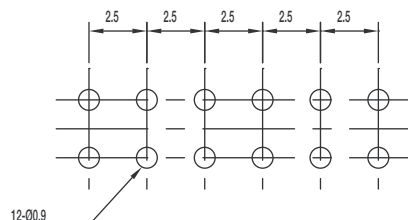

PIERCING PLAN

Specifications

CONTACT RATING: 0.3A @ 30 VDC
 INITIAL CONTACT RESISTANCE: 30 m ohms max.
 INSULATION RESISTANCE: 100 M ohms min.
 DIELECTRIC STRENGTH: 500 V AC (50-60 Hz) between open terminals and between the frame and terminal.
 OPERATING LIFE: 10,000 cycles without load
 OPERATING FORCE:
 280 ± 100 gf (2.477 ± 0.98 N)
 TOTAL TRAVEL: 3 ± 0.3 mm
 OPERATING TEMPERATURE: -20°C to 70°C

Materials

CASE: PC (UL 94HB)
 PLASTIC CLIP: POM (UL 94HB)
 SPRING: SUS
 KNOB: POM
 TERMINAL: Silver plated



Dimensions are shown: mm
 Specifications and dimensions subject to change



PB Series Single Pole and Multi-Key Pushbutton Switches

PB-62D01-F 6PDT NON-LOCK / MOMENTARY

Pushbutton
A

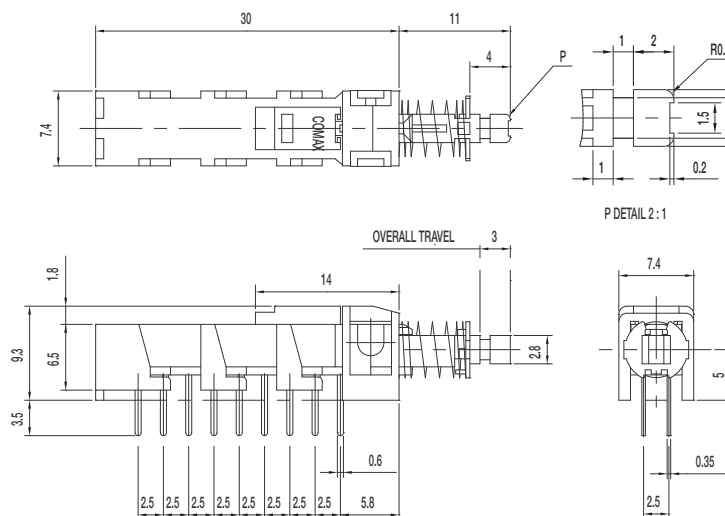

Specifications

- CONTACT RATING: 0.3A @ 30 VDC
- INITIAL CONTACT RESISTANCE: 30 m ohms max.
- INSULATION RESISTANCE: 100 M ohms min.
- DIELECTRIC STRENGTH: 500 V AC (50-60 Hz) between open terminals and between the frame and terminal.
- OPERATING LIFE: 10,000 cycles without load
- OPERATING FORCE:
300 ± 100 gf (2.94 ± 0.98N)
- TOTAL TRAVEL: 3 ± 0.3 mm
- OPERATING TEMPERATURE: -20°C to 70°C

Materials

- CASE: PC (UL 94HB)
- PLASTIC CLIP: POM (UL 94HB)
- SPRING: SUS
- KNOB: POM
- TERMINAL: Silver plated

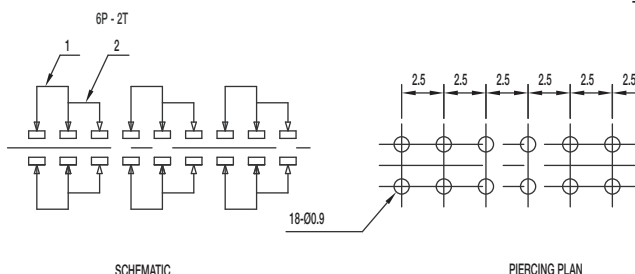

SCHEMATIC

PIERCING PLAN

PB-22G02-L 2PDT LOCK / LATCHING

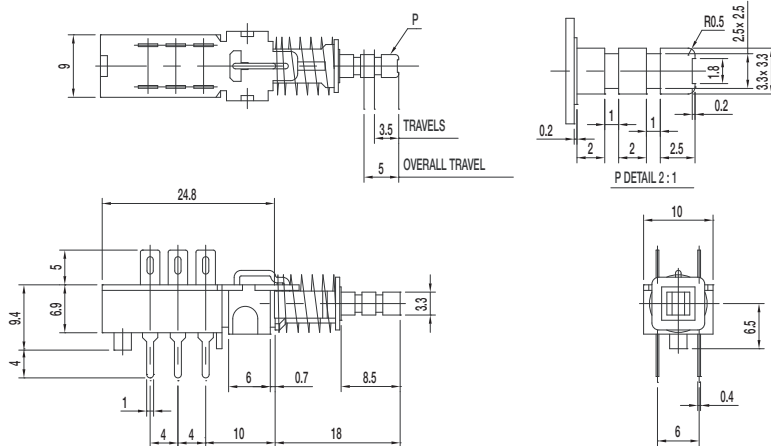

Specifications

- CONTACT RATING: 1A @ 25 VDC
- INITIAL CONTACT RESISTANCE: 30 m ohms max.
- INSULATION RESISTANCE: 100 M ohms min.
- DIELECTRIC STRENGTH: 500 V AC (50-60 Hz) between open terminals and between the frame and terminal.
- OPERATING LIFE: 10,000 cycles without load
- OPERATING FORCE:
350 ± 150 gf (3.43 ± 1.47N)
- LOCK TRAVEL: 3.5 ± 0.3mm
- TOTAL TRAVEL: 5 ± 0.3 mm
- OPERATING TEMPERATURE: -20°C to 70°C

Materials

- CASE: PC (UL 94HB)
- SPRING: SUS
- KNOB: POM
- TERMINAL: Silver plated

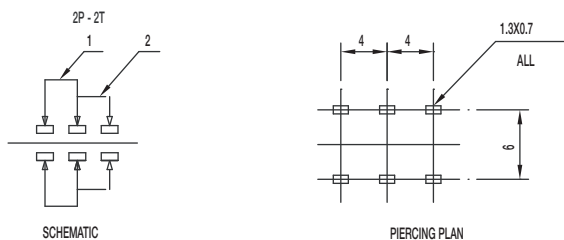

SCHEMATIC

PIERCING PLAN



Dimensions are shown: mm
Specifications and dimensions subject to change

PB Series Single Pole and Multi-Key Pushbutton Switches



A

Pushbutton

PB-42G02-L 4PDT LOCK / LATCHING

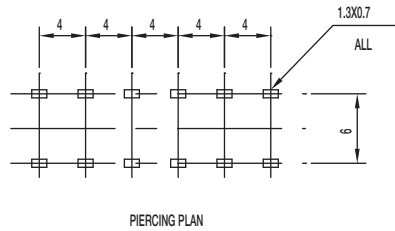
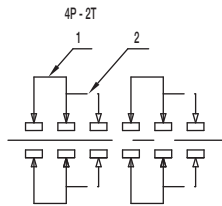
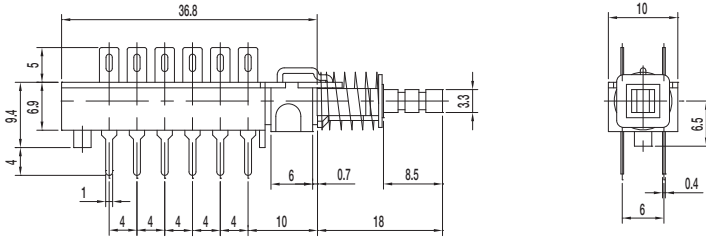
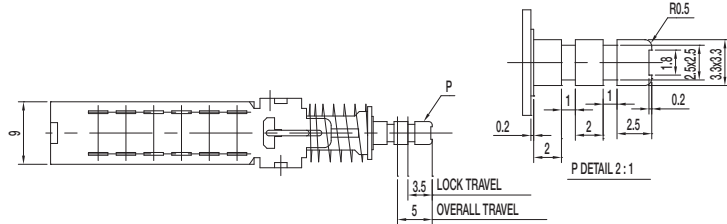

Specifications

- CONTACT RATING: 1A @ 25 VDC
- INITIAL CONTACT RESISTANCE: 30 m ohms max.
- INSULATION RESISTANCE: 100 M ohms min.
- DIELECTRIC STRENGTH: 500 V AC (50-60 Hz) between open terminals and between the frame and terminal.
- OPERATING LIFE: 10,000 cycles without load
- OPERATING FORCE:
400 ± 150 gf (3.92 ± 1.47N)
- LOCK TRAVEL: 3.5 ± 0.3mm
- TOTAL TRAVEL: 5 ± 0.3 mm
- OPERATING TEMPERATURE: -20°C to 70°C

Materials

- HOUSING: PC (UL 94HB)
- SPRING: SUS
- KNOB: POM
- TERMINAL: Silver plated

PB-62G02-L DPDT LOCK / LATCHING

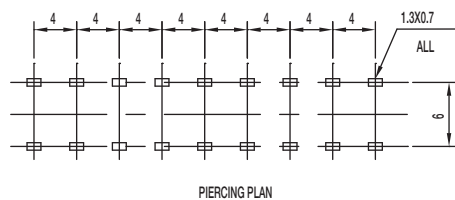
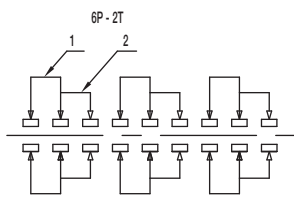
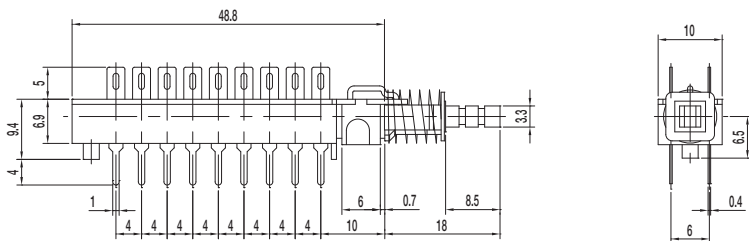
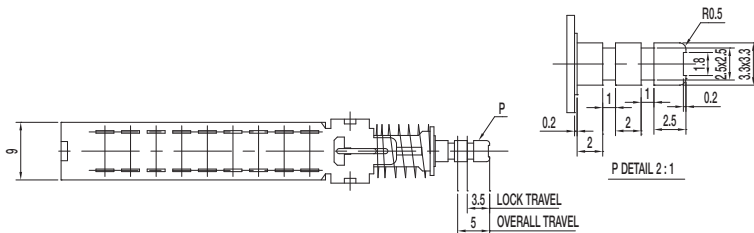

Specifications

- CONTACT RATING: 1A @ 25 VDC
- INITIAL CONTACT RESISTANCE: 30 m ohms max.
- INSULATION RESISTANCE: 100 M ohms min.
- DIELECTRIC STRENGTH: 500 V AC (50-60 Hz) between open terminals and between the frame and terminal.
- OPERATING LIFE: 10,000 cycles without load
- OPERATING FORCE:
450 ± 150 gf
- LOCK TRAVEL: 3.5 ± 0.3mm
- TOTAL TRAVEL: 5 ± 0.3 mm
- OPERATING TEMPERATURE: -20°C to 70°C

Materials

- HOUSING: PC (UL 94HB)
- SPRING: SUS
- KNOB: POM
- TERMINAL: Silver plated



Dimensions are shown: mm
Specifications and dimensions subject to change



PB Series Single Pole and Multi-Key Pushbutton Switches

PB-22G02-F DPDT NON-LOCK / MOMENTARY

Pushbutton
A

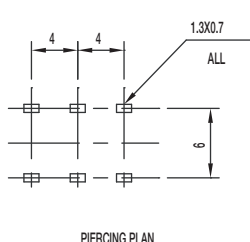
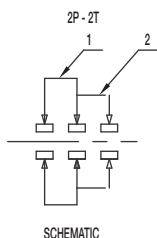
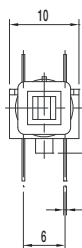
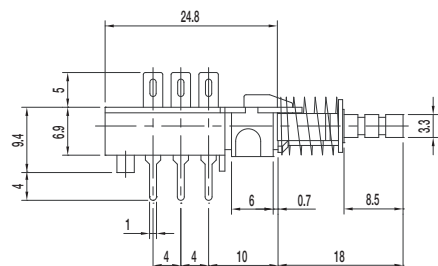
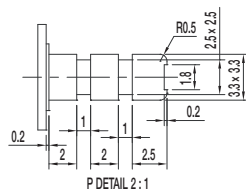
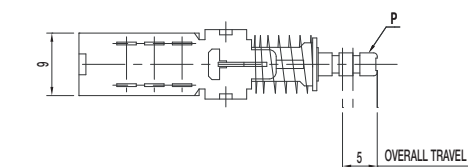

Specifications

CONTACT RATING: 1A @ 25 VDC
 INITIAL CONTACT RESISTANCE: 30 m ohms max.
 INSULATION RESISTANCE: 100 M ohms min.
 DIELECTRIC STRENGTH: 500 V AC (50-60 Hz) between open terminals and between the frame and terminal.
 OPERATING LIFE: 10,000 cycles without load
 OPERATING FORCE:
 350 ± 150 gf (3.43 ± 1.47N)
 TOTAL TRAVEL: 5 ± 0.3 mm
 OPERATING TEMPERATURE: -20°C to 70°C

Materials

CASE: PC (UL 94HB)
 SPRING: SUS
 KNOB: POM
 TERMINAL: Silver plated

PB-42G02-F 4PDT NON-LOCK / MOMENTARY

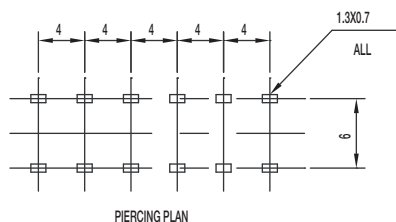
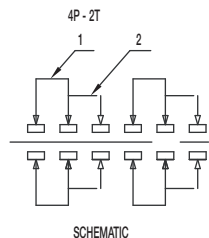
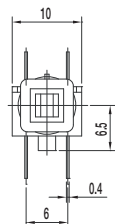
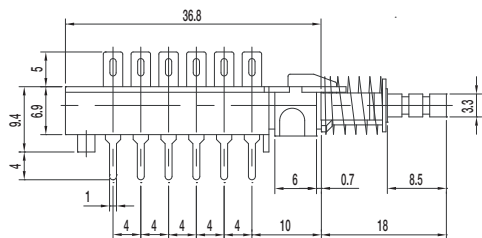
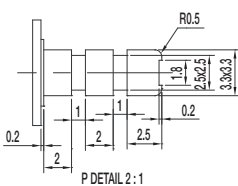
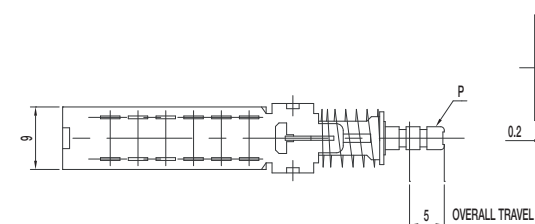

Specifications

CONTACT RATING: 1A @ 25 VDC
 INITIAL CONTACT RESISTANCE: 30 m ohms max.
 INSULATION RESISTANCE: 100 M ohms min.
 DIELECTRIC STRENGTH: 500 V AC (50-60 Hz) between open terminals and between the frame and terminal.
 OPERATING LIFE: 10,000 cycles without load
 OPERATING FORCE:
 400 ± 150 gf (3.92 ± 1.47N)
 TOTAL TRAVEL: 5 ± 0.3 mm
 OPERATING TEMPERATURE: -20°C to 70°C

Materials

HOUSING: PC (UL 94HB)
 SPRING: SUS
 KNOB: POM
 TERMINAL: Silver plated



Dimensions are shown: mm
 Specifications and dimensions subject to change

PB Series Single Pole and Multi-Key Pushbutton Switches



A

Pushbutton

PB-62G02-F 6PDT NON-LOCK / MOMENTARY

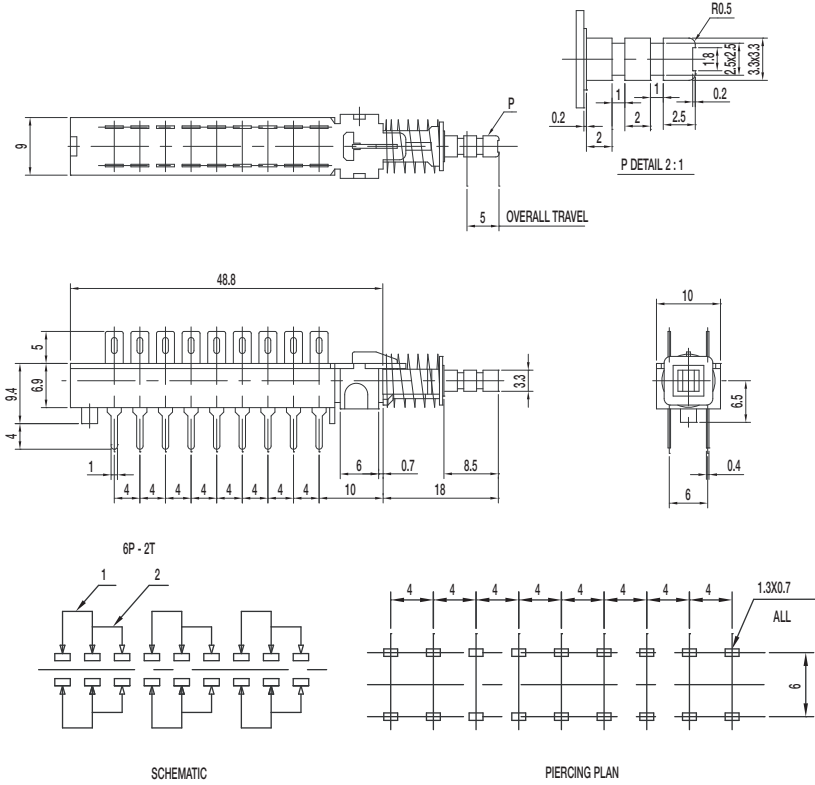

Specifications

- CONTACT RATING: 1A @ 25 VDC
- INITIAL CONTACT RESISTANCE: 30 m ohms max.
- INSULATION RESISTANCE: 100 M ohms min.
- DIELECTRIC STRENGTH: 500 V AC (50-60 Hz) between open terminals and between the frame and terminal.
- OPERATING LIFE: 10,000 cycles without load
- OPERATING FORCE: 450 ± 150 gf (4.41 ± 1.47N)
- TOTAL TRAVEL: 5 ± 0.3 mm
- OPERATING TEMPERATURE: -20°C to 70°C

Materials

- HOUSING: PC (UL 94HB)
- SPRING: SUS
- KNOB: POM
- TERMINAL: Silver plated

PB Multi-Key Series

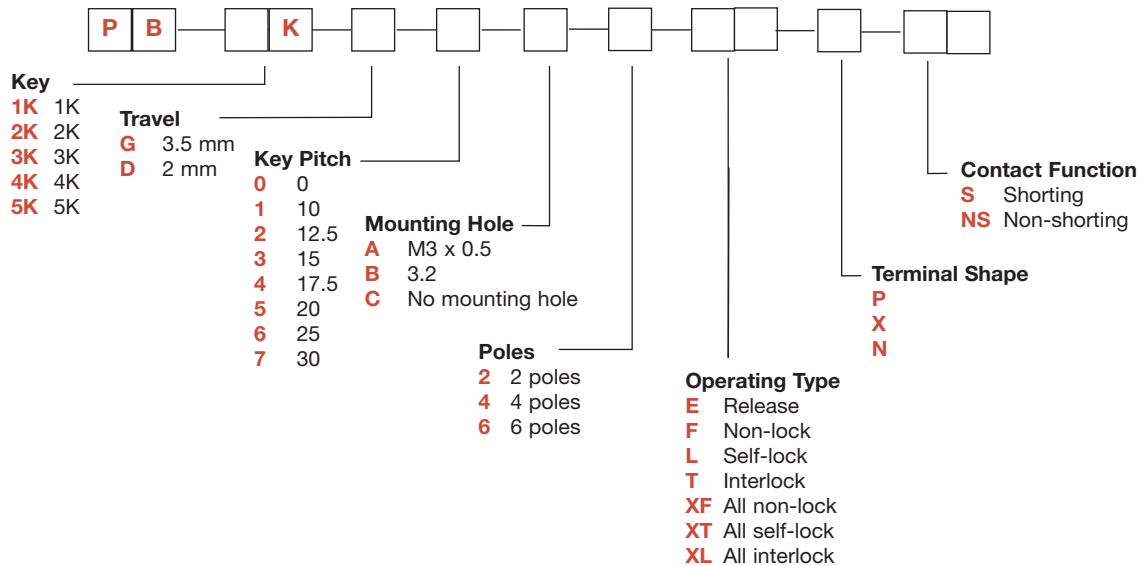

Dimensions are shown: mm
Specifications and dimensions subject to change



PB Series Single Pole and Multi-Key Pushbutton Switches

A

PB Multi-Key Series

Pushbutton

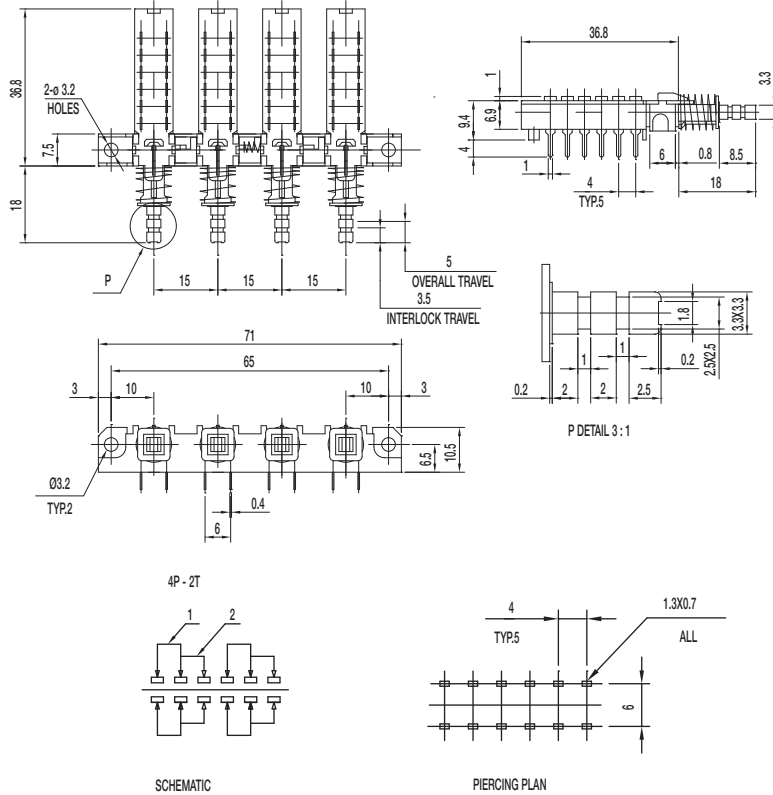

Specifications

CONTACT RATING: 0.3A @ 30 VDC
 INITIAL CONTACT RESISTANCE: 30 m ohms max.
 INSULATION RESISTANCE: 100 M ohms min.
 DIELECTRIC STRENGTH: 500 V AC (50-60 Hz) between open terminals and between the frame and terminal.
 OPERATING LIFE: 10,000 cycles without load
 OPERATING FORCE:
 250 ± 100 gf (2.45 ± 0.98N)
 TOTAL TRAVEL: 3 ± 0.3 mm
 OPERATING TEMPERATURE: -20°C to 70°C

Materials

CASE: PC (UL 94HB)
 PLASTIC CLIP: POM (UL 94HB)
 SPRING: SUS
 KNOB: POM
 TERMINAL: Silver plated



Dimensions are shown: mm
 Specifications and dimensions subject to change

PS-12G Series Pushbutton Switches



A

Pushbutton

Features/Benefits

- Latching pushbutton
- Non-shorting with lock
- 5 mm travel
- SPDT

Typical Applications

- Automotive interior lighting
- Computer peripherals
- Appliances



| PART NUMBER | PACKAGING | SCHEMATIC |
|-----------------|------------|-----------|
| PS-12G01 | 200 pieces | |

Dimensions

FOOTPRINT: 14 X 16.8 mm

HEIGHT: 18 mm

Specifications

CONTACT RATING: 1A @ 14 VDC

INITIAL CONTACT RESISTANCE: 100 m ohms max.

INSULATION RESISTANCE: 100 M ohms min.

DIELECTRIC STRENGTH: 500 V AC (50-60 Hz) between open terminals and between the frame and terminal.

OPERATING LIFE: 20,000 cycles with load

OPERATING FORCE: 400 ± 100 gf

OPERATING POSITION: 3.6 ± 0.2 mm

TOTAL TRAVEL: 5 ± 0.3 mm

OPERATING TEMPERATURE: -20°C to 70°C

Materials

KNOB: POM (UL 94HB)

HOUSING: PBT (UL 94V-0)

COVER: PBT (UL 94V-0)

ROTOR: PBT (UL 94V-0)

SLIDER: POM (UL 94HB)

TERMINAL: Phospher bronze, silver plated

SPRING: Stainless steel

CONTACT: Phospher bronze, silver plated

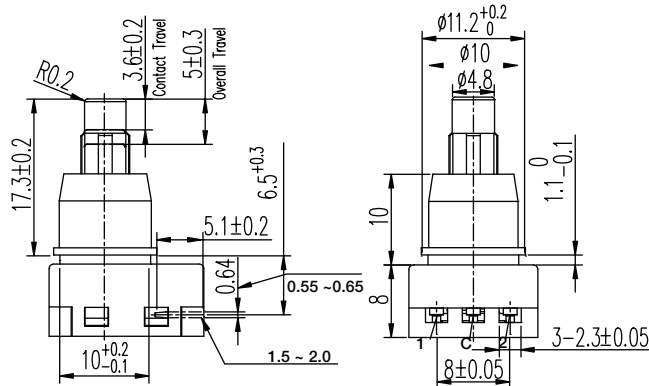
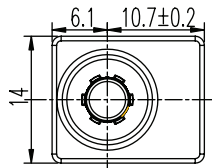



PS-12G Series Pushbutton Switches

Pushbutton
A



| PART NUMBER | PACKAGING | SCHEMATIC |
|-----------------|------------|-----------|
| PS-12G03 | 200 pieces | |

Dimensions

FOOTPRINT: 14 X 16.8 mm

HEIGHT: 18.3 mm

Specifications

CONTACT RATING: 2.2A @ 14.5 VDC

INITIAL CONTACT RESISTANCE: 50 m ohms max.

INSULATION RESISTANCE: 100 M ohms min.

DIELECTRIC STRENGTH: 500 V AC (50-60 Hz) between open terminals and between the frame and terminal.

OPERATING LIFE: 20,000 cycles with load

OPERATING FORCE: 650 ± 300 gf

OPERATING POSITION: 4.00 ± 0.2 mm

TOTAL TRAVEL: 4.5 ± 0.3 mm

OPERATING TEMPERATURE: -40°C to 85°C

Materials

KNOB: POM (UL 94HB)

HOUSING: PBT & PA (UL 94V-0)

COVER: PBT (UL 94V-0)

ROTOR: PBT (UL 94V-0)

SLIDER: POM (UL 94HB)

TERMINAL: Brass, silver plated

SPRING: Stainless steel

CONTACT: Phosphor bronze, silver plated

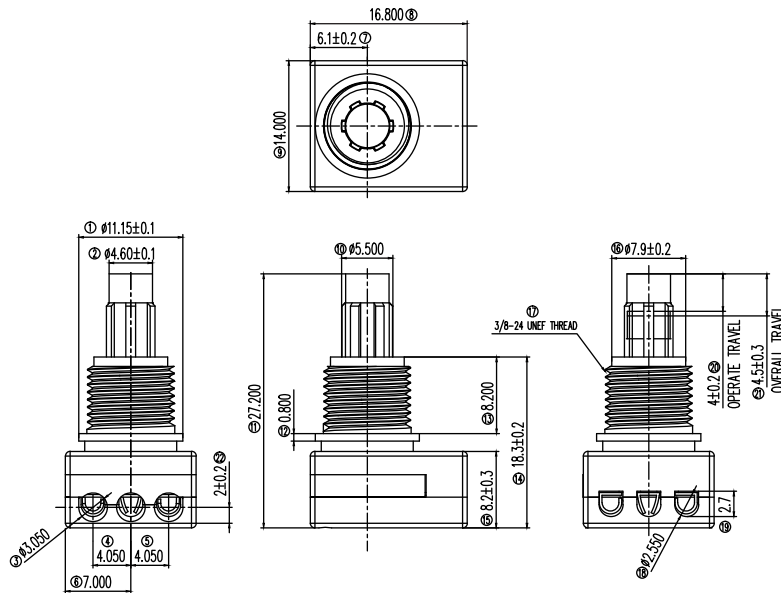

TYCO .062 Commercial Pin
and Socket Connector
PT# 770983-1



Dimensions are shown: mm
Specifications and dimensions subject to change

PS-22 Series Subminiature Pushbutton Switches



A

Pushbutton

Features/Benefits

- Compact miniature push switch
- Momentary or latching options
- Shorting or non-shorting
- DPDT

Typical Applications

- Industrial
- Automotive
- Audio and visual equipment



| PART NUMBER | PACKAGING | SCHEMATIC |
|------------------------|--------------|-----------|
| PS-2203-L NS PA | 1,000 pieces | |
| PS-2203-F NS PA | 1,000 pieces | |

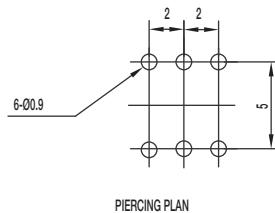
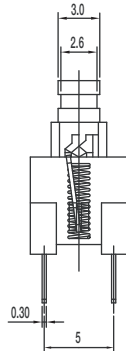
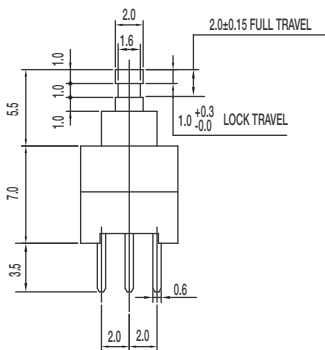
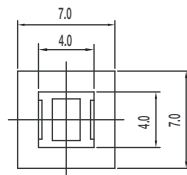

Dimensions

FOOTPRINT: 7.0 x 7.0 mm

HEIGHT: 12.5 mm

Specifications

CONTACT RATING: 0.1A @ 30 VDC

INITIAL CONTACT RESISTANCE: 30 m ohms max.

INSULATION RESISTANCE: 100 M ohms min.

DIELECTRIC STRENGTH: 500 V AC (50-60 Hz) between open terminals and between the frame and terminal.

OPERATING LIFE: 10,000 cycles with load

OPERATING FORCE:

200 ± 100 gf (1.96 ± 0.98N)

LOCK TRAVEL: 1 mm

TOTAL TRAVEL: 2 mm

OPERATING TEMPERATURE: -20°C to 70°C

Materials

KNOB: POM Black

HOUSING: PA Black

COVER: POM Grey (latch) / White (Mom)

TERMINAL: Brass, silver plated

CONTACT CLIP: Phosphor bronze, silver plated

SPRING: Stainless steel

HOOK LOCK: Stainless steel (latch)



PS-22 Series Subminiature Pushbutton Switches

Pushbutton
A



| PART NUMBER | PACKAGING | SCHEMATIC |
|------------------------|--------------|-----------|
| PS-2206-L NS PA | 1,000 pieces | |
| PS-2206-F NS PA | 1,000 pieces | |

Dimensions

FOOTPRINT: 8.0 x 8.0 mm

HEIGHT: 13.5 mm

Specifications

CONTACT RATING: 0.1A @ 30 VDC

INITIAL CONTACT RESISTANCE: 70 m ohms max.

INSULATION RESISTANCE: 100 M ohms min.

DIELECTRIC STRENGTH: 500 V AC (50-60 Hz) between open terminals and between the frame and terminal.

OPERATING LIFE: 10,000 cycles with load

OPERATING FORCE:
200 ± 100 gf (1.96 ± 0.98N)

LOCK TRAVEL: 1.5 mm

TOTAL TRAVEL: 2.5 mm

OPERATING TEMPERATURE: -20°C to 70°C

Materials

KNOB: POM Black

HOUSING: PA Black

COVER: POM Grey (latch) / White (Mom)

TERMINAL: Brass, silver plated

CONTACT CLIP: Phosphor bronze., silver plated

SPRING: Stainless steel

HOOK LOCK: Stainless steel (latch)

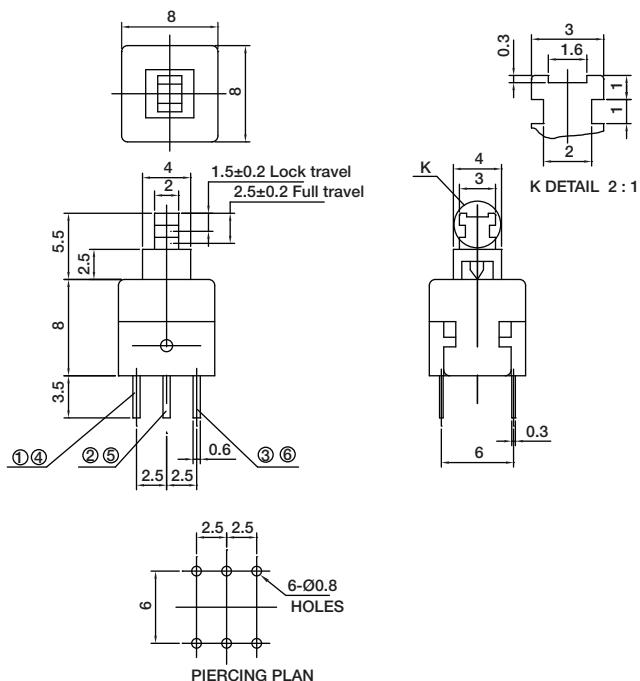

| PART NUMBER | PACKAGING | SCHEMATIC |
|------------------------|--------------|-----------|
| PS-2214-L NS PA | 1,000 pieces | |
| PS-2214-F NS PA | 1,000 pieces | |

Dimensions

FOOTPRINT: 5.8 x 5.8 mm

HEIGHT: 7.5 mm

Specifications

CONTACT RATING: 0.1A @ 30 VDC

INITIAL CONTACT RESISTANCE: 80 m ohms max.

INSULATION RESISTANCE: 100 M ohms min.

DIELECTRIC STRENGTH: 500 V AC (50-60 Hz) between open terminals and between the frame and terminal.

OPERATING LIFE: 10,000 cycles with load

OPERATING FORCE:
150 ± 50 gf (1.47 ± 0.49N)

LOCK TRAVEL: 1.45 mm

TOTAL TRAVEL: 2.3 mm

OPERATING TEMPERATURE: -20°C to 70°C

Materials

KNOB: POM Natural (latch) / PA black

HOUSING: PA Black

COVER: PA Black

TERMINAL: Brass, silver plated

CONTACT CLIP: Phosphor bronze, silver clad

SPRING: Stainless steel

HOOK LOCK: Stainless steel (latch)

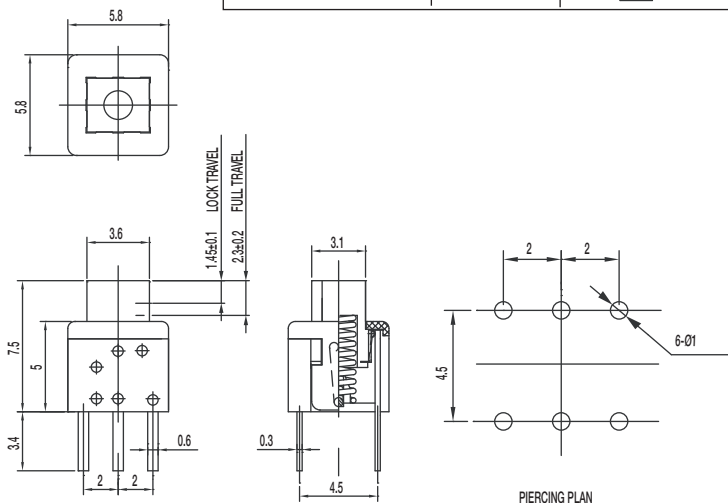

*Dimensions are shown: mm
Specifications and dimensions subject to change*

PS-22 Series Subminiature Pushbutton Switches



A

Pushbutton



| PART NUMBER | PACKAGING | SCHEMATIC |
|-----------------------|--------------|-----------|
| PS-221605-L NS | 1,000 pieces | |
| PS-221605-F NS | 1,000 pieces | |

Dimensions

FOOTPRINT: 5.8 x 5.8 mm

HEIGHT: 10 mm

Specifications

CONTACT RATING: 0.1A @ 30 VDC / 2A @ 2 VDC

INITIAL CONTACT RESISTANCE: 80 m ohms max.

INSULATION RESISTANCE: 100 M ohms min.

DIELECTRIC STRENGTH: 500 V AC (50-60 Hz) between open terminals and between the frame and terminal.

OPERATING LIFE: 10,000 cycles with load

OPERATING FORCE:

150 ± 50 gf (1.47 ± 0.49N)

LOCK TRAVEL: 1.3 mm

TOTAL TRAVEL: 2.1 mm

OPERATING TEMPERATURE: -20°C to 70°C

Materials

KNOB: POM Natural

HOUSING: PA Black

COVER: PC Grey

TERMINAL: Bras, silver plated

CONTACT CLIP: Phosphor bronze, silver clad

SPRING: Stainless steel

HOOK LOCK: Stainless steel (latch)

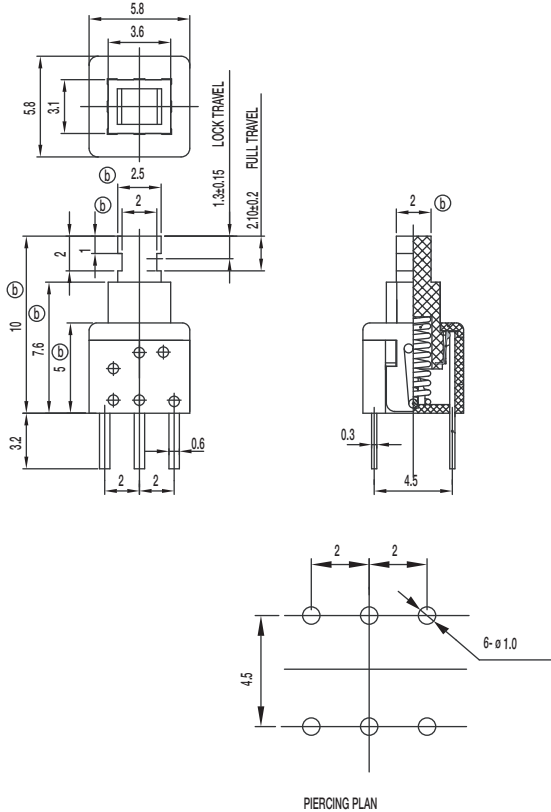



PS Series Miniature Pushbutton Switches

Pushbutton
A



Features/Benefits

- Miniature size
- Momentary or latching options
- Broad range of products

Typical Applications

- Industrial
- Automotive
- Audio and visual equipment
- Telecommunications

PS-22105 DPDT NON-SHORTING

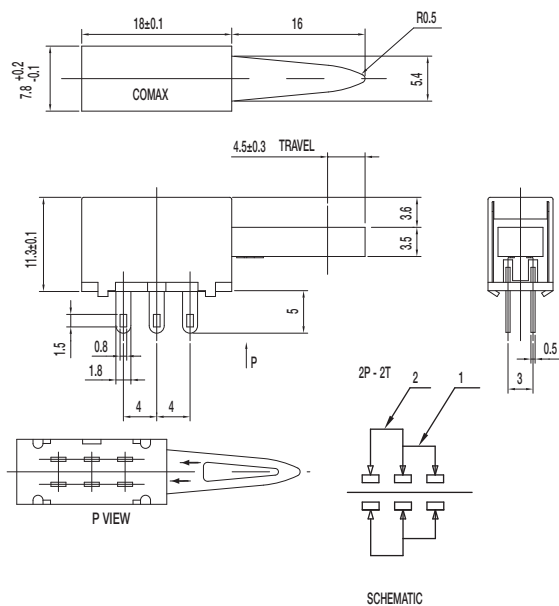

Specifications

CONTACT RATING: 0.3A @ 30 VDC
 INITIAL CONTACT RESISTANCE: 30 m ohms max.
 INSULATION RESISTANCE: 100 M ohms min.
 DIELECTRIC STRENGTH: 500 V AC (50-60 Hz) between open terminals and between the frame and terminal.
 OPERATING LIFE: 10,000 cycles with load
 OPERATING FORCE: 400 ± 150 gf (3.92 ± 1.47N)
 TOTAL TRAVEL: 4.5 ± 0.3 mm
 OPERATING TEMPERATURE: -20°C to 70°C

Materials

FRAME: SECC
 KNOB: POM (UL 94HB)
 CONTACT PLATE: Silver clad
 SPRING: SUS
 TERMINAL: Silver plated

PS-12C02-F NS SPST NON-SHORTING

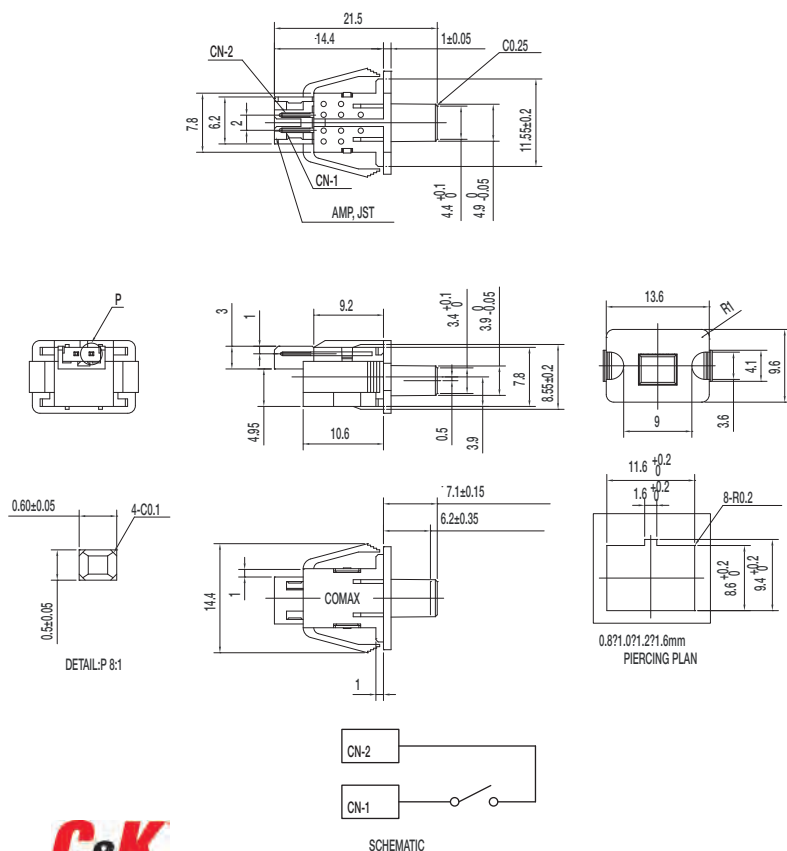

Specifications

CONTACT RATING: 100 μ A @ 3 VDC min. / 10mA @ 5 VDC max
 INITIAL CONTACT RESISTANCE: 100 m ohms max.
 INSULATION RESISTANCE: 100 M ohms min.
 DIELECTRIC STRENGTH: 250 V AC (50-60 Hz) between open terminals and between the frame and terminal.
 OPERATING LIFE: 100,000 cycles with load
 OPERATING FORCE: 50 ± 15 gf (0.49 ± 0.147N)
 PRE-TRAVEL: 6.20 ± 0.35 mm
 OPERATING TEMPERATURE: -40°C to 85°C

Materials

KNOB: POM (UL 94HB)
 COVER: PA (UL 94V-0)
 HOUSING: PA (UL 94V-0)
 SPRING: SUS
 TERMINAL: Silver plated



Dimensions are shown: mm
 Specifications and dimensions subject to change

PS Series Miniature Pushbutton Switches



A

Pushbutton

PS-32C02-F NS 1P3T NON-SHORTING

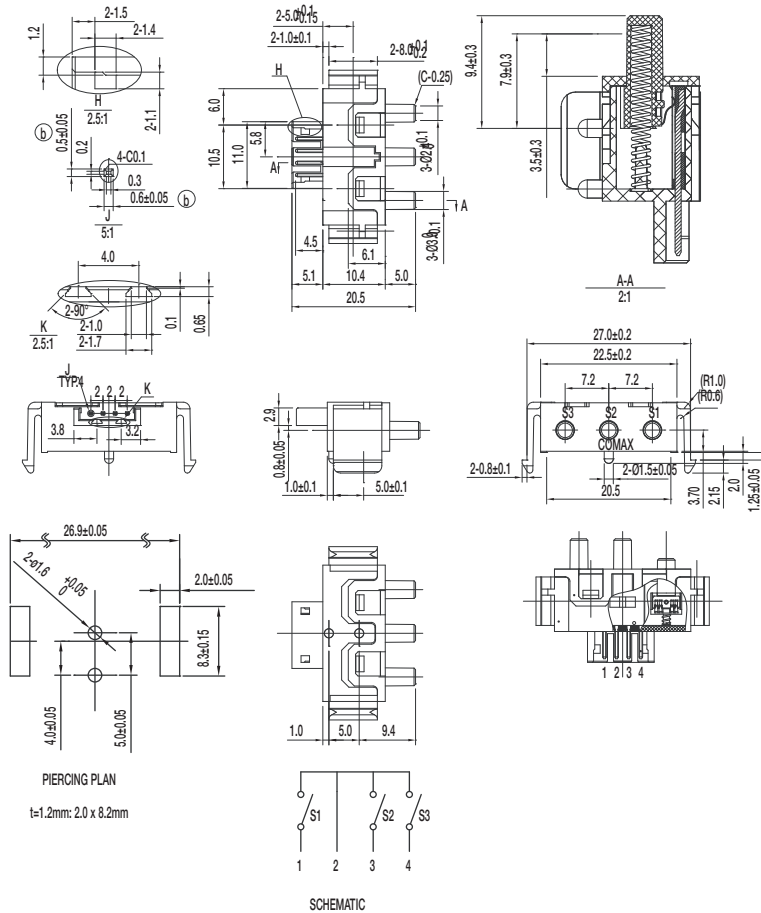

PS-42C02-F NS 1P4T NON-SHORTING

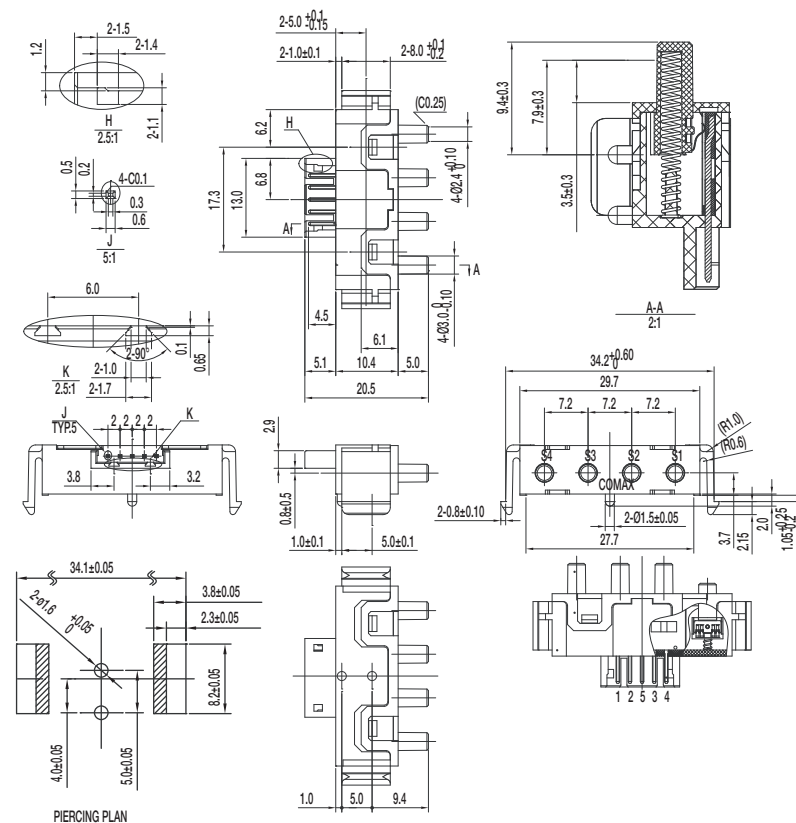

Specifications

- CONTACT RATING: 100 μ A @ 3 VDC min. / 10mA @ 5 VDC max
- INITIAL CONTACT RESISTANCE: 100 m ohms max.
- INSULATION RESISTANCE: 100 M ohms min.
- DIELECTRIC STRENGTH: 250 V AC (50-60 Hz) between open terminals and between the frame and terminal.
- OPERATING LIFE: 100,000 cycles with load
- OPERATING FORCE: 80 \pm 20 gf (0.784 \pm 0.196N)
- PRE-TRAVEL: 1.5 \pm 0.3 mm
- OVER-TRAVEL: 3.5 \pm 0.3 mm
- TOTAL TRAVEL: 5 \pm 0.3 mm
- OPERATING TEMPERATURE: -20°C to 65°C

Materials

- KNOB: POM (UL 94HB)
- COVER: PA (UL 94V-0)
- HOUSING: PA (UL 94V-0)
- SPRING: SUS
- TERMINAL: Silver plated

Specifications

- CONTACT RATING: 100 μ A @ 3 VDC min. / 10mA @ 5 VDC max
- INITIAL CONTACT RESISTANCE: 100 m ohms max.
- INSULATION RESISTANCE: 100 M ohms min.
- DIELECTRIC STRENGTH: 250 V AC (50-60 Hz) between open terminals and between the frame and terminal.
- OPERATING LIFE: 100,000 cycles with load
- OPERATING FORCE: 80 \pm 20 gf (0.784 \pm 0.196N)
- PRE-TRAVEL: 1.5 \pm 0.3 mm
- OVER-TRAVEL: 3.5 \pm 0.3 mm
- TOTAL TRAVEL: 5 \pm 0.3 mm
- OPERATING TEMPERATURE: -20°C to 65°C

Materials

- KNOB: POM (UL 94HB)
- COVER: PA (UL 94V-0)
- HOUSING: PA (UL 94V-0)
- SPRING: SUS
- TERMINAL: Silver plated

Dimensions are shown: mm
Specifications and dimensions subject to change



PS Series Miniature Pushbutton Switches

PS-22C08-G10 NS DPDT NON-SHORTING

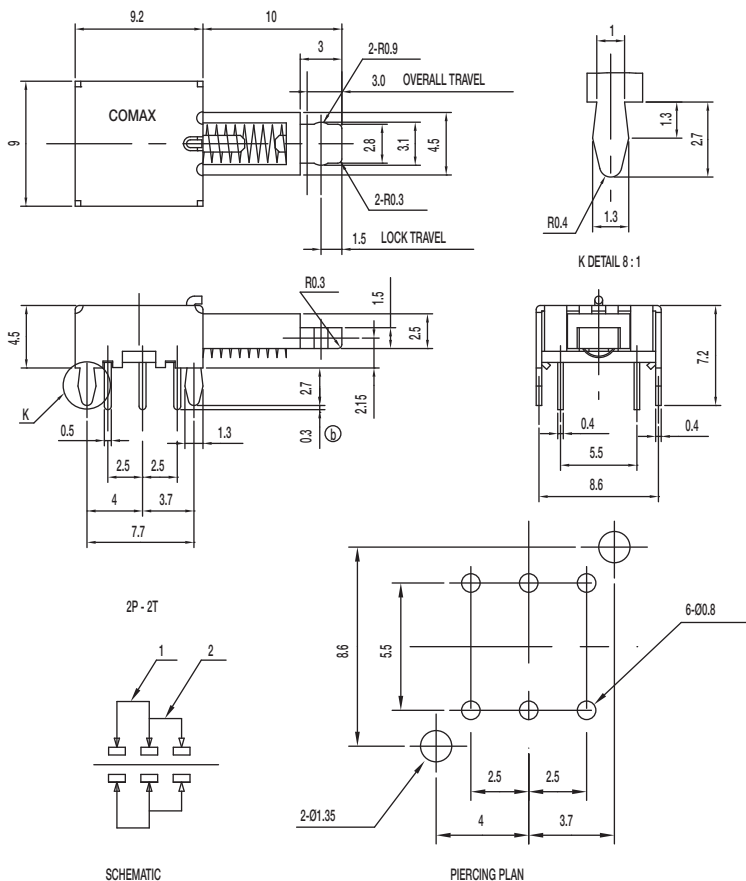

Specifications

- CONTACT RATING: 0.3A @ 30 VDC
- INITIAL CONTACT RESISTANCE: 30 m ohms max.
- INSULATION RESISTANCE: 100 M ohms min.
- DIELECTRIC STRENGTH: 500 V AC (50-60 Hz) between open terminals and between the frame and terminal.
- OPERATING LIFE: 10,000 cycles without load
- OPERATING FORCE: 200 ± 100 gf (1.96 ± 0.98N)
- LOCK TRAVEL: 1.5 ± 0.3 mm
- OVER-TRAVEL: 3 ± 0.3 mm
- OPERATING TEMPERATURE: -20°C to 70°C

Materials

- FRAME: SPCC
- KNOB: POM (UL 94HB)
- CONTACT: Silver plated
- SPRING: SUS
- TERMINAL: Silver plated

PS-22E08-G10 NS DPDT NON-SHORTING

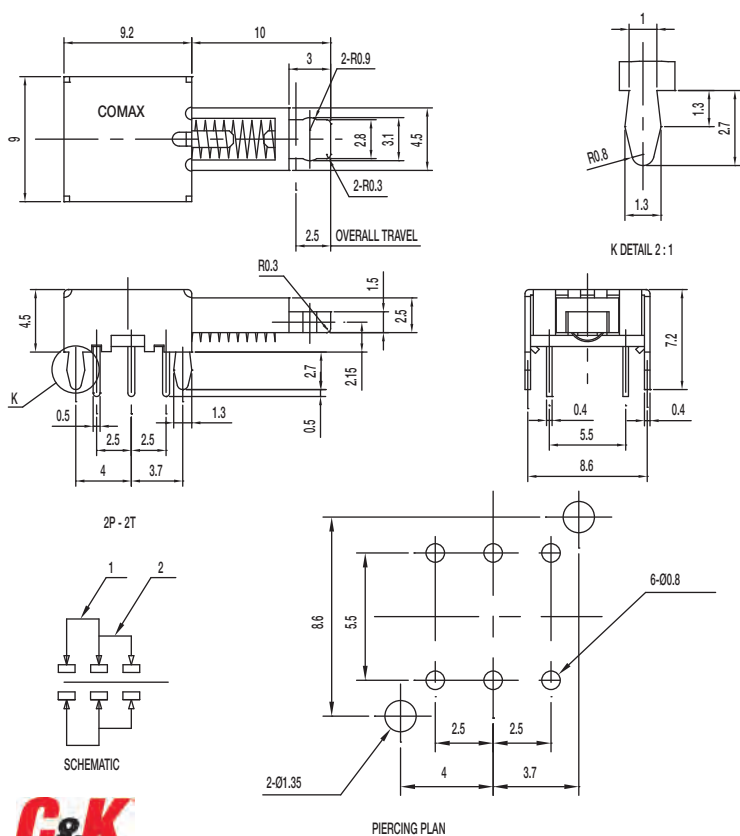

Specifications

- CONTACT RATING: 0.3A @ 30 VDC
- INITIAL CONTACT RESISTANCE: 30 m ohms max.
- INSULATION RESISTANCE: 100 M ohms min.
- DIELECTRIC STRENGTH: 500 V AC (50-60 Hz) between open terminals and between the frame and terminal.
- OPERATING LIFE: 10,000 cycles without load
- OPERATING FORCE: 200 ± 100 gf (1.96 ± 0.98N)
- TOTAL TRAVEL: 2.5 ± 0.3 mm
- OPERATING TEMPERATURE: -20°C to 70°C

Materials

- FRAME: SPCC
- KNOB: POM (UL 94HB)
- CONTACT: Silver plated
- SPRING: SUS
- TERMINAL: Silver plated



Dimensions are shown: mm
Specifications and dimensions subject to change

PS Series Miniature Pushbutton Switches



A

Pushbutton

PS-22E09-G 4.5 NS DPDT NON-SHORTING

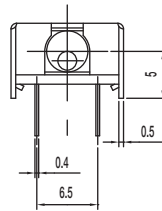
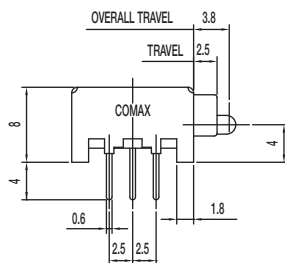
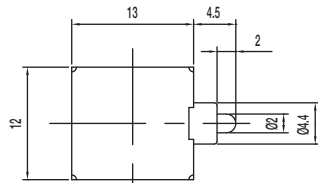

Specifications

CONTACT RATING: 0.3A @ 30 VDC
 INITIAL CONTACT RESISTANCE: 30 m ohms max.
 INSULATION RESISTANCE: 100 M ohms min.
 DIELECTRIC STRENGTH: 500 V AC (50-60 Hz) between open terminals and between the frame and terminal.
 OPERATING LIFE: 10,000 cycles with load
 OPERATING FORCE: 70 ± 20 gf (0.686 ± 0.196N)
 TRAVEL: 2.5 ± 0.3 mm
 TOTAL TRAVEL: 3.8 ± 0.3 mm
 OPERATING TEMPERATURE: -20°C to 70°C

Materials

FRAME: SPCC
 KNOB: POM (UL 94HB)
 CONTACT: Silver plated
 SPRING: SUS
 TERMINAL: Silver plated

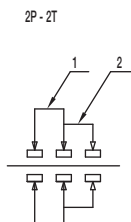

SCHEMATIC

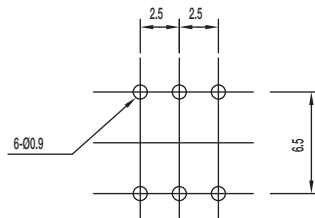

PIERCING PLAN

PS-42D09-NS 4P2T NON-SHORTING

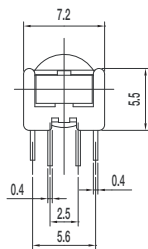
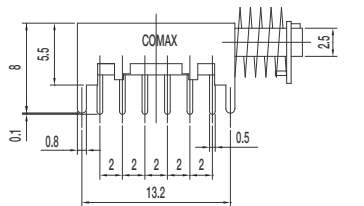
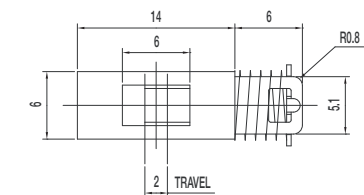

Specifications

CONTACT RATING: 0.3A @ 30 VDC
 INITIAL CONTACT RESISTANCE: 30 m ohms max.
 INSULATION RESISTANCE: 100 M ohms min.
 DIELECTRIC STRENGTH: 500 V AC (50-60 Hz) between open terminals and between the frame and terminal.
 OPERATING LIFE: 10,000 cycles with load
 OPERATING FORCE: 250 ± 100 gf (2.45 ± 0.98N)
 TRAVEL: 2 ± 0.3 mm
 OPERATING TEMPERATURE: -20°C to 70°C

Materials

FRAME: SPCC
 KNOB: POM (UL 94HB)
 CONTACT PLATE: Silver plated
 SPRING: Steel
 TERMINAL: Silver plated

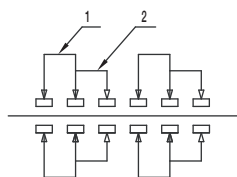

SCHEMATIC

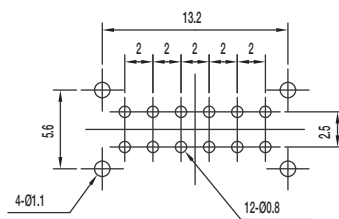

PIERCING PLAN



Dimensions are shown: mm
 Specifications and dimensions subject to change



PS Series Miniature Pushbutton Switches

Pushbutton
A

PS-42D13-NS 4P2T NON-SHORTING

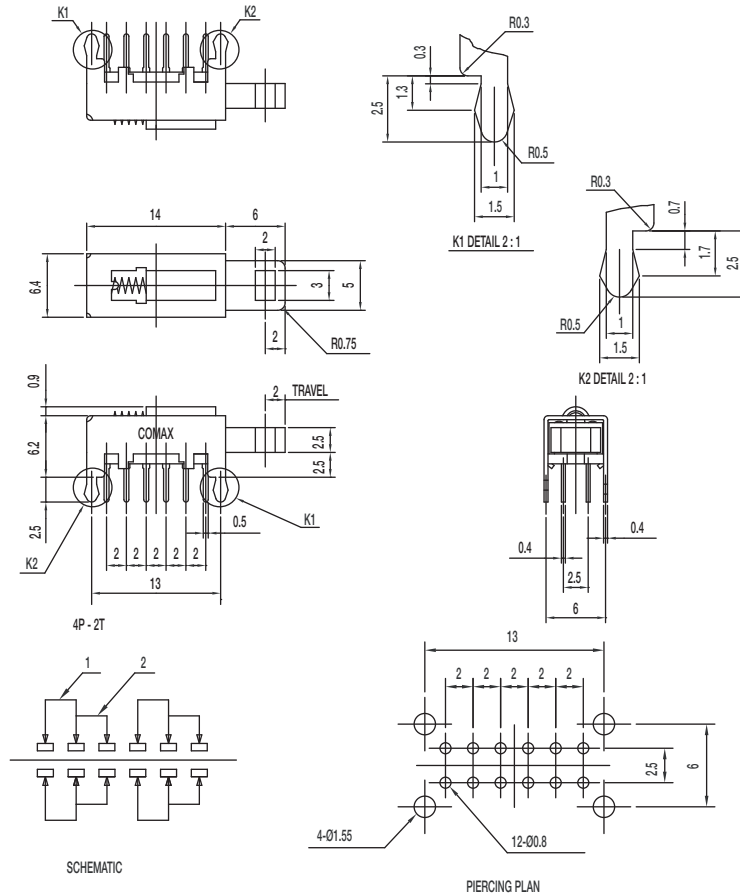

Specifications

CONTACT RATING: 0.3A @ 30 VDC
 INITIAL CONTACT RESISTANCE: 30 m ohms max.
 INSULATION RESISTANCE: 100 M ohms min.
 DIELECTRIC STRENGTH: 500 V AC (50-60 Hz) between open terminals and between the frame and terminal.
 OPERATING LIFE: 10,000 cycles with load
 OPERATING FORCE: 250 ± 100 gf (2.45 ± 0.98N)
 TRAVEL: 2 ± 0.3 mm
 OPERATING TEMPERATURE: -20°C to 70°C

Materials

FRAME: SPCC
 KNOB: POM (UL 94HB)
 CONTACT: Silver plated
 SPRING: Steel
 TERMINAL: Silver plated

PS-42D16-S 4P2T SHORTING

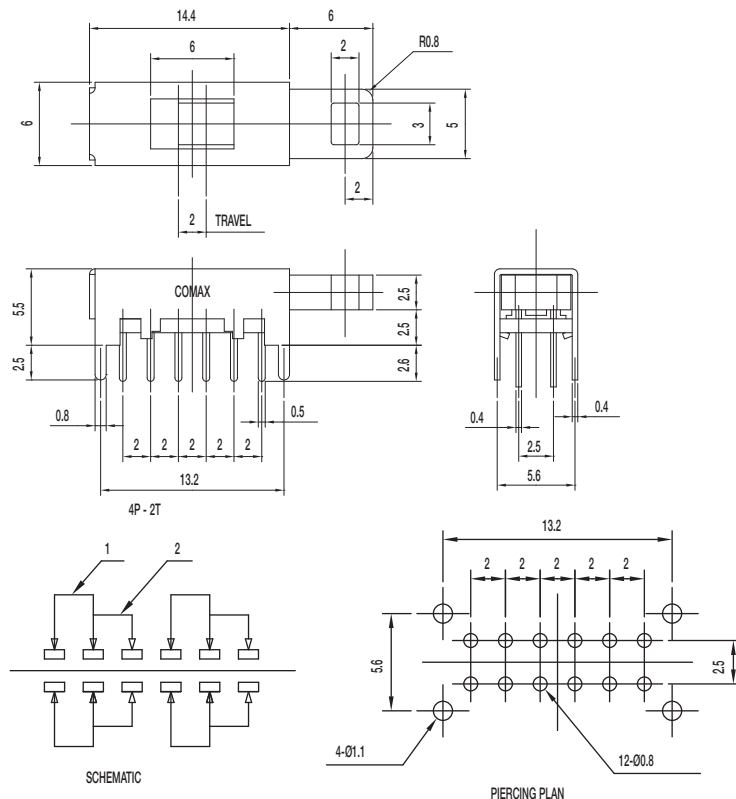

Specifications

CONTACT RATING: 0.3A @ 30 VDC
 INITIAL CONTACT RESISTANCE: 30 m ohms max.
 INSULATION RESISTANCE: 100 M ohms min.
 DIELECTRIC STRENGTH: 500 V AC (50-60 Hz) between open terminals and between the frame and terminal.
 OPERATING LIFE: 10,000 cycles with load
 OPERATING FORCE: 60 ± 30 gf (0.59 ± 0.29N)
 TRAVEL: 2 ± 0.3 mm
 OPERATING TEMPERATURE: -20°C to 70°C

Materials

FRAME: SPCC
 KNOB: POM (UL 94HB)
 CONTACT: Silver plated
 TERMINAL: Silver plated



Dimensions are shown: mm
 Specifications and dimensions subject to change

PS Series Miniature Pushbutton Switches



A

Pushbutton

PS-62D10-S 6P2T SHORTING

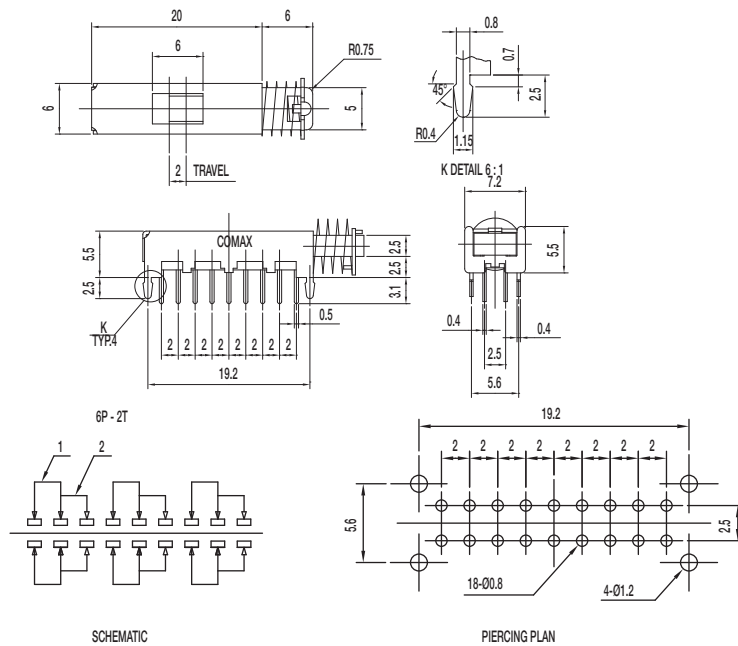

Specifications

CONTACT RATING: 0.3A @ 30 VDC
 INITIAL CONTACT RESISTANCE: 30 m ohms max.
 INSULATION RESISTANCE: 100 M ohms min.
 DIELECTRIC STRENGTH: 500 V AC (50-60 Hz) between open terminals and between the frame and terminal.
 OPERATING LIFE: 10,000 cycles with load
 OPERATING FORCE: 250 ± 100 gf (2.45 ± 0.98N)
 TRAVEL: 2 ± 0.3 mm
 OPERATING TEMPERATURE: -20°C to 70°C

Materials

FRAME: SPCC
 KNOB: POM (UL 94HB)
 CONTACT: Silver plated
 SPRING: Steel
 TERMINAL: Silver plated

PS-62D13-S 6P2T SHORTING

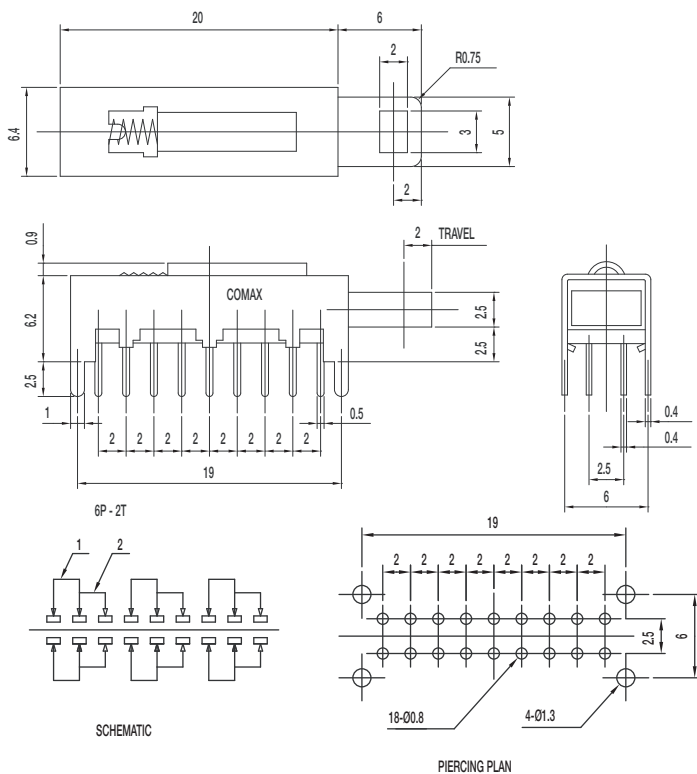

Specifications

CONTACT RATING: 0.3A @ 30 VDC
 INITIAL CONTACT RESISTANCE: 30 m ohms max.
 INSULATION RESISTANCE: 100 M ohms min.
 DIELECTRIC STRENGTH: 500 V AC (50-60 Hz) between open terminals and between the frame and terminal.
 OPERATING LIFE: 10,000 cycles with load
 OPERATING FORCE: 300 ± 100 gf (2.94 ± 0.98N)
 TRAVEL: 2 ± 0.3 mm
 OPERATING TEMPERATURE: -20°C to 70°C

Materials

FRAME: SPCC
 KNOB: POM (UL 94HB)
 CONTACT PLATE: Silver plated
 SPRING: Steel
 TERMINAL: SUS



Dimensions are shown: mm
 Specifications and dimensions subject to change



PS Series Miniature Pushbutton Switches

A

Pushbutton

PS-62D15-S 6P2T SHORTING

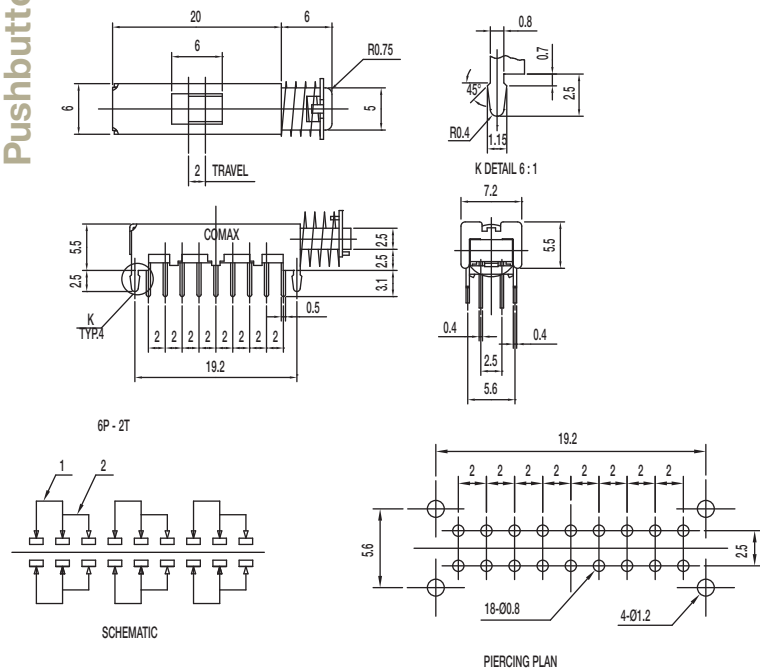

Specifications

CONTACT RATING: 0.3A @ 30 VDC
 INITIAL CONTACT RESISTANCE: 30 m ohms max.
 INSULATION RESISTANCE: 100 M ohms min.
 DIELECTRIC STRENGTH: 500 V AC (50-60 Hz) between open terminals and between the frame and terminal.
 OPERATING LIFE: 10,000 cycles with load
 OPERATING FORCE: 250 ± 100 gf (2.45 ± 0.98N)
 TRAVEL: 2 ± 0.3 mm
 OPERATING TEMPERATURE: -20°C to 70°C

Materials

FRAME: SPCC
 KNOB: POM (UL 94HB)
 CONTACT: Silver plated
 SPRING: Steel
 TERMINAL: Silver plated

PS-22E02-G13 S DPDT SHORTING WITH LOCK

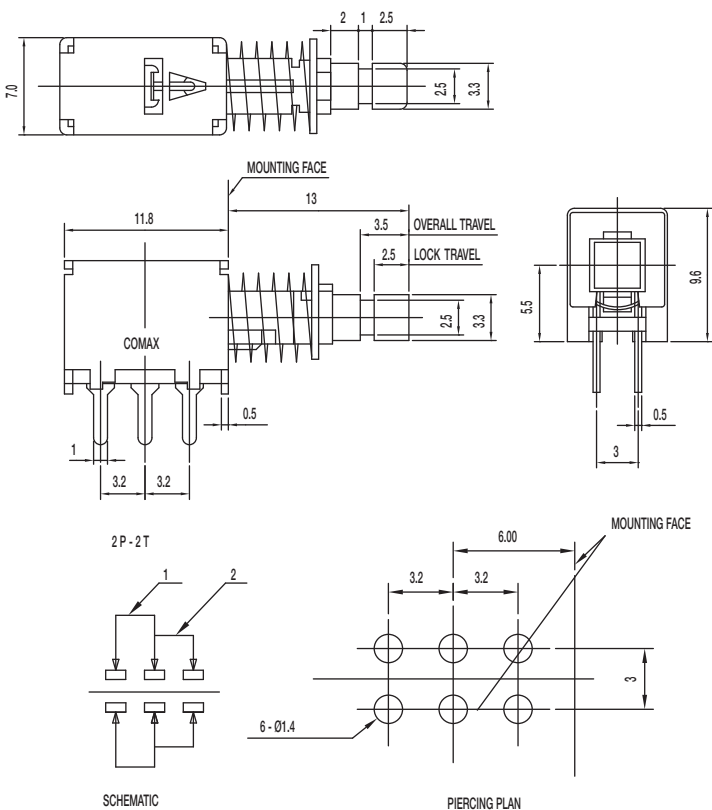

Specifications

CONTACT RATING: 0.3A @ 30 VDC
 INITIAL CONTACT RESISTANCE: 30 m ohms max.
 INSULATION RESISTANCE: 100 M ohms min.
 DIELECTRIC STRENGTH: 500 V AC (50-60 Hz) between open terminals and between the frame and terminal.
 OPERATING LIFE: 10,000 cycles with load
 OPERATING FORCE: 300 ± 100 gf (2.94 ± 0.98N)
 LOCK TRAVEL: 2.5 ± 0.3 mm
 TOTAL TRAVEL: 3.5 ± 0.3 mm
 OPERATING TEMPERATURE: -20°C to 70°C

Materials

FRAME: SPCC
 KNOB: POM (UL 94HB)
 CONTACT: Silver plated
 SPRING: Steel
 TERMINAL: Silver plated



Dimensions are shown: mm
 Specifications and dimensions subject to change

PS Series Miniature Pushbutton Switches



A

Pushbutton

PS-22E04-G13 NS DPDT NON-SHORTING WITH LOCK

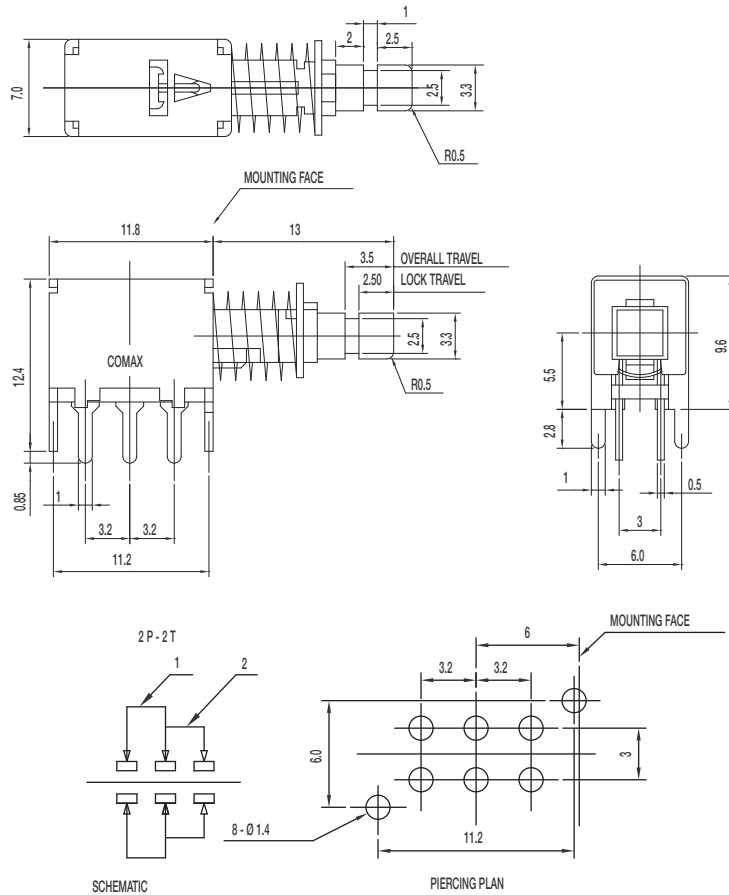

Specifications

CONTACT RATING: 0.3A @ 30 VDC
 INITIAL CONTACT RESISTANCE: 30 m ohms max.
 INSULATION RESISTANCE: 100 M ohms min.
 DIELECTRIC STRENGTH: 500 V AC (50-60 Hz) between open terminals and between the frame and terminal.
 OPERATING LIFE: 10,000 cycles with load
 OPERATING FORCE: 300 ± 100 gf (2.94 ± 0.98N)
 LOCK TRAVEL: 2.5 ± 0.3 mm
 TOTAL TRAVEL: 3.5 ± 0.3 mm
 OPERATING TEMPERATURE: -20°C to 70°C

Materials

FRAME: SPCC
 KNOB: POM (UL 94HB)
 CONTACT: Silver plated
 SPRING: Steel
 TERMINAL: Silver plated

PS-22E44-G13 NS DPDT NON-SHORTING WITH LOCK

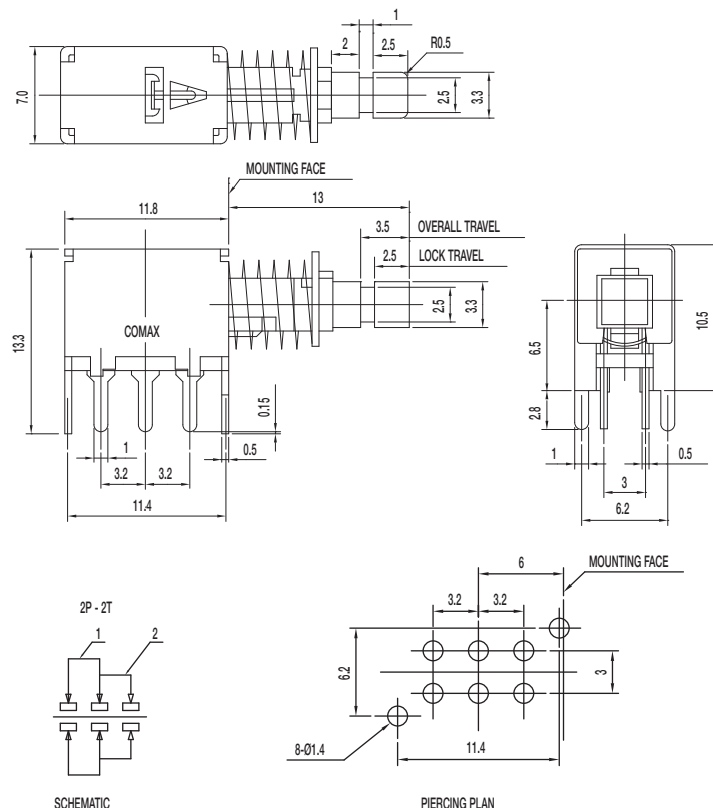

Specifications

CONTACT RATING: 0.3A @ 30 VDC
 INITIAL CONTACT RESISTANCE: 30 m ohms max.
 INSULATION RESISTANCE: 100 M ohms min.
 DIELECTRIC STRENGTH: 500 V AC (50-60 Hz) between open terminals and between the frame and terminal.
 OPERATING LIFE: 10,000 cycles with load
 OPERATING FORCE: 300 ± 100 gf (2.94 ± 0.98N)
 LOCK TRAVEL: 2.5 ± 0.3 mm
 TOTAL TRAVEL: 3.5 ± 0.3 mm
 OPERATING TEMPERATURE: -20°C to 70°C

Materials

FRAME: SPCC
 KNOB: POM (UL 94HB)
 CONTACT: Silver plated
 SPRING: Steel
 TERMINAL: Silver plated



Dimensions are shown: mm
 Specifications and dimensions subject to change



PS Series Miniature Pushbutton Switches

Pushbutton
A

PS-22E75-G13 NS DPDT NON-SHORTING WITH LOCK

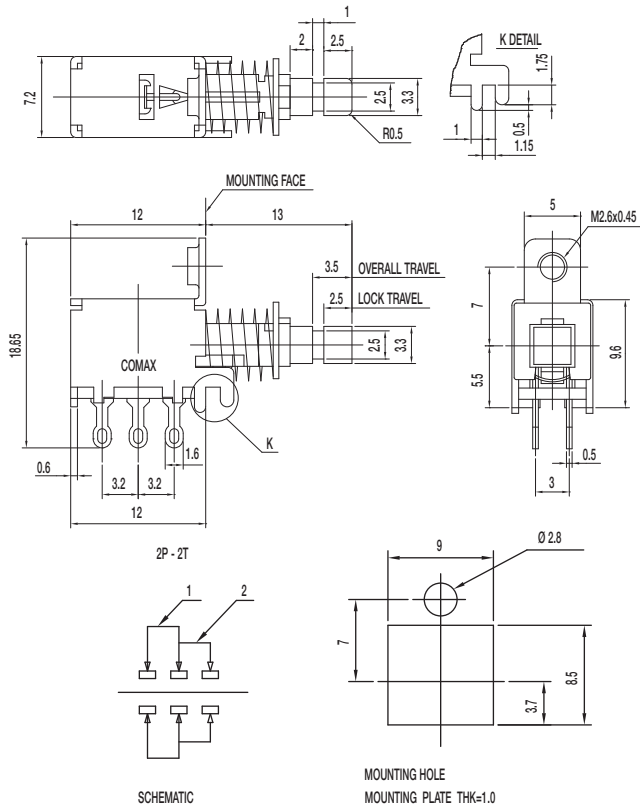

Specifications

CONTACT RATING: 0.3A @ 30 VDC
 INITIAL CONTACT RESISTANCE: 30 m ohms max.
 INSULATION RESISTANCE: 100 M ohms min.
 DIELECTRIC STRENGTH: 500 V AC (50-60 Hz) between open terminals and between the frame and terminal.
 OPERATING LIFE: 10,000 cycles with load
 OPERATING FORCE: 300 ± 100 gf (2.94 ± 0.98N)
 LOCK TRAVEL: 2.5 ± 0.3 mm
 TOTAL TRAVEL: 3.5 ± 0.3 mm
 OPERATING TEMPERATURE: -20°C to 70°C

Materials

FRAME: SPCC
 KNOB: POM (UL 94HB)
 CONTACT: Silver plated
 SPRING: Steel
 TERMINAL: Silver plated

PS-22E95-G13 NS DPDT NON-SHORTING WITH LOCK

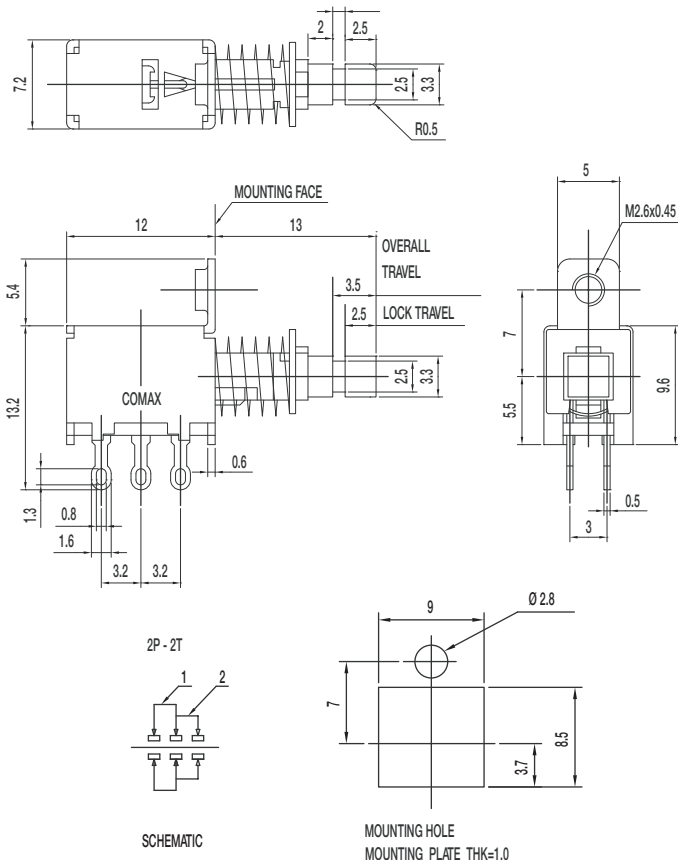

Specifications

CONTACT RATING: 0.3A @ 30 VDC
 INITIAL CONTACT RESISTANCE: 30 m ohms max.
 INSULATION RESISTANCE: 100 M ohms min.
 DIELECTRIC STRENGTH: 500 V AC (50-60 Hz) between open terminals and between the frame and terminal.
 OPERATING LIFE: 10,000 cycles with load
 OPERATING FORCE: 300 ± 100 gf (2.94 ± 0.98N)
 LOCK TRAVEL: 2.5 ± 0.3 mm
 TOTAL TRAVEL: 3.5 ± 0.3 mm
 OPERATING TEMPERATURE: -20°C to 70°C

Materials

FRAME: SPCC
 KNOB: POM (UL 94HB)
 CONTACT: Silver plated
 SPRING: Steel
 TERMINAL: Silver plated



Dimensions are shown: mm
 Specifications and dimensions subject to change

PS Series Miniature Pushbutton Switches



A

Pushbutton

PS-22F02-G13 S DPDT SHORTING

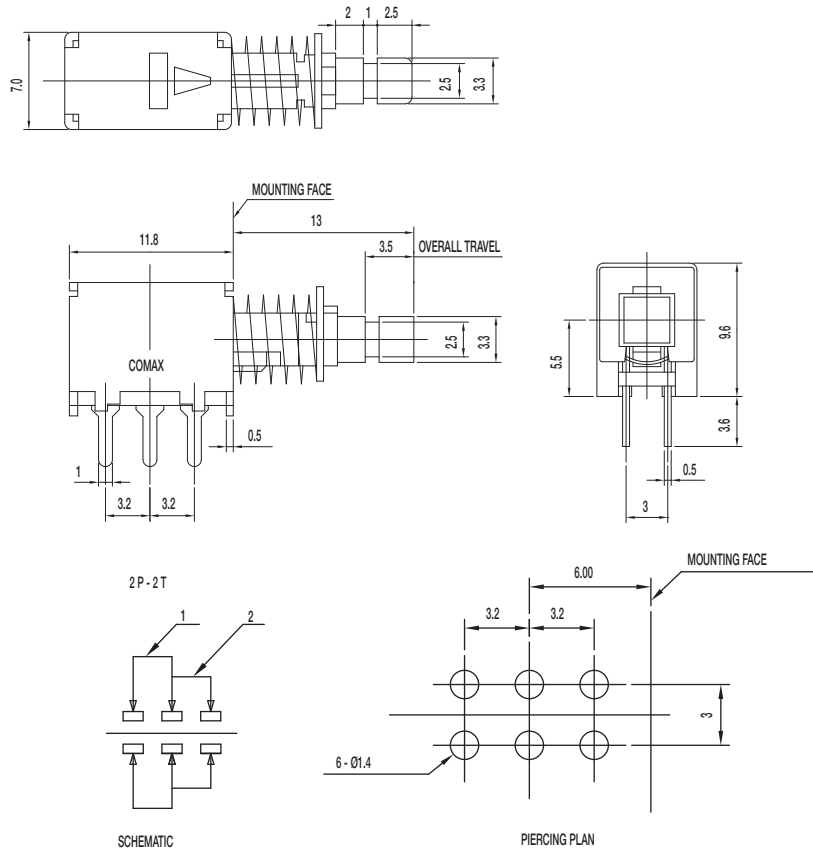

Specifications

CONTACT RATING: 0.3A @ 30 VDC
 INITIAL CONTACT RESISTANCE: 30 m ohms max.
 INSULATION RESISTANCE: 100 M ohms min.
 DIELECTRIC STRENGTH: 500 V AC (50-60 Hz)
 between open terminals and between the frame and terminal.
 OPERATING LIFE: 10,000 cycles with load
 OPERATING FORCE: 300 ± 100 gf (2.94 ± 0.98N)
 TOTAL TRAVEL: 3.5 ± 0.3 mm
 OPERATING TEMPERATURE: -20°C to 70°C

Materials

FRAME: SPCC
 KNOB: POM (UL 94HB)
 CONTACT: Silver plated
 SPRING: Steel
 TERMINAL: Silver plated

PS-22F04-G13 NS DPDT NON_SHORTING

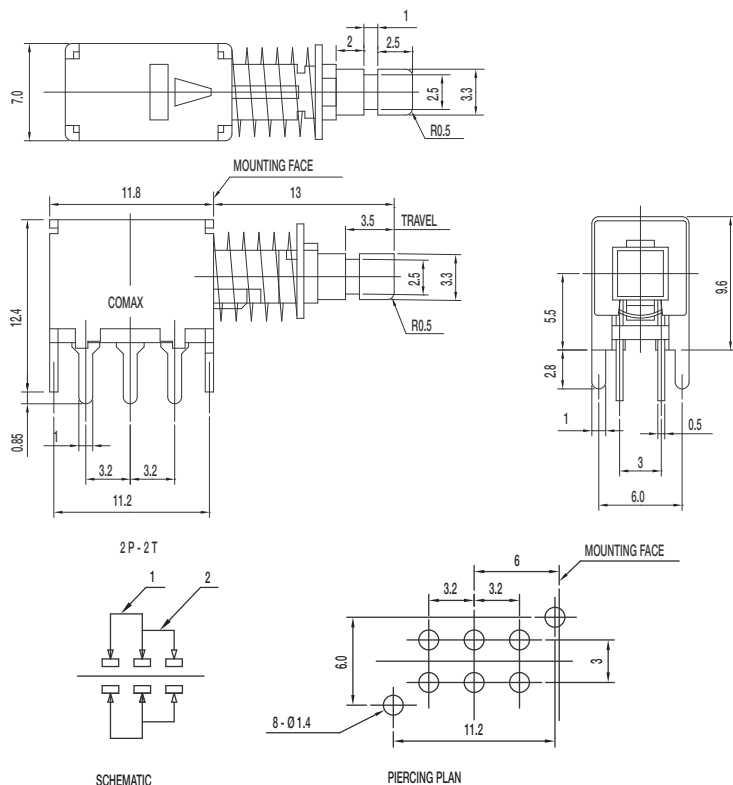

Specifications

CONTACT RATING: 0.3A @ 30 VDC
 INITIAL CONTACT RESISTANCE: 30 m ohms max.
 INSULATION RESISTANCE: 100 M ohms min.
 DIELECTRIC STRENGTH: 500 V AC (50-60 Hz) between open terminals and between the frame and terminal.
 OPERATING LIFE: 10,000 cycles with load
 OPERATING FORCE: 300 ± 100 gf (2.94 ± 0.98N)
 TOTAL TRAVEL: 3.5 ± 0.3 mm
 OPERATING TEMPERATURE: -20°C to 70°C

Materials

FRAME: SPCC
 KNOB: POM (UL 94HB)
 CONTACT: Silver plated
 SPRING: Steel
 TERMINAL: Silver plated



Dimensions are shown: mm
 Specifications and dimensions subject to change



PS Series Miniature Pushbutton Switches

Pushbutton
A

PS-22F24-G13 NS DPDT NON_SHORTING

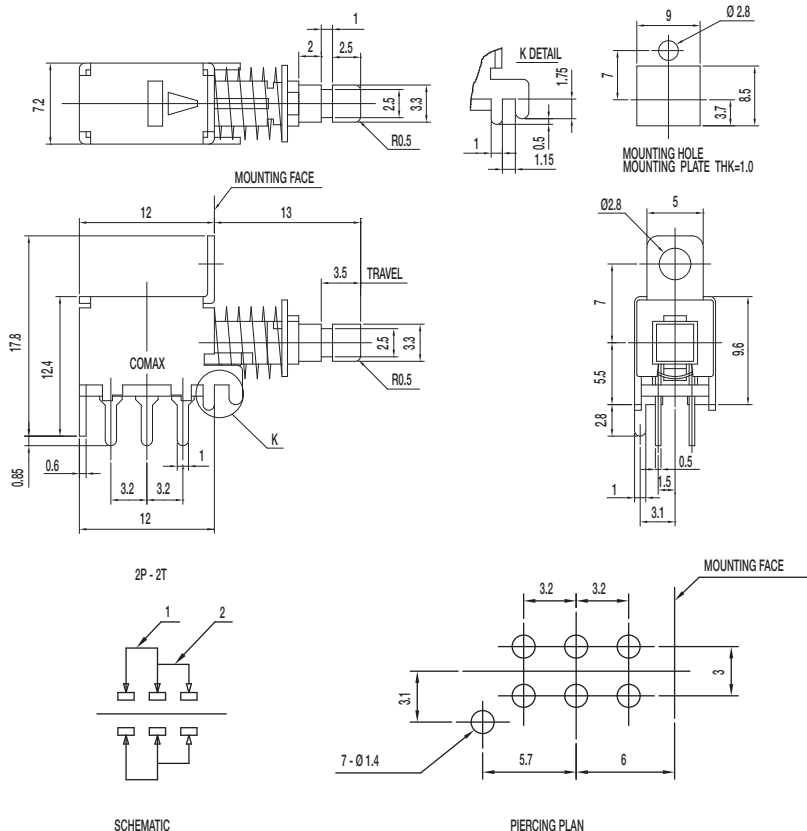

Specifications

CONTACT RATING: 0.3A @ 30 VDC
 INITIAL CONTACT RESISTANCE: 30 m ohms max.
 INSULATION RESISTANCE: 100 M ohms min.
 DIELECTRIC STRENGTH: 500 V AC (50-60 Hz) between open terminals and between the frame and terminal.
 OPERATING LIFE: 10,000 cycles with load
 OPERATING FORCE: 300 ± 100 gf (2.94 ± 0.98N)
 TOTAL TRAVEL: 3.5 ± 0.3 mm
 OPERATING TEMPERATURE: -20°C to 70°C

Materials

FRAME: SPCC
 KNOB: POM (UL 94HB)
 CONTACT: Silver plated
 SPRING: Steel
 TERMINAL: Silver plated

PS-22F44-G13 NS DPDT NON_SHORTING

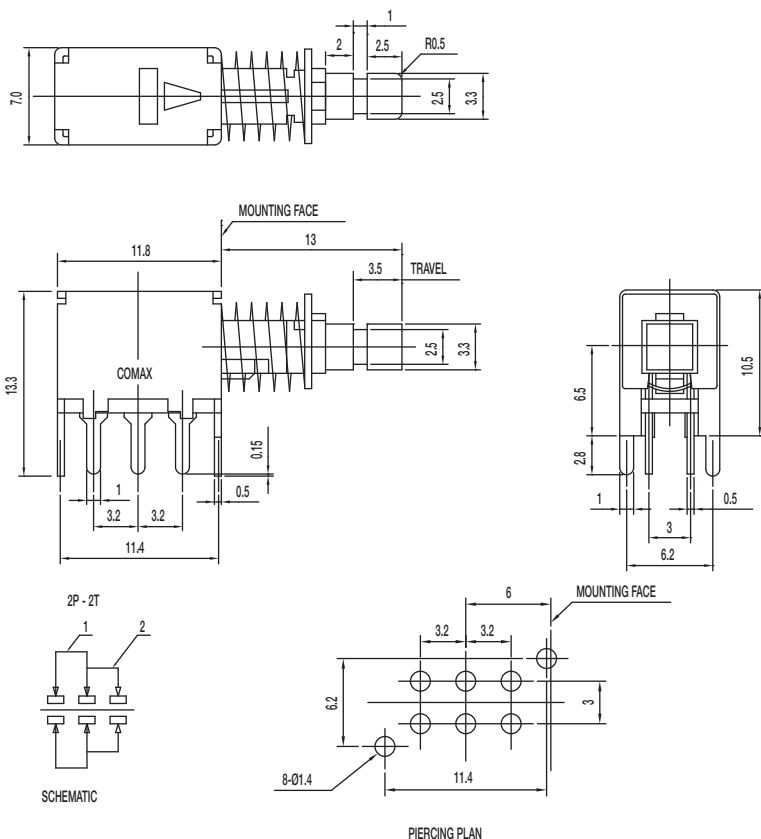

Specifications

CONTACT RATING: 0.3A @ 30 VDC
 INITIAL CONTACT RESISTANCE: 30 m ohms max.
 INSULATION RESISTANCE: 100 M ohms min.
 DIELECTRIC STRENGTH: 500 V AC (50-60 Hz) between open terminals and between the frame and terminal.
 OPERATING LIFE: 10,000 cycles with load
 OPERATING FORCE: 300 ± 100 gf (2.94 ± 0.98N)
 TOTAL TRAVEL: 3.5 ± 0.3 mm
 OPERATING TEMPERATURE: -20°C to 70°C

Materials

FRAME: SPCC
 KNOB: POM (UL 94HB)
 CONTACT: Silver plated
 SPRING: Steel
 TERMINAL: Silver plated



Dimensions are shown: mm
 Specifications and dimensions subject to change

Tactile Switches

Product Selection Guide





Tactile Switches

| | | | | | | | |
|--------------------------------------|---|---|---|---|---|---|---|
| Surface Mount |  |  |  |  |  |  |  |
| Series | KXT2 | KXT3 | KMT2 | KMT0 | KMR 2-8 | KMS | PTS525 |
| Size on PCB L x W (mm) | 3,9 x 3 | 3 x 2 | 3 x 2,6 | 3 x 2,6 | 4,2 x 2,8 | 4,2 x 3,55 | 5,2 x 5,2 |
| Total Height (mm) | 1,05 | 0,6 | 0,65 | 0,65 | 1,9 2,5 | 1,42 | 0,8 and 1,5 |
| Travel (mm) | 0,1 | 0,13 | 0,15 | 0,15 | 0,2 to 0,35 | 0,25 to 0,3 | 0,3 |
| Actuation Force (N) | 100 gf 200 gf | 100 gf 160gf 240 gf 330 gf | 1,0 1,6 | 1,0; 1,6 2,3; 3,4 | 1,2; 2,0 3,0; 4,0 | 2,0 3,0 | 1,6 2,6 |
| Contact Type | Silver | Silver | Silver | Silver | Silver / Gold | Silver / Gold | Silver |
| Max. Voltage (V) | 12 | 15 | 32 | 32 | 32 | 32 | 32 |
| Max. Switching Power (VA) | 0,5 | 0,5 | 0,5 | 0,5 | 1 / 0,2 | 1 / 0,2 | 1 |
| Life Cycles | 100,000 | 300,000 500,000 | 150,000 | 300,000/600,000 1,000,000 | 100,000 300,000 | 100,000 | 100,000 |
| IP Rating | IP64 | IP64 | IP54 | IP68 | IP40 | IP40 | IP40 |
| Page Number | B-5 | B-7 | B-9 | B-11 | B-13 | B-23 | B-25 |
| Surface Mount |  |  |  |  |  |  |  |
| Series | PTS530 | PTS540 | PTS810 | PTS820 | PTS830 | PTS840 | KSR |
| Size on PCB L x W (mm) | 4,5 x 4,5 | 3,7 x 3,7 | 4,2 x 3,2 | 3,9 x 2,9 | 3,5 x 2,6 | 3,5 x 3,55 | 7,15 x 3,8 7,3 x 3,8 |
| Total Height (mm) | 0,55 and 0,65 | 0,55 / 0,65 | 2,5 | 1,5/2,0/2,5 | 1,4 | 1,35 | 2,5 |
| Travel (mm) | 0,2 | 0,15 | 0,15/0,2 | 0,2 | 0,15 | 0,2 | 0,3 to 0,5 |
| Actuation Force (N) | 1,0; 1,6; 2,0; 2,6; 4,0; 6,0 | 160 gf 230 gf | 1,6; 2,6; 4,0; 6,0 | 1,6 2,5 | 160 gf 450 gf | 1,6 2,2 | 1,2; 2,0; 3,0; 4,5 |
| Contact Type | Silver | Silver | Silver | Silver | Silver | Silver | Silver / Gold |
| Max. Voltage (V) | 12 | 12 | 16 | 12 | 12 | 12 | 32 |
| Max. Switching Power (VA) | - | - | - | - | - | - | 1 / 0,2 |
| Life Cycles | 150,000 to 1,000,000 | 300,000 500,000 | 50,000 to 150,000 | 100,000 200,000 | 200,000 500,000 | 100,000 | 100,000 200,000 |
| IP Rating | - | IP40 | IP40 | IP40 | IP40 | IP40 | IP50 |
| Page Number | B-29 | B-31 | B-33 | B-35 | B-38 | B-42 | B-45 |

* Other options available by request

Dimensions are shown: mm
Specifications and dimensions subject to change

Tactile Switches Product Selection Guide

| Surface Mount Thru-Hole Options |  |  |  | | |  |  |
|---------------------------------------|---|---|--|---------------|--|---|---|
| Series | KSS | KSC4V2 | KSC 1 - 10 | | | KSE | KT |
| Footprint | 5,5 x 4,4 | 2 holes ø 1,1 2 pads 1,5 x 0,8 | J 6,8 x 6,2 | G 10 x 6,2 | | 6,8 x 6,2 | SA 7,5x5 SA2 7,5x7 |
| Total Height (mm) | 1,7 | 5,0* | | | | 3,1 / 4,3 | 6,6 7,11 with tab |
| Travel (mm) | 0,3 | 0,7* | 0,20 to 0,75 * | | | 0,3 | 0,3 to 0,5 |
| Actuation Force (N) | 2 2,5 4 | 3.5* | 1,1 to 5,5 * | | | 1.5 2.25 | 3 |
| Contact Type | Silver / Gold | Silver / Gold | Silver / Gold | | | Silver | Silver / Gold |
| Max. Voltage (V) | 32 | 32 | 32 | | | 32 | 50 |
| Max. Switching Power (VA) | 1 / 0,2 | 1 / 0,2 | 1 / 0.2 | | | 1 | 1 / 0.2 |
| Life Cycles | 100,000 | 300,000 | 100,000 to 1,000,000 | | | 300,000 | 100,000 |
| IP Rating | IP40 | IP67 | IP67 | | | IP67 | |
| Page Number | B-49 | B-63 | B-51 | | | B-65 | B-68 |

| Surface Mount Thru-Hole Options |  |  |  |  |  |  |  |
|---------------------------------------|---|---|---|--|---|---|---|
| Series | K5AT | K8 | K5V | KSF/KSI | KSA | KSA-V | KSA MKII |
| Footprint | G 8,4 x 10,8 | G 8,4 x 10,8 | 8 x 9 x 17 / 9 x 13 | 7,62 x 5,08 | 7,62 x 5,08 | 7,62 x 2,54 | 7,62 x 5,08 |
| Total Height (mm) | 6,1 | 6 | 9 / 13 | 2,6 | 4,7 button option | 8 | 4,7 |
| Travel (mm) | 0,5 | 0,45 | 1,2 | 0,3 to 0,5 | 0,3 to 0,5 | 0,3 to 0,5 | 0,3 to 0,5 |
| Actuation Force (N) | 4.0 | 4.0 | 4.0 | 1.3 3.0 1.6 5.0 | 1.3 3.0 5.0 | 1.3 3.0 5.0 | 1.3 3.0 5.0 |
| Contact Type | Gold | Silver | Gold | Silver / Gold | Silver / Gold | Silver / Gold | Silver / Gold |
| Max. Voltage (V) | 32 | 32 | 32 | 32 | 32 | 32 | 32 |
| Max. Switching Power (VA) | 1 | 1 | 1 | 1 / 0.2 | 1 / 0.2 | 1 / 0.2 | 1 / 0.2 |
| Life Cycles | 100,000 | 300,000 | 25,000 | 100,000 | 100,000 | 100,000 | 100,000 1,000,000 |
| IP Rating | IP40 | IP40 | IP40 | IP60 | IP60 | IP60 | IP67 |
| Page Number | B-73 | B-75 | B-78 | B-82 | B-84 | B-84 | B-89 |





* Other options available by request

Tactile Switches

Product Selection Guide

Tactile Switches

B

| Surface Mount Thru-Hole Options |  |  |  |  |  |
|---------------------------------|---|---|---|---|---|
| Series | KSJ | KSJ-V | KSJ | KSJ-V | PTS635 |
| Footprint | 7,62 x 5,08 | 7,62 x 2,54 | 7,62 x 5,08 | 7,62 x 2,54 | 6 x 3,5 |
| Total Height (mm) | 9,9 | 8 | 6,65 | 8 | 2,5 4,3 5,0 |
| Travel (mm) | 0,3 to 0,5 | 0,3 to 0,5 | 0,55 to 0,7 | 0,55 to 0,7 | 0,25 |
| Actuation Force (N) | 1,3 3,0 | 1,3 3,0 | 2,0 3,0 | 2,0 3,0 | 1,3 2,0 2,6 |
| Contact Type | Silver / Gold | Silver / Gold | Silver / Gold | Silver / Gold | Silver |
| Max. Voltage (V) | 32 | 32 | 32 | 32 | 12 |
| Life Cycles | 100,000 | 100,000 | 100,000 30,000 | 100,000 30,000 | 20,000 |
| IP Rating | IP60 | IP60 | IP60 | IP60 | IP40 |
| Page Number | B-84 | B-84 | B-91 | B-91 | B-93 |

| Surface Mount Thru-Hole Options |  |  |  |  |  | |
|---------------------------------|---|---|---|---|---|--|
| Series | PTS641 | PTS645 | PTS645-V | PTS125 | ITS | |
| Footprint | 6,3 x 6,4 | 6 x 6 | 7,0 x 2,5 | 12 x 12 | variety of sizes available | |
| Total Height (mm) | 2,5 3,1 3,4 | 4,3; 5,0; 7,0; 9,5; | 7,1 | 4,3 7,3 Sq. 8,5 12,0 | | |
| Travel (mm) | 0,20 / 0,30 | 0,25 | 0,25 | 0,30 | 0,25 | |
| Actuation Force (N) | 160 gf 250 gf 320 gf | 1,3; 1,6 2,0; 2,6 | 1,3; 1,6 2,0; 2,6 | 1,6 2,6 | 160 gf | |
| Contact Type | Silver | Silver | Silver | Silver | Silver | |
| Max. Voltage (V) | 12 | 12 | 12 | 12 | 12 | |
| Life Cycles | 100,000 | 100,000 | 100,000 | 200,000 | 50,000 | |
| IP Rating | IP40 | IP40 | IP40 | IP40 | IP40 | |
| Page Number | B-96 | B-98 | B-103 | B-105 | B-109 | |

KXT2 Series Double Action Ultra Low Profile Top Actuated

Features

- 3.9 x 3.0 mm footprint
- 1.05 mm thickness
- Dual action

Typical Applications

- Wearable electronics
- Mobile Phones
- Portable Electronics

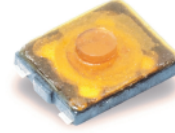

B

Tactile Switches

Specification

FUNCTION: momentary action
 CONTACT ARRANGEMENT: Dual action = SPDT, N.O.
 TERMINALS: G type for SMT
 TRAVEL: 0.1 mm ± 0.05 mm
 TRAVEL: 0.2 mm + 0.1 / - 0.05 mm

Mechanical

| | Operating force gf | | Operating Life |
|-------------|--------------------|----------|----------------|
| KXT 211 LHS | Push force 1 | 100 ± 40 | 100,000 |
| | Push force 2 | 200 ± 50 | |

Electrical

MAXIMUM VOLTAGE: 12 VDC
 MAXIMUM CURRENT DC: 50 mA
 DIELECTRIC STRENGTH: 250 V (50 Hz, 1 min.)
 CONTACT RESISTANCE: ≤ 500 mΩ
 INSULATION RESISTANCE: 100 MΩ
 BOUNCE TIME: ≤ 10 ms

Environmental

OPERATING TEMPERATURE: -40°C to 85°C
 STORAGE TEMPERATURE: -40°C to 85°C

Process

SOLDERING: This component is suited to the following methods:
 Infrared Reflow Soldering in accordance with IEC61760-1

Packaging

In reels of 6,000 pieces
 Dimensions of reels according to EIA RS481 or IEC 2863
 External diameter 178 mm ± 2mm

NOTE: Specifications listed above are for switches with standard options.
 For information on specific and custom switches, consult Customer Service Center.

Part Number Description

For any part number different from those listed above, please consult your local representative.

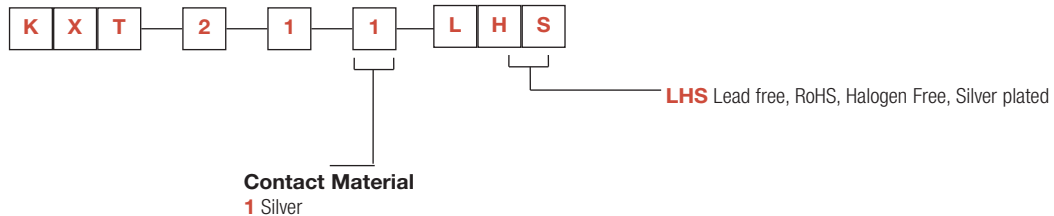

KXT2 Series Double Action Ultra Low Profile Top Actuated

B

Tactile Switches

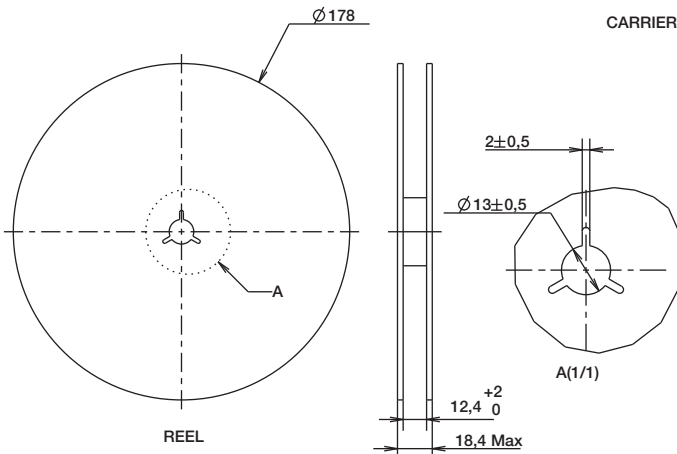
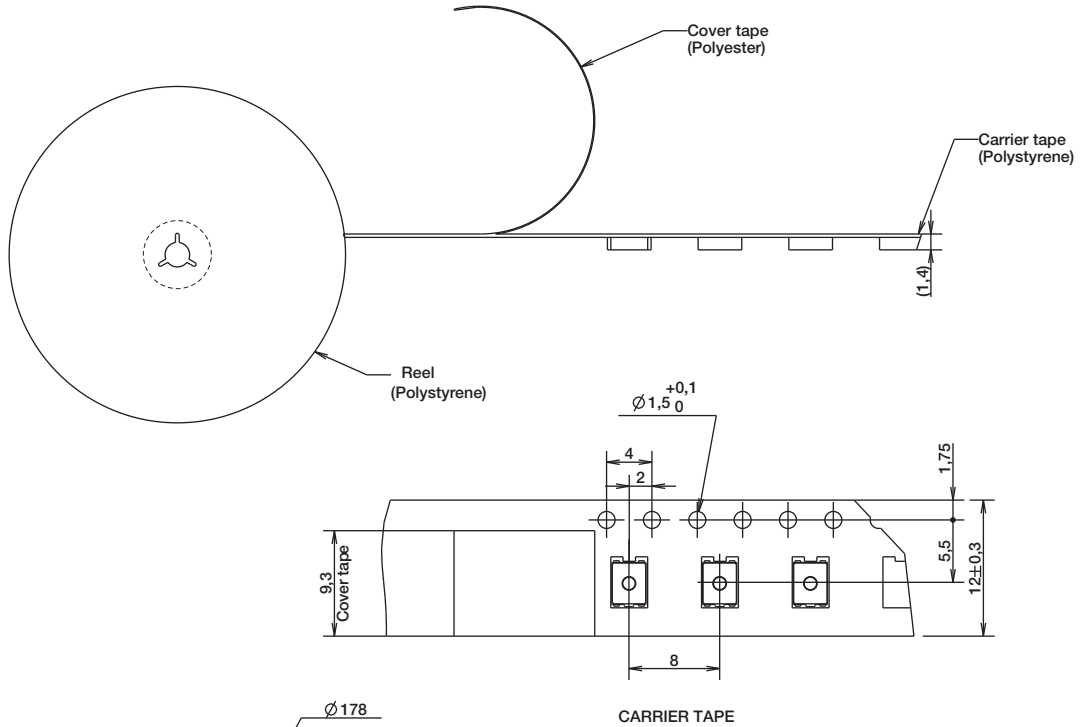
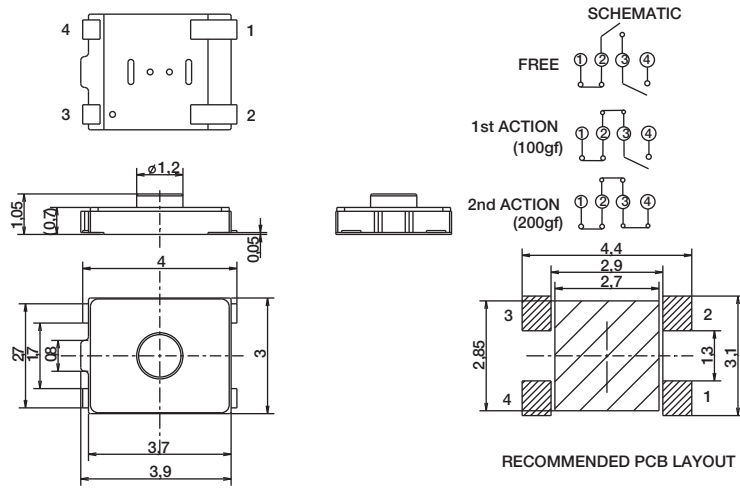

Dimensions are shown: mm
Specifications and dimensions subject to change

KXT3 Series Ultra Low Profile Top Actuated

Features

- 3.0 x 2.0 mm footprint
- 0.6 mm thickness
- High number of cycle

Typical Applications

- Wearable electronics
- In-Ear headphones, Earbuds
- Mobile Phones
- Portable Electronics
- Hearing Aids

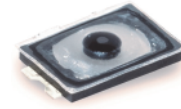

B

Tactile Switches

Specification

FUNCTION: momentary action
 CONTACT ARRANGEMENT: 1 make contact = SPST, N.O.
 TERMINALS: G type for SMT
 TRAVEL: 0.13 mm ± 0.05 mm

Mechanical

| | Operating force gf | Operating Life | Casing Color |
|-------------|-----------------------|-------------------|-----------------|
| KXT 311 LHS | 100 ± 50 | 300,000 | Black |
| KXT 321 LHS | 160 ± 50 | 500,000 | Black |
| KXT 331 LHS | 240 ± 70 | 500,000 | Black |
| KXT 341 LHS | 330 ± 70 | 300,000 | Black |

Electrical

MAXIMUM VOLTAGE: 15 VDC
 MAXIMUM CURRENT DC: 20 mA
 DIELECTRIC STRENGTH: (50/60 Hz, 1 min) 250 Vrms
 CONTACT RESISTANCE: ≤ 500 mΩ
 INSULATION RESISTANCE: ≥ 50 MΩ
 BOUNCE TIME: ≤ 10 ms

Environmental

OPERATING TEMPERATURE: -40°C to 85°C
 STORAGE TEMPERATURE: -40°C to 85°C

Process

SOLDERING: This component is suited to the following methods:
 Infrared Reflow Soldering in accordance with IEC61760-1

Packaging

In reels of 8,500 pieces
 Dimensions of reels according to EIA 481B
 External diameter 330 mm

NOTE: Specifications listed above are for switches with standard options.
 For information on specific and custom switches, consult Customer Service Center.

Part Number Description

For any part number different from those listed above, please consult your local representative.

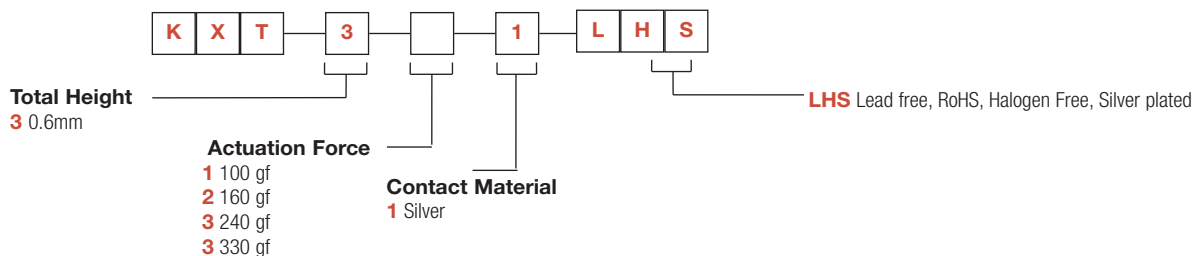

KXT3 Series Ultra Low Profile Top Actuated

Tactile Switches

B

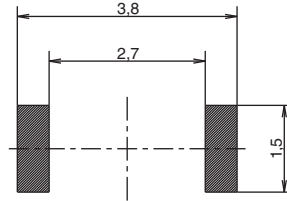
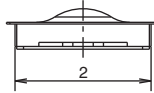
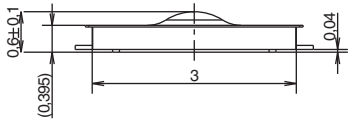
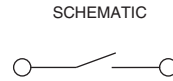
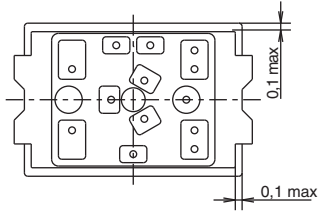

RECOMMENDED PCB LAYOUT

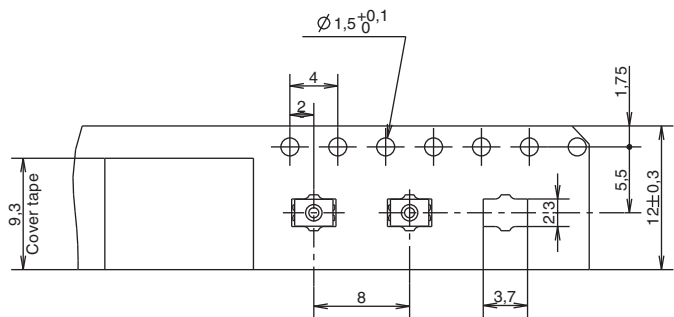
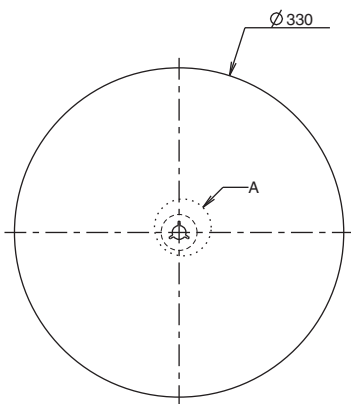
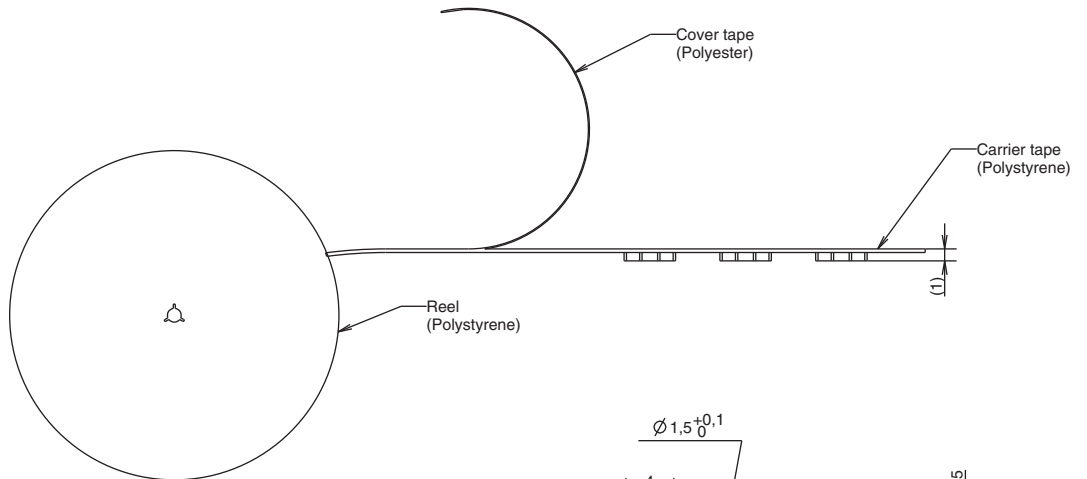
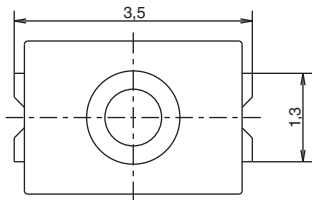

CARRIER TAPE NOTE:

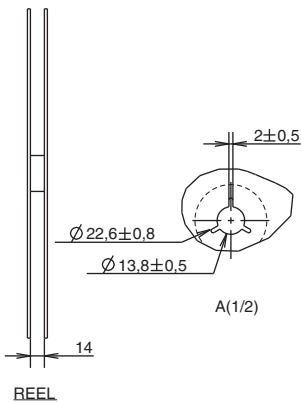

4 jan 17

KMT2 Series Nano-Miniature SMT Top Actuated

Features

- **Smallest footprint**
- **High number of cycles within the smallest packaging**
- **Smallest thickness with integrated actuator**
- **Ground pin option**
- **Halogen free**

Typical Applications

- **Mobile Phones**
- **Hearing Aids**
- **MP3 accessories**
- **Bluetooth Headset**



B

Tactile Switches

Specification

FUNCTION: momentary action
CONTACT ARRANGEMENT: 1 make contact = SPST, N.O.
TERMINALS: Gullwing type for SMT

Mechanical

| Type G and NG | Operating force Newtons (grams) | Operating Life | Tactile Feeling | Travel mm |
|----------------|------------------------------------|-------------------|--------------------|------------|
| KMT 211 HF LFS | 1.0 (100) ± 0.25 | 150,000 | ≥ 10% | 0.15 ± 0.1 |
| KMT 221 HF LFS | 1.6 (160) ± 0.40 | 150,000 | ≥ 30% | 0.15 ± 0.1 |

Electrical

| | |
|------------------------|------------------|
| | Silver |
| MAXIMUM POWER: | 0.5 VA |
| MAXIMUM VOLTAGE: | 32 VDC |
| MINIMUM VOLTAGE: | 20 mV |
| MAXIMUM CURRENT DC: | 50 mA |
| MINIMUM CURRENT DC: | 1 mA |
| DIELECTRIC STRENGTH: | ≥ 250 Vrms (1mn) |
| CONTACT RESISTANCE: | ≤ 150 mΩ |
| INSULATION RESISTANCE: | ≥ 50 MΩ |
| BOUNCE TIME: | ≤ 6 ms |

Environmental

| | |
|------------------------|-----------------------------------|
| | Silver |
| OPERATING TEMPERATURE: | -40°C to 85°C |
| STORAGE TEMPERATURE: | -55°C (10 days) +85°C (4 days) |

Process

SOLDERING: This component is suited to the following methods:
– Infrared Reflow Soldering in accordance with IEC61760-1

Packaging

In reels of 4,000 pieces.
Dimensions of reels according to EIA 481B
External diameter 180 mm

NOTE: Specifications listed above are for switches with standard options.
For information on specific and custom switches, consult Customer Service Center.

Part Number Description

For any part number different from those listed above, please consult your local representative.

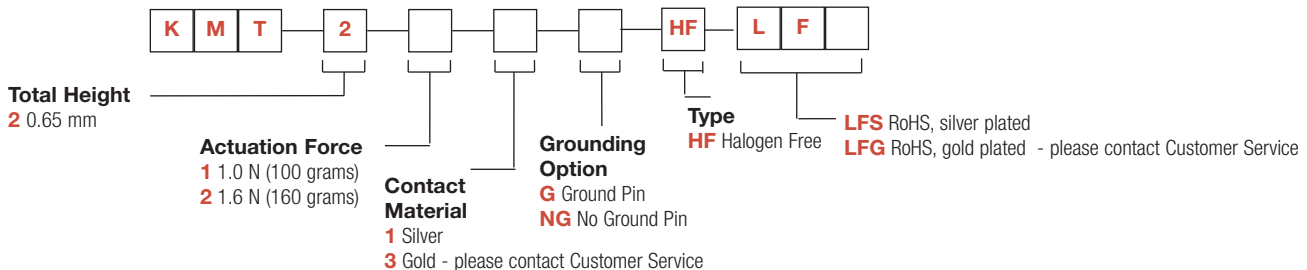

KMT2 Series Nano-Miniature SMT Top Actuated

B

Tactile Switches

KMT Series – No Ground Pin

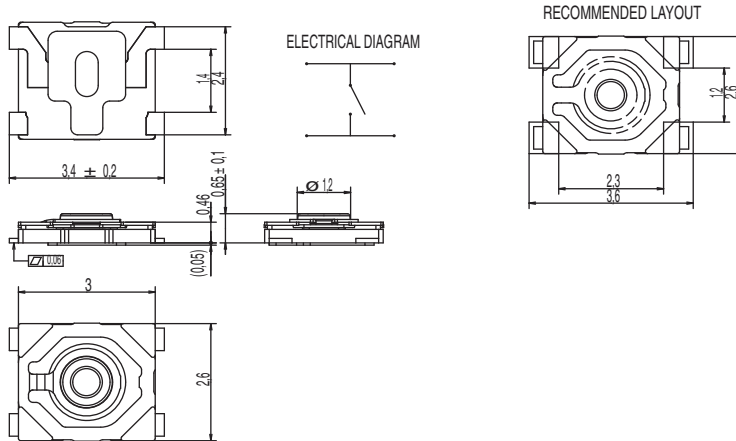

KMT Series – With Ground Pin

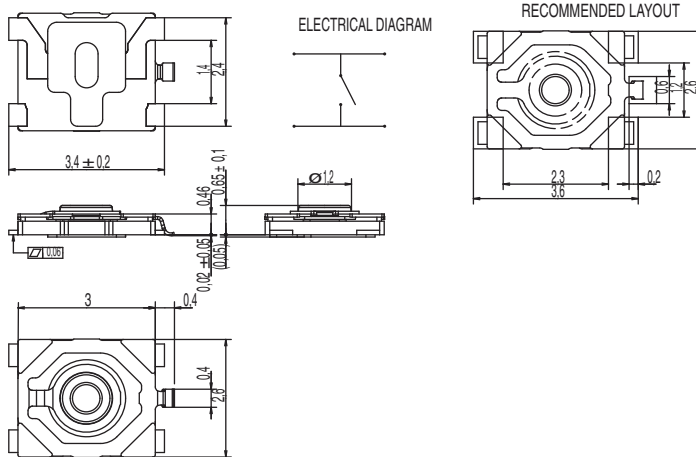

TAPE & REEL

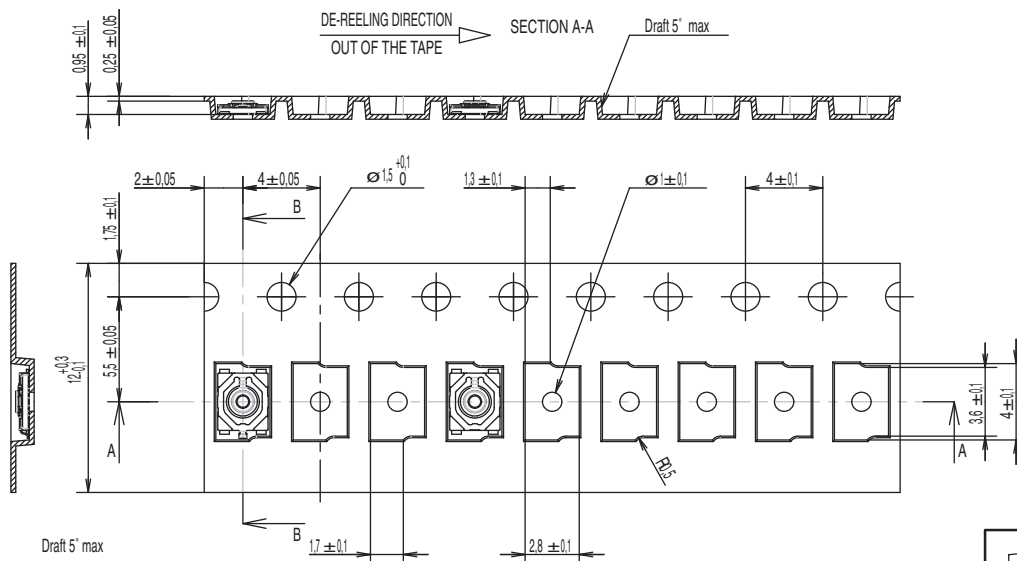

Dimensions are shown: mm
Specifications and dimensions subject to change



KMT0 Series Nano-Miniature SMT Top Actuated

Features

- **Smallest footprint**
- **Smallest thickness with integrated actuator**
- **Extended life cycles**
- **IP68**
- **Ultra low current capabilities**

Typical Applications

- **Mobile Phones**
- **Hearing Aids**
- **MP3 accessories**
- **Bluetooth Headset**
- **Automotive keyless entry system**
- **Smoke and CO detectors**
- **E-readers**
- **Home automation remote controls**



B

Tactile Switches

Specification

FUNCTION: momentary action, normally open
CONTACT ARRANGEMENT: 1 make contact = SPST, N.O.
TERMINALS: J lead type for SMT

Mechanical

TRAVEL (mm): 0.15 ± 0.1

| | Operating force Newtons (grams) | Tactile Feeling | Operating Life |
|--------------|------------------------------------|--------------------|-------------------|
| KMT011NGJLHS | 1.0 (100) ± 25% | ≥ 10% | 300,000 |
| KMT021NGJLHS | 1.6 (160) ± 25% | ≥ 30% | 300,000 |
| KMT071NGJLHS | 2.3 (230) ± 25% | ≥ 30% | 300,000 |
| KMT031NGJLHS | 3.4 (340) ± 25% | ≥ 30% | 300,000 |

| | Operating force Newtons (grams) | Tactile Feeling | Operating Life |
|--------------|------------------------------------|--------------------|-------------------|
| KMT012NGJLHS | 1.0 (100) ± 25% | ≥ 10% | 1,000,000 |
| KMT022NGJLHS | 1.6 (160) ± 25% | ≥ 30% | 600,000 |
| KMT072NGJLHS | 2.3 (230) ± 25% | ≥ 30% | 600,000 |

Electrical

| | |
|------------------------|------------------|
| MAXIMUM POWER: | 0.5 VA |
| MAXIMUM VOLTAGE: | 32 VDC |
| MINIMUM VOLTAGE: | 20 mV |
| MAXIMUM CURRENT DC: | 50 mA |
| MINIMUM CURRENT DC: | 1 mA |
| DIELECTRIC STRENGTH: | ≥ 250 Vrms (1mn) |
| CONTACT RESISTANCE: | ≤ 150 mΩ |
| INSULATION RESISTANCE: | ≥ 50 MΩ |
| BOUNCE TIME: | ≤ 6 ms |

Environmental

OPERATING TEMPERATURE: -40°C to 85°C
STORAGE TEMPERATURE: -55°C (10 days) +85°C (4 days)

Process

SOLDERING: This component is suited to the following methods:
– Infrared Reflow Soldering in accordance with IEC61760-1

Packaging

In reels of 5,000 pieces.
Dimensions of reels according to EIA 481B
External diameter 180 mm

NOTE: Specifications listed above are for switches with standard options.
For information on specific and custom switches, consult Customer Service Center.

Part Number Description

For any part number different from those listed above, please consult your local representative.

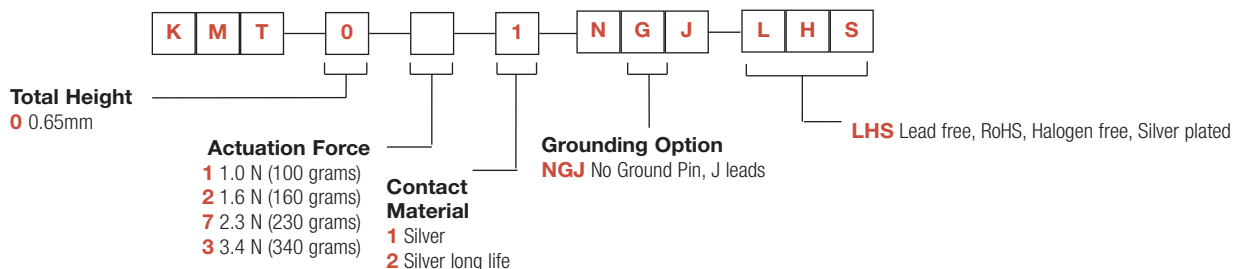

KMT0 Series Nano-Miniature SMT Top Actuated

Minimum actuator diameter is 1.0 mm. It is recommended to enlarge this diameter to a full flat surface covering the switch.

Tactile Switches

B

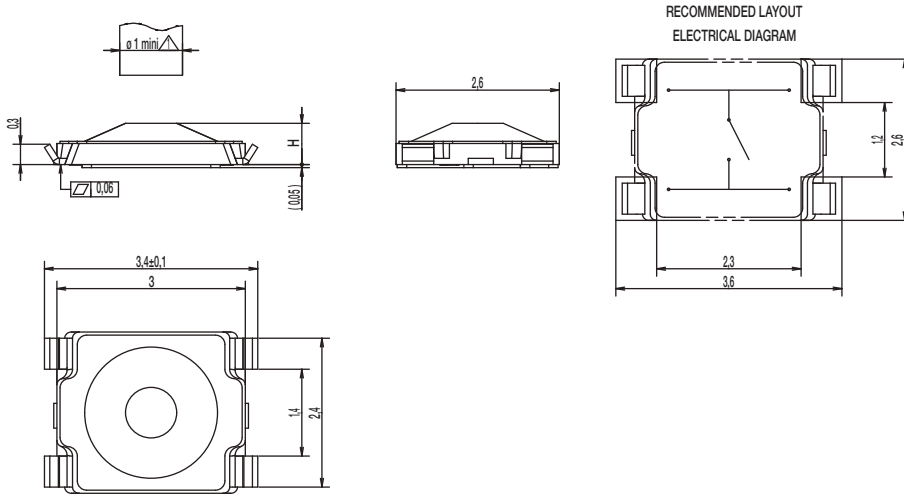

TAPE & REEL

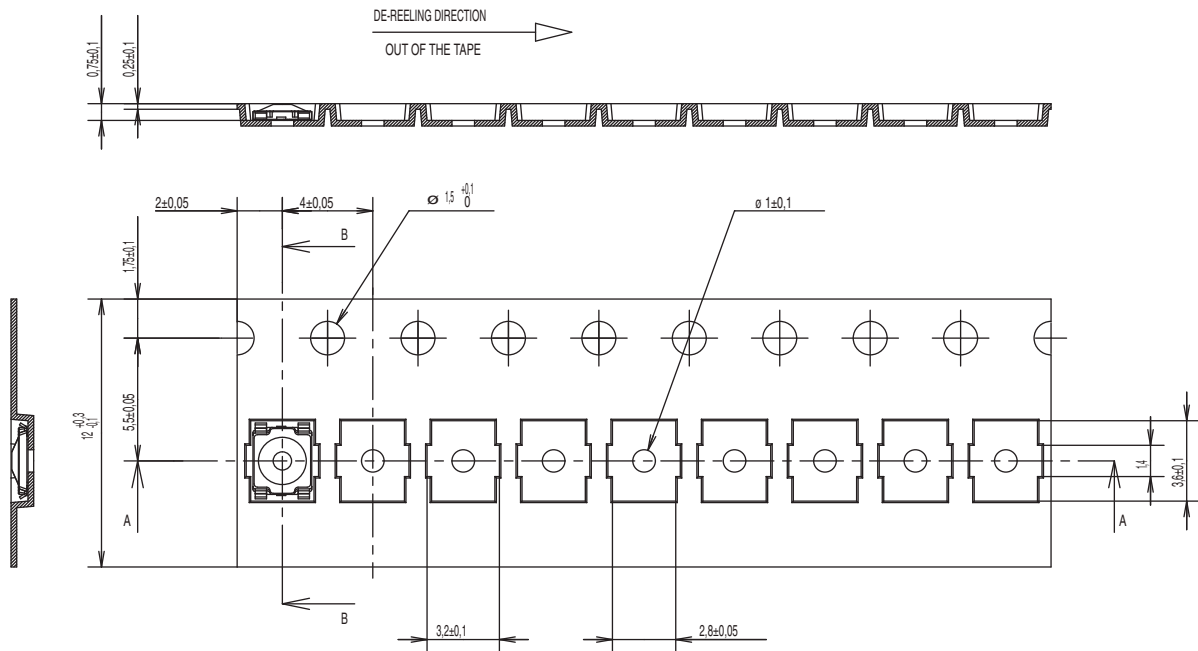

Dimensions are shown: mm
Specifications and dimensions subject to change



KMR 2 Series Microminiature SMT Top Actuated

Features/Benefits

- Small footprint
- 4 actuation forces
- Excellent tactile feel
- Ultra low current capabilities
- IP40

Typical Applications

- Automotive
- Industrial electronics
- Medical equipment

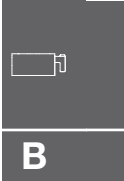

Tactile Switches

Specification

FUNCTION: momentary action
CONTACT ARRANGEMENT: 1 make contact = SPST, N.O.
TERMINALS: Gullwing type for SMT

Mechanical

| Type G and NG See description below | Operating force N (grs) | Operating life (cycles) | Travel (mm) |
|---|-------------------------------|-------------------------------|---------------|
| KMR211 LFS | 1.2 (120) ± 0.30 | 200,000 | 0.20 mm ± 0.1 |
| KMR211 ULC LFS | 1.2 (120) ± 0.30 | 200,000 | 0.20 mm ± 0.1 |
| KMR213 LFG | 1.2 (120) ± 0.30 | 200,000 | 0.20 mm ± 0.1 |
| KMR213 ULC LFG | 1.2 (120) ± 0.30 | 200,000 | 0.20 mm ± 0.1 |
| KMR221 LFS | 2.0 (200) ± 0.50 | 200,000 | 0.25 mm ± 0.1 |
| KMR221 ULC LFS | 2.0 (200) ± 0.50 | 200,000 | 0.25 mm ± 0.1 |
| KMR223 LFG | 2.0 (200) ± 0.50 | 200,000 | 0.25 mm ± 0.1 |
| KMR223 ULC LFG | 2.0 (200) ± 0.50 | 200,000 | 0.25 mm ± 0.1 |
| KMR231 LFS | 3.0 (300) ± 0.75 | 150,000 | 0.25 mm ± 0.1 |
| KMR231 ULC LFS | 3.0 (300) ± 0.75 | 150,000 | 0.25 mm ± 0.1 |
| KMR232 LFS | 3.0 (300) ± 0.75 | 300,000 | 0.25 mm ± 0.1 |
| KMR232 ULC LFS | 3.0 (300) ± 0.75 | 300,000 | 0.25 mm ± 0.1 |
| KMR233 LFG | 3.0 (300) ± 0.75 | 150,000 | 0.25 mm ± 0.1 |
| KMR233 ULC LFG | 3.0 (300) ± 0.75 | 150,000 | 0.25 mm ± 0.1 |
| KMR241 LFS | 4.0 (400) ± 1.00 | 100,000 | 0.30 mm ± 0.1 |
| KMR241 ULC LFS | 4.0 (400) ± 1.00 | 100,000 | 0.30 mm ± 0.1 |
| KMR242 LFS | 4.0 (400) ± 1.00 | 200,000 | 0.30 mm ± 0.1 |
| KMR242 ULC LFS | 4.0 (400) ± 1.00 | 200,000 | 0.30 mm ± 0.1 |
| KMR243 LFG | 4.0 (400) ± 1.00 | 100,000 | 0.30 mm ± 0.1 |
| KMR243 ULC LFG | 4.0 (400) ± 1.00 | 100,000 | 0.30 mm ± 0.1 |

Electrical

| | Silver | Gold |
|------------------------|------------|---------|
| MAXIMUM POWER: | 1 VA | 0.2 VA |
| MAXIMUM VOLTAGE: | 32 VDC | 32 VDC |
| MINIMUM VOLTAGE: | 20 mVDC | 20 mVDC |
| MAXIMUM CURRENT: | 50 mA | 10 mA |
| MINIMUM CURRENT: | 1 mA* | 1 mA* |
| DIELECTRIC STRENGTH: | ≥ 250 Vrms | |
| CONTACT RESISTANCE: | ≤ 100 mΩ | |
| INSULATION RESISTANCE: | ≥ 1GΩ | |
| BOUNCE TIME: | ≤ 3 ms | |

*For ULC version minimum current is 1µA at 1.8 VDC

Environmental

| | Silver | Gold |
|------------------------|---------------|----------------|
| OPERATING TEMPERATURE: | -40°C to 85°C | -40°C to 125°C |
| STORAGE TEMPERATURE: | -55°C to 85°C | -55°C to 125°C |

Process

Infrared Reflow Soldering in accordance with IEC61760-1

Packaging

In reels of 7,000 pieces
External diameter 330 mm ± 2 mm

NOTE: Specifications listed above are for switches with standard options.
For information on specific and custom switches, consult Customer Service Center.

TACTILE FEELING: KMR 2 series with actuation force in 2N - 3N - 4N: ≥ 30%
KMR 2 series with actuation force in 1.2N: ≥ 20%

Part Number Description

For any part number different from those listed above, please consult your local representative.

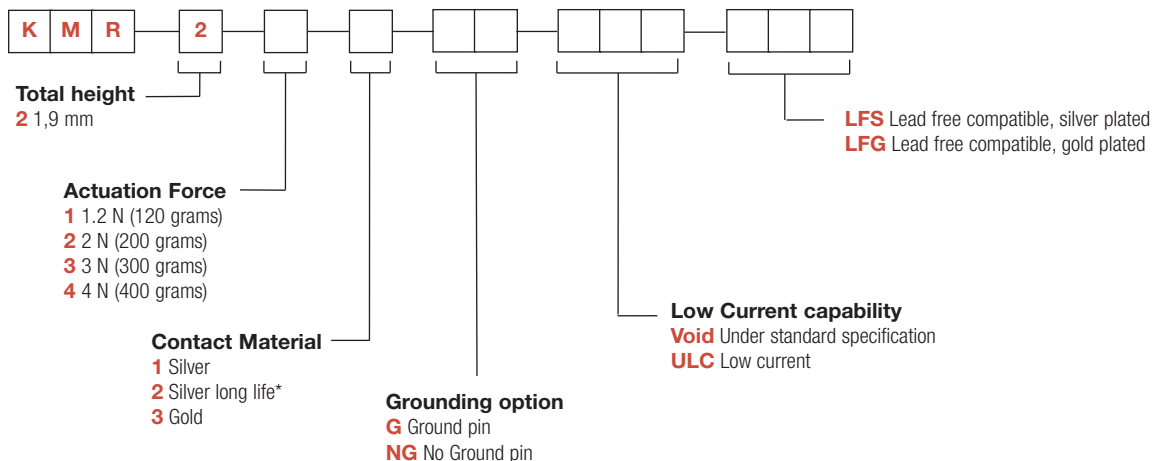

* Silver long life is available in 3N and 4N actuation force. For other versions, please contact Customer Service.



KMR 2 Series Microminiature Tact Switch for SMT

KMR 2 Series - 1.9 mm height

PCB layout shown with ground pin option



B

Tactile Switches

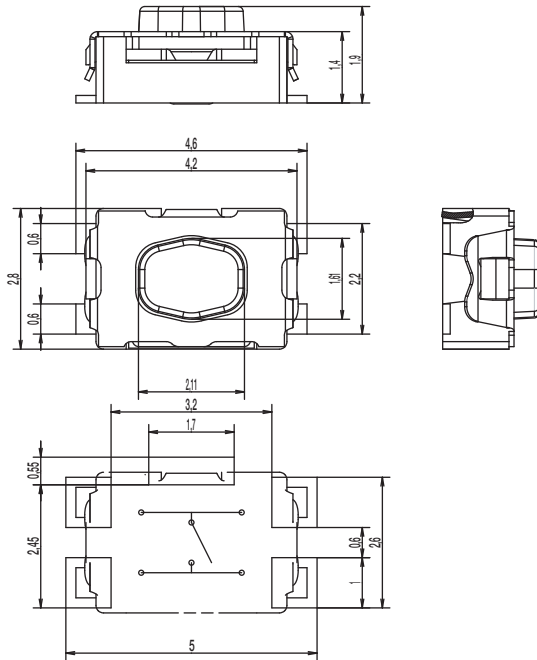

TAPE & REEL

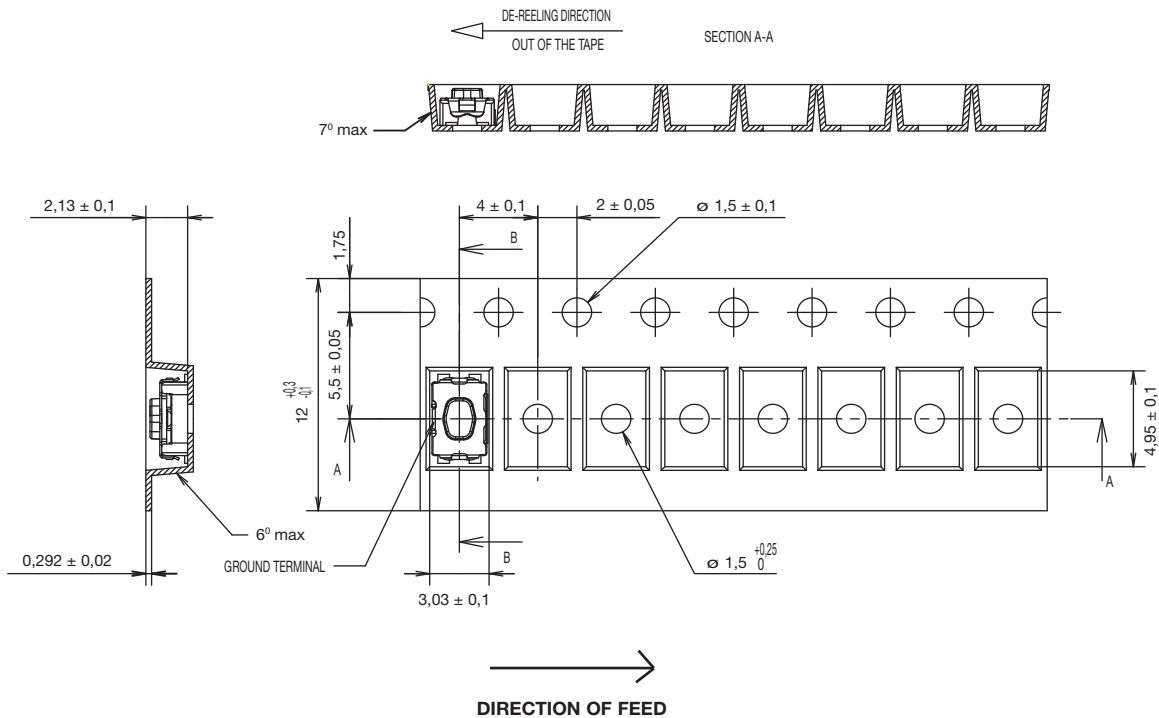

First Angle
Projection

Dimensions are shown: mm
Specifications and dimensions subject to change



KMR 4 Series Microminiature SMT Top Actuated

Features/Benefits

- Small footprint
- 4 actuation forces
- Excellent tactile feel
- Ultra low current capabilities
- IP40

Typical Applications

- Automotive
- Industrial electronics
- Medical equipment



B

Tactile Switches

Specification

FUNCTION: momentary action
CONTACT ARRANGEMENT: 1 make contact = SPST, N.O.
TERMINALS: Gullwing type for SMT

Mechanical

| Type G and NG See description below | Operating force N (grs) | Operating life (cycles) | Travel (mm) |
|---|-------------------------------|-------------------------------|---------------|
| KMR411 LFS | 1.2 (120) ± 0.30 | 100,000 | 0.20 mm ± 0.1 |
| KMR411 ULC LFS | 1.2 (120) ± 0.30 | 100,000 | 0.20 mm ± 0.1 |
| KMR413 LFG | 1.2 (120) ± 0.30 | 100,000 | 0.20 mm ± 0.1 |
| KMR413 ULC LFG | 1.2 (120) ± 0.30 | 100,000 | 0.20 mm ± 0.1 |
| KMR421 LFS | 2.0 (200) ± 0.50 | 100,000 | 0.25 mm ± 0.1 |
| KMR421 ULC LFS | 2.0 (200) ± 0.50 | 100,000 | 0.25 mm ± 0.1 |
| KMR423 LFG | 2.0 (200) ± 0.50 | 100,000 | 0.25 mm ± 0.1 |
| KMR423 ULC LFG | 2.0 (200) ± 0.50 | 100,000 | 0.25 mm ± 0.1 |
| KMR431 LFS | 3.0 (300) ± 0.75 | 100,000 | 0.25 mm ± 0.1 |
| KMR431 ULC LFS | 3.0 (300) ± 0.75 | 100,000 | 0.25 mm ± 0.1 |
| KMR432 LFS | 3.0 (300) ± 0.75 | 300,000 | 0.25 mm ± 0.1 |
| KMR432ULC LFS | 3.0 (300) ± 0.75 | 300,000 | 0.25 mm ± 0.1 |
| KMR433 LFG | 3.0 (300) ± 0.75 | 100,000 | 0.25 mm ± 0.1 |
| KMR433ULC LFG | 3.0 (300) ± 0.75 | 100,000 | 0.25 mm ± 0.1 |
| KMR441 LFS | 4.0 (400) ± 1.00 | 100,000 | 0.30 mm ± 0.1 |
| KMR441 ULC LFS | 4.0 (400) ± 1.00 | 100,000 | 0.30 mm ± 0.1 |
| KMR442 LFS | 4.0 (400) ± 1.00 | 200,000 | 0.30 mm ± 0.1 |
| KMR442 ULC LFS | 4.0 (400) ± 1.00 | 200,000 | 0.30 mm ± 0.1 |
| KMR443 LFG | 4.0 (400) ± 1.00 | 100,000 | 0.30 mm ± 0.1 |
| KMR443 ULC LFG | 4.0 (400) ± 1.00 | 100,000 | 0.30 mm ± 0.1 |

Electrical

| | Silver | Gold |
|------------------------|------------|---------|
| MAXIMUM POWER: | 1 VA | 0.2 VA |
| MAXIMUM VOLTAGE: | 32 VDC | 32 VDC |
| MINIMUM VOLTAGE: | 20 mVDC | 20 mVDC |
| MAXIMUM CURRENT: | 50 mA | 10 mA |
| MINIMUM CURRENT: | 1 mA* | 1 mA* |
| DIELECTRIC STRENGTH: | ≥ 250 Vrms | |
| CONTACT RESISTANCE: | ≤ 100 mΩ | |
| INSULATION RESISTANCE: | ≥ 1GΩ | |
| BOUNCE TIME: | ≤ 3 ms | |

*For ULC version minimum current is 1µA at 1.8 VDC

Environmental

| | Silver | Gold |
|------------------------|---------------|----------------|
| OPERATING TEMPERATURE: | -40°C to 85°C | -40°C to 125°C |
| STORAGE TEMPERATURE: | -55°C to 85°C | -55°C to 125°C |

Process

Infrared Reflow Soldering in accordance with IEC61760-1

Packaging

In reels of 6,000 pieces
External diameter 330 mm ± 2 mm

NOTE: Specifications listed above are for switches with standard options.
For information on specific and custom switches, consult Customer Service Center.

TACTILE FEELING: KMR 4 series with actuation force in 2N - 3N - 4N: ≥ 25%
KMR 4 series with actuation force in 1.2N: ≥ 20%

Part Number Description

For any part number different from those listed above, please consult your local representative.

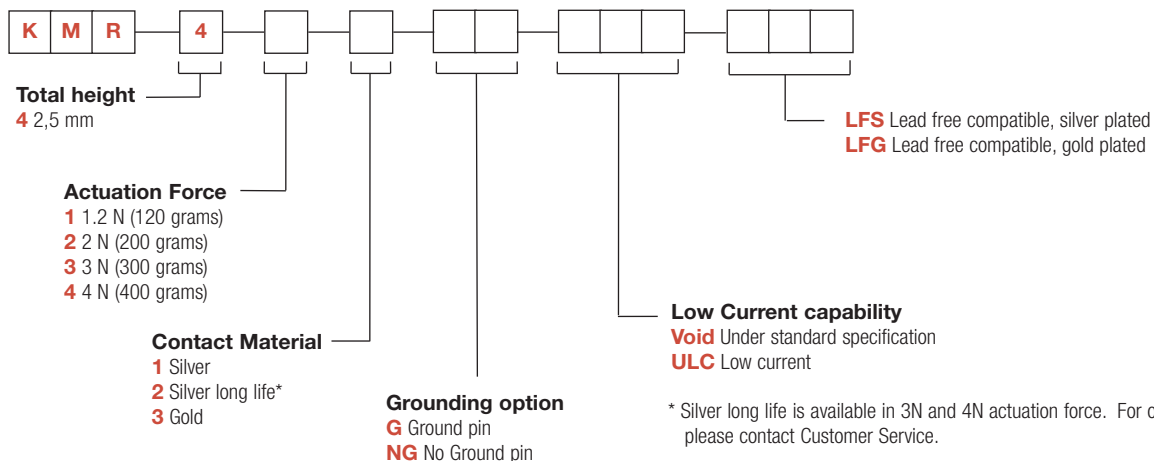

KMR 4 Series Microminiature Tact Switch for SMT

KMR 4 Series - 2.5 mm height

PCB layout shown with ground pin option

B

Tactile Switches

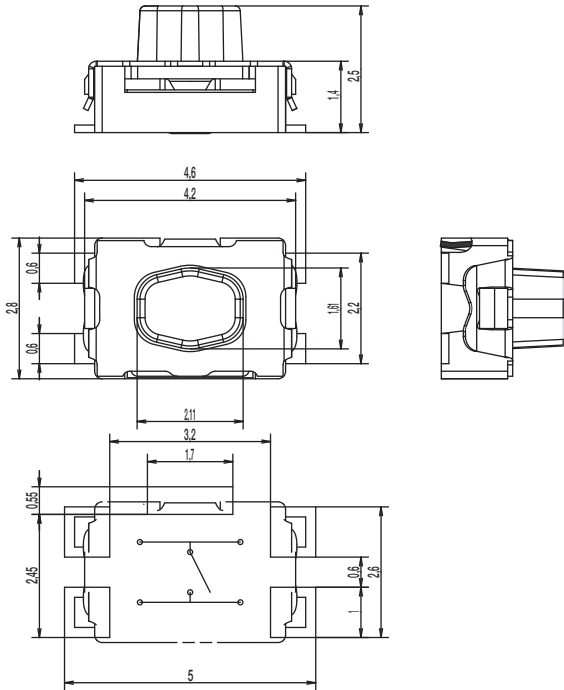

TAPE & REEL

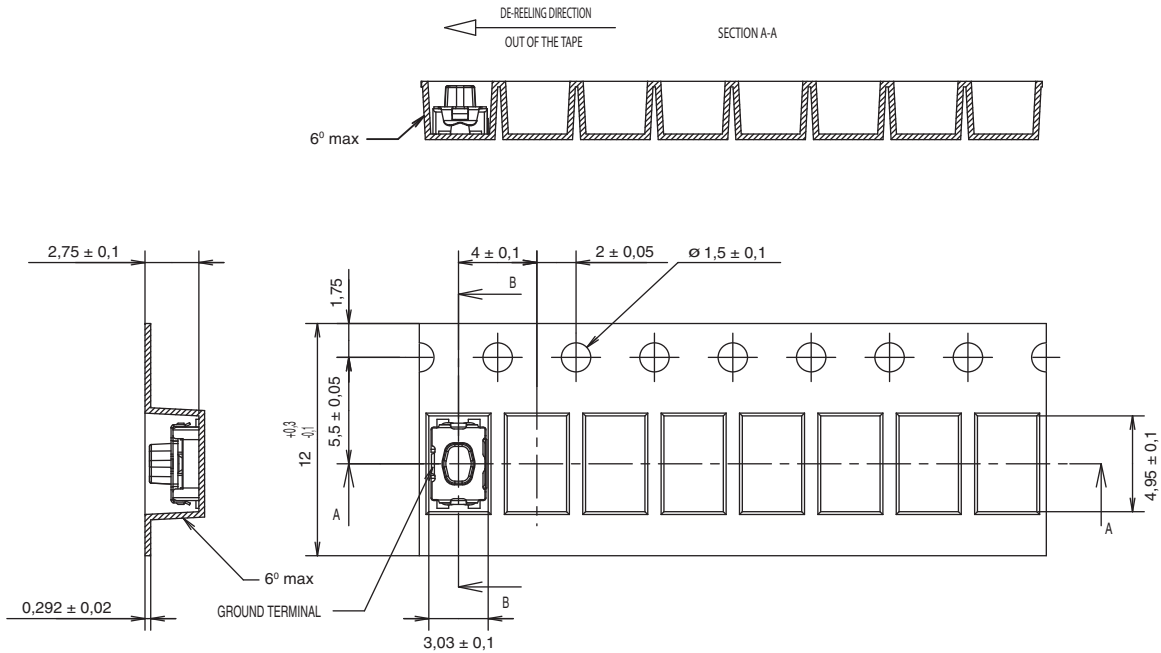

Dimensions are shown: mm
Specifications and dimensions subject to change

KMR 6 Series Microminiature SMT Top Actuated IP67

Features/Benefits

- Watertight IP67
- Standard and long life versions
- No ground pin
- Ultra low current capabilities
- Excellent tactile feel

Typical Applications

- Automotive
- Medical
- Consumer
- Industrial



B

Tactile Switches

Specification

FUNCTION: momentary action
CONTACT ARRANGEMENT: 1 make contact = SPST, N.O.
TERMINALS: Gullwing type for SMT

Mechanical

| Type NG See description below | Operating force N (grs) | Operating life (cycles) | Travel (mm) |
|-------------------------------------|-------------------------------|-------------------------------|---------------|
| KMR611NG LFS | 1.2 (120) ± 0.30 | 200,000 | 0.20 mm ± 0.1 |
| KMR611NG ULC LFS | 1.2 (120) ± 0.30 | 200,000 | 0.20 mm ± 0.1 |
| KMR613NG LFG | 1.2 (120) ± 0.30 | 200,000 | 0.20 mm ± 0.1 |
| KMR613NG ULC LFG | 1.2 (120) ± 0.30 | 200,000 | 0.20 mm ± 0.1 |
| KMR621NG LFS | 2.0 (200) ± 0.50 | 200,000 | 0.25 mm ± 0.1 |
| KMR621NG ULC LFS | 2.0 (200) ± 0.50 | 200,000 | 0.25 mm ± 0.1 |
| KMR623NG LFG | 2.0 (200) ± 0.50 | 200,000 | 0.25 mm ± 0.1 |
| KMR623NG ULC LFG | 2.0 (200) ± 0.50 | 200,000 | 0.25 mm ± 0.1 |
| KMR631NG LFS | 3.0 (300) ± 0.75 | 150,000 | 0.25 mm ± 0.1 |
| KMR631NG ULC LFS | 3.0 (300) ± 0.75 | 150,000 | 0.25 mm ± 0.1 |
| KMR632NG LFS | 3.0 (300) ± 0.75 | 300,000 | 0.25 mm ± 0.1 |
| KMR632NG ULC LFS | 3.0 (300) ± 0.75 | 300,000 | 0.25 mm ± 0.1 |
| KMR633NG LFG | 3.0 (300) ± 0.75 | 150,000 | 0.25 mm ± 0.1 |
| KMR633NG ULC LFG | 3.0 (300) ± 0.75 | 150,000 | 0.25 mm ± 0.1 |
| KMR641NG LFS | 4.0 (400) ± 1.00 | 100,000 | 0.30 mm ± 0.1 |
| KMR641NG ULC LFS | 4.0 (400) ± 1.00 | 100,000 | 0.30 mm ± 0.1 |
| KMR642NG LFS | 4.0 (400) ± 1.00 | 200,000 | 0.30 mm ± 0.1 |
| KMR642NG ULC LFS | 4.0 (400) ± 1.00 | 200,000 | 0.30 mm ± 0.1 |
| KMR643NG LFG | 4.0 (400) ± 1.00 | 100,000 | 0.30 mm ± 0.1 |
| KMR643NG ULC LFG | 4.0 (400) ± 1.00 | 100,000 | 0.30 mm ± 0.1 |

Electrical

| | Silver | Gold |
|------------------------|------------|---------|
| MAXIMUM POWER: | 1 VA | 0.2 VA |
| MAXIMUM VOLTAGE: | 32 VDC | 32 VDC |
| MINIMUM VOLTAGE: | 20 mVDC | 20 mVDC |
| MAXIMUM CURRENT: | 50 mA | 10 mA |
| MINIMUM CURRENT: | 1 mA* | 1 mA* |
| DIELECTRIC STRENGTH: | ≥ 250 Vrms | |
| CONTACT RESISTANCE: | ≤ 100 mΩ | |
| INSULATION RESISTANCE: | ≥ 1GΩ | |
| BOUNCE TIME: | ≤ 3 ms | |

*For ULC version minimum current is 1µA at 1.8 VDC

Environmental

| | Silver | Gold |
|------------------------|---------------|----------------|
| OPERATING TEMPERATURE: | -40°C to 85°C | -40°C to 125°C |
| STORAGE TEMPERATURE: | -55°C to 85°C | -55°C to 125°C |

Process

Infrared Reflow Soldering in accordance with IEC61760-1

Packaging

In reels of 7,000 pieces
External diameter 330 mm ± 2 mm

NOTE: Specifications listed above are for switches with standard options.
For information on specific and custom switches, consult Customer Service Center.

TACTILE FEELING: KMR 6 series with actuation force in 2N - 3N - 4N: ≥ 30%
KMR 6 series with actuation force in 1.2N: ≥ 20%

Part Number Description

For any part number different from those listed above, please consult your local representative.

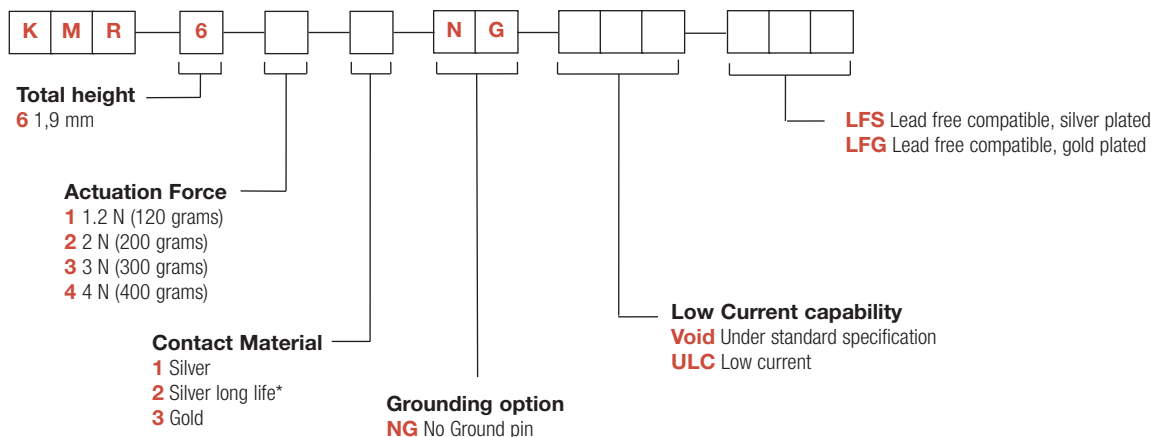

* Silver long life is available in 3N and 4N actuation force. For other versions, please contact Customer Service.



Dimensions are shown: mm
Specifications and dimensions subject to change

KMR 6 Series Microminiature SMT Top Actuated IP67

KMR 6 Series - 1.9 mm height

PCB layout shown with ground pin option

B

Tactile Switches

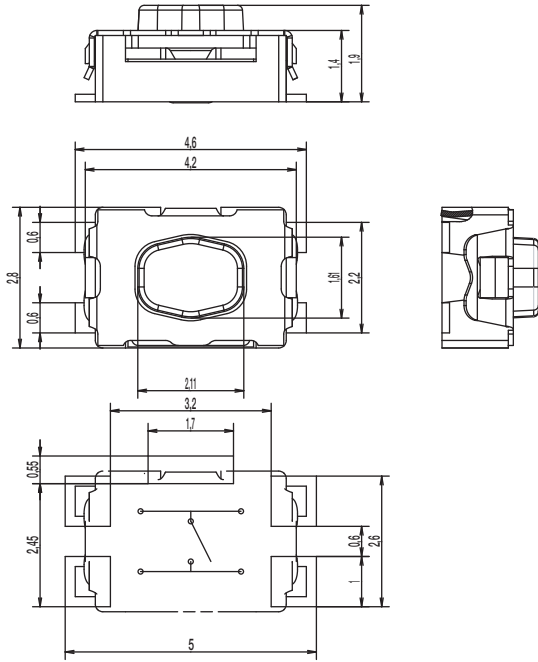

TAPE & REEL

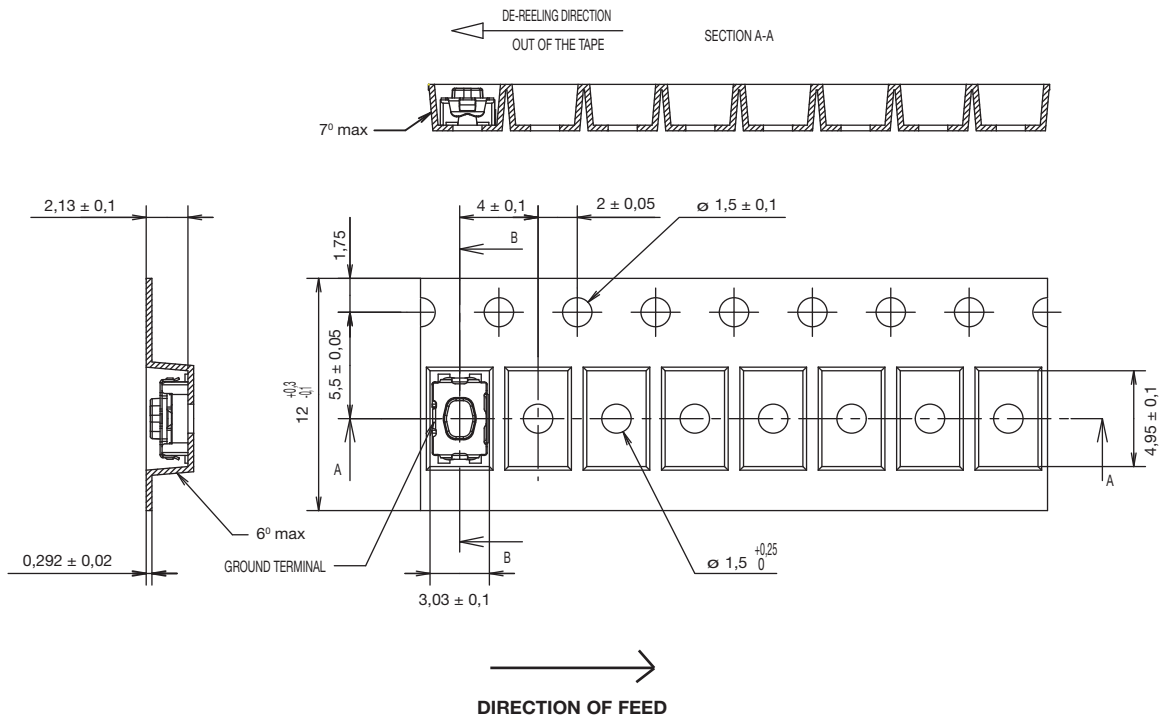

KMR 7 Series Microminiature SMT Top Actuated IP67

Features/Benefits

- Watertight IP67
- Standard and long life versions
- No ground pin
- Ultra low current capabilities
- Excellent tactile feel

Typical Applications

- Automotive
- Medical
- Consumer
- Industrial



B

Tactile Switches

Specification

FUNCTION: momentary action
CONTACT ARRANGEMENT: 1 make contact = SPST, N.O.
TERMINALS: Gullwing type for SMT

Mechanical

| Type NG See description below | Operating force N (grs) | Operating life (cycles) | Travel (mm) |
|-------------------------------------|-------------------------------|-------------------------------|---------------|
| KMR711NG LFS | 1.2 (120) ± 0.30 | 100,000 | 0.20 mm ± 0.1 |
| KMR711NG ULC LFS | 1.2 (120) ± 0.30 | 100,000 | 0.20 mm ± 0.1 |
| KMR713NG LFG | 1.2 (120) ± 0.30 | 100,000 | 0.20 mm ± 0.1 |
| KMR713NG ULC LFG | 1.2 (120) ± 0.30 | 100,000 | 0.20 mm ± 0.1 |
| KMR721NG LFS | 2.0 (200) ± 0.50 | 100,000 | 0.25 mm ± 0.1 |
| KMR721NG ULC LFS | 2.0 (200) ± 0.50 | 100,000 | 0.25 mm ± 0.1 |
| KMR723NG LFG | 2.0 (200) ± 0.50 | 100,000 | 0.25 mm ± 0.1 |
| KMR723NG ULC LFG | 2.0 (200) ± 0.50 | 100,000 | 0.25 mm ± 0.1 |
| KMR731NG LFS | 3.0 (300) ± 0.75 | 100,000 | 0.25 mm ± 0.1 |
| KMR731NG ULC LFS | 3.0 (300) ± 0.75 | 100,000 | 0.25 mm ± 0.1 |
| KMR732NG LFS | 3.0 (300) ± 0.75 | 300,000 | 0.25 mm ± 0.1 |
| KMR732NG ULC LFS | 3.0 (300) ± 0.75 | 300,000 | 0.25 mm ± 0.1 |
| KMR733NG LFG | 3.0 (300) ± 0.75 | 100,000 | 0.25 mm ± 0.1 |
| KMR733NG ULC LFG | 3.0 (300) ± 0.75 | 100,000 | 0.25 mm ± 0.1 |
| KMR741NG LFS | 4.0 (400) ± 1.00 | 100,000 | 0.30 mm ± 0.1 |
| KMR741NG ULC LFS | 4.0 (400) ± 1.00 | 100,000 | 0.30 mm ± 0.1 |
| KMR742NG LFS | 4.0 (400) ± 1.00 | 200,000 | 0.30 mm ± 0.1 |
| KMR742NG ULC LFS | 4.0 (400) ± 1.00 | 200,000 | 0.30 mm ± 0.1 |
| KMR743NG LFG | 4.0 (400) ± 1.00 | 100,000 | 0.30 mm ± 0.1 |
| KMR743NG ULC LFG | 4.0 (400) ± 1.00 | 100,000 | 0.30 mm ± 0.1 |

Electrical

| | Silver | Gold |
|------------------------|------------|---------|
| MAXIMUM POWER: | 1 VA | 0.2 VA |
| MAXIMUM VOLTAGE: | 32 VDC | 32 VDC |
| MINIMUM VOLTAGE: | 20 mVDC | 20 mVDC |
| MAXIMUM CURRENT: | 50 mA | 10 mA |
| MINIMUM CURRENT: | 1 mA* | 1 mA* |
| DIELECTRIC STRENGTH: | ≥ 250 Vrms | |
| CONTACT RESISTANCE: | ≤ 100 mΩ | |
| INSULATION RESISTANCE: | ≥ 1GΩ | |
| BOUNCE TIME: | ≤ 3 ms | |

*For ULC version minimum current is 1µA at 1.8 VDC

Environmental

| | Silver | Gold |
|------------------------|---------------|----------------|
| OPERATING TEMPERATURE: | -40°C to 85°C | -40°C to 125°C |
| STORAGE TEMPERATURE: | -55°C to 85°C | -55°C to 125°C |

Process

Infrared Reflow Soldering in accordance with IEC61760-1

Packaging

In reels of 6,000 pieces
External diameter 330 mm ± 2 mm

NOTE: Specifications listed above are for switches with standard options.
For information on specific and custom switches, consult Customer Service Center.

TACTILE FEELING: KMR 7 series with actuation force in 2N - 3N - 4N: ≥ 25%
KMR 7 series with actuation force in 1.2N: ≥ 20%

Part Number Description

For any part number different from those listed above, please consult your local representative.

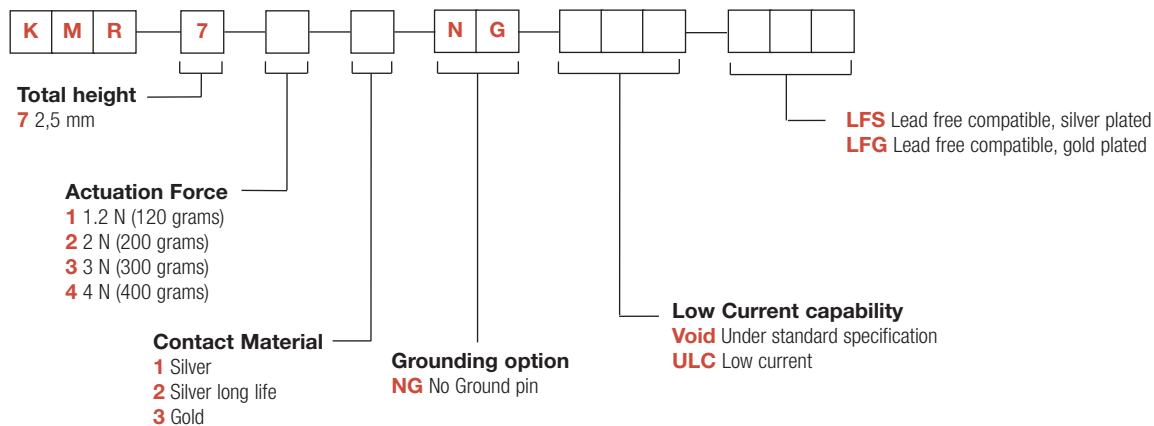

* Silver long life is available in 3N and 4N actuation force. For other versions, please contact Customer Service.



Dimensions are shown: mm
Specifications and dimensions subject to change

KMR 7 Series Microminiature SMT Top Actuated IP67

KMR 7 Series - 2.5 mm height

PCB layout shown with ground pin option

B

Tactile Switches

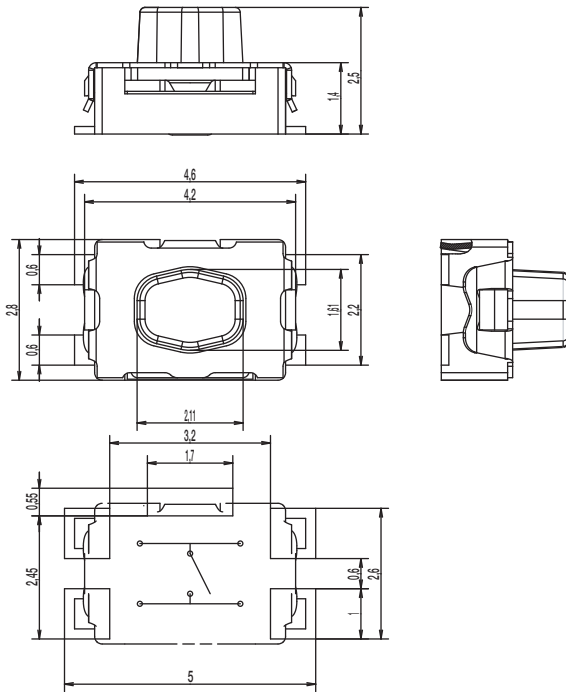

TAPE & REEL

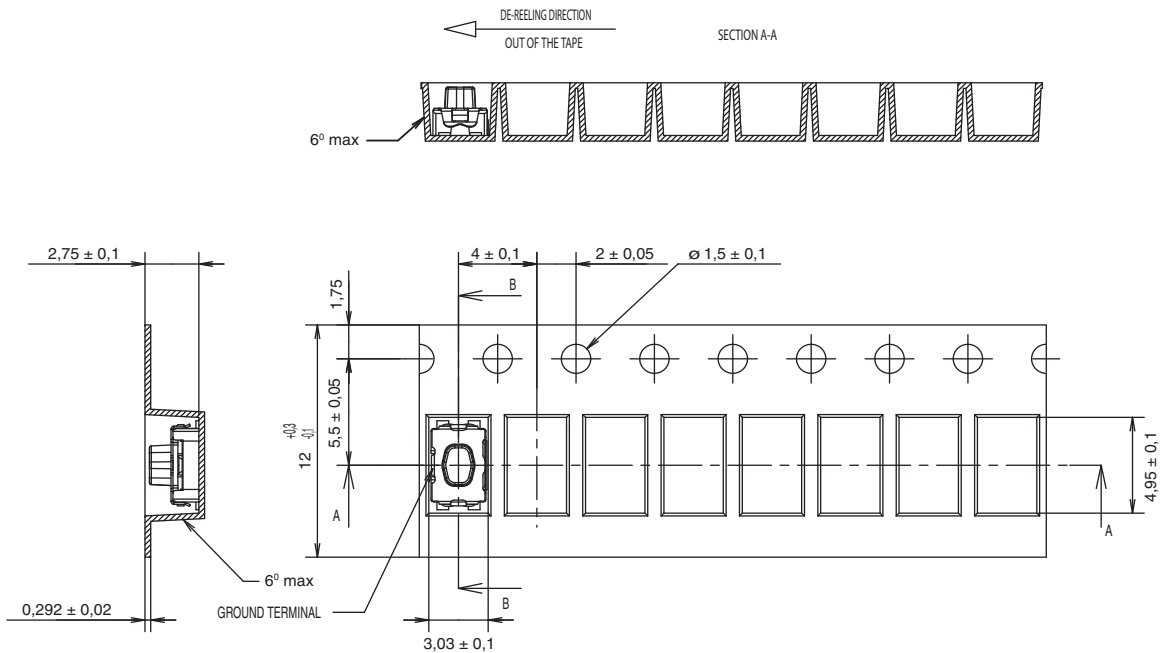

KMR 8 Series Microminiature SMT Top Actuated

Features/Benefits

- Small footprint
- 3 actuation forces
- Excellent tactile feel
- Hard actuator
- IP40

Typical Applications

- Automotive
- Mobile phones
- Industrial electronics
- Medical equipment



B

Tactile Switches

Specification

FUNCTION: momentary action
CONTACT ARRANGEMENT: 1 make contact = SPST, N.O.
TERMINALS: Gullwing type for SMT

Mechanical

| Type G and NG See description below | Operating force N (grs) | Operating life (cycles) | Travel (mm) |
|---|-------------------------------|-------------------------------|---------------|
| KMR811G LFS | 1.2 (120) ± 0.30 | 200,000 | 0.20 mm ± 0.1 |
| KMR821G LFS | 2.0 (200) ± 0.50 | 200,000 | 0.25 mm ± 0.1 |
| KMR831G LFS | 3.0 (300) ± 0.75 | 150,000 | 0.25 mm ± 0.1 |
| KMR831NG ULC LFS | 3.0 (300) ± 0.75 | 150,000 | 0.25 mm ± 0.1 |

TACTILE FEELING:

KMR 8 series with actuation force in 2N - 3N - 4N: ≥ 30%
KMR 8 series with actuation force in 1.2N: ≥ 20%

Electrical

| | |
|------------------------|------------|
| | Silver |
| MAXIMUM POWER: | 1 VA |
| MAXIMUM VOLTAGE: | 32 VDC |
| MINIMUM VOLTAGE: | 20 mVDC |
| MAXIMUM CURRENT: | 50 mA |
| MINIMUM CURRENT: | 1 mA* |
| DIELECTRIC STRENGTH: | ≥ 250 Vrms |
| CONTACT RESISTANCE: | ≤ 100 mΩ |
| INSULATION RESISTANCE: | ≥ 1GΩ |
| BOUNCE TIME: | ≤ 3 ms |

*For ULC version minimum current is 1µA at 1.8 VDC

Environmental

| | |
|------------------------|---------------|
| | Silver |
| OPERATING TEMPERATURE: | -40°C to 85°C |
| STORAGE TEMPERATURE: | -55°C to 85°C |

Process

Infrared Reflow Soldering in accordance with IEC61760-1

Packaging

In reels of 7,000 pieces
External diameter 330 mm ± 2 mm

NOTE: Specifications listed above are for switches with standard options.
For information on specific and custom switches, consult Customer Service Center.

Part Number Description

For any part number different from those listed above, please consult your local representative.

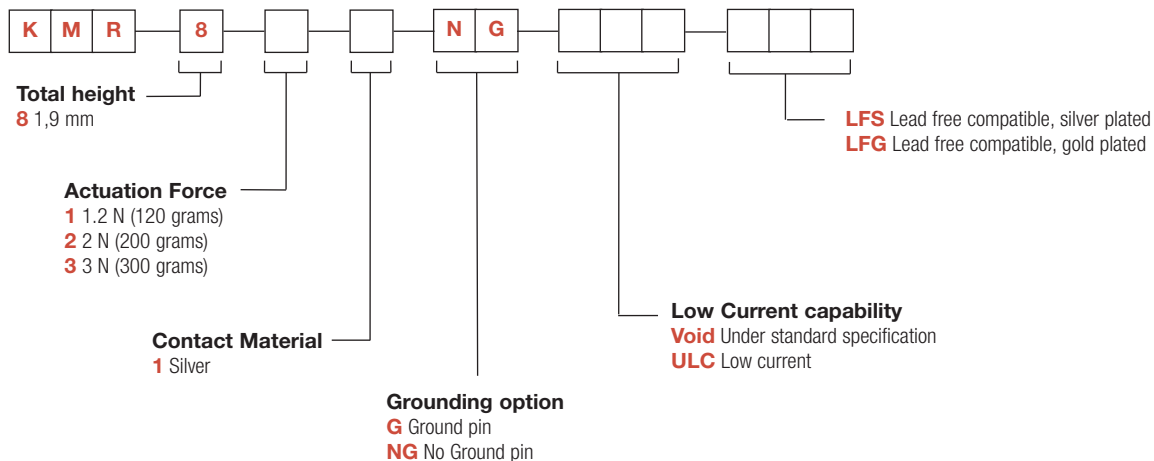

KMR 8 Series Microminiature SMT Top Actuated

G - Ground Pin

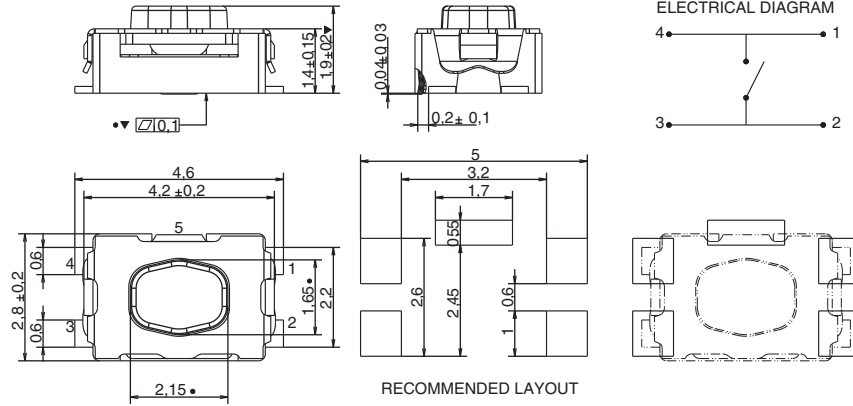

NG - No Ground Pin

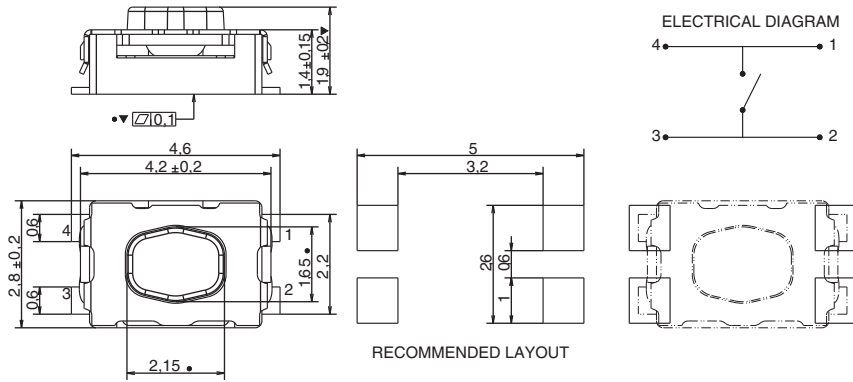

TAPE & REEL

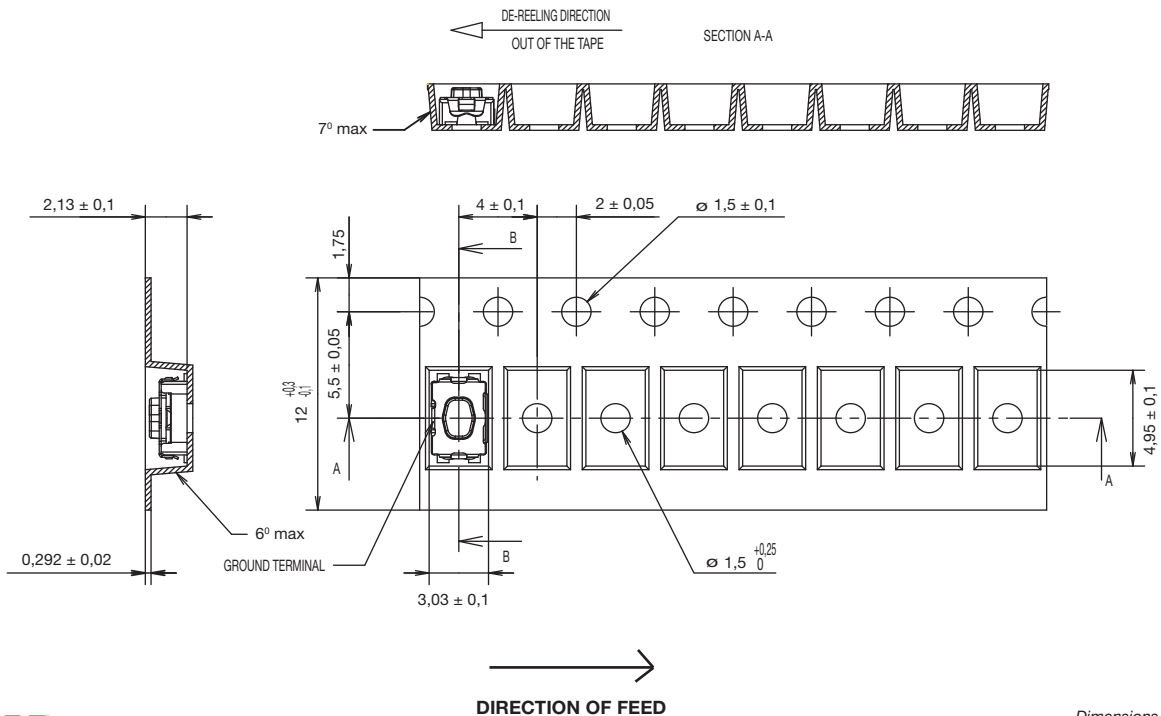

KMS Series Microminiature SMT Side Actuated

Features/Benefits

- Compact size
- Excellent tactile feel
- ESD protection
- Positioning pegs for stability
- RoHS compliant and compatible

Typical Applications

- Mobile phones
- Medical handheld monitors
- Consumer electronics
- Telecommunication networks



B

Tactile Switches

Specification

FUNCTION: Momentary
CONTACT ARRANGEMENT: SPST, N.O.
TERMINALS: Gullwing type for SMT
IP40 Sealed

Mechanical

OVERLOAD: 20N
TACTILE FEELING: 15% min. for the 2N version
25% min for the 2.5N version

| Type | Operating force Newtons (grams) | Operating life (operations) | Travel |
|------------|------------------------------------|--------------------------------|-------------|
| KMS221G/GP | 2N (200) ± 0.5 | 100 K cycles | 0,25 ± 0,15 |
| KMS223G/GP | 2N (200) ± 0.5 | 100 K cycles | 0,25 ± 0,15 |
| KMS231G/GP | 3N (300) ± 0.6 | 100 K cycles | 0,3 ± 0,15 |
| KMS233G/GP | 3N (300) ± 0.6 | 100 K cycles | 0,3 ± 0,15 |

Note: Specifications listed above are for switches with standard options. For information on specific and custom switches, consult Customer Service Center.

Packaging

Tape and reels in reels of 3,000 pieces.
External diameter 330mm ± 2mm.

Electrical

| | Silver | Gold |
|--|--------|--------|
| MAXIMUM POWER: | 1 VA | 0.2 VA |
| MAXIMUM VOLTAGE: | 32 VDC | 32 VDC |
| MAXIMUM CURRENT DC: | 50 mA | 10 mA |
| MINIMUM CURRENT DC: | 1 mA | 1 mA |
| DIELECTRIC STRENGTH: 250 VDC | | |
| CONTACT RESISTANCE: ≤100 mΩ | | |
| INSULATION RESISTANCE: 10 ⁹ Ω | | |
| BOUNCE TIME: ≤ 3 ms | | |

Environmental

| | Silver | Gold |
|------------------------|---------------|----------------|
| OPERATING TEMPERATURE: | -40°C to 85°C | -40°C to 125°C |
| STORAGE TEMPERATURE: | -55°C to 85°C | -55°C to 125°C |

Process

Infrared reflow soldering in accordance with IEC 61760-1

How To Order

Our easy build-a-switch concept allows you to mix and match options to create the switch you need. To order, select desired option from each category and place it in the appropriate box.

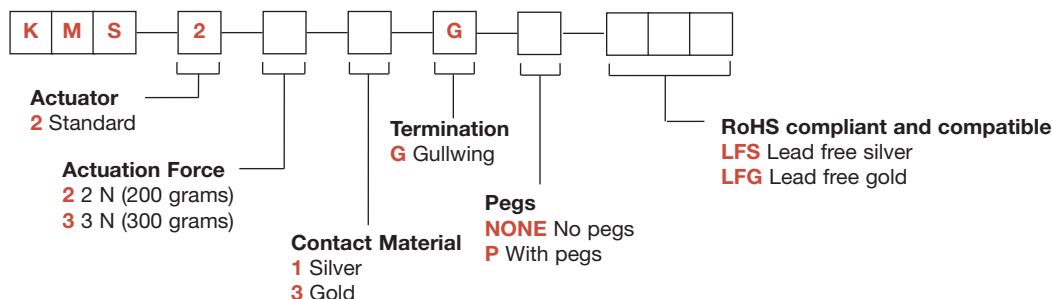

KMS Series Microminiature SMT Side Actuated

Tactile Switches

B

KMS

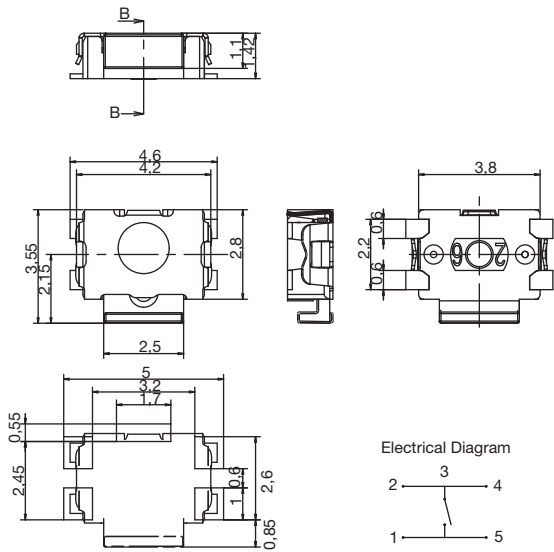

KMS WITH PEGS

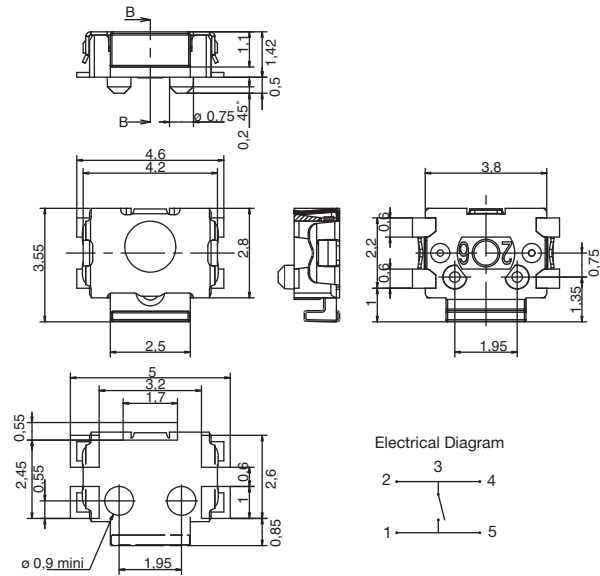

TAPE & REEL

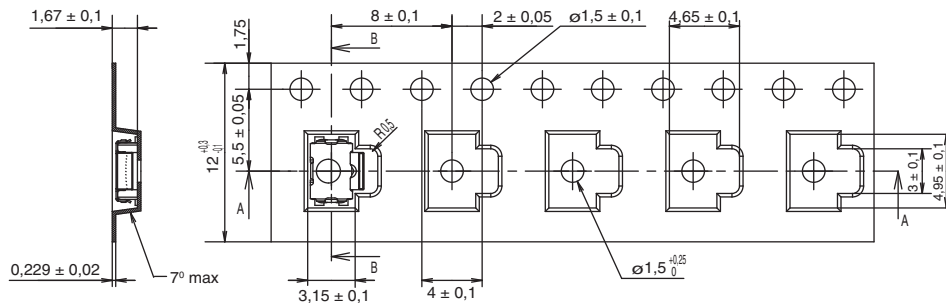

WITH PEGS

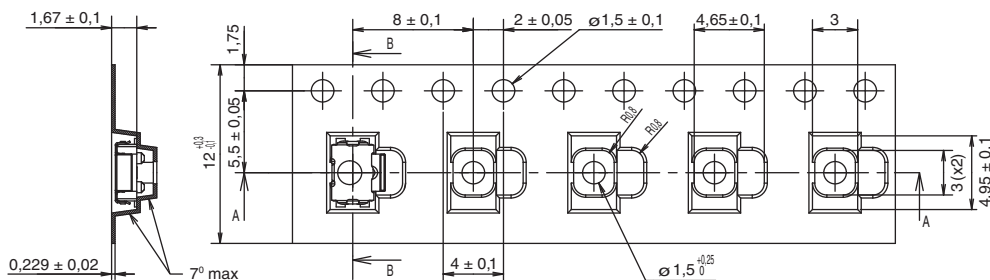

→
DIRECTION OF FEED



First Angle
Projection

Dimensions are shown: mm
Specifications and dimensions subject to change



PTS 525 Series Microminiature Tact Switch for SMT

Features/Benefits

- 0.8 & 1.5 mm actuator height
- Ruggedized package in a compact size
- High number of cycles

Typical Applications

- Consumer products
- Instrumentation
- Remote controls



B

Tactile Switches

Specification

FUNCTION: Momentary action
CONTACT ARRANGEMENT: 1 make contact = SPST, N.O.

Electrical

MAXIMUM VOLTAGE: 15 VDC
MAXIMUM CURRENT DC: 20 mA
DIELECTRIC STRENGTH: 250 VA C (1mn)
CONTACT RESISTANCE: $\leq 100 \text{ m}\Omega$
INSULATION RESISTANCE: $\geq 100 \text{ M}\Omega$
BOUNCE TIME: $\leq 10 \text{ ms}$

Environmental

OPERATING TEMPERATURE: -20°C to 70°C

Process

SOLDERING: This component is suited to the following methods:
Infrared Reflow Soldering in accordance with IEC61760-1

Packaging

Switches in reels of:
5,000 pieces in 0.8 mm height
4,000 pieces in 1.5 mm height
Dimensions of reels according to EIA 481B
External diameter 330 mm

NOTE: Specifications listed above are for switches with standard options.
For information on specific and custom switches, consult Customer Service Center.

How To Order

Please see chart below for full part numbers.

| Part Number | Height (mm) | Leads Shape | Ground Pin | Force | Travel (mm) | Operating Life |
|--------------------------|-------------|-------------|------------|--------------------|----------------|----------------|
| PTS525 SM08 SMTR 2 LFS | 0.8 | G | No | 160 gf \pm 50 gf | 0.25 \pm 0.2 | 1,000,000 |
| PTS525 SK08 SMTR 2 LFS | 0.8 | G | No | 260 gf \pm 50 gf | 0.25 \pm 0.2 | 200,000 |
| PTS525 SM15 SMTR 2 LFS | 1.5 | G | No | 160 gf \pm 50 gf | 0.25 \pm 0.2 | 1,000,000 |
| PTS525 SK15 SMTR 2 LFS | 1.5 | G | No | 260 gf \pm 50 gf | 0.25 \pm 0.2 | 500,000 |
| PTS525 SMG15 SMTR 2 LFS | 1.5 | G | Yes | 160 gf \pm 50 gf | 0.25 \pm 0.2 | 1,000,000 |
| PTS525 SKG15 SMTR 2 LFS | 1.5 | G | Yes | 260 gf \pm 50 gf | 0.25 \pm 0.2 | 500,000 |
| PTS525 SMG15J SMTR 2 LFS | 1.5 | J | Yes | 160 gf \pm 50 gf | 0.25 \pm 0.2 | 1,000,000 |
| PTS525 SKG15J SMTR 2 LFS | 1.5 | J | Yes | 260 gf \pm 50 gf | 0.25 \pm 0.2 | 500,000 |



Dimensions are shown: mm
Specifications and dimensions subject to change

PTS 525 Series Microminiature Tact Switch for SMT

PTS525 SM08 SMTR2 LFS
PTS525 SK08 SMTR2 LFS

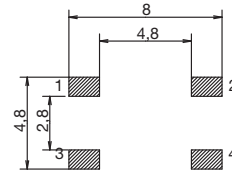
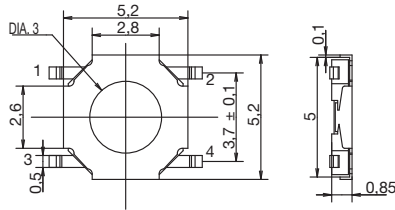
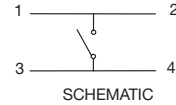
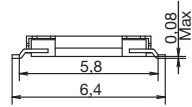

RECOMMENDED PCB LAYOUT

PTS525 SM15 SMTR2 LFS
PTS525 SK15 SMTR2 LFS

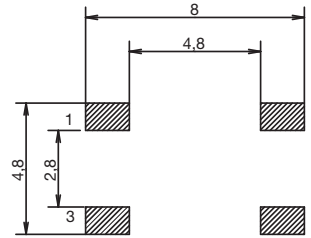
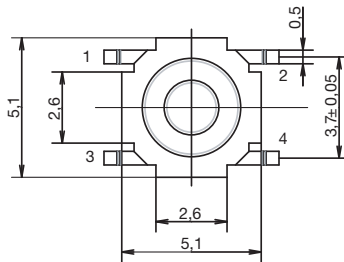
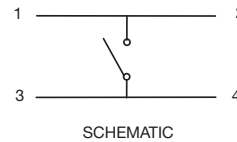
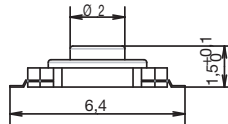

RECOMMENDED PCB LAYOUT

PTS525 SMG15 SMTR2 LFS
PTS525 SKG15 SMTR2 LFS

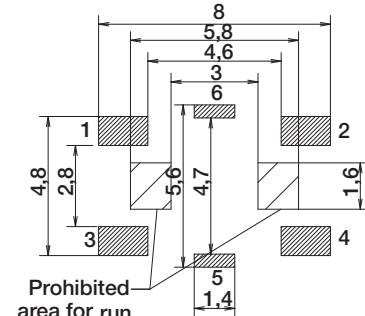
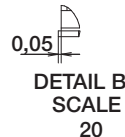
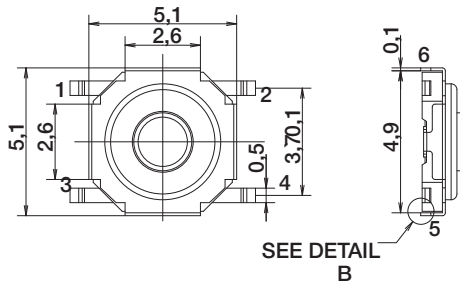
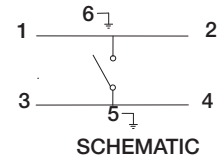
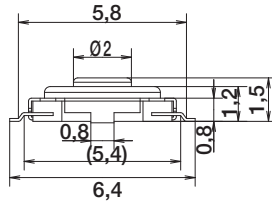

RECOMMENDED PCB LAYOUT

*Dimensions are shown: mm
Specifications and dimensions subject to change*

PTS 525 Series Microminiature Tact Switch for SMT

PTS525 SMG15J SMTR2 LFS
PTS525 SKG15J SMTR2 LFS

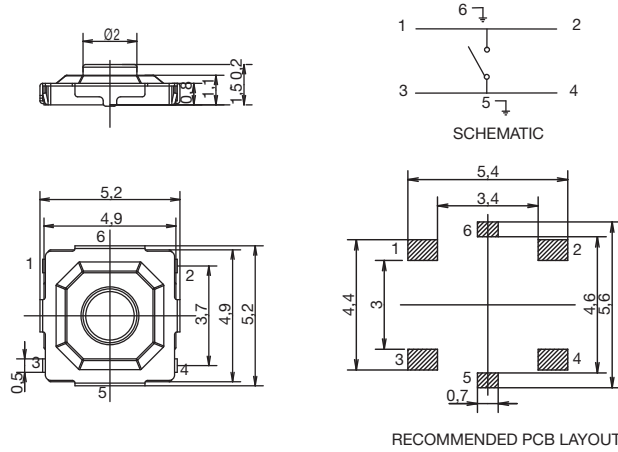

B

Tactile Switches

TAPE & REEL

0.8 mm height
5,000 pieces per reel

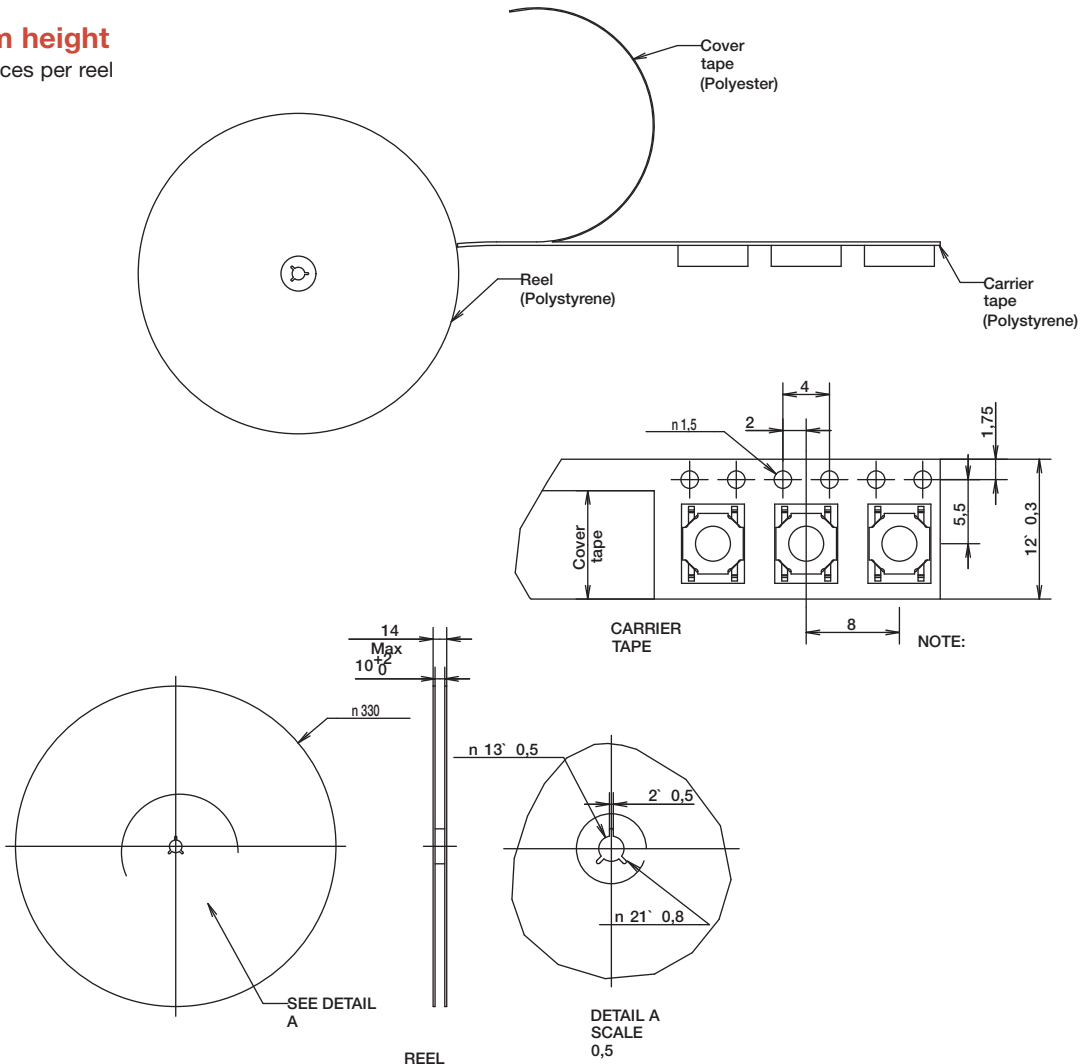

Dimensions are shown: mm
Specifications and dimensions subject to change

PTS 525 Series Microminiature Tact Switch for SMT

TAPE & REEL

1.5 mm height

4,000 pieces per reel



B

Tactile Switches

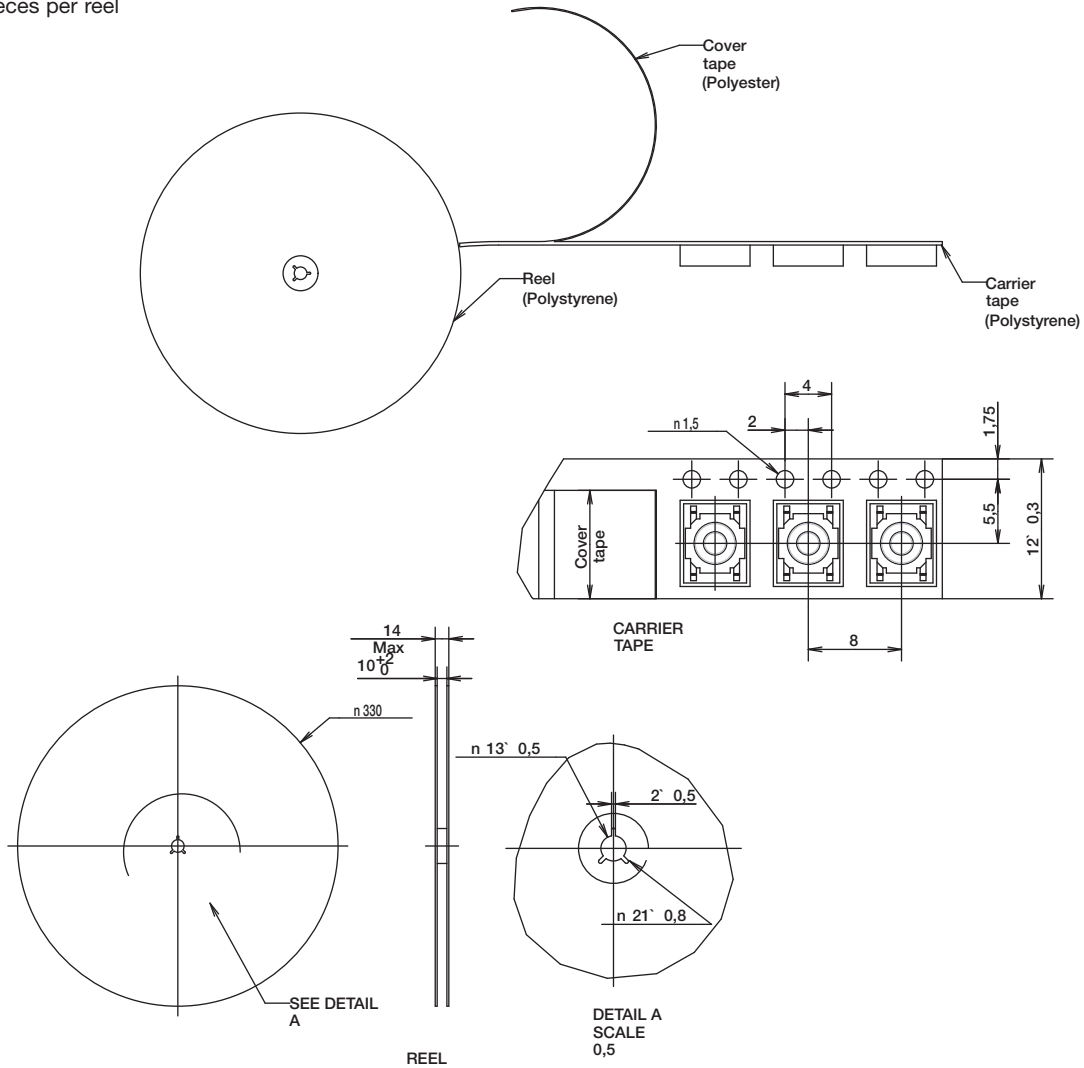

First Angle
Projection

Dimensions are shown: mm
Specifications and dimensions subject to change



PTS 530 Series Ultra Low Profile SMT Top Actuated

Features/Benefits

- 4.5 x 4.5 mm footprint
- 0.55 mm thickness
- High number of cycles
- Symbol line identification

Typical Applications

- MP3 accessories
- Bluetooth headset
- Remote controls
- Garage door opener



Specifications

FUNCTION: momentary action
 CONTACT ARRANGEMENT: 1 make contact = SPST N.O.
 TERMINALS: Gullwing for SMT
 TRAVEL: 0.2mm - 0.1 /+ 0.15mm

| Part Number | Operating Force (gf) | Operating Life (operations) |
|-----------------------|----------------------|-----------------------------|
| PTS530 GN055 SMTR LFS | 100 ± 30 | 1,000,000 |
| PTS530 GM055 SMTR LFS | 160 ± 30 | 1,000,000 |
| PTS530 GH055 SMTR LFS | 200 ± 30 | 200,000 |
| PTS530 GK055 SMTR LFS | 260 ± 30 | 200,000 |
| PTS530 GG065 SMTR LFS | 400 ± 70 | 300,000 |
| PTS530 GS065 SMTR LFS | 600 - 50/+100 | 150,000 |

Packaging

Switches in reels of 7,000 pieces.
 Dimensions of reels according to EIA 481B
 External diameter 330 mm

Electrical

MAXIMUM VOLTAGE: 12 VDC
 MAXIMUM CURRENT DC: 50 mA
 DIELECTRIC STRENGTH: 250 VA C (1mn)
 CONTACT RESISTANCE: ≤ 100 mΩ
 INSULATION RESISTANCE: ≥ 100 MΩ
 BOUNCE TIME: ≤ 10 ms

Environmental

OPERATING TEMPERATURE: -40°C to 85°C

Process

SOLDERING: This component is suited to the following methods:
 Infrared Reflow Soldering in accordance with IEC61760-1

NOTE: Specifications listed above are for switches with standard options.
 For information on specific and custom switches, consult Customer Service Center.

How To Order

Our easy build-a-switch concept allows you to mix and match options to create the switch you need. To order, select desired option from each category and place it in the appropriate box.

For any part number different from those listed above, please consult your local representative.

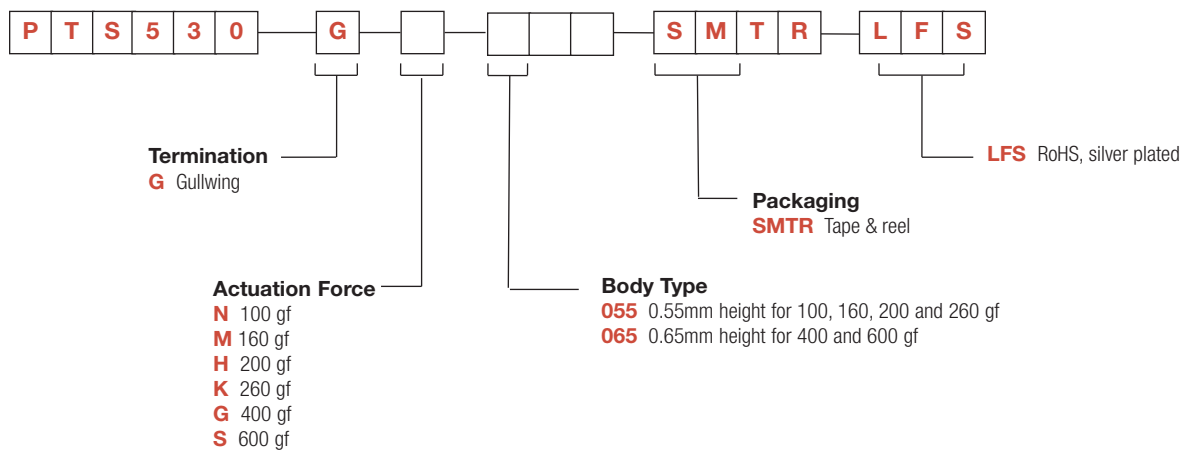

PTS 530 Series Ultra Low Profile SMT Top Actuated

TERMINATION

G GULLWING

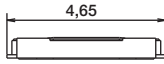

BODY TYPE / ACTUATION FORCE

Tactile Switches

055 0,55 MM HEIGHT

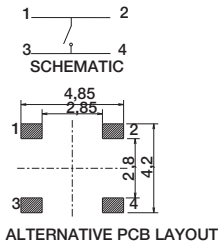
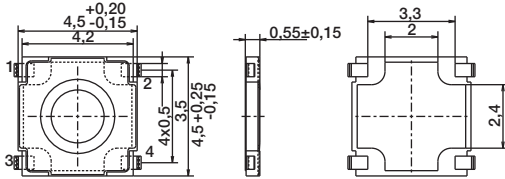

Actuation force identification lines:

| | |
|-----------|----------|
| N: 100 gf | |
| M: 160 gf | No Lines |
| H: 200 gf | |
| K: 260 gf | |

065 0,65 MM HEIGHT

| PART NUMBER | HEIGHT |
|-------------------------|-----------------------|
| PTS 530 GS 065 SMTR LFS | +0.1 -0.05 0.72 |
| PTS 530 GG 065 SMTR LFS | 0.68 |

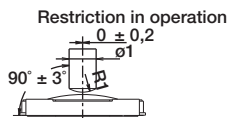
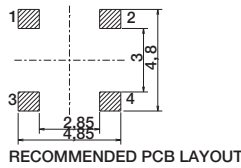
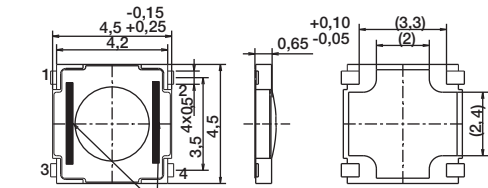
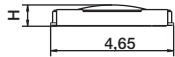

Force symbol lines for 600 gf
No symbol line for 400 gf

| | |
|-----------|----------|
| G: 400 gf | No Lines |
| S: 600 gf | |

TAPE & REEL

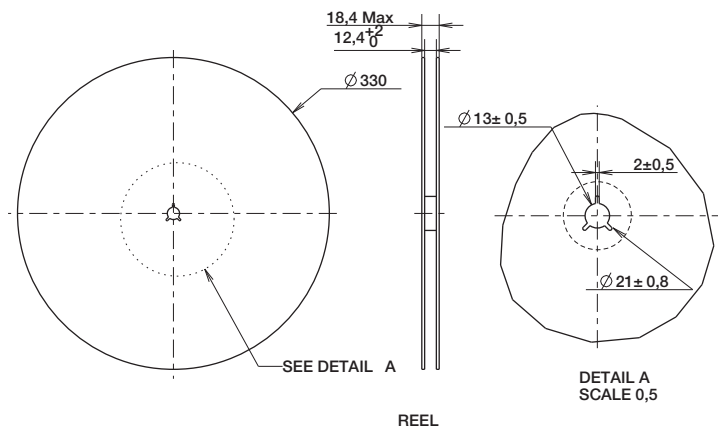
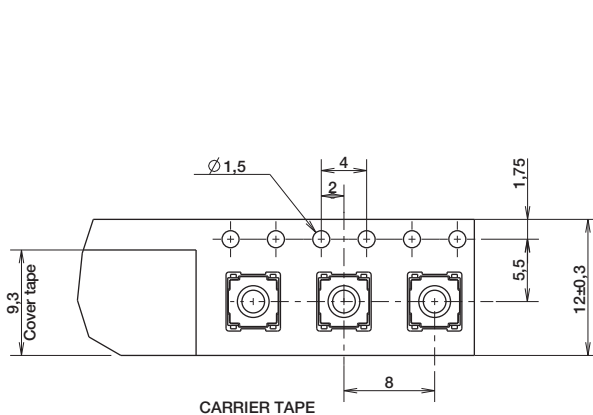

Dimensions are shown: mm
Specifications and dimensions subject to change

PTS 540 Series Ultra Low Profile SMT Top Actuated

Features/Benefits

- 3.7 x 3.7 mm footprint
- 0.35 mm thickness
- High number of cycles

Typical Applications

- MP3 accessories
- Bluetooth headset
- Remote controls



B

Tactile Switches

Specifications

FUNCTION: momentary action
CONTACT ARRANGEMENT: 1 make contact = SPST N.O.
TERMINALS: J type for SMT
TRAVEL: 0.15 mm ± 0.1 mm

Mechanical

| Part Number | Operating Force (gf) | Operating Life (operations) |
|-----------------------|----------------------|-----------------------------|
| PTS540 JM035 SMTR LFS | 160 ± 50 | 500,000 |
| PTS540 JK035 SMTR LFS | 230 ± 50 | 300,000 |

Packaging

Switches in reels of 10,000 pieces.
Dimensions of reels according to EIA 481B
External diameter 330 mm

Electrical

MAXIMUM VOLTAGE: 12 VDC
MAXIMUM CURRENT DC: 50 mA
DIELECTRIC STRENGTH: 250 VA C (1mn)
CONTACT RESISTANCE: ≤ 100 mΩ
INSULATION RESISTANCE: ≥ 100 MΩ
BOUNCE TIME: ≤ 10 ms

Environmental

OPERATING TEMPERATURE: -30°C to 85°C

Process

SOLDERING: This component is suited to the following methods:
Infrared Reflow Soldering in accordance with IEC61760-1

NOTE: Specifications listed above are for switches with standard options.
For information on specific and custom switches, consult Customer Service Center.

How To Order

Our easy build-a-switch concept allows you to mix and match options to create the switch you need. To order, select desired option from each category and place it in the appropriate box.

For any part number different from those listed above, please consult your local representative.

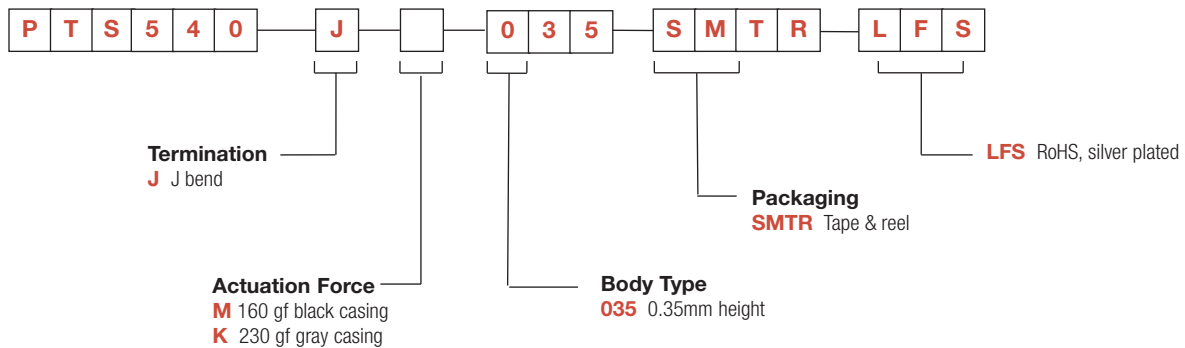

PTS 540 Series Ultra Low Profile SMT Top Actuated

PTS 540

Tactile Switches

B

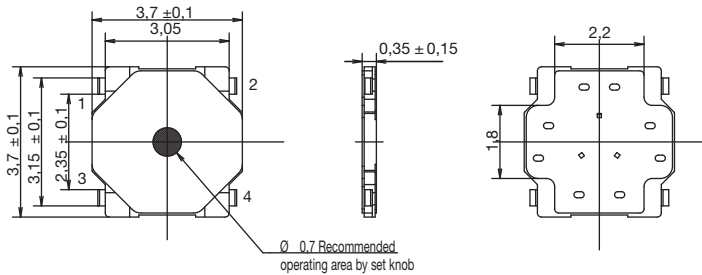

RECOMMENDED PCB

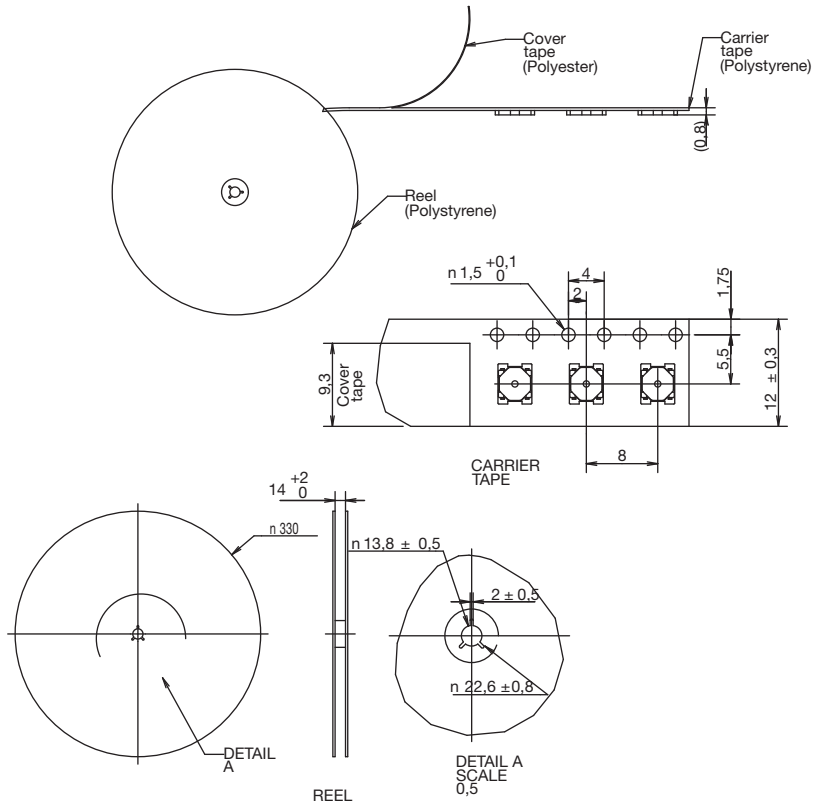
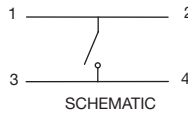
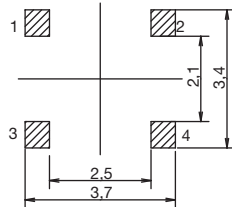

PTS 810 Series Microminiature SMT Top Actuated

Features/Benefits

- 4.2 x 3.2 mm footprint
- 2.5 mm thickness
- High number of cycles
- Color coded actuators

Typical Applications

- Control panels
- Nomad devices
- Remote controls
- Keyless entry system



Specifications

FUNCTION: momentary action
 CONTACT ARRANGEMENT: 1 make contact = SPST N.O.
 TERMINALS: J type for SMT
 TRAVEL: 160 & 260 gf: 0.15mm ± 0.1mm
 400 & 600 gf: 0.20mm ± 0.1mm

| | Operating Force (gf) | Operating Life (operations) |
|-------------------------|----------------------|-----------------------------|
| PTS810 SJM 250 SMTR LFS | 160 ± 50 | 150,000 |
| PTS810 SJK 250 SMTR LFS | 260 ± 70 | 50,000 |
| PTS810 SJG 250 SMTR LFS | 400 ± 100 | 100,000 |
| PTS810 SJS 250 SMTR LFS | 600 ± 150 | 150,000 |

Packaging

Switches in reels of 2,900 pieces.
 Dimensions of reels according to EIA 481B
 External diameter 330 mm

Electrical

MAXIMUM VOLTAGE: 16 VDC
 MAXIMUM CURRENT DC: 50 mA
 DIELECTRIC STRENGTH: 250 VA C (1mn)
 CONTACT RESISTANCE: ≤ 500 mΩ
 INSULATION RESISTANCE: ≥ 100 MΩ
 BOUNCE TIME: ≤ 10 ms

Environmental

OPERATING TEMPERATURE: -40°C to 85°C

Process

SOLDERING: This component is suited to the following methods:
 Infrared Reflow Soldering in accordance with IEC61760-1

NOTE: Specifications listed above are for switches with standard options.
 For information on specific and custom switches, consult Customer Service Center.

How To Order

Our easy build-a-switch concept allows you to mix and match options to create the switch you need. To order, select desired option from each category and place it in the appropriate box.

For any part number different from those listed above, please consult your local representative.

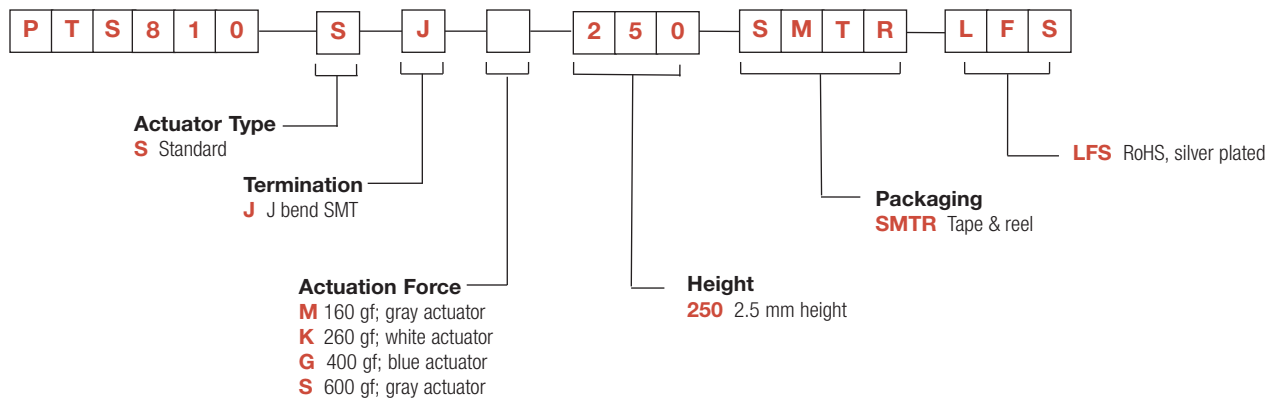

PTS 810 Series Microminiature SMT Top Actuated

PTS810

Tactile Switches

B

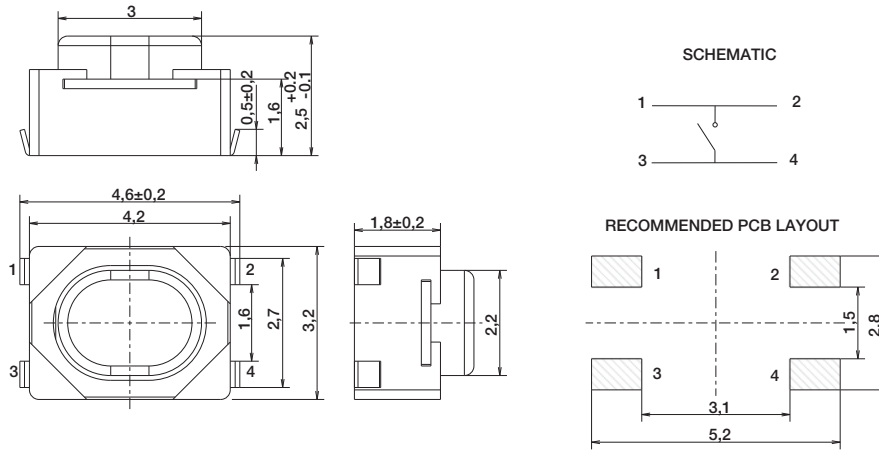

TAPE & REEL

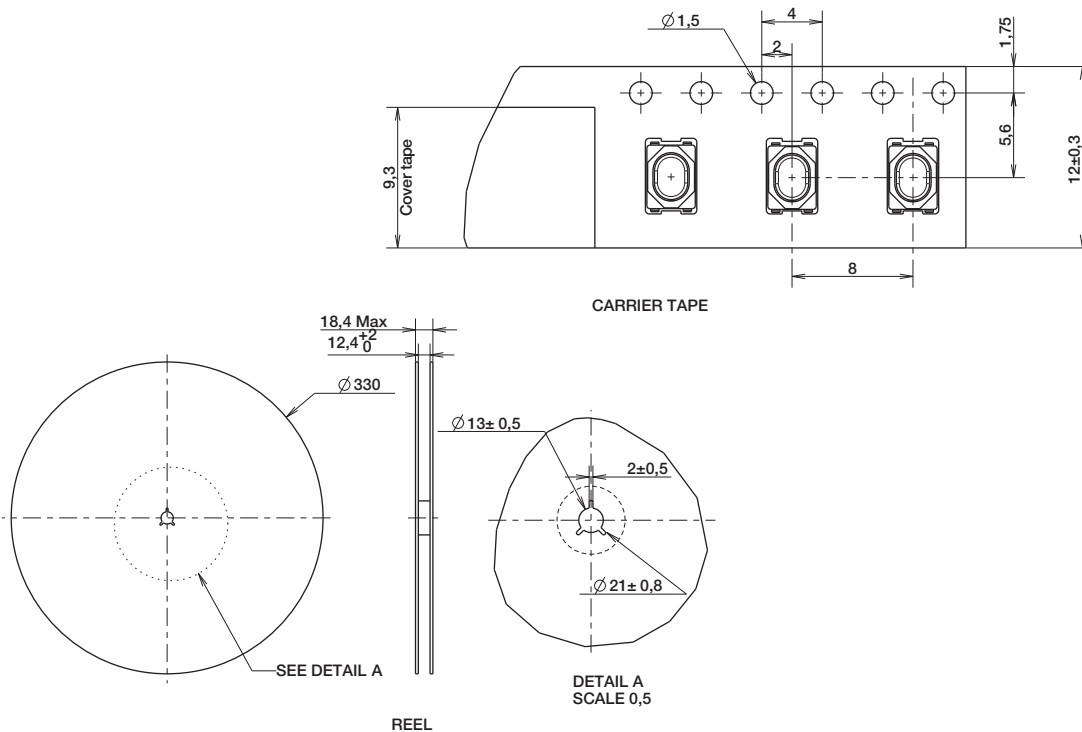

Dimensions are shown: mm
Specifications and dimensions subject to change

PTS 820 Series Microminiature SMT Top Actuated

Features/Benefits

- 3.9 x 2.9 mm footprint
- Three different heights
- High number of cycles
- Reduced footprint

Typical Applications

- Control panels
- Nomad devices
- Remote controls
- Keyless entry system



Specifications

FUNCTION: momentary action
 CONTACT ARRANGEMENT: 1 make contact = SPST N.O.
 TERMINALS: J type for SMT
 TRAVEL: 0.2mm + 0.1mm / -0.05 mm

| | Operating Force (gf) | Life Cycles | Height mm | Pegs |
|-----------------------|----------------------|-------------|-----------|------|
| PTS820 J25M SMTR LFS | 160 ± 50 | 200,000 | 2.5 | No |
| PTS820 J25K SMTR LFS | 250 ± 50 | 100,000 | 2.5 | No |
| PTS820 J25MP SMTR LFS | 160 ± 50 | 200,000 | 2.5 | Yes |
| PTS820 J25KP SMTR LFS | 250 ± 50 | 100,000 | 2.5 | Yes |
| PTS820 J20M SMTR LFS | 160 ± 50 | 200,000 | 2.0 | No |
| PTS820 J20K SMTR LFS | 250 ± 50 | 100,000 | 2.0 | No |
| PTS820 J20MP SMTR LFS | 160 ± 50 | 200,000 | 2.0 | Yes |
| PTS820 J20KP SMTR LFS | 250 ± 50 | 100,000 | 2.0 | Yes |
| PTS820 J15M SMTR LFS | 160 ± 50 | 200,000 | 1.5 | No |
| PTS820 J15K SMTR LFS | 250 ± 50 | 100,000 | 1.5 | No |
| PTS820 J15MP SMTR LFS | 160 ± 50 | 200,000 | 1.5 | Yes |
| PTS820 J15KP SMTR LFS | 250 ± 50 | 100,000 | 1.5 | Yes |

Packaging

Switches in reels of 2,500 pieces for 1.5 and 2.0 mm height
 Switches in reels of 2,300 pieces for 2.5 mm height
 Dimensions of reels according to EIA 481B
 External diameter 330 mm

Electrical

MAXIMUM VOLTAGE: 12 VDC
 MAXIMUM CURRENT DC: 50 mA
 DIELECTRIC STRENGTH: 100 VA C (1mn)
 CONTACT RESISTANCE: ≤ 100 mΩ
 INSULATION RESISTANCE: ≥ 100 MΩ
 BOUNCE TIME: ≤ 10 ms

Environmental

OPERATING TEMPERATURE: -40°C to 85°C

Process

SOLDERING: This component is suited to the following methods:
 Infrared Reflow Soldering in accordance with IEC61760-1

NOTE: Specifications listed above are for switches with standard options.
 For information on specific and custom switches, consult Customer Service Center.

How To Order

Our easy build-a-switch concept allows you to mix and match options to create the switch you need. To order, select desired option from each category and place it in the appropriate box.

For any part number different from those listed above, please consult your local representative.

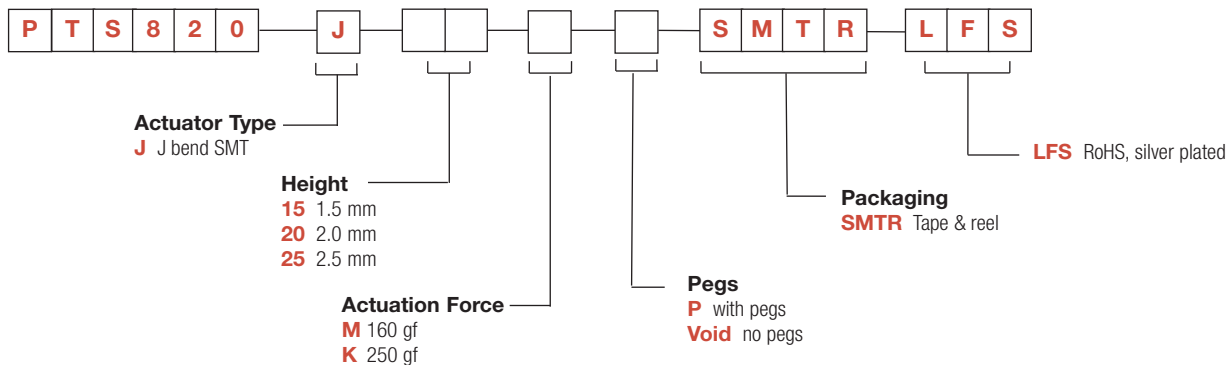

PTS 820 Series Microminiature SMT Top Actuated

2.5 & 2.0 mm height (H) - version shown here with pegs

Tactile Switches

B

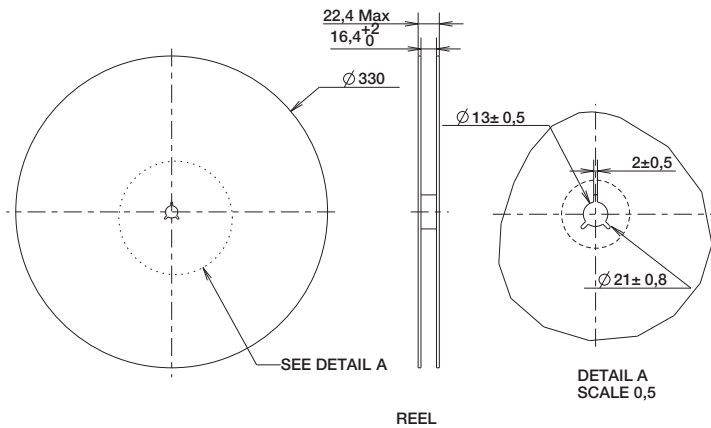
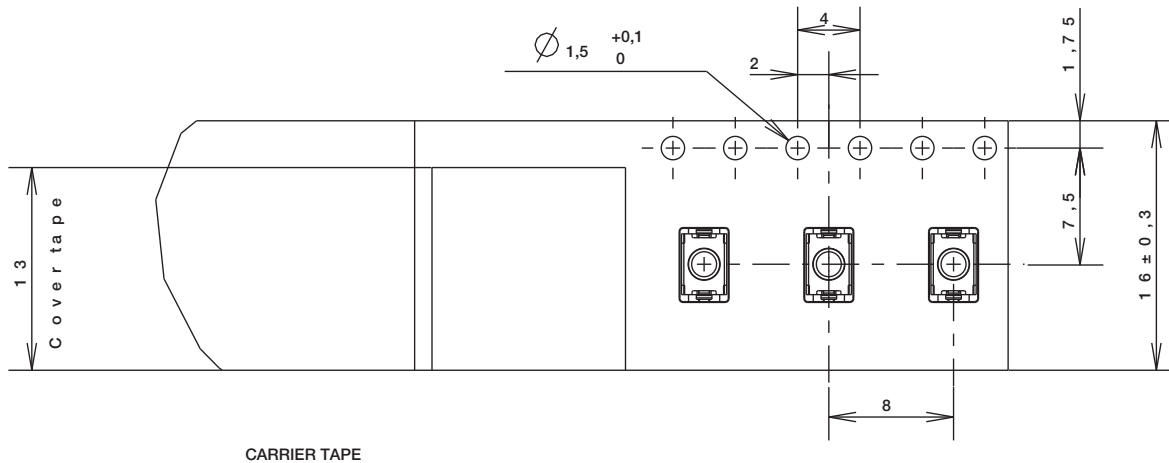
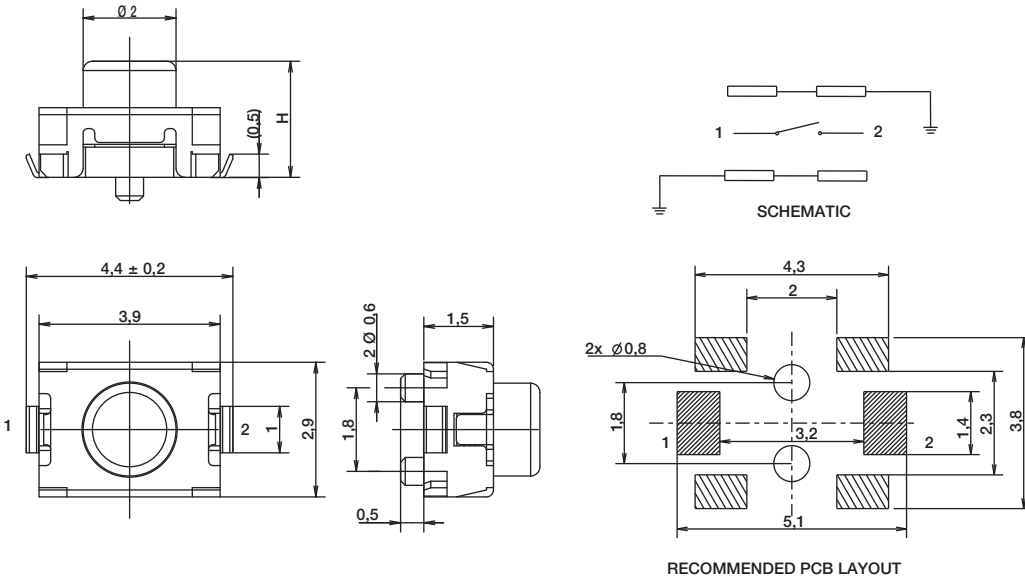

Dimensions are shown: mm
Specifications and dimensions subject to change

PTS 820 Series Microminiature SMT Top Actuated

1.5 mm height (H) - version shown here with pegs

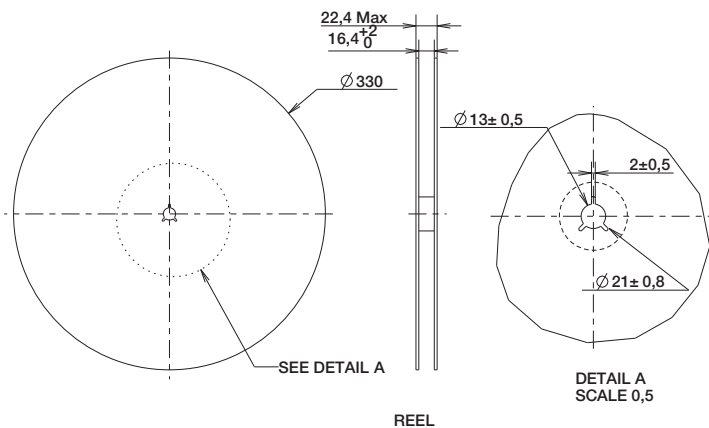
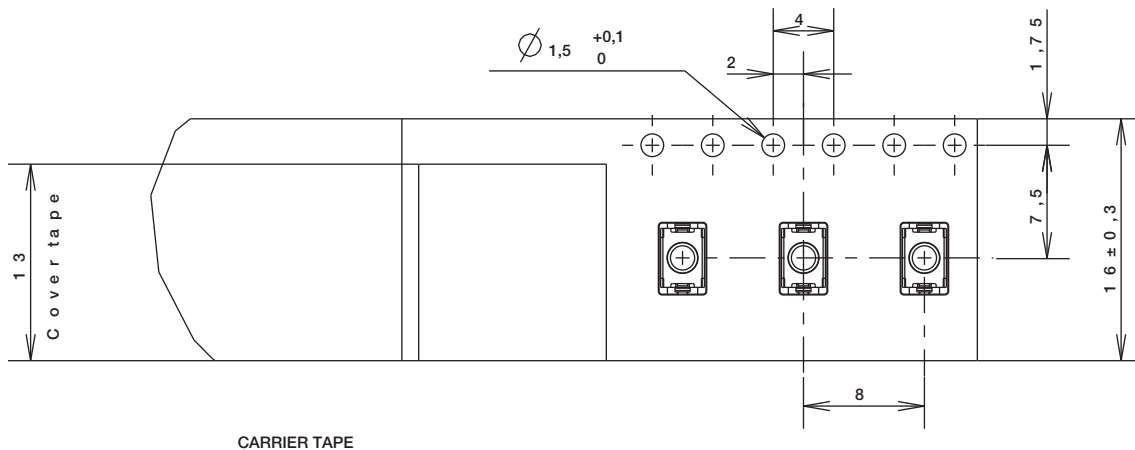
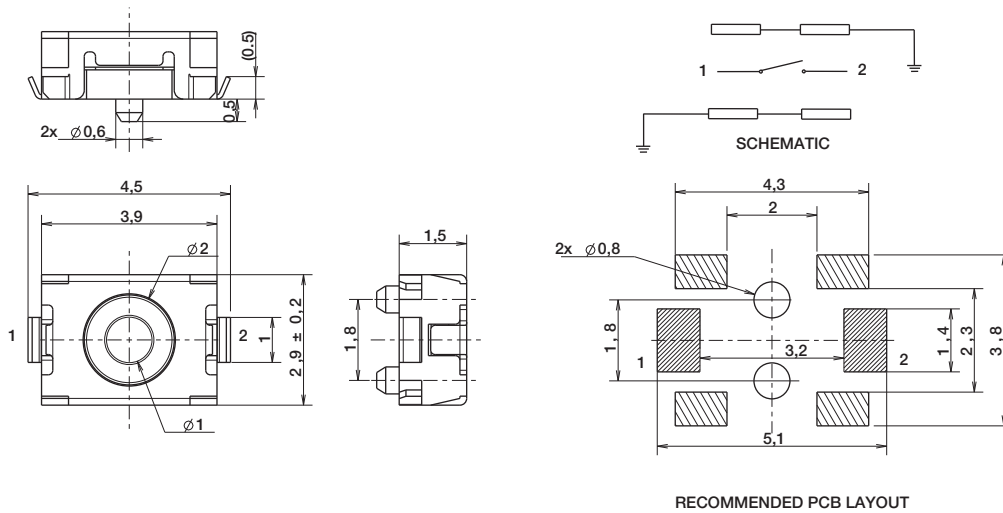

B
Tactile Switches



Dimensions are shown: mm
Specifications and dimensions subject to change

PTS 830 Series Microminiature SMT Top Actuated



Features/Benefits

- 3.5 x 2.6 mm footprint
- High number of cycles
- Optional ground pin

Typical Applications

- Wearable electronics
- Nomad devices
- Remote controls
- Keyless entry system

B

Tactile Switches

Specifications

FUNCTION: momentary action
 CONTACT ARRANGEMENT: 1 make contact = SPST N.O.
 TERMINALS: G type for SMT
 TRAVEL: 0.15 mm + 0.1 mm

| | Operating Force (gf) | Life Cycles | Ground Pin |
|------------------------|----------------------|-------------|------------|
| PTS830 GM140 SMTR LFS | 160 ± 50 | 500,000 | No |
| PTS830 GG140 SMTR LFS | 450 ± 80 | 200,000 | No |
| PTS830 GM140G SMTR LFS | 160 ± 50 | 500,000 | Yes |
| PTS830 GG140G SMTR LFS | 450 ± 80 | 200,000 | Yes |

Packaging

Switches in reels of 9,500 pieces
 Dimensions of reels according to EIA 481B
 External diameter 330 mm

Electrical

MAXIMUM VOLTAGE: 12 VDC
 MAXIMUM CURRENT DC: 50 mA
 DIELECTRIC STRENGTH: 100 VA C (1mm)
 CONTACT RESISTANCE: ≤ 100 mΩ
 INSULATION RESISTANCE: ≥ 100 MΩ
 BOUNCE TIME: ≤ 10 ms

Environmental

OPERATING TEMPERATURE: -40°C to 85°C

Process

SOLDERING: This component is suited to the following methods:
 Infrared Reflow Soldering in accordance with IEC61760-1

NOTE: Specifications listed above are for switches with standard options.
 For information on specific and custom switches, consult Customer Service Center.

How To Order

Our easy build-a-switch concept allows you to mix and match options to create the switch you need. To order, select desired option from each category and place it in the appropriate box.

For any part number different from those listed above, please consult your local representative.

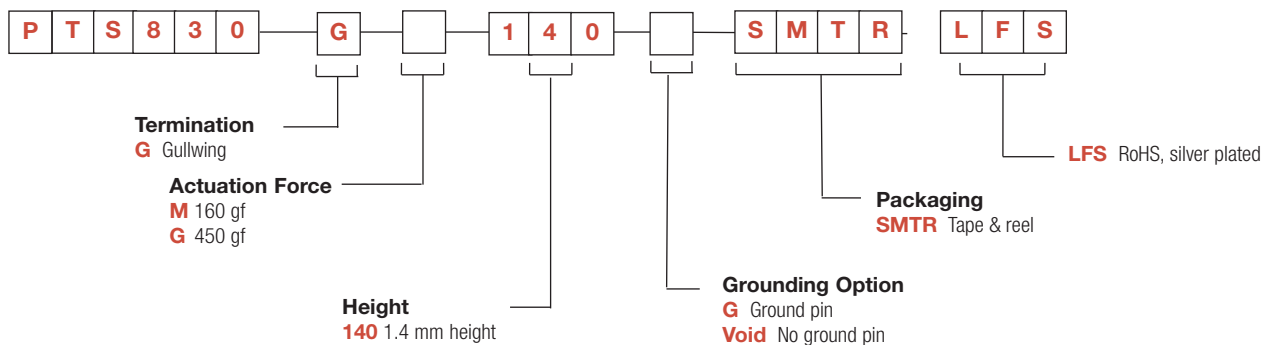

Dimensions are shown: mm
 Specifications and dimensions subject to change

PTS 830 Series Microminiature SMT Top Actuated

PTS830 GX 140 SMTR LFS

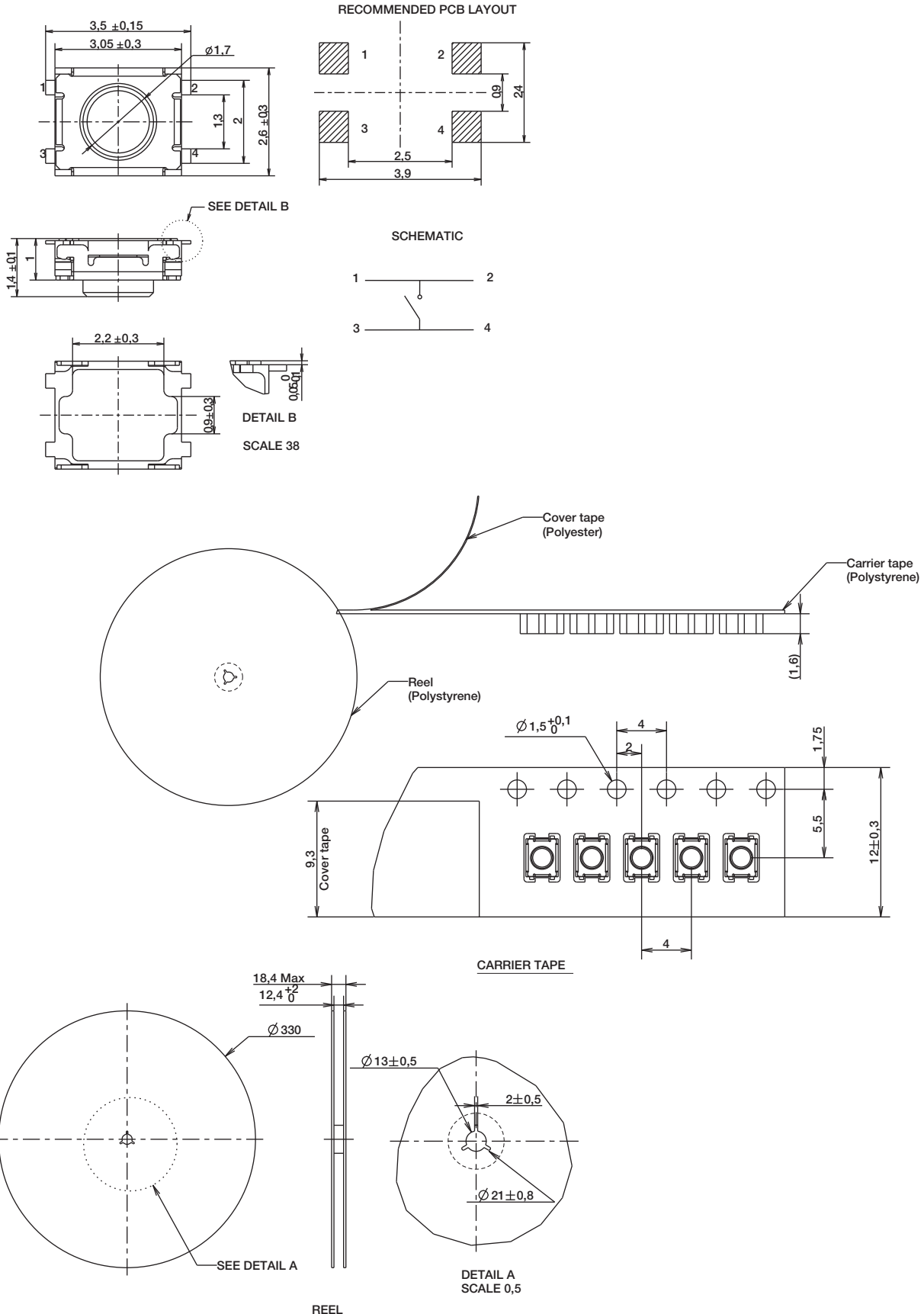

B
Tactile Switches



Dimensions are shown: mm
Specifications and dimensions subject to change

PTS 830 Series Microminiature SMT Top Actuated

PTS830 GX 140 G SMTR LFS

Tactile Switches

B

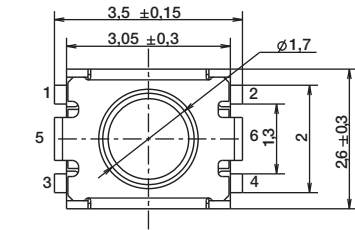

RECOMMENDED PCB LAYOUT

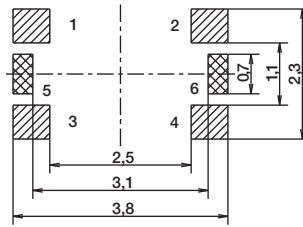

SCHEMATIC

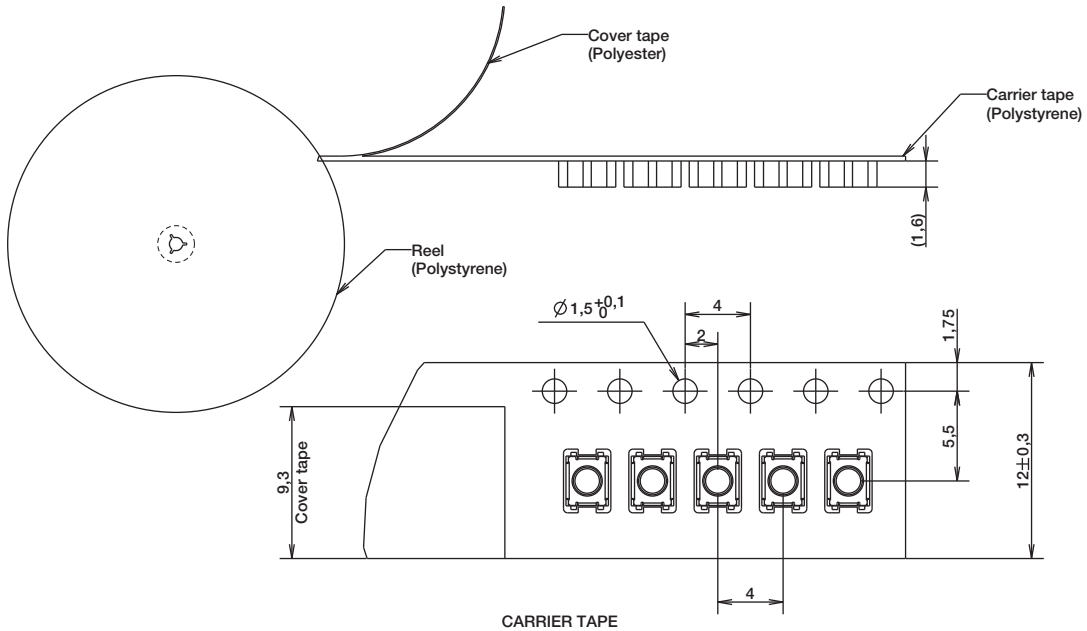
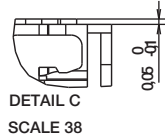
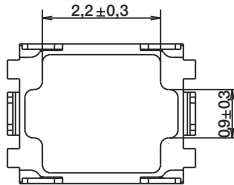
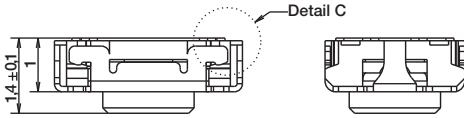
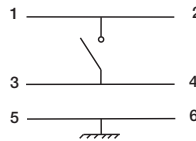

CARRIER TAPE

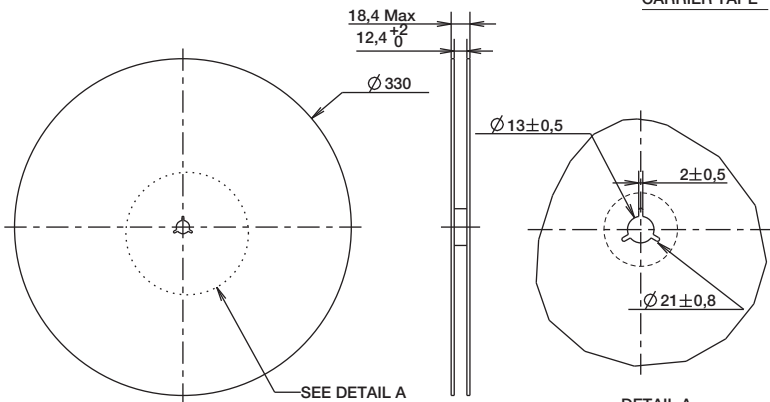

DETAIL A
SCALE 0,5

REEL



Dimensions are shown: mm
Specifications and dimensions subject to change



B

Tactile Switches

PTS 840 Series Microminiature SMT Side Actuated



Features/Benefits

- **3.5 x 3.55 mm footprint**
- **Front PIP leads option for strong shear resistance**
- **ESD pin option**
- **Reduced footprint**

Typical Applications

- **Nomad devices**
- **Remote controls**
- **Personal health diagnostics**
- **Consumer electronics**

Specifications

FUNCTION: momentary action
 CONTACT ARRANGEMENT: 1 make contact = SPST N.O.
 TERMINALS: G and front PIP types for SMT
 TRAVEL: 0.2mm + 0.2mm / -0.1 mm
 LIFE: 100,000 cycles

| Type | Operating Force (gf) | SMT Leads | Pegs |
|---------------------------|----------------------|-----------|------|
| Without ground pin | | | |
| PTS840 GM SMTR LFS | 160 -40/+70 | G leads | No |
| PTS840 GK SMTR LFS | 220 -70/+80 | G leads | No |
| PTS840 PM SMTR LFS | 160 -40/+70 | P leads | No |
| PTS840 PK SMTR LFS | 220 -70/+80 | P leads | No |
| PTS840 GMP SMTR LFS | 160 -40/+70 | G leads | Yes |
| PTS840 GKP SMTR LFS | 220 -70/+80 | G leads | Yes |
| With ground pin | | | |
| PTS840 ESDGM SMTR LFS | 160 -40/+70 | G leads | No |
| PTS840 ESDGK SMTR LFS | 220 -70/+80 | G leads | No |
| PTS840 ESDPM SMTR LFS | 160 -40/+70 | P leads | No |
| PTS840 ESDPK SMTR LFS | 220 -70/+80 | P leads | No |
| PTS840 ESDGMP SMTR LFS | 160 -40/+70 | G leads | Yes |
| PTS840 ESDGKP SMTR LFS | 220 -70/+80 | G leads | Yes |

Electrical

MAXIMUM VOLTAGE: 12 VDC
 MAXIMUM CURRENT DC: 50 mA
 DIELECTRIC STRENGTH: 250 VA C (1mm)
 CONTACT RESISTANCE: ≤ 500 mΩ
 INSULATION RESISTANCE: ≥ 100 MΩ
 BOUNCE TIME: ≤ 10 ms

Environmental

OPERATING TEMPERATURE: -40°C to 85°C

Process

SOLDERING: This component is suited to the following methods:
 Infrared Reflow Soldering in accordance with IEC61760-1

Packaging

In reels of 3,500 pieces
 Dimensions of reels according to EIA 481B
 External diameter 330 mm

NOTE: Specifications listed above are for switches with standard options.
 For information on specific and custom switches, consult Customer Service Center.

How To Order

Our easy build-a-switch concept allows you to mix and match options to create the switch you need. To order, select desired option from each category and place it in the appropriate box.

For any part number different from those listed above, please consult your local representative.

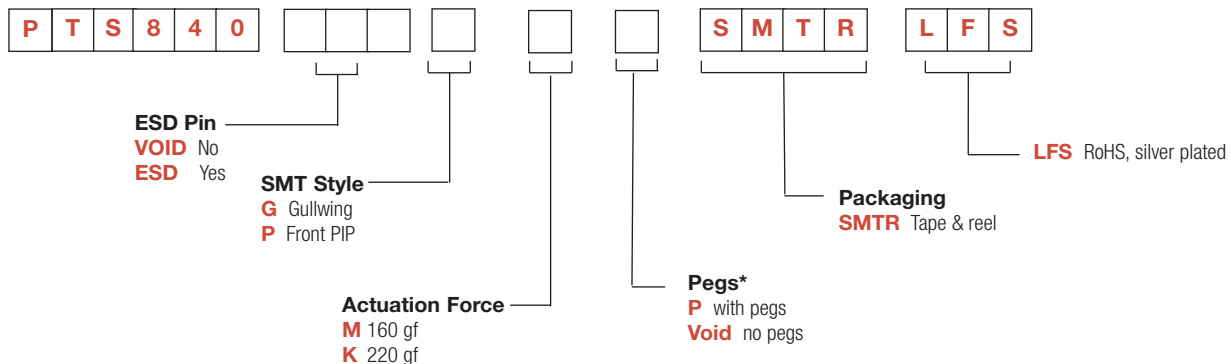

Design Recommendations

- "P" leads are recommended for applications where shear resistance is of importance
- When a precise alignment between application button and the switch is requested, version with pegs are the right choice to limit the possible floating of the switch during solderability.

PTS 840 Series Microminiature SMT Side Actuated

Standard G SMT Leads with ESD and Peg options

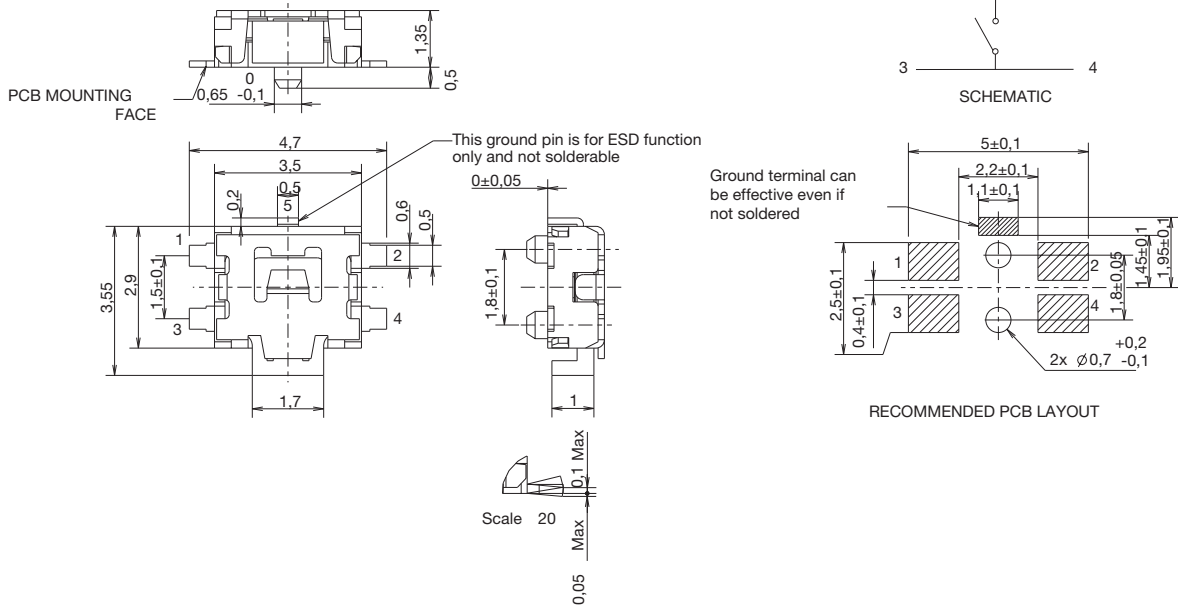

P SMT Leads with ESD option

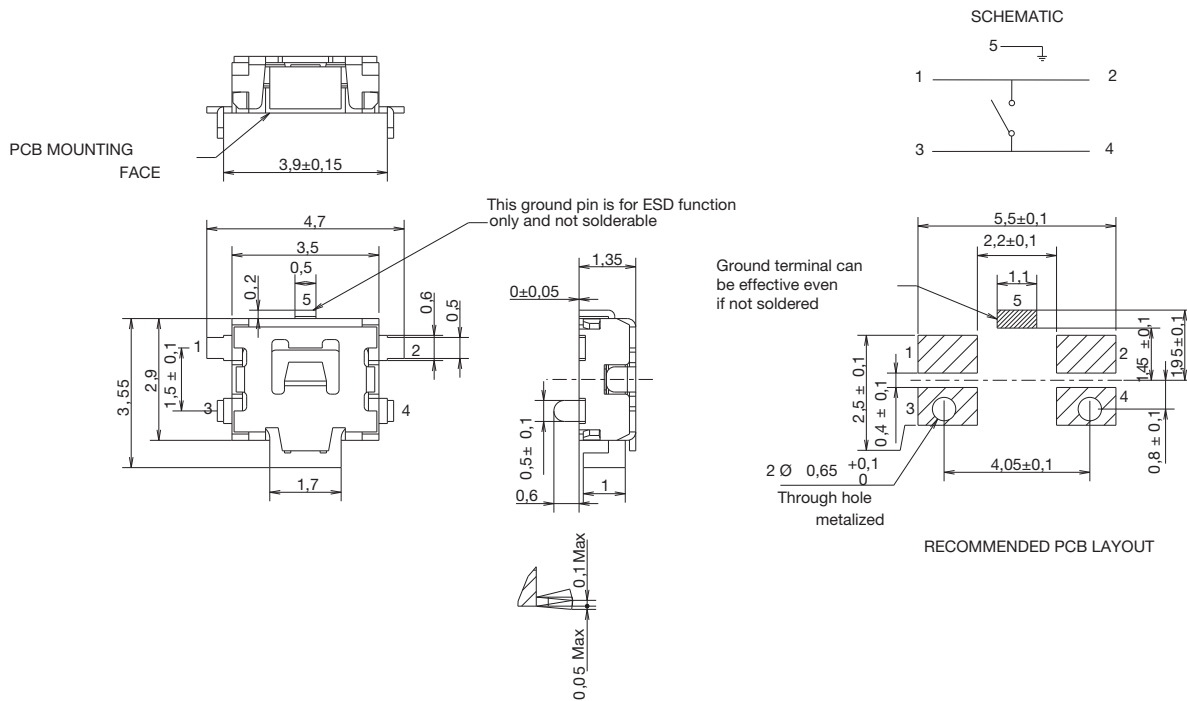

B

Tactile Switches

PTS 840 Series Microminiature SMT Side Actuated

TAPE & REEL

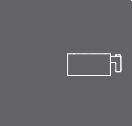

B

Tactile Switches

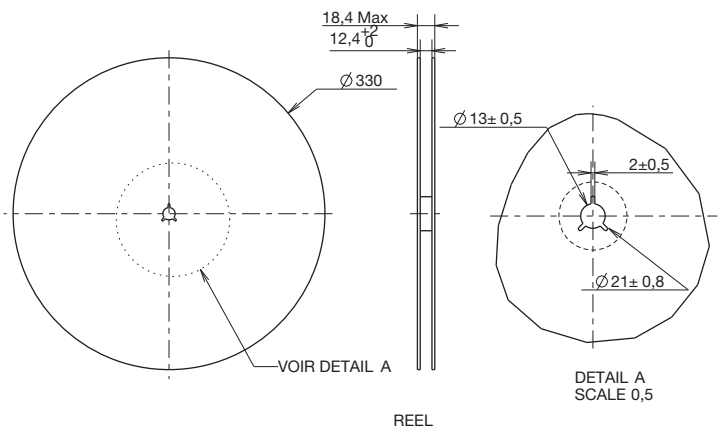
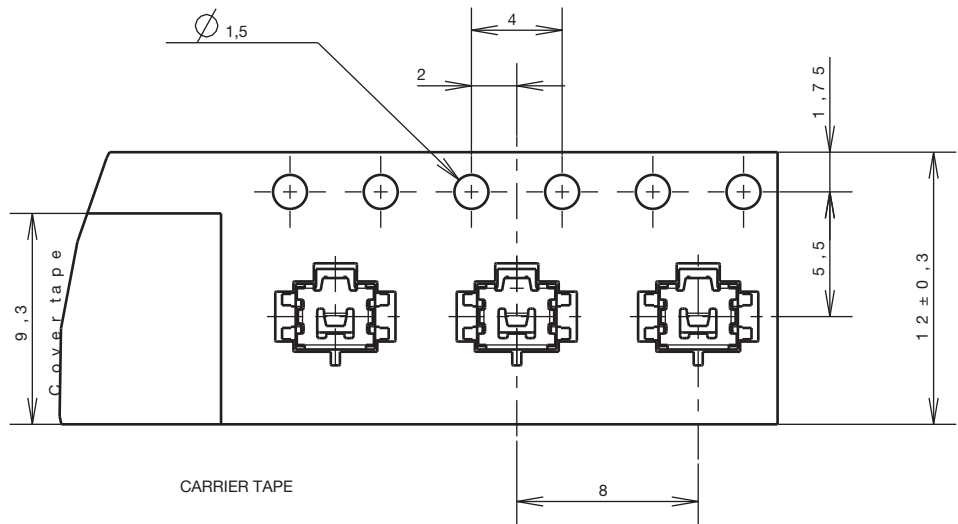

KSR Series Subminiature Tact Switch for SMT

Features/Benefits

- 4 actuation forces
- G terminations
- N.O. and N.C.
- Detect type available
- Rubber actuator
- IP50 sealed
- RoHS compliant and compatible

Typical Applications

- Automotive
- Medical equipment
- Industrial electronics
- Smart meters



B

Tactile Switches

Specification

FUNCTION: momentary action
CONTACT ARRANGEMENT: Normally Open
TERMINALS: Gullwing type for SMT

Mechanical

| Type | Operating force Newtons (grams) | Operating life (operations) | Travel (mm) |
|---------------------------|------------------------------------|--------------------------------|----------------|
| KSR211G LFS / KSR213G LFG | 1,5 < 1,85 (185) < 2,2 | 100,000 | 0,25 ± 0,15 |
| KSR221G LFS / KSR223G LFG | 1,9 < 2,25 (225) < 2,6 | 100,000 | 0,3 ± 0,15 |
| KSR231G LFS /KSR233G LFG | 2,25 < 3,00 (300) < 3,75 | 100,000 | 0,35 ± 0,15 |
| KSR251G LFS / KSR253G LFG | 3,4 < 4,50 (450) < 5,6 | 100,000 | 0,5 ± 0,15 |
| KSR221G NC LFS | 1,5 < 2,25 (225) < 3 | 30,000 | 0,3 ± 0,15 |
| KSR223G NC LFG | 1,5 < 2 (200) < 2,5 | 30,000 | 0,3 ± 0,15 |

Overload: 20 Newtons
Detect switch versions are available. Please see Detect chapter
KSR2D/M series.

Packaging

Switches are delivered on continuous tape, in reels of 2,500 pieces.

Electrical

| | Silver | Gold |
|---------------------|--------|--------|
| MAXIMUM POWER: | 1 VA | 0.2 VA |
| MAXIMUM VOLTAGE: | 32 VDC | 32 VDC |
| MINIMUM VOLTAGE: | 20 mV | 20 mV |
| MAXIMUM CURRENT DC: | 50 mA | 10 mA |
| MINIMUM CURRENT DC: | 1 mA | 1 mA |

CONTACT RESISTANCE: ≤ 100 mΩ
INSULATION RESISTANCE: (100 V): 1G Ω (between terminals)
BOUNCE TIME: 1 ms max.

Environmental

| | Silver | Gold |
|------------------------|---------------|----------------|
| OPERATING TEMPERATURE: | -40°C to 85°C | -40°C to 125°C |
| STORAGE TEMPERATURE: | -55°C to 85°C | -55°C to 125°C |

Process

SOLDERING: Compatible with lead free reflow soldering process.

NOTE: Specifications listed above are for switches with standard options.
For information on specific and custom switches, consult Customer Service Center.

How To Order

Our easy build-a-switch concept allows you to mix and match options to create the switch you need. To order, select desired option from each category and place it in the appropriate box.

However, please note that all the combinations of these options are not feasible.

For any part number different from those listed above, please consult your local representative.

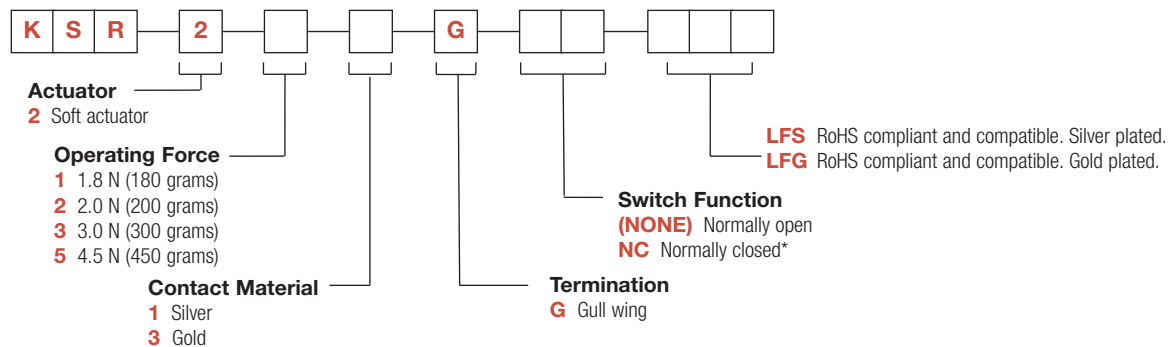

*Available on KSR223G only.



Dimensions are shown: mm
Specifications and dimensions subject to change

KSR Series Subminiature Tact Switch for SMT

KSR



B

Tactile Switches

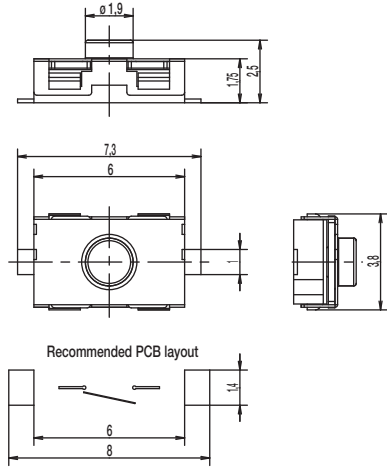

TAPE & REEL

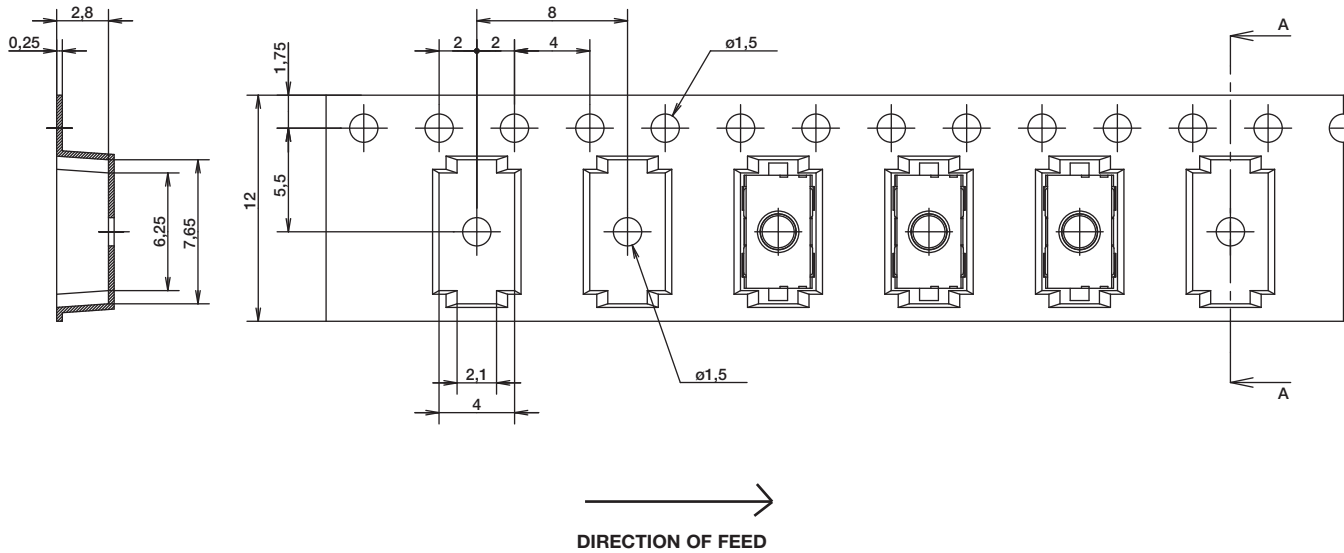

Dimensions are shown: mm
Specifications and dimensions subject to change

KSR Long Life-200,000 cycles-Gold and Silver Series Subminiature Tact Switch for SMT

Features/Benefits

- 4 actuation forces
- G terminations
- N.O.
- Detect type available
- Rubber actuator
- IP50 sealed
- RoHS compliant and compatible

Typical Applications

- Automotive
- Medical equipment
- Industrial electronics



B

Tactile Switches

Specification

FUNCTION: momentary action
CONTACT ARRANGEMENT: Normally Open
TERMINALS: Gullwing type for SMT

Mechanical

| Type | Operating force(Fa) Newtons (grams) | Operating life (operations) | Travel (mm) |
|------------------------|--|--------------------------------|----------------|
| Silver versions | | | |
| KSR212G LFS | 1,5 < 1,85 (185) < 2,2 | 200,000 | 0,25 ± 0,15 |
| KSR222G LFS | 1,9 < 2,25 (225) < 2,6 | 200,000 | 0,3 ± 0,15 |
| KSR232G LFS | 2,25 < 3,00 (300) < 3,75 | 200,000 | 0,35 ± 0,15 |
| KSR252G LFS | 3,4 < 4,50 (450) < 5,6 | 200,000 | 0,5 ± 0,15 |
| Gold versions | | | |
| KSR214G LFS | 1,5 < 1,85 (185) < 2,2 | 200,000 | 0,25 ± 0,15 |
| KSR224G LFS | 1,9 < 2,25 (225) < 2,6 | 200,000 | 0,3 ± 0,15 |
| KSR234G LFS | 2,25 < 3,00 (300) < 3,75 | 200,000 | 0,35 ± 0,15 |
| KSR254G LFS | 3,4 < 4,50 (450) < 5,6 | 200,000 | 0,5 ± 0,15 |

OVERLOAD: 20 Newtons

Packaging

Switches are delivered on continuous tape, in reels of 2,500 pieces.

Electrical

| | Silver | Gold |
|---------------------|----------|----------|
| MAXIMUM POWER: | 1 VA | 0.2 VA |
| MAXIMUM VOLTAGE: | 32 V dc | 32 V dc |
| MINIMUM VOLTAGE: | 20 m Vdc | 20 m Vdc |
| MAXIMUM CURRENT DC: | 50 mA | 10 mA |
| MINIMUM CURRENT DC: | 1 mA | 1 mA |

CONTACT RESISTANCE: ≤ 100 m Ω
INSULATION RESISTANCE (100 V): 1 G Ω (between terminals)
BOUNCE TIME: 1 ms max

Environmental

| | Silver | Gold |
|------------------------|---------------|----------------|
| OPERATING TEMPERATURE: | -40°C to 85°C | -40°C to 125°C |
| STORAGE TEMPERATURE: | -55°C to 85°C | -55°C to 125°C |

Process

SOLDERING: Compatible with lead free reflow soldering process.

NOTE: Specifications listed above are for switches with standard options.
For information on specific and custom switches, consult Customer Service Center.

How To Order

Our easy build-a-switch concept allows you to mix and match options to create the switch you need. To order, select desired option from each category and place it in the appropriate box.

However, please note that all the combinations of these options are not feasible.

For any part number different from those listed above, please consult your local representative.

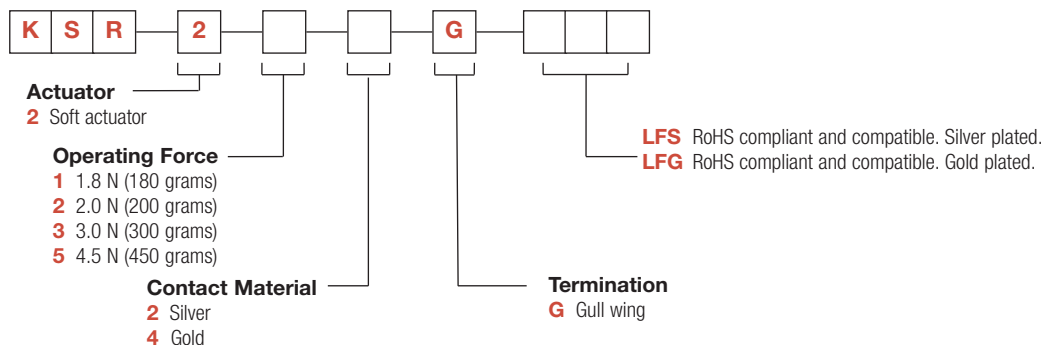

Dimensions are shown: mm
Specifications and dimensions subject to change

KSR Long Life-200,000 cycles-Gold and Silver Series Subminiature Tact Switch for SMT

KSR

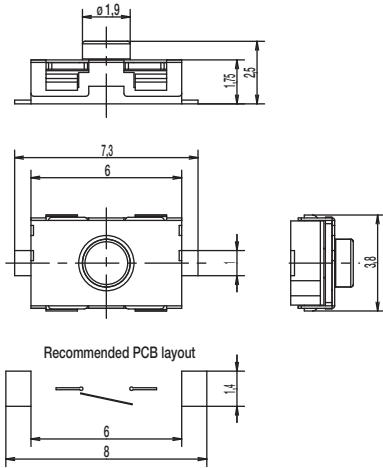

TAPE & REEL

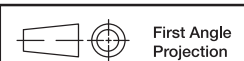
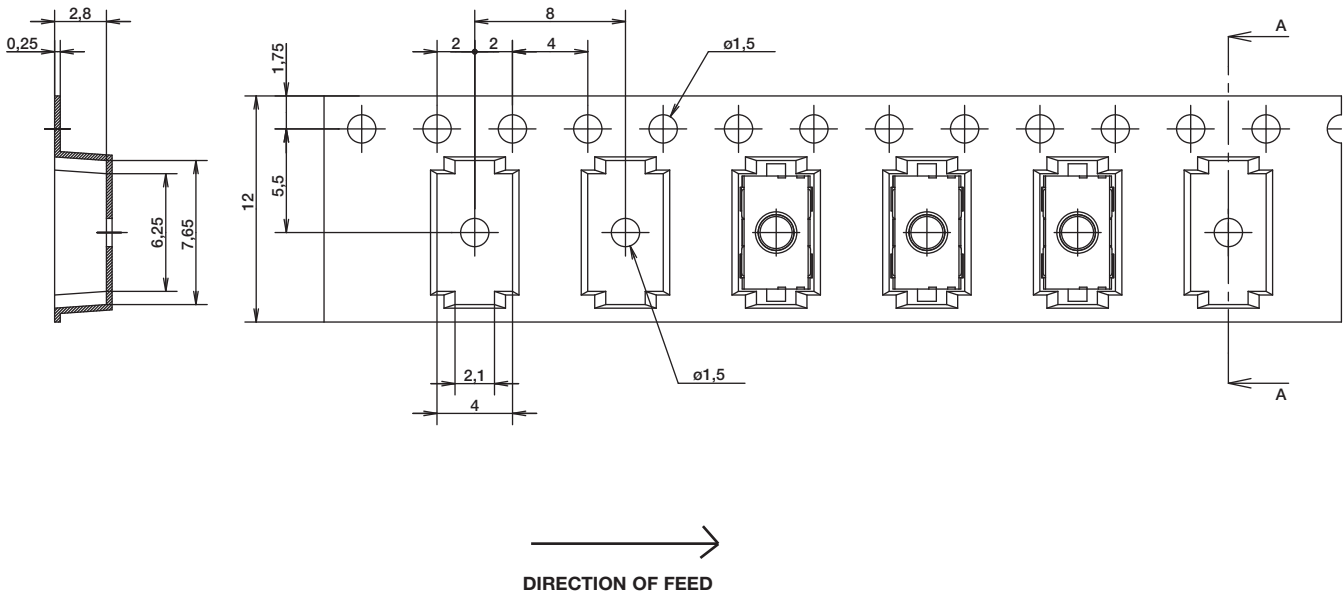

Dimensions are shown: mm
Specifications and dimensions subject to change



KSS Series Subminiature SMT Side Actuated

Features/Benefits

- Low profile of 1.7 mm
- Excellent tactile feel
- High shear force
- Range of actuation forces
- Large flat top
- RoHS compliant and compatible

Typical Applications

- Cellular phone
- Industrial electronics
- Health diagnostic electronics



B

Tactile Switches

Specification

FUNCTION: momentary action
CONTACT ARRANGEMENT: N.O.
TERMINALS: Gullwing
IP40 sealed

Mechanical

OVERLOAD: 20N
TACTILE FEELING: 2 and 4N: 25% min.
2.5N: 30% min.

| Type | Operating force Newtons (grams) | Operating life (operations) | Travel (mm) |
|---------|------------------------------------|--------------------------------|----------------|
| KSS221G | 2.0 (200) ± 0.5 | 100,000 | 0,3 ± 0,15 |
| KSS231G | 2.5 (250) ± 0.5 | 100,000 | 0,3 ± 0,10 |
| KSS241G | 4.0 (400) ± 1.0 | 100,000 | 0,3 ± 0,15 |

NOTE: Specifications listed above are for switches with standard options.
For information on specific and custom switches, consult Customer Service Center.

Electrical

| | Silver | Gold |
|--|--------|--------|
| MAXIMUM POWER: | 1 VA | 0.2 VA |
| MAXIMUM VOLTAGE: | 32 VDC | 32 VDC |
| MAXIMUM CURRENT: | 50 mA | 10 mA |
| MINIMUM CURRENT: | 1 mA | 1 mA |
| DIELECTRIC STRENGTH: ≥ 250 VDC | | |
| CONTACT RESISTANCE: < 100 mΩ | | |
| INSULATION RESISTANCE (100 VDC): ≥ 10 ⁹ Ω | | |
| BOUNCE TIME: < 3 ms | | |

Environmental

| | Silver | Gold |
|------------------------|---------------|----------------|
| OPERATING TEMPERATURE: | -40°C to 85°C | -40°C to 125°C |
| STORAGE TEMPERATURE: | -55°C to 85°C | -55°C to 125°C |

Process

Infrared reflow soldering in accordance with IEC 61760-1

Packaging

Tape and reels in reels of 3,000 pieces.
External diameter 330mm ± 2mm.

How To Order

Our easy build-a-switch concept allows you to mix and match options to create the switch you need. To order, select desired option from each category and place it in the appropriate box.

However, please note that all the combinations of these options are not feasible.

For any part number different from those listed above, please consult your local representative.

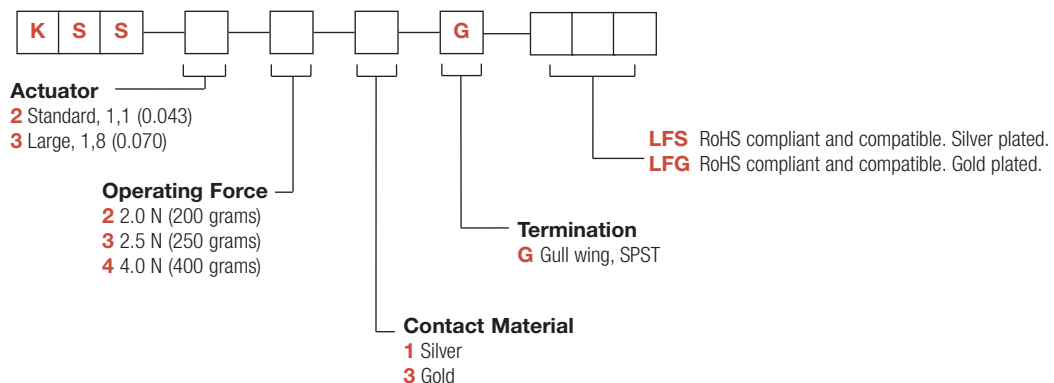

KSS Series Subminiature SMT Side Actuated

KSS

B

Tactile Switches

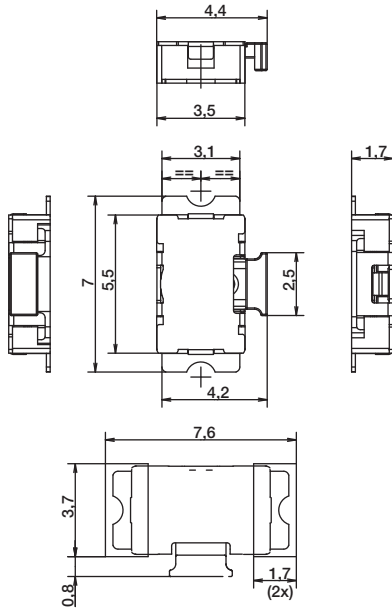

ACTUATOR

2 STANDARD, 1,1 (0.043)

3 LARGE, 1,8 (0.070)

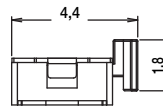
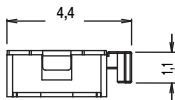

TAPE & REEL

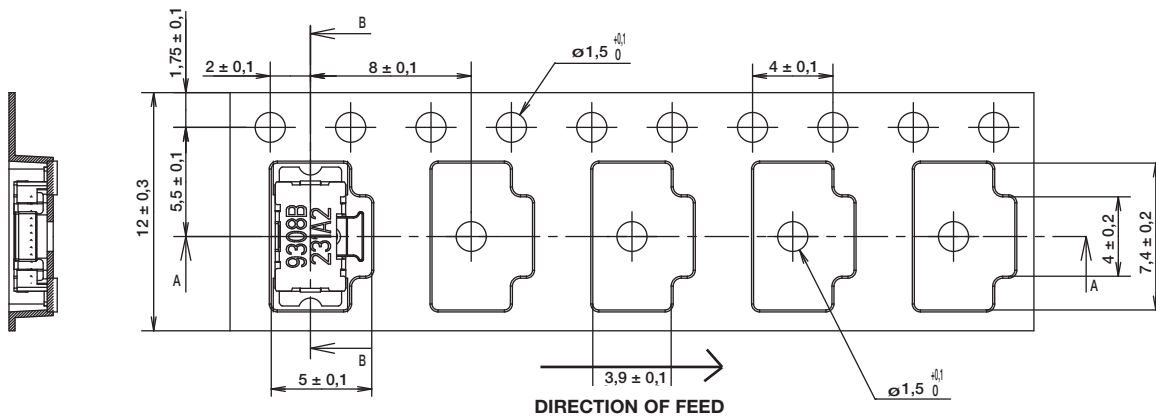

First Angle
Projection

Dimensions are shown: mm
Specifications and dimensions subject to change

KSC Series Sealed Tact Switch for SMT

Features/Benefits

- Positive tactile feeling
- J or G terminations
- Various heights
- IP67

Typical Applications

- Automotive
- Cellular phones
- Industrial electronics
- Network infrastructure and IT
- Elevator

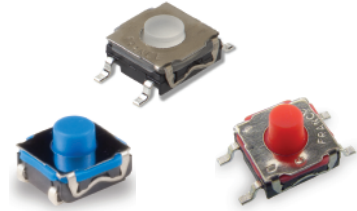

Specification

FUNCTION: Momentary action
 CONTACT ARRANGEMENT: 1 make contact = SPST, N.O.
 TERMINALS: J bend & Gullwing type for SMT
 SEALING: IP67 except KSC5 (IP50)

Liability Limitation

This datasheet does not provide enough information for applications that require a certain level of quality or safety such as automotive, medical systems, or safety equipment. Please contact customer service for the contractual specification package.

Environmental

| | Silver | Gold |
|------------------------|---------------|----------------|
| OPERATING TEMPERATURE: | -40°C to 85°C | -40°C to 125°C |
| STORAGE TEMPERATURE: | -55°C to 85°C | -55°C to 125°C |

Process

- SOLDERING: Depending on the application, this component is suited to the following methods:
- Terminals being silver or gold plated over a nickel barrier, the use of slightly activated flux is suitable.
 - Soldering on double wave machine for vertical versions: soldering time ≤ 5 sec.
 - Cleaning according to typical washing processes.
 - Infrared Reflow Soldering in accordance with IEC 61760-1.

Electrical

| | Silver | Gold |
|------------------|--------|--------|
| MAXIMUM POWER: | 1 VA | 0.2 VA |
| MAXIMUM VOLTAGE: | 32 VDC | 32 VDC |
| MINIMUM VOLTAGE: | 20 mV | 20 mV |
| MAXIMUM CURRENT: | 50 mA | 10 mA |
| MINIMUM CURRENT: | 1 mA* | 0.1 mA |

DIELECTRIC STRENGTH (50 Hz, 1 min.): ≥ 250 Vrms
 CONTACT RESISTANCE: ≤ 100mΩ
 INSULATION RESISTANCE (100 V): ≥ 10M Ω
 BOUNCE TIME: ≤ 1 ms

* Ultra low current with 10 µA - 1 VDC version are available upon request for KSC2 and KSC4

Packaging

Tape and Reel (see series for quantity information)

NOTE: Specifications listed above are for switches with standard options.

KSC Product Range

| KSC1 | KSC2 | KSC3 | KSC4 | KSC5 | KSC6 | KSC7 | KSC8 | KSC9 | KSC10 |
|------------------|---------------|---------------|---------------|---------------|---------------|---------------|---------------|-----------------------------------|---------------|
| Without actuator | Soft actuator | Hard actuator | Soft actuator | Hard actuator | Hard actuator | Soft actuator | Hard actuator | Hard actuator | Soft actuator |
| H = 2.5 mm | H = 3.5 mm | H = 3.5 mm | H = 5.2 mm | H = 5.6 mm | H = 7.7 mm | H = 4.3 mm | H = 4.9 mm | H = 7.7 mm compatible with button | H = 4.9 mm |
| IP67 | IP67 | IP67 | IP67 | IP50 | IP67 | IP67 | IP67 | IP67 | IP67 |



Note: KSC Series is subject to variants. Please contact customer service for other options.

KSC Series Sealed Tact Switch for SMT

J BEND

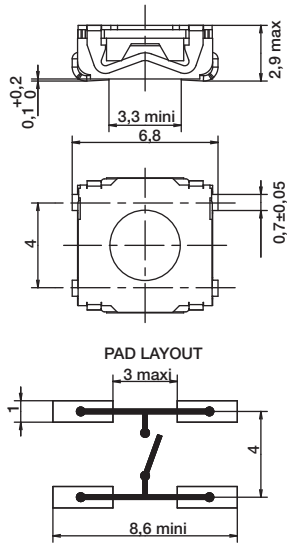

G GULLWING

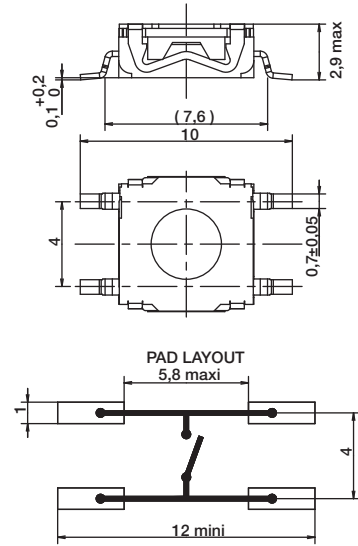

12 MM

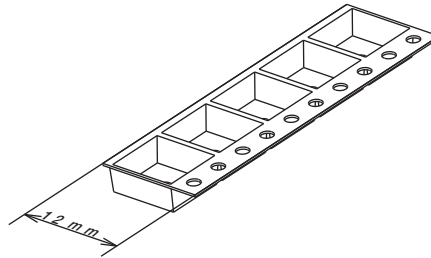
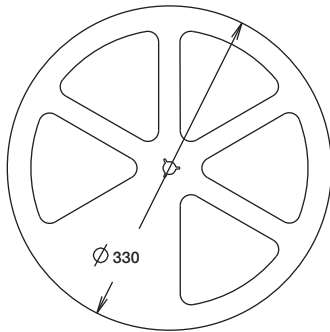

16 MM

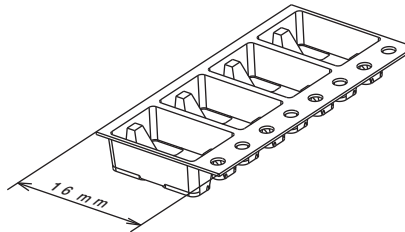
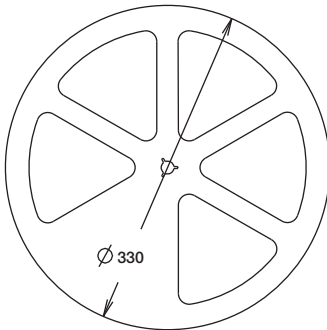

| 12 mm | Pieces | 16 mm | Pieces |
|-------|--------|------------|--------|
| KSC1J | 2,000 | KSC1G | 2,000 |
| KSC2J | 2,000 | KSC2G | 2,000 |
| KSC3J | 2,000 | KSC3G | 2,000 |
| | | KSC4J & G | 1,000 |
| | | KSC5J & G | 1,000 |
| | | KSC6J & G | 750 |
| | | KSC7J & G | 1,000 |
| | | KSC8J & G | 1,000 |
| | | KSC9J & G | 750 |
| | | KSC10J & G | 1,000 |



First Angle
Projection

Dimensions are shown: mm
Specifications and dimensions subject to change

KSC1 Series Sealed Tact Switch for SMT

KSC1 without actuator 2,5 mm high



| Type | Operating force FA (Newtons) | Operating life (operations) | Travel (mm) |
|--------|------------------------------|-----------------------------|-------------|
| KSC121 | 1.8 ± 0.65 | 200,000 | 0.3 ± 0.15 |
| KSC141 | 3 ± 0.75 | 200,000 | 0.3 ± 0.15 |
| KSC151 | 5.5 ± 1.4 | 100,000 | 0.35 ± 0.15 |

Packaging

Switches delivered on continuous tape & reels of 2,000 pieces
 Dimensions according to EIA RS-481/ IEC 60286-3 standard
 External diameter 330 ± 2 mm

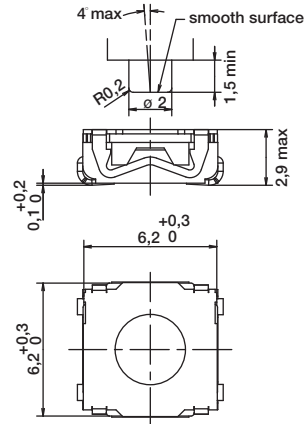

B
Tactile Switches

How To Order

Our easy build-a-switch concept allows you to mix and match options to create the switch you need. To order, select desired option from each category and place it in the appropriate box.

However, please note that all the combinations of these options are not feasible.

For any part number different from those listed above, please consult your local representative.

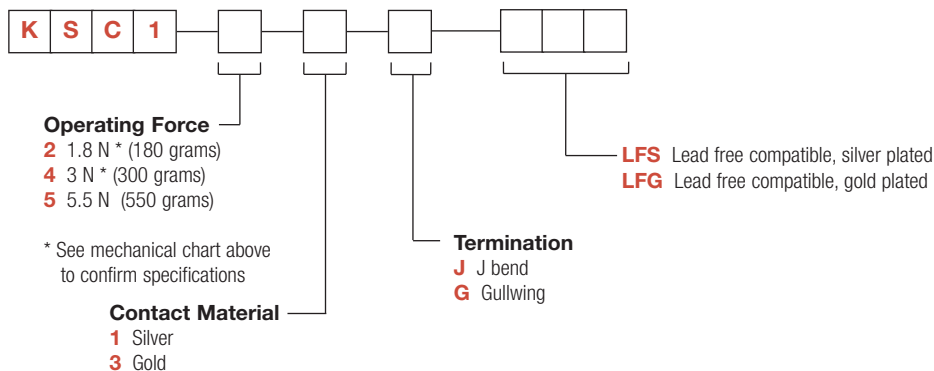

Dimensions are shown: mm
 Specifications and dimensions subject to change

KSC2 Series Sealed Tact Switch for SMT

KSC2 soft actuator 3,5 mm high



B

Tactile Switches

| Type | Operating force FA (Newtons) | Operating life (operations) | Travel (mm) |
|------------|------------------------------|-----------------------------|------------------|
| KSC201 | 1.6 ± 0.6 | 5,000,000 | 0.3 ± 0.2 |
| KSC221 | 2 ± 0.5 | 500,000 | 0.35 + 0.3/- 0.1 |
| KSC222 | 2 ± 0.5 | 1,000,000 | 0.35 ± 0.15 |
| KSC241 | 3.5 ± 0.9 | 300,000 | 0.5 ± 0.2 |
| KSC251 | 5.55 ± 1.45 | 300,000 | 0.5 ± 0.2 |
| KSC231 SPD | 3.5 ± 0.9 | 300,000 | 0.5 ± 0.2 |
| KSC241 SPD | 3.55 ± 0.9 | 300,000 | 0.5 ± 0.2 |
| KSC251 SPD | 6.2 ± 1.55 | 100,000 | 0.6 ± 0.2 |

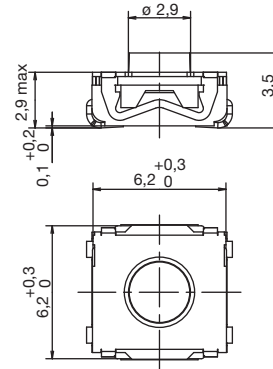

Packaging

Switches delivered on continuous tape & reels of 2,000 pieces
Dimensions according to EIA RS-481/ IEC 60286-3 standard
External diameter 330 ± 2 mm

How To Order

Our easy build-a-switch concept allows you to mix and match options to create the switch you need. To order, select desired option from each category and place it in the appropriate box.

However, please note that all the combinations of these options are not feasible.

For any part number different from those listed above, please consult your local representative.

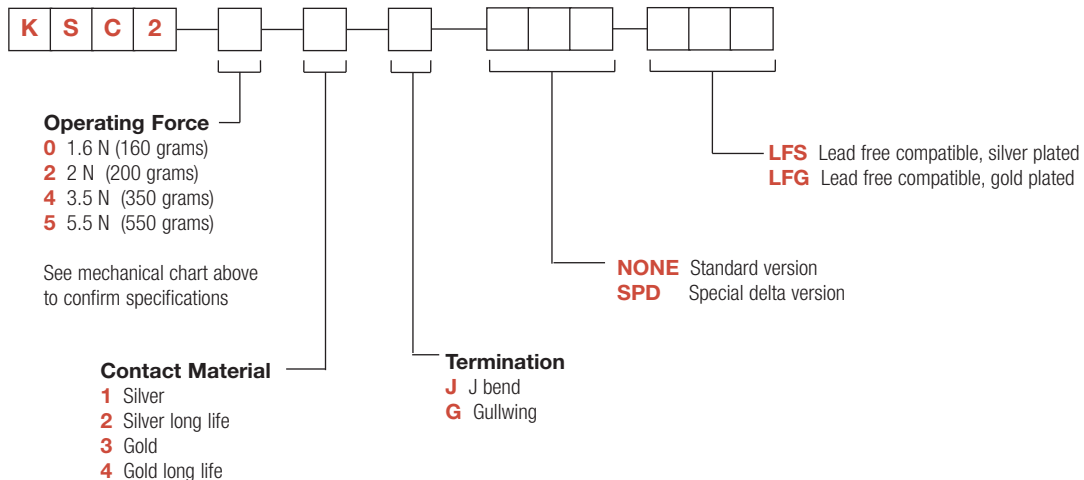

Dimensions are shown: mm
Specifications and dimensions subject to change

KSC3 Series Sealed Tact Switch for SMT

KSC3 hard actuator 3,5 mm high



| Type | Operating force FA (Newtons) | Operating life (operations) | Travel (mm) |
|--------|------------------------------|-----------------------------|----------------|
| KSC321 | 2 ± 0.4 | 300,000 | 0.2 + 0.3/- 0 |
| KSC341 | 3 ± 0.75 | 300,000 | 0.2 + 0.3/- 0 |
| KSC351 | 5 ± 1 | 100,000 | 0.25 + 0.3/- 0 |

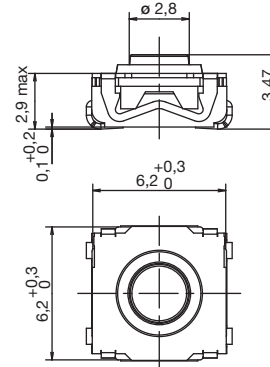

Packaging

Switches delivered on continuous tape & reels of 2,000 pieces
Dimensions according to EIA RS-481/ IEC 60286-3 standard
External diameter 330 ± 2 mm

How To Order

Our easy build-a-switch concept allows you to mix and match options to create the switch you need. To order, select desired option from each category and place it in the appropriate box.

However, please note that all the combinations of these options are not feasible.

For any part number different from those listed above, please consult your local representative.

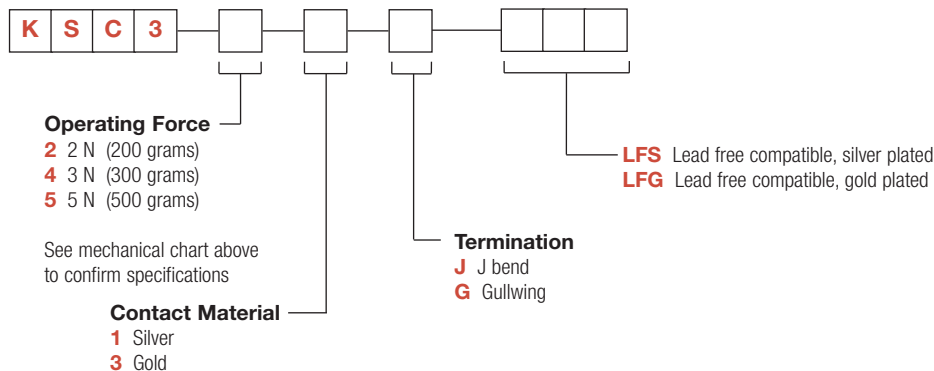

KSC4 Series

Sealed Tact Switch for SMT

KSC4 soft actuator 5,2 mm high

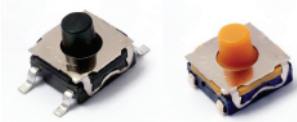

B

Tactile Switches

| Type | Operating force FA (Newtons) | Operating life (operations) | Travel (mm) |
|-------------|------------------------------|-----------------------------|-------------|
| KSC401 50SH | 1.45 ± 0.55 | 5,000,000 | 0.5 ± 0.25 |
| KSC411 70SH | 1.4 ± 0.35 | 1,000,000 | 0.35 ± 0.20 |
| KSC421 70SH | 1.7 ± 0.45 | 300,000 | 0.5 ± 0.25 |
| KSC422 70SH | 1.7 ± 0.45 | 1,000,000 | 0.5 ± 0.25 |
| KSC441 70SH | 4 ± 1 | 300,000 | 0.75 ± 0.25 |
| KSC442 70SH | 4 ± 1 | 1,000,000 | 0.75 ± 0.25 |
| KSC451 70SH | 4.25 ± 0.75 | 300,000 | 0.8 ± 0.2 |
| KSC441 SPD | 3.5 ± 0.9 | 300,000 | 0.7 ± 0.2 |
| KSC441 ST1 | 3.4 ± 1 | 300,000 | 0.7 ± 0.25 |
| KSC441 ST2 | 3.4 ± 1 | 300,000 | 0.35 ± 0.20 |
| KSC461 ST1 | 6.25 ± 1.75 | 100,000 | 1 ± 0.3 |
| KSC461 ST2 | 6.25 ± 1.75 | 300,000 | 0.5 ± 0.2 |

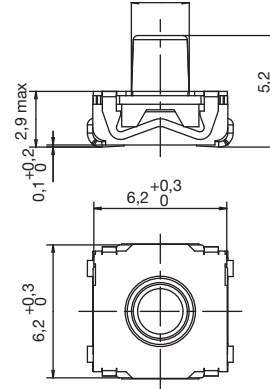

Packaging

Switches delivered on continuous tape & reels of 1,000 pieces
 Dimensions according to EIA RS-481/ IEC 60286-3 standard
 External diameter 330 ± 2 mm

How To Order

Our easy build-a-switch concept allows you to mix and match options to create the switch you need. To order, select desired option from each category and place it in the appropriate box.

However, please note that all the combinations of these options are not feasible.
 For any part number different from those listed above, please consult your local representative.

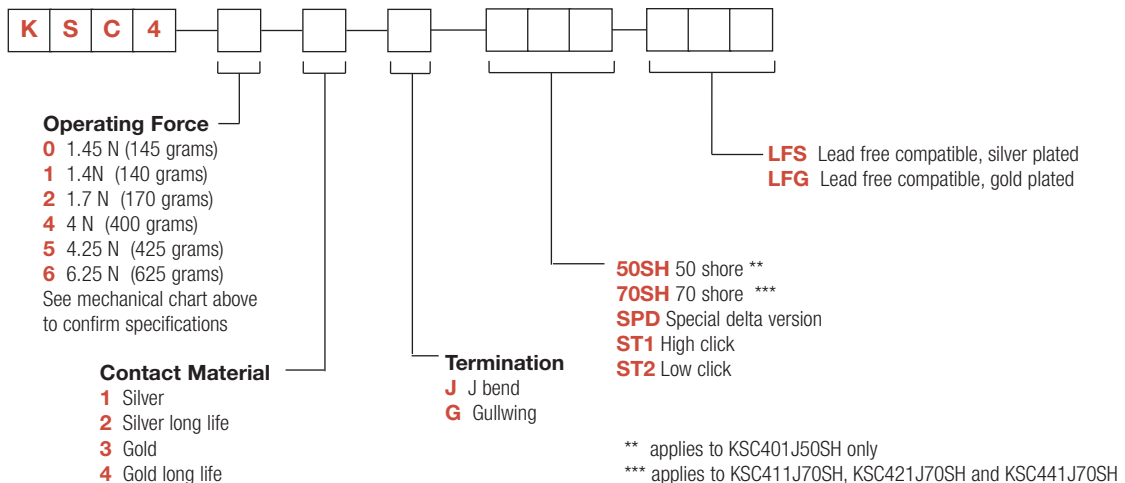

Dimensions are shown: mm

Specifications and dimensions subject to change



KSC5 Series Tact Switch with Rocker Option for SMT

KSC5 hard actuator 5,6 mm high



| Type | Operating force axial FA N (grams) | Operating force lateral FL N (grams) ±30% | Travel to make axial (mm) | Travel to make lateral (mm) | Life expectancy cycles, axial | Life expectancy cycles, lateral |
|--------|---------------------------------------|--|---------------------------|-----------------------------|-------------------------------|---------------------------------|
| KSC521 | 2 ± 0.5 | 1.2 - 2.6 | 0.25 ± 0.15 | 0.5 ± 0.25 | 100,000 | 10,000 |
| KSC541 | 3 ± 0.75 | 1.8 - 3.8 | 0.25 ± 0.15 | 0.5 ± 0.25 | 100,000 | 10,000 |

Packaging

Switches delivered on continuous tape & reels of 1,000 pieces, dimensions according to EIA RS-481/ IEC 60286-3 standard
External diameter 330 ± 2 mm

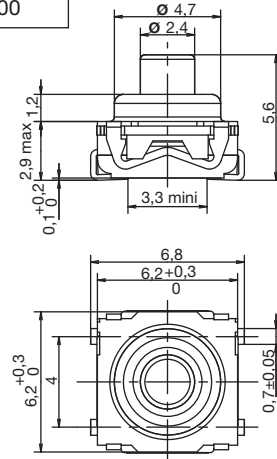

How To Order

Our easy build-a-switch concept allows you to mix and match options to create the switch you need. To order, select desired option from each category and place it in the appropriate box.

However, please note that all the combinations of these options are not feasible.

For any part number different from those listed above, please consult your local representative.

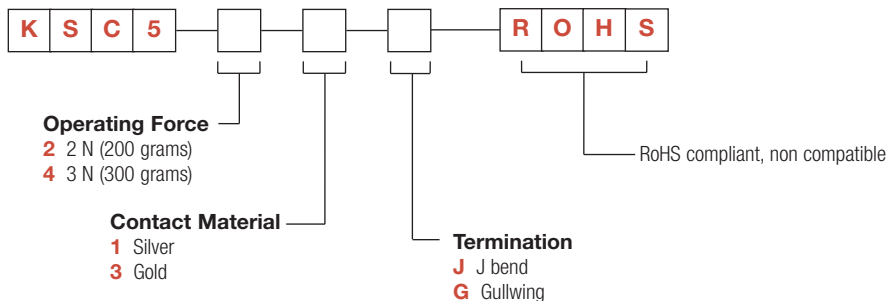

KSC6 Series Sealed Tact Switch for SMT

KSC6 hard actuator 7,7 mm high



| Type | Operating force FA (Newtons) | Operating life (operations) | Travel (mm) |
|--------|------------------------------|-----------------------------|-------------|
| KSC621 | 1.7 ± 0.5 | 300,000 | 0.4 ± 0.2 |
| KSC631 | 2.55 ± 0.65 | 300,000 | 0.4 ± 0.2 |
| KSC641 | 3.4 ± 0.85 | 300,000 | 0.4 ± 0.2 |

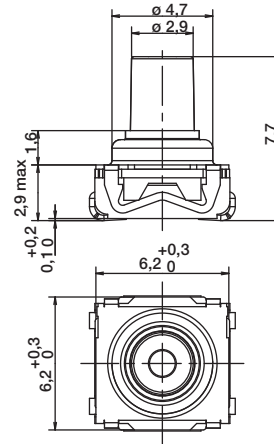

Tactile Switches

Packaging

Switches delivered on continuous tape & reels of 750 pieces
Dimensions according to EIA RS-481/ IEC 60286-3 standard
External diameter 330 ± 2 mm

How To Order

Our easy build-a-switch concept allows you to mix and match options to create the switch you need. To order, select desired option from each category and place it in the appropriate box.

However, please note that all the combinations of these options are not feasible.

For any part number different from those listed above, please consult your local representative.

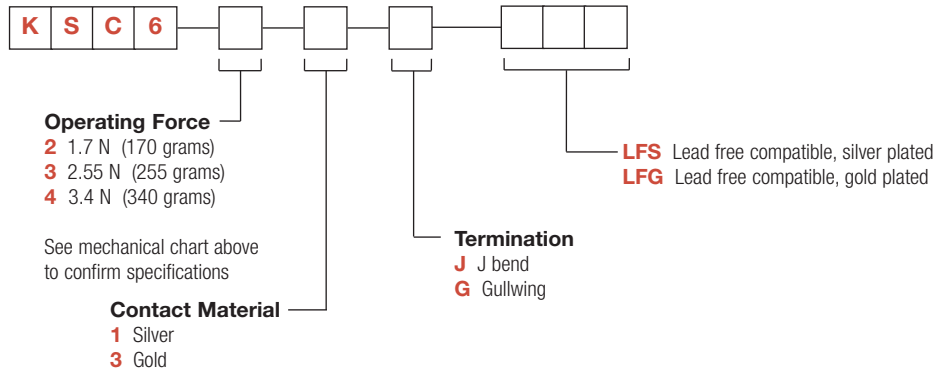

Dimensions are shown: mm
Specifications and dimensions subject to change

KSC7 Series Tact Switch with Rocker Option for SMT

KSC7 soft actuator 4,3 mm high

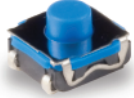

| Type | Operating force FA (Newtons) | Operating life (operations) | Travel (mm) |
|--------|------------------------------|-----------------------------|-------------|
| KSC701 | 1.6 ± 0.6 | 5,000,000 | 0.3 ± 0.2 |
| KSC721 | 2.25 ± 0.55 | 300,000 | 0.3 ± 0.15 |
| KSC741 | 3.9 ± 1 | 300,000 | 0.4 ± 0.2 |

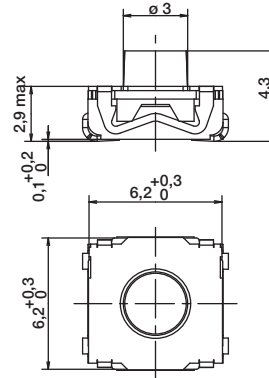

Packaging

Switches delivered on continuous tape & reels of 1,000 pieces
 Dimensions according to EIA RS-481/ IEC 60286-3 standard
 External diameter 330 ± 2 mm

How To Order

Our easy build-a-switch concept allows you to mix and match options to create the switch you need. To order, select desired option from each category and place it in the appropriate box.

**However, please note that all the combinations of these options are not feasible.
 For any part number different from those listed above, please consult your local representative.**

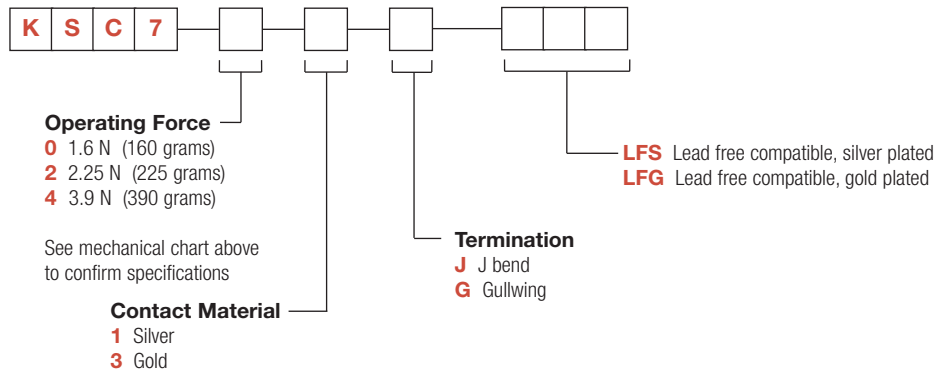

KSC8 Series Sealed Tact Switch for SMT

KSC8 hard actuator 4,9 mm high



| Type | Operating force FA (Newtons) | Operating life (operations) | Travel (mm) |
|-----------|------------------------------|-----------------------------|-------------|
| KSC821 | 3.15 ± 0.75 | 300,000 | 0.65 ± 0.2 |
| KSC821 OL | 1.7 ± 0.5 | 300,000 | 0.4 ± 0.2 |
| KSC831 OL | 2.55 ± 0.65 | 300,000 | 0.4 ± 0.2 |
| KSC841 OL | 3.4 ± 0.85 | 300,000 | 0.4 ± 0.2 |

Packaging

Switches delivered on continuous tape & reels of 1,000 pieces
Dimensions according to EIA RS-481/ IEC 60286-3 standard
External diameter 330 ± 2 mm

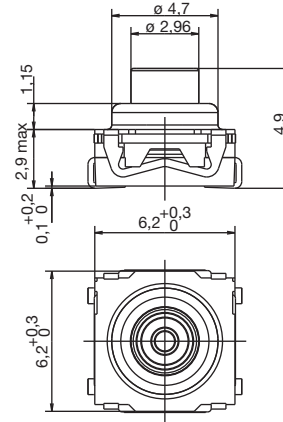

Tactile Switches

How To Order

Our easy build-a-switch concept allows you to mix and match options to create the switch you need. To order, select desired option from each category and place it in the appropriate box.

However, please note that all the combinations of these options are not feasible.
For any part number different from those listed above, please consult your local representative.

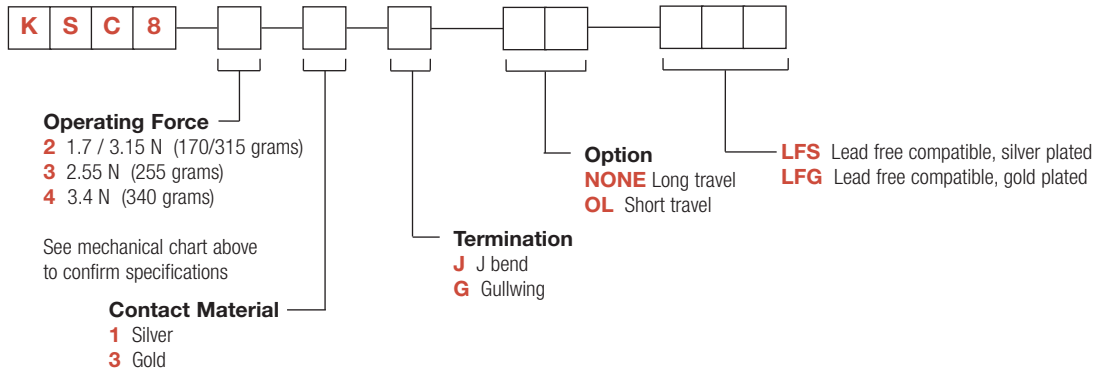

Dimensions are shown: mm
Specifications and dimensions subject to change

KSC9 Series Sealed Tact Switches for SMT

KSC9 hard actuator 7,7 mm high



| Type | Operating force FA (Newtons) | Operating life (operations) | Travel (mm) |
|--------|------------------------------|-----------------------------|-------------|
| KSC921 | 1.7 ± 0.5 | 300,000 | 0.4 ± 0.2 |
| KSC931 | 2.25 ± 0.65 | 300,000 | 0.4 ± 0.2 |
| KSC941 | 3.4 ± 0.85 | 300,000 | 0.4 ± 0.2 |

Packaging

Switches delivered on continuous tape & reels of 750 pieces
Dimensions according to EIA RS-481/ IEC 60286-3 standard
External diameter 330 ± 2 mm

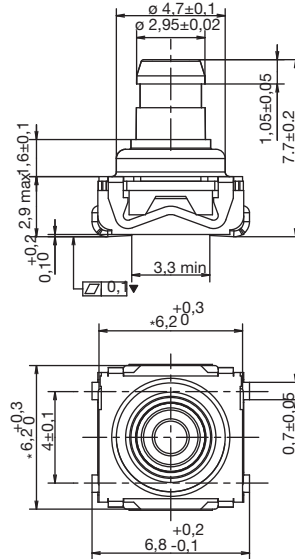

How To Order

Our easy build-a-switch concept allows you to mix and match options to create the switch you need. To order, select desired option from each category and place it in the appropriate box.

For any part number different from those listed above, please consult your local representative.

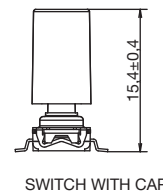
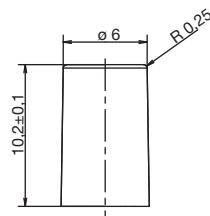
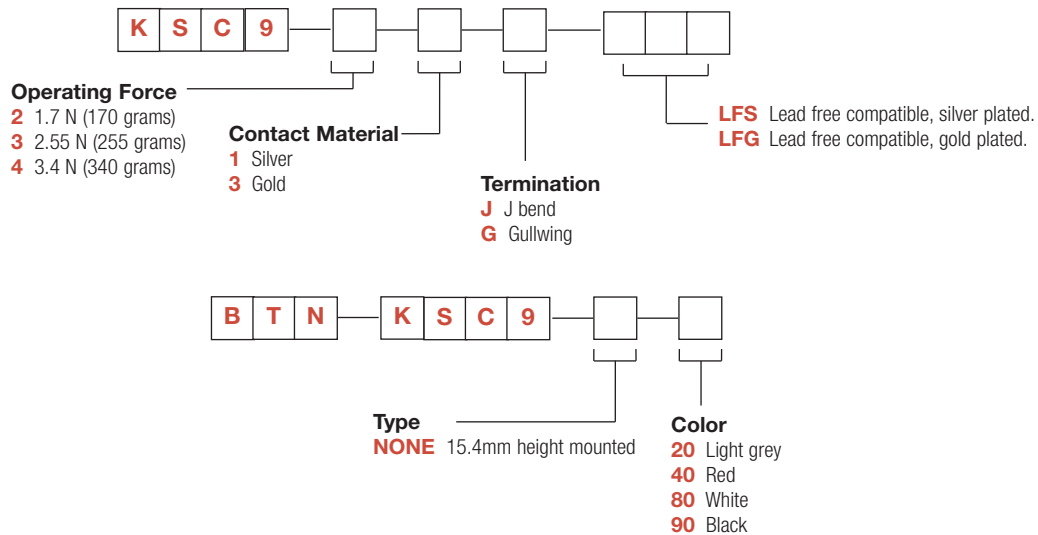

Dimensions are shown: mm
Specifications and dimensions subject to change

KSC10 Series

Sealed Tact Switches for SMT

KSC10 soft actuator 4,9 mm high



Tactile Switches

| Type | Operating force FA (Newtons) | Operating life (operations) | Travel (mm) |
|---------|------------------------------|-----------------------------|-------------|
| KSC1001 | 1.45 ± 0.55 | 5,000,000 | 0.45 ± 0.25 |

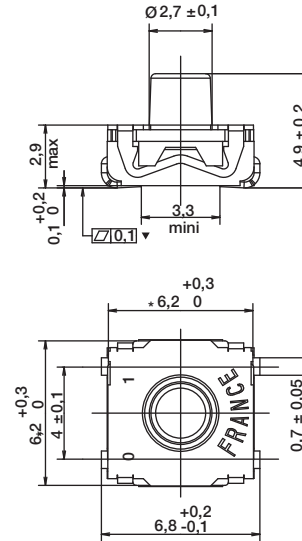

Packaging

Switches delivered on continuous tape & reels of 1,000 pieces
 Dimensions according to EIA RS-481/ IEC 60286-3 standard
 External diameter 330 ± 2 mm

How To Order

Our easy build-a-switch concept allows you to mix and match options to create the switch you need. To order, select desired option from each category and place it in the appropriate box.

However, please note that all the combinations of these options are not feasible.
For any part number different from those listed above, please consult your local representative.

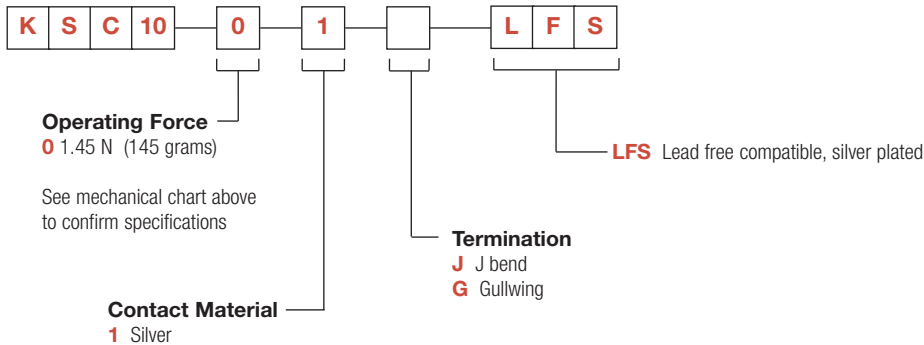

Note: KSC10 offered with yellow actuator as standard, hardness 55 Shore



Dimensions are shown: mm
 Specifications and dimensions subject to change

KSC4V2 Series Side Actuated Sealed Tact Switch

Features/Benefits

- Full SMD side actuated
- Haptic adaptability
- Pin in paste terminations
- Tape & reel
- IP67

Typical Applications

- Automotive
- Industrial electronics
- Network equipment
- Telecommunications



Specification

FUNCTION: momentary action
 CONTACT ARRANGEMENT: 1 make contact = SPST, N.O.
 TERMINALS:
 2 pin in paste signal terminals
 3 SMD ground terminals

Mechanical

| Type | Force (N) | Operating Life (operations) | Travel (mm) |
|-----------------|-------------|-----------------------------|-------------|
| KSC441V2SPDLFS | 3.5 ± 1.0 | 300,000 | 0.7 ± 0.2 |
| KSC421V270SHLFS | 1.55 ± 0.45 | 300,000 | 0.5 ± 0.2 |

NOTE: Basic version is based on KSC441V2 SPDELTA LFS.
 Other configurations of haptics are available upon demand.

MISUSE OVERLOAD: 40N with back support
 SHEAR FORCE: 10N without back support

Electrical

| | Silver | Gold |
|------------------|--------|--------|
| MAXIMUM POWER: | 1 VA | 0.2 VA |
| MAXIMUM VOLTAGE: | 32 VDC | 32 VDC |
| MINIMUM VOLTAGE: | 20 mV | 20 mV |
| MAXIMUM CURRENT: | 50 mA | 10 mA |
| MINIMUM CURRENT: | 1 mA | 0.1 mA |

DIELECTRIC STRENGTH (50 Hz, 1 min.): ≥ 250 Vrms
 CONTACT RESISTANCE: ≤ 100 mΩ
 INSULATION RESISTANCE (100 V, initial stage): > 10⁹ Ω
 BOUNCE TIME: < 1 ms

Environmental

| | Silver | Gold |
|------------------------|---------------|----------------|
| OPERATING TEMPERATURE: | -40°C to 85°C | -40°C to 125°C |
| STORAGE TEMPERATURE: | -55°C to 85°C | -55°C to 125°C |

Process

SOLDERING: Depending on the application, this component is suited to the following methods:

- Cleaning according to typical washing processes.
- Infrared Reflow Soldering in accordance with IEC 61760-1.

TERMINALS: pin in paste, silver or gold plated

TOP PLATE: tin plated

MSL level: 1

Vacuum pick head mandatory

Packaging

In reels of 500 pieces.

Dimensions of reels according to EIA RS481 or IEC 2863.

External diameter 330 mm ± 2 mm.

NOTE: This product is designed and manufactured for general electronic devices.
 For systems where reliability and safety are required, please contact your sales representative to secure product integration and function to secure usage.

How To Order

Our easy build-a-switch concept allows you to mix and match options to create the switch you need. To order, select desired option from each category and place it in the appropriate box.

For any part number different from those listed above, please consult your local representative.

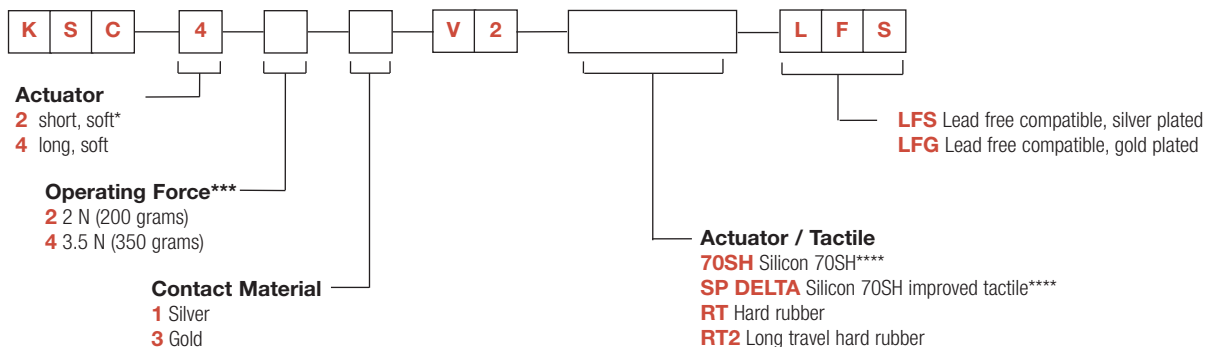

* KSC2 version available upon demand
 *** Force available upon demand (variant version)
 **** Available for KSC4 only

KSC4V2 Series

Side Actuated Sealed Tact Switch

Tactile Switches

B

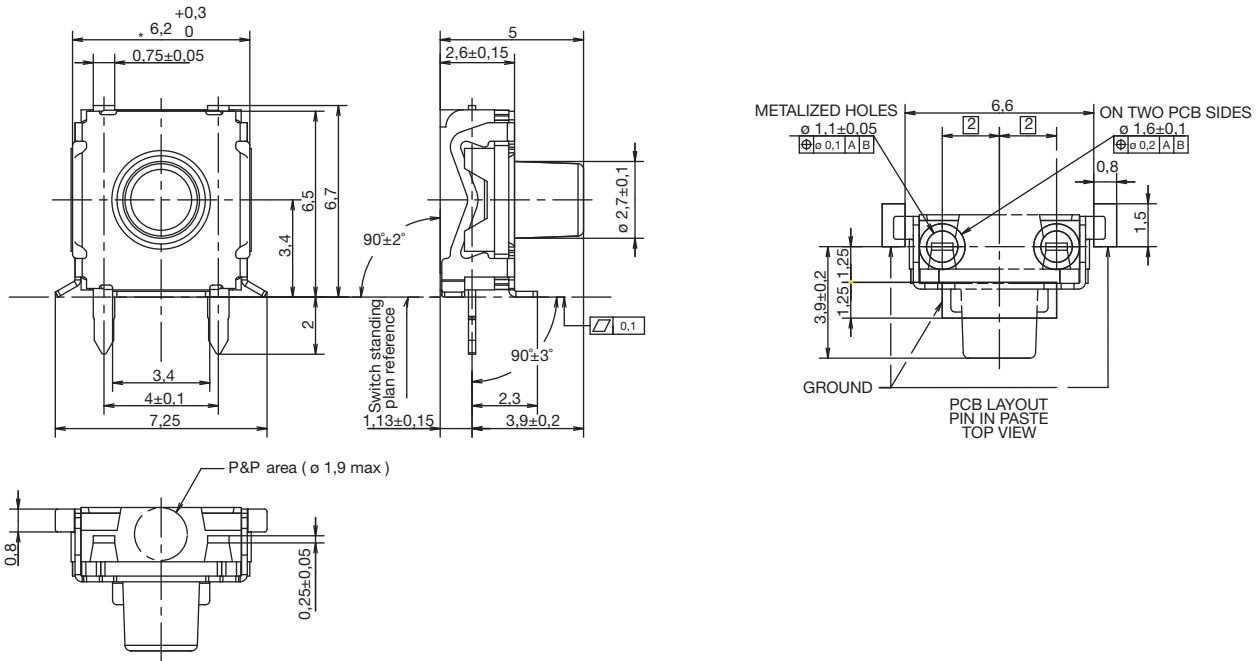

TAPE AND REEL

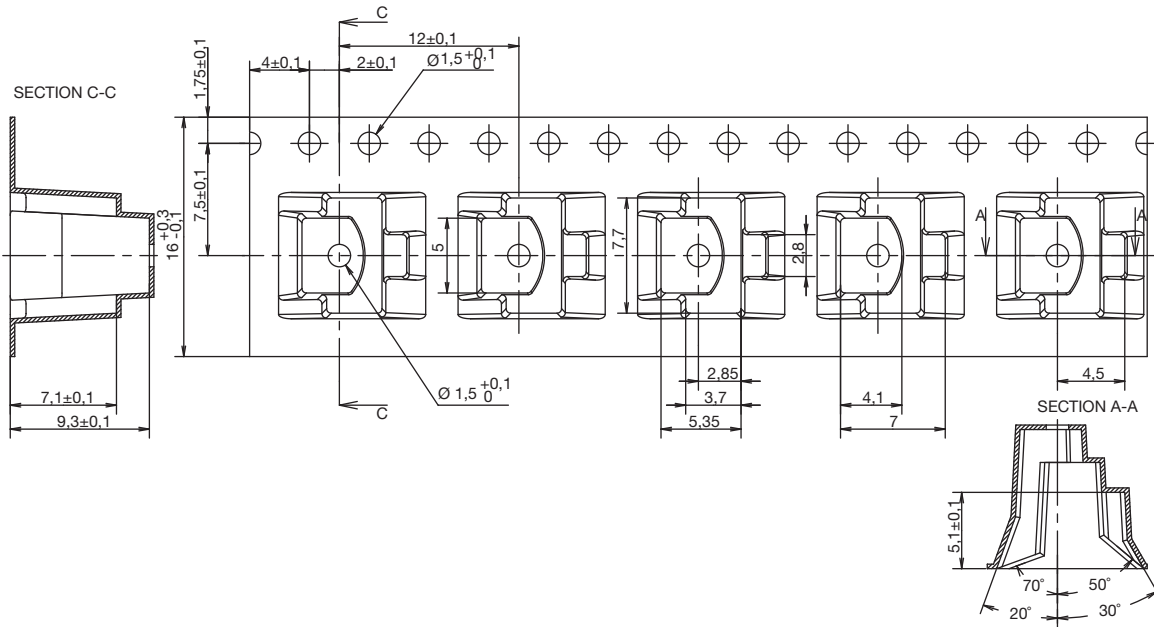

INTEGRATION

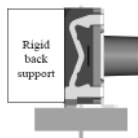

First Angle Projection

Dimensions are shown: mm
Specifications and dimensions subject to change

KSE Series Low Profile Tact Switch

Features/Benefits

- Low profile
- Cost efficient
- J or G terminations
- Tape and reel
- IP67

Typical Applications

- Smart meters
- Home appliances
- Consumer electronics
- Industrial electronics
- Telecommunications

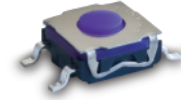

Specification

FUNCTION: momentary action
CONTACT ARRANGEMENT: 1 make contact = SPST, N.O.
TERMINALS: J bend & Gullwing type for SMT

Mechanical

| Type | Operating Force FA (Newtons) | | Operating Life Operations | Travel (mm) |
|------------|------------------------------|------|---------------------------|----------------|
| | Min. | Max. | | |
| KSEM31JLFS | 1,6 ± 0,6 | | 300,000 | 0,3 + 0,1/-0,2 |
| KSEM31GLFS | 1,6 ± 0,6 | | 300,000 | 0,3 + 0,1/-0,2 |
| KSEK43JLFS | 2,25 ± 0,75 | | 300,000 | 0,3 ± 0,2 |
| KSEK43GLFS | 2,25 ± 0,75 | | 300,000 | 0,3 ± 0,2 |

NOTE: For cost effectiveness the tactile feeling is not specified and can change along production. If your application requires a defined tactile effect, please consider KSC series for your application.

Packaging

In reels of 2,000 pieces
Dimensions of reels according to EIA RS481 or IEC 2863.
External diameter 330 mm ± 2 mm.

Electrical

MAXIMUM POWER: 1 VA
MINIMUM/MAXIMUM VOLTAGE: 20 mV / 32 VDC
MINIMUM/MAXIMUM CURRENT: 1 mA / 50 mA
DIELECTRIC STRENGTH: (50 Hz, 1 min.): ≥ 250 V
CONTACT RESISTANCE: ≤ 100 mΩ
INSULATION RESISTANCE: (100 V): ≥ 10⁹ Ω
BOUNCE TIME: ≤ 1 ms

Environmental

OPERATING TEMPERATURE: -40°C to 85°C
STORAGE TEMPERATURE: -55°C to 85°C

Process

SOLDERING: Depending on the application, this component is suited to the following methods:
– Cleaning according to typical washing processes.
– Infrared Reflow Soldering in accordance with IEC 61760-1.

NOTE:

Specifications listed above are for switches with standard options. KSE series is not subject to adaptation and/or modification for specific use. If you require additional features, please refer to the KSC series. KSE is not recommended for applications requiring high level of performance such as aerospace, automotive and some industrial applications.

How To Order

Our easy build-a-switch concept allows you to mix and match options to create the switch you need. To order, select desired option from each category and place it in the appropriate box.

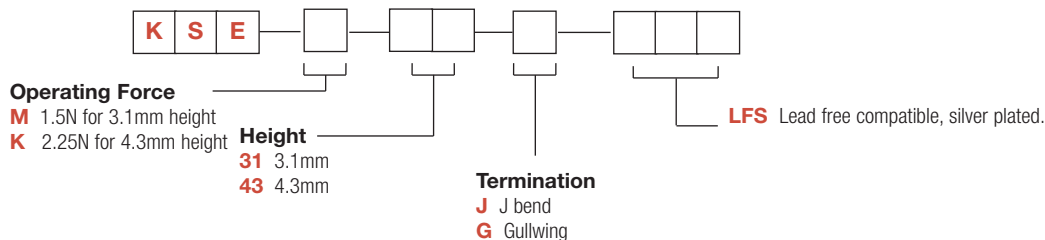

KSE Series Low Profile Tact Switch

HEIGHT

31 3.1 MM HEIGHT

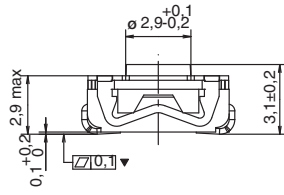

43 4.3 MM HEIGHT

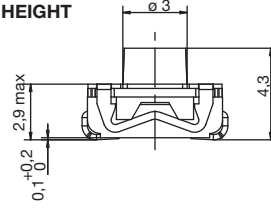

TERMINATION

G GULLWING

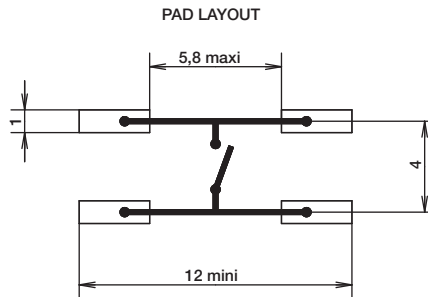
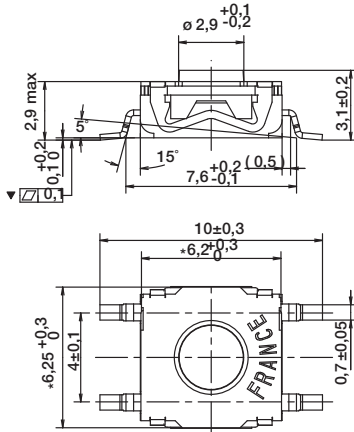

J J BEND

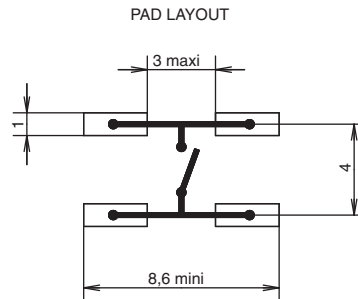
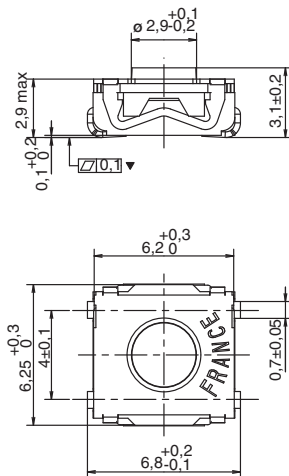

KSE Series Low Profile Tact Switch

TAPE & REEL

12 mm height

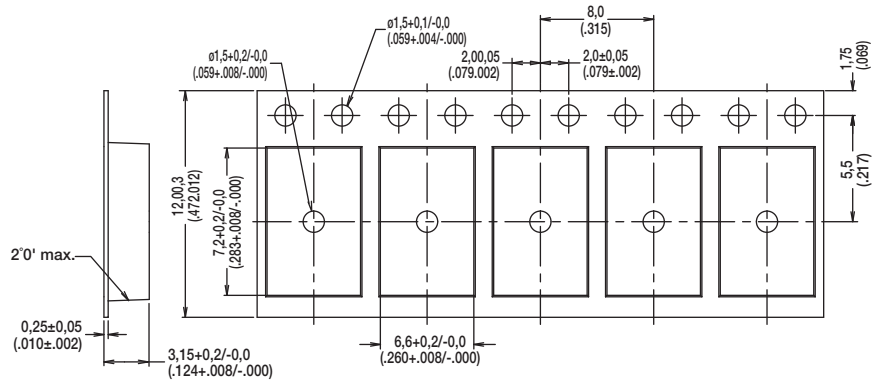

16 mm height

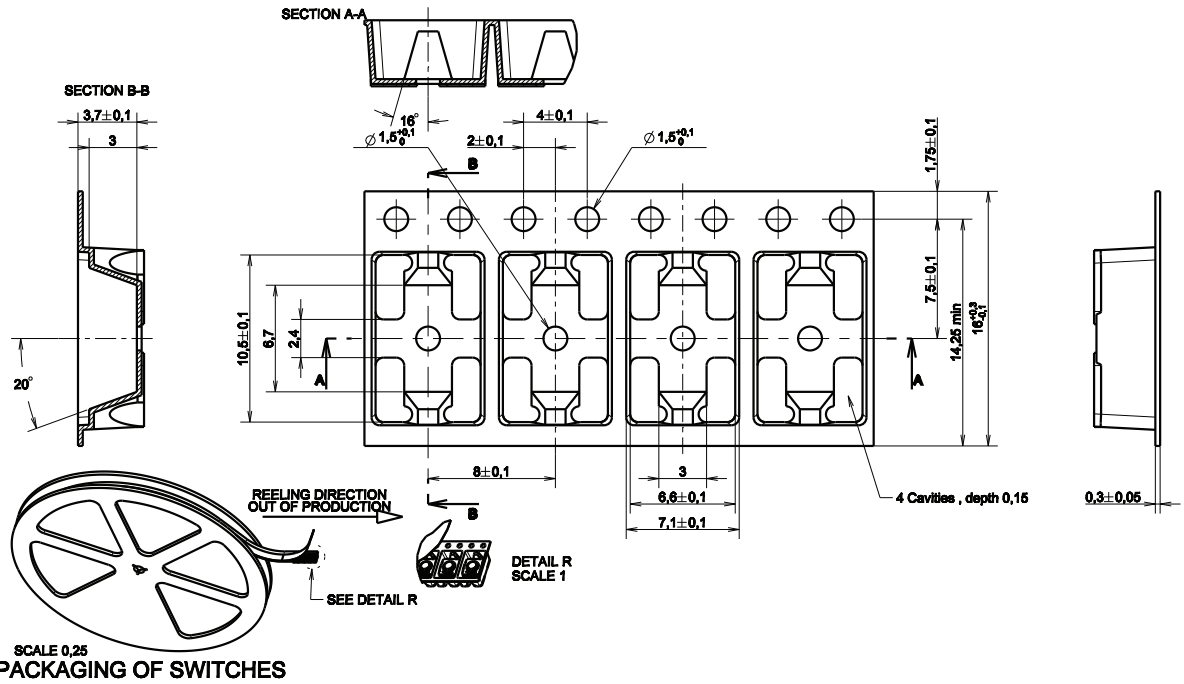

B
Tactile Switches

KT Series

Full SMT Top & Side Actuated Sealed Tact Switch



Features/Benefits

- Full SMT side-actuated tact switch
- SMT top-actuated tact switch with G or J terminations
- High shear force with extended bracket
- Easy to pick & place with top plate tab
- Rubber or hard plastic actuator
- Press fit or snap fit caps
- RoHS compliant and compatible

Typical Applications

- Telecommunications
- Computer products
- Instrumentation
- Power supply

Specification

CONTACT ARRANGEMENT: SPST, N.O.
TERMINALS: SMT termination

Electrical

CONTACT RATING: 1.0 VA max. @ 32 V AC or DC max.
ELECTRICAL & MECHANICAL LIFE: 100,000 make-and-break cycles at full load.
DIELECTRIC STRENGTH: 250 Vrms min. @ sea level.
CONTACT RESISTANCE: Below 50 mΩ typ. initial @ 2-4 V DC, 100 mA.
INSULATION RESISTANCE: 10⁹ Ω min.

Environmental

OPERATING TEMPERATURES: Ag version: -40°C to 90°C
Au version: -40°C to 125°C

Process

SOLDERABILITY: Per MIL-STD-202F method 208D, or EIA RS-186E method 9 (1 hour steam aging).
DEGREE OF PROTECTION: IP57; protection against harmful dust deposits, full-scale voltage protection.

Packaging

Switches supplied in anti-static tape and reels per EIA 481-2. Tape and cover strip are conductive for use near statically sensitive components.

NOTE: Specifications listed above are for switches with standard options. For information on specific and custom switches, consult Customer Service Center.

How To Order

Our easy build-a-switch concept allows you to mix and match options to create the switch you need. To order, select desired option from each category and place it in the appropriate box.

However, please note that all the combinations of these options are not feasible.

For any part number different from those listed above, please consult your local representative.

SWITCH

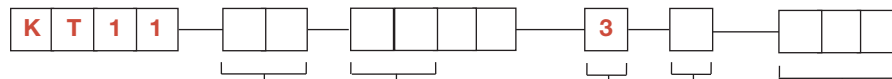

Actuator

- B0*** Soft, flush
- B1*** Soft, 0,64 mm
- B2*** Soft, 2,24 mm
- P2**** Hard, 2,36 mm
- P3**** Hard, 1,12 mm
- P4**** Hard, 3,96 mm
- S1***** ø0,1" for Press Fit Caps
- S2***** ø0,14" for Snap Fit Caps (with anti-rotation)

Orientation and Mounting Style

- SM** Top Gullwing
- JM** Top J Bend ****
- SAM** Right angle
- SA1M** Right angle with front solder pad
- SA2M** Right angle with front solder pad and pick & place tab
- SA3M** Right angle with pick & place tab

Contact Plating

- 4** Silver
- 5** Gold
- LFS** RoHS compliant and compatible. Silver plated
- LFG** RoHS compliant and compatible. Gold plated

* B0, B1 & B2 available with A, A1 & A3 mounting bracket only.
** P2, P3, P4 actuators suitable with A1 & A2 mounting bracket only.
*** S1 & S2 available with A1 & A2 mounting bracket only.
**** JM available with B0, B1, B2, P2, P3, P4 without mounting bracket.

BUTTON

To order buttons in bulk

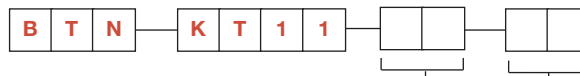

Button Style

- 02** Press fit
- 03** Snap fit, high temperature

Button Color

- 90** Black
- 80** Ivory (natural)
- 40** Red

KT Series Full SMT Top & Side Actuated Sealed Tact Switch

SERIES

KT11

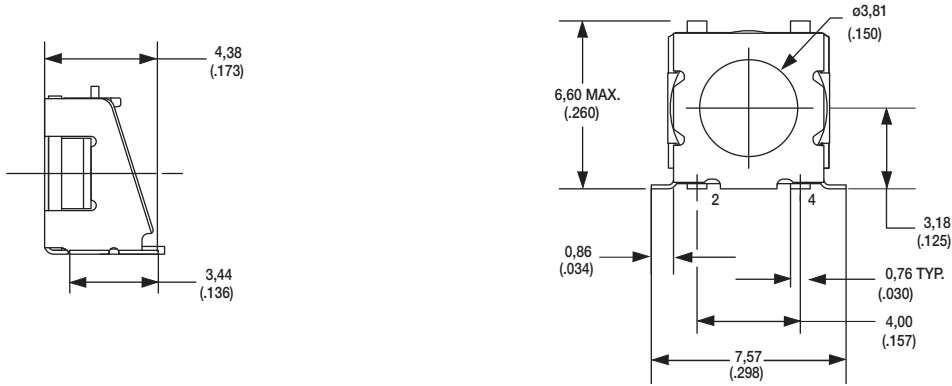

ACTUATOR

B0 SOFT, FLUSH*

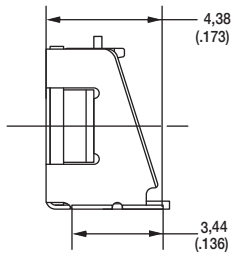

B1 SOFT, 0,64 mm*

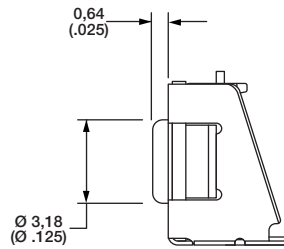

B2 SOFT, 2,24 mm*

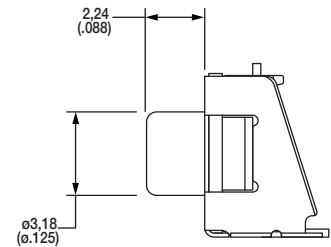

P2 HARD, 2,36 mm

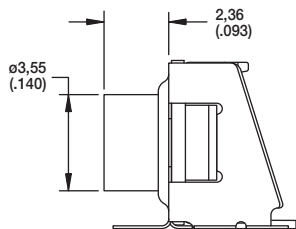

P3 HARD, 1,12 mm

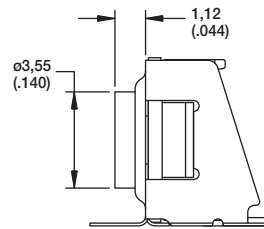

P4 HARD, 3,96 mm**

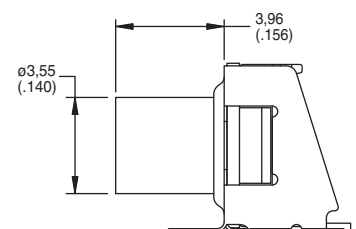

S1 \varnothing 0,1" FOR PRESS FIT CAPS***

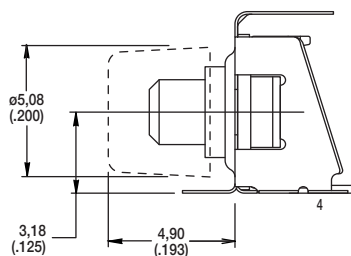

S2 \varnothing 0,14" FOR SNAP FIT CAPS***

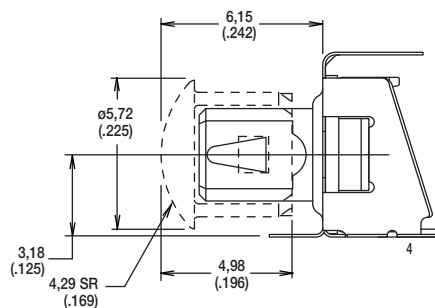

* B0, B1 & B2 available with A, A1 & A3 mounting bracket only.

** P2, P3, P4 actuators suitable with A1 & A2 mounting bracket only.

*** S1 & S2 available with A1 & A2 mounting bracket only.

**** JM available with B0, B1, B2, P2, P3, P4 without mounting bracket.



*Dimensions are shown: mm
Specifications and dimensions subject to change*

B

Tactile Switches

KT Series Full SMT Top & Side Actuated Sealed Tact Switch

ORIENTATION & MOUNTING STYLE

SM TOP GULLWING

JM TOP J BEND

Tactile Switches

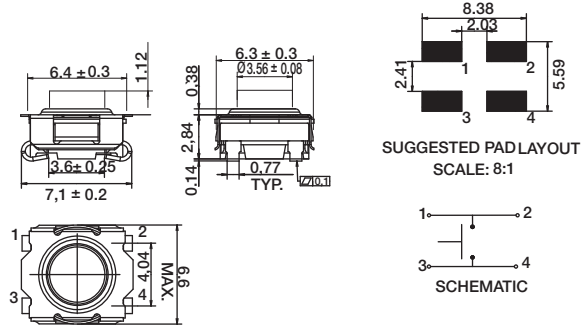
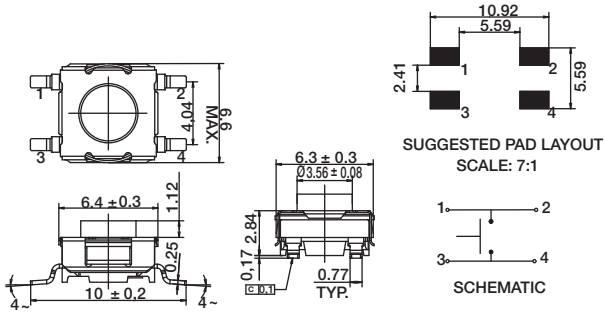

SAM RIGHT ANGLE

SA1M RIGHT ANGLE WITH FRONT SOLDER PAD

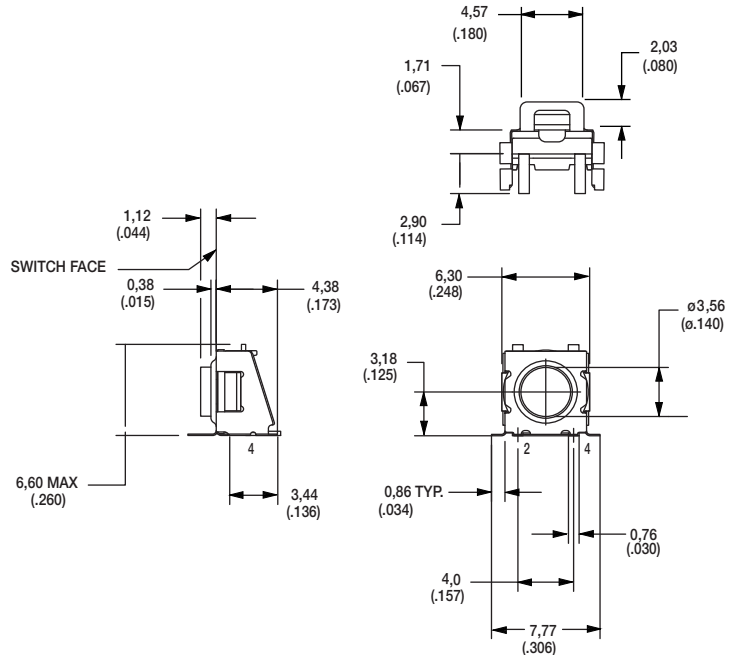
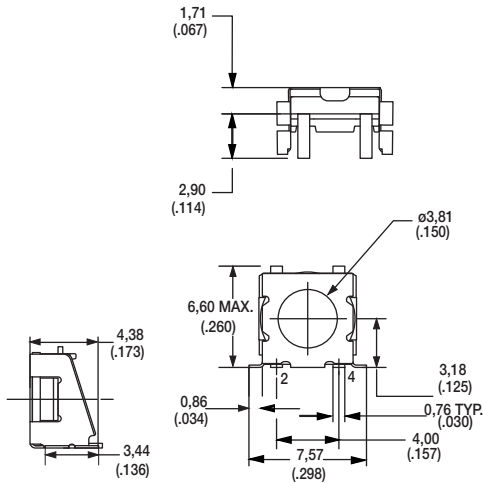

Dimensions are shown: mm
Specifications and dimensions subject to change

KT Series

Full SMT Top & Side Actuated Sealed Tact Switch

SA2M RIGHT ANGLE WITH FRONT SOLDER PAD AND PICK & PLACE TAB

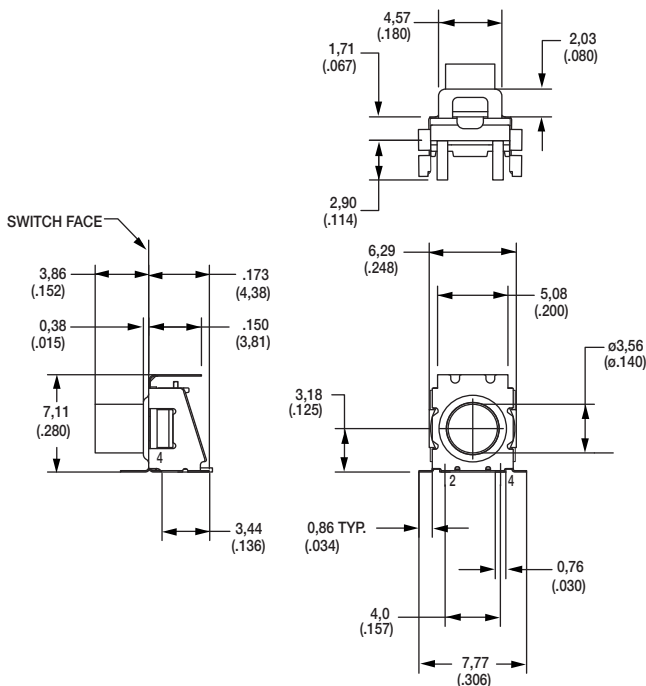

SA3M RIGHT ANGLE WITH PICK & PLACE TAB

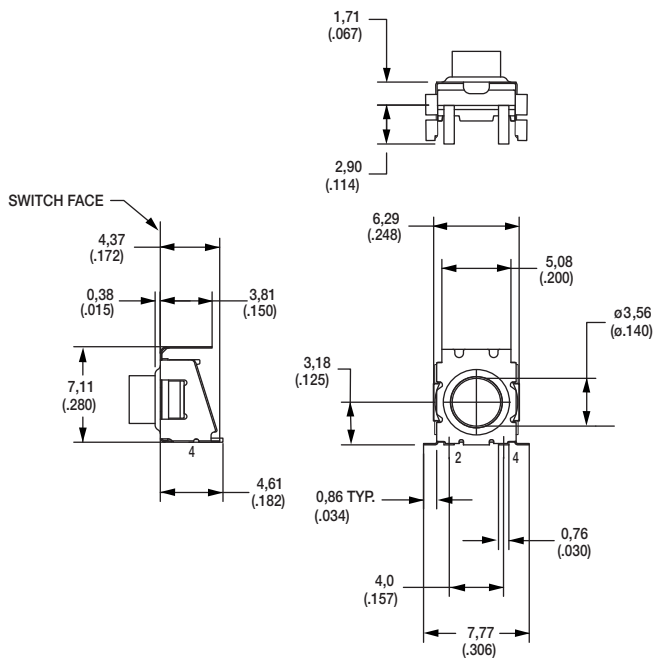

PAD LAYOUT
SA1M & SA2M MOUNTING BRACKET

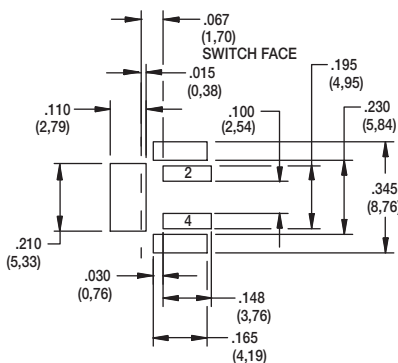

PAD LAYOUT
SAM & SA3M MOUNTING BRACKET

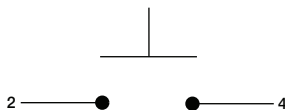
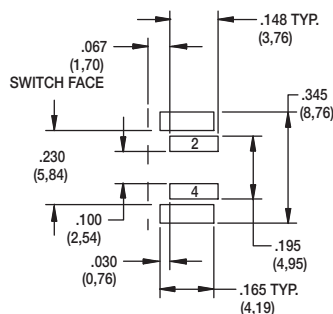

SCHEMATIC

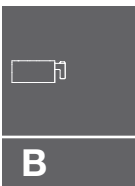

Dimensions are shown: mm
Specifications and dimensions subject to change

KT Series Full SMT Top & Side Actuated Sealed Tact Switch

BUTTON

BUTTON

To order buttons in bulk

02 PRESS FIT

| PART NUMBER | Internal Part Number | Button Color |
|-----------------------|----------------------|-----------------|
| BTN KT11 02 80 | 5081 01000 | Ivory (Natural) |
| BTN KT11 02 90 | 5081 02000 | Black |
| BTN KT11 02 40 | 5081 03000 | Red |

Materials: Nylon
Finish: Gloss

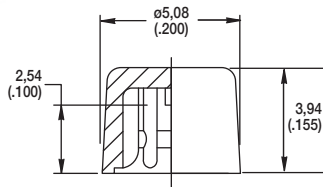

03 SNAP FIT, HIGH TEMPERATURE

| PART NUMBER | Internal Part Number | Button Color |
|-----------------------|----------------------|-----------------|
| BTN KT11 03 80 | 685B 01000 | Ivory (Natural) |
| BTN KT11 03 90 | 685B 02000 | Black |

Materials: Nylon
Finish: Gloss

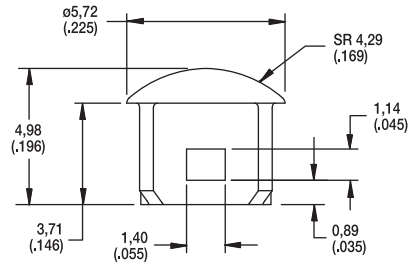

K5AT Illuminated SMT Tact Switch

Features

- High bright LED's
- Gold plated dome contact offering superior contact reliability in time
- Excellent ergonomics: sharp tactile feel and audible click
- Reduced space usage on board "2 in 1"
- 40 N overload
- Tape and reel
- RoHS compliant and compatible

Typical Applications

- Application requiring illumination
- Server, storage
- Network infrastructure
- Telecom
- Medical



B

Tactile Switches

Specification

FUNCTION: momentary action
 CONTACT ARRANGEMENT: Normally Open
 TERMINALS: SMT with positioning pegs;
 SMT without positioning pegs is available, contact Customer Service

Mechanical

| Type | Operating force FA ¹ Newtons (grams) | Operating life (operations) | Travel (total travel) mm(mm) |
|--------------|---|--------------------------------|---------------------------------|
| K5AT WH 43GP | 4.0 (400) | 100,000 | 0,5 (0.8) |

¹ Tolerances of operating force FA is ± 25%.

Packaging

Standard: 900 pcs per reel; Reel diameter 380 mm
 Reduced: 180 pcs per reel; Reel diameter 180 mm

Electrical

POWER MIN/MAX: 0.02VA / 1.0VA
 VOLTAGE MIN/MAX: 20mVdc – 32 Vdc
 CURRENT MIN/MAX: 0.1mA – 100mA
 CONTACT RESISTANCE: <100m Ω
 INSULATION RESISTANCE: >1G Ω initial, >10M Ω after damp heat
 BOUNCE TIME: <10ms

Environmental

OPERATING TEMPERATURE: -40°C to 125°C
 STORAGE TEMPERATURE: -55°C to 125°C
 RELATIVE HUMIDITY: 90 to 96% according to NF EN 60068-2-30
 PROTECTION: dust protection and flux tight (IP 40)
 OVERLOAD: 40N min

Process

SOLDERING: Compatible with the lead free soldering profile.
 No washing

Materials

CONTACTS: Au over Ni
 SOLDERING: Au over Ni
 HOUSING: Thermoplastic UL94 V0

How To Order

Our easy build-a-switch concept allows you to mix and match options to create the switch you need. To order, select desired option from each category and place it in the appropriate box.

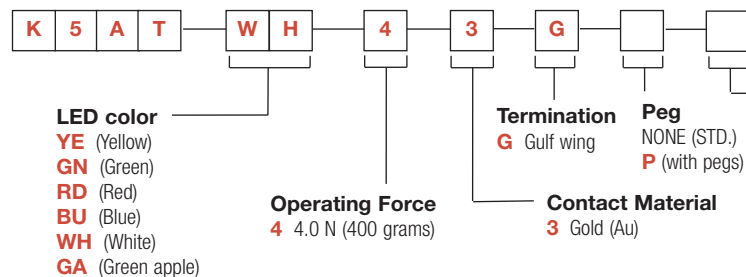

Packaging

NONE (900 pieces per reel)
 R (reduced packaging 180 pieces per reel)

K5AT Illuminated SMT Tact Switch

K5AT

Tactile Switches

B

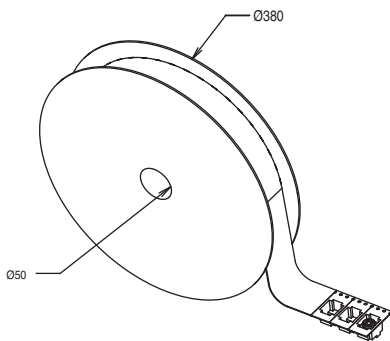
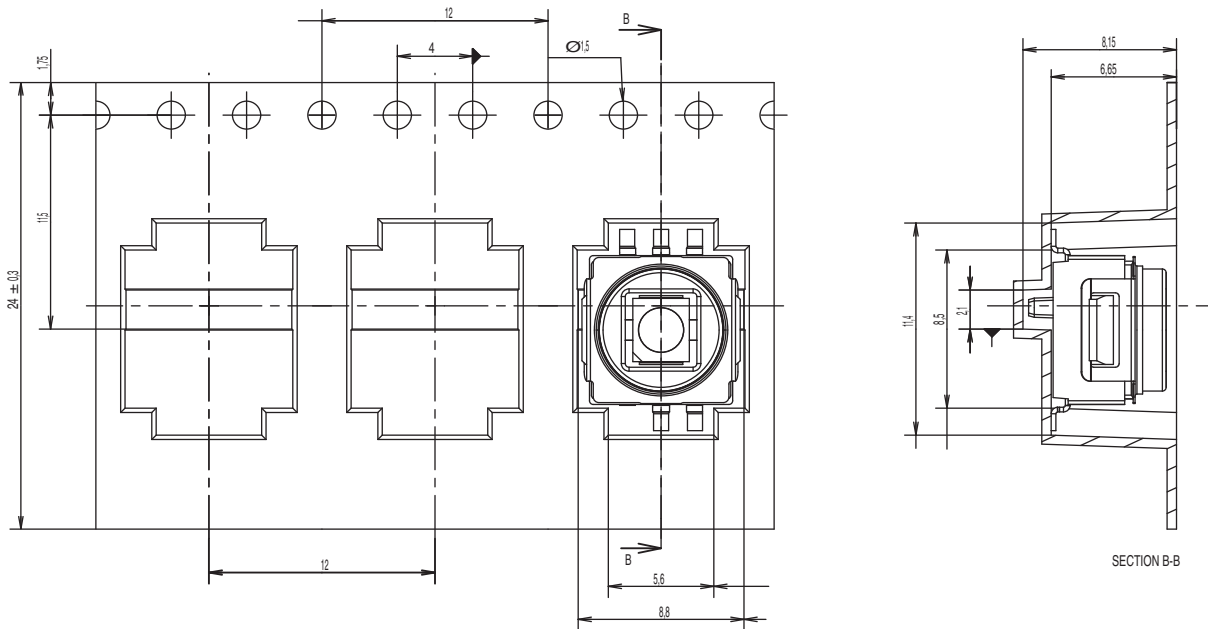
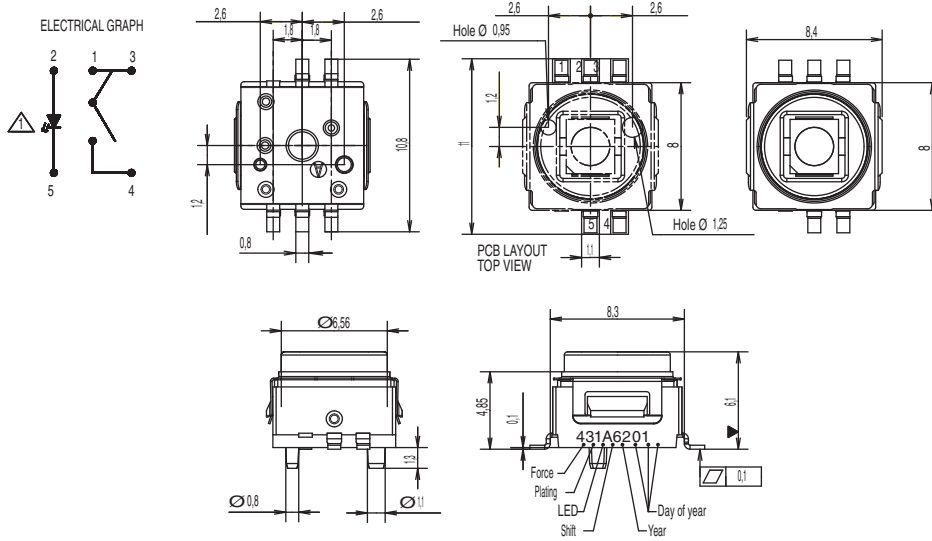

Dimensions are shown: mm
Specifications and dimensions subject to change



Lighted SMT Tact Switch with Rugged LED Mounting Process

Features

- LED assembly without soldering
- Various LED options
- No light perturbation
- Sound haptic
- Various climatic classes

Typical Applications

- Automotive
- Network equipment
- Telecommunications
- Medical equipment
- Industrial controls



B

Tactile Switches

Specification

FUNCTION: momentary action
 CONTACT ARRANGEMENT: 1 make control = SPST, N.O.
 TERMINALS: Gullwing type for SMT, peg as option, 2 terminals for LED

Mechanical

| Type | Actuation Force (N) | Operating Life (operations) | Total Travel (mm) |
|-------------|---------------------|-----------------------------|-------------------|
| K8xx41G LFS | 4.0 | 300,000 | 0.45±0.15 |

Tolerances on actuation force is ± 0.25%.
 SEALING LEVEL: IP40

Illumination Colors

White, blue, pure green, orange, super red
 LED technical information available on product specification.
 For any extra color, please contact your sales representative.

Packaging

In reels of 900 pieces under sealed foil.
 Dimensions of reels according to EIA RS481 or IEC 2863.
 External diameter 380 mm.

Electrical

| | Silver | Gold |
|---|---------------------|--------|
| MAXIMUM POWER: | 1.0 VA | 0.2 VA |
| MAXIMUM VOLTAGE: | 32 VDC | 32 VDC |
| MINIMUM VOLTAGE: | 20 mV | 20 mV |
| MAXIMUM CURRENT: | 50 mA | 10 mA |
| MINIMUM CURRENT: | 1 mA | 0.1 mA |
| DIELECTRIC STRENGTH: (50 Hz, 1 min.) | ≥ 250 Vrms | |
| CONTACT RESISTANCE: | < 100mΩ | |
| INSULATION RESISTANCE: (100 V, initial stage) | > 10 ⁹ Ω | |
| BOUNCE TIME: | < 10 ms | |

Environmental

OPERATING TEMPERATURE: -40°C to +85°C (Silver)
 -40°C to +125°C (Gold)

STORAGE TEMPERATURE: -55°C to +85°C (Silver)
 -40°C to +125°C (Gold)

Process

SOLDERING: Compatible with the lead free soldering profile.
 No washing
 MSL level: 5

NOTE:

The specifications show in the datasheet are for reference only and are not valid for design-in work. Please contact your sales representative to request drawings and product specifications.

For systems where reliability and safety are required, please contact your sales representative to secure product integration and function to secure usage.

How To Order

Our easy build-a-switch concept allows you to mix and match options to create the switch you need. To order, select desired option from each category and and place it in the appropriate box.

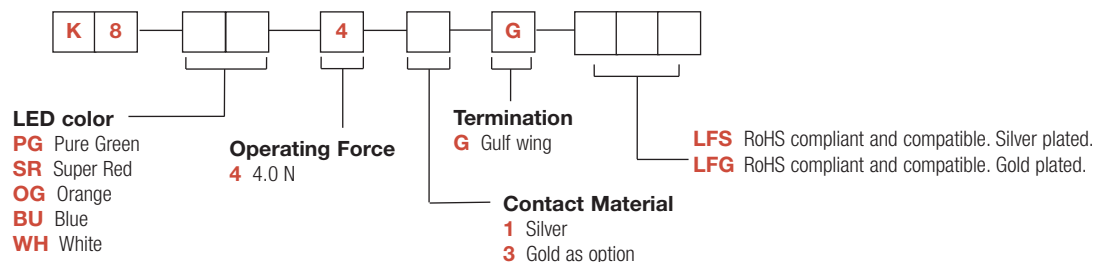

Dimensions are shown: mm
 Specifications and dimensions subject to change

K8 Lighted SMT Tact Switch with Rugged LED Mounting Process

| PART NUMBER | REF LED | EMITTED COLOR | LUMINOUS INTENSITY (mcd) $I_f = 20 \text{ mA}$ | | CHROMATICITY COORDINATES OR PEAK WAVE LENGTH (typ) $I_f = 20 \text{ mA}$ | | FORWARD VOLTAGE V $I_f = 20 \text{ MA}$ | |
|-------------|-------------------|---------------|--|-----|--|------|---|------|
| | | | min | typ | X | Y | min | max |
| K8WH41G | LW T67C-S2U1-5K8L | WHITE | 224 | 560 | 0,33 | 0,33 | 3 | 4.1 |
| K8BU41G | LB T67C-P2R1-35 | BLUE | 56 | 140 | 465 nm | | 3 | 4.1 |
| K8PG41G | LP T676-L1M2-25 | PURE GREEN | 11.2 | 28 | 562 nm | | 1.8 | 2.4 |
| K8SR41G | LP T676-Q1R2-1 | SUPER RED | 71 | 180 | 645 nm | | 1.8 | 2.3 |
| K8OG41G | LO T676-R1S2-24 | ORANGE | 112 | 280 | 610 nm | | 1.85 | 2.35 |

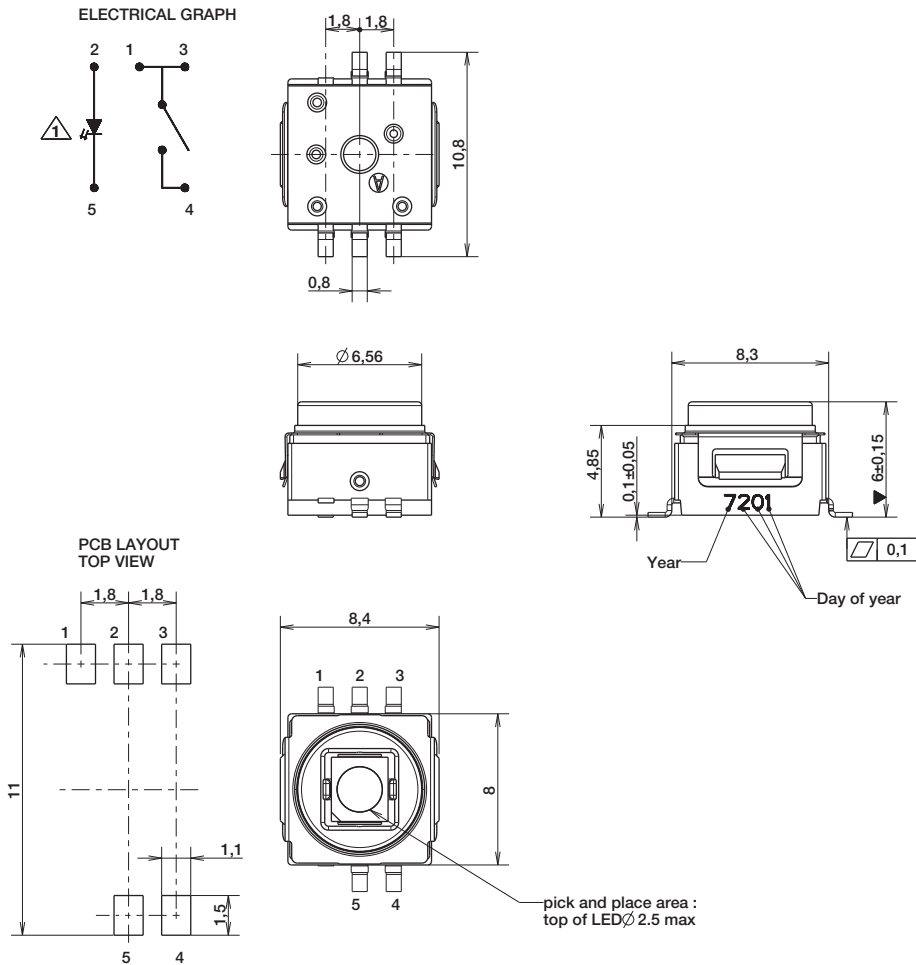

Dimensions are shown: mm
Specifications and dimensions subject to change



Lighted SMT Tact Switch with Rugged LED Mounting Process

TAPE & REEL

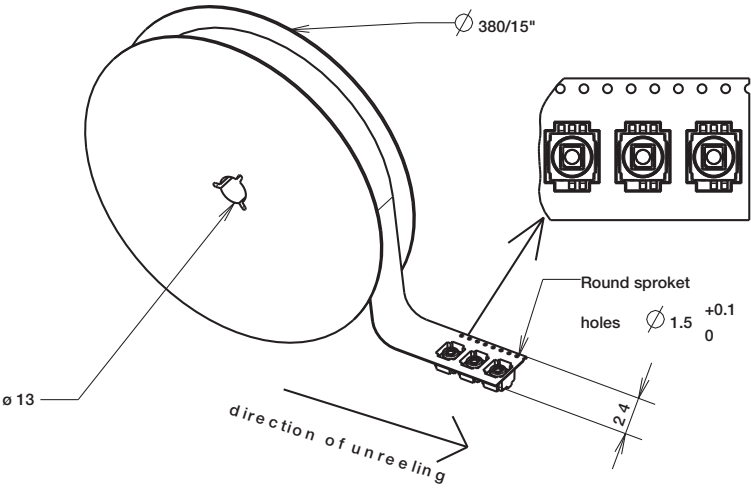

Tactile Switches

K5V Illuminated Tact Switch



Features

- Gold plated dome contact SPST/SPDT
- Excellent ergonomics
- High bright leds
- Reduced space usage on board
- 40 N overload
- Tape and reel
- RoHS compliant and compatible

Typical Applications

- When backlighting and switch are required to be a "2 in 1" component
- The dome contact secures a superior contact reliability in time
- The ergonomics of K5V provides a long travel, a sharp tactile feel and an audible click
- Server, storage, automotive, network infrastructure, medical

Specification

FUNCTION: momentary action
 CONTACT ARRANGEMENT: Normally Open + Normally Closed
 TERMINALS:
 THT: Through hole terminals with positioning pegs
 SMT: Surface mount terminals with positioning pegs
 PM: Panel mount solder terminals with wire hole

Electrical

POWER MIN/MAX: 0.02VA / 1.0VA
 VOLTAGE MIN/MAX: 20mVdc – 32 Vdc
 CURRENT MIN/MAX: 0.1mA – 100mA
 CONTACT RESISTANCE: <150m Ω
 INSULATION RESISTANCE: >1G Ω initial, >10M Ω after damp heat
 BOUNCE TIME: <5ms

Mechanical

| Version | Operating force FA ¹ Newtons (grams) | Operating life (operations) | Travel (total travel) mm(mm) |
|--------------|---|-----------------------------------|------------------------------------|
| THT, SMT, PM | 4.0 (400) | 25,000 | 1.2 (2.4) |

¹ Tolerances of operating force FA is ± 25%.

Environmental

OPERATING TEMPERATURE: -40°C to 85°C
 STORAGE TEMPERATURE: -50°C to 85°C
 RELATIVE HUMIDITY: 90 to 96% according to NF EN 60068-2-30
 PROTECTION: dust protection and flux tight
 OVERLOAD: 40N min

Packaging

THT:
 60 pieces per tray; 1800 pieces per box
 SMT:
 330 pieces per reel (reel ø 360mm); 1320 pieces per box
 PM:
 60 pieces per tray; 2100 pieces per box

Process

SMT
 Soldering: Compatible with the lead free soldering profile
 No washing
 THT
 Soldering: Compatible with the lead free soldering profile
 No washing
 PM
 Soldering: Low wattage soldering iron (25-50 watts max).
 Solder time 3 seconds max. No washing

Materials

LEAD FREE
 CONTACTS: Au over Ni
 SOLDERING: Au over Ni
 HOUSING: Thermoplastic UL94 V0

How To Order

Our easy build-a-switch concept allows you to mix and match options to create the switch you need. To order, select desired option from each category and place it in the appropriate box.

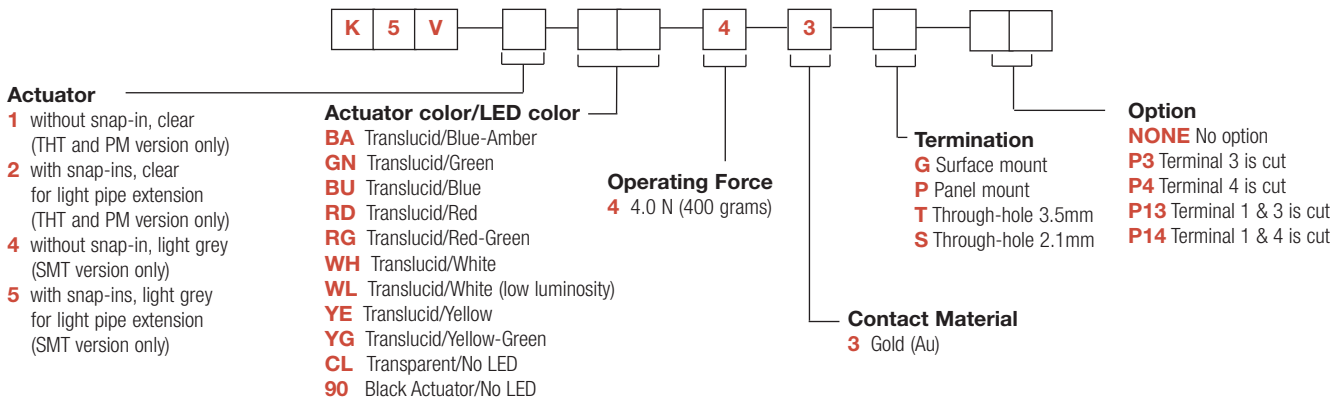

K5V Illuminated Tact Switch

K5V SMT

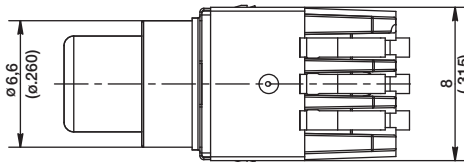
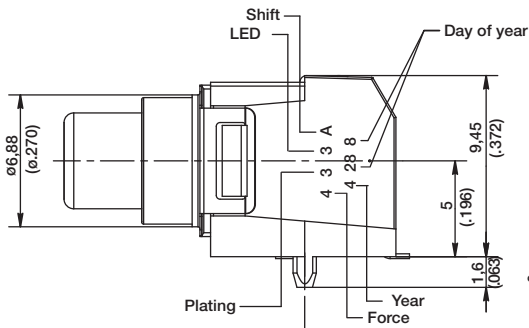
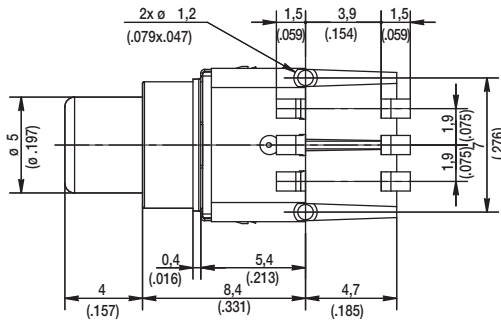

ELECTRICAL DIAGRAM

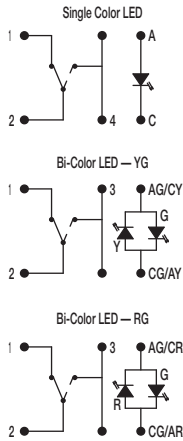

RECOMMENDED PCB LAYOUT (WITH HOLES)

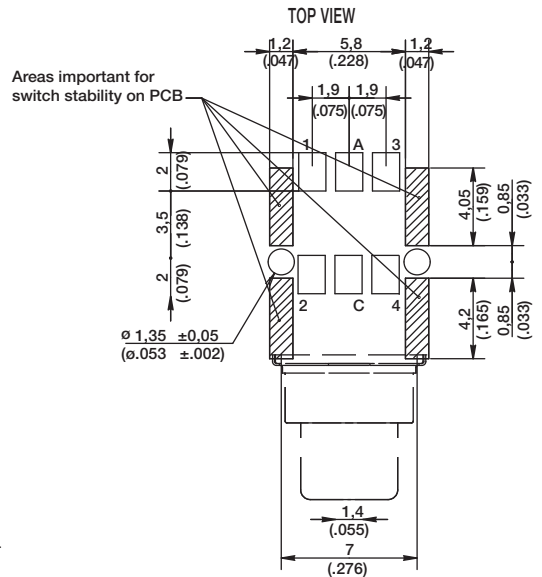

TAPE & REEL

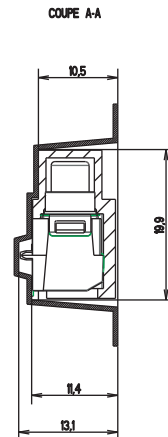
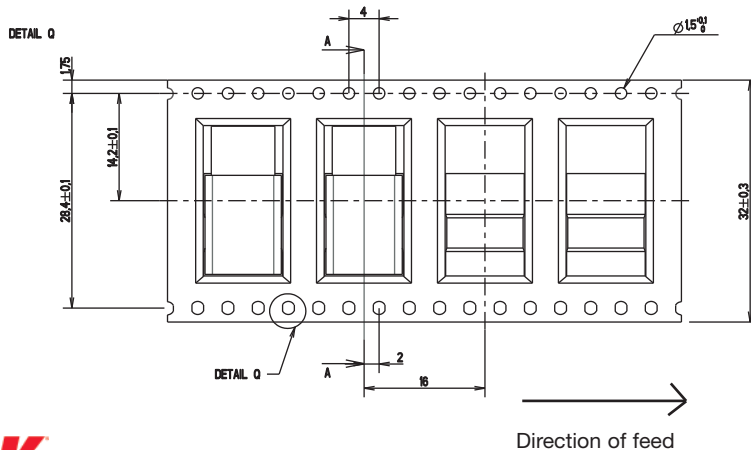
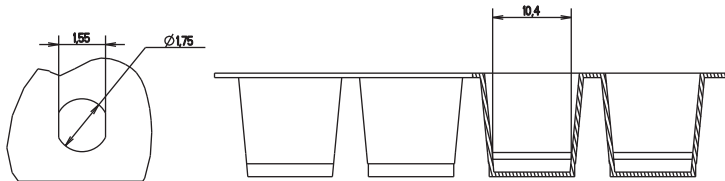

Dimensions are shown: mm
Specifications and dimensions subject to change



K5V Illuminated Tact Switch

B

Tactile Switches

K5V THT

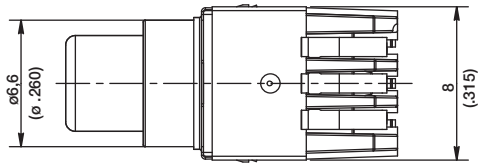
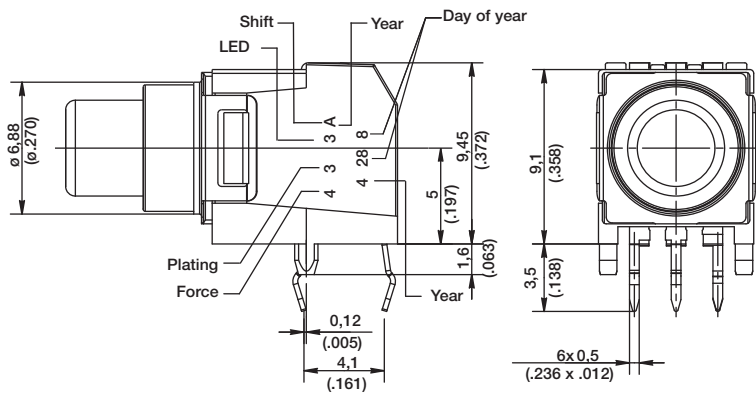
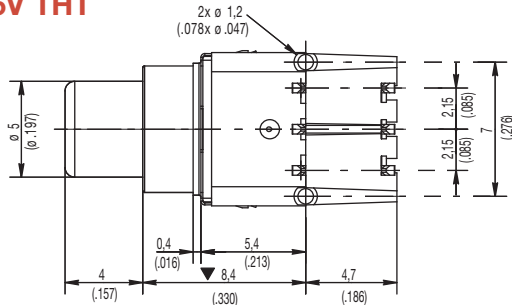

ELECTRICAL DIAGRAM

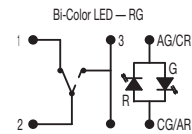
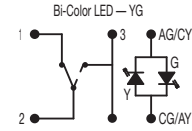
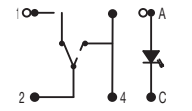

RECOMMENDED PCB LAYOUT (WITH HOLES) TOP VIEW

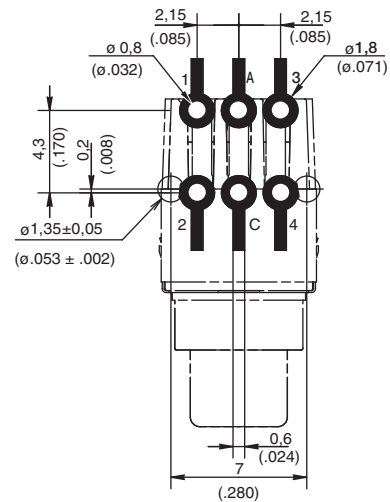

TRAY

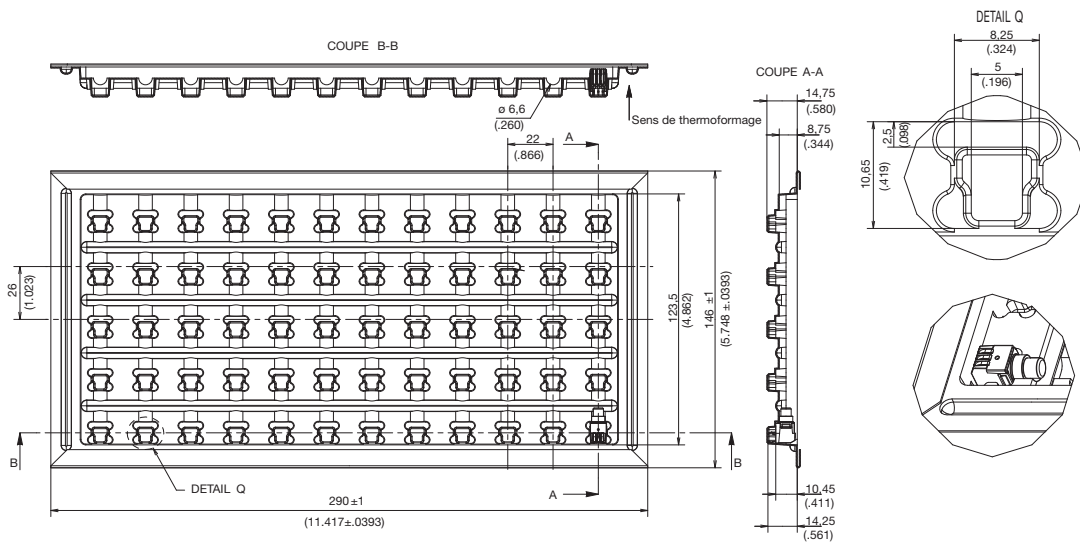

Dimensions are shown: mm
Specifications and dimensions subject to change

K5V Illuminated Tact Switch

K5V PM

PRODUCT IDENTIFICATION AND DATE CODES

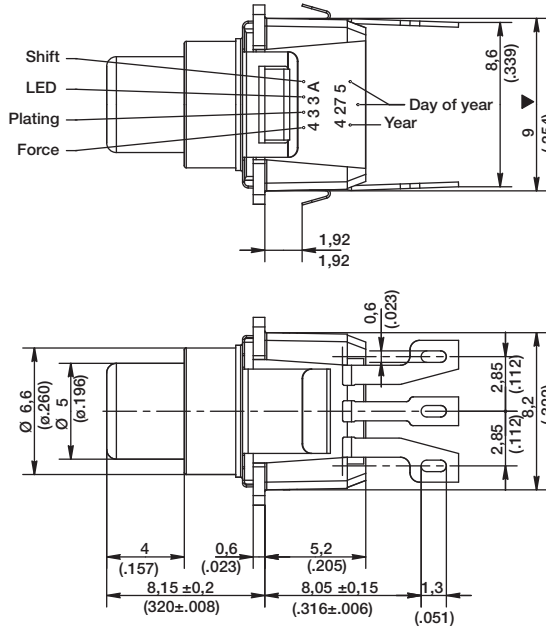

ELECTRICAL DIAGRAM

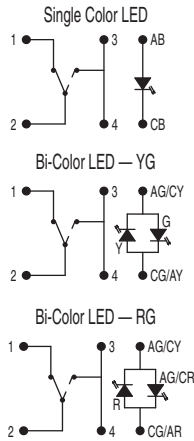

TERMINAL REFERENCES

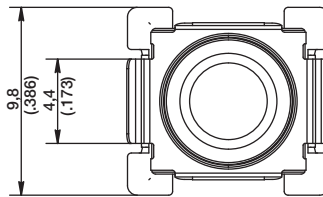
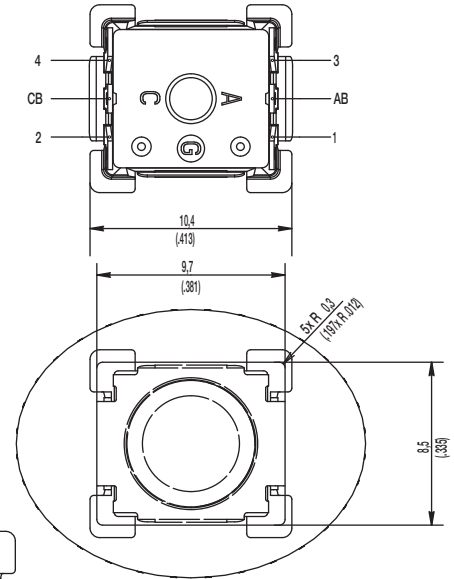

B

Tactile Switches

TRAY

SUITABLE FOR PANEL THICKNESS OF 1.8MM MAX

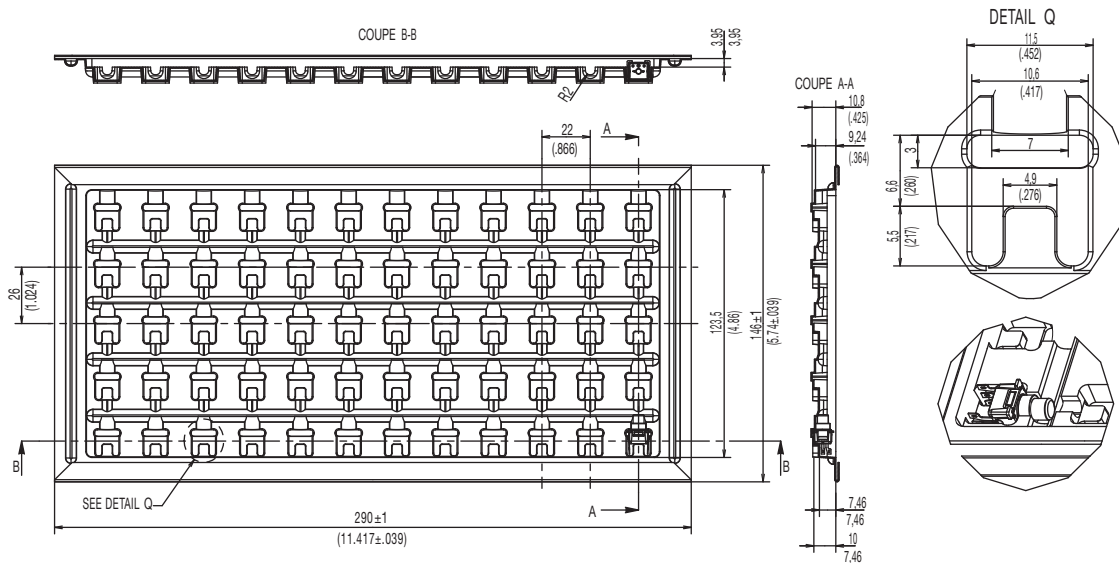

Dimensions are shown: mm
Specifications and dimensions subject to change

KSF & KSFI Series Soft Actuated Tact Switch



Features/Benefits

- Soft actuated switch
- Sealed front end
- Top and side actuated

Typical Applications

- Low profile keyboards
- Automotive interfaces
- Industrial control

B

Tactile Switches

Specification

FUNCTION: momentary action
CONTACT ARRANGEMENT: 1 make contact = SPST, N.O.
TERMINALS: THT pins

Mechanical

| Type | Force (N) | Operating life (operations) | Travel (mm) |
|--------------------|------------|-----------------------------|-------------|
| KSF0M211LFTR | 1.5 ± 0.5 | 100,000 | 0.25 ± 0.1 |
| KSF0M311LFTR | 1.9 ± 0.5 | 100,000 | 0.25 ± 0.1 |
| KSF0M411LFTR | 3.0 ± 0.75 | 100,000 | 0.25 ± 0.1 |
| KSF0M511LFTR | 5.2 ± 1.0 | 100,000 | 0.25 ± 0.1 |
| KSFI0V91170SH LFTR | 3.4 ± 1.5 | 100,000 | 0.65 ± 0.25 |
| KSF0M212 LFT | 1.6 ± 0.4 | 300,000 | 0.25 ± 0.1 |
| KSFI0M412 70SHLFT | 3.2 ± 0.8 | 100,000 | 0.75 ± 0.25 |

Overload resistance: 40N, 1 time
Sealing: IP60 or IP67

NOTE: Other configurations of haptics and terminals are available upon demand. Please also refer to KSF and KSFI Mk2 catalogues pages for other options.

This product is designed and manufactured for general electronic devices. For systems where reliability and safety are required, please contact your sales representative to secure product integration and function to secure usage.

Electrical

| | Silver | Gold |
|---|--------|--------|
| MAXIMUM POWER: | 1 VA | 0.2 VA |
| MAXIMUM VOLTAGE: | 32 VDC | 32 VDC |
| MINIMUM VOLTAGE: | 20 mV | 20 mV |
| MAXIMUM CURRENT: | 50 mA | 10 mA |
| MINIMUM CURRENT: | 1 mA | 1 mA |
| DIELECTRIC STRENGTH (50 Hz, 1 min.): > 250 Vrms | | |
| CONTACT RESISTANCE: < 100 m Ω | | |
| INSULATION RESISTANCE (100 V, initial stage): > 10 ⁹ Ω | | |
| BOUNCE TIME: < 1 ms | | |

Environmental

| | Silver | Gold |
|------------------------|---------------|----------------|
| OPERATING TEMPERATURE: | -40°C to 85°C | -40°C to 125°C |
| STORAGE TEMPERATURE: | -55°C to 85°C | -40°C to 125°C |

Process

SOLDERING

Packaging

In boxes of 250 pieces (V type) or 500 pieces (M type).

How To Order

Our easy build-a-switch concept allows you to mix and match options to create the switch you need. To order, select desired option from each category and place it in the appropriate box.

However, please note that all the combinations of these options are not feasible.

For any part number different from those listed above, please consult your local representative.

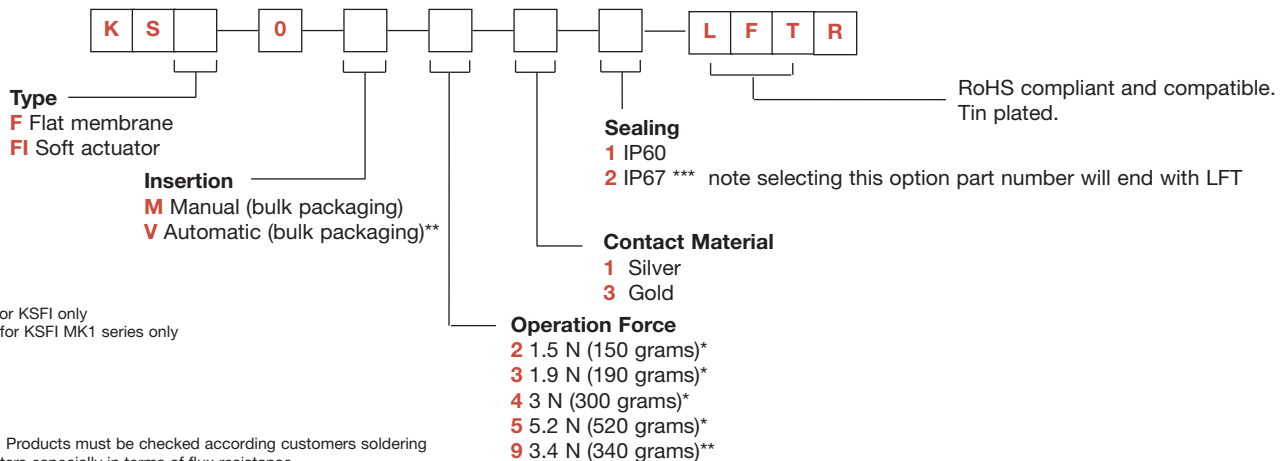

* valid for KSFI only
** valid for KSFI MK1 series only

***NOTE:** Products must be checked according customers soldering parameters especially in terms of flux resistance.

KSF & KSFI Series Soft Actuated Tact Switch

KSF

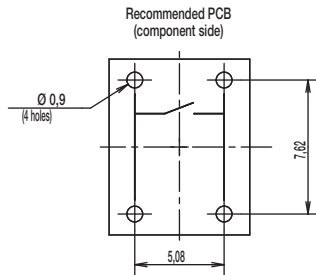
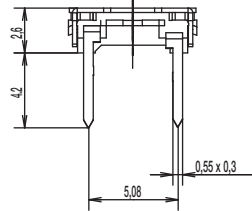
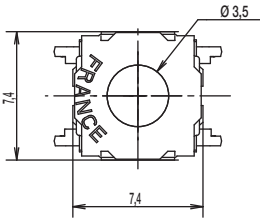
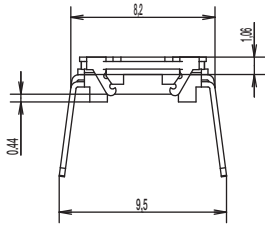

KSFI 0V

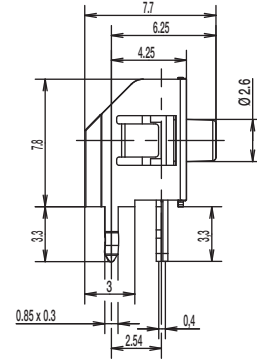
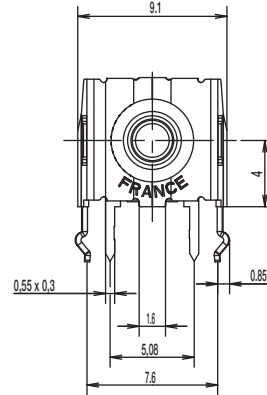

B

Tactile Switches

KSA & KSL Series Sealed Tact Switch



Features/Benefits

- Designed for automatic or manual insertion
- Cambered terminals to ensure self retention
- Top or side actuated
- Large choice of caps
- RoHS compliant and compatible

Typical Applications

- Automotive
- Industrial
- Telecommunication networks

B

Tactile Switches

Specification

CONTACT ARRANGEMENT: SPST, N.O.
 DOUBLE OVERMOLDING ON TERMINAL
 SEALING: IP60
 TERMINALS: PC pins, ground pin optional

Mechanical

| Type | Actuation force N | Operating life (operations) | Travel to make |
|----------|-------------------|-----------------------------|----------------|
| KSA0M211 | 1,4 ± 0,4 | 100,000 | 0,5 ± 0,2 |
| KSA0M311 | 1,4 ± 0,4 | 1,000,000 | 0,5 ± 0,2 |
| KSA0M411 | 3 ± 0,75 | 100,000 | 0,6 ± 0,2 |
| KSA0M511 | 5 ± 1,5 | 100,000 | 0,7 ± 0,2 |
| KSA0M911 | 3 ± 0,75 | 500,000 | 0,6 ± 0,2 |
| KSL0M211 | 1,4 ± 0,4 | 100,000 | 0,5 ± 0,2 |
| KSL0M311 | 1,4 ± 0,4 | 1,000,000 | 0,5 ± 0,2 |
| KSL0M411 | 3 ± 0,75 | 100,000 | 0,6 ± 0,2 |
| KSL0M511 | 5 ± 1,5 | 100,000 | 0,7 ± 0,2 |
| KSL0M911 | 3 ± 0,75 | 500,000 | 0,6 ± 0,2 |

NOTE: Other versions in terms of force, termination length and corrosion protection available. Please contact your sales representative.
 This data sheet does not provide enough information for applications which require a certain level of quality or safety such as automotive, medical systems, safety equipment. Please contact your sales representative to get contractual specification package.

Electrical

| | Silver | Gold |
|--|--------|--------|
| MAXIMUM POWER: | 1 VA | 0.2 VA |
| MAXIMUM VOLTAGE: | 32 VDC | 32 VDC |
| MINIMUM VOLTAGE: | 20 mV | 20 mV |
| MAXIMUM CURRENT: | 50 mA | 10 mA |
| MINIMUM CURRENT: | 1 mA | 1 mA |
| DIELECTRIC STRENGTH: 250 Vrms | | |
| CONTACT RESISTANCE: ≤ 100m Ω | | |
| INSULATION RESISTANCE (100 V): ≥ 10 ⁹ Ω | | |
| BOUNCE TIME: ≤ 1 ms | | |

Environmental

| | Silver | Gold |
|------------------------|---------------|----------------|
| OPERATING TEMPERATURE: | -40°C to 85°C | -40°C to 125°C |
| STORAGE TEMPERATURE: | -40°C to 85°C | -55°C to 125°C |

Process

Wave soldering compatible with lead free soldering profile.

Packaging

Can be delivered in tubes of 65 pieces for automatic insertion or in boxes of 500 pieces for manual insertion (250 pieces for KSL, KSLV, KSAV).

How To Order

Our easy build-a-switch concept allows you to mix and match options to create the switch you need. To order, select desired option from each category and place it in the appropriate box.

However, please note that all the combinations of these options are not feasible.

For any part number different from those listed above, please consult your local representative.

SWITCH

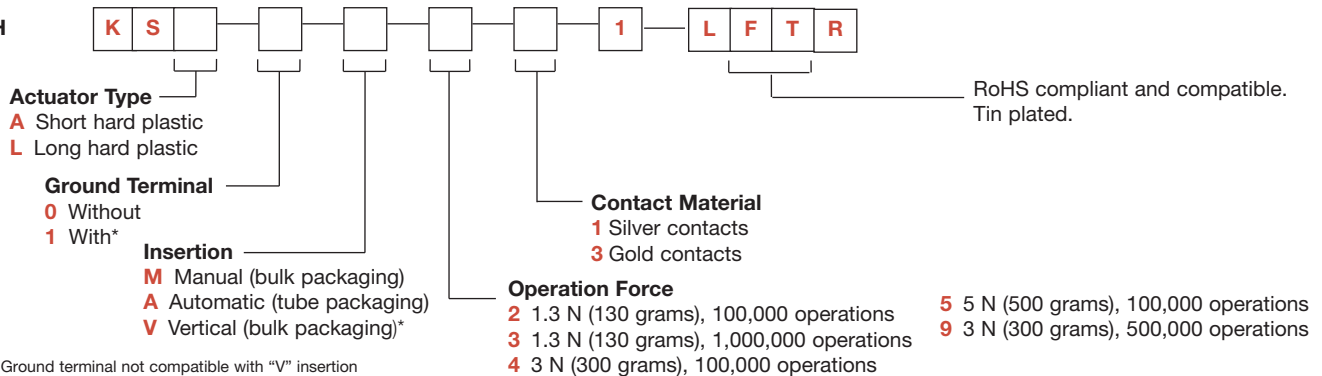

BUTTONS Buttons must be ordered separately and will be supplied in bulk.

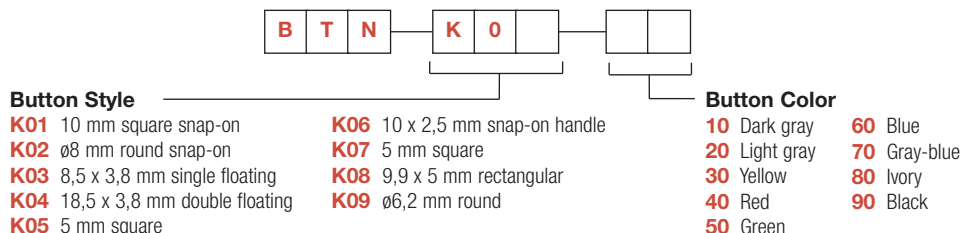

*NOTE: Please note that all buttons are not RoHS compliant. Please check the compliance with your C&K sales representative.



KSA & KSL Series Sealed Tact Switch

ACTUATOR TYPE

KSA & KSL

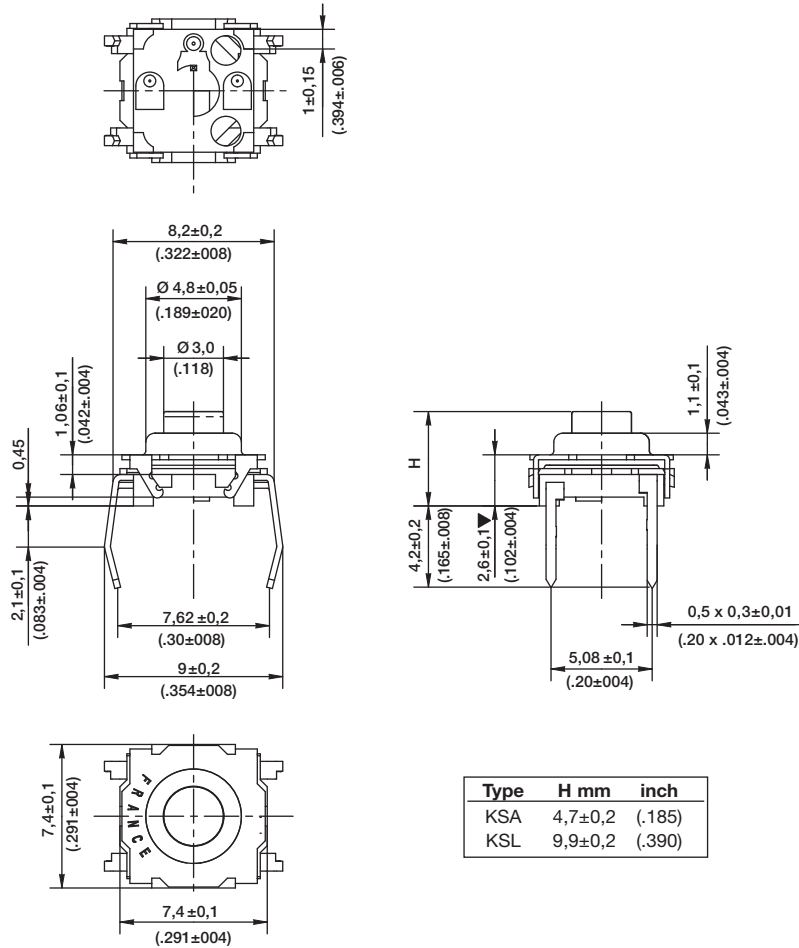

B

Tactile Switches

GROUND TERMINAL

0 WITHOUT

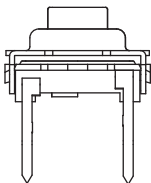

1* WITH

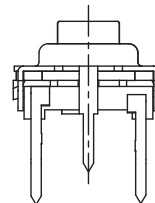

*Not compatible with "V" insertion



Dimensions are shown: mm
Specifications and dimensions subject to change



26 jul 16

KSA & KSL Series Sealed Tact Switch

INSERTION

Tactile Switches

M MANUAL (BULK PACKAGING)

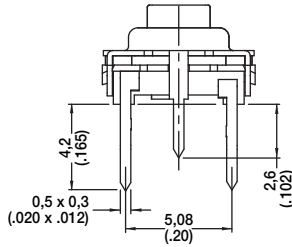
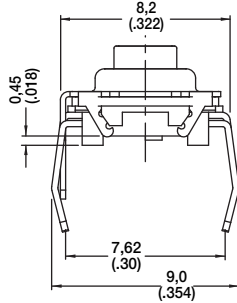

PCB LAYOUT

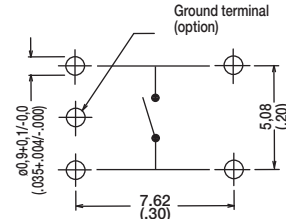

A AUTOMATIC (TUBE PACKAGING, 65 PIECES PER TUBE)

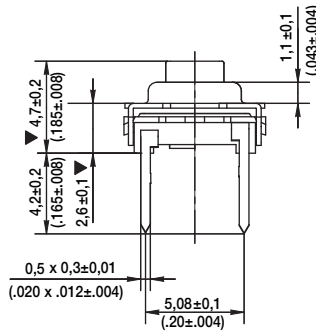
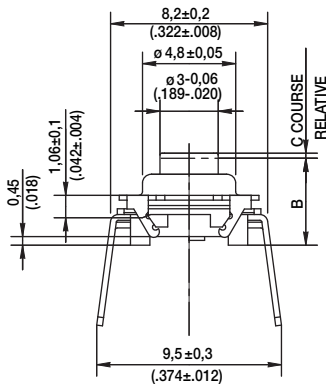

PCB LAYOUT

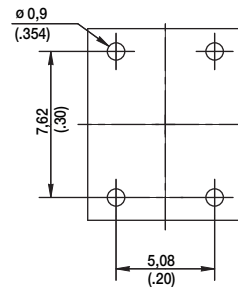

V VERTICAL

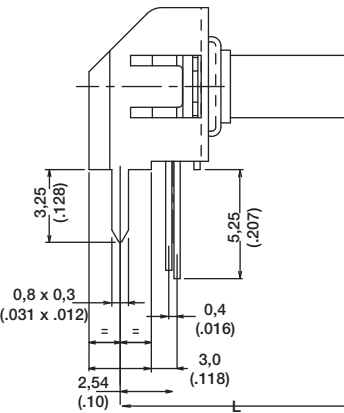
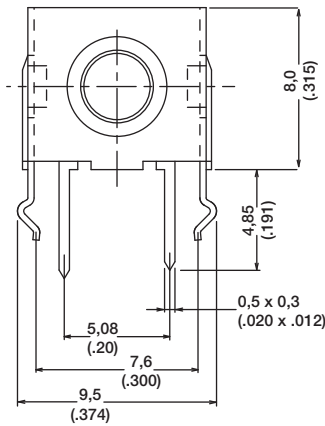

PCB LAYOUT

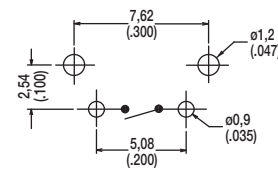

DIMENSION L

| Type | L mm | inch |
|-------|------|------|
| KSA0V | 5,8 | .228 |
| KSL0V | 11,1 | .437 |

OPERATING FORCE

| OPTION CODE | OPERATING FORCE |
|-------------|---|
| 2 | 1.3 N (130 grams) 100,000 operations |
| 3 | 1.3 N (130 grams) 1,000,000 operations |
| 4 | 3.0 N (300 grams) 100,000 operations |
| 5 | 5.0 N (500 grams) 100,000 operations |
| 9 | 3.0 N (300 grams) 500,000 operations |



First Angle
Projection

Dimensions are shown: mm
Specifications and dimensions subject to change



KSA & KSL Series Sealed Tact Switch

CONTACT MATERIAL

| OPTION CODE | CONTACT MATERIAL |
|-------------|------------------|
| 1 | Silver contacts |
| 3 | Gold contacts |

SEALING

| OPTION CODE | SEALING |
|-------------|--------------------|
| 1 | Sealing level IP60 |

BUTTONS

Buttons must be ordered separately and will be supplied in bulk.

| BUTTON TYPE | KSA | KSL | KSAV | KSLV |
|-------------|-----|-----|------|------|
| K01 | X | | | |
| K02 | X | | | |
| K03 | X | X | X | X |
| K04 | X | X | X | X |
| K05 | | X | | X |
| K06 | X | | | |
| K07 | | X | | X |
| K08 | | X | | X |
| K09 | | X | | X |

K01

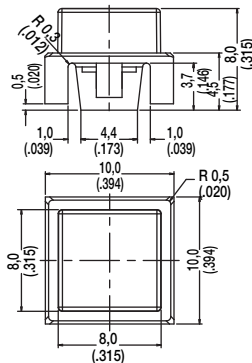
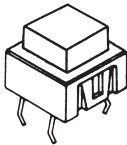

K02

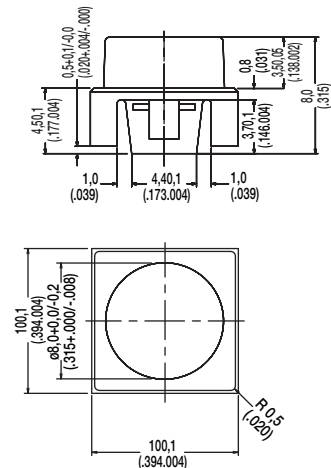
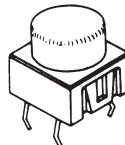

Dimensions are shown: mm
Specifications and dimensions subject to change

KSA & KSL Series Sealed Tact Switch

Tactile Switches

B

K03

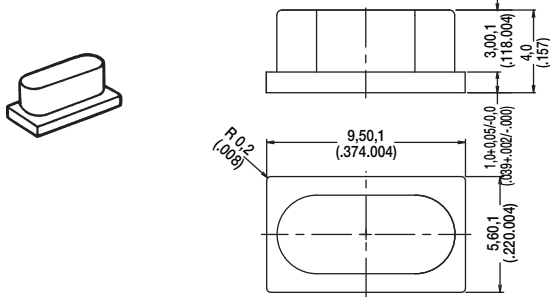

K04

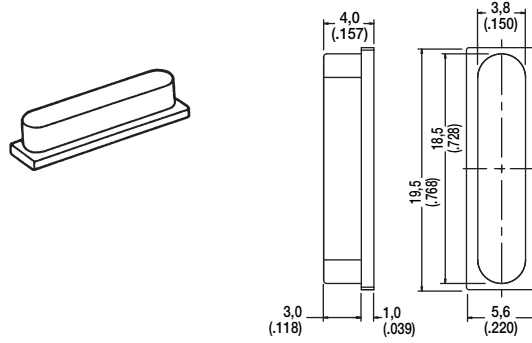

K05

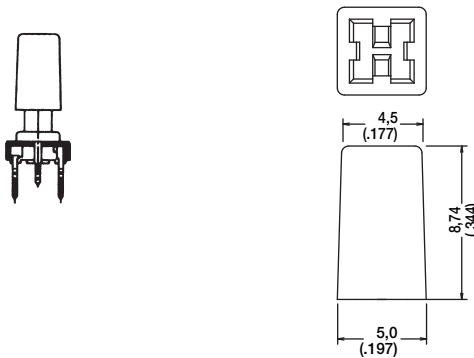

K06

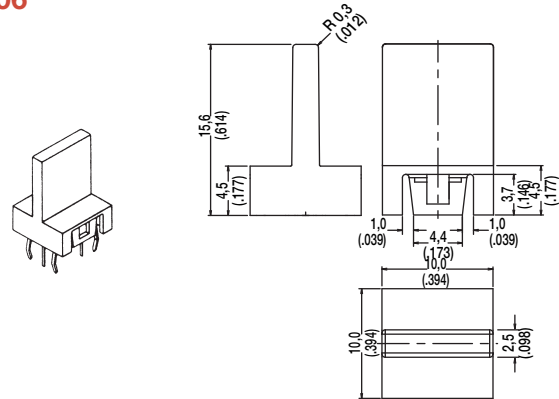

K07

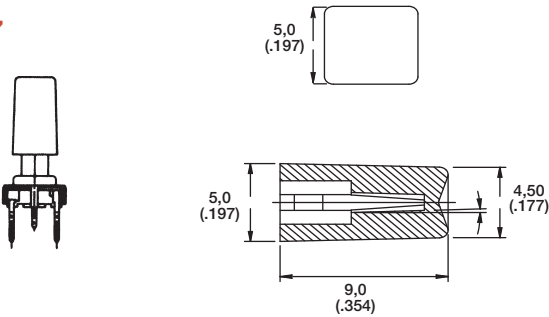

K08

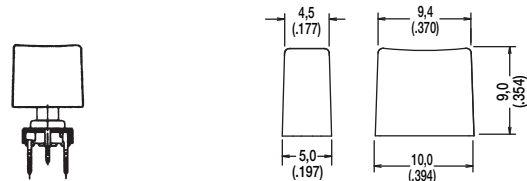

K09

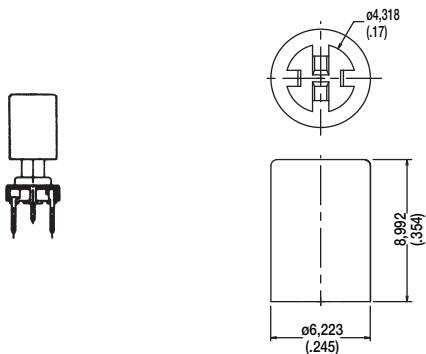

First Angle
Projection

Dimensions are shown: mm
Specifications and dimensions subject to change

KSA & KSL MKII Series High Performance Sealed Tact Switch

Features/Benefits

- Highest tact switch sealing performance
- Improved sealing through a modification of the crimping technique and to a double overmolding of the terminal
- Totally sealed
- Up to 1M operations
- RoHS compliant and compatible

Typical Applications

- Automotive
- Industrial
- Telecommunication networks
- Household appliances
- Heating control systems



B

Tactile Switches

Specification

CONTACT ARRANGEMENT: SPST, N.O.
TERMINALS: PC pins
SEALING: IP65
Double overmold on terminals

Mechanical

| Type | Actuation force N (grams) | Operating life (operations) | Travel to make |
|----------|------------------------------|--------------------------------|-------------------|
| KSA0M212 | 1,3 ± 0,3 | 100,000 | 0,5 ± 0,15 |
| KSA0M312 | 1,3 ± 0,3 | 1,000,000 | 0,5 ± 0,15 |
| KSA0M412 | 3,25 ± 0,5 | 100,000 | 0,6 ± 0,25 |
| KSA0M512 | 5 ± 1,25 | 100,000 | 0,7 ± 0,25 |

Packaging

Delivered in boxes of 500 pieces (250 pieces for KSL)

NOTE: Specifications listed above are for switches with standard options.
For information on specific and custom switches, consult Customer Service Center.

Other versions in terms of force, termination length and corrosion protection available.
Please contact your sales representative.

This data sheet does not provide enough information for applications which require a certain level of quality or safety such as automotive, medical systems, safety equipment.
Please contact your sales representative to get contractual specification package.

Electrical

| | Silver | Gold |
|--------------------------------|---------------------|--------|
| MAXIMUM POWER: | 1 VA | 0.2 VA |
| MAXIMUM VOLTAGE: | 32 VDC | 32 VDC |
| MINIMUM VOLTAGE: | 20 mV | 20 mV |
| MAXIMUM CURRENT: | 50 mA | 10 mA |
| MINIMUM CURRENT: | 1 mA | 1 mA |
| DIELECTRIC STRENGTH: | ≥ 250 Vrms | |
| CONTACT RESISTANCE: | ≤ 100m Ω | |
| INSULATION RESISTANCE (100 V): | ≥ 10 ⁹ Ω | |
| BOUNCE TIME: | ≤ 1 ms | |

Environmental

| | Silver | Gold |
|------------------------|---------------|----------------|
| OPERATING TEMPERATURE: | -40°C to 85°C | -40°C to 125°C |
| STORAGE TEMPERATURE: | -40°C to 85°C | -55°C to 125°C |

Process

Wave soldering compatible with lead free soldering profile.

How To Order

Our easy build-a-switch concept allows you to mix and match options to create the switch you need. To order, select desired option from each category and place it in the appropriate box.

However, please note that all the combinations of these options are not feasible.

For any part number different from those listed above, please consult your local representative.

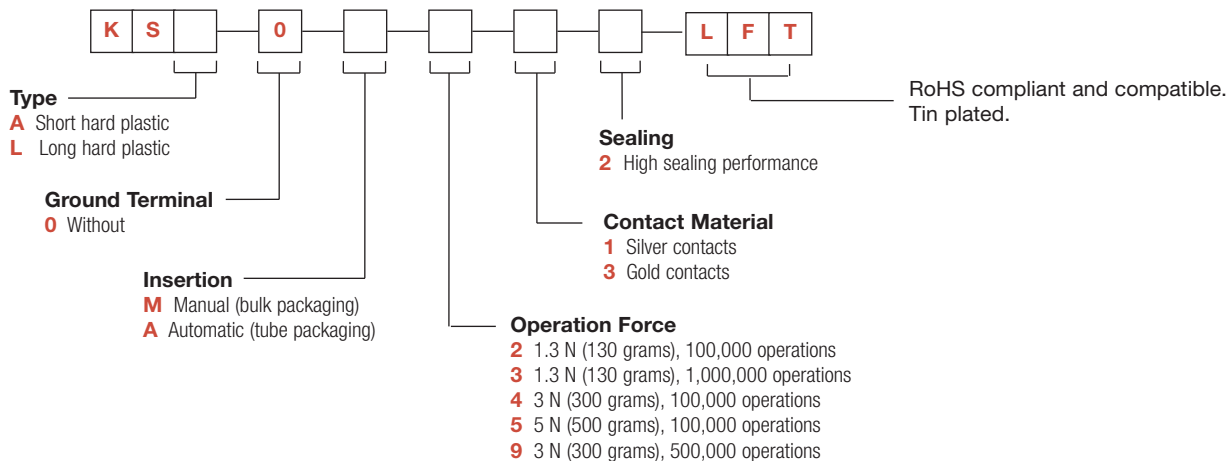

KSA & KSL MKII Series High Performance Sealed Tact Switch

TYPE 

KSA & KSL

MANUAL INSERTION

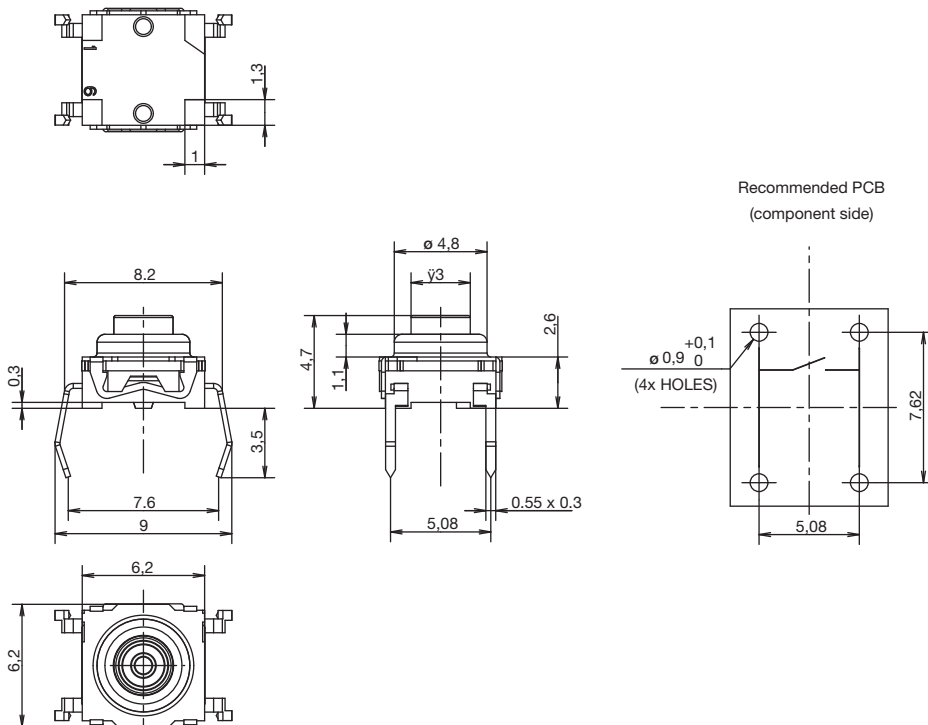

KSA & KSL

AUTOMATIC INSERTION

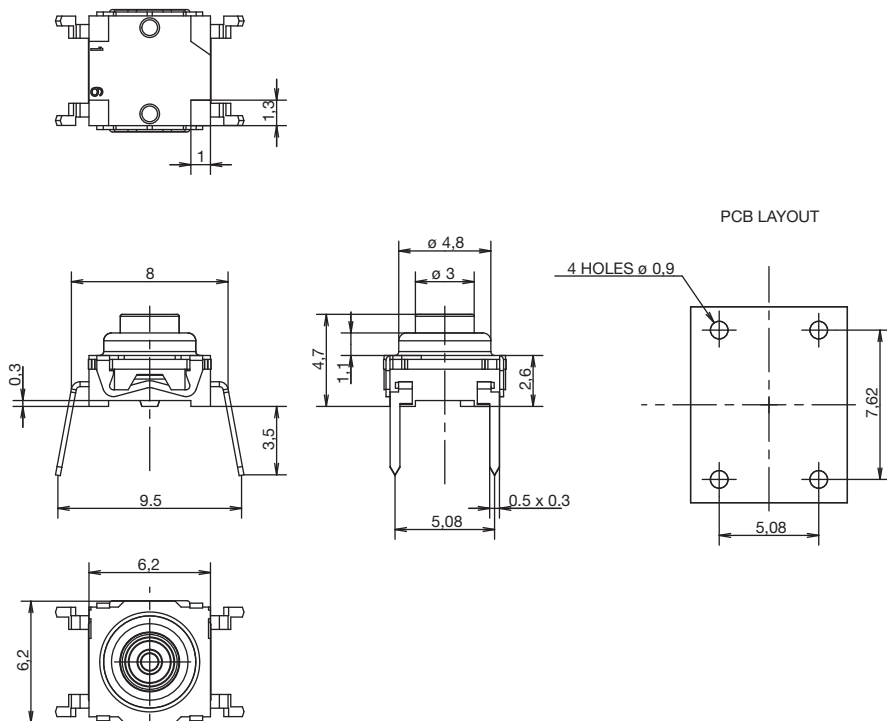

Tactile Switches

B



First Angle
Projection

Dimensions are shown: mm
Specifications and dimensions subject to change

KSJ Series Spherical Actuator Tact Switches

Features/Benefits

- Spherical actuator allows actuation force off center $\pm 30^\circ$ with regard to vertical
- RoHS compliant and compatible
- Designed for mechanisms
- Compliant side actuation

Typical Applications

- Automotive
- Cranes, off road, railway
- Factory automation
- Security systems



B

Tactile Switches

Specification

FUNCTION: Momentary action
 CONTACT ARRANGEMENT: 1 make contact = SPST, N.O.
 DISTANCE BETWEEN BUTTON CENTERS (min.): 7.62 (0.300)
 TERMINALS: PC pins
 SEALING: IP60

Environmental

| | | |
|------------------------|---------------|----------------|
| | Silver | Gold |
| OPERATING TEMPERATURE: | -40°C to 85°C | -40°C to 125°C |
| STORAGE TEMPERATURE: | -40°C to 85°C | -55°C to 125°C |

Packaging

Delivered in boxes of 250 pieces.

Mechanical

| Type | Actuation force N (grams) | Operating life (operations) axial | Operating life (operations) radial | Travel to make (mm) |
|--------------|------------------------------|---|--|------------------------|
| KSJ0M21160SH | 2 ± 0,5 | 100,000 | 30,000 | 0,6 ± 0,3 |
| KSJ0M41180SH | 3,0 ± 0,8 | 100,000 | 30,000 | 0,55 ± 0,25 |
| KSJ0M21180SH | 2 ± 0,5 | 100,000 | 30,000 | 0,35 ± 0,2 |
| KSJ0M91180SH | 3,9 ± 0,8 | 100,000 | 30,000 | 0,7 ± 0,25 |

Electrical

| | | |
|--|--------|--------|
| | Silver | Gold |
| MAXIMUM POWER: | 1 VA | 0.2 VA |
| MAXIMUM VOLTAGE: | 32 VDC | 32 VDC |
| MINIMUM VOLTAGE: | 20 mV | 20 mV |
| MAXIMUM CURRENT: | 50 mA | 10 mA |
| MINIMUM CURRENT: | 1 mA | 1 mA |
| DIELECTRIC STRENGTH (50 Hz, 1 min.): ≥ 250 Vrms | | |
| CONTACT RESISTANCE: ≤ 100 m Ω | | |
| INSULATION RESISTANCE (100V): $\geq 10^9$ ohms | | |
| BOUNCE TIME: ≤ 1 ms | | |

Process

Wave soldering, compatible with lead free soldering profile.

NOTE: Specifications listed above are for switches with standard options. For information on specific and custom switches, consult Customer Service Center.

This data sheet does not provide enough information for applications which require a certain level of quality or safety such as automotive, medical systems, safety equipment. Please contact your sales representative to get contractual specification package.

* Please contact your C&K representative for any question regarding the product integration.

How To Order

Our easy build-a-switch concept allows you to mix and match options to create the switch you need. To order, select desired option from each category and place it in the appropriate box.

However, please note that all the combinations of these options are not feasible.

For any part number different from those listed in the table above, please consult your local representative.

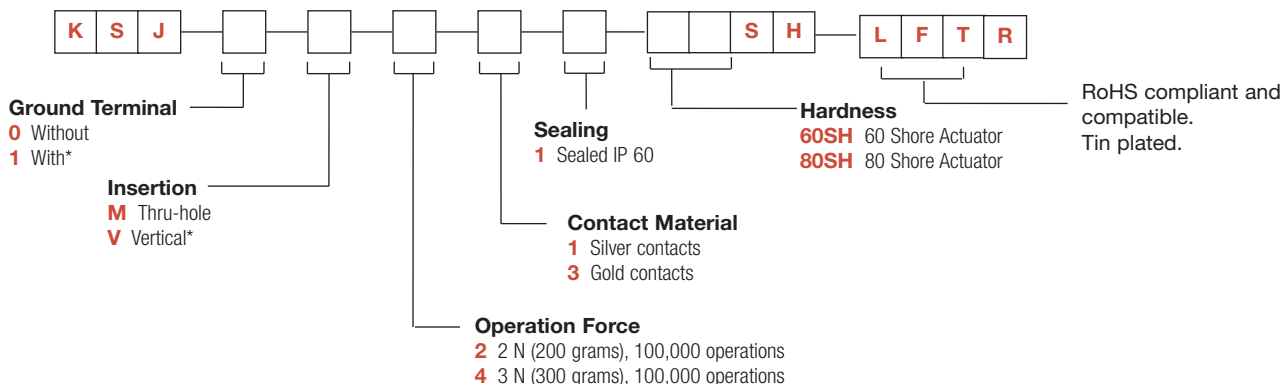

*Note: "1" ground terminal option not available with "V" version. The bracket for the "V" version plays this role.

KSJ Series Spherical Actuator Tact Switches

KSJ

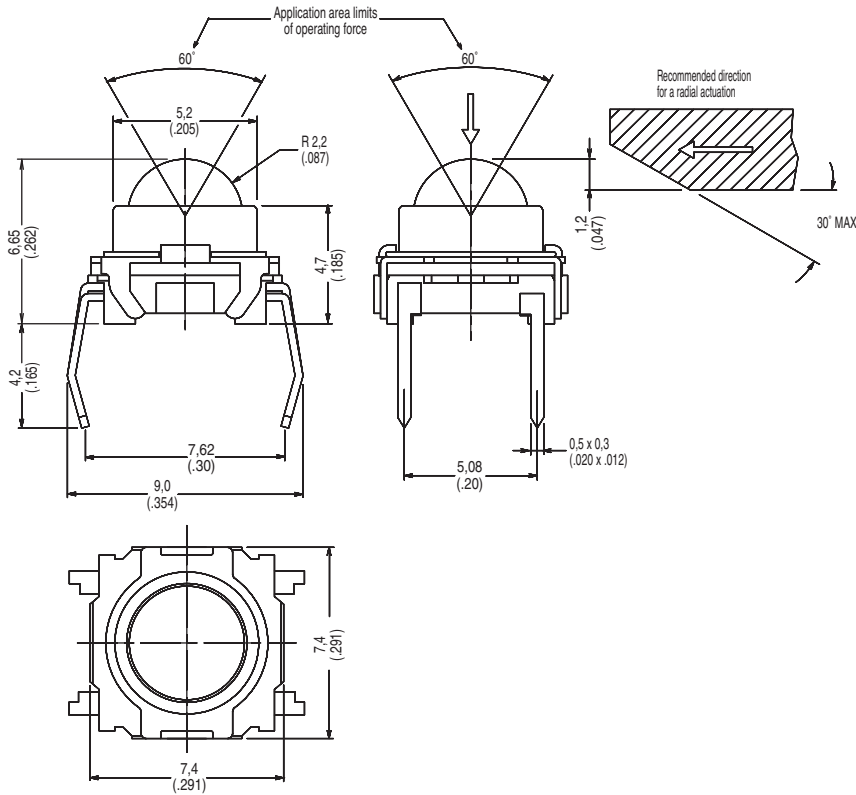

KSJ0M211

INSERTION

M THRU-HOLE

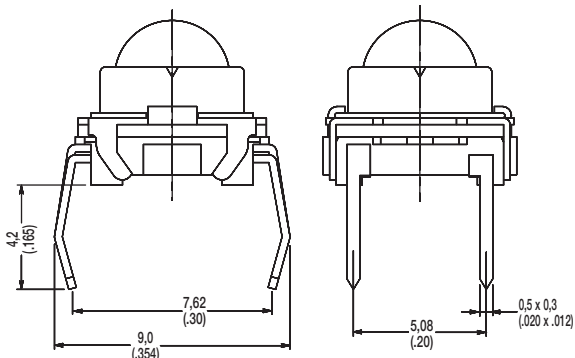

PCB LAYOUT

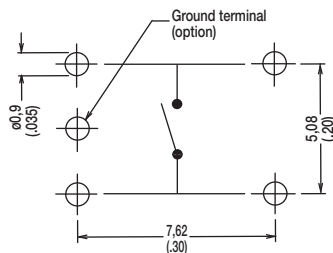

V VERTICAL

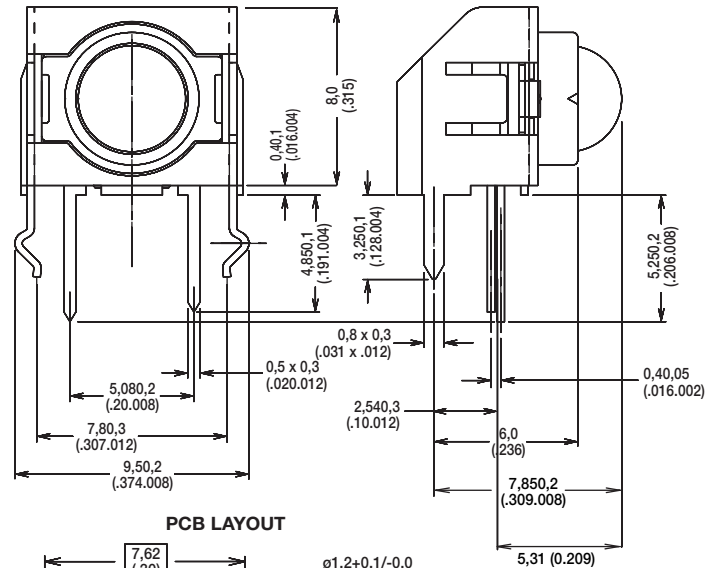

PCB LAYOUT

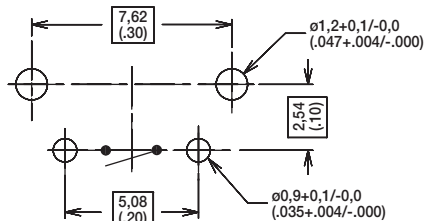

26 jul 16

PTS635 Series 3,5 mm Tact Switches

Features/Benefits

- Compact size 6 x 3.5 mm
- Variety of switch heights
- Choice of actuation force
- RoHS compliant and compatible

Typical Applications

- Consumer products
- Instrumentation
- Computer products
- Industrial

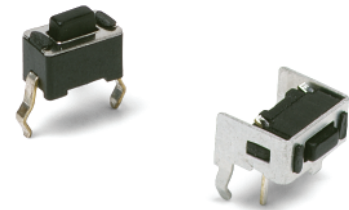

B

Tactile Switches

Specification

FUNCTION: Momentary action
CONTACT ARRANGEMENT: SPST, N.O.
TERMINALS: PC pins

Mechanical

ACTUATION FORCE: PTS635L models: 130 grams.
PTS635H models: 200 grams.
LIFE EXPECTANCY: 20,000 operations.

Electrical

CONTACT RATING: 50 mA @ 12 V DC.
DIELECTRIC STRENGTH: 250 V AC min.
CONTACT RESISTANCE: 100 mΩ max. initial.
INSULATION RESISTANCE: 10¹¹Ω min.

Environmental

OPERATING TEMPERATURE: -40°C to 60°C

NOTE: Specifications listed above are for switches with standard options.
For information on specific and custom switches, consult Customer Service Center.

Process

SOLDERING: Preheating to 100°C for 45 sec. max. Keep flux flush with top surface of PCB; do not apply to component side of PCB and area where terminals are located. Soldering to 255°C for 5 sec. max. Clean by brushing on solder surface. Do not clean switch with solvents.

Materials

BASE: 6/6 nylon or glass filled polyester (PBT) (UL 94V-0).
ACTUATOR: 6/6 nylon or polyacetal (UL 94HB).
COVER PLATE: PTS635S and PTS635V models: Tin plated stainless steel
DOME CONTACTS: Phosphor bronze, silver clad.
STATIONARY CONTACTS: Brass, silver plated.
TERMINALS: Brass, silver plated. Insert molded.

Packaging

Bulk packaging.

Tape & reel for:

PTS635Sx43SMTR, 1700 pcs per reel

How To Order

Our easy build-a-switch concept allows you to mix and match options to create the switch you need. To order, select desired option from each category and place it in the appropriate box.

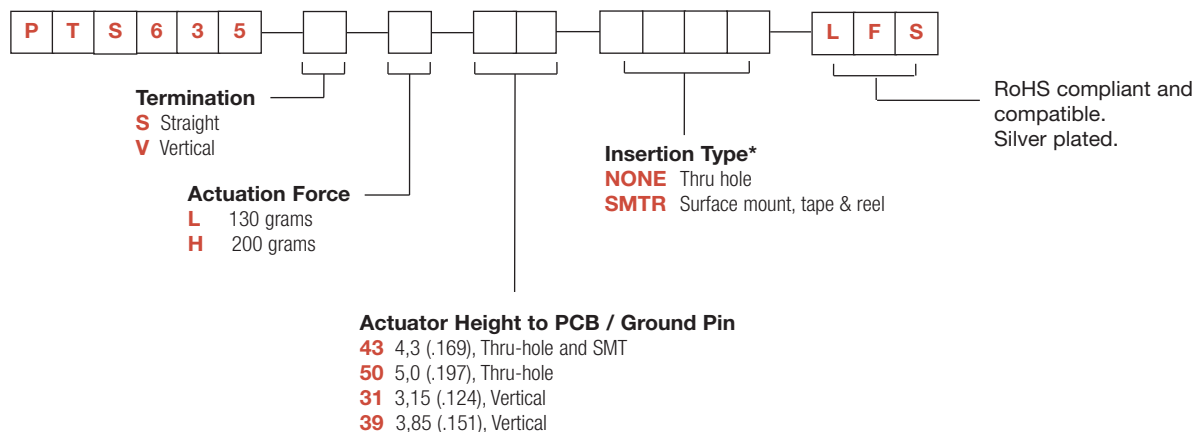

* SMTR only available with PTS635 43 Actuator Height options.

PTS635 Series 3,5 mm Tact Switches

SERIES

PTS635

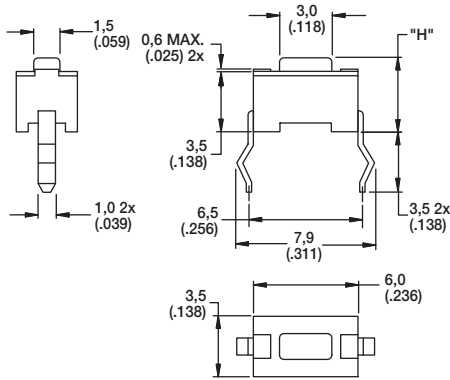

For "H" dimension please refer to chart on next page

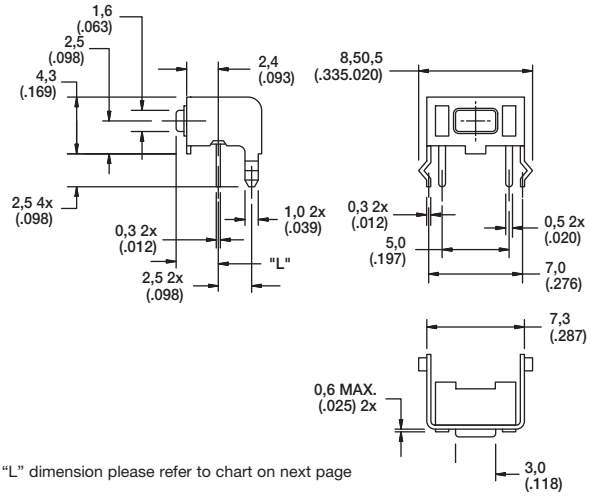

For "L" dimension please refer to chart on next page

Tactile Switches

B

TERMINATION

S STRAIGHT

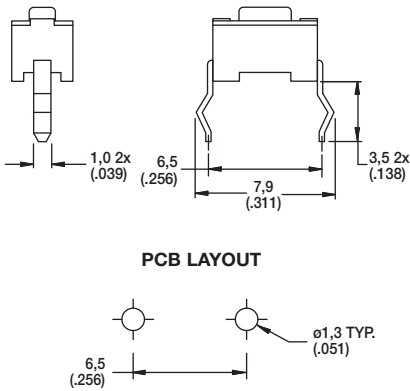

V VERTICAL

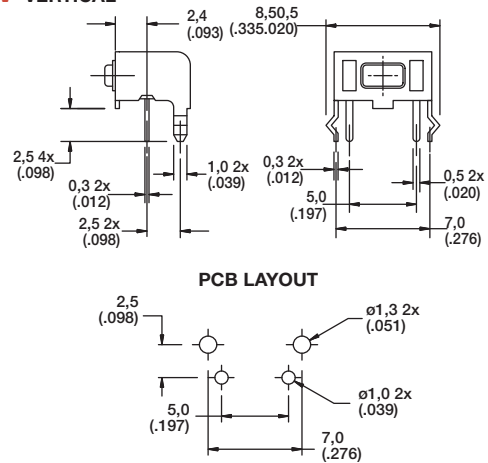

SMT 43

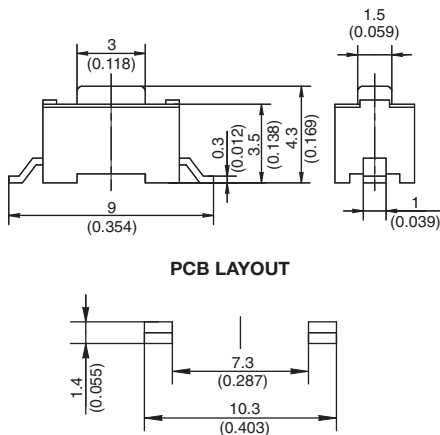

First Angle
Projection

Dimensions are shown: mm
Specifications and dimensions subject to change

PTS635 Series 3,5 mm Tact Switches



ACTUATION FORCE



| OPTION CODE | FORCE |
|-------------|-----------|
| L | 130 grams |
| H | 200 grams |

ACTUATOR HEIGHT

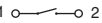

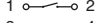
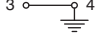
| OPTION CODE | HEIGHT "H" or LENGTH "L" | TERMINATION | SCHEMATIC |
|-------------|--------------------------|-----------------|--|
| 43 | 4,3 (.169) | Thru-hole & SMT | 1  2 |
| 50 | 5,0 (.197) | Thru-hole | 1  2 |
| 31 | 3,15 (.124) | Vertical | 1  2 |
| 39 | 3,85 (.151) | Vertical | 3  4 |

INSERTION TYPE



SMTR 43

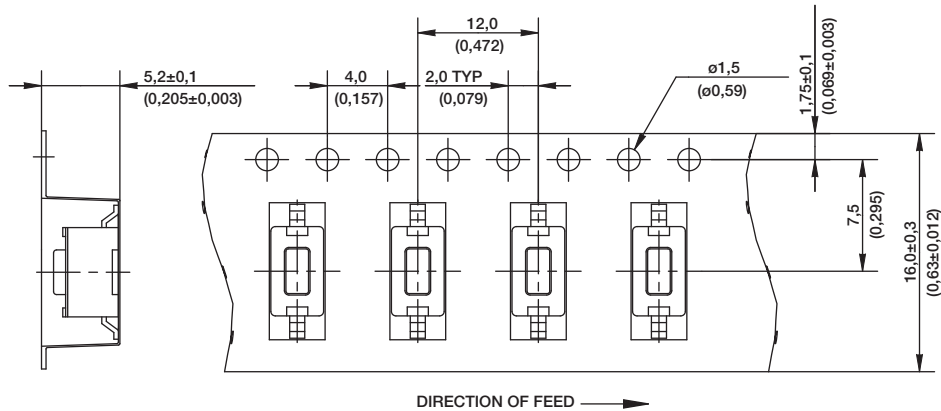

First Angle
Projection

Dimensions are shown: mm
Specifications and dimensions subject to change

PTS641 Series SMT Top Actuated Switches



Features/Benefits

- 6.3 x 6.3 mm footprint
- Multiple heights
- Ground pin option

Typical Applications

- Metering
- White goods
- Home and garden equipment

B

Tactile Switches

Specification

FUNCTION: Momentary action
CONTACT ARRANGEMENT: 1 make contact = SPST N.O.
TERMINALS: G type for SMT

Mechanical

TRAVEL:
0.20 mm ±0.15 mm for 160 & 250 gf
0.30 mm ±0.15 mm for 320 gf
OPERATING LIFE: 100,000 cycles
OPERATION FORCE:
160 gf ±50 gf blue actuator
250 gf ±50 gf red actuator
320 gf ±80 gf black actuator

Packaging

Switches in reels of 1,500 pieces.
Dimensions of reels according to EIA 481B
External diameter 330 mm

Electrical

MAXIMUM VOLTAGE: 12 VDC
MAXIMUM CURRENT DC: 50 mA
DIELECTRIC STRENGTH: 250 VA C (1mm)
CONTACT RESISTANCE: 100 m Ω
INSULATION RESISTANCE: ≥ 100 M Ω
BOUNCE TIME: < 5 ms

Environmental

OPERATING TEMPERATURE: -20°C to 85°C

Process

SOLDERING: This component is suited to the following methods:
Infrared Reflow Soldering in accordance with IEC61760-1

NOTE: Specifications listed above are for switches with standard options.
For information on specific and custom switches, consult Customer Service Center.

How To Order

Our easy build-a-switch concept allows you to mix and match options to create the switch you need. To order, select desired option from each category and place it in the appropriate box.

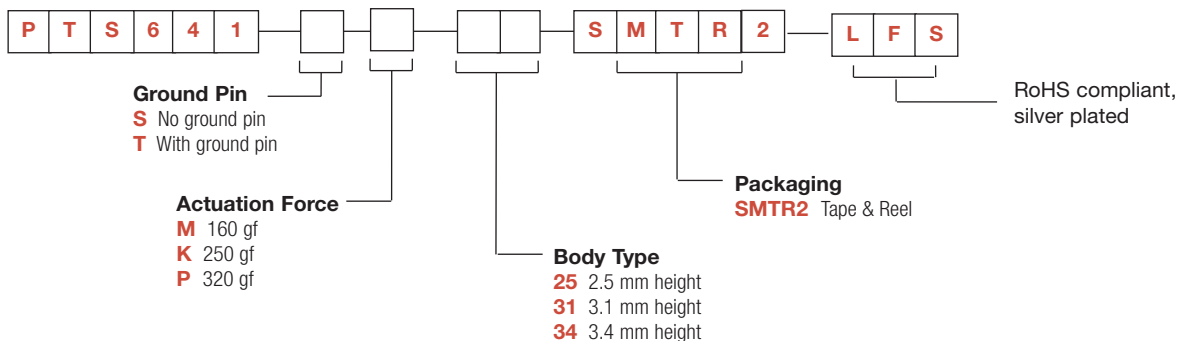

PTS641 Series SMT Top Actuated Switches

NO GROUND PIN H = 2.5, 3.1, or 3.4 mm

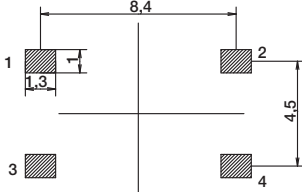
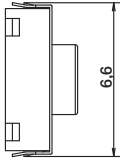
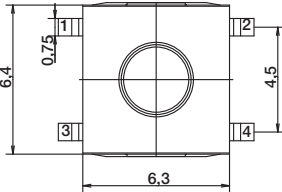
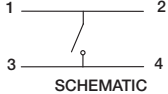
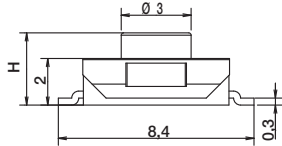

RECOMMENDED PCB LAYOUT

GROUND PIN H = 2.5, 3.1, or 3.4 mm

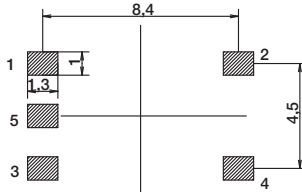
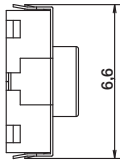
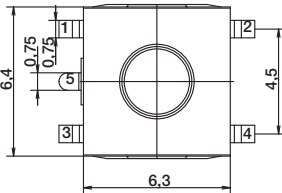
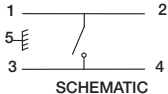
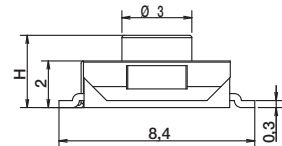

RECOMMENDED PCB LAYOUT



Tactile Switches



Dimensions are shown: mm
Specifications and dimensions subject to change

PTS645 Series 6 mm Tact Switches

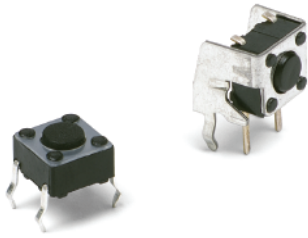

Features/Benefits

- Compact size 6 x 6 mm
- Variety of actuator lengths
- Choice of actuation force
- RoHS compliant and compatible

Typical Applications

- Consumer products
- Instrumentation
- Computer products
- Industrial

B

Tactile Switches

Specification

FUNCTION: Momentary action
CONTACT ARRANGEMENT: SPST, N.O.
TERMINALS: PC pins

Mechanical

ACTUATION FORCE: 130 grams, 160 grams, 200 grams, 260 grams
LIFE EXPECTANCY: 100,000 operations.

Electrical

CONTACT RATING: 50 mA @ 12 V DC.
DIELECTRIC STRENGTH: 250 V AC min.
CONTACT RESISTANCE: 100 mΩ max. initial.
INSULATION RESISTANCE: 10¹¹ Ω min.

Environmental

OPERATING TEMPERATURE: -20°C to 60°C

Process

SOLDERING: Preheating to 100°C for 45 sec. max. Keep flux flush with top surface of PCB; do not apply to component side of PCB and area where terminals are located. Soldering to 255°C for 5 sec. max. Clean by brushing on solder surface. Do not clean switch with solvents.

Packaging

Bulk packaging.

Tape & reel for the SMT type:

Reels of 1,000 pieces for 4,3 and 5,0 mm height
Reels of 700 pieces for 7,0 mm height
Reels of 500 pieces for 9,5 mm height
Reels of 400 pieces for 13,0 mm height

NOTE: Specifications listed above are for switches with standard options.
For information on specific and custom switches, consult Customer Service Center.

How To Order

Our easy build-a-switch concept allows you to mix and match options to create the switch you need. To order, select desired option from each category and place it in the appropriate box.

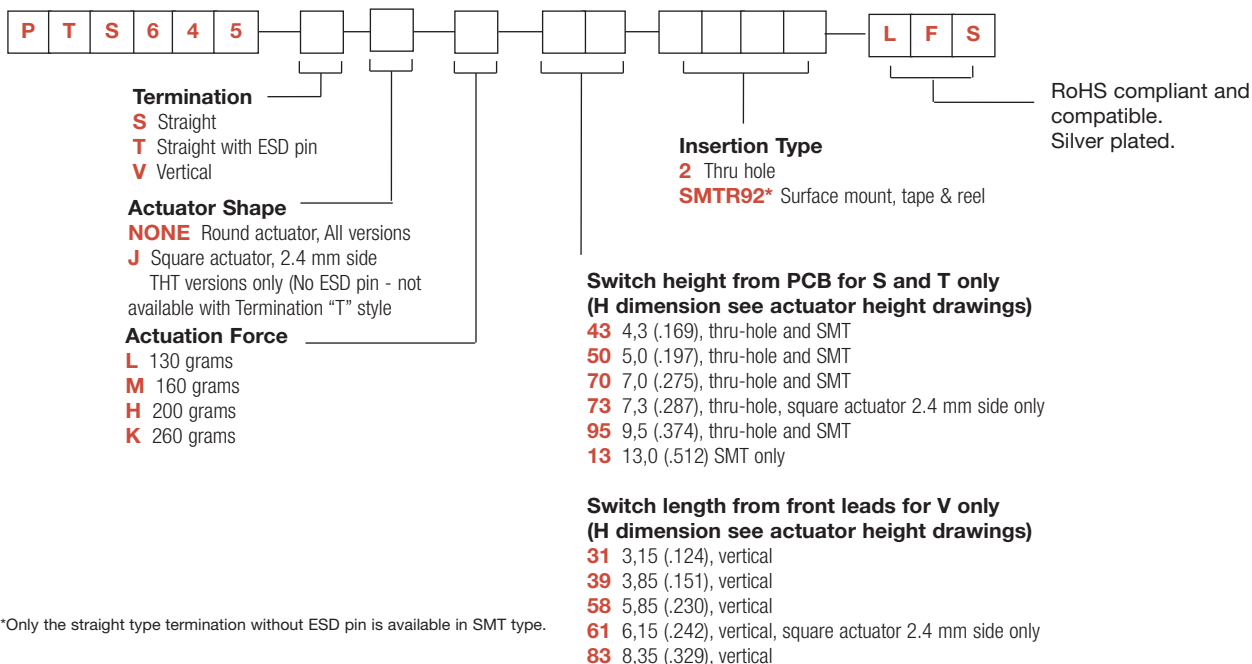

*Only the straight type termination without ESD pin is available in SMT type.



Dimensions are shown: mm
Specifications and dimensions subject to change

PTS645 Series 6 mm Tact Switches

TERMINATION

S STRAIGHT

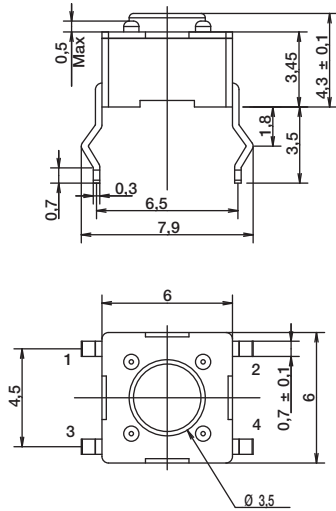

SCHEMATIC

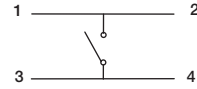

PCB LAYOUT

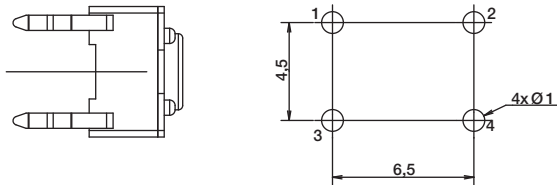

T STRAIGHT WITH ESD PIN

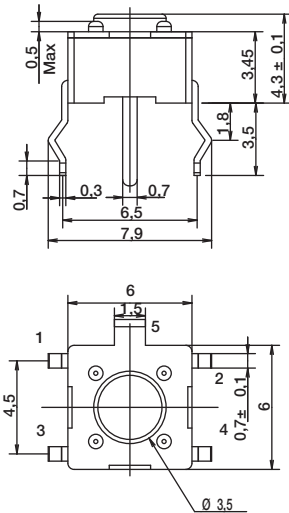

SCHEMATIC

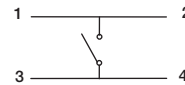

PCB LAYOUT

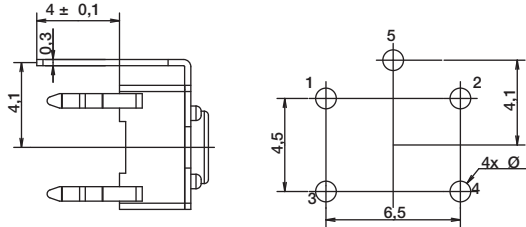

V VERTICAL

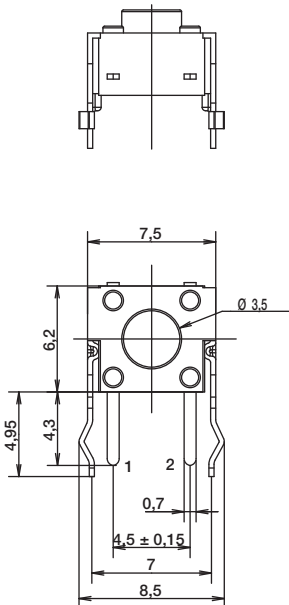

SCHEMATIC

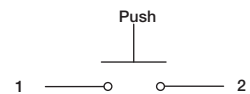

PCB LAYOUT

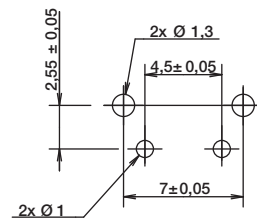

Dimensions are shown in mm
Specifications and dimensions subject to change

PTS645 Series 6 mm Tact Switches

TERMINATION

SMT

FOR 4.3, 5.0, 7.0, 9.5 MM HEIGHT

13.0 MM HEIGHT ONLY

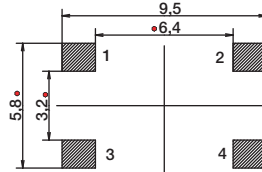
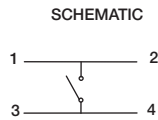
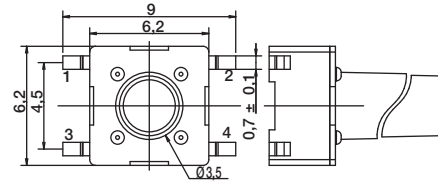
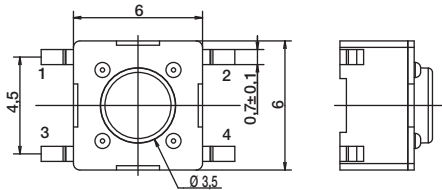
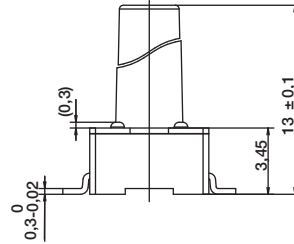
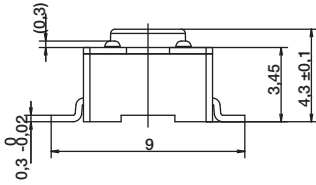

PCB LAYOUT

ACTUATOR SHAPE

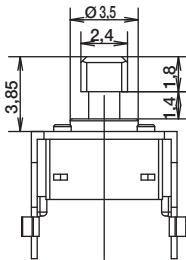

SCHEMATIC

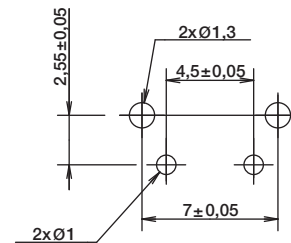
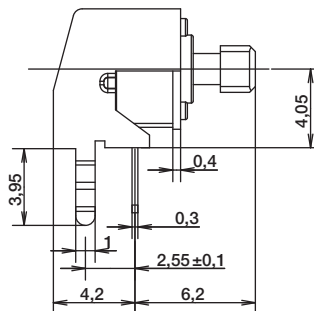
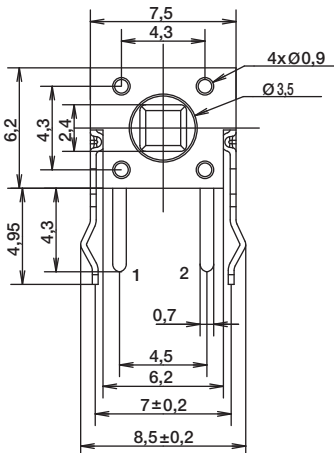
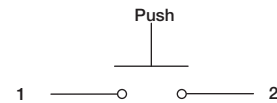

RECOMMENDED PCB LAYOUT

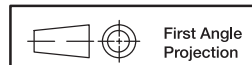

Dimensions are shown: mm
Specifications and dimensions subject to change

PTS645 Series 6 mm Tact Switches

ACTUATOR SHAPE

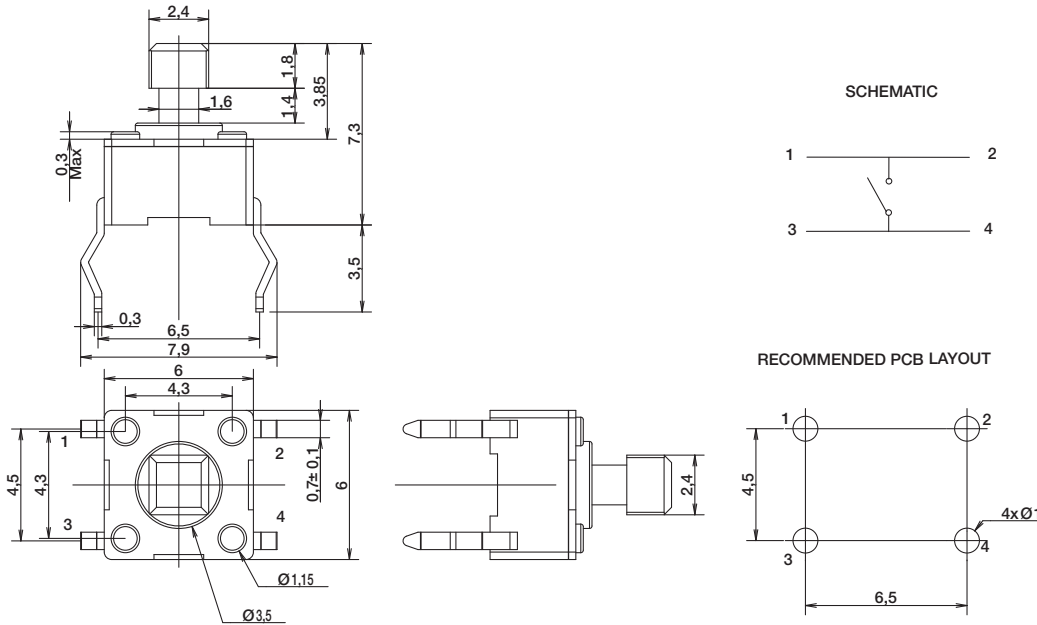

B

Tactile Switches

ACTUATION FORCE

| OPTION CODE | FORCE |
|-------------|-----------------|
| L | 130 grams Black |
| M | 160 grams Blue |
| H | 200 grams Gray |
| K | 260 grams Red |

ACTUATOR HEIGHT

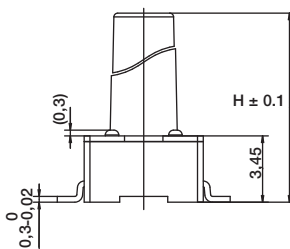

Switch height from PCB for S and T only

| OPTION CODE | DIMENSION H | TERMINATION | SCHEMATIC | |
|-------------|-------------|-------------------|-----------------|--------------|
| | | | Without EMC pin | With EMC pin |
| 43 | 4,3 (.169) | Thru-hole and SMT | | |
| 50 | 5,0 (.197) | Thru-hole and SMT | | |
| 70 | 7,0 (.275) | Thru-hole and SMT | | |
| 95 | 9,5 (.374) | Thru-hole and SMT | | |
| 13 | 13,0 (.512) | SMT | | |

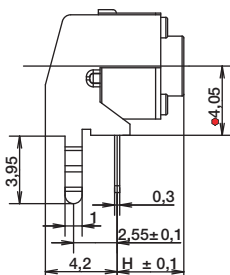

Switch length from front leads for V only

| OPTION CODE | DIMENSION H | TERMINATION | SCHEMATIC | |
|-------------|-------------|-------------|-----------------|--------------|
| | | | Without EMC pin | With EMC pin |
| 31 | 3,15 (.124) | Vertical | | |
| 39 | 3,85 (.151) | Vertical | | |
| 58 | 5,85 (.230) | Vertical | | |
| 83 | 8,35 (.329) | Vertical | | |



Dimensions are shown: mm
Specifications and dimensions subject to change

PTS645 Series 6 mm Tact Switches

TAPE & REEL

B

Tactile Switches

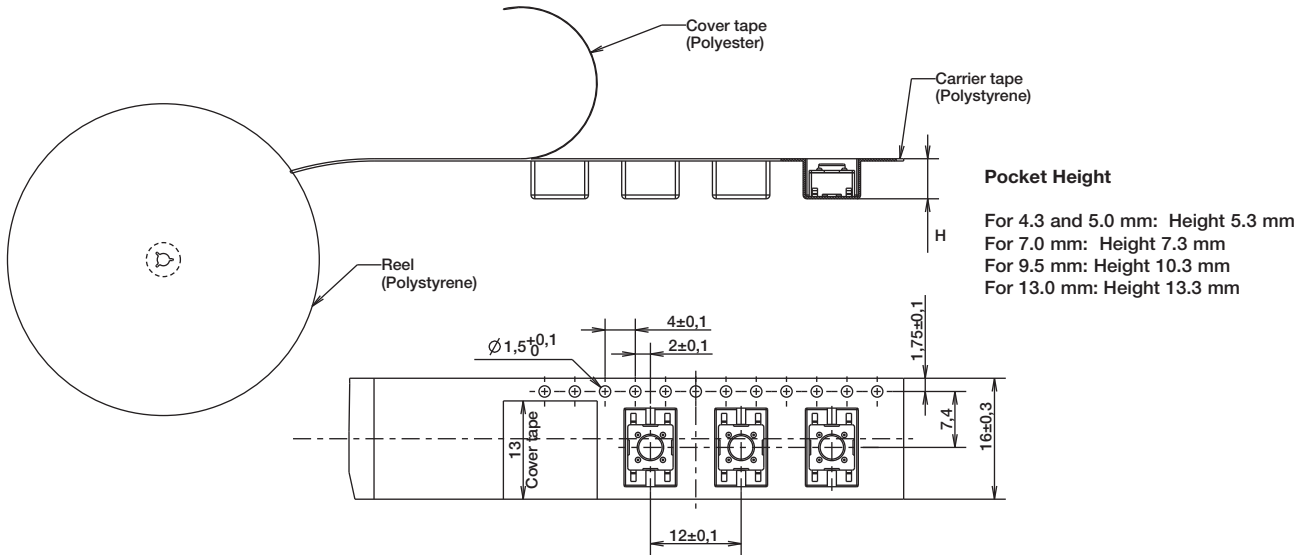

PTS645 V SMT Series 6 mm SMT Side Actuated Tact Switch

Features/Benefits

- Full SMT processing
- Strong PCB soldering pads
- Compact 6 x 6 mm design

Typical Applications

- Consumer Products
- Set Top and Access Boxes
- Instrumentation
- Home and Garden Equipment



Specification

FUNCTION: Momentary action
 CONTACT ARRANGEMENT: 1 make contact = SPST, N.O.
 TERMINALS: G type for SMT
 TRAVEL: 0.25 mm +0.2/-0.1 mm
 OPERATING LIFE: 100,000 cycles

Mechanical

| Part Number | Operating Force (gf) | Actuator Color |
|------------------------|----------------------|----------------|
| PTS645 VN13 SMTR92 LFS | 100 ± 30 | Dark grey |
| PTS645 VM13 SMTR92 LFS | 160 ± 50 | Yellow green |

Electrical

MAXIMUM VOLTAGE: 12 V DC
 MAXIMUM CURRENT: 50 mA
 DIELECTRIC STRENGTH: 100 V AC (1mn)
 CONTACT RESISTANCE: ≤ 100 mΩ
 INSULATION RESISTANCE: ≥ 100 MΩ
 BOUNCE TIME: ≤ 10 ms

Environmental

OPERATING TEMPERATURE: -20°C to 70°C
 STORAGE TEMPERATURE: -30°C to 80°C

Process

SOLDERING: This component is suited to the following methods:
 Infrared Reflow Soldering in accordance with IEC61760-1

Recommended solder paste thickness is ≥ 15µm

Packaging

In reels of 650 pieces
 Dimensions of reels according to EIA 481B
 External diameter 330 mm

NOTE: Specifications listed above are for switches with standard options.
 For information on specific and custom switches, consult Customer Service Center.

How To Order

Our easy build-a-switch concept allows you to mix and match options to create the switch you need. To order, select desired option from each category and place it in the appropriate box.

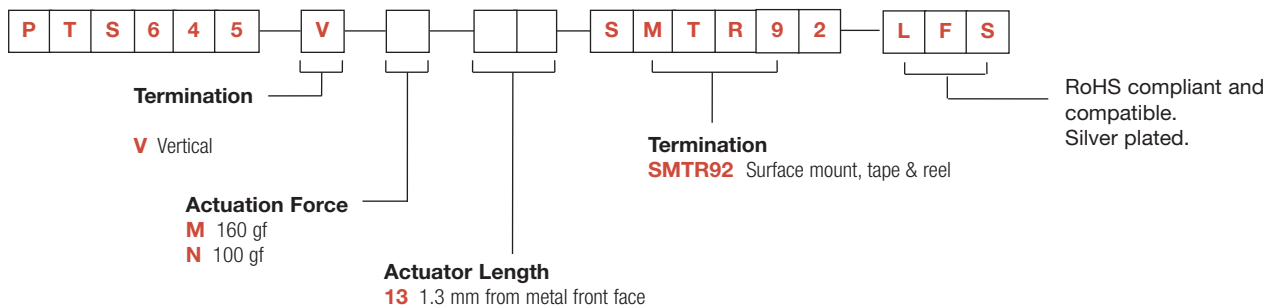

PTS645 V SMT Series

6 mm SMT Side Actuated Tact Switch

RECOMMENDED PCB LAYOUT

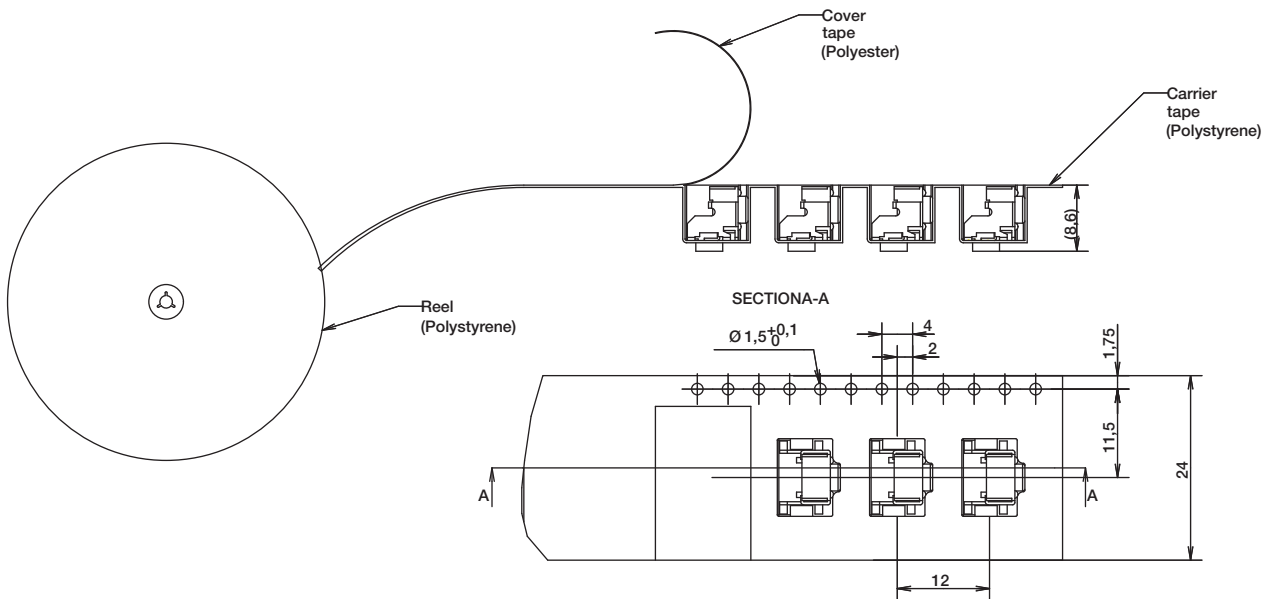
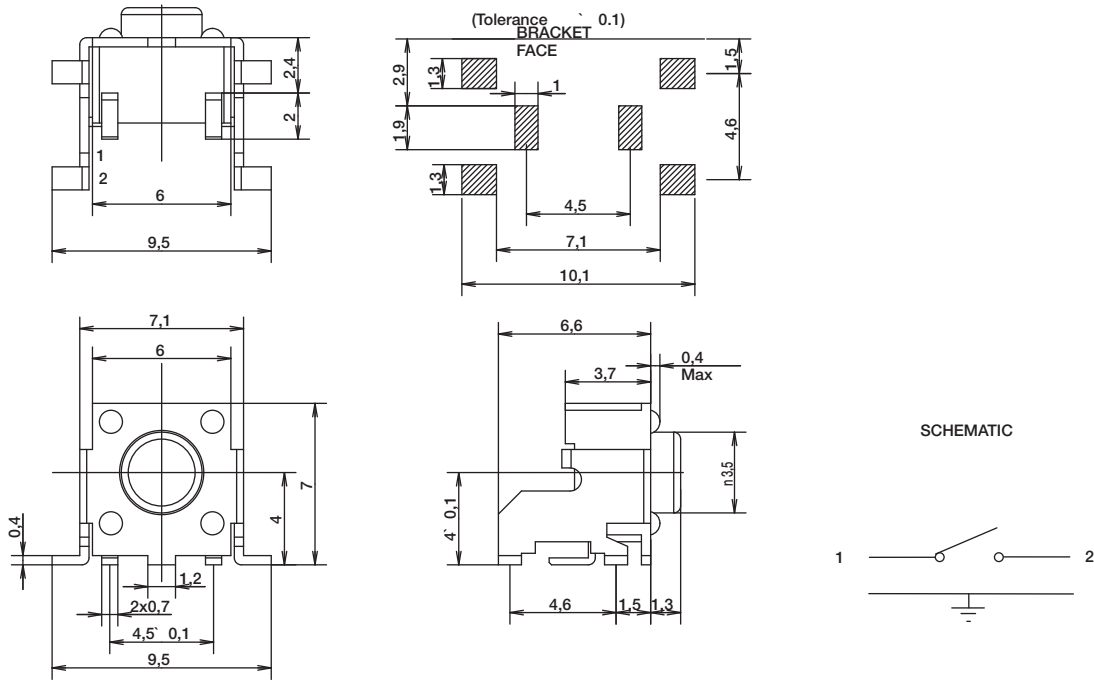

PTS125 Series 12 mm Tact Switches



Features/Benefits

- THT and SMT terminations
- Various heights
- Snap fit actuator option

Typical Applications

- Consumer products
- Instrumentation
- Computer products
- Industrial



B

Tactile Switches

Specification

FUNCTION: Momentary action
CONTACT ARRANGEMENT: 1 make contact SPST, N.O.
TERMINALS: PC pins for THT and G type for SMT
TRAVEL: 0.30 mm ± 0.15 mm

Mechanical

OPERATING LIFE: 200,000 cycles
OPERATING FORCE: 180 gf ± 50
250 gf ± 50

Electrical

MAX VOLTAGE: 12 VDC
MAX CURRENT: 50 mA
DIELECTRIC STRENGTH: 250 V AC (1mn)
CONTACT RESISTANCE: <100 mΩ
INSULATION RESISTANCE: >100MΩ
BOUNCE TIME: < 5 ms

NOTE: Specifications listed above are for switches with standard options.
For information on specific and custom switches, consult Customer Service Center.

Environmental

OPERATING TEMPERATURE: -20°C to 70°C

Process

SOLDERING: This component is suited to the following methods:
Infrared reflow soldering in accordance with IEC 61760-1 for SMT version
Wave soldering compatible with lead free soldering profile

Packaging

| Soldering Style | Height | Packaging | Parts per Packaging |
|-----------------|------------------|-------------|---------------------|
| THT | All heights | Plastic bag | 500 |
| SMT | 4.3 mm | tape & reel | 900 |
| SMT | 4.3 mm with pegs | tape & reel | 600 |
| SMT | 7.3 mm | tape & reel | 500 |
| SMT | 7.3 mm with pegs | tape & reel | 500 |
| SMT | 8.5 mm | tape & reel | 500 |
| SMT | 8.5 mm with pegs | tape & reel | 400 |
| SMT | 12 mm | tape & reel | 250 |

Dimensions of reels according to EIA 481B. External diameter 330 mm.

How To Order

Our easy build-a-switch concept allows you to mix and match options to create the switch you need. To order, select desired option from each category and place it in the appropriate box.

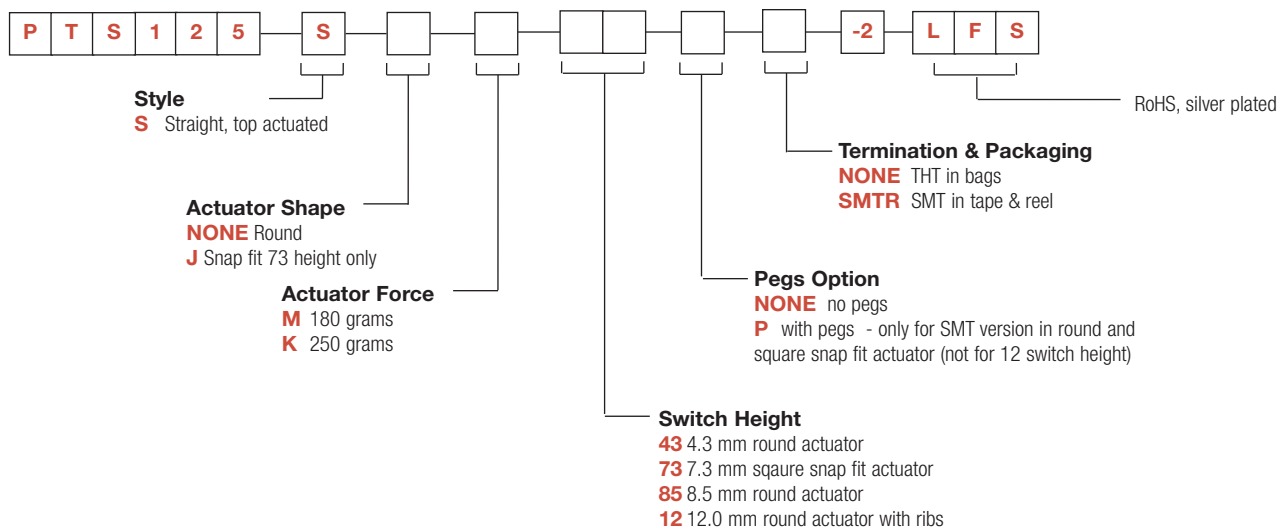

Other heights with the round actuator are available upon request. Different minimum order quantities than the stand may apply.



Dimensions are shown: mm
Specifications and dimensions subject to change

PTS125 Series 12 mm Tact Switches

THT VERSION WITH ROUND ACTUATOR H= 4.3 & 8.5 MM (other height upon request)

B

Tactile Switches

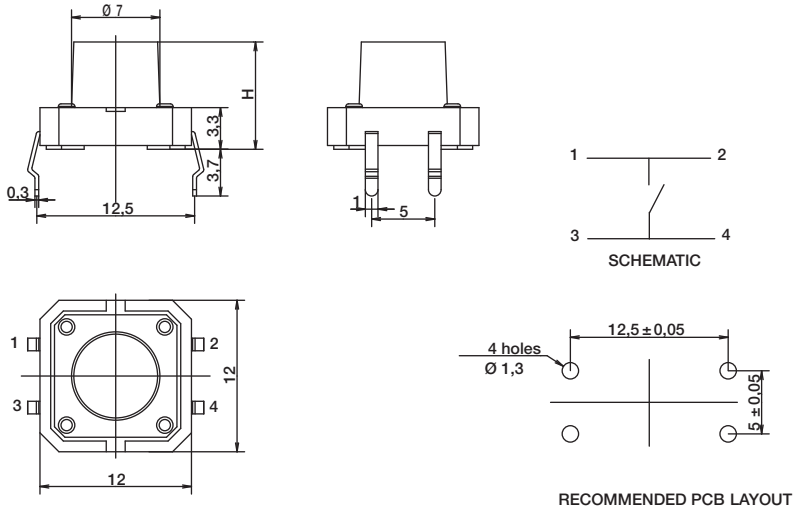

SMT VERSION WITH ROUND ACTUATOR AND PEGS H= 4.3 & 8.5 MM (other height upon request)

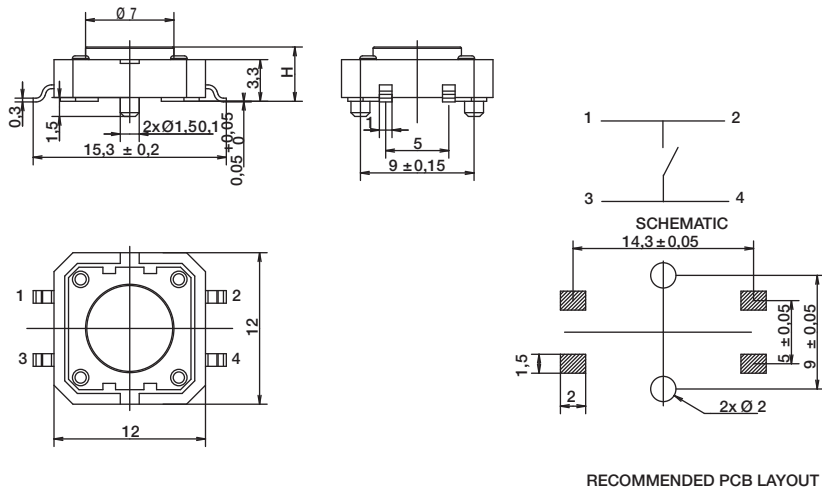

PTS125 Series 12 mm Tact Switches

THT VERSION WITH SQUARE SNAP FIT ACTUATOR H= 7.3 MM

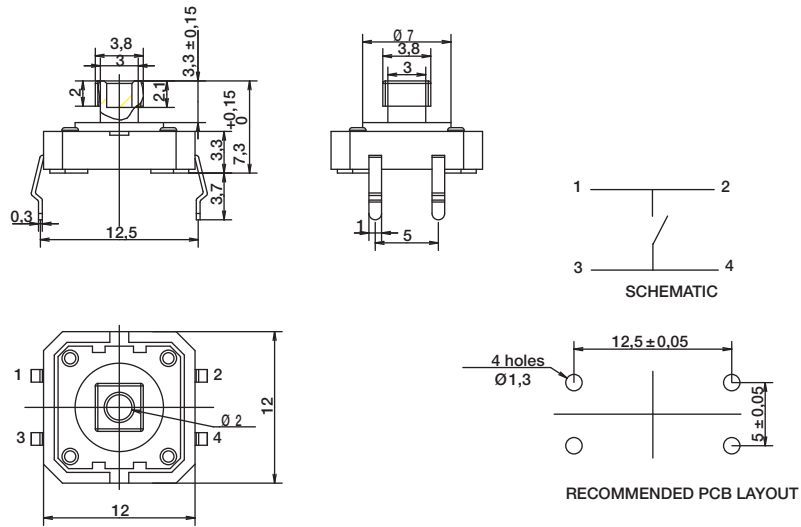

SMT VERSION WITH SQUARE SNAP FIT ACTUATOR AND PEGS H= 7.3 MM

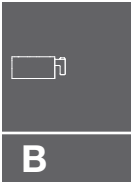
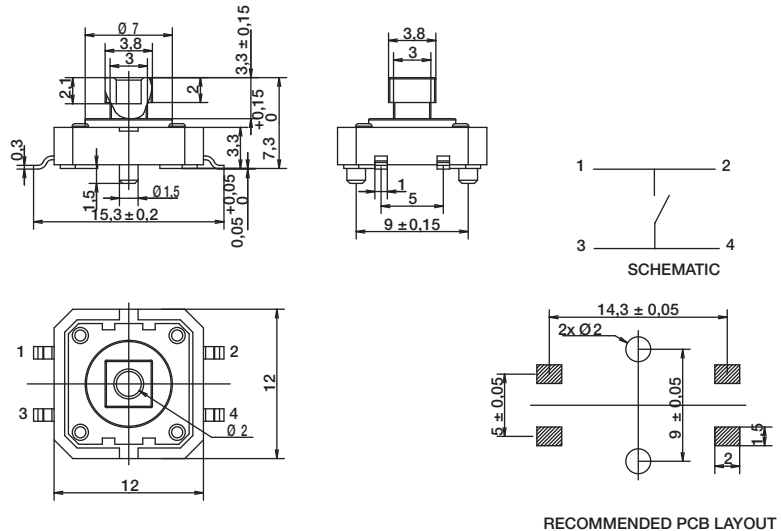

B
Tactile Switches



Dimensions are shown: mm
Specifications and dimensions subject to change

PTS125 Series 12 mm Tact Switches

THT VERSION WITH ROUND RIBBED ACTUATOR H= 12.0 MM

Tactile Switches

B

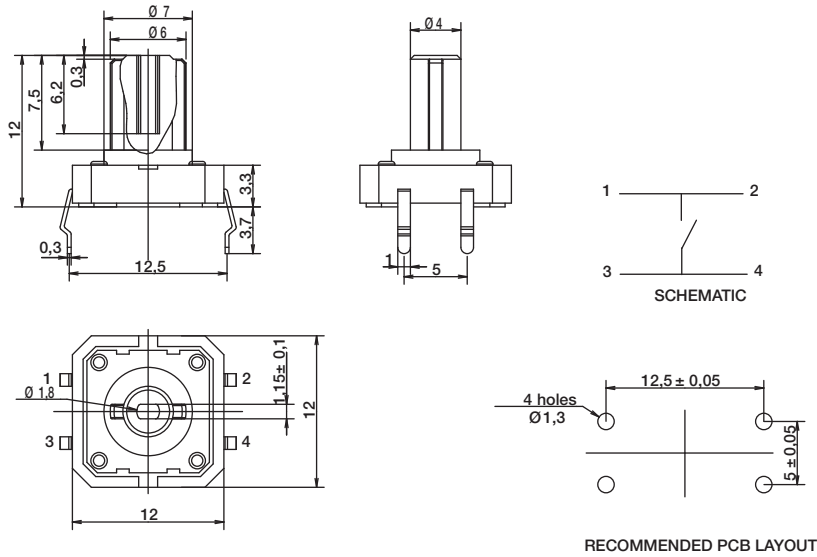

SMT VERSION WITH ROUND RIBBED ACTUATOR H= 12.0 MM

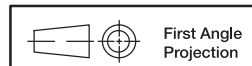
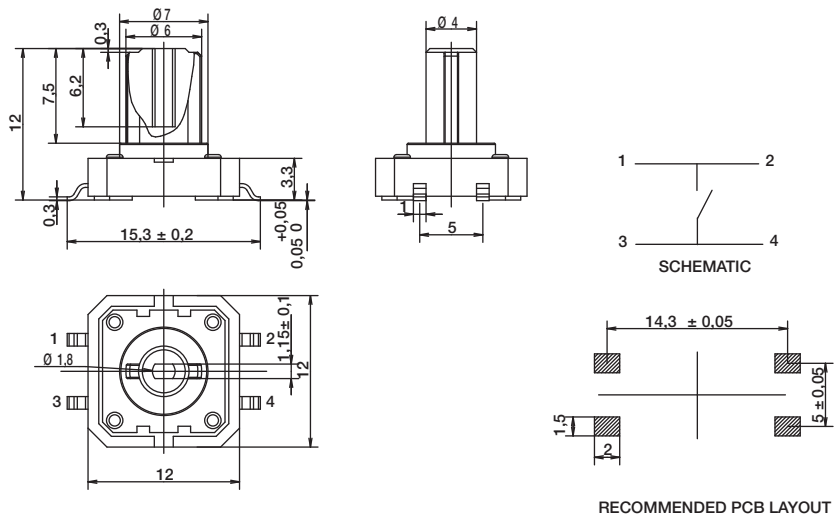

Dimensions are shown: mm
Specifications and dimensions subject to change

ITS Series Illuminated Tact Switch

Features/Benefits

- Vertical and right angle SMT models
- Vertical and right angle thru-hole models
- Multiple caps and legends
- Several LED colors and bi-color options
- RoHS compliant /compatible

Typical Applications

- Consumer electronics
- Server/storage
- Medical devices
- Test/Measurement/Instrumentation
- Audio/Video
- Computers/Peripherals
- Security

NEW
Right
Angle
SMT



B

Tactile Switches

Specification

FUNCTION: N.O. momentary action
TERMINALS: SMT & Thru-hole

Mechanical

OPERATING FORCE: 160 ± 50gf for V1; V2; V3; R1; R2 models
220 ± 50 gf for R3 model
OPERATING LIFE: 50,000 cycles (250m Ω max)
RECOMMENDED OPERATING STROKE: 0.25mm ± 0.1mm

Electrical

RATING: 50mA @ 12VDC
CONTACT RESISTANCE: <100m Ω (initial)
DIELECTRIC WITHSTANDING VOLTAGE:
>250VAC (50-60 Hz) between terminals - 1 min.Ω
INSULATION RESISTANCE: >100M Ω
BOUNCE TIME: <10ms

Packaging

Thru-hole: 200 pieces per tray
SMT: tape & reel (see V2 or V3 mounting style drawings)

Environmental

OPERATING TEMPERATURE: -25°C to +70°C
STORAGE TEMPERATURE: -25°C to +80°C

Process

SOLDERABILITY: Thru-hole - wave compatible
SMT - convection or IR reflow compatible

Materials

CONTACTS/TERMINALS: Base metal; brass
Plating; Ag
DOME: Base metal: Phosphor bronze
Plating; Ag

BASE: PA
ACTUATOR: PA
COVER: PA

Caps

Caps are ordered separately and shipped bulk. Thru-hole versions available with caps assembled under custom part number. Contact customer service for details.

How To Order

Our easy build-a-switch concept allows you to mix and match options to create the switch you need. To order, select desired option from each category and place it in the appropriate box.

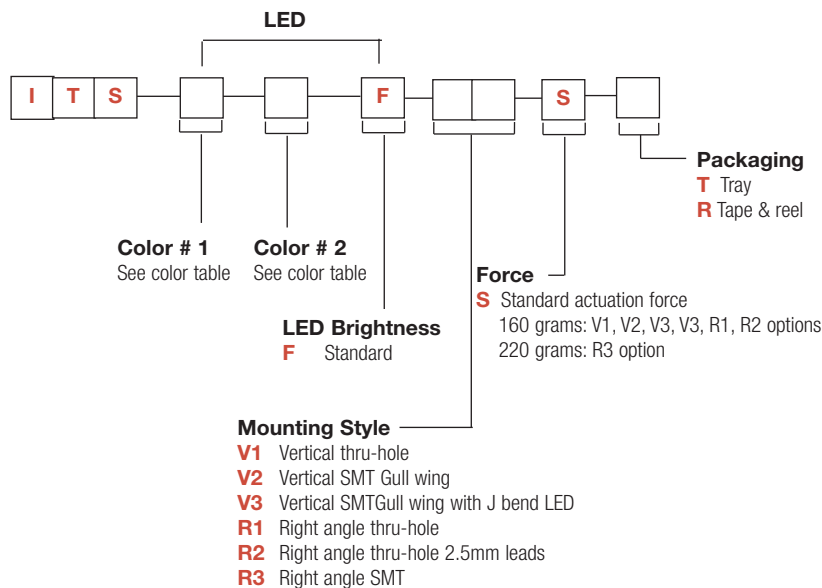

| LED Color | |
|-----------|--------------|
| 00 | No light |
| 10 | Red |
| 12 | Red/Yellow |
| 13 | Red/Green |
| 14 | Red/Blue |
| 20 | Yellow |
| 21 | Yellow/Red |
| 23 | Yellow/Green |
| 30 | Green |
| 31 | Green/Red |
| 32 | Green/Yellow |
| 40 | Blue |
| 41 | Blue/Red |
| 50 | White |
| 60 | True green |

* Other colors available by request



Dimensions are shown: mm
Specifications and dimensions subject to change

ITS Series Illuminated Tact Switch

LED COLOR / BRIGHTNESS

| LED Characteristic | units | Standard LED Color Options | | | | | |
|--|-----------|----------------------------|-----------------|-----------------|-----------------|---|-----------------|
| | | Red (1) | Yellow (2) | Green (3) | Blue (4) | White (5) | True Green (6) |
| Recommended Operating | mA @ 5VDC | 20mA | 20mA | 20mA | 20mA | 20mA | 20mA |
| Forward Current | mA | 30 mA | 30 mA | 30 mA | 30 mA | 30 mA | 30 mA |
| Peak Pulsing Current (1/8 duty @ 1kHz) | mA | 125 mA | 125 mA | 125 mA | 125 mA | 125 mA | 125 mA |
| Power Dissipation | mW | 75 mW | 75 mW | 75 mW | 108 mW | 108 mW | 108 mW |
| Forward Voltage @ 20mA | Volts | 2.5 Volts Max. | 2.5 Volts Max. | 2.5 Volts Max. | 3.6 Volts Max. | 3.6 Volts Max. | 3.6 Volts Max. |
| Dominant Wavelength @ 20mA | nm | 637nm (Typical) | 590nm (Typical) | 570nm (Typical) | 465nm (Typical) | CIE Coordinates X= 0.25 ~ 0.33 Y= 0.24 ~ 0.34 | 522nm (Typical) |
| Wavelength at Peak Emission @ 20mA | nm | 645nm (Typical) | 590nm (Typical) | 573nm (Typical) | 460nm (Typical) | | 515nm (Typical) |
| Spectral Half Bandwidth @ 20mA | nm | 20nm (Typical) | 20nm (Typical) | 17nm (Typical) | 25nm (Typical) | | 33nm (Typical) |
| Luminous Intensity @ 20mA | mcd | 50mcd Minimum | 125mcd Minimum | 40mcd Minimum | 100mcd Minimum | 250mcd Minimum | 500mcd Minimum |
| Viewing Angle at 50% LV (@10mA) | degrees | 150° Typical | 120° Typical | 120° Typical | 120° Typical | 150° Typical | 120° Typical |

MOUNTING STYLES

V1 - Vertical Thru-hole

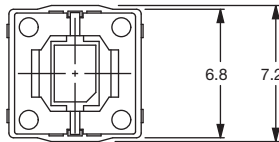

ELECTRICAL SCHEMATIC

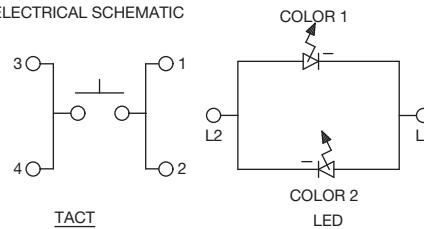

TACT

COLOR 2
LED

DOT SHOWING LED COLOR IS MARKED FOR MINUS POLE SEE SCHEMATIC

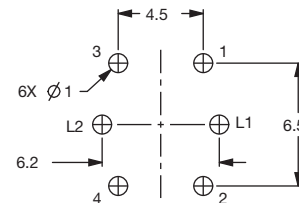
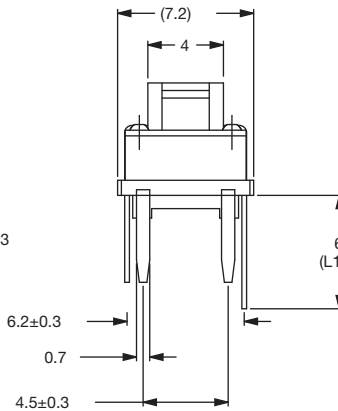
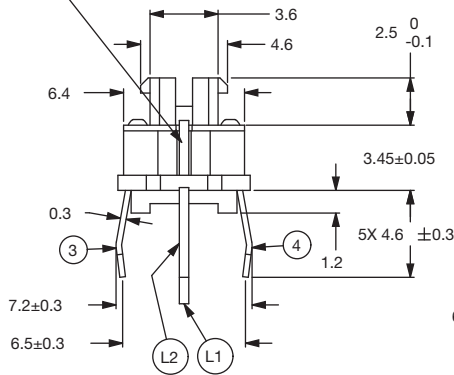

P.C.B. LAYOUT

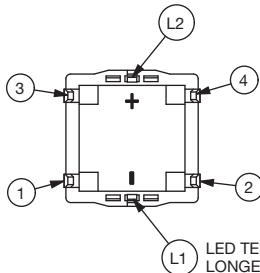

TRAY PACKAGING: 200 PIECES

ITS Series Illuminated Tact Switch

MOUNTING STYLES

V2 - Vertical SMT; Gullwing

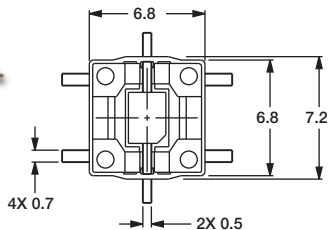

ELECTRICAL SCHEMATIC

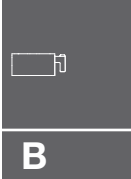
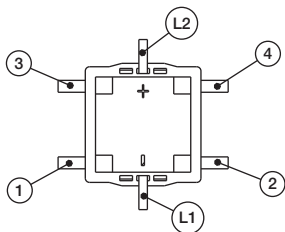
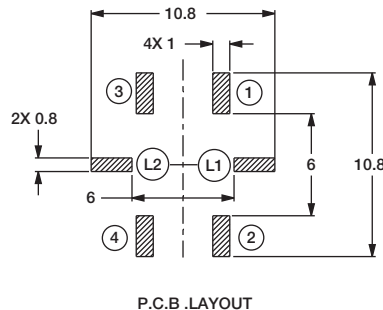
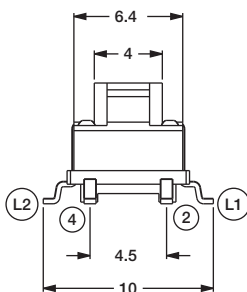
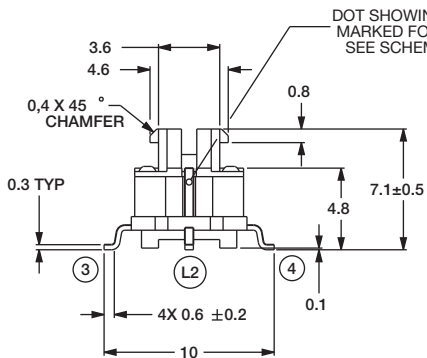
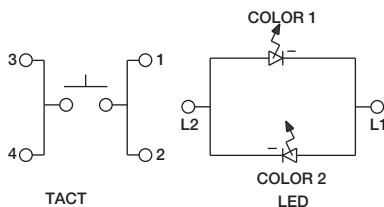

B

Tactile Switches

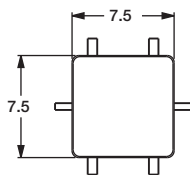

TAPE & REEL: 500 PIECES

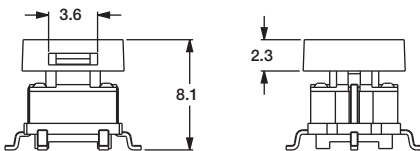

NOTES:
1. SWITCH WITH TEMPORARY PICK AND PLACE CAP.

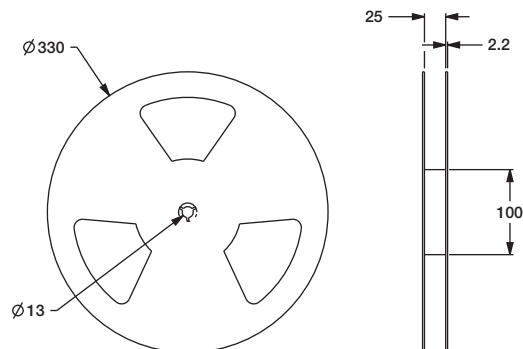
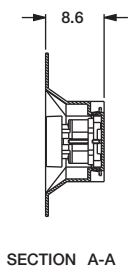
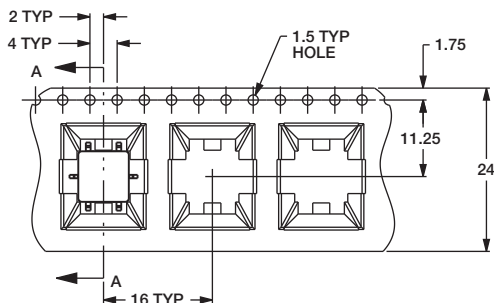

Dimensions are shown: mm
Specifications and dimensions subject to change

ITS Series Illuminated Tact Switch

MOUNTING STYLES

V3 - Vertical SMT; Gull wing with J bend LED

B

Tactile Switches

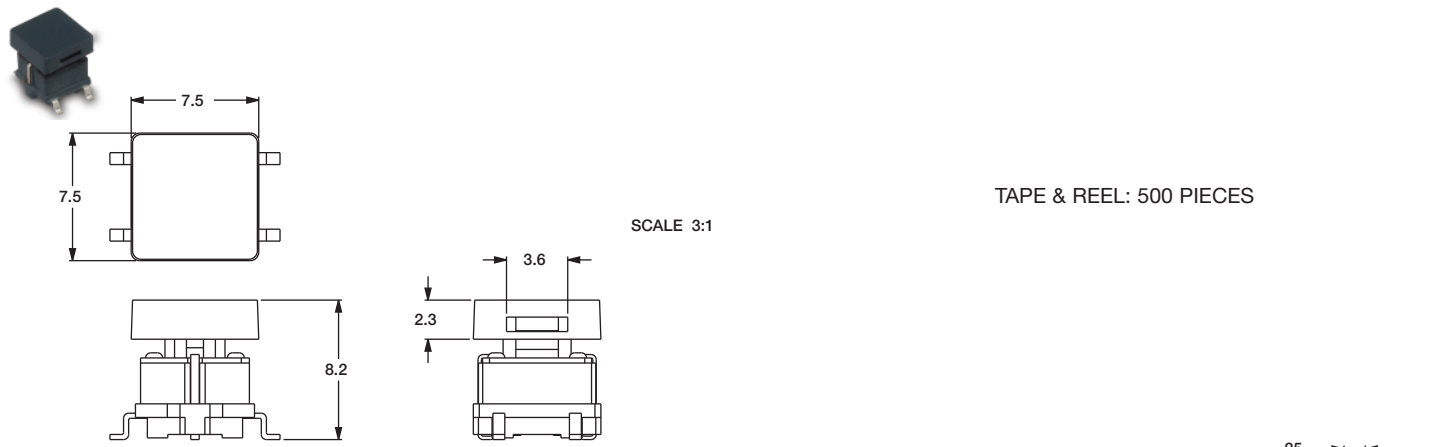
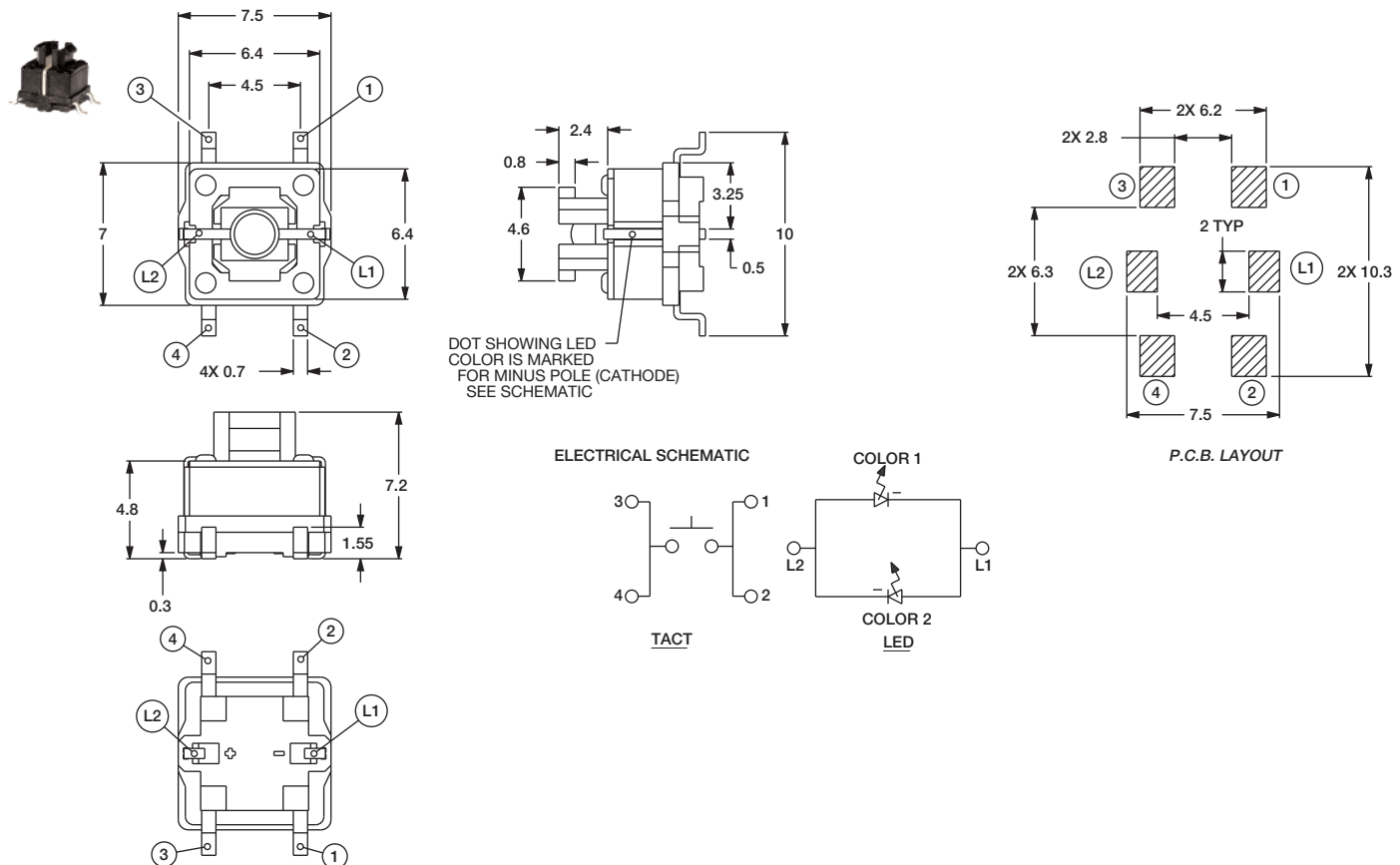

NOTES:
1. SWITCH WITH TEMPORARY PICK AND PLACE CAP.

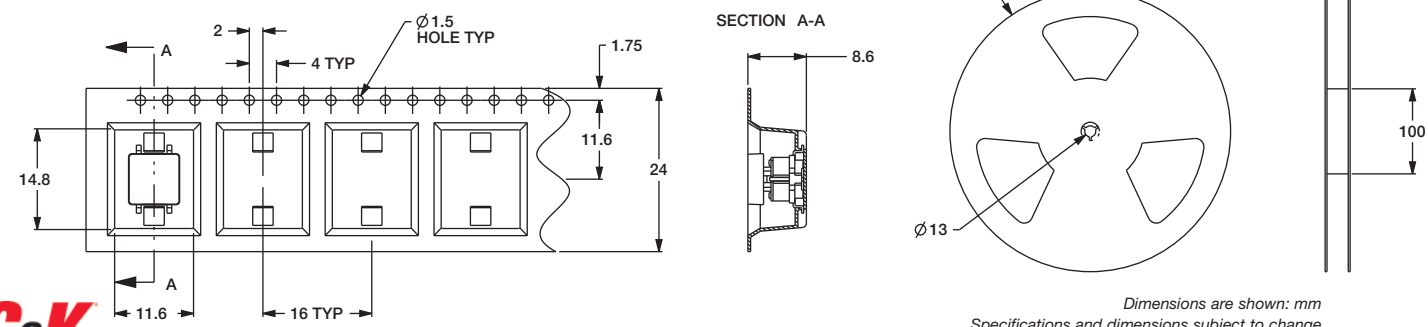

Dimensions are shown: mm
Specifications and dimensions subject to change



ITS Series Illuminated Tact Switch

MOUNTING STYLES

R1 - Right Angle; Thru-hole

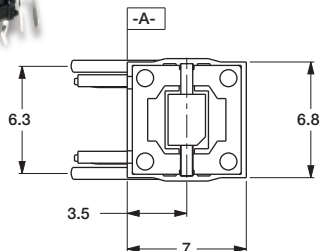

ELECTRICAL SCHEMATIC

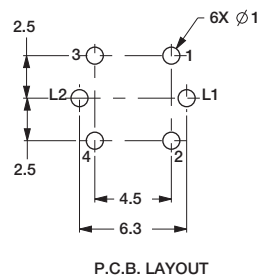
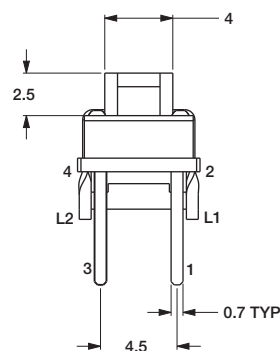
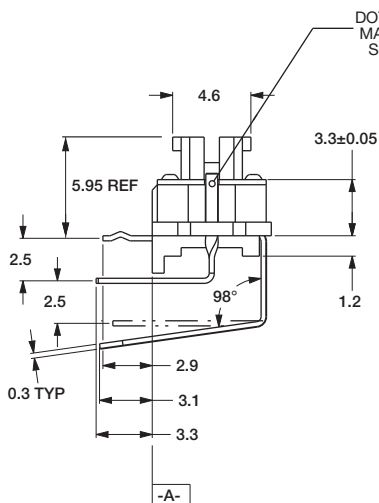
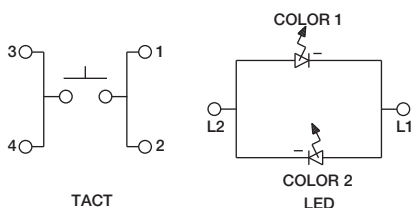

TRAY PACKAGING: 200 PIECES

R2 - Right Angle; Thru-hole 2.5mm leads

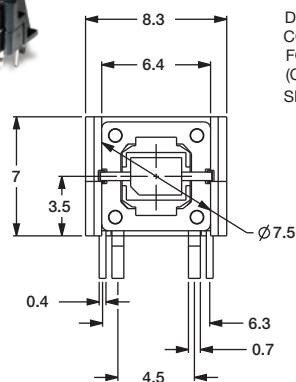

DOT SHOWING LED COLOR IS MARKED FOR MINUS POLE (CATHODE) SEE SCHEMATIC

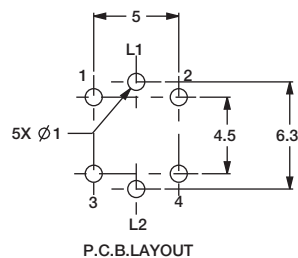
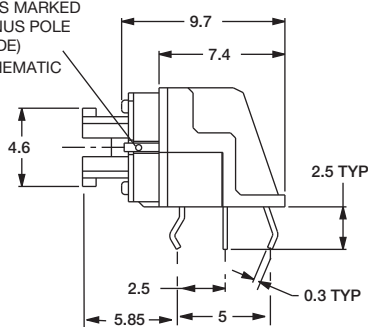

ELECTRICAL SCHEMATIC

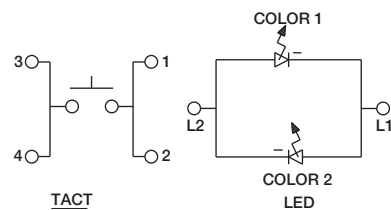

TRAY PACKAGING: 200 PIECES



Dimensions are shown: mm
Specifications and dimensions subject to change

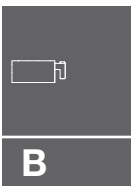

B

Tactile Switches

ITS Series Illuminated Tact Switch

MOUNTING STYLES

R3 - Right Angle, SMT

B

Tactile Switches

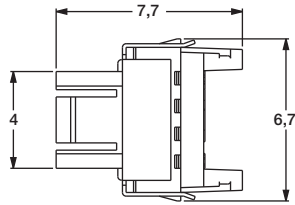

ELECTRICAL SCHEMATIC

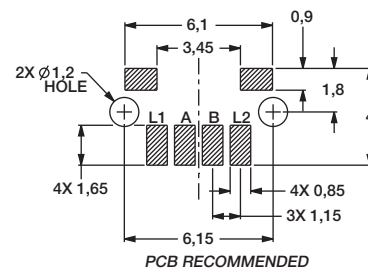
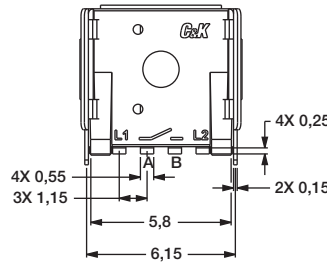
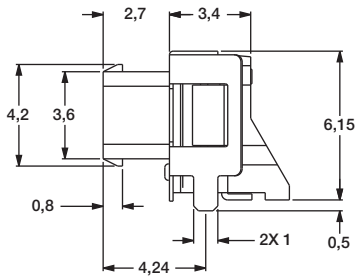
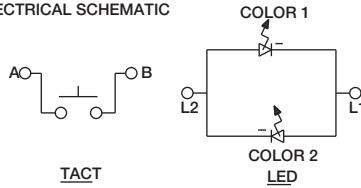

TAPE & REEL: 500 PIECES

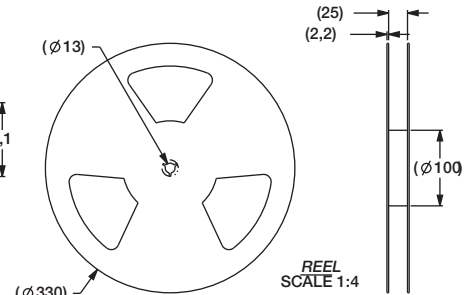
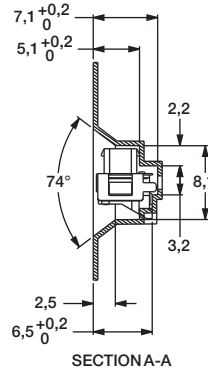
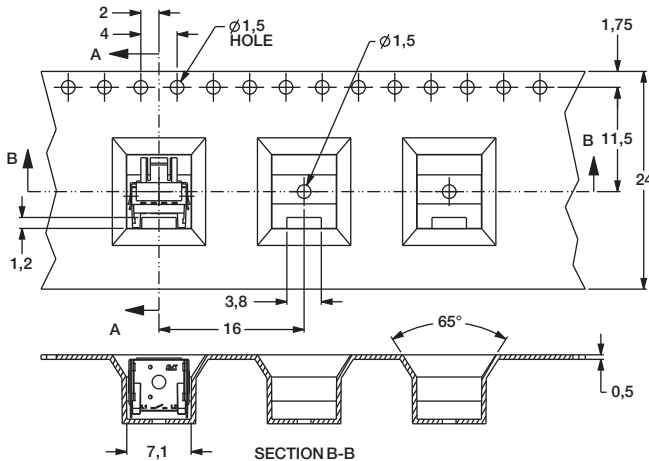

ITS Series Illuminated Tact Switch

FORCE

| OPTION CODE | FORCE |
|-------------|---|
| S | Standard 160 gf - V1, V2, V3, R1, R2 options 220 gf - R3 option |

CAPS

Use the individual ordering code for each cap



399EA0000
Round cap, clear

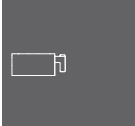
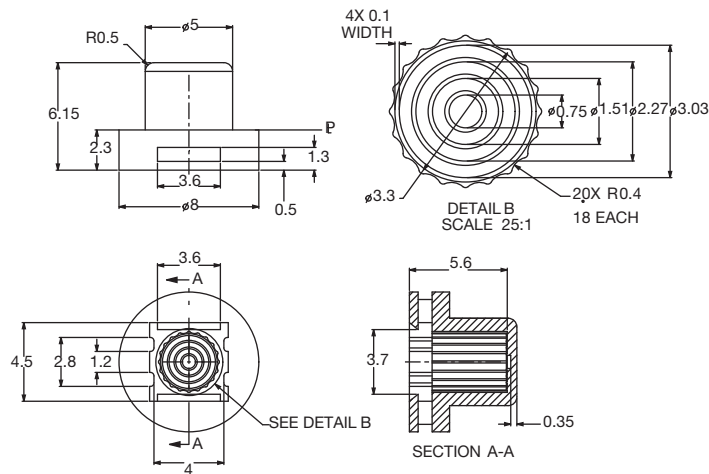
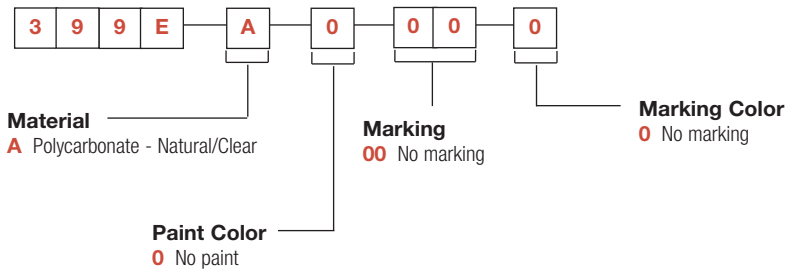

B

Tactile Switches

ITS Series Illuminated Tact Switch

CAPS



400EA0000

Natural/clear



400EB0000

Translucent white, flat edge



400ECA01E

Matte silver paint laser etch, flat edge

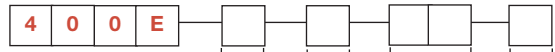

Material

- A** Natural/Clear - polycarbonate
- B** Translucent white - polycarbonate
- C** Silver paint laser etch - polycarbonate

Paint Color

- 0** No paint
- A** Matte silver

Laser Etch Marking

- 00** No marking
- 01** Power On/Off
- 04** Arrow right
- 05** Arrow left
- 06** Arrow up
- 07** Arrow down
- 09** Power
- 33** Arrow up (fill)
- 34** Arrow down (fill)
- 97** I/O



Marking Color

- 0** No marking
- E** Laser etch (painted caps only)

Tactile Switches

B



ITSXXFR1ST &
400ECA01E cap

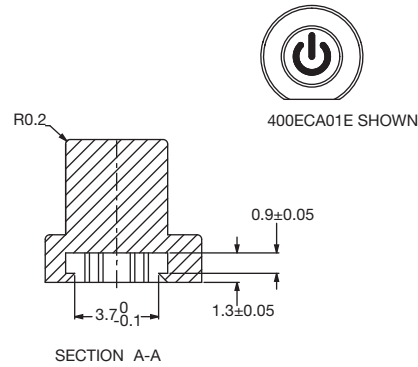
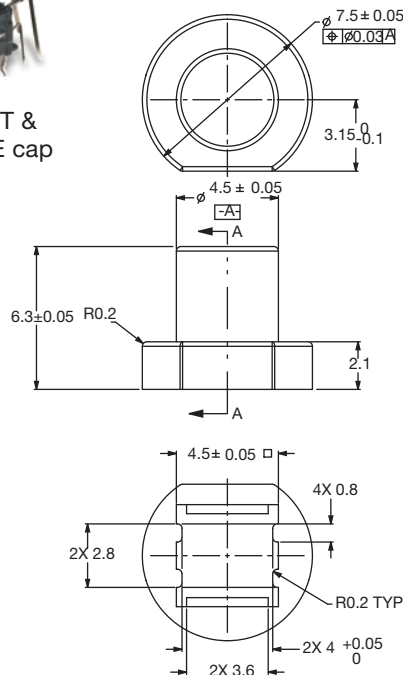

400E cap dimensions shown are "as molded" (no paint).

ITS Series Illuminated Tact Switch

CAPS



401ECA06E

Matte silver paint, laser etch,
tall oval

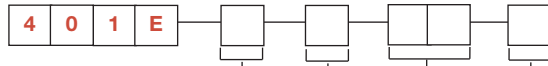

Material

- A** Natural/clear - polycarbonate
- B** Translucent white - polycarbonate
- C** Paint laser etch - polycarbonate

Paint Color

- 0** No paint
- A** Matte silver

**Laser Etch
Marking**

- 00** No marking
- 06** Arrow up
- 07** Arrow down
- 33** Arrow up (fill)
- 34** Arrow down (fill)

Marking Color

- 0** No marking
- E** Laser etch (painted caps only)

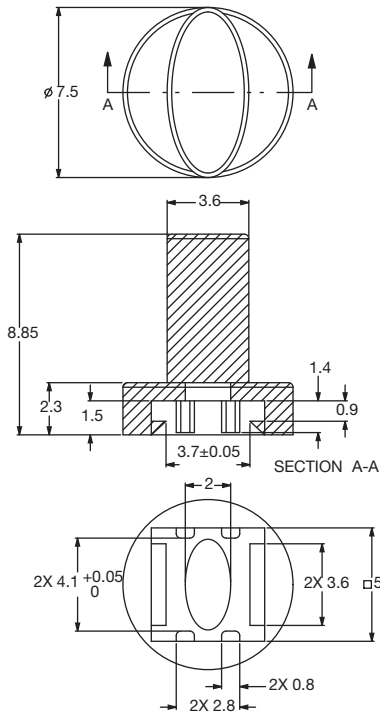

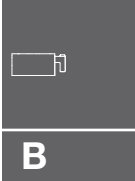

401E cap dimensions shown are "as molded" (no paint).



Tactile Switches

Navigation Switches

Product Selection Guide

| | | |
|-----------------------------------|---|---|
| Navigation |  |  |
| Series | TSW | CS |
| Number of directions | 3 7 | 4 |
| Size on PCB L x W (mm) | ø 21 ø 34,4 | 40 x 40 |
| Total Height (mm) | 3,5 6,0 | 58 |
| Actuation Force (N) | 2,2 to 3,0 scanning and select, 0.5N cm rotation | 4,9N |
| Contact Type | Silver | NA |
| Max. Voltage (VDC) | 10 | 12 |
| Max. Switching Power (A) | 0.001 | 0.2 |
| Life Cycles/ per way | 1,000,000 | 10,000 |
| Sealing | Not sealed | Not sealed |
| Page Number | C-3 | C-6 |



Navigation

TSW Series 3 or 7 Function Tact and Scroll Wheel

Features/Benefits

- Compact and slim
- Multiple function in one component (rotary, select)
- Easy installation
- Through hole termination
- Integrated decoration (B type)

Typical Applications

- Remote controls
- Desk phones
- Keyboards
- Printers
- Entertainment systems
- White goods



Operation Characteristics

OPERATING FORCE: See chart below
24 detent - 12 pulses/360°

Specifications

INITIAL CONTACT RESISTANCE: Max. 300mΩ
INSULATION RESISTANCE: Min. 100 MΩ (100 VDC)
RATING: 1mA 10 VDC
LIFE CYCLE: See chart below
OPERATING FREQUENCY:
Rotation - Max. 30 operations per minute
Push - Max. 120 operations per minute
Depression - Max. 300 gf

Environmental

OPERATING TEMPERATURE: 0°C / 40°C
STORAGE TEMPERATURE: -40°C / 70°C
VIBRATION RESISTANCE: 10 ~ 55 Hz, displacement 0.75mm (p-p)
SHOCK RESISTANCE: Destruction 1,000 m/s² (approx. 100G) max.
WAVE SOLDERING: Max. 260°C for 5 seconds
HAND SOLDERING: Max. 260°C for 5 seconds

| Designation | Number of Circuits | Rotation Actuation Force | Push Actuation Force | Cycle Life Rotation (per direction) | Cycle Life Push |
|-------------|--------------------|--------------------------|----------------------|-------------------------------------|-----------------|
| TSWA | 3 | Max. 60g - cm | 220g ± 50g | 1,000K cycles | 1,000K cycles |
| TSWB | 5 | Max. 50g - cm | Max 300g | 1,000K cycles | 1,000K cycles |

| Part Number | Description | Tray | Box |
|-------------------|---|------|-----|
| TSWA-3N-C LFS | Base switch with jog and select, no decoration | 80 | 160 |
| TSWA-3N-CB11 LFS | Base switch with jog and select, white central button, white dial | 65 | 130 |
| TSWA-3N-CD23 LFS | Base switch with jog and select, black central button, grey dial | 30 | 60 |
| TSWB-3N-CB111 LFS | Central select with jog and 4 directions, white central button, dial & direction ring | 30 | 60 |
| TSWB-3N-CB222 LFS | Central select with jog and 4 directions, black central button, dial & direction ring | 30 | 60 |

TSWA-3N-C LFS

Base switch with jog and select, no decoration

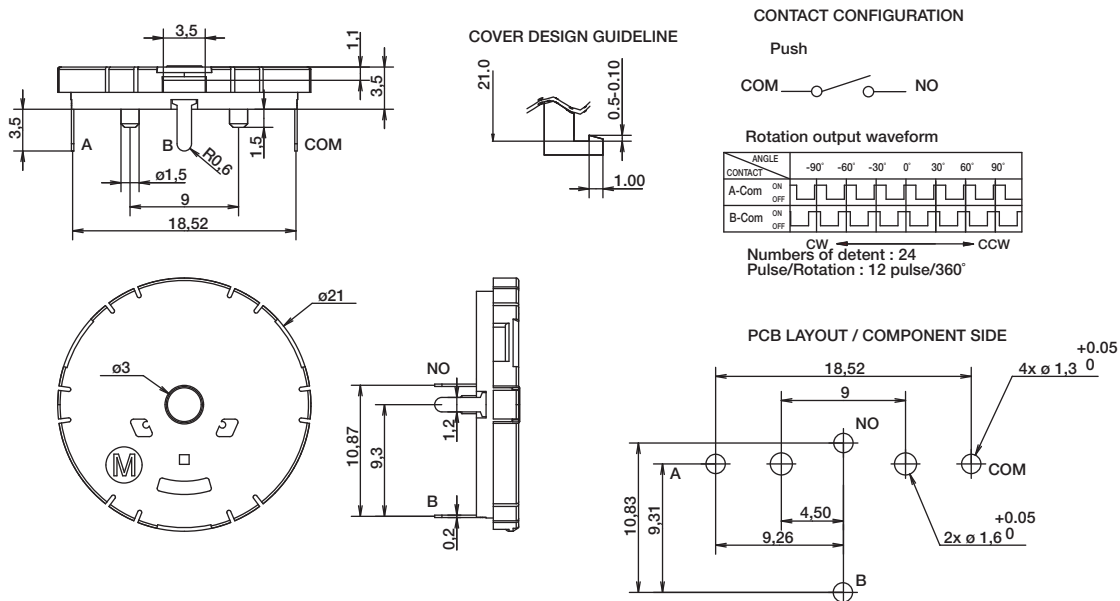

Dimensions are shown: mm
Specifications and dimensions subject to change



TSW Series

3 or 7 Function Tact and Scroll Wheel

TSWA-3N-CB11 LFS Base switch with jog and select, white central button, white dial

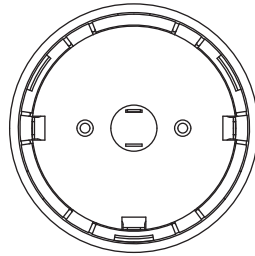

CONTACT CONFIGURATION

Push



Rotation output waveform

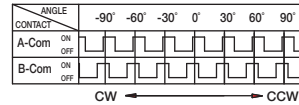

Numbers of detent : 24

Pulse/Rotation : 12 pulse/360°

PCB LAYOUT / COMPONENT SIDE

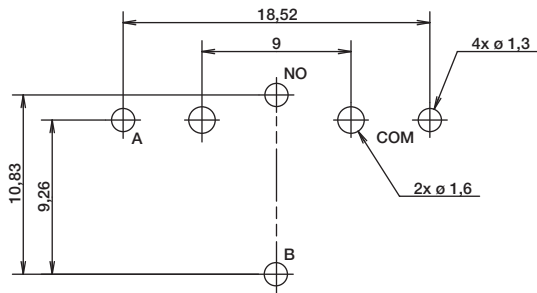

Navigation

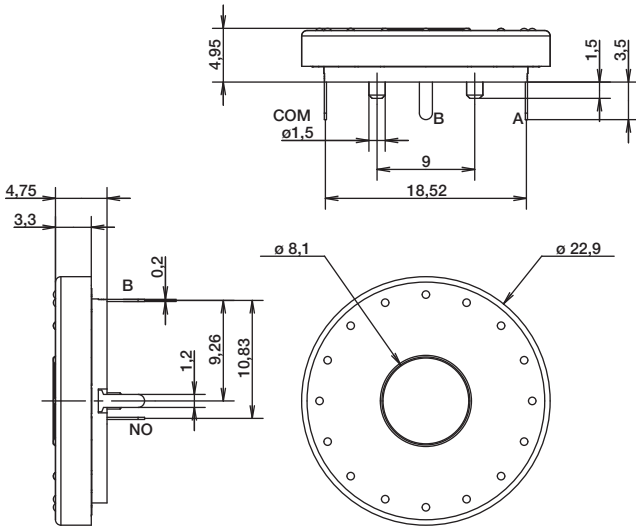

TSWA-3N-CD23 LFS Base switch with jog and select, black central button, grey dial

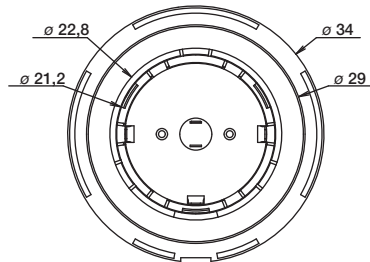
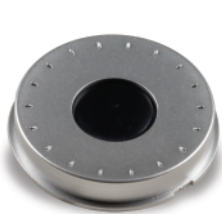

CONTACT CONFIGURATION

Push



Rotation output waveform

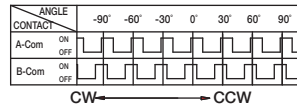

Numbers of detent : 24

Pulse/Rotation : 12 pulse/360°

PCB LAYOUT / COMPONENT SIDE

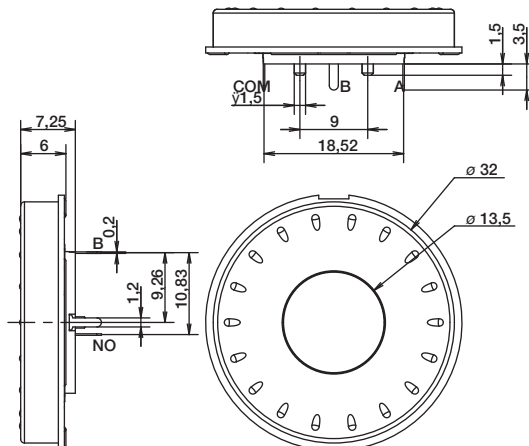
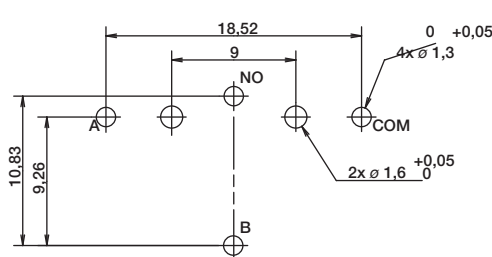

First Angle Projection

Dimensions are shown: mm
Specifications and dimensions subject to change



TSW Series

3 or 7 Function Tact and Scroll Wheel

TSWB-3N-CB111 LFS
TSWB-3N-CB222 LFS

Central select with jog and 4 directions, white central button, dial & direction ring
 Central select with jog and 4 directions, black central button, dial & direction ring

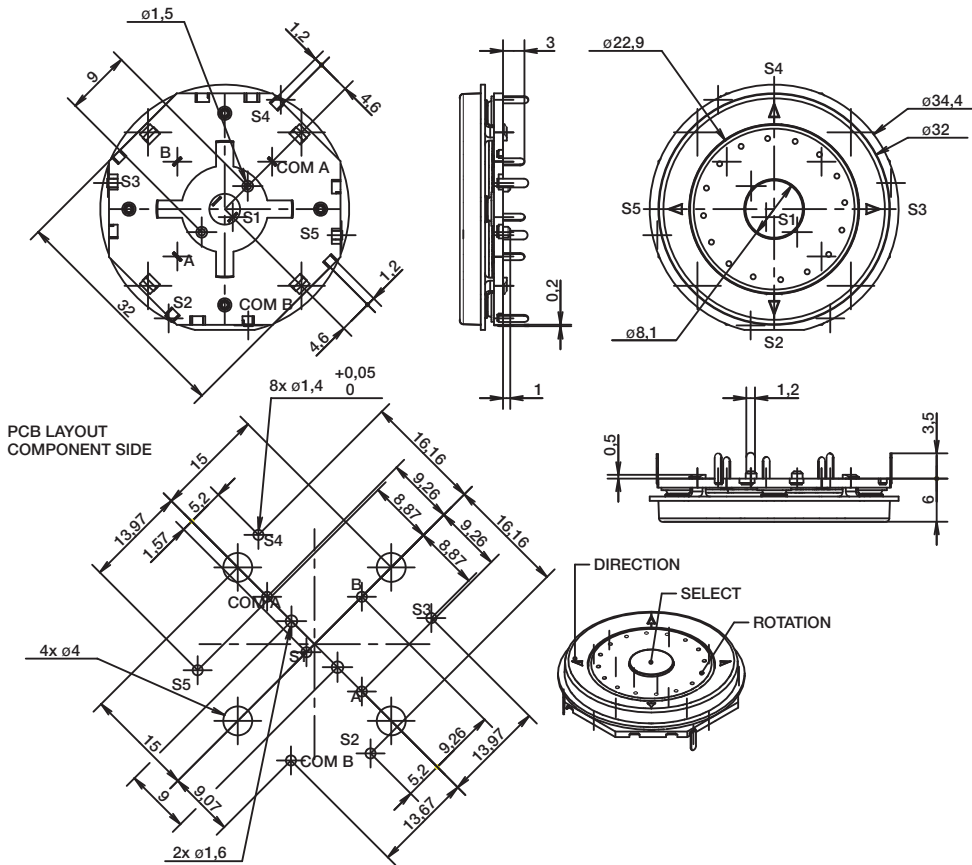

ELECTRICAL FUNCTION

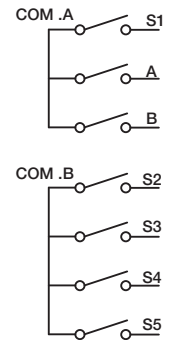

Rotational Output Waveform

| ANGLE | -90° | -60° | -30° | 0° | 30° | 60° | 90° |
|---------|------|------|------|-----|-----|-----|-----|
| CONTACT | | | | | | | |
| A-COM A | ON | OFF | ON | OFF | ON | OFF | ON |
| B-COM A | ON | OFF | ON | OFF | ON | OFF | ON |

CW ← → CCW

Numbers of detent : 24

Pulse/Rotation : 12 pulse/360°



C

Navigation

CS-41001E Series 4-way Adjustable Direction Switch



Features/Benefits

- Designed for mirror control
- Wire harness and connector easy to customize
- 4-way adjustable directions

Typical Applications

- Automotive
- Industrial

Specifications

CONTACT RATING: 0.2 A @ 12 VDC
 OPERATING LIFE: 10,000 cycles
 INSULATION RESISTANCE: 10 M Ω min. @ 500 VDC
 DIELECTRIC STRENGTH: 500 V AC
 OPERATING TEMPERATURE: -40°C to +90°C
 OPERATING FORCE: L- OFF, R-OFF; 200 \pm 100 gf
 OFF-L, OFF-R; 400 \pm 200 gf
 4 Direction; 500 \pm 200 gf

Materials

KNOB: ABS
 COVER: ABS
 TERMINAL: Brass, tin plated

NOTE: Specifications and materials listed above are for switches with standard options. For information on specific and custom switches, consult Customer Service Center.



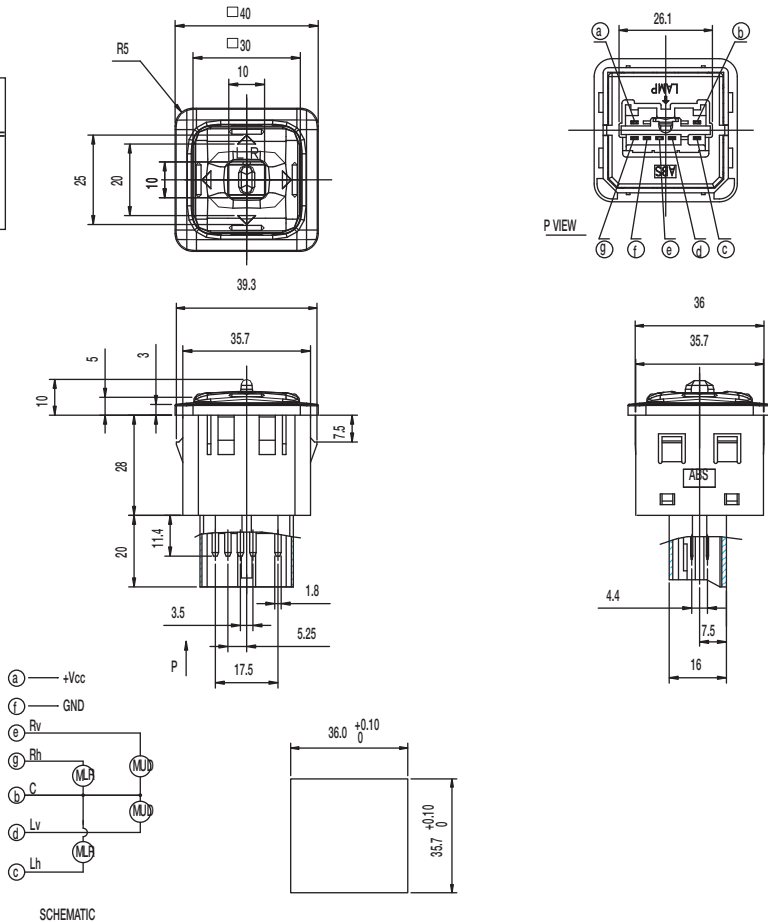

Navigation





| PART NUMBER | PACKAGING |
|-------------------|------------|
| CS-41001-E | 256 pieces |

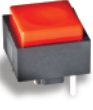

Key Switches

Product Selection Guide

| Key Switches |  |  |  |  |  |
|-------------------------------|---|---|--|---|---|
| Series | K6 | K12S | K12 | PVA | PVB |
| Size (mm) L x W x H | 7,4 x 10,9 x 8,4 | 12 x 11,6 x 9,1 | 12 x 12 x 11 | 9,2 x 10 x 13,5 | PVB4: 9,4 x 9 x 12,5 PVB6: 9,85 x 8,6 x 12,5 |
| Poles/Throws | SPST momentary | SPST / DPST momentary | SPST 2 x SPST momentary | DPST / DPDT momentary or push-on/push off | SPDT PVB4 DPDT PVB6 |
| Maximum Load | 30 V / 100 mA | 30 V / 100 mA | 30 V / 100 mA | 32 V / 100 mA | 14 V / 100 mA or 200 mA |
| Operating Force | 2 N; 3 N; 5 N | 3 N; 5 N; 6 N 9 N; 4/8 N; 6/12 N | 1,5 N; 2,5 N; 3,5 N; 5 N 3,5/7 N; 6/12 N | 1,2 N; 1,7 N; 3,5 N | 3 N |
| Travel (standard) | 1,5 mm | 1,5 mm | 1 mm, 1,5 mm, 2 mm | Mom. 2,4 mm Push-push 2,4/1,5mm | Mom. 2,3 mm Push-push 2,3/1,5mm |
| Life Cycle | 200,000 | 1,000,000 | 1,000,000 | 100,000 | PVB4: 100,000 PVB6: 30,000 |
| Sealed | | IP40/IP67 | K12C only | | |
| Illumination | • | • | • | | |
| Termination | SMT/ Thru-hole | SMT | Thru-hole | Thru-hole | SMT / Thru-hole |
| Page Number | D-3 | D-6 | D-9 | D-15 | D-18 |

| Key Switches |  |  |  |  |  |
|-------------------------------|---|---|--|---|---|
| Series | D6 | KS | Digitast | ED / EDM | KBD |
| Size (mm) L x W x H | 12 x 11,4 x 14,5 | 12,4 x 12,4 x 9,9 | 17,1x12,3 x 14,3 | 12,7 x 11,3 x 1,2 | 15,6 x 15,6 x 15 |
| Poles/Throws | SPST momentary | SPST SPDT | SPDT momentary or push-on/push off | SPST momentary | SPST momentary |
| Maximum Load | 32 V/100 mA* | 50 V/25 mA | 24 V / 10 mA | 100 V/100 mA | 12 VDC /10 mA |
| Operating Force | 1,3 N 2,75 N | | 1,5 N | 2,4 N to 6,5N | 45gf / 55gf / 60gf 0,4N / 0,5N / 0,6N |
| Travel (standard) | 1 mm 1.10 mm | 0,71 mm | 3 mm | 0,3 mm | 1,5 ~ 2 mm |
| Life Cycle | 250,000 | 100,000 | 5,000,000 | 1,000,000 | 50,000,000 |
| Sealed | | | | • | • |
| Illumination | | | • | | |
| Termination | Thru-hole | Thru-hole | Thru-hole | Thru-hole/SMT | Thru-hole |
| Page Number | D-23 | D-26 | D-29 | D-32 | D-34 |

* Maximum value are for voltage and current separately

Dimensions are shown: mm
Specifications and dimensions subject to change



D

K6 Miniature Key Switches

Features/Benefits

- Excellent tactile feel
- Wide variety of LED's, travel and actuation forces
- Designed for low-level switching
- Detector version available
- RoHS compliant

Typical Applications

- Automotive
- Industrial electronics
- Computers and network equipment



Construction

FUNCTION: momentary action
 CONTACT ARRANGEMENT: 1 make contact = SPST, N.O.
 DISTANCE BETWEEN BUTTON CENTERS:
 min. 7,5 and 11,8 (0.295 and 0.465)
 TERMINALS: Snap-in pins, tinned
 MOUNTING: Soldered by PC pins, locating pins
 PC board thickness: 1,5 (0.0591)

Mechanical

TOTAL TRAVEL/SWITCHING TRAVEL: 1,5/0,9 (0.059/0.035)
 PROTECTION CLASS: IP 40 according to DIN/IEC 529

- 1) Voltage rise: 300 V/s
 2) According to DIN 41640; IEC 512-2
 3) Higher values upon request

Packaging

THT: bulk in boxes of 500 pieces
 SMT: bulk in boxes of 500 pieces
 reels of 500 pieces (with LED) or 750 pieces (without LED)

Electrical

SWITCHING POWER MIN./MAX.: 0.02 mW / 3 W DC
 SWITCHING VOLTAGE MIN./MAX.: 2 V DC / 30 V DC
 SWITCHING CURRENT MIN./MAX.: 10 mA / 100 mA DC
 DIELECTRIC STRENGTH (50 Hz)¹⁾²⁾: ≥ 300 V
 OPERATING LIFE: ≥ 2 x 10⁵ operations ³⁾
 ≥ 1 X 10⁵ operations for SMT version
 CONTACT RESISTANCE: Initial ≤ 50 mΩ
 INSULATION RESISTANCE: ≥ 10¹⁰ Ω
 BOUNCE TIME: ≤ 1 ms
 Operating speed 100 mm/s (3.94/s)

Environmental

OPERATING TEMPERATURE: -40°C to 85°C.
 STORAGE TEMPERATURE: -40°C to 95°C.

Process

SOLDERABILITY:
 THT: wave soldering, compatible with lead free soldering profile
 Hand soldering, 350°C for 3s
 SMT: not compatible with lead free reflow profile
 245°C for 5s

How To Order

Our easy build-a-switch concept allows you to mix and match options to create the switch you need. To order, select desired option from each category and place it in the appropriate box.

Note: Some of the configurations may not be available or could require some development.

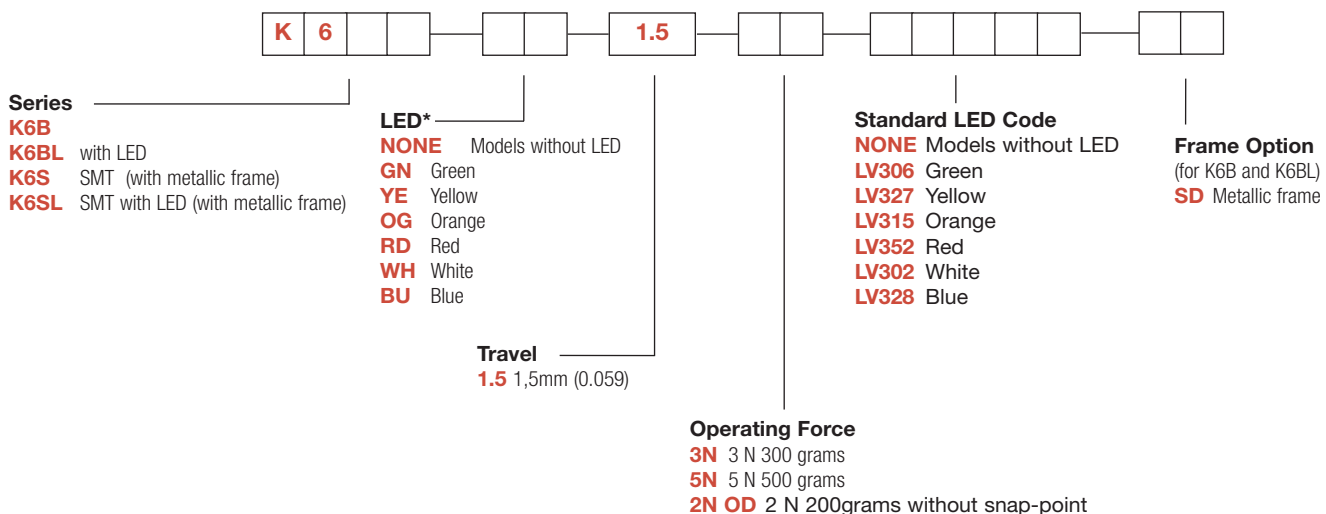

* Additional LED colors available by request.

K6 Miniature Key Switches

SERIES

K6B WITHOUT LED

K6BL WITH LED

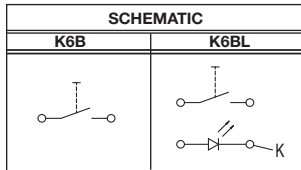
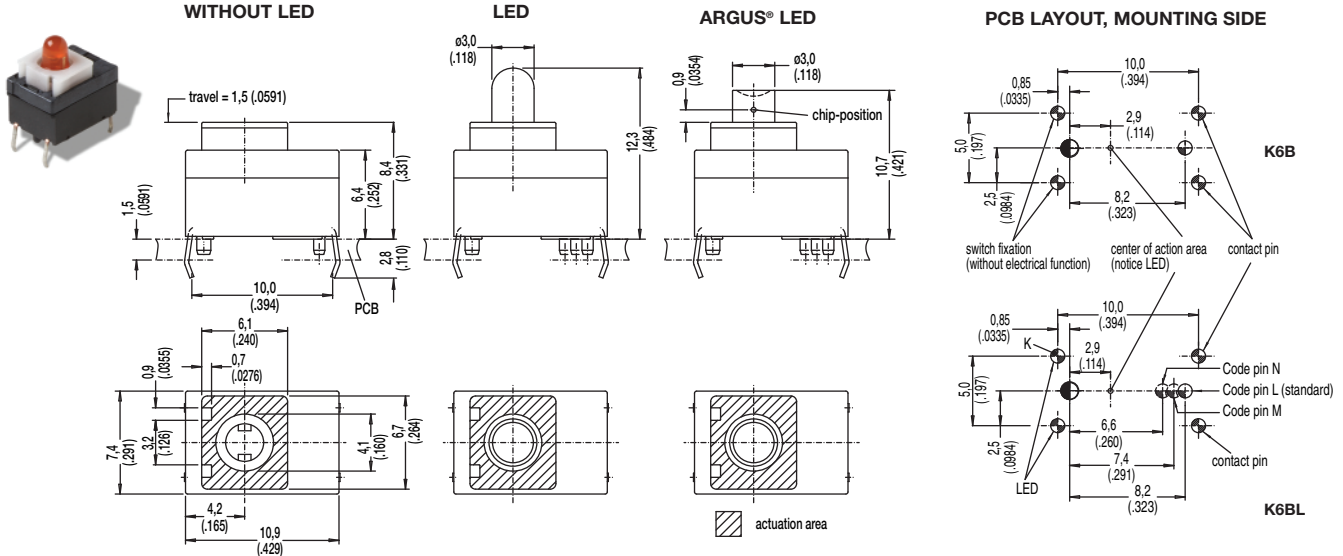

| Hole | Ø | Without LED | With LED | Description | Terminal Section | Surface |
|------|---------------------------|-------------|----------|-----------------|------------------------------|---------|
| | 1,2+0,1 (.0471+.00349) | 1x | 1x | center hole | | |
| | 0,9+0,1 (.0354+.00349) | 1x | 1x | code (L,M,N) | | |
| | 1,0+0,1 (.0354+.00349) | | 2x | LED switch | 0,6 x 0,3 (.0236 x .0118) | SnPb |
| | | 4x | 2x | | | |

K6S WITHOUT LED

K6SL WITH LED



D

Key Switches

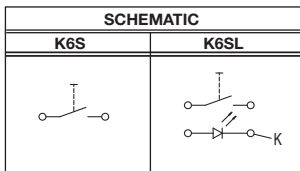
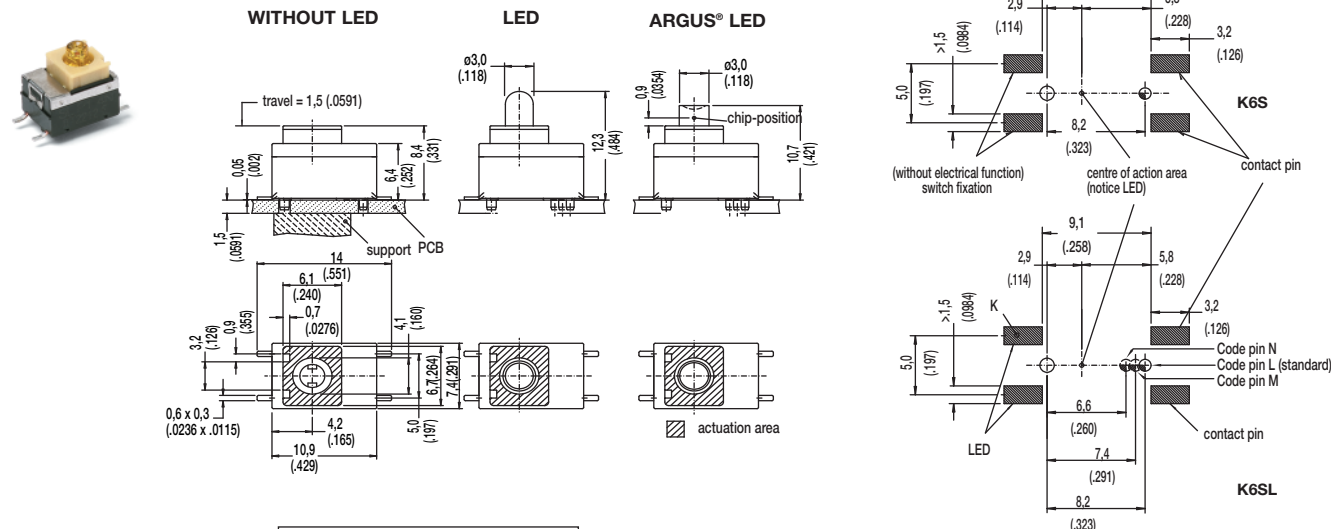

| Hole | Ø | Without LED | With LED | Description |
|------|---------------------------|-------------|----------|-----------------|
| | 1,2+0,1 (.0471+.00349) | 1x | 1x | center hole |
| | 0,9+0,1 (.0354+.00349) | 1x | 1x | code (L,M,N) |



Dimensions are shown: mm
Specifications and dimensions subject to change



K6 Miniature Key Switches

LED

| OPTION CODE | COLOR |
|-------------|--------------------|
| NONE | Models without LED |
| GN | Green |
| YE | Yellow |
| OG | Orange |
| RD | Red |
| WH | White |
| BU | Blue |

| STANDARD LED CODE | COLOR |
|-------------------|--------------------|
| NONE | Models without LED |
| LV306 | Green |
| LV327 | Yellow |
| LV315 | Orange |
| LV352 | Red |
| LV302 | White |
| LV328 | Blue |

Additional LED colors available by request

TRAVEL

1.5 1.5 MM

OPERATING FORCE

| OPTION CODE | OPERATING FORCE |
|--------------|------------------------------|
| 3N | 3 N, 300 g |
| 5N | 5 N, 500 g |
| 2N OD | 2 N, 200g without snap-point |

FRAME OPTION

SD METALLIC FRAME (OPTION FOR K6B AND K6BL)

NOTE: K6S and K6SL are equipped with metallic frame (SD not specified)



D

Key Switches

K12S

High Performance SMT Key Switches



Features/Benefits

- Harsh environment applications - IP67
- Compatible with SMT lead free soldering process
- Illuminated
- Excellent tactile feel
- High reliability / long life
- DPST and detect versions available
- RoHS compliant

Typical Applications

- Automotive
- Off-road transportation
- Motorcycles
- Industrial
- Medical
- Network
- Joysticks

Construction:

FUNCTION: Momentary
 CONTACT ARRANGEMENT: SPST or DPST
 CONTACT TYPE: NO or NC
 TERMINALS: SMT

Mechanical

TOTAL TRAVEL: 1,5 mm
 OPERATING FORCE: 3N; 5N; 6N; 9N 4/8 N; 6/12 N
 SEALING: IP40 or IP67

Packaging

Reels of 900 pieces

Electrical

SWITCHING POWER MIN./MAX.: 0.02mW/3 W DC
 SWITCHING VOLTAGE MIN./MAX.: 2 V / 30 V DC
 SWITCHING CURRENT MIN./MAX.: 10 mA /100 mA DC
 DIELECTRIC STRENGTH: > 300 V RMS
 OPERATING LIFE: > 10⁶ operations (F<5N) / 10⁵ operations (F≥5N)
 CONTACT RESISTANCE: Initial < 100mΩ - After test < 250mΩ
 INSULATION RESISTANCE: >10⁹Ω
 BOUNCE TIME: < 10 ms

Environmental

OPERATING TEMPERATURE: -40°C to 85°C.
 STORAGE TEMPERATURE: -40°C to 95°C.
 RoHS compliant and Halogen free.

Process

SOLDERABILITY: Lead free soldering compatible.

How To Order

Our easy build-a-switch concept allows you to mix and match options to create the switch you need. To order, select desired option from each category and place it in the appropriate box.



D

Key Switches



Sub-Series

- A IP40 with peg
- B IP67 with peg
- C IP40 without peg
- D IP67 without peg

Option

- S SPST version
- L LED version (SPST)
- D DPST version

LED Color

- NONE No LED
- YE0 Yellow
- RD0 Red
- GN0 Green
- OR0 Orange
- WH0 White
- AM0 Amber

Operating Force

- 3N 3 N
- 5N 5 N
- 6N 6 N
- 9N 9 N
- 4/8N 4/8 N (double step actuation)
- 6/12N 6/12 N (double step actuation)

Travel

- 1.5 1.5 mm

Contact Arrangement

- O Normally open (SPST)
- C Normally closed (SPST)
- OO 2 Normally open (DPST)
- CC 2 Normally closed (DPST)
- OC 1 Normally open
- 1 Normally closed (DPST)

LFTX

Lead free, RoHS terminals tin plated Translucent button



Dimensions are shown: mm
 Specifications and dimensions subject to change

K12S High Performance SMT Key Switches

K12SA/K12SC IP40 with peg / IP40 without peg

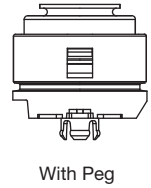
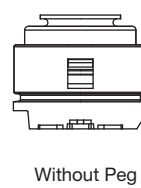
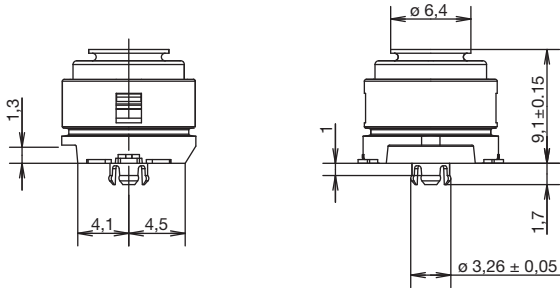
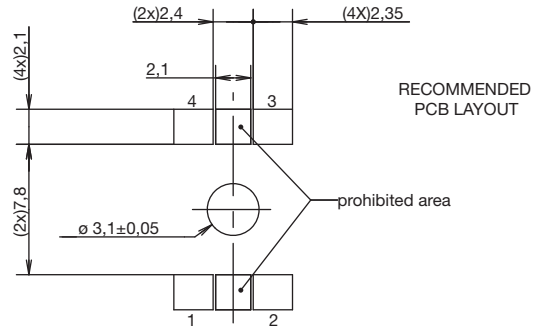
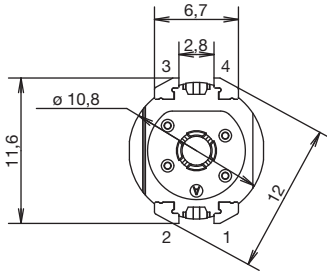

K12SB / K12SD IP67 with peg / IP67 without peg

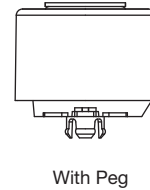
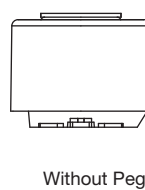
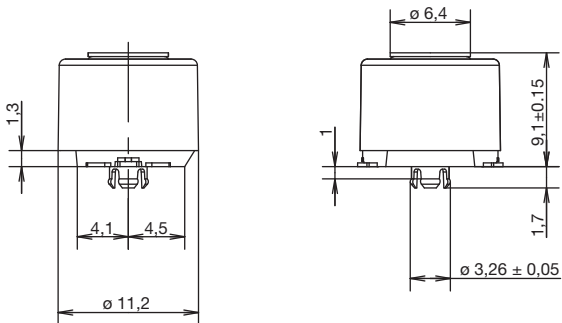
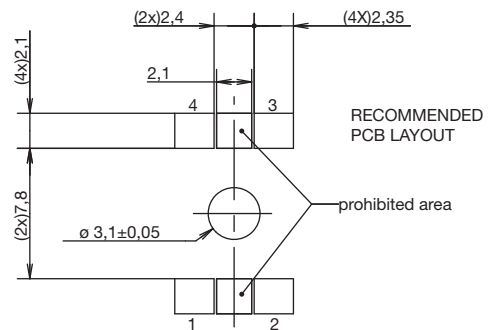
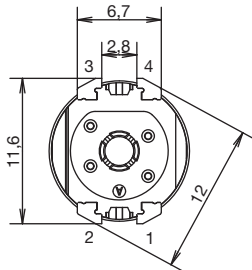

Dimensions are shown: mm
Specifications and dimensions subject to change

K12S

High Performance SMT Key Switches

OPTION

S SPST version

Single NO

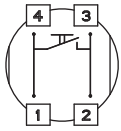

Single NC

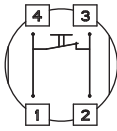

L LED version

Single NO + LED

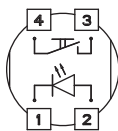

Single NC + LED

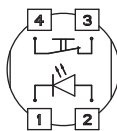

D DPST version

Double NO

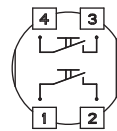

Double NC

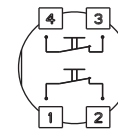

LED COLOR

| OPTION CODE | LED COLOR |
|-------------|-----------|
| | No LED |
| YE0 | Yellow |
| RD0 | Red |
| GN0 | Green |
| OR0 | Orange |
| WH0 | White |
| AM0 | Amber |

TRAVEL

1.5 1.5 mm

OPERATING FORCE

| OPTION CODE | OPERATING FORCE |
|--------------|-------------------------------|
| 3N | 3N |
| 5N | 5N |
| 6N | 6N |
| 9N | 9N |
| 4/8N | 4/8N (double step actuation) |
| 6/12N | 6/12N (double step actuation) |

CONTACT ARRANGEMENT

- O** Normally open (SPST and LED versions)
- C** Normally closed (SPST and LED versions)
- OO** 2 Normally open (DPST version)

- CC** 2 Normally closed (DPST version)
- OC⁽¹⁾** 1 Normally open/ 1 Normally closed (DPST)

⁽¹⁾ Please contact Technical support for this configuration using the "Ask a Specialist" option on the K12S product web page.

TAPE AND REEL

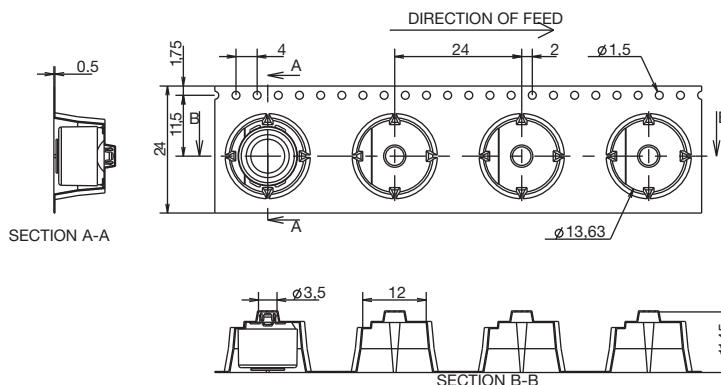

First Angle Projection

Dimensions are shown: mm
Specifications and dimensions subject to change



D

Key Switches

K12 High Performance Key Switches

Features/Benefits

- **Excellent tactile feel**
- **Wide choice of LED colors, travel and actuator forces**
- **High reliability / long life**
- **Sealed version available**
- **Designed for low-level switching**
- **Double stroke version available**
- **Detector version available**

Typical Applications

- **Automotive**
- **Off-road transportation**
- **Industrial electronics**
- **Computers & network equipment**
- **Joysticks**



Construction:

FUNCTION: momentary
 DISTANCE BETWEEN BUTTON CENTERS:
 min. 11 (0.433) K12C = 13 (0.512)
 TERMINALS: PC pins, tinned
 MOUNTING: Locating pins; K12G and K12P additionally
 with snap-in housing

Mechanical

TOTAL TRAVEL: 1 mm, 1.5 mm, 2 mm
 SWITCHING TRAVEL: 0,6 mm*
 OPERATING FORCE: 1.5 N OD without snap-point as detector
 switch, 2.5 N, 3.5 N, 5 N, 3.5/7 N, 6/12 N. Additional
 operating force 7N, 9N and 20N, available on request.
 PROTECTION CLASS: K12C IP 67 (dust tight, protected against
 the effects of immersion in water; other versions IP 40)

* Additional switching travel (with pre-travel) available by request.

Packaging

Bulk in boxes of 250 pieces (version C or GO) or
 300 pieces (version A, AL, P or PL)

Electrical

SWITCHING POWER MIN./MAX.: 0.02mW/3 W
 SWITCHING VOLTAGE MIN./MAX.: 2 V DC / 30 V DC
 SWITCHING CURRENT MIN./MAX.: 10 mA /100 mA
 DIELECTRIC STRENGTH (50 Hz, 1 min): ≥ 500 V
 OPERATING LIFE with max. switching power: ≥ 10⁶ operations
 K12G & K12GO; operating life of second switch 5 x 10⁴ operations,
 operating life K12C and version with more than 6N (7N, 9N 20N)
 please consult factory.
 CONTACT RESISTANCE: Initial ≤ 50 mΩ
 INSULATION RESISTANCE: ≥ 10¹⁰ Ω
 BOUNCE TIME: ≤ 1 ms
 Operating speed 100 mm/s (3.94/s)

Environmental

OPERATING TEMPERATURE: -40°C to 85°C.
 STORAGE TEMPERATURE: -40°C to 95°C.

Process

SOLDERABILITY:
 Wave soldering, compatible with lead free soldering profile
 Hand soldering, 350°C

How To Order

Our easy build-a-switch concept allows you to mix and match options to create the switch you need. To order, select desired option from each category and place it in the appropriate box.

Note: Some of the configurations may not be available or could require some development.

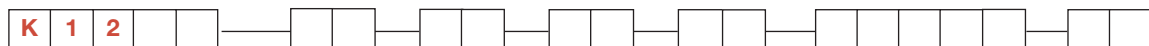

Series

- K12A** No snap-in pegs
- K12AL** No snap-in pegs with central LED
- K12P** With snap-in pegs
- K12PL** With central LED
- K12C** Sealed contact with rubber cap (IP 67)
- K12GO** Two-step switch

Cap Color

- NONE** version with LED, version C
- BK** Black cap - No LED
- YE** Yellow cap - No LED
- RD** Red cap - No LED
- GY** Gray cap - No LED

LED Color

- NONE** No LED
- GN** Green
- YE** Yellow
- OG** Orange
- RD** Red
- WH** White
- BU** Blue

Travel*

- 1** 1 mm (0.039)
- 1.5** 1.5 mm (0.059)
- 2** 2 mm (0.079)

Operating Force***

- 1.5N OD** 1.5 N without snap-point
- 2.5N** 2.5 N
- 3.5N** 3.5 N
- 5N** 5 N
- 3.5/7N** 3.5/7 N**
- 6/12N** 6/12 N**

Standard LED Code

- NONE** No LED
- LV306** Green
- LV327** Yellow
- LV315** Orange
- LV352** Red
- LV302** White
- LV328** Blue

Contact

- Arrangement**
- NONE** SPST NO (STD)
- 1R** SPST NC (Special request)

* K12C – 1mm MAX
 K12 with LED – 1.5 mm MAX
 ** K12G & K12GO version only
 *** Additional operating force: 7N, 9N available on request



*Dimensions are shown: mm
 Specifications and dimensions subject to change*



K12 High Performance Key Switches

SERIES

K12A without snap in

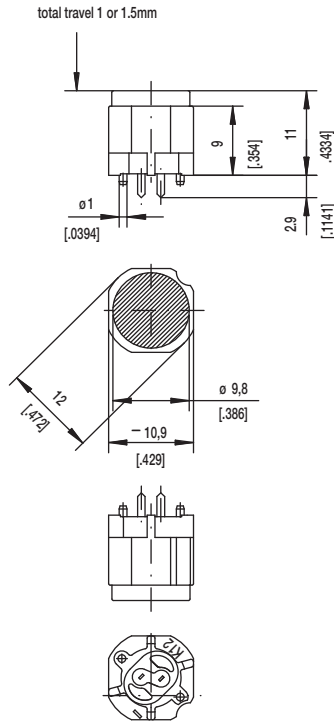

PCB LAYOUT, MOUNTING SIDE

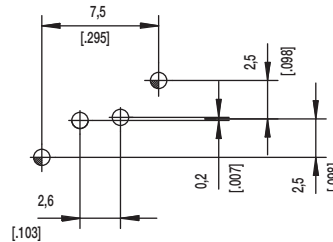

K12AL

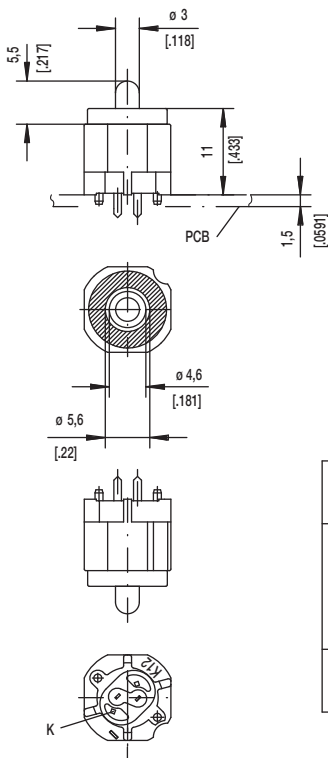

PCB LAYOUT, MOUNTING SIDE

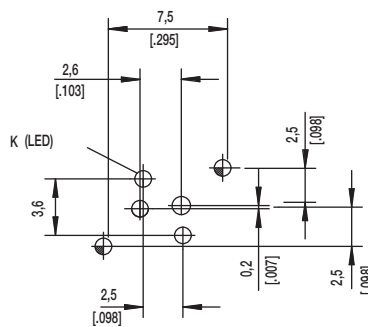

| | | | | | | |
|------|----------------|---------|----------|-------------|--------------------------------------|---------|
| | $1,1^{+0,05}$ | 2x | 2x | center hole | | |
| | $0,9 \pm 0,05$ | | 2x | LED | $\varnothing 0,5 (.020)$ | Sn |
| | | 2x | 2x | switch | $0,7 \times 0,2 (.028 \times 0.081)$ | Sn |
| Hole | \varnothing | Without | with LED | Description | Terminal Section | Surface |



Key Switches



First Angle
Projection

Dimensions are shown: mm
Specifications and dimensions subject to change

C&K

K12 High Performance Key Switches

SERIES

K12P with snap in

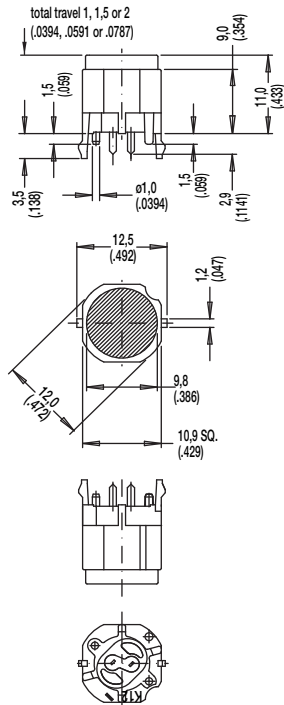

PCB LAYOUT, MOUNTING SIDE

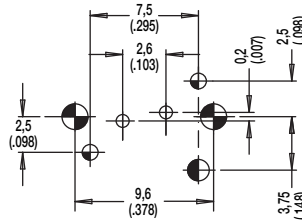

center of actuation area (notice LED)



| Hole | Ø | Without LED | Description | Terminal Section | Surface |
|------|------------|-------------|---------------------|-------------------------|---------|
| | 1,7 (.069) | 2x | snap-in | | |
| | 1,6 (.062) | 1x | coding hole (L,M,N) | | |
| | 1,1 (.043) | 2x | center hole | | Sn |
| | 0,9 (.035) | 2x | switch | 0.7 x 0.2 (.028 x .081) | Sn |

K12PL

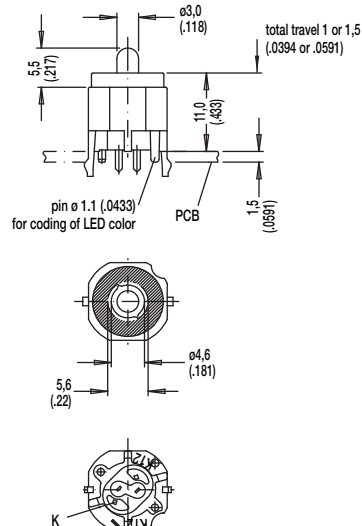

PCB LAYOUT, MOUNTING SIDE

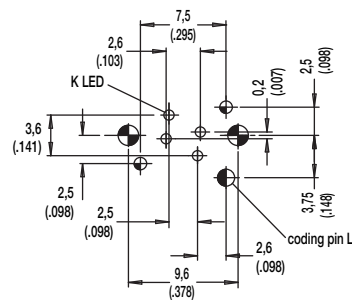

center of actuation area (notice LED)



| Hole | Ø | Without LED | Description | Terminal Section | Surface |
|------|------------|-------------|---------------------|-------------------------|---------|
| | 1,7 (.069) | 2x | snap-in | | |
| | 1,6 (.062) | 1x | coding hole (L,M,N) | | |
| | 1,1 (.043) | 2x | center hole | | Sn |
| | 0,9 (.035) | 2x | LED | m0.5 (.020) | Sn |
| | | 2x | switch | 0.7 x 0.2 (.028 x .081) | |



Dimensions are shown: mm
Specifications and dimensions subject to change

K12 High Performance Key Switches

SERIES 

K12C SEALED CONTACT WITH RUBBER CAP (IP 67)

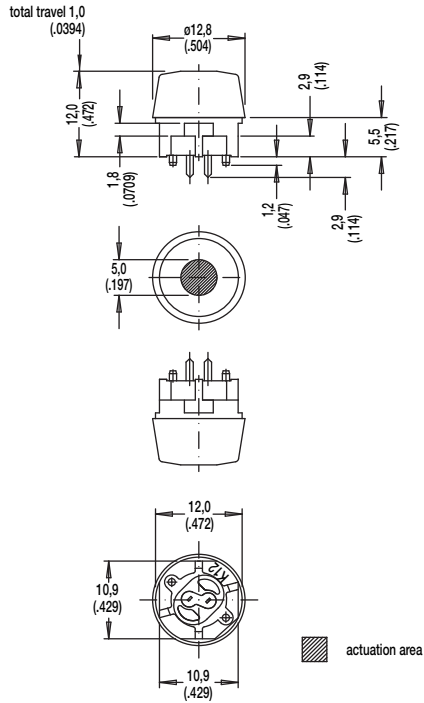

PCB LAYOUT, MOUNTING SIDE

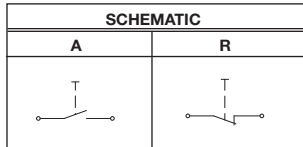
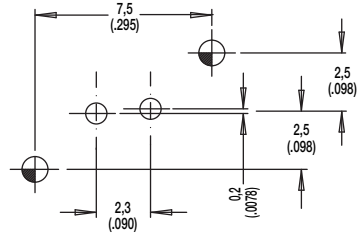

| Hole | Ø | Without LED | Description | Terminal Section | Surface |
|------|------------|-------------|-------------|---------------------------|---------|
| | 1,1 (.043) | 2x | center hole | | |
| | 0,9 (.035) | 2x | switch | 0.7 x 0.2 (.0275 x .0787) | Sn |



Key Switches



First Angle
Projection

Dimensions are shown: mm
Specifications and dimensions subject to change



K12 High Performance Key Switches

SERIES

K12GO

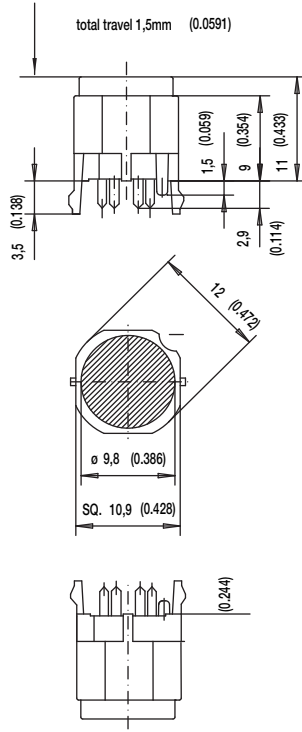

PCB LAYOUT, MOUNTING SIDE

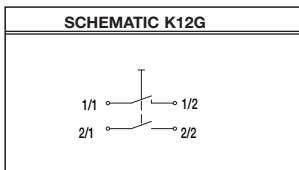
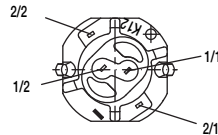
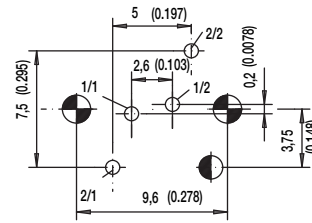

| Hole | Ø | Without LED | Description | Terminal Section | Surface |
|------|---------------|-------------|-------------|-------------------------|---------|
| | 1,7 (.069) | 2x | snap-in | | |
| | 1,6 (.062) | 1x | code | | |
| | 0,9 (.035) | | LED | m0.5 (.020) | Sn |
| | | 2x | switch 2 | 0.7 x 0.3 (.028 x .012) | Sn |
| | | 2x | switch 1 | 0.7 x 0.2 (.028 x .081) | Sn |



Key Switches



Dimensions are shown: mm
Specifications and dimensions subject to change

K12

High Performance Key Switches

CAP COLOR

| OPTION CODE | COLOR |
|-------------|------------------|
| NONE | Version with LED |
| BK | Black - no LED |
| YE | Yellow - no LED |
| RD | Red - no LED |
| GY | Gray - no LED |

LED COLOR

| OPTION CODE | COLOR |
|-------------|--------------------|
| NONE | Models without LED |
| GN | Green |
| YE | Yellow |
| OG | Orange |
| RD | Red |
| WH | White |
| BU | Blue |

| STANDARD LED CODE | COLOR |
|-------------------|--------------------|
| NONE | Models without LED |
| LV306 | Green |
| LV327 | Yellow |
| LV315 | Orange |
| LV352 | Red |
| LV302 | White |
| LV328 | Blue |

TRAVEL

- 1** 1 mm
- 1.5** 1.5 mm
- 2** 2 mm

OPERATING FORCE

| OPTION CODE | OPERATING FORCE |
|----------------|--------------------------------|
| 1.5N OD | 1.5 N, 150g without snap-point |
| 2.5N | 2.5 N, 250g |
| 3.5N | 3.5 N, 350g |
| 5N | 5 N, 500g |
| 3.5/7N | 3.5/7 N, 350/700g |
| 6/12N | 6/12 N, 600-1200g |

CONTACT ARRANGEMENT OPTION

1R SPST NC (SPECIAL REQUEST FOR NORMALLY CLOSED OPTION)



D

Key Switches



Dimensions are shown: mm
Specifications and dimensions subject to change

PVA Short Stroke Key Switches

Features/Benefits

- **Compact design**
- **Short stroke to latch**
- **Wide variety of actuator heights**
- **Adapted for medium power applications**
- **RoHS compliant and compatible**

Typical Applications

- **Automotive (air conditioning, lighting)**
- **Industrial**
- **Control panel**

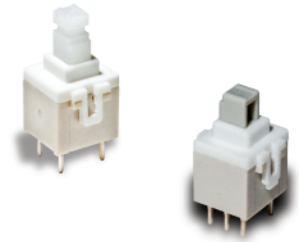

Construction

FUNCTION: Momentary, Push-Push
 CONTACT ARRANGEMENT:
 PVA1: 2 make contacts (DPST)
 PVA2: 2 change over contacts (DPDT)
 SWITCHING MODE: Non-shorting
 TERMINALS: PC pins¹

Mechanical

TOTAL TRAVEL / LATCHING TRAVEL:
 OA: 2,4 mm
 EE: 2,4 / 1,5 mm
 ELECTRICAL TRAVEL: 0.8 mm (1.1 for PVA2 OA H5)
 OPERATING FORCE: 1,2N; 1,7N; 3,5N

Process

SOLDERABILITY:
 Wave soldering, compatible with lead free soldering profile
 Hand soldering, 350°C for 3 seconds

Note: Specifications listed above are for switches with standard options.
 For information on specific and custom switches, please contact technical support using the "Ask a Specialist" option on the PVA product web page.√

Electrical

SWITCHING POWER MAX.: 3 W DC
 SWITCHING VOLTAGE MAX.: 32 V DC
 SWITCHING CURRENT MAX.: 100 mA DC*
 DIELECTRIC STRENGTH (50 Hz / 1 min):
 1000 V between open contacts, PVA2: 750 V
 OPERATING LIFE:
 OA (momentary): ≥ 1 x 10⁶ operations
 EE (push-push): ≥ 1 x 10⁵ operations
 CONTACT RESISTANCE: Initial ≤ 100 mΩΩ
 INSULATION RESISTANCE: ≥ 10¹⁰ Ω
 BOUNCE TIME: ≤ 3 ms

Environmental

OPERATING TEMPERATURE: -40°C to 85°C.²

- 1) "Snap-in" contacts on request, Version SNA with pins bent inside (standard)
 2) With button +70°C

How To Order

Our easy build-a-switch concept allows you to mix and match options to create the switch you need. To order, select desired option from each category and place it in the appropriate box. **Some of the configurations may not be available or could require some development.**

Switch

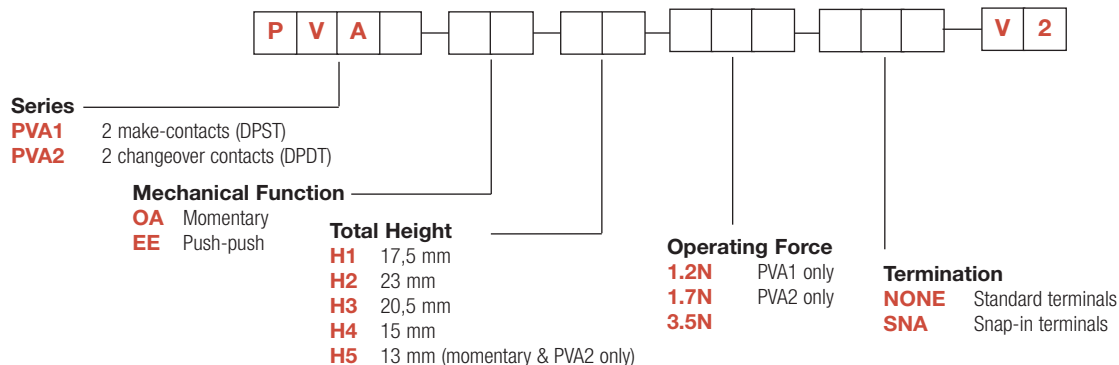

Button

Buttons must be ordered separately.
 Shipped in bulk.

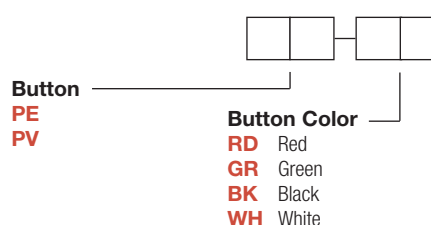

PVA Short Stroke Key Switches

SERIES

PVA1 (DPST)

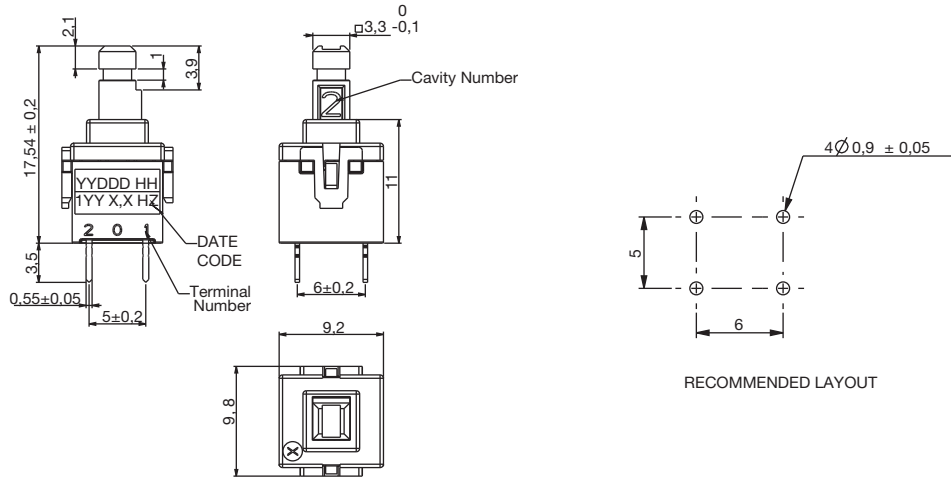

PVA2 (DPDT)

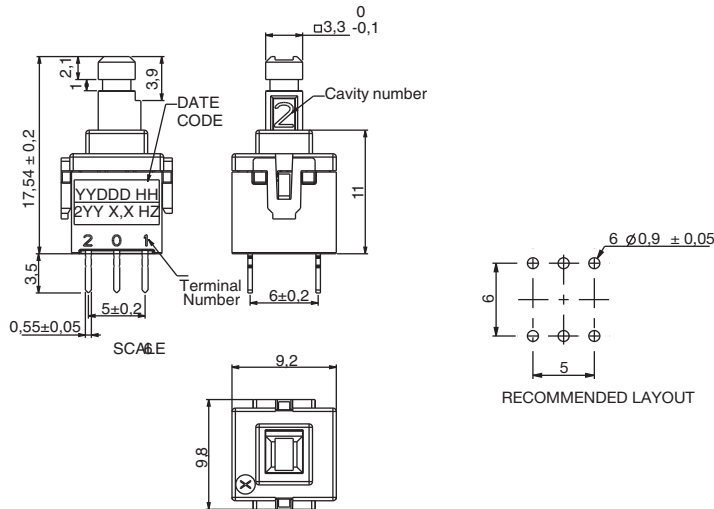

D

Key Switches

MECHANICAL FUNCTION

| OPTION CODE | FUNCTION |
|-------------|-----------|
| OA | Momentary |
| EE | Push-Push |

OA

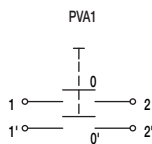

PVA2

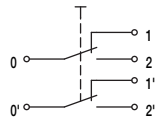

EE

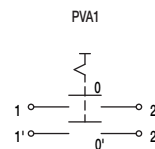

PVA2

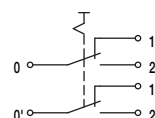

First Angle Projection

Dimensions are shown: mm
Specifications and dimensions subject to change



PVA Short Stroke Key Switches

TOTAL HEIGHT

H1 17,5 MM

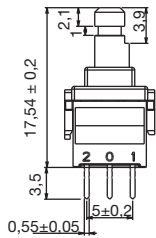

H2 23 MM

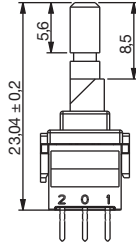

H3 20,5 MM

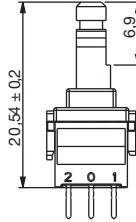

H4 15 MM

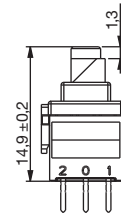

H5 13 MM
(MOMENTARY ONLY)

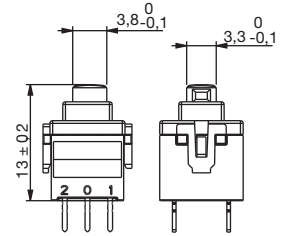

OPERATING FORCE

1.2N PVA1 ONLY
1.7N PVA2 ONLY
3.5N

TERMINATION

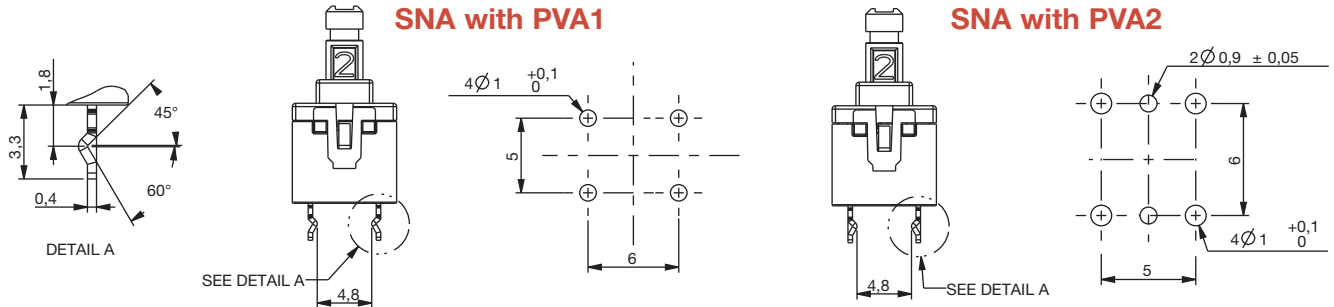

BUTTONS

BUTTONS MUST BE ORDERED SEPARATELY. SHIPPED IN BULK.

PE

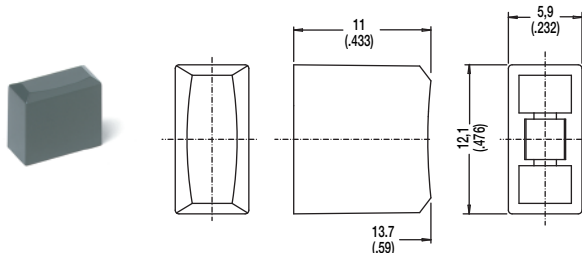

| OPTION CODE | COLOR |
|-------------|-------|
| RD | Red |
| GY | Gray |
| BK | Black |
| WH | White |

PV

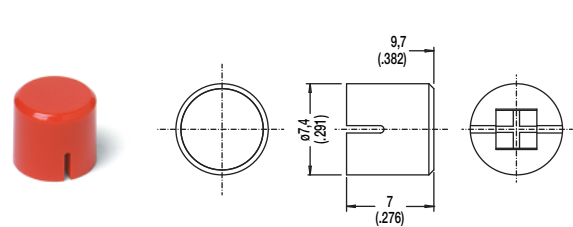

First Angle Projection

Dimensions are shown: mm
Specifications and dimensions subject to change

D6 SPST Momentary Key Switches

Features/Benefits

- Easy X, Y coding on single side PCB
- Positive tactile feedback
- High temperature
- Wide variety of colors & styles
- RoHS compliant and compatible

Typical Applications

- Video
- Electronic games
- Appliances



Construction

FUNCTION: momentary
CONTACT ARRANGEMENT: 1 make contact (SPST), NO
DISTANCE BETWEEN BUTTON CENTERS, MIN.: 12,7 (0.500)
TERMINALS: PC pins

Electrical

SWITCHING POWER MAX.: 3 VA
SWITCHING VOLTAGE MAX.: 32 V DC
SWITCHING CURRENT MAX.: 100 mA DC
DIELECTRIC STRENGTH (50 Hz / 1 min): 250 V
OPERATING LIFE with max. switching power: (2,5x10⁵ operations)
CONTACT RESISTANCE: ≤100 mΩ
INSULATION RESISTANCE: ≥10⁸ Ω
BOUNCE TIME: ≤10 ms

Packaging

The D6 switches are delivered in boxes containing 10 trays with 250 pieces each: Total 2,500 pieces per box.
The D6 buttons are delivered in bulk with 2500 pieces per box.

Mechanical

SWITCHING TRAVEL:
Version F1: 0.2mm ≤ Te ≤ 1.0 mm
Version F2: 0.3mm ≤ Te ≤ 1.1 mm
OPERATING FORCE:
Version F1: 0.8N ≤ Fa ≤ 1.8N
Version F2: 2.0N ≤ Fa ≤ 3.5N

Environmental

OPERATING TEMPERATURE: -20°C to 85°C.

Process

SOLDERABILITY:

Wave soldering, compatible with lead free soldering profile
Hand soldering, 350°C for 3 seconds

How To Order

Our easy build-a-switch concept allows you to mix and match options to create the switch you need. To order, select desired option from each category and place it in the appropriate box.

Switch

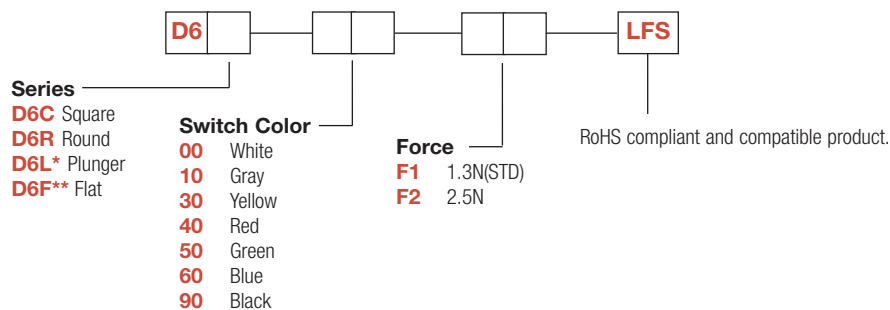

*Available only in color 90 (black).

** Available only in color 90 (black) and 00 (white).

Button

Buttons can be ordered separately.
Shipped in bulk.

D6 button for use with D6C only.

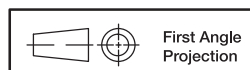
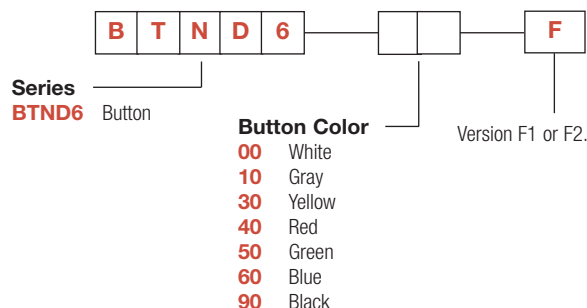

Dimensions are shown: mm
Specifications and dimensions subject to change

D6 SPST Momentary Key Switches

SERIES

D6C

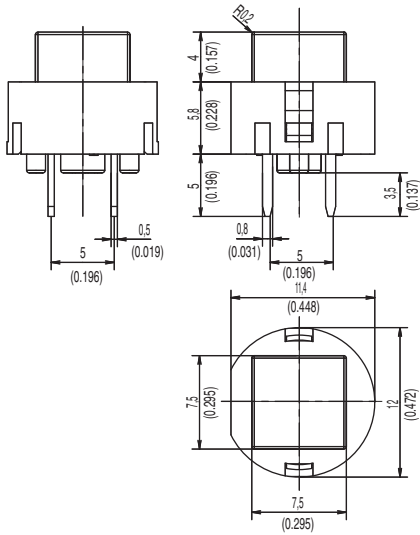
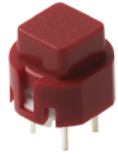

D6R

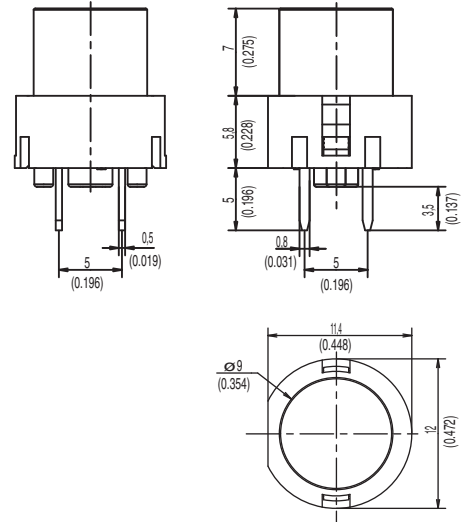

D6L ONLY AVAILABLE IN BLACK

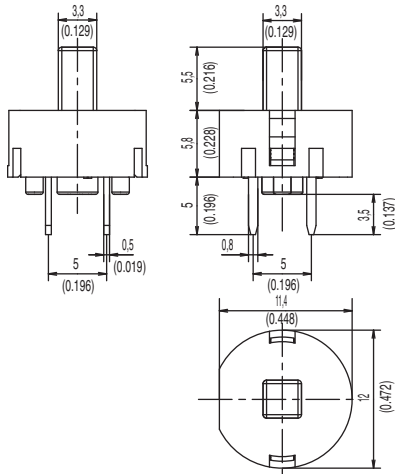

D6F

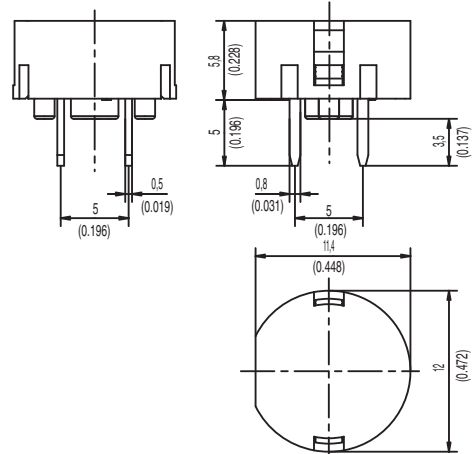

D

Key Switches



First Angle
Projection

Dimensions are shown: mm
Specifications and dimensions subject to change

D6 SPST Momentary Key Switches

SWITCH COLORS

| OPTION CODE | SWITCH COLOR |
|-------------|--------------|
| 00 | WHITE |
| 10 | GRAY |
| 30 | YELLOW |
| 40 | RED |
| 50 | GREEN |
| 60 | BLUE |
| 90 | BLACK |

PCB LAYOUT

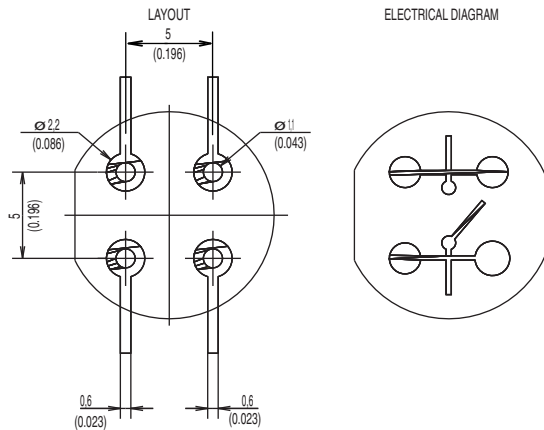

BUTTON AVAILABLE

BTND6 Buttons must be ordered separately. Shipped in bulk.

NOTE: Only compatible with D6C.

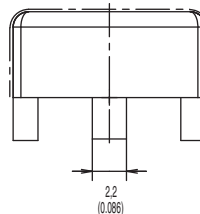
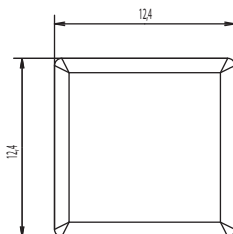
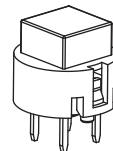
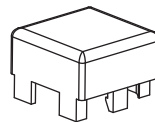
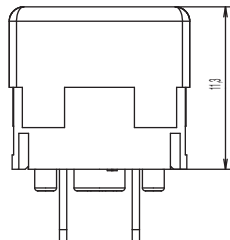

| OPTION CODE | BUTTON COLOR |
|-------------|--------------|
| 00 | WHITE |
| 10 | GRAY |
| 30 | YELLOW |
| 40 | RED |
| 50 | GREEN |
| 60 | BLUE |
| 90 | BLACK |



Dimensions are shown: mm
Specifications and dimensions subject to change



D

Key Switches

KS Single Pole Key Switches

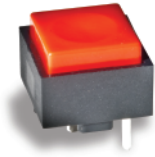

Features/Benefits

- Positive tactile feel
- Variety of cap colors
- SPST and SPDT configurations
- RoHS compliant

Typical Applications

- Telecommunications
- Industrial
- Instrumentation

Specifications

CONTACT RATING: Q contact material: 25mA @ 50V AC .or DC max.
 ELECTRICAL LIFE: 100,000 actuations.
 CONTACT RESISTANCE: Below 100 mΩ initial @ 2-4 V DC, 100 mA
 INSULATION RESISTANCE: 10⁹Ω min.
 DIELECTRIC STRENGTH: 1,000 Vrms min. @ sea level.
 OPERATING TEMPERATURE: -30°C to 65°C.
 SOLDERABILITY: Per MIL-STD-202F method 208D, or EIA RS-186E method 9 (1 hour steam aging).

Note: Specifications and materials listed above are for switches with standard options.
 For information on specific and custom switches, consult Customer Service Center.

Materials

CASE: Glass filled nylon (UL 94V-0).
 ACTUATOR: ABS, matte finish, black standard.
 MOVABLE CONTACT: Q contact material: Stainless steel, silver plated.
 STATIONARY CONTACTS AND TERMINALS: Q contact material: copper alloy, silver plated.
 TERMINAL SEAL: Epoxy

How To Order

Our easy build-a-switch concept allows you to mix and match options to create the switch you need. To order, select desired option from each category and place it in the appropriate box.

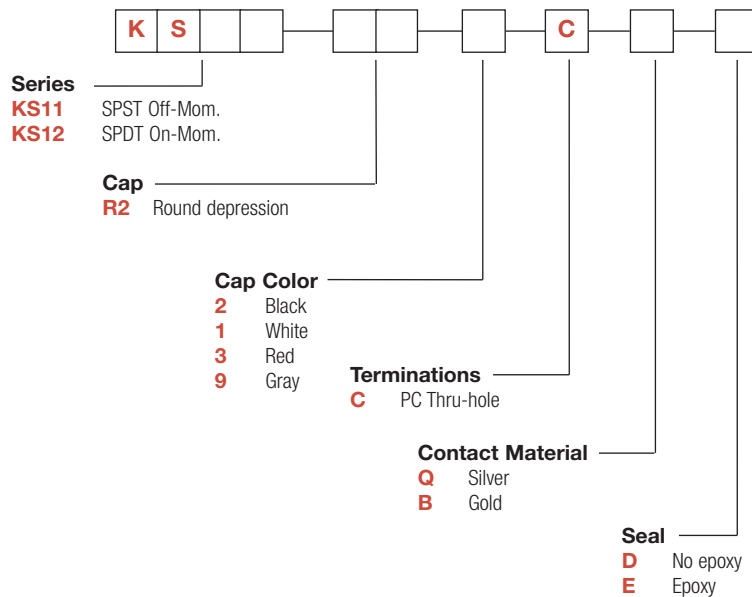

D



Key Switches

KS Single Pole Key Switches

SERIES 

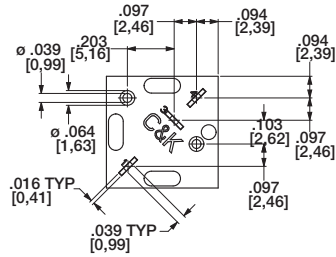
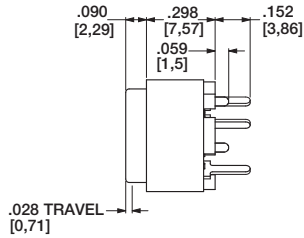
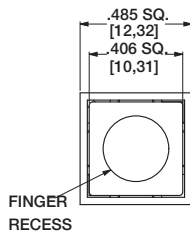
KS11 / KS12

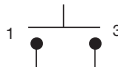

| NO. POLES | MODEL NO. | SWITCH FUNCTION | | CONNECTED TERMINALS | | SCHEMATIC |
|-----------|-----------|-----------------|--------|---------------------|--------|--|
| | | POS. 1 | POS. 2 | POS. 1 | POS. 2 | |
| SP | KS11 | OFF | MOM. | OPEN | 1-3 | SPST  |
| | KS12 | ON | MOM. | 1-4 | 1-3 | SPDT  |

CAP 

R2 CAP WITH ROUND DEPRESSION

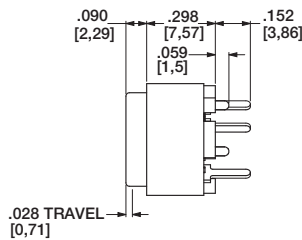
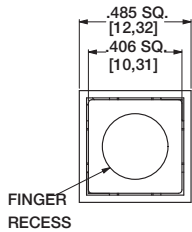

| OPTION CODE | CAP COLOR |
|-------------|-----------|
| 2 | BLACK |
| 1 | WHITE |
| 3 | RED |
| 9 | GRAY |



Key Switches



Third Angle Projection
Dimensions are shown: mm
Specifications and dimensions subject to change



KS Single Pole Key Switches

TERMINATION

C PC THRU-HOLE

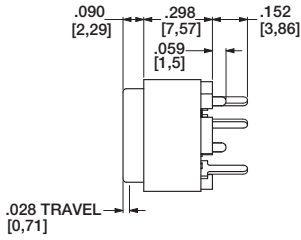

PC MOUNTING

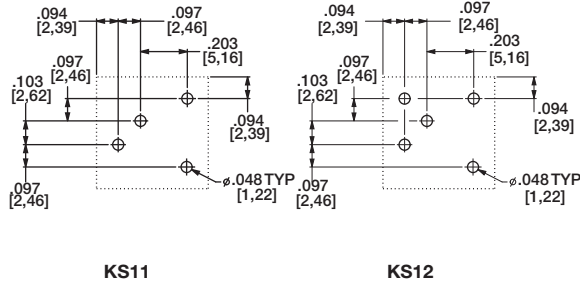

MULTIPLE SWITCH SPACING

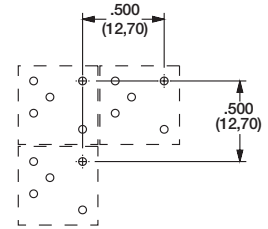

CONTACT MATERIAL

| OPTION CODE | CONTACT MATERIAL | TERMINAL PLATING | RATINGS | |
|-------------|---------------------|---------------------|---------------------------------|----------------------------------|
| | | | POWER | |
| Q | SILVER ² | SILVER ² | 25 mA MAX. @ 50 V AC OR DC MAX. | |
| B | GOLD ¹ | GOLD ¹ | LOW LEVEL/DRY CIRCUIT | 0.4 VA MAX. @ 20 V AC OR DC MAX. |

- MOVABLE CONTACT: Stainless steel, with gold plate over nickel plate.
STATIONARY CONTACTS & ALL TERMINALS: Copper alloy, with gold plate over nickel plate.
- MOVABLE CONTACT: Stainless steel, silver plated.
STATIONARY CONTACTS & ALL TERMINALS: Copper alloy, silver plated.

NOTE: Any models supplied with Q or B contact material are RoHS compliant.



D

D NO EPOXY SEAL

Key Switches

SEAL

E EPOXY SEAL

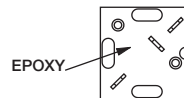

Third Angle Projection

Dimensions are shown: mm
Specifications and dimensions subject to change



DIGITAST Microminiature SPDT, Key Switches

Features/Benefits

- High reliability/long life
- Designed for low level switching
- Ready to implement on PCB
- Latching function available
- Several button options
- RoHS compliant and compatible

Typical Applications

- Medical
- Instrumentation
- Industrial electronics
- Audio electronics

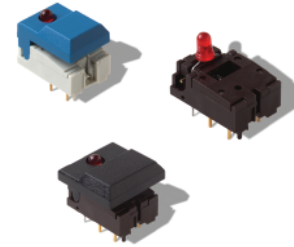

Construction

FUNCTION: momentary or push-push
 CONTACT ARRANGEMENT: 1 change over contact SPDT, NO
 MODE OF SWITCHING: Non-shorting
 DISTANCE BETWEEN BUTTON CENTERS:
 HORIZONTAL MINIMUM: 12,7 (0.500) or 17,78 (0.700)
 VERTICAL MINIMUM: 17,78 (0.700)
 TERMINALS: PC pins
 MOUNTING: Soldering, centering pins

Mechanical

TOTAL TRAVEL: ≤ 3 (.0018)
 SWITCHING TRAVEL: 1,5 (0.0591)
 LATCHING TRAVEL: 1,8 (0.0709)
 OPERATING FORCE: 1.5 +/- 0.5 N (150 +/- 50 grams)

Process

SOLDERABILITY:
 Wave soldering, compatible with lead free soldering profile
 Hand soldering, 350°C for 3 seconds

Electrical

SWITCHING POWER MAX.: 240 mW DC
 SWITCHING VOLTAGE MAX.: 24 V DC
 SWITCHING CURRENT MAX.: 10 mA DC
 CARRYING CURRENT AT 20°C (push-push version): 100 mA
 DIELECTRIC STRENGTH (50 Hz, 1 min): 500 V
 OPERATING LIFE with or without max. switching power
 Momentary: ≥ 5 x 10⁶ operations
 Push-push: ≥ 5 x 10⁵ operations
 CONTACT RESISTANCE: Initial ≤ 50 mΩ
 After 5 x 10⁶ operations: ≤ 100 mΩ
 INSULATION RESISTANCE: ≥ 10¹⁰ Ω
 CAPACITANCE at f= 10 kHz: ≤ 0.8pF
 BOUNCE TIME: ≤ 2.5 ms
 Operating speed 400 mm/s (15.75/s)

Environmental

OPERATING TEMPERATURE: -25°C to 85°C.

How To Order

Our easy build-a-switch concept allows you to mix and match options to create the switch you need. To order, select desired option from each category and place it in the appropriate box. **Some of the configurations may not be available or could require some development.**

Switch

Reference
SER BK AU OA

Series
SER Narrow button
SET Wide button
SERU Switch body only (no button)

LED
NONE No LED
L 1 LED
2L 2 LED's

Button Color**
None (SERU)
BK Black
GY Gray
WH White
RD Red
BU Blue

LED Spacing*
NONE Narrow LED Spacing (TYP Europe)
7.62 Wide LED Spacing (TYP No. America)

1st LED Color***
NONE No LED
RD Red
YE Yellow
GN Green

2nd LED Color***
NONE No LED
RD Red
YE Yellow
GN Green

Contact Material
AU Gold

Function
EE Latching
OA Non-latching

Body Color
NONE White (STD)
BRN Brown

Button

Reference
SRK BK

Button Style
SR Narrow
ST Wide

LED Holes
NONE No LED holes
L 1 LED hole
2L 2 LED holes

Button Color**
BK Black
GY Gray
WH White
RD Red
BU Blue

Latching
None For use with momentary switch
EE With "EE" staple for latching

* LED spacing only applies when 1 LED requested
 ** Additional button colors available by request
 *** Additional LED colors available by request including Bi color configurations



Dimensions are shown: mm
 Specifications and dimensions subject to change



DIGITAST Microminiature SPDT, Key Switches

DESIGNATION

SER NARROW BUTTON

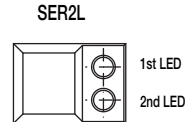
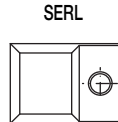
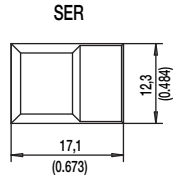
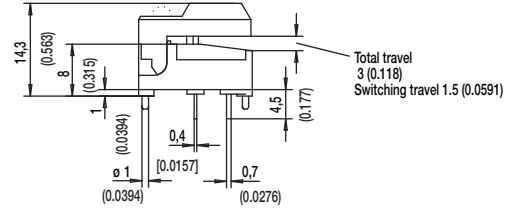
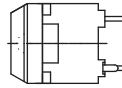
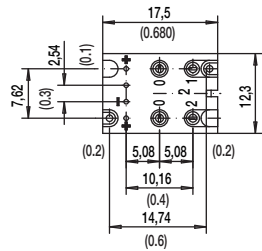
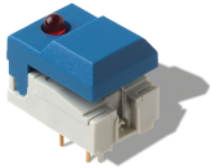

SET WIDE BUTTON

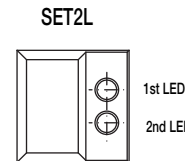
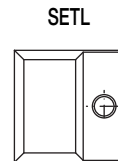
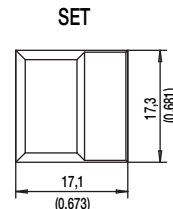
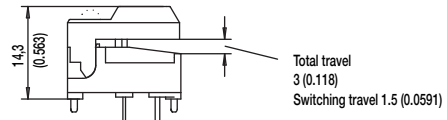
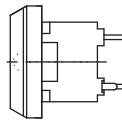
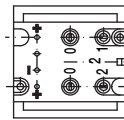
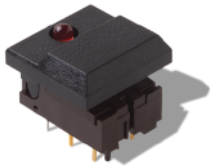

SERU NO BUTTON

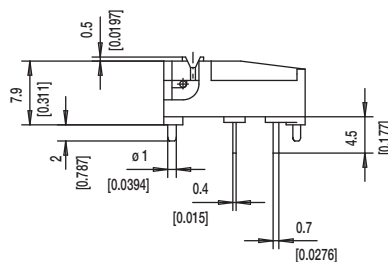
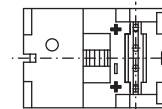
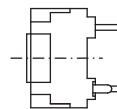
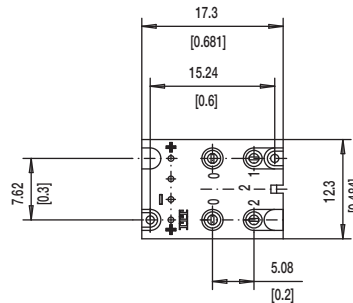

Key Switches



Dimensions are shown: mm
Specifications and dimensions subject to change



DIGITAST Microminiature SPDT, Key Switches

LED

NONE NO LED

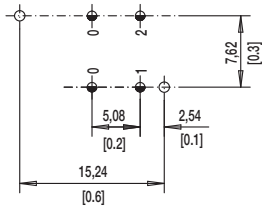

L 1 LEDs

7.62 mm Spacing (TYP No. America)

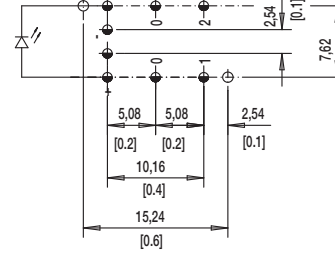

NARROW SPACING (TYP EUROPE)

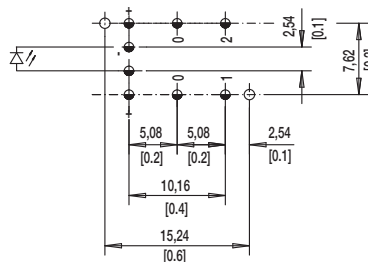

TOP VIEW OF PCB

2L 2 LEDs

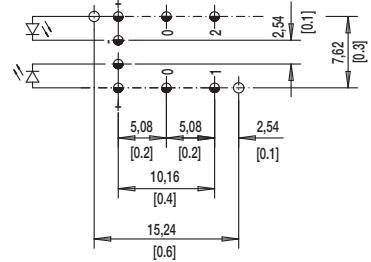

⌀ 1.0±0.1 (0.0394±0.00349)

⌀ 1.1±0.05 (0.0433±0.00197)

BUTTON COLOR

BK BLACK

GY GRAY

Other button colors available by request [red (RD), green (GN), white (WH), yellow (YE), blue (BU), orange (OG)].

LED COLOR

| OPTION CODE | COLOR |
|-------------|--------------------|
| NONE | Models without LED |
| RD | Red |
| GN | Green |
| YE | Yellow |

CONTACT MATERIAL

| OPTION CODE | MATERIAL |
|-------------|----------|
| AU | Gold |

FUNCTION

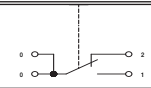
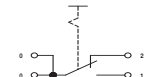
| OPTION CODE | COLOR | SCHEMATIC |
|-------------|-----------|--|
| OA | Momentary |  |
| EE | Push-Push |  |

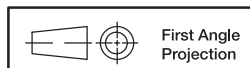

Dimensions are shown: mm
Specifications and dimensions subject to change

ED & EDM Domes



Features

- Short travel
- Good tactile feedback
- Self cleaning
- 3 actuation forces
- RoHS

Typical Applications

- Aircraft
- Instrument
- Panels
- Radio equipment

Specification

ED: Disc element
 EDM: Disc element and double dome
 FUNCTION: Momentary action
 CONTACT TYPE: Normally open - SPST
 TERMINALS: Through hole PCB terminations or Tabs
 OPERATING LIFE: 1,000,000

Electrical

| | Silver | Gold |
|------------------------|-----------------------------|--------------|
| MAXIMUM POWER: | 1.0 VA | 0.2 VA |
| MAXIMUM VOLTAGE: | 100 VDC | 100 VDC |
| MINIMUM VOLTAGE: | 20m VDC | 20m VDC |
| MIN/MAX CURRENT: | 1.0 mA - 100 mA | 50µA - 50 mA |
| DIELECTRIC STRENGTH: | ≥ 250 Vrms | |
| CONTACT RESISTANCE: | ≤ 100 mΩ | |
| INSULATION RESISTANCE: | Initial measurement: ≥ 1 GΩ | |
| (between terminals) | After damp heat: ≥ 10 MΩ | |
| BOUNCE TIME: | ≤ 3 ms | |

Packaging

Trays 50 pieces.

Mechanical

Environmental

| | Silver | Gold |
|------------------------|---------------|---------------|
| OPERATING TEMPERATURE: | -25°C to 70°C | -55°C to 85°C |

| Type | Operating force Newtons (grams) | Tactile Feeling (Δ%) | Return Force N | Travel (mm) |
|---------------|---------------------------------|----------------------|----------------|--------------|
| EDSAC LFS | 2.4 (240) ± 25% | ≥ 30% | ≥ 0.4 N | 0.3mm ± 0.15 |
| EDSSC LFS | 2.4 (240) ± 25% | ≥ 30% | ≥ 0.4 N | 0.3mm ± 0.15 |
| EDM450SAC LFS | 4.5 (450) ± 25% | ≥ 25% | ≥ 1.0 N | 0.5mm ± 0.25 |
| EDM650SSC LFS | 6.5 (650) ± 25% | ≥ 25% | ≥ 1.6 N | 0.6mm ± 0.25 |

SIMULTANEITY: ≤ 0.05 mm



D

Key Switches

How To Order

Our easy build-a-switch concept allows you to mix and match options to create the switch you need. To order, select desired option from each category and place it in the appropriate box.

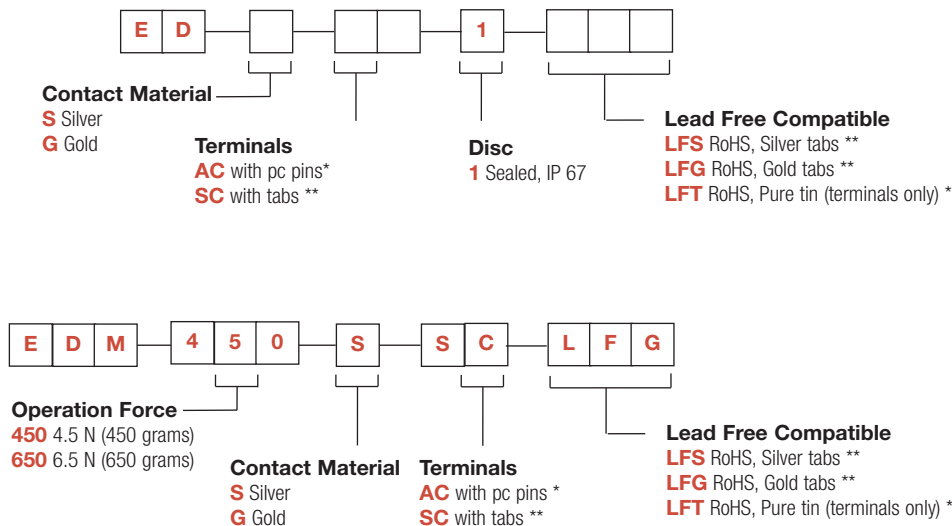

Note
 * AC terminals only available with LFT
 ** SC terminals only available with LFS or LFG



Dimensions are shown: mm
 Specifications and dimensions subject to change



ED

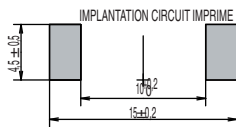
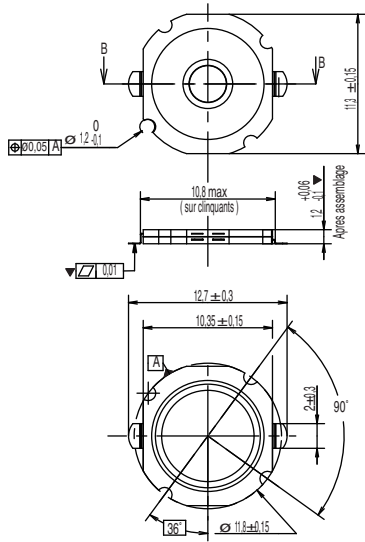

EDM

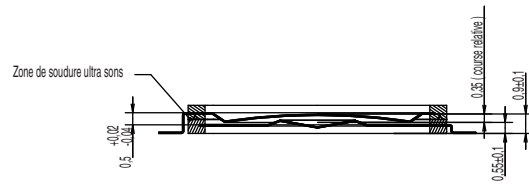
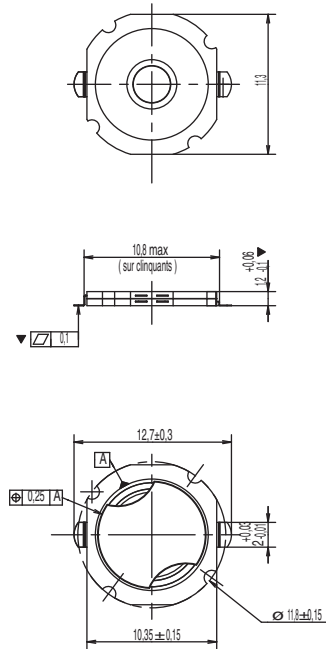

Switch Action Principal

The disc contact is essentially made of two separate conductive dome diaphragms separated by an insulated material.

The upper diaphragm is shaped so that under pressure it collapses suddenly and establishes contact with the lower diaphragm.

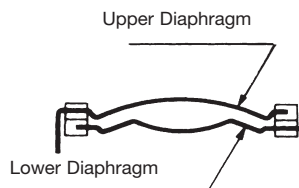

Switch in resting position

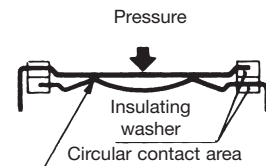

Switch in active position



First Angle Projection

Dimensions are shown: mm
Specifications and dimensions subject to change

KBD Keyboard Switches

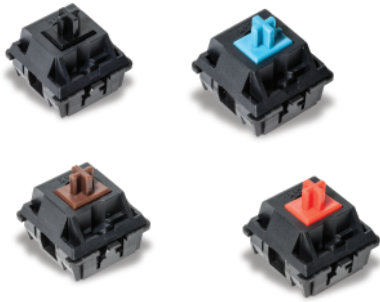

Features

- Long operating life
- High reliability
- Excellent ergonomics
- RoHS compliant

Typical Applications

- Gaming keyboard
- Professional keyboard
- Industrial keyboard
- Workstation keyboard

Specifications

CONTACT ARRANGEMENT: SPST
 CONTACT RATING: 10mA @ 12 VDC
 INITIAL CONTACT RESISTANCE: 200 m Ω max. (25m Ω typically)
 INSULATION RESISTANCE: 100M Ω min. @ 100 VDC
 DIELECTRIC STRENGTH: 250 VAC (50-60 Hz) 60 sec.
 ELECTRICAL LIFE: 50,000,000 cycles
 PRE-TRAVEL: 1.5 ~ 2 mm
 OVERTRAVEL: 4 mm
 OPERATING TEMPERATURE: -10°C to +70°C

Materials

COVER: Nylon (UL94V-0)
 HOUSING: Nylon (UL94V-0)
 KNOB: POM (UL94HB)
 TERMINALS: Copper alloy, gold plated in contact area,
 Tin plated in soldering area
 SPRING: Stainless steel

How To Order

Our easy build-a-switch concept allows you to mix and match options to create the switch you need. To order, select desired option from each category and place it in the appropriate box.

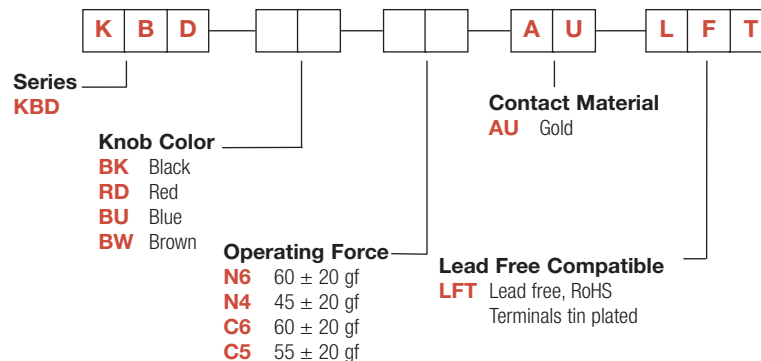

D

Key Switches

KBD Keyboard Switches

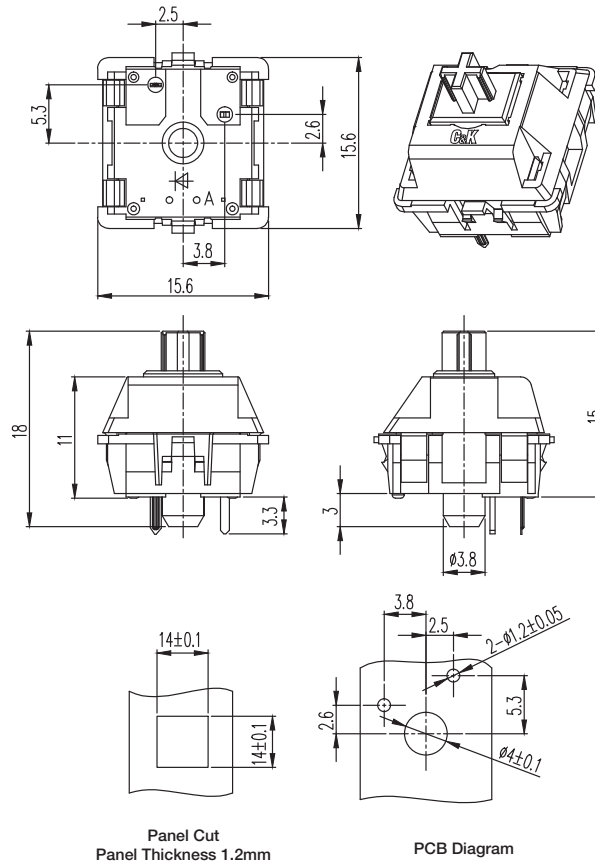

| PART NUMBER | FEELING | KNOB COLOR | OPERATING FORCE | OPERATING LIFE |
|--------------|----------------------|------------|-----------------|----------------|
| KBDBKN6AULFT | Linear actuation | BLACK | 60±20gf | 50,000,000 |
| KBDRDN4AULFT | Linear actuation | RED | 45±20gf | 50,000,000 |
| KBDBUC6AULFT | Click pressure point | BLUE | 60±20gf | 50,000,000 |
| KBDBWC5AULFT | Click pressure point | BROWN | 55±20gf | 50,000,000 |



Key Switches

Detect Switches

Product Selection Guide







| Detect |  |  |  |  |  |  |
|-----------------------------|---|---|---|---|---|---|
| Series | HDT | DS | HDS | HDP | SDP | SDS |
| Travel to Make (mm) | 0,3 | See datasheet | 0,17 | 0,24 | 29,2° | 0,35 |
| Overtravel (mm) | 0,75 | See datasheet | 0,5 | 1,66 | 39,1° | 1,65 |
| Total Travel (mm) | 1,05 | See datasheet | 1,07 | 1,9 | 68,3° | 2,0 |
| Actuator Length (mm) | 1,4 | See datasheet | 1,17 | 2,15 | 1,85 | 2,5 |
| Life Expectancy | 100,000 cycles | 20,000; 50,000; 100,000 cycles | 100,000 cycles | 100,000 cycles | 50,000 cycles | 50,000 cycles |
| Contact Type | SPST N.O. | SPST SPDT | SPST N.O. | SPST N.O. | SPDT | SPST N.O. SPST N.C. |
| Max. Voltage (V) | 5 | 5 V; 16 V 30 V | 5 | 5 | 5 | 12 |
| Max. Switching Current (mA) | 1 mA | 1 mA; 5 mA 100 mA | 1 mA | 1 mA | 1 mA | 100 mA |
| Sealing | No | No | No | No | No | No |
| Mounting | Surface mount | Thru-hole Solder lug | Surface mount | Surface mount | Surface Mount | Surface mount |
| Page number | E-4 | E-7 | E-12 | E-14 | E-16 | E-17 |

| Detect |  |  |  |  |  |  |
|-----------------------------|---|---|---|--|---|---|
| Series | DDS | MDS | KDS | KM | MPS | ZMA |
| Travel to Make (mm) | 0,45 | 2,5 max. | 1,25 max. | 4,06 | See datasheet | 1,3 max. |
| Overtravel (mm) | 1,95 | 0,15 min. | 8,9 | 1,78 | See datasheet | 0,2 min. |
| Total Travel (mm) | 2,4 | 2,9 | 10,16 | 5,84 | See datasheet | 1,5 |
| Actuator Length (mm) | 2,6 | R 8,4 | 10,16 | 10,11 | N/A | |
| Life Expectancy | 50,000 cycles | 100,000 cycles | 10,000 cycles | 10,000 cycles | 10,000,000 cycles | 300,000 cycles |
| Contact Type | SPST N.O. | SPDT | SPST N.O. SPST N.C. | SPDT | SPST N.O. | SPDT |
| Max. Voltage (V) | 30 | 30 | 20 | 125 V AC | 30 | 125 V |
| Max. Switching Current (mA) | 100 mA | 300 mA | .4 VA | 250 mA | 300 mA | 3 Amps |
| Sealing | No | No | No | Flux tight | Yes | No |
| Mounting | Thru-hole | Thru-hole & Surface Mount | Snap-in panel | Thru-hole | Wire lead | Thru-hole |
| Page Number | E-18 | E-20 | E-26 | E-27 | E-30 | E-32 |



Detect

Detect Switches Product Selection Guide

| Detect |  |  |  |  |  |  |
|------------------------------------|---|---|---|---|---|---|
| Series | KSU | KSR2D | KSM | KSC4D | KSJ | RB |
| Travel to Make (mm) | 0,5 | 0,3 | 0,3 | 0,6 | 0,3 | See datasheet |
| Overtravel (mm) | 1,0 | N/A | 1,15 | N/A | 0,75 | N/A |
| Total Travel (mm) | 1,5 | 0,3 | 1,72 | 0,6 | 1,05 | N/A |
| Actuator Length (mm) | 1,5 | 0,8 | 1,8 | 2,6 | 1,4 | N/A |
| Life Expectancy | 100,000 cycles | 100,000 cycles | 50,000 cycles | 500,000 and 2,000,000 cycles | 100,000 cycles | 20,000; 100,000 cycles |
| Contact Type | SPST N.O. | SPST N.O. | SPST N.C. | SPST N.O. | SPST N.O. | SPST SPDT |
| Max. Voltage (V) | 32 | 32 | 32 | 32 | 5 | 5 V; 24 V |
| Max. Switching Current (mA) | 50 mA | 10 mA | 50 mA | 50 mA | 1 mA | 1 mA; 25 mA |
| Sealing | Dust and water drop proof | Dust and flux tight | Flux tight | IP67 | IP60 | No |
| Mounting | Surface mount | Surface mount | Surface mount | Surface mount | Surface mount | Thru-hole |
| Page number | E-36 | E-38 | E-40 | E-42 | E-44 | E-46 |



Detect

HDT Series Micro Mini Surface Mount Detect Switches



Features/Benefits

- Low profile package
- Design allows top or side actuation
- Low actuation force, 35 grams max.
- Pick and place compatible, available in tape & reel packaging
- RoHS compliant and compatible
- Halogen free

Typical Applications

- Consumer electronics
- Computers
- Medical devices
- ATCA and MicroTCA devices

Specifications

CONTACT RATING: 1 mA 5 VDC
 MECHANICAL AND ELECTRICAL LIFE: 100,000 cycles min.
 CONTACT RESISTANCE: 500 m Ω max. initial.
 INSULATION RESISTANCE: 100 M Ω min. between adjacent contacts.
 OPERATING TEMPERATURE: -40°C to + 85°C
 STORAGE TEMPERATURE: -40°C to + 85°C
 PACKAGING: Tape & reel

Materials

BASE: PA 46 (UL94V-0)
 COVER: PA 46 (UL94V-0)
 ACTUATOR: PA 46 (UL94V-0)
 MOVABLE BLADE: Stainless Steel, Ag over Ni plating.
 TERMINALS: Phosphor Bronze, Ag over Ni plating.
 SOLDERABILITY: Lead free compatible - No clean.

NOTE: Specifications and materials listed above are for switches with standard options. For information on specific and custom switches, consult Customer Service Center.

Build-A-Switch

Complete part numbers for HDT Series are shown below.

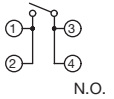
| PART NUMBER | PACKAGING | SCHEMATIC |
|----------------|-------------------------------|---|
| HDT0001 | TAPE & REEL 2,450 per reel |  |

NOTE: Available with no locating posts by adding "NP" (HDT0001NP) to Part Number.

TRAVEL:

Pre-travel: .30 mm
 Overtravel: .75 mm
 Total: 1.05 mm

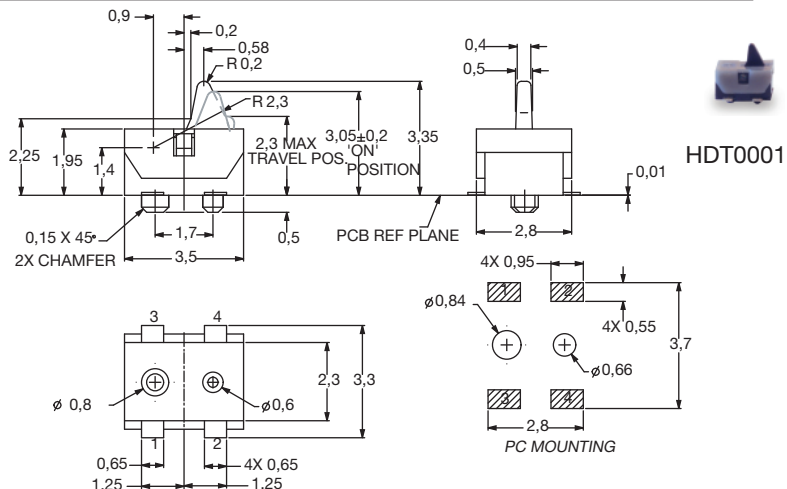

TAPE & REEL

HDT0001

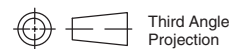
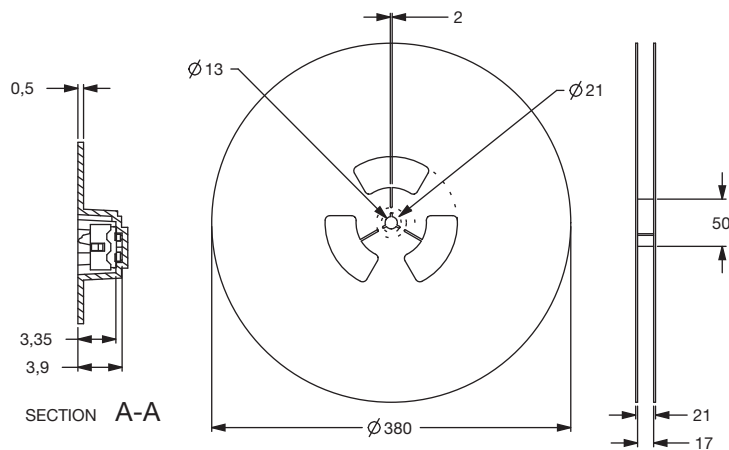
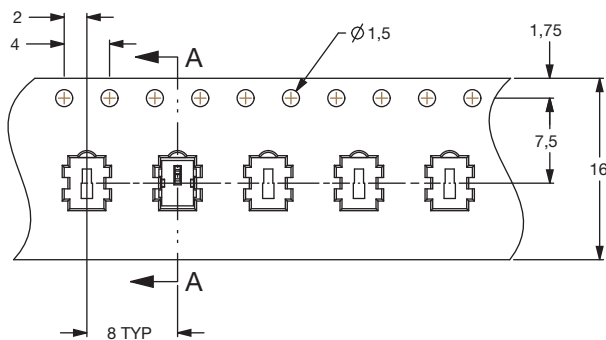

Dimensions are shown: mm
 Specifications and dimensions subject to change



Detect

HDT Series Micro Mini Surface Mount Detect Switches

HDT0004



HDT0004

| PART NUMBER | PACKAGING | SCHEMATIC |
|----------------|-------------------------------|-----------|
| HDT0004 | TAPE & REEL 2,800 per reel | |

TRAVEL:

Pre-travel: .3 mm
Overtravel: 1.0 mm
Total: 1.3 mm

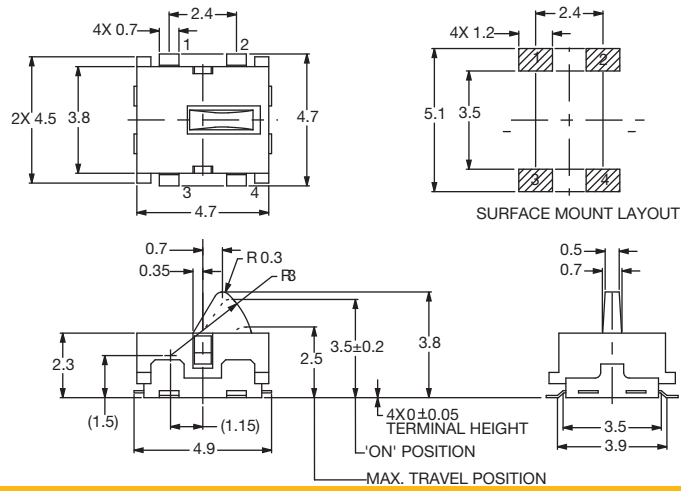

TAPE & REEL

HDT0004

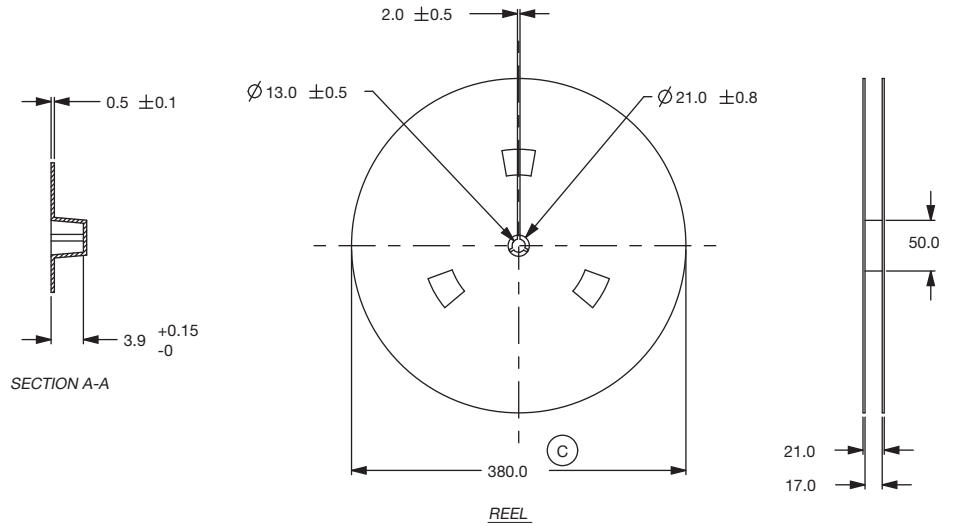
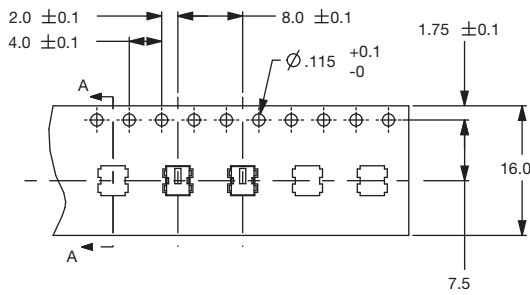

HDT0104



HDT0104

| PART NUMBER | PACKAGING | SCHEMATIC |
|----------------|-------------------------------|-----------|
| HDT0104 | TAPE & REEL 2,500 per reel | |

TRAVEL:

Pre-travel: .3 mm
Overtravel: 1.1 mm
Total: 1.4 mm

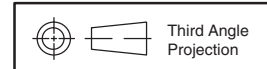
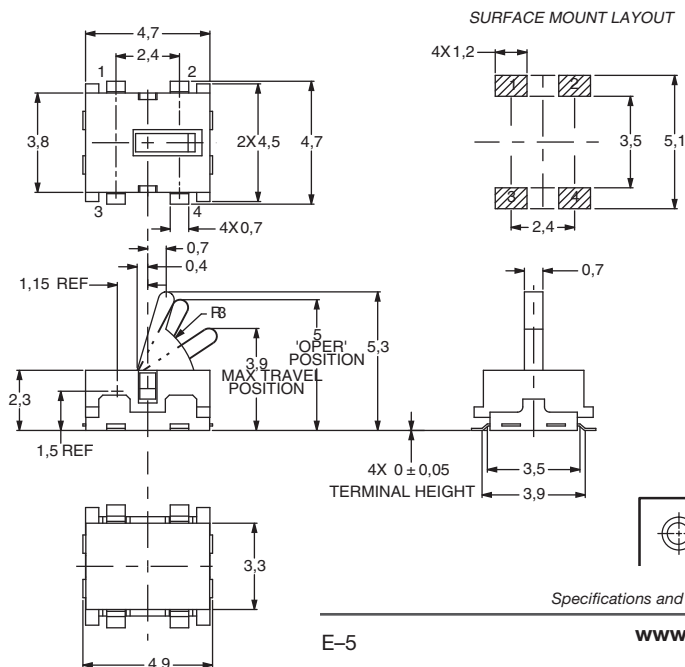

Dimensions are shown: mm
Specifications and dimensions subject to change



Detect

HDT Series Micro Mini Surface Mount Detect Switches

TAPE & REEL

HDT0104

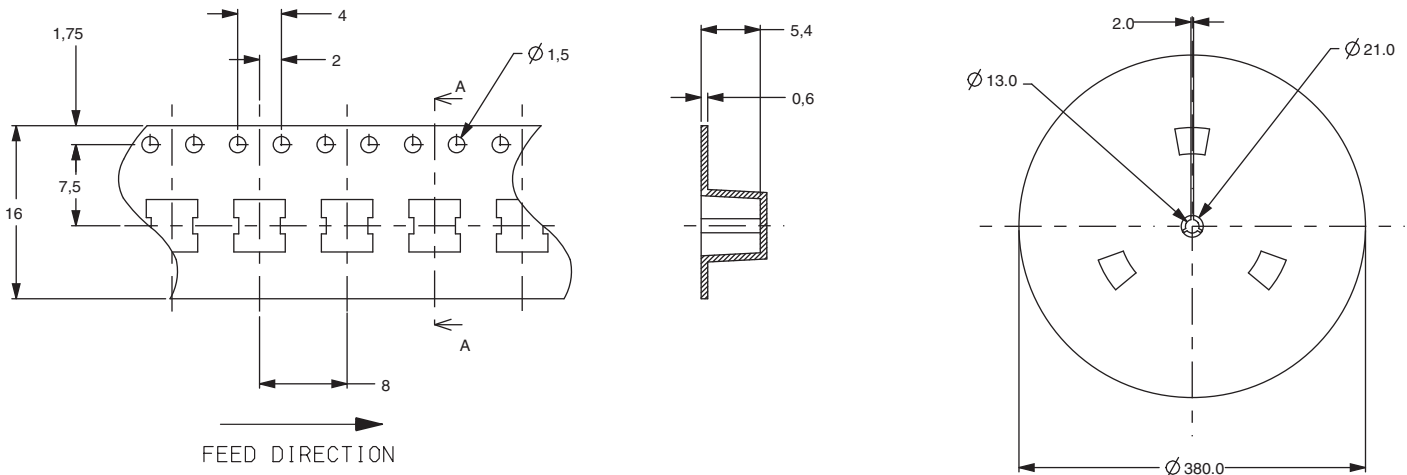

HDT0204



HDT0204

| PART NUMBER | PACKAGING | SCHEMATIC |
|----------------|-------------------------------|-----------|
| HDT0204 | TAPE & REEL 1,400 per reel | |

TRAVEL:

- Pre-travel: .3 mm
- Overtravel: 1.1 mm
- Total: 1.4 mm

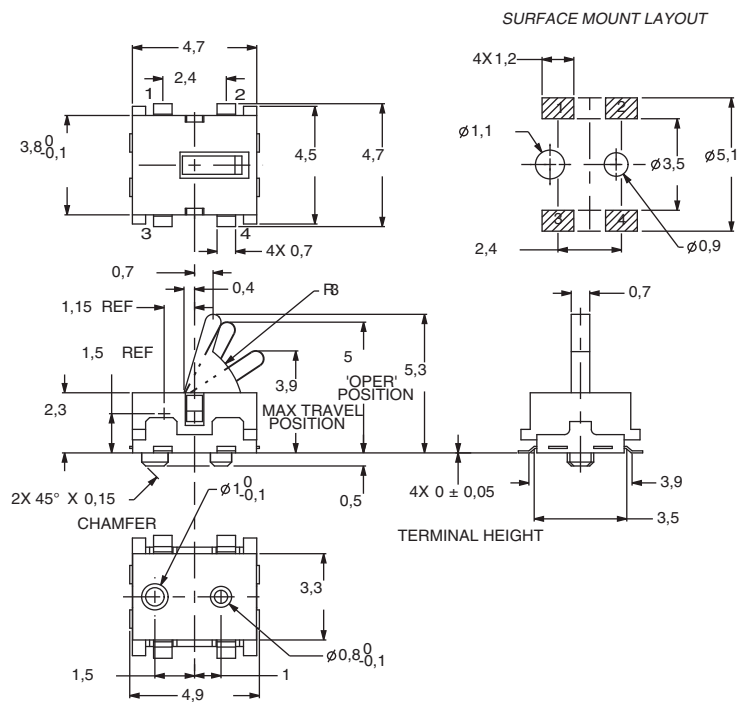

Detect

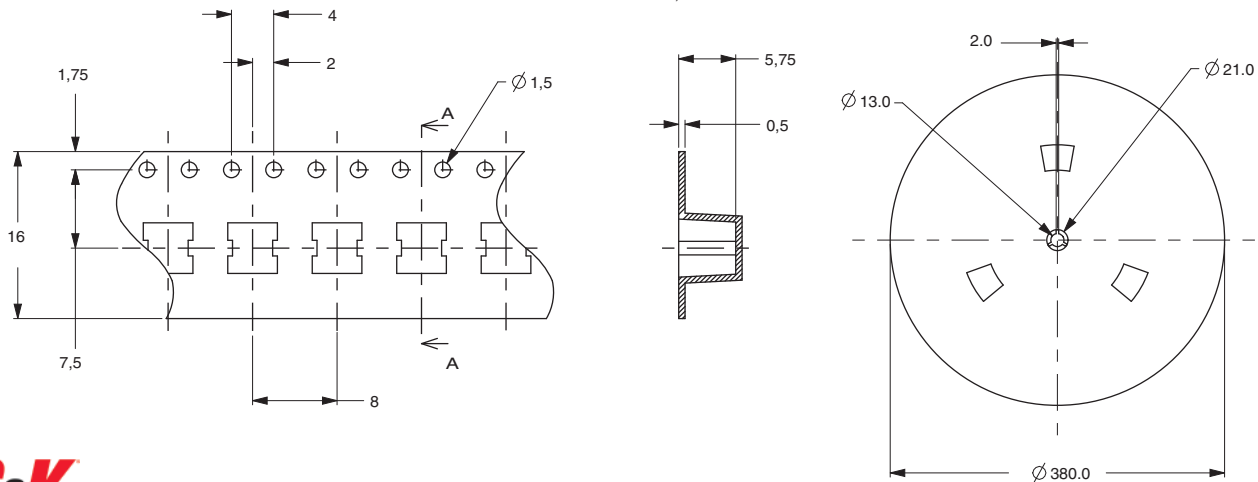

DS Series Detect Switch



Features/Benefits

- Compact design
- Low actuation force
- Detect mechanical movement
- Left and right options
- Right angle options

Typical Applications

- Computer peripherals
- Office equipment
- Consumer electronics
- Appliances
- Audio and visual equipment

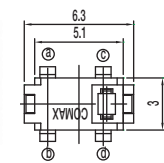

| PART NUMBER | PACKAGING | SCHEMATIC |
|-----------------|--------------|-----------|
| DS-02005 | 1,000 pieces | 1P-1T |

Specifications

CONTACT ARRANGEMENT: SPST, NO
 CONTACT RATING: 100mA @ 30 VDC
 OPERATING LIFE: 50,000 cycles
 OPERATING FORCE: 50 gf max.
 PRE-TRAVEL: 0.7 mm
 TOTAL TRAVEL: 2.6 mm
 INITIAL CONTACT RESISTANCE: 1 Ω max.
 INSULATION RESISTANCE: 100 M Ω min. @ 100 VDC 60 sec.
 DIELECTRIC STRENGTH: 100 V AC (50-60Hz) 60 sec.
 OPERATING TEMPERATURE: -20°C to +70°C.

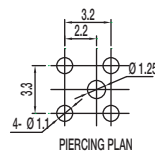
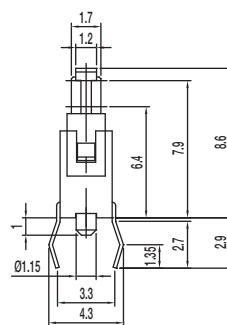
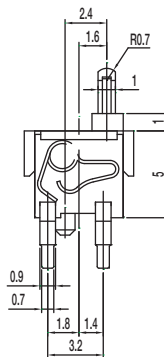

Materials

KNOB: PA
 COVER: PA
 SPRING: Gold plated, copper alloy
 HOUSING: PA
 TERMINAL: Silver plated, copper alloy

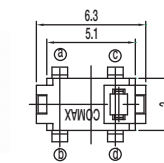

| PART NUMBER | PACKAGING | SCHEMATIC |
|----------------------|--------------|-----------|
| DS-02005 (30) | 1,000 pieces | 1P-1T |

Specifications

CONTACT ARRANGEMENT: SPST, NO
 CONTACT RATING: 100mA @ 30 VDC
 OPERATING LIFE: 50,000 cycles
 OPERATING FORCE: 30 gf max.
 PRE-TRAVEL: 0.7 mm
 TOTAL TRAVEL: 2.2 mm
 INITIAL CONTACT RESISTANCE: 1 Ω max.
 INSULATION RESISTANCE: 100 M Ω min. @ 100 VDC 60 sec.
 DIELECTRIC STRENGTH: 100 V AC (50-60Hz) 60 sec.
 OPERATING TEMPERATURE: -20°C to +70°C.

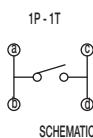
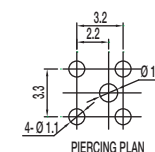
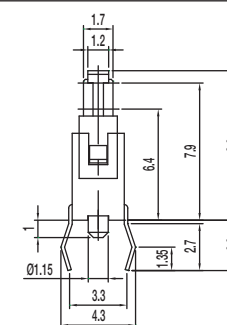
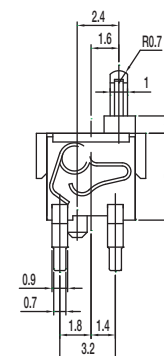

Materials

KNOB: PA
 COVER: PA
 SPRING: Gold plated, copper alloy
 HOUSING: PA
 TERMINAL: Silver plated, copper alloy



Detect

DS Series Detect Switch

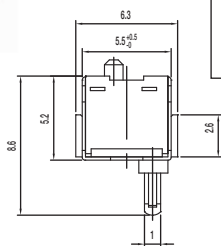

| PART NUMBER | PACKAGING | SCHEMATIC |
|-------------------|--------------|-------------------|
| DS-02005-A | 1,000 pieces | 1P-1T N.O. |

Specifications

CONTACT ARRANGEMENT: SPST, NO
 CONTACT RATING: 100mA @ 30 VDC
 OPERATING LIFE: 50,000 cycles
 OPERATING FORCE: 50 gf max.
 PRE-TRAVEL: 0.7 mm
 TOTAL TRAVEL: 2.6 mm
 INITIAL CONTACT RESISTANCE: 1 Ω max.
 INSULATION RESISTANCE: 100 M Ω min. @ 100 VDC 60 sec.
 DIELECTRIC STRENGTH: 100 V AC (50-60Hz) 60 sec.
 OPERATING TEMPERATURE: -20°C to +70°C.

Materials

KNOB: PA
 COVER: PA
 SPRING: Gold plated, copper alloy
 HOUSING: PA
 TERMINAL: Silver plated, copper alloy

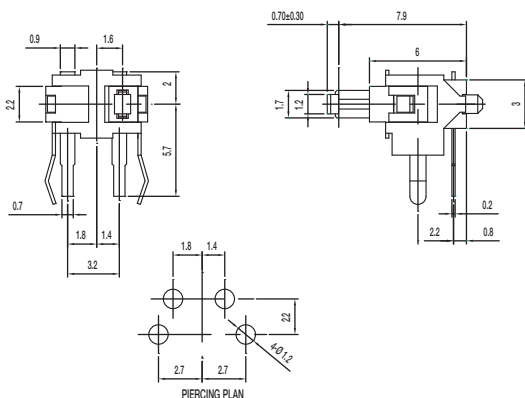

| PART NUMBER | PACKAGING | SCHEMATIC |
|-----------------|--------------|------------------------|
| DS-21805 | 2,500 pieces | C D A B N.O. |

Specifications

CONTACT ARRANGEMENT: SPDT
 CONTACT RATING: 5mA @ 5 VDC
 OPERATING LIFE: 100,000 cycles
 OPERATING FORCE: 36 gf
 TOTAL TRAVEL: 2.20 mm
 INITIAL CONTACT RESISTANCE: 1 Ω max.
 INSULATION RESISTANCE: 100 M Ω min. @ 100 VDC 60 sec.
 DIELECTRIC STRENGTH: 100 V AC (50-60Hz) 60 sec.
 OPERATING TEMPERATURE: -20°C to +70°C.

Materials

KNOB: POM
 COVER: PA46
 SPRING: Silver plated
 HOUSING: PPS
 TERMINAL: Silver plated

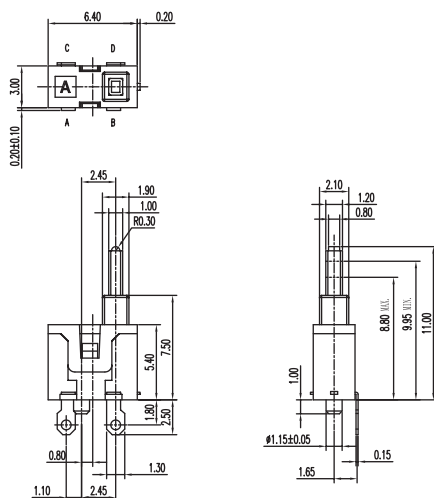

Detect



Dimensions are shown: mm
Specifications and dimensions subject to change

DS Series Detect Switch



| PART NUMBER | PACKAGING | SCHEMATIC |
|-----------------|--------------|-----------|
| DS-203-A | 2,500 pieces | N.O. |

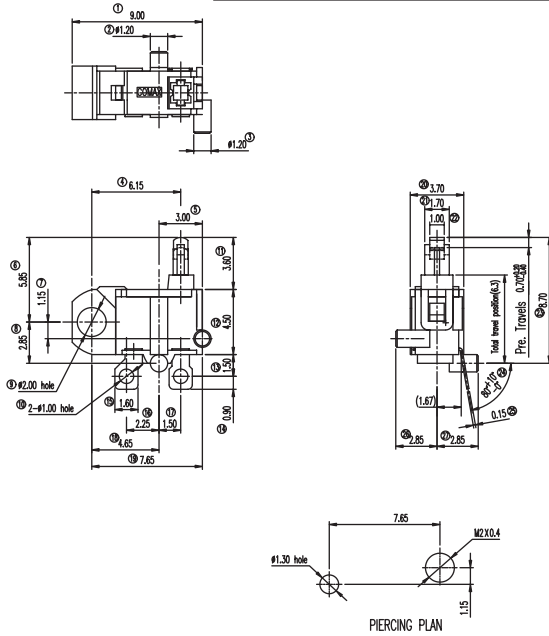

Specifications

CONTACT ARRANGEMENT: SPST
 CONTACT RATING: 100mA @ 30 VDC
 OPERATING LIFE: 50,000 cycles
 OPERATING FORCE: 36 gf
 PRE TRAVEL: 0.70 +0.20/-0.40 mm
 INITIAL CONTACT RESISTANCE: 1 Ω max.
 INSULATION RESISTANCE: 50 M Ω min. @ 250 VDC 60 sec.
 DIELECTRIC STRENGTH: 250 V AC (50-60Hz) 60 sec.
 OPERATING TEMPERATURE: -20°C to +70°C.

Materials

KNOB: POM
 COVER: PA
 SPRING: Gold plated
 HOUSING: PA
 TERMINAL: Silver plated



| PART NUMBER | PACKAGING | SCHEMATIC |
|------------------|--------------|-----------|
| DS-040-02 | 1,000 pieces | N.O. |

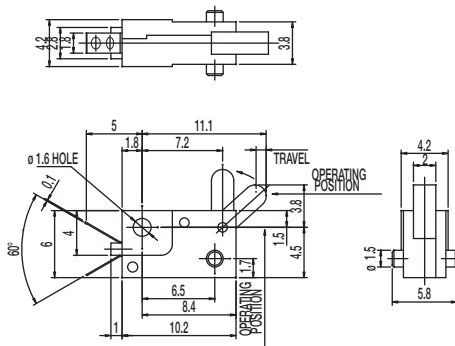

Specifications

CONTACT ARRANGEMENT: SPST, NO
 CONTACT RATING: 0.1A @ 16 VDC
 OPERATING LIFE: 20,000 cycles
 OPERATING FORCE: 30 \pm 15 gf
 TRAVEL: 0.90 \pm 0.20 mm
 INITIAL CONTACT RESISTANCE: 40 m Ω max.
 INSULATION RESISTANCE: 100 M Ω min. @ 250 VDC 60 sec.
 DIELECTRIC STRENGTH: 250 V AC (50-60Hz) 60 sec.
 OPERATING TEMPERATURE: -20°C to +70°C.

Materials

LEVER: POM
 CASE: PBT
 COVER: PC



Detect

DS Series Detect Switch



| PART NUMBER | PACKAGING | SCHEMATIC |
|---------------|--------------|-----------|
| DS-080 | 1,000 pieces | |

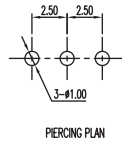
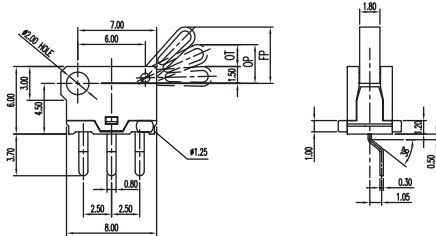
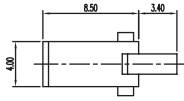

Specifications

CONTACT ARRANGEMENT: SPDT
 CONTACT RATING: 100mA @ 30 VDC
 OPERATING LIFE: 20,000 cycles
 OPERATING FORCE: 30 ± 20 gf
 OVER TRAVEL: 2.0 ± 0.40 mm
 INITIAL CONTACT RESISTANCE: 200 m Ω max.
 INSULATION RESISTANCE: 10 M Ω min. @ 250 VDC 60 sec.
 DIELECTRIC STRENGTH: 250 V AC (50-60Hz) 60 sec.
 OPERATING TEMPERATURE: -20°C to +70°C.

Materials

KNOB: POM
 COVER: PA46
 SLIDER: PBT
 HOUSING: PA46
 TERMINAL: Silver plated



| PART NUMBER | PACKAGING | SCHEMATIC |
|--------------------|--------------|-----------|
| DS-080-C PA | 1,000 pieces | |

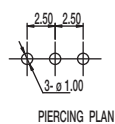
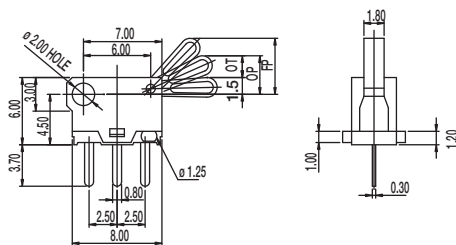
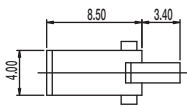

Specifications

CONTACT ARRANGEMENT: SPDT
 CONTACT RATING: 100mA @ 30 VDC
 OPERATING LIFE: 20,000 cycles
 OPERATING FORCE: 30 ± 20 gf
 OVER TRAVEL: 2.0 ± 0.40 mm
 INITIAL CONTACT RESISTANCE: 200 m Ω max.
 INSULATION RESISTANCE: 10 M Ω min. @ 250 VDC 60 sec.
 DIELECTRIC STRENGTH: 250 V AC (50-60Hz) 60 sec.
 OPERATING TEMPERATURE: -20°C to +70°C.

Materials

KNOB: POM
 COVER: PA46
 SLIDER: PBT
 HOUSING: PA46
 TERMINAL: Silver plated



Detect

DS Series Detect Switch



| PART NUMBER | PACKAGING | SCHEMATIC |
|-----------------------|------------|-----------|
| DS-09005-02 BK | 500 pieces | |

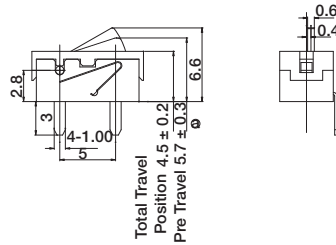
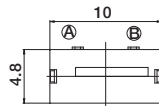

Specifications

CONTACT ARRANGEMENT: SPST
 CONTACT RATING: 1mA @ 5 VDC
 OPERATING LIFE: 100,000 cycles
 OPERATING FORCE: 50 gf max.
 TOTAL TRAVEL: 4.5±0.2 mm
 INITIAL CONTACT RESISTANCE: 500 m Ω max.
 INSULATION RESISTANCE: 100 M Ω min. @ 500 VDC 60 sec.
 DIELECTRIC STRENGTH: 500 V AC (50-60Hz) 60 sec.
 OPERATING TEMPERATURE: -20°C to +70°C.

Materials

LEVER: POM
 COVER: PA
 HOUSING: PA
 TERMINAL: Silver plated



| PART NUMBER | PACKAGING | SCHEMATIC |
|-----------------------|------------|-----------|
| DS-09005-02 RP | 500 pieces | |

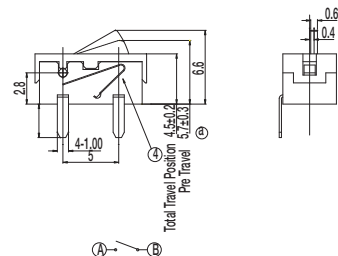
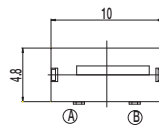

Specifications

CONTACT ARRANGEMENT: SPST
 CONTACT RATING: 1mA @ 5 VDC
 OPERATING LIFE: 100,000 cycles
 OPERATING FORCE: 50 gf max.
 TOTAL TRAVEL: 4.5±0.2 mm
 INITIAL CONTACT RESISTANCE: 500 m Ω max.
 INSULATION RESISTANCE: 100 M Ω min. @ 500 VDC 60 sec.
 DIELECTRIC STRENGTH: 500 V AC (50-60Hz) 60 sec.
 OPERATING TEMPERATURE: -20°C to +70°C.

Materials

LEVER: POM
 COVER: PA
 HOUSING: PA
 TERMINAL: Silver plated



Detect

HDS Series Micro Mini Side Actuated Surface Mount Detect Switches

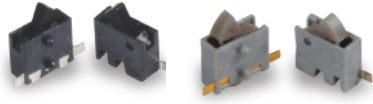

Features/Benefits

- Low profile package sits just 1.4 mm off PCB
- Design allows top or side actuation
- Right and left options available
- Low actuation force, 30 grams max.
- Pick and place compatible, available in tape & reel packaging
- RoHS compliant and compatible

Typical Applications

- Consumer electronics
- Computers
- Medical devices
- Mobile Communications
- ATCA and MicroTCA devices

Specifications

CONTACT RATING: 1 mA 5 VDC
 MECHANICAL AND ELECTRICAL LIFE: 100,000 cycles min.
 CONTACT RESISTANCE: 1 Ω max. initial.
 INSULATION RESISTANCE: 100 M Ω min. between adjacent contacts.
 OPERATING TEMPERATURE: -40°C to + 80°C
 STORAGE TEMPERATURE: -40°C to + 80°C
 PACKAGING: tape & reel; 5,000 per reel.
 TRAVEL:
 Pre-travel: .17 mm min.
 Overtravel: .5 mm min.
 Total: 1.07 mm

Materials

BASE: LCP HDS001L: Gray HDS001R: Black
 COVER: PA 46 (UL94V-0)
 ACTUATOR: PA 46 (UL94V-0) HDS001L: Gray HDS001R: Black
 MOVABLE BLADE: Stainless Steel, Ag over Ni plating.
 TERMINALS: Phosphor Bronze, Ag plating.

NOTE: Specifications and materials listed above are for switches with standard options. For information on specific and custom switches, consult Customer Service Center.

Build-A-Switch

Complete part numbers for HDS Series are shown below.

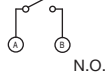
| PART NUMBER | PACKAGING | SCHEMATIC |
|----------------|-------------|---|
| HDS001R | TAPE & REEL |  |

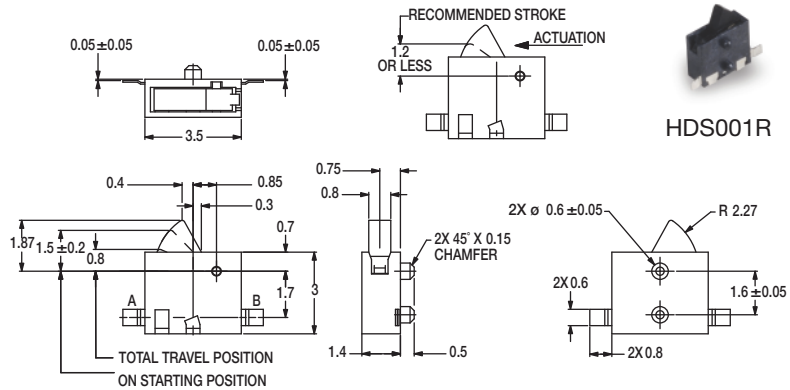
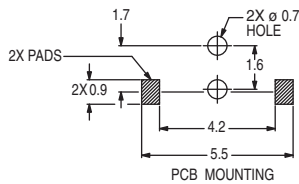

HDS001R

HDS001L

| PART NUMBER | PACKAGING | SCHEMATIC |
|----------------|-------------|---|
| HDS001L | TAPE & REEL |  |

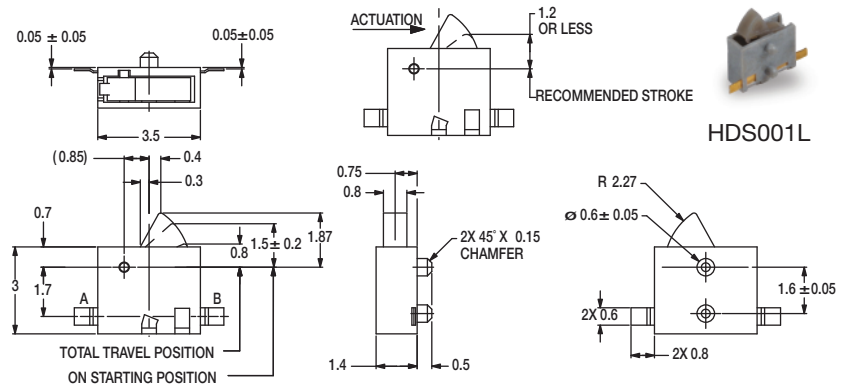
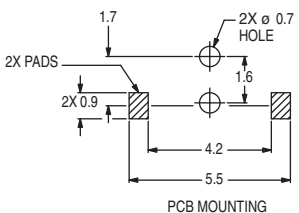

Third Angle Projection

Dimensions are shown: mm
 Specifications and dimensions subject to change



HDS Series Micro Mini Side Actuated Surface Mount Detect Switches

TAPE & REEL

HDS001R

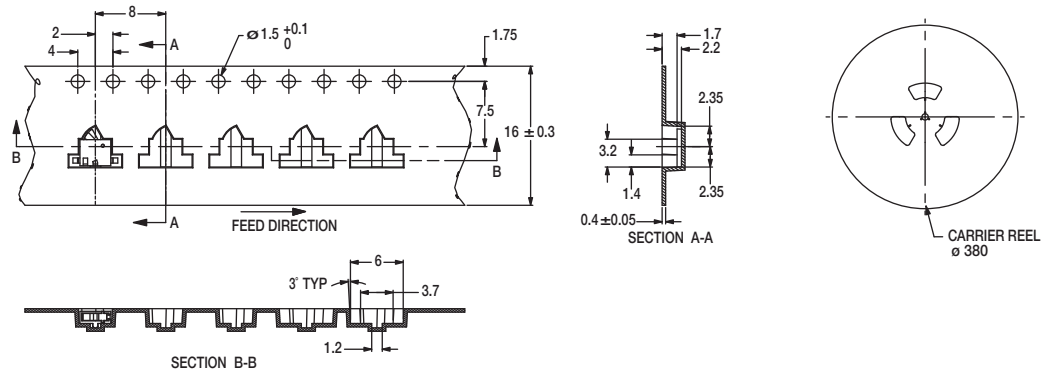

HDS001L

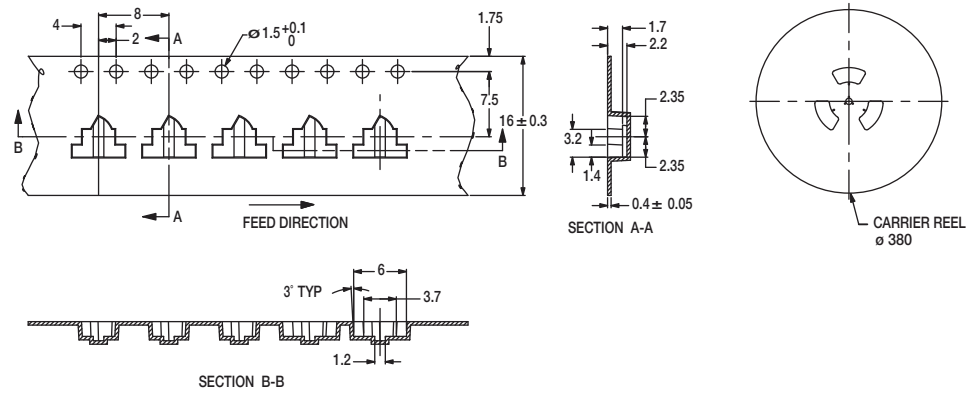

NOTE: Quantity per reel: 5,000 pieces



Detect

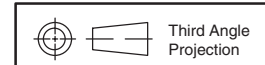

Third Angle Projection
Dimensions are shown: mm
Specifications and dimensions subject to change

HDP Series Micro Mini Side Actuated Surface Mount Detect Switches



Features/Benefits

- Low profile
- Side actuation
- Right and left options available
- Low actuation force
- Lead free and halogen free

Typical Applications

- Consumer electronics
- Computers
- Medical devices
- Mobile Communications
- ATCA and MicroTCA devices

Specifications

CONTACT RATING: 1 mA 5 VDC
 MECHANICAL AND ELECTRICAL LIFE: 100,000 cycles min.
 CONTACT RESISTANCE: < 500 m Ω initial.
 INSULATION RESISTANCE: > 100 M Ω
 OPERATING TEMPERATURE: -20°C to + 70°C
 STORAGE TEMPERATURE: -30°C to + 80°C
 PACKAGING: tape & reel; 2,500 per reel.
 TRAVEL:
 Pre-travel 0.15 mm min.
 "ON" starting position 2.96 +/- 0.25 mm
 Total: 1.3 mm
 Mechanical: 1.9 mm

Materials

BASE: PA 46 (UL94HB) - halogen free
 ACTUATOR: PA 46 (UL94HB) - halogen free
 HDP001R - black body/actuator
 HDP001L - grey body/actuator
 MOVABLE CONTACTS: Stainless Steel, Silver over nickel plate.
 FIXED CONTACTS/TERMINALS: Phosphor Bronze, Silver plate.

NOTE: Specifications and materials listed above are for switches with standard options. For information on specific and custom switches, consult Customer Service Center.

Build-A-Switch

Complete part numbers for HDP Series are shown below.



| PART NUMBER | PACKAGING | SCHEMATIC |
|-------------------------|-------------|-----------|
| HDP001R | TAPE & REEL | |
| Black body/ actuator | | |

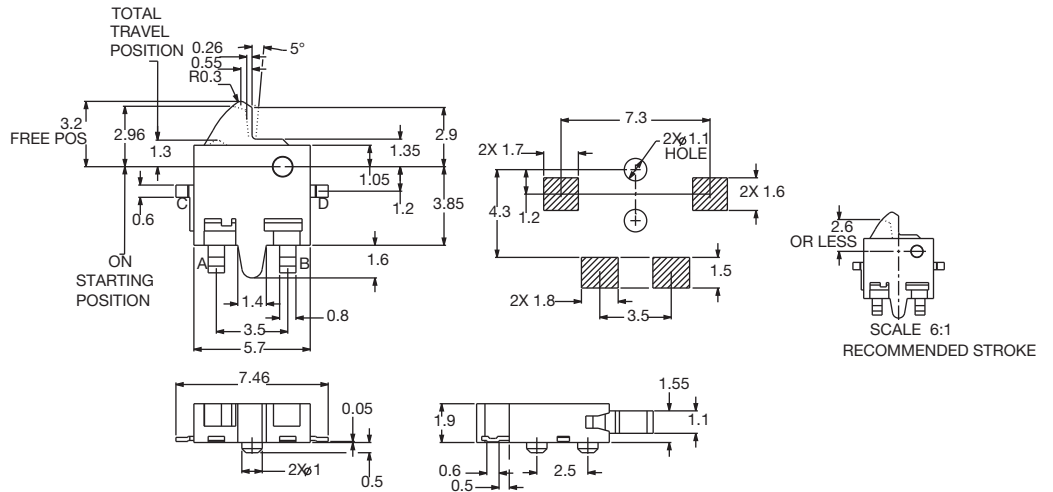

Detect

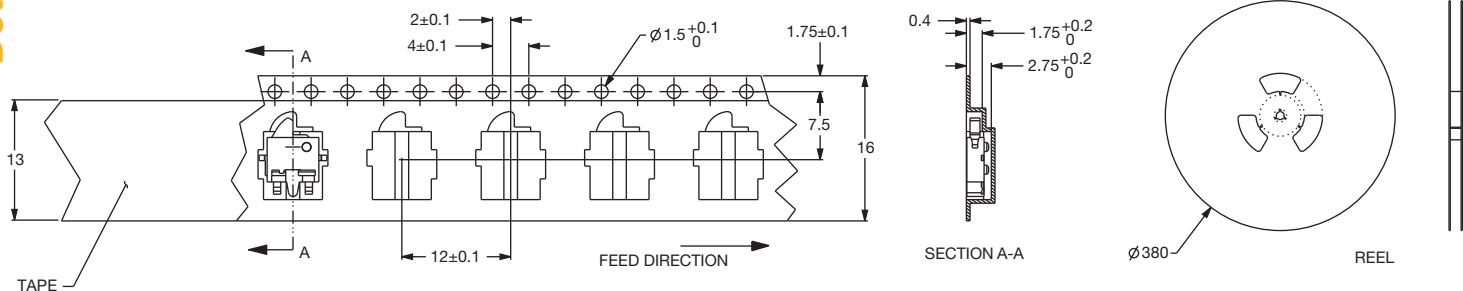

Dimensions are shown: mm
 Specifications and dimensions subject to change

HDP Series Micro Mini Side Actuated Surface Mount Detect Switches



| PART NUMBER | PACKAGING | SCHEMATIC |
|------------------------|-------------|-----------|
| HDP001L | TAPE & REEL | |
| Grey body/ actuator | | |

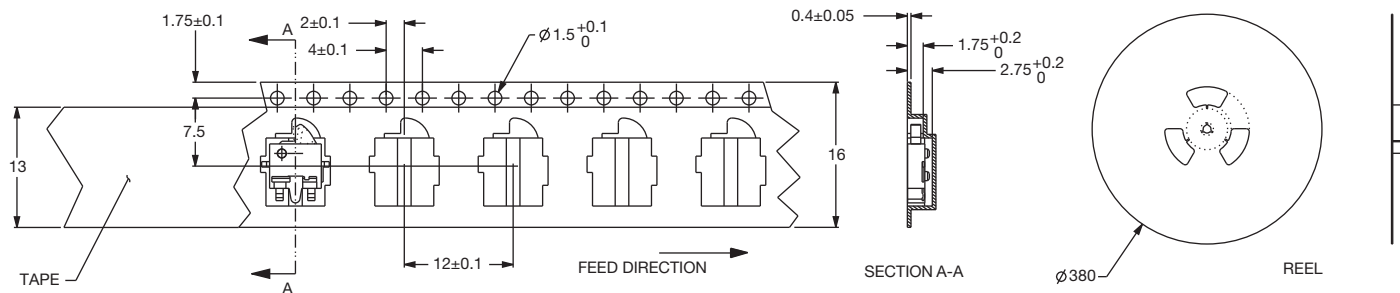
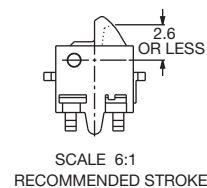
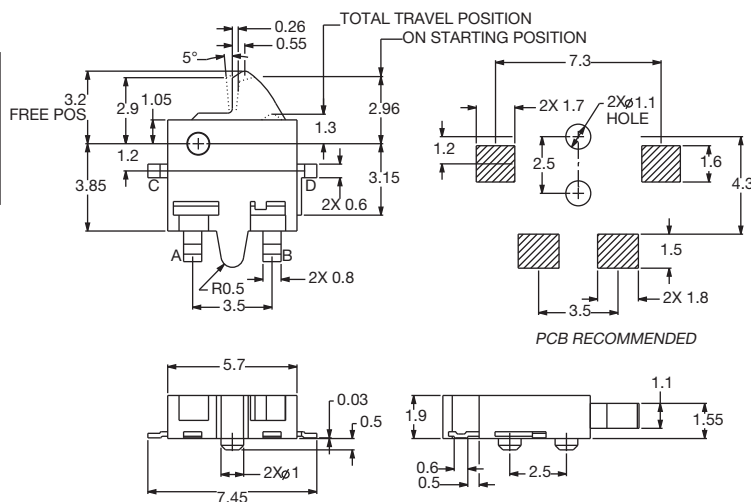

SDP Series Micro Mini Pendulum SMT Detect Switch



Features/Benefits

- SMT process compatible
- Low profile
- Right or left side actuated
- Low actuation force
- Low halogen / halogen free

Typical Applications

- Consumer electronics
- Computers
- Medical devices
- ATCA and MicroTCA devices

Specifications

CONTACT RATING: 5 VDC 1mA (0.1mA to 100mA max)
 MECHANICAL AND ELECTRICAL LIFE: 50,000 cycles
 CONTACT RESISTANCE: 500 m Ω max. initial.
 INSULATION RESISTANCE: 100 M Ω (500VDC for 1 min.)
 OPERATING TEMPERATURE: -20°C to + 70°C
 STORAGE TEMPERATURE: -30°C to + 80°C
 PACKAGING: Tape & reel 4,550 pieces

Materials

BASE: LCP (black)
 COVER: PA 46 (black)
 ACTUATOR: LCP (black)
 MOVABLE BLADE: Stainless Steel, Ag over Ni plating.
 TERMINALS: Phosphor Bronze, Ag over Ni plating.
 SOLDERABILITY: Lead free compatible - No clean.

NOTE: Specifications and materials listed above are for switches with standard options. For information on specific and custom switches, consult Customer Service Center.

Build-A-Switch

Complete part numbers for SDP Series are shown below.

SDP002

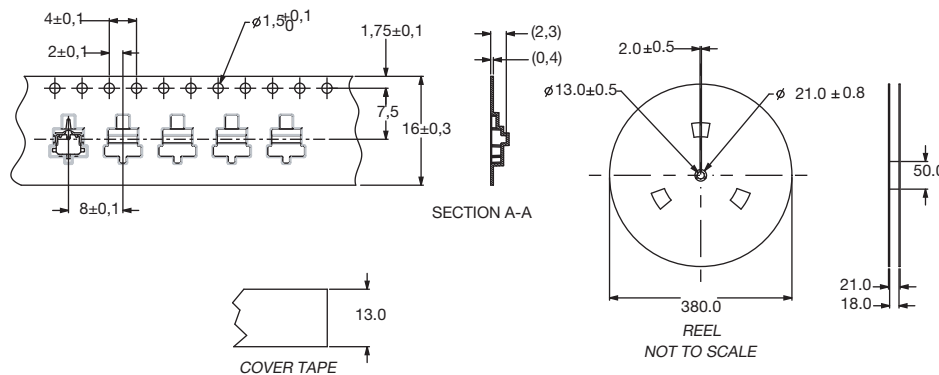
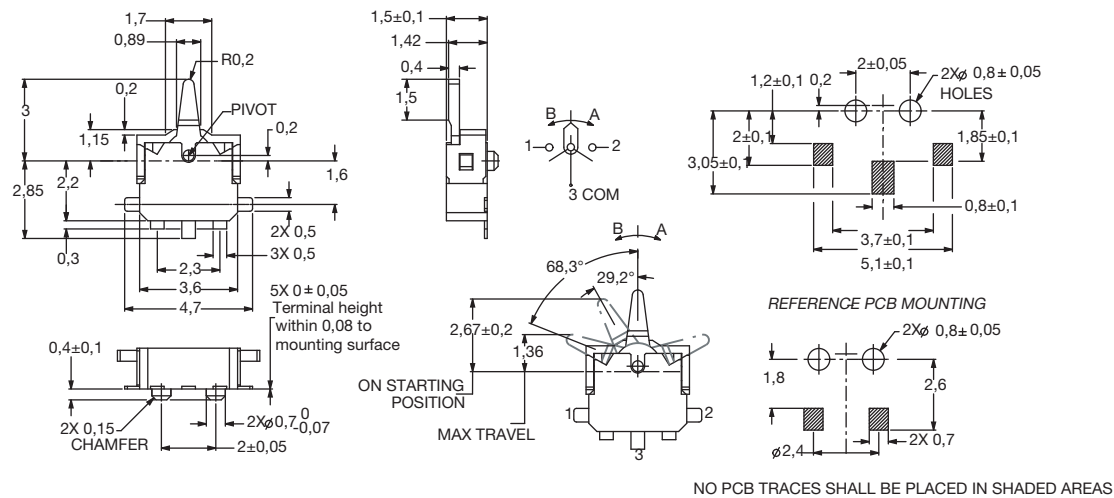

Detect



Dimensions are shown: mm
 Specifications and dimensions subject to change

SDS Series Side Actuated Detect Switches

Features/Benefits

- Low profile package sits just 2mm off PCB
- 2mm overtravel ideal for detector applications
- Low actuation force (75 grams max.)
- Pick & place compatible, available in tape & reel packaging
- RoHS compliant and compatible

Typical Applications

- Medical devices
- Consumer electronic devices
- PCB lock cam detect
- Smart card detect
- ATCA and MicroTCA



Specifications

CONTACT RATING: 100 mA @ 12 VDC.
 MECHANICAL & ELECTRICAL LIFE: 50,000 cycles.
 CONTACT RESISTANCE: 100 m Ω max. initial.
 INSULATION RESISTANCE: 10 M Ω min. @ 100 VDC.
 OPERATING TEMPERATURE: -40°C to +85°C.
 SOLDERABILITY: IR compatible, no wash. 260°C max.
 PACKAGING: Bulk or tape & reel (3000 per reel).

Materials

BASE: Glass filled LCP (UL 94V-0).
 ACTUATOR: Glass Filled LCP (UL94V-0).
 SURFACE PLATE: Nickel silver w/silver plate.
 MOVABLE CONTACT: Phosphor bronze, see table for plating.
 TERMINALS: Phosphor bronze, see table for plating.

NOTE: Specifications and materials listed above are for switches with standard options. For information on specific and custom switches, consult Customer Service Center.

How to Order

Complete part numbers for SDS Series Switches are shown below.

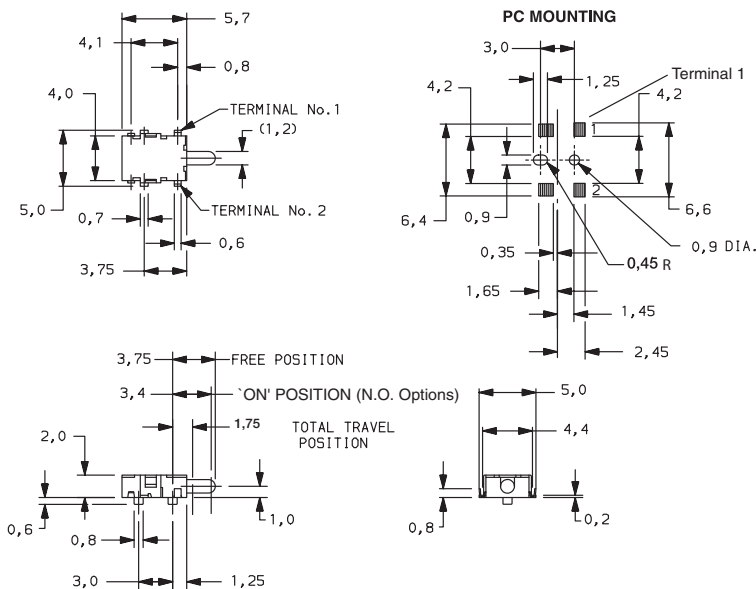

| PART NUMBER | HOUSING COLOR | PACKAGING | SCHEMATIC | Contact Plating | Terminal Plating |
|-------------|---------------|-------------|-----------|-----------------|------------------|
| SDS001 | Black | Bulk | N.O. 2 1 | Silver Clad | Silver Plate |
| SDS001R | | Tape & Reel | | | |
| SDS002 | White | Bulk | N.C. 2 1 | Gold Flash | Gold Flash |
| SDS002R | | Tape & Reel | | | |
| SDS004 | Black | Bulk | N.O. 2 1 | Gold Flash | Gold Flash |
| SDS004R | | Tape & Reel | | | |
| SDS005 | White | Bulk | N.C. 2 1 | Gold Flash | Gold Flash |
| SDS005R | | Tape & Reel | | | |



SDS001
SPST

TAPE & REEL

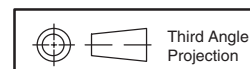
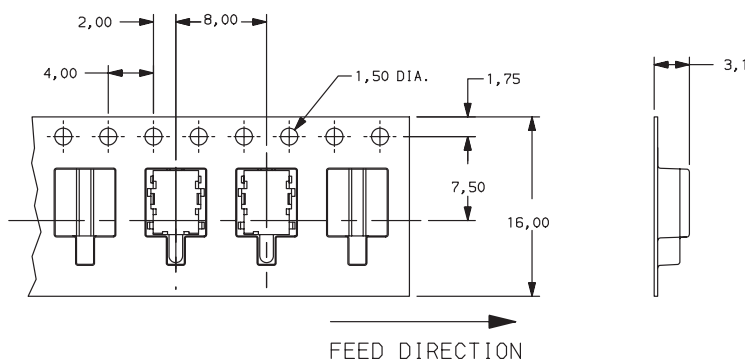

Dimensions are shown: mm
 Specifications and dimensions subject to change



Detect

DDS Series Micro Mini Thru-hole Detect Switches



Features/Benefits

- Vertical or horizontal actuation
- 2mm overtravel—Ideal for detector applications
- Low actuations force (less than 40 grams)
- RoHS compliant and compatible

Typical Applications

- Detect the presence of a mechanical device
- Medical devices
- Consumer electronic devices

Specifications

CONTACT RATING: 0.1A @ 30 VDC.
 MECHANICAL & ELECTRICAL LIFE: 50,000 cycles.
 CONTACT RESISTANCE: 150 m Ω max. initial.
 INSULATION RESISTANCE: 100 M Ω min. @ 100 VDC.
 OPERATING TEMPERATURE: -20°C to +70°C.
 DIELECTRIC STRENGTH: 100 volts AC @ 60 Hz.
 PACKAGING: Bulk.

Materials

HOUSING: P.P.S.
 ACTUATOR: PA66
 MOVABLE CONTACT: Tin bronze, silver plated.

NOTE: Specifications and materials listed above are for switches with standard options. For information on specific and custom switches, consult Customer Service Center.

How To Order

Complete part numbers for DDS Series Switches are shown below.



DDS001
SPST

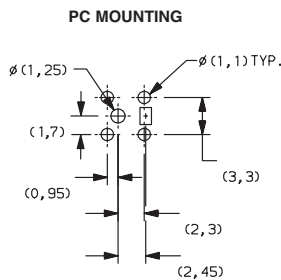
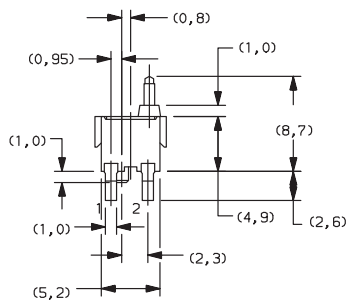
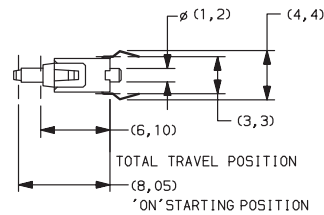
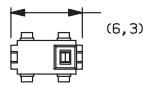

| PART NUMBER | DESCRIPTION | SCHEMATIC |
|-------------|-------------------|---------------|
| DDS001 | Vertical Actuator | SPST N.O. |



Detect

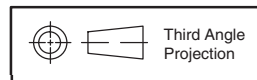

Dimensions are shown: mm
 Specifications and dimensions subject to change

DDS Series Micro Mini Thru-hole Detect Switches



| PART NUMBER | DESCRIPTION | SCHEMATIC |
|---------------|-----------------------------|--|
| DDS002 | Right angle, actuator right |  SPST N.O. |

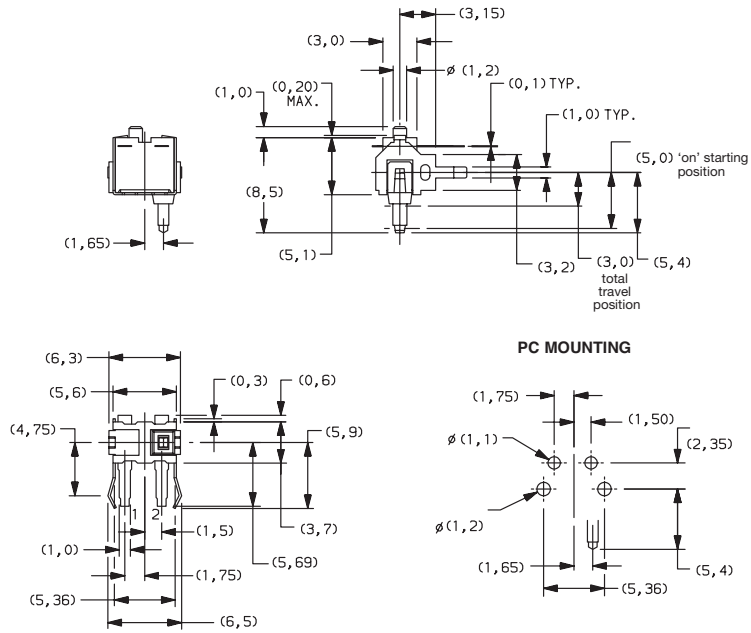

**DDS002
SPST**

| PART NUMBER | DESCRIPTION | SCHEMATIC |
|---------------|----------------------------|--|
| DDS003 | Right angle, actuator left |  SPST N.O. |

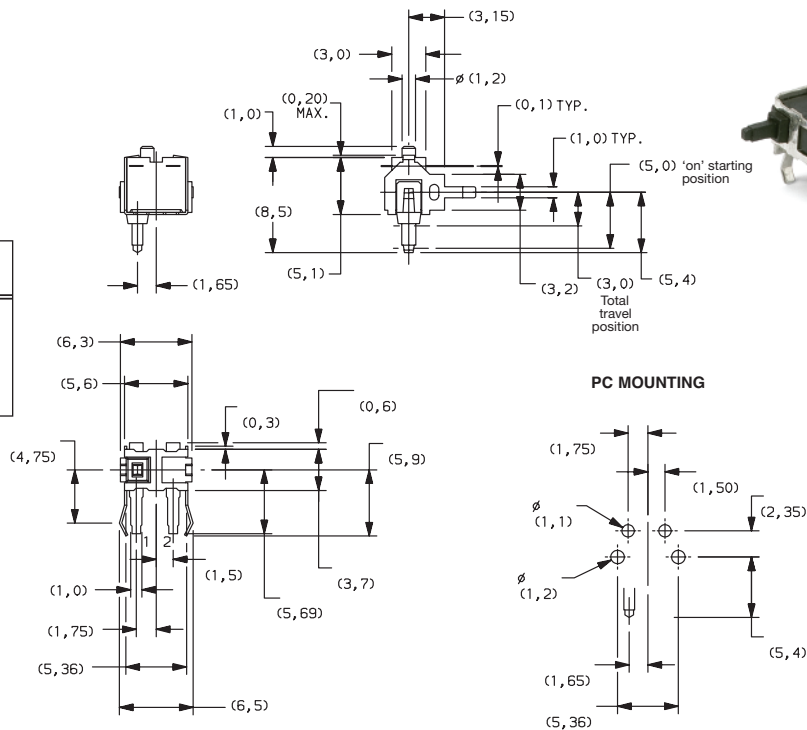

Detect

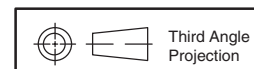

Third Angle Projection
Dimensions are shown: mm
Specifications and dimensions subject to change

MDS Series Micro Snap-acting Detect Switches

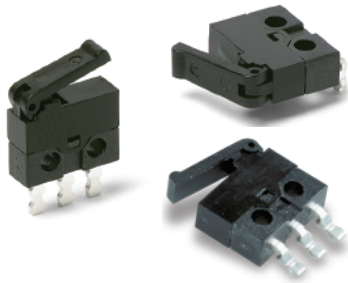

Features/Benefits

- Snap-acting tactile feel
- Small package size
- Available in vertical or right angle PCB mount
- RoHS compliant and compatible

Typical Applications

- Detect the presence of a mechanical device
- Medical devices
- Consumer electronic devices
- ATCA or MicroTCA devices

Specifications

CONTACT RATING: 300mA @ 30 VDC.
 MECHANICAL & ELECTRICAL LIFE: 30,000 operations.
 CONTACT RESISTANCE: 100 m Ω max.
 OPERATING TEMPERATURE: -25°C to +70°C.
 SOLDERABILITY: According to lead free solder profiles.
 PACKAGING: Available in bulk or tape and reel.
 OPERATING FORCE: 50 g Max.
 RELEASE FORCE: 3g Min.

Materials

BASE: PA9T
 COVER & ACTUATOR: PA9T
 MOVABLE CONTACT: Copper alloy, silver plated.
 STATIONARY CONTACTS: Copper alloy, silver plated.
 TERMINALS: Copper alloy, silver plated.

NOTE: MDS series is RoHS compliant, and compatible. See technical data section of this catalog for RoHS compliant and compatible definitions and specifications.

NOTE: Specifications and materials listed above are for switches with standard options. For information on specific and custom switches, consult Customer Service Center.

Build-A-Switch

To order, simply select desired option from each category and place in the appropriate box. Available options are shown and described on pages E-21 and E-25. For additional options not shown in catalog, consult Customer Service Center.

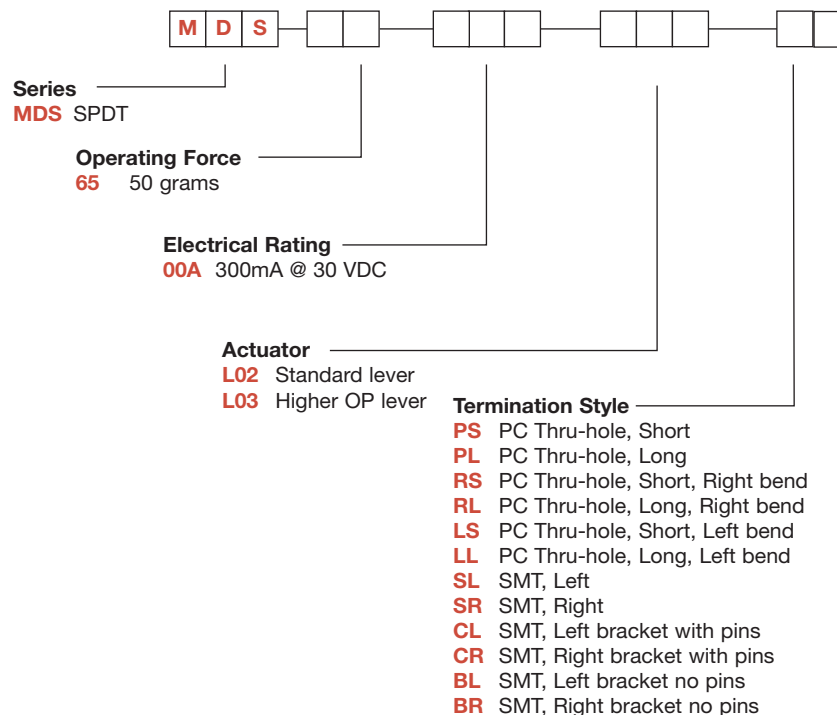

Detect

MDS Series Micro Snap-acting Detect Switches

SERIES **MDS**

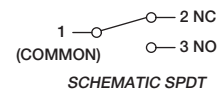
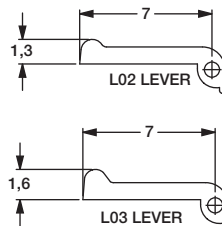
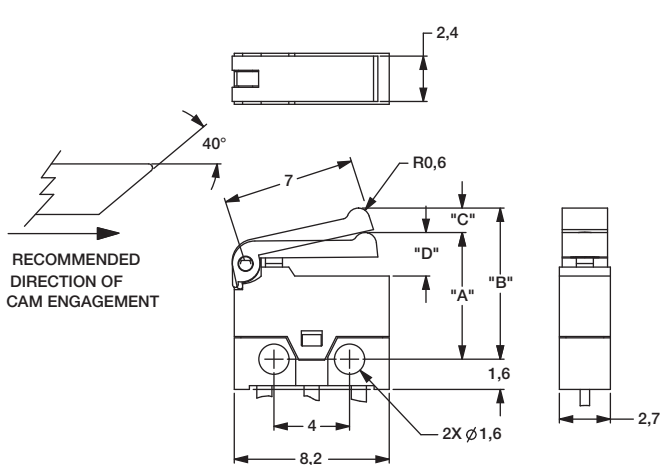

| OPERATING CHARACTERISTICS | | | |
|---------------------------|---------|-----------------|-----------------|
| | | LEVER L02 | LEVER L03 |
| OPERATING POSITION | DIM 'A' | 6.7 ± 0.5 | 7.0 +/- 0.5 |
| FREE POSITION | DIM 'B' | 8 MAX | 8.5 MAX |
| PRETRAVEL | DIM 'C' | 1,8 MAX | 1,8 MAX |
| OVER TRAVEL | DIM 'D' | 0,3 MIN | 0,3 MIN |
| CONTACT RATING | | 0,3A @ 30 VDC | 0,3A @ 30VDC |
| OPERATING FORCE | | 50 GRAMS F. MAX | 50 GRAMS F. MAX |

OPERATING FORCE

| OPTION CODE | OPERATING FORCE |
|-------------|-----------------|
| 65 | 50 grams max. |

ELECTRICAL RATING

| OPTION CODE | ELECTRICAL RATING |
|-------------|-------------------|
| 00A | 300mA @ 30 V DC |

ACTUATOR

L02 STANDARD LEVER

L03 HIGHER OP LEVER

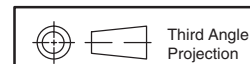
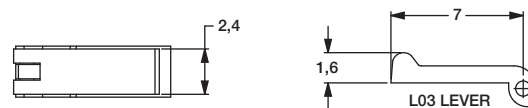
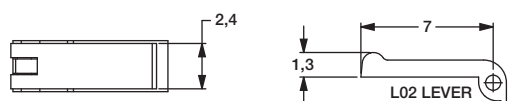

Dimensions are shown: mm
Specifications and dimensions subject to change

C&K



MDS Series Micro Snap-acting Detect Switches

TERMINATIONS

PCB Mounting Pattern

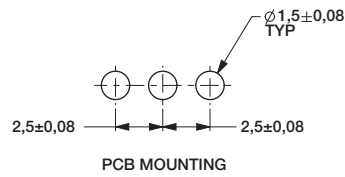

PS PC THRU-HOLE, SHORT STRAIGHT

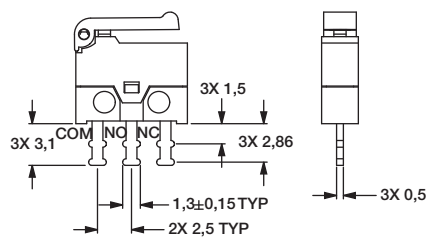

PL PC THRU-HOLE, LONG STRAIGHT

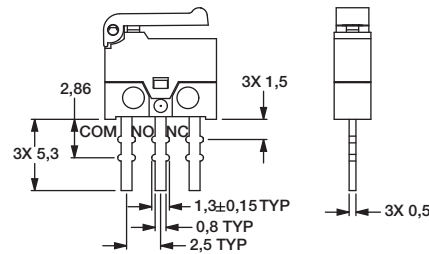

RS PC THRU-HOLE, SHORT RIGHT BEND

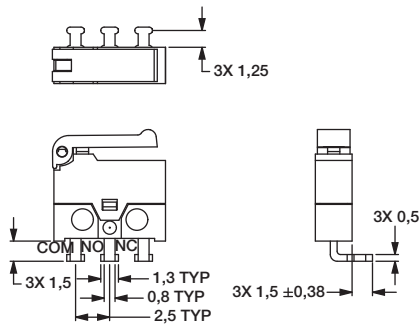

RL PC THRU-HOLE, LONG SHORT BEND

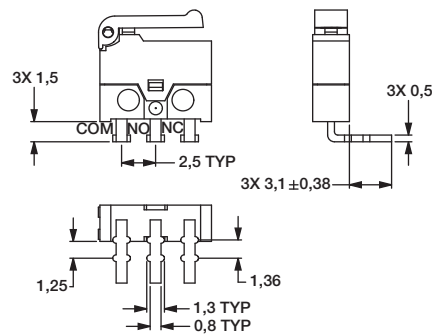

LS PC THRU-HOLE, SHORT LEFT BEND

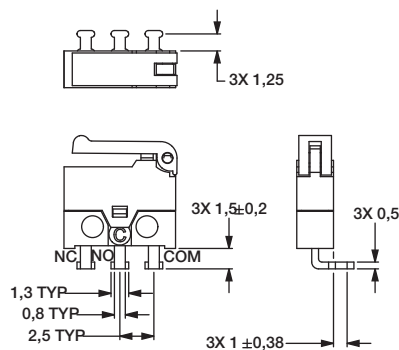

LL PC THRU-HOLE, LONG LEFT BEND

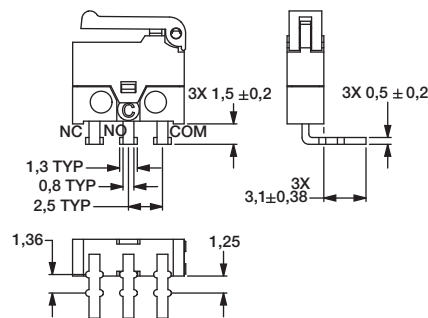

Detect

MDS Series Micro Snap-acting Detect Switches

TERMINATIONS

SL SMT, LEFT MOUNT

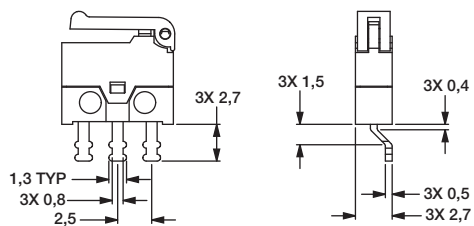

SMT Mounting Pattern

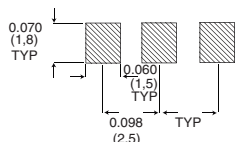

SR SMT, RIGHT MOUNT

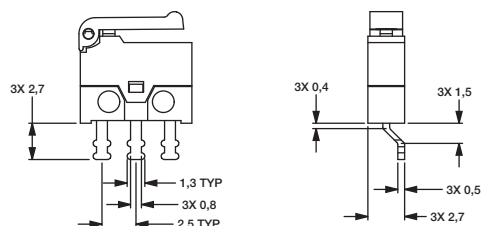

SMT Mounting Pattern

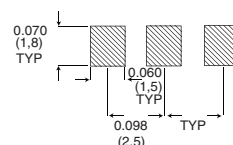

CL SMT, LEFT BRACKET WITH PINS

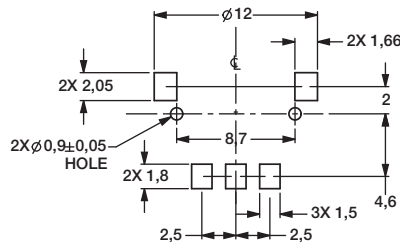
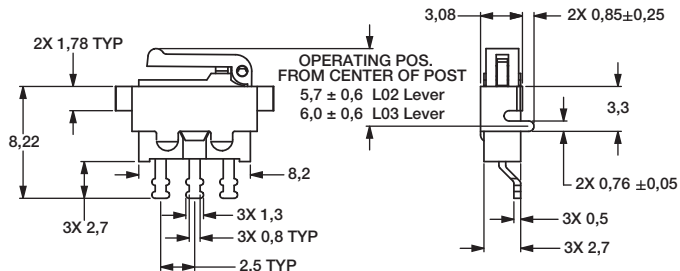
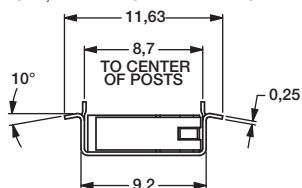

CR SMT, RIGHT BRACKET WITH PINS

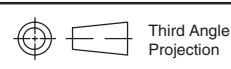
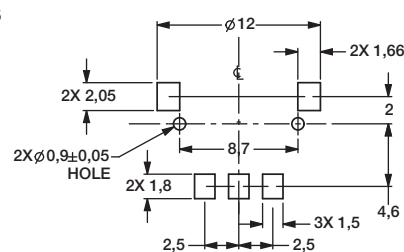
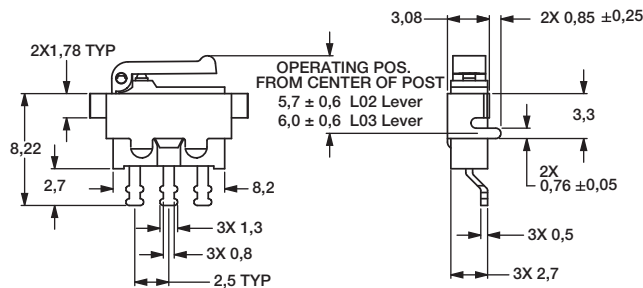
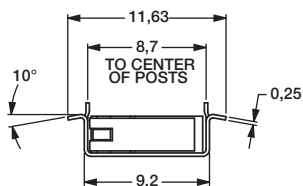

Third Angle Projection

Dimensions are shown: mm
Specifications and dimensions subject to change



Detect

MDS Series Micro Snap-acting Detect Switches

TERMINATIONS



BL SMT, LEFT BRACKET NO PINS

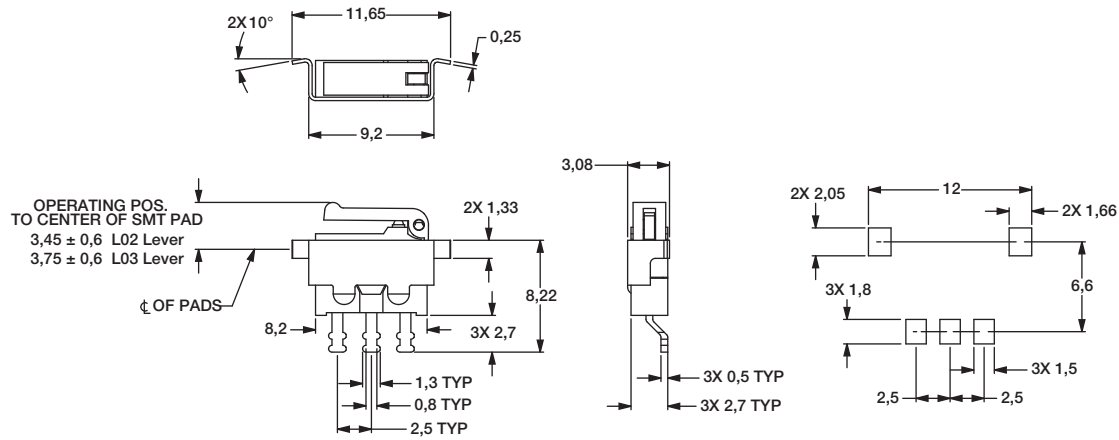

BR SMT, RIGHT BRACKET NO PINS

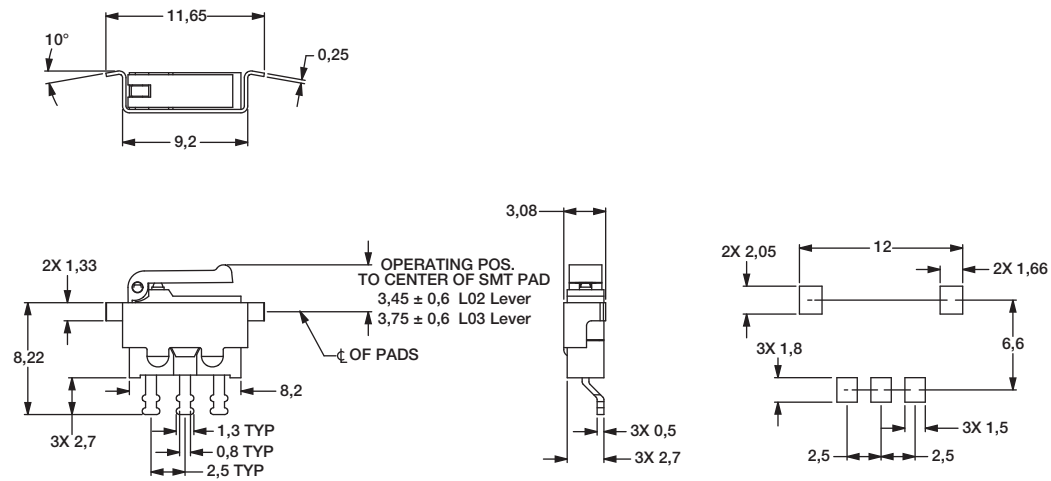

Detect

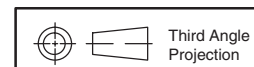

Third Angle
Projection

Dimensions are shown: mm
Specifications and dimensions subject to change

MDS Series Micro Snap-acting Detect Switches

TAPE & REEL

SL SMT, LEFT MOUNT

SR SMT, RIGHT MOUNT

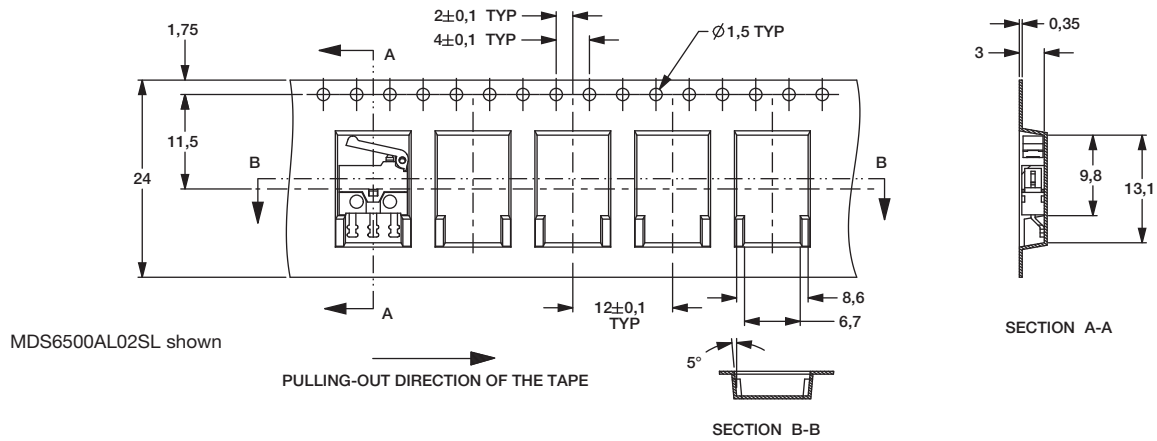

CL SMT, LEFT MOUNT

CR SMT, RIGHT MOUNT

BL SMT, LEFT MOUNT

BR SMT, RIGHT MOUNT

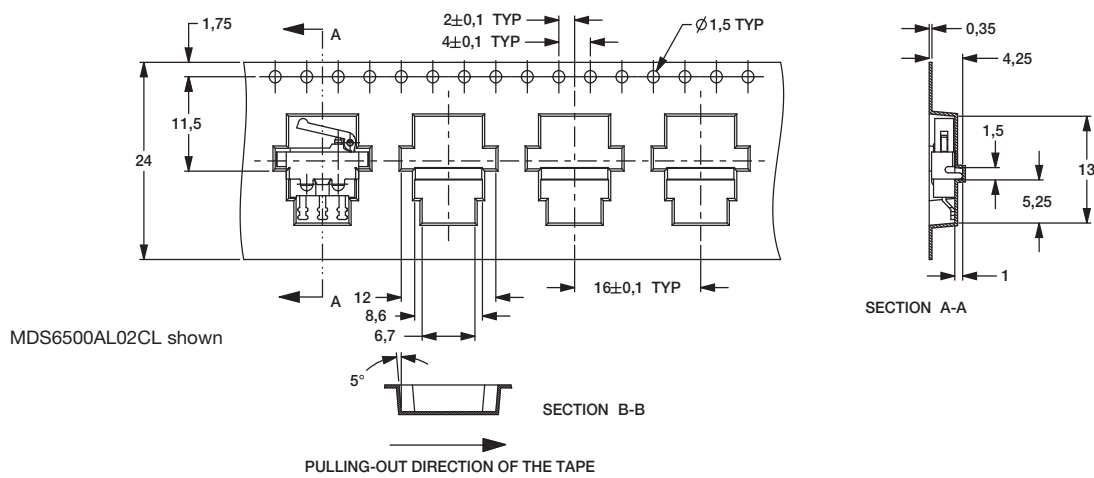

Supplied in carrier tape meeting the EIA-481-2 standard for 24mm tape.

Packaging quantity: SL and SR; 1,600 pieces per reel
CL, CR, BL and BR; 1,000 pieces per reel

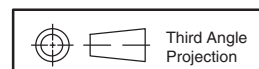

Third Angle
Projection
Dimensions are shown: mm
Specifications and dimensions subject to change

www.ck-components.com



E

Detect

KDS Series Intrusion Switches

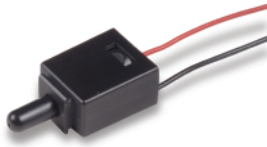

Features/Benefits

- Slot mount into chassis to reduce installation cost
- Wire harness length & connector easily customized
- Available in N.O. or N.C. configuration
- RoHS compliant

Typical Applications

- Intrusion/Alarm switch in network desktop PC
- Intrusion/Alarm switch in telecommunication equipment
- Intrusion/Alarm switch in cellular base station

Specifications

CONTACT RATING: 0.4 VA max. @ 20 V AC or DC.
 MECHANICAL & ELECTRICAL LIFE: 10,000 actuations min. at full load.
 CONTACT RESISTANCE: 200 m Ω max. initial @ 2-4 V DC, 100mA.
 INSULATION RESISTANCE: 10⁹ Ω min.
 OPERATING TEMPERATURE: -40°C to +85°C
 TRAVEL: KDS11: Pre-travel 0.180" TYP; Overtravel 0.223"
 KDS33: No pre-travel, full travel 0.403"
 DIELECTRIC STRENGTH: 500 Vrms min. @ sea level.
 PACKAGING: Bulk packaging.

Materials

HOUSING: Nylon 6/6 (UL 94V-0)
 ACTUATOR: Nylon 6/6 (UL 94V-0)
 MOVABLE CONTACT: Copper alloy, gold plate over nickel plate.
 FIXED CONTACT: Brass, gold plate over nickel plate.
 WIRE: UL 1061-24 AWG.

NOTE: Specifications and materials listed above are for switches with standard options. For information on specific and custom switches, consult Customer Service Center.

How To Order

Complete part numbers for KDS Series Switches are shown below.

| PART NUMBER | SWITCH FUNCTION | | SCHEMATIC |
|--------------|-----------------|--------|-----------|
| | POS. 1 | POS. 2 | |
| KDS11 | OFF | MOM. | SPST N.O. |
| KDS33 | ON | OFF | SPST N.C. |

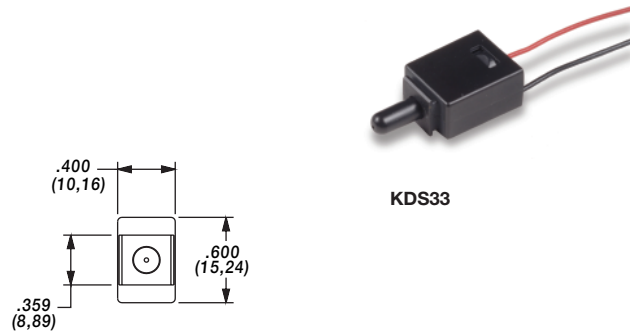

Detect

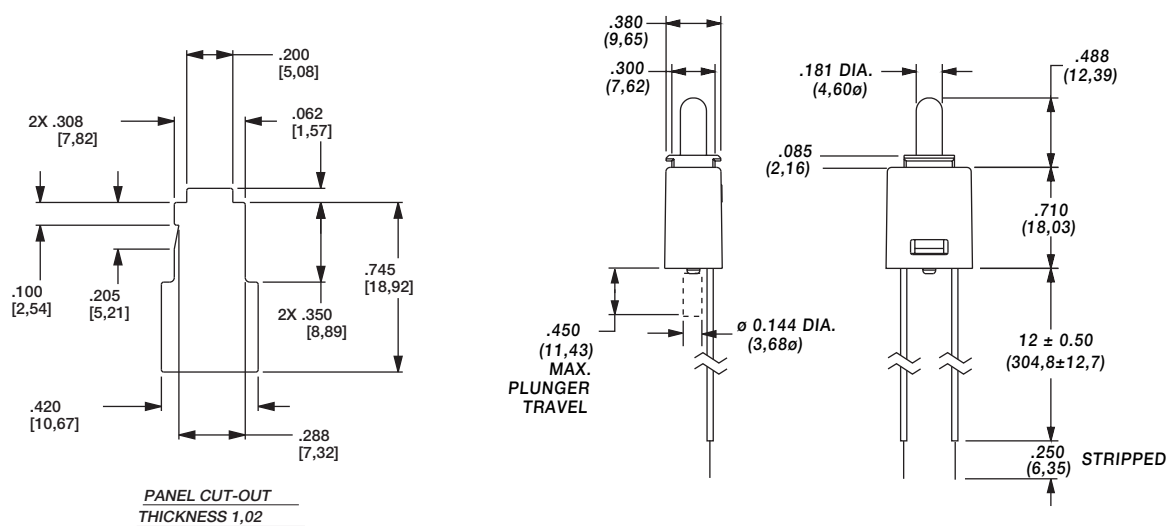

KM Series Subminiature Detect Switches

Features/Benefits

- **Reliable contact design**
- **Available with pretravel and overtravel**
- **RoHS compliant**

Typical Applications

- **Alarm systems**
- **Computers**
- **Detector switch application**

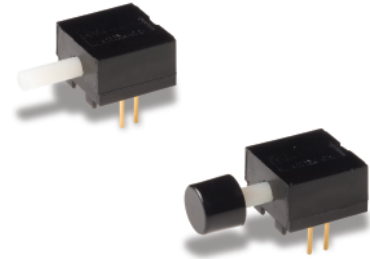

Models Available

Specifications

CONTACT RATING: Q contact material:
0.25 AMPS @ 125 V AC or DC (UL). See page F-29 for additional ratings.

ELECTRICAL LIFE: 10,000 actuations min. at full load.

CONTACT RESISTANCE: Below 30 mΩ typ. initial @ 2-4 V DC, 100 mA, for both silver and gold plated contacts.

INSULATION RESISTANCE: 10⁹Ω min.

DIELECTRIC STRENGTH: 1,000 Vrms min. @ sea level.

OPERATING TEMPERATURE: -30°C to 85°C.

CAP INSTALLATION FORCE: 10 lbs. max. permissible.

NOTE: Any models supplied with Q or B contact material are RoHS compliant.

NOTE: Specifications and materials listed above are for switches with standard options. For information on specific and custom switches, consult Customer Service Center.

Materials

HOUSING & BUSHING: 6/6 nylon (UL94V-2), black.

ACTUATOR: 6/6 nylon (UL 94V-2), natural.

MOVABLE CONTACT: B contact material: Bronze or copper, with gold plate over nickel plate. See page F-39 for additional contact materials.

STATIONARY CONTACTS & TERMINALS: B contact material: Copper, with gold plate over nickel plate. See page F-29 for additional contact materials.

RETURN SPRING: Music wire, phosphor coated.

MOUNTING NUT: Brass, nickel plated.

TERMINAL SEAL: Epoxy.

Build-A-Switch

To order, simply select desired option from each category and place in the appropriate box. Available options are shown and described on pages E-28 and E-29. For additional options not shown in catalog, consult Customer Service Center.

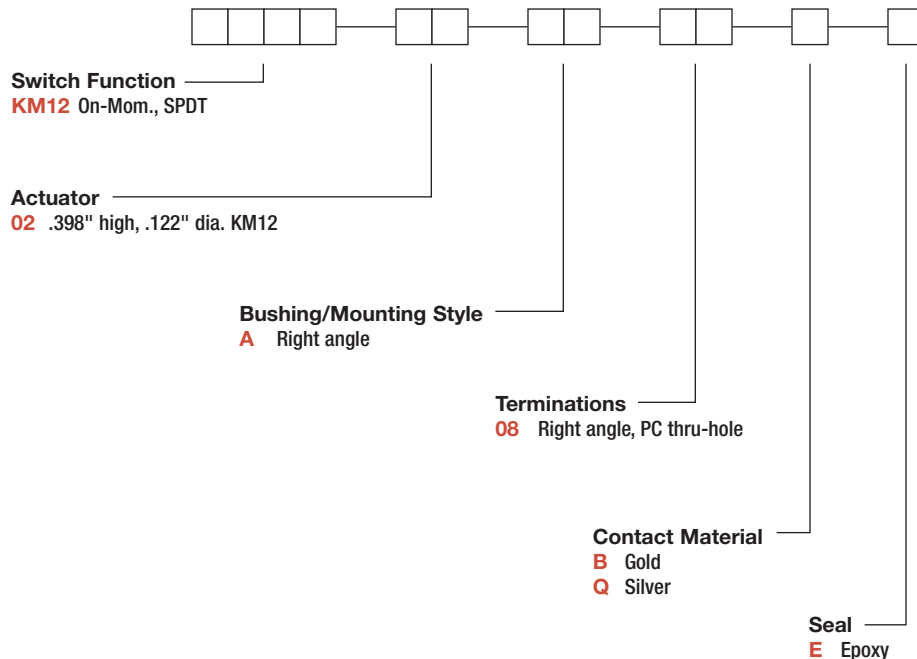

Detect



Dimensions are shown: mm
Specifications and dimensions subject to change

KM Series Subminiature Detect Switches

SWITCH FUNCTION



| NO. POLES | MODEL NO. | SWITCH FUNCTION | | CONNECTED TERMINALS | | SCHEMATIC |
|-----------|-------------|-----------------|--------|---------------------|--------|-----------|
| | | POS. 1 | POS. 2 | POS. 1 | POS. 2 | |
| SP | KM12 | ON | MOM. | 2-1 | 4-3 | SPDT |

SPDT

Part number shown: KM1202A08BE

ACTUATOR



02 .398" HIGH, .122" DIA.

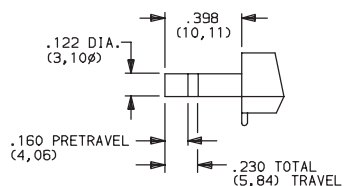

NOTE: Caps available for plunger options, see page E-29.

BUSHING/ MOUNTING STYLE



A RIGHT ANGLE

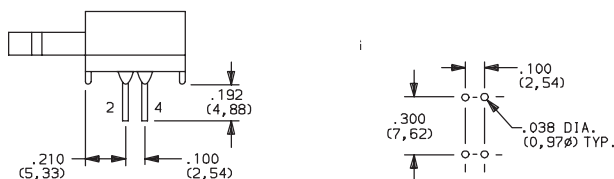

TERMINATIONS



08 RIGHT ANGLE, PC THRU-HOLE

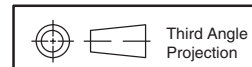
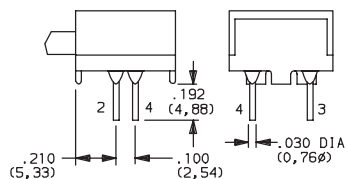

Third Angle Projection

Dimensions are shown: mm
Specifications and dimensions subject to change



E

Detect

KM Series Subminiature Detect Switches

CONTACT MATERIAL

| OPTION CODE | RoHS COMPLIANT * | RoHS COMPATIBLE * | CONTACT AND TERMINAL MATERIAL | RATINGS | |
|-------------|------------------|-------------------|-------------------------------|-----------------------|---|
| | | | | | |
| B | YES | YES | GOLD ¹ | LOW LEVEL/DRY CIRCUIT | 0.4 VA MAX. @ 20 V AC OR DC MAX. |
| Q | YES | YES | SILVER ² | POWER | 0.25 AMPS @ 125 V AC OR DC (KM11, KM12) (UL) 1 AMP @ 125 V AC OR 28 V DC (KM33). |

* Note: See Technical Data section of this catalog for RoHS compliant and compatible definitions and specifications.

¹ STATIONARY CONTACTS & TERMINALS: Copper, with gold plate over nickel plate.
MOVABLE CONTACT: Phosphor bronze or beryllium copper, with gold plate over nickel plate.

² STATIONARY CONTACTS & TERMINALS: Copper, silver plated (standard with all termination options).
MOVABLE CONTACT: Phosphor bronze or beryllium copper, silver plated.

³ STATIONARY CONTACTS & TERMINALS: Copper, with gold plate over nickel plate over silver plate.
MOVABLE CONTACT: Phosphor bronze or beryllium copper, with gold plate over nickel plate over silver plate.

NOTE: Any models supplied with Q or B contact material are RoHS compliant.

KM12 models  when ordered with 'Q' contact material.

SEAL

E EPOXY SEAL

AVAILABLE HARDWARE

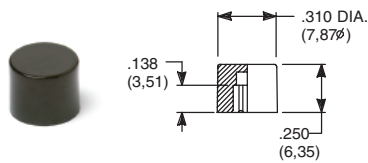

PART NO.
801801000 WHITE
801802000 BLACK
801803000 RED

Material: Nylon
Finish: Gloss

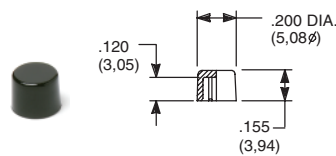

PART NO.
708901000 WHITE
708902000 BLACK
708903000 RED

Material: Nylon
Finish: Gloss

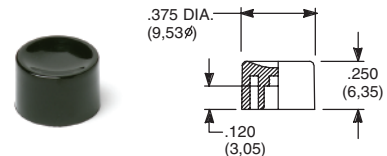

PART NO.
752701000 WHITE
752702000 BLACK
752703000 RED

Material: Nylon
Finish: Gloss

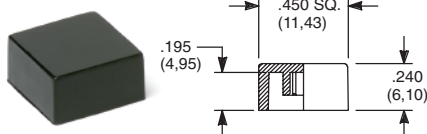

PART NO.
484601000 WHITE
484602000 BLACK
484603000 RED

Material: Nylon
Finish: Gloss

PART NO.
798201000 WHITE
798202263 BLACK
798203000 RED

Material: Nylon
Finish: Matte

NOTE: Other cap colors available, consult Customer Service Center.



E

Detect

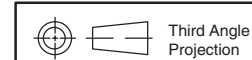

Dimensions are shown: mm
Specifications and dimensions subject to change

MPS Series Magnetic Proximity Sensors

Features/Benefits

- Long life—4M operations
- Sealed contacts
- Quality construction
- Quick and easy installation
- UL 61058 approved

Typical Applications

- Automotive sensors and indicators
- Industrial sensors
- Factory automation equipment
- Server / storage
- Security, alarms for windows

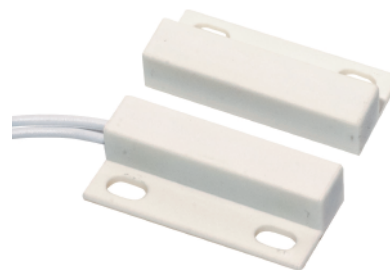

Specifications

CONTACT RATINGS: 3.0 W max. @ 30 V DC or 30 V AC max. @ 0.3 AMP max.; 1.0 msec. max. operate time (including bounce); 1.0 AMP max. carry current.

CONTACT RESISTANCE: 100 m Ω max. initial.

DIELECTRIC STRENGTH: 200 V DC min.

ELECTRICAL CIRCUIT: SPST NO (Contact Form A). Reed switch opens when magnet is removed from proximity. Contacts are held closed when magnet is within actuation range.

OPERATING TEMPERATURE: -40°F to 212°F (-40°C to 100°C).

OPERATING DISTANCE/ALIGNMENT: Operate (pull-in or make) points are nominal values with ± 10% tolerance. Release points are 110% to 150% of the operating points.

MECHANICAL & ELECTRICAL LIFE: 4 million operations.

PACKAGING: Bulk packaging, 10 switch and magnet pairs per package.

Materials

HOUSING/SPACER/COVER: ABS plastic (UL94V-0), white.

REED SWITCH: Rhodium coated reed contacts in hermetically sealed, nitrogen filled glass capsule. Closed when magnet is in close proximity. Used in closed loop circuits.

WIRE LEADS: UL 1061/ UL1007 / UL2468

All are 22 AWG wire: stranded, made of copper or aluminum; Length: 12 in. with ends stripped; Color: white.

POTTING (around wires): Epoxy.

MAGNETS: NdFeB

ADHESIVE MOUNTING: Foam-backed, pressure-sensitive adhesive with release liner.

NOTE: Specifications and materials listed above are for switches with standard options. For information on specific and custom switches, consult Customer Service Center.

How To Order

| PART NUMBER | SWITCH TYPE |
|-------------|--|
| MPS45WGW | Subminiature surface mount (adhesive or flange), side exit leads, 1" make gap. |

UL 61058



Detect

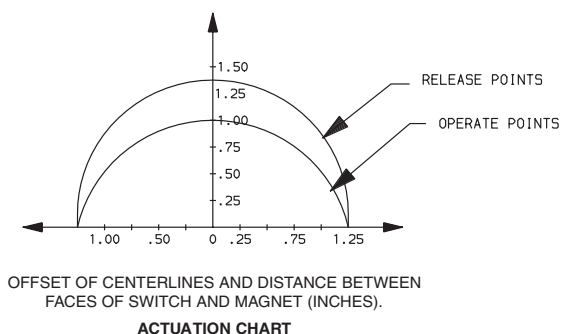

NOTE: UL 61058 Rating

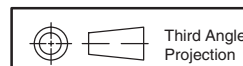
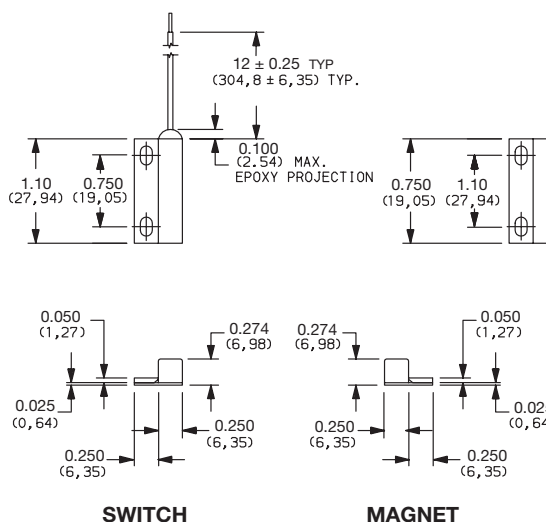

Dimensions are shown: inches (mm)
Specifications and dimensions subject to change



MPS Series Magnetic Proximity Sensors

Actuating Positions

When installing recessed and surface mount contacts, magnet position is very important. The switch and magnet must always be parallel or end to end, and never in a 'T' configuration.

Gap Distance

Gap distance is a combination of the horizontal and vertical plane separation of the switch and magnet. Example: if a recessed magnet is 1/4" off the centerline of the switch, the make gap is reduced by 1/4"

Correct Configuration

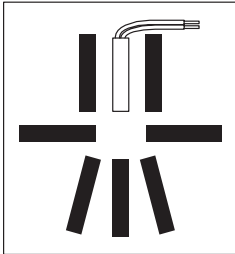

Incorrect Configuration

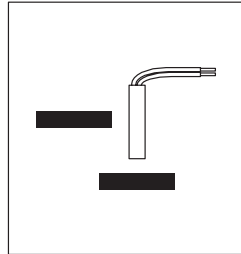

Center Alignment

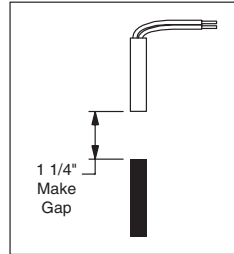

Off Center Alignment

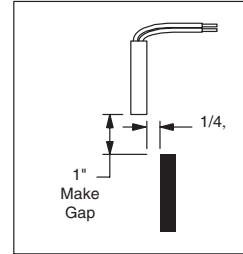

Detect

ZMA Series Subminiature Snap-acting Switches



Features/Benefits

- Reliable snap-acting mechanism
- Long electrical and mechanical life
- Compact size—Ideal when space is limited
- Various PCB terminals and actuators
- RoHS compatible & compliant

Typical Applications

- PCB detection switch
- Communication devices
- Testing equipment
- Security/Alarm systems
- Consumer electronics

UL61058-1



Specifications

CONTACT RATING: 3A @ 125 V AC 24 V DC
 1 A @125 / 250 V AC 24 V DC
 0.1A @ 125 V AC 60 V DC

ELECTRICAL LIFE: 300,000 cycles @ 0.1A / 10,000 cycles @ 3A.
 MECHANICAL LIFE: 1,000,000 cycles.
 INSULATION RESISTANCE: 100 M ohm min.
 DIELECTRIC STRENGTH: 500 Vrms.
 OPERATING TEMPERATURE: -40°C to 85°C
 OPERATING FORCE: 80 or 150 grams.

* Low Level=conditions where no arcing occurs during switching, i.e., 0.4 VA max.
 @ 20 V AC or DC max.

Materials

CASE/COVER: PBT
 ACTUATOR: Button nylon 6/6
 MOVABLE CONTACTS: Silver alloy or gold plated
 STATIONARY CONTACTS: Silver alloy or gold plated
 TERMINALS: Brass, silver plated.

NOTE: Specifications and materials listed above are for switches with standard options. For information on specific and custom switches, consult Customer Service Center.

Build-A-Switch

To order, simply select desired option from each category and place in the appropriate box. Available options are shown and described on pages J-33 through J-35. For additional options not shown in catalog, consult Customer Service Center.

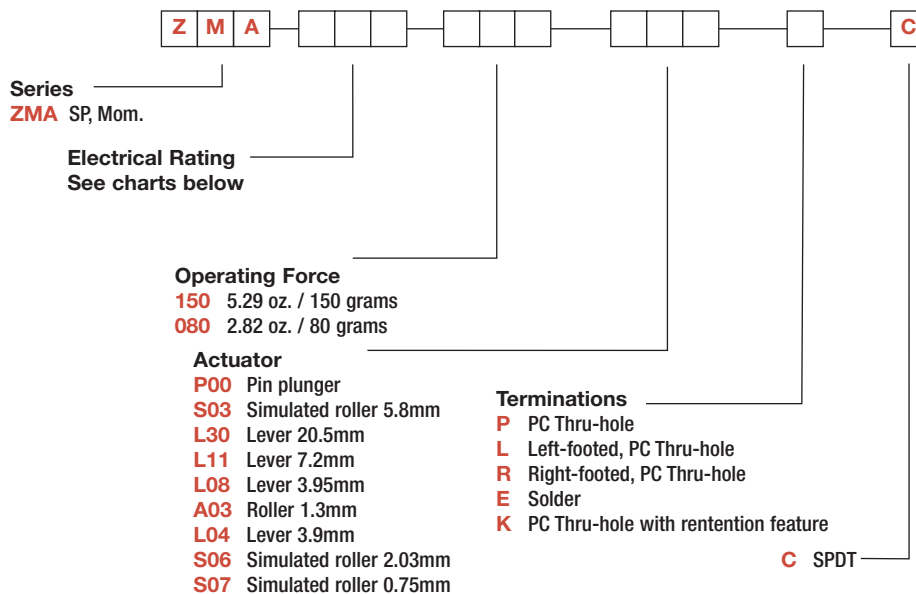

Detect
E

Silver Contacts

| Option Code | UL 1054 | UL 61058-1 | 4 | 15 |
|-------------|-------------------------------|-----------------------------------|---------------|-----------------------------------|
| 00A | 0.1A 60 V DC 0.1A 125 V AC | 0.1A 60 V DC 0.1A 125 V AC | 0.1A 125 V AC | |
| 03A | 3 A 125 V AC | 3 A 125 V AC 3 A 24 V DC | 3A 125 V AC | |
| 01A | | 1 A 24 V DC 1 A 125 / 250 V AC | | 1 A 24 V DC 1 A 125 / 250 V AC |

Gold Plated Contacts

| Option Code | UL 1054 | UL 61058-1 | 4 | 15 |
|-------------|-------------------------------|-----------------------------------|---------------|-----------------------------------|
| G00 | 0.1A 60 V DC 0.1A 125 V AC | 0.1A 60 V DC 0.1A 125 V AC | 0.1A 125 V AC | |
| G03 | 3 A 125 V AC | 3 A 125 V AC 3 A 24 V DC | 3A 125 V AC | |
| G01 | | 1 A 24 V DC 1 A 125 / 250 V AC | | 1 A 24 V DC 1 A 125 / 250 V AC |



Dimensions are shown: mm
 Specifications and dimensions subject to change

ZMA Series Subminiature Snap-acting Switches

SERIES

ZMA SUBMINIATURE SNAP-ACTING SWITCHES – SP MOMENTARY

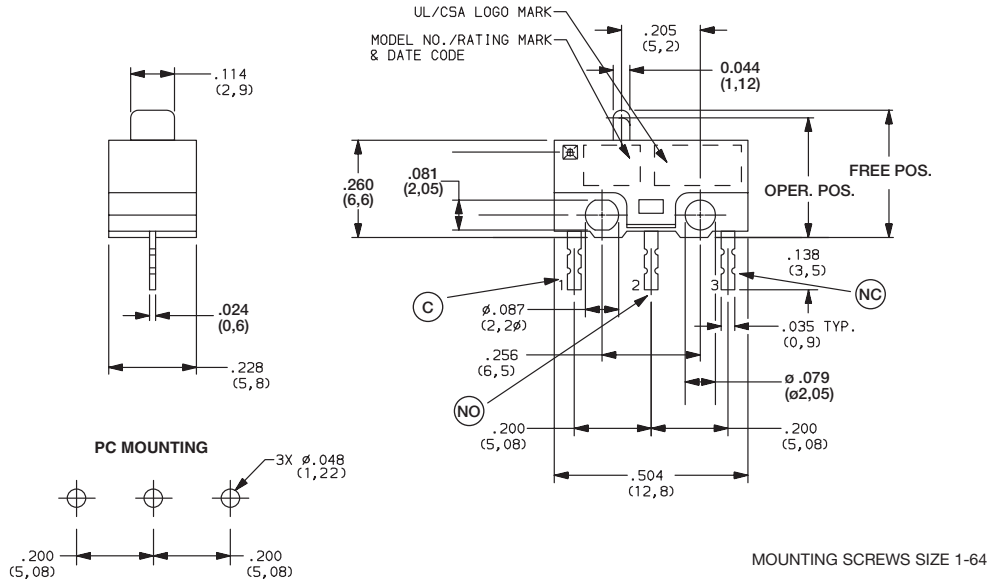

ZMA03A150L04PC
SPDT

ELECTRICAL RATING

Silver Contacts

| Option Code | UL c US 1054 | UL c US 61058-1 | | |
|-------------|-------------------------------|-----------------------------------|---------------|-----------------------------------|
| 00A | 0.1A 60 V DC 0.1A 125 V AC | 0.1A 60 V DC 0.1A 125 V AC | 0.1A 125 V AC | |
| 03A | 3 A 125 V AC | 3 A 125 V AC 3 A 24 V DC | 3A 125 V AC | |
| 01A | | 1 A 24 V DC 1 A 125 / 250 V AC | | 1 A 24 V DC 1 A 125 / 250 V AC |

Gold Plated Contacts

| Option Code | UL c US 1054 | UL c US 61058-1 | | |
|-------------|-------------------------------|-----------------------------------|---------------|-----------------------------------|
| G00 | 0.1A 60 V DC 0.1A 125 V AC | 0.1A 60 V DC 0.1A 125 V AC | 0.1A 125 V AC | |
| G03 | 3 A 125 V AC | 3 A 125 V AC 3 A 24 V DC | 3A 125 V AC | |
| G01 | | 1 A 24 V DC 1 A 125 / 250 V AC | | 1 A 24 V DC 1 A 125 / 250 V AC |

* Note: See Technical Data in section N of this catalog for RoHS compliant and compatible definition and specifications.

All models US with all options.

Consult Customer Service center for availability and delivery of nonstandard ratings.

OPERATING FORCE

| OPTION CODE | BASIC SWITCH OPERATING FORCE (OZ./GRAMS) |
|-------------|--|
| 150 | 5.29 150 |
| 080 | 2.82 80 |



Third Angle
Projection

Dimensions are shown: mm
Specifications and dimensions subject to change



E

Detect

ZMA Series Subminiature Snap-acting Switches

ACTUATOR

P00 PIN PLUNGER

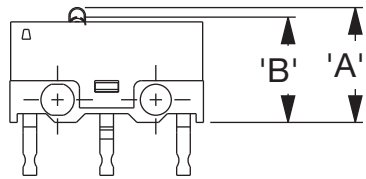

L08 LEVER
3.95MM

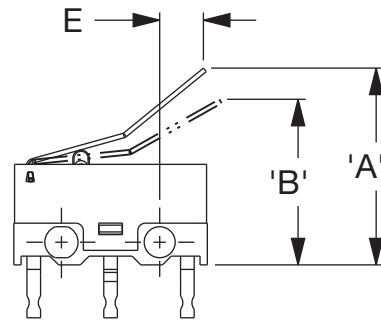

S03 SIMULATED ROLLER
5.8MM

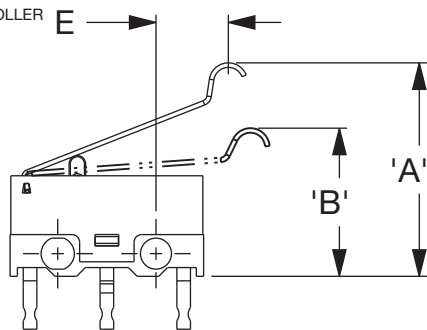

A03 ROLLER
1.3MM

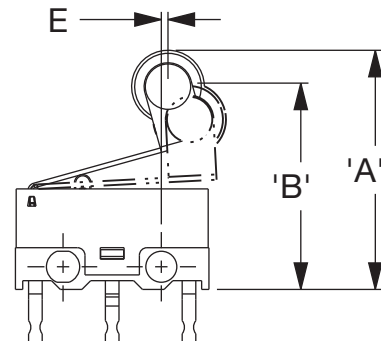

L30 LEVER
20.5MM

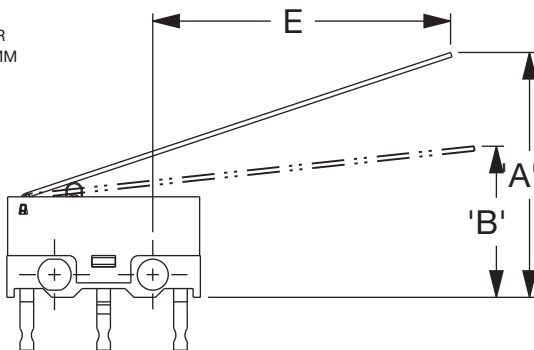

L04 LEVER
3.49MM

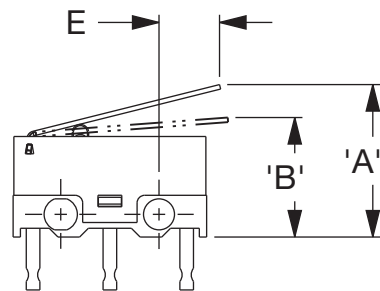

L11 LEVER
7.2MM

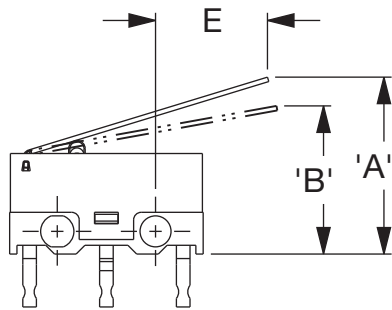

S06 SIMULATED ROLLER
2.03MM

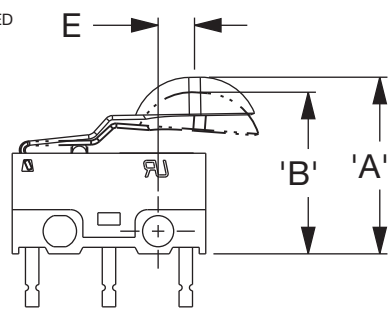

S07 SIMULATED ROLLER
0.75MM

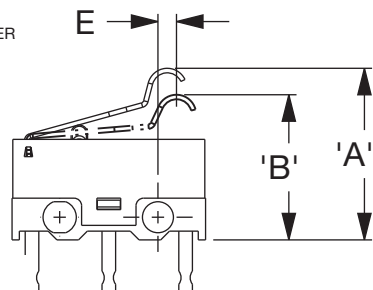

Detect

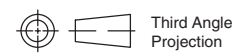

Third Angle
Projection

Dimensions are shown: mm
Specifications and dimensions subject to change

ZMA Series Subminiature Snap-acting Switches

SWITCH CHARACTERISTICS

| CODE | OPER. FORCE MAX. (GRAMS) | | REL. FORCE MIN. (GRAMS) | | 'A' FP MAX. (MM) | 'B' OP MAX. (MM) | 'C' PT MAX. (MM) | 'D' OT MIN. (MM) | 'E' MIN. (MM) |
|--------------|-----------------------------|-----|----------------------------|----|------------------------|------------------------|------------------------|------------------------|---------------------|
| P00 | 80 | 150 | 21 | 35 | 7.35 | 6.9 ±0.3 | 0.62 | 0.2 | |
| S03 | 25 | 43 | 5 | 7 | 14.2 | 9.8 ±0.9 | 3.5 | 0.7 | 5.41 |
| L30 (80gf) | 13 | 21 | 2 | 3 | 16.8 | 9.5 ±1.9 | 6.9 | 0.55 | 20.15 |
| L30 (150 gf) | 13 | 21 | 2 | 3 | 16.8 | 9.75 ±1.9 | 6.9 | 0.55 | 20.15 |
| L11 | 25 | 39 | 4 | 6 | 11.7 | 8.68 ±1 | 4.4 | 0.6 | 7.33 |
| L08 | 27 | 48 | 3 | 8 | 13.5 | 10.75 ±0.8 | 3.5 | 0.3 | 3.82 |
| A03 | 34 | 65 | 6 | 10 | 16.55 | 13.65 ±1 | 3.9 | 0.5 | 0.56 |
| L04 | 30 | 50 | 5 | 8 | 10.1 | 7.9 ±0.7 | 3.0 | 0.5 | 3.49 |
| S06 | 33 | 49 | 5 | 11 | 12.43 | 10.7 ±0.8 | 1.43 | 1.25 | 1.97 |
| S07 | 40 | 65 | 2 | 5 | 13.0 | 9.7 ±1 | 4.3 | 0.5 | 0.49 |

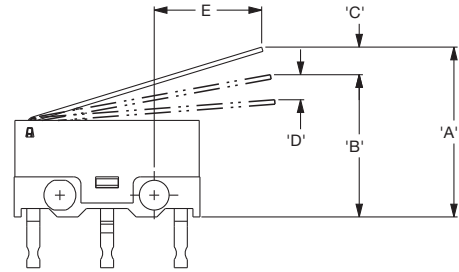

TERMINATIONS

P PC THRU-HOLE

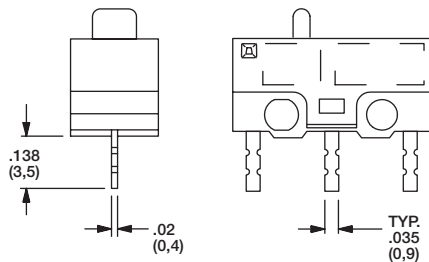

L LEFT FOOTED, PC THRU-HOLE

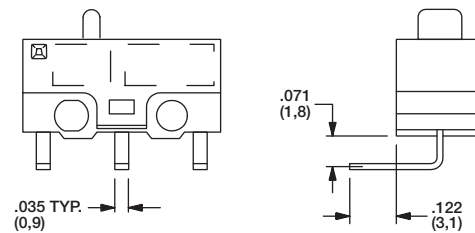

R RIGHT FOOTED, PC THRU-HOLE

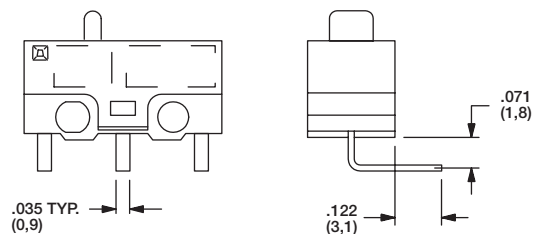

E SOLDER

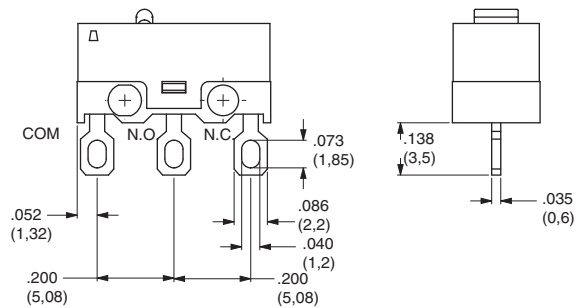

K PC THRU-HOLE WITH RETENTION FEATURE

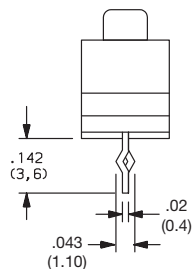

Detect

Detect

KSU Series Micro Mini Surface Mount Detect Switches



Features/Benefits

- New multi contact construction
- Metal actuator
- Low actuating force
- RoHS compliant and compatible

Typical Applications

- Mobile phones and other handheld devices
- Portable medical devices
- Audio devices
- Alarm devices
- Payment terminals
- Smart meters

Specifications

FUNCTION: Momentary action.
CONTACT TYPE: SPST Normally open.
TERMINALS: Gullwing type for SMT.

Mechanical

SWITCHING FORCE: $0,7 \pm 0,5$ N
TRAVEL TO MAKE: 0,65 mm - 0,45/+0,25 mm
MECHANICAL TRAVEL: $1,5 \pm 0,2$ mm
OPERATING LIFE: 100,000 cycles

Packaging

Switches are delivered on continuous tape, in reels of 1,000 pieces

Electrical

| | GOLD | SILVER |
|------------------------|-------------------------|--------|
| MAXIMUM POWER: | 0.2 VA | 0.1 VA |
| MAXIMUM VOLTAGE: | 32 VDC | 32 VDC |
| MINIMUM VOLTAGE: | 20 mV | 20 mV |
| MAXIMUM CURRENT: | 10 mA | 50 mA |
| MINIMUM CURRENT: | 0.01 mA | 1 mA |
| CONTACT RESISTANCE: | ≤100 mΩ | |
| INSULATION RESISTANCE: | (100 VDC) $10^9 \Omega$ | |
| DIELECTRIC STRENGTH: | ≥ 250 Vrms | |
| BOUNCE TIME: | ≤ 3 ms | |

Environmental

OPERATING TEMPERATURE: -40°C to +125°C -40°C to +85°C
STORAGE TEMPERATURE: -55°C to + 125°C -40°C to +85°C

Process

SOLDERING: Compatible with lead free reflow process

NOTE: Specifications listed above are for switches with standard options.
For information on specific and custom switches, consult Customer Service Center.

How To Order

Our easy build-a-switch concept allows you to mix and match options to create the switch you need. To order, select desired option from each category and place it in the appropriate box.

For any part number different from those listed above, please consult your local representative.

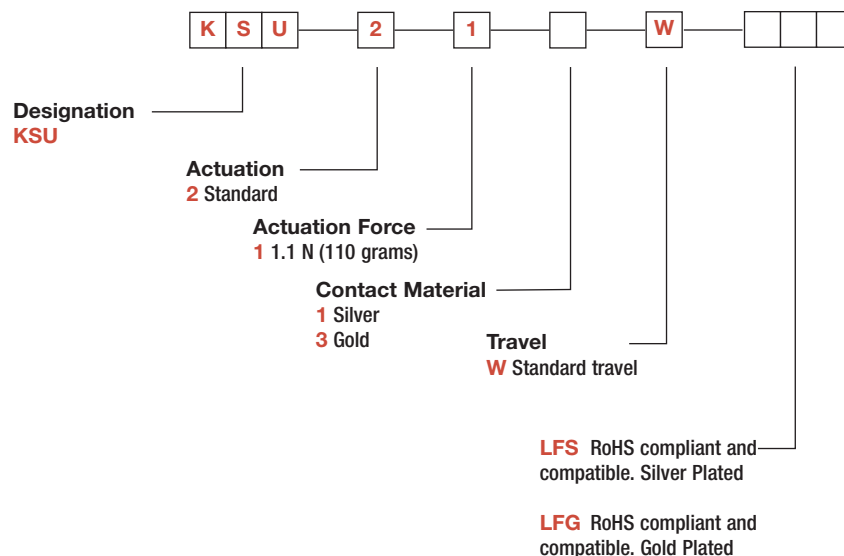

Detect

KSU Series Micro Mini Surface Mount Detect Switches

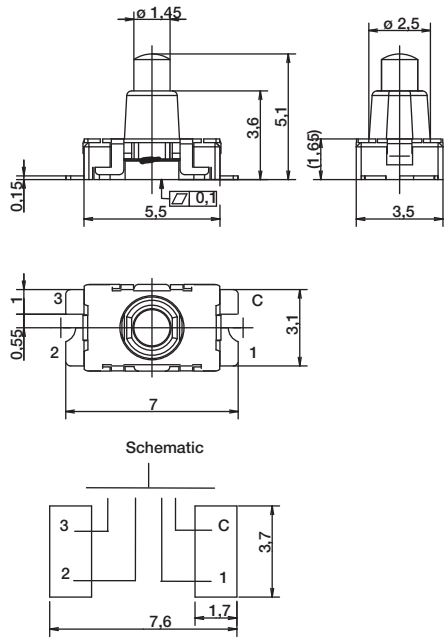

TAPE & REEL

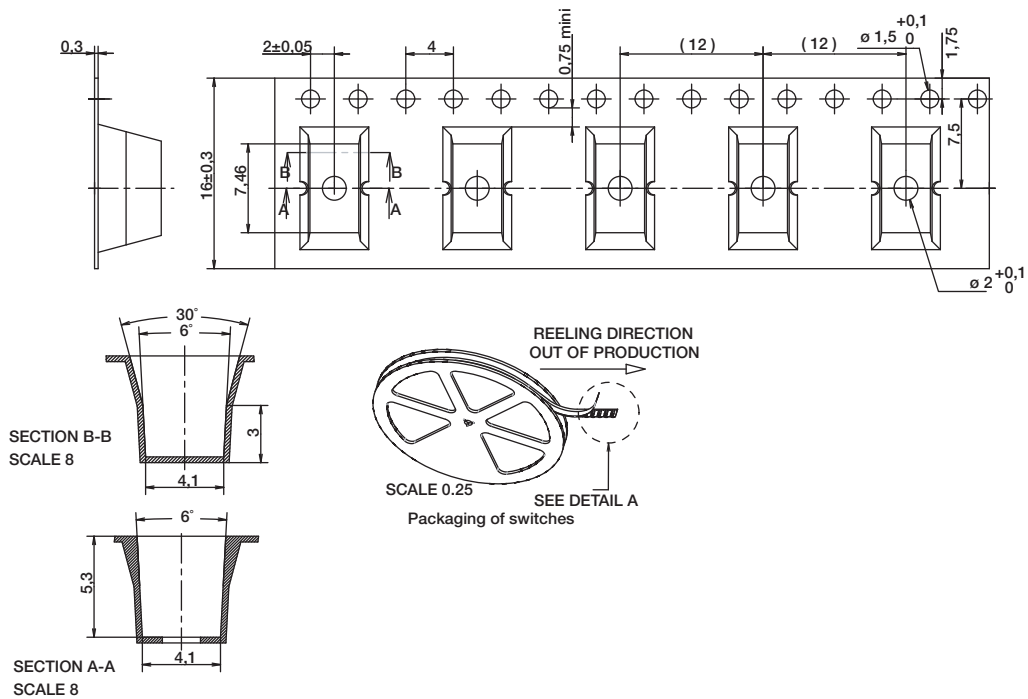

Detect



Dimensions are shown: mm
Specifications and dimensions subject to change

www.ck-components.com

KSR2D/M Series Subminiature Detect Switch for SMT



Features/Benefits

- Gold contacts
- G terminations
- Soft actuator
- RoHS compliant and compatible

Typical Applications

- Automotive
- Industrial electronics
- Medical equipment
- Detector switch applications

Specification

FUNCTION: momentary action
CONTACT ARRANGEMENT: N.O.
TERMINALS: Gullwing type for SMT

| Type | Operating force Newtons | Operating life (operations) | Travel (mm) |
|--------------|----------------------------|--------------------------------|-------------|
| KSR2D3MG LFG | 1,5 ± 0,5N | 100,000 | 0,3 ± 0,15 |
| KSR2M3G LFG | 0,8 ± 0,4N | 100,000 | 0,19 ± 0,11 |

Packaging

Switches are delivered on continuous tape, in reels of 2,500 pieces.
For information on specific and custom switches, consult Customer Service Center.

Electrical

| | |
|-----------------------------------|-------------------|
| MAXIMUM POWER: | Gold 0.2 VA |
| MAXIMUM VOLTAGE: | 32 VDC |
| MINIMUM VOLTAGE: | 20 mV |
| MAXIMUM CURRENT DC: | 10 mA |
| MINIMUM CURRENT DC: | 1 mA |
| CONTACT RESISTANCE: | 100 mΩ |
| INSULATION RESISTANCE (100 V): | 10 ⁹ Ω |
| BOUNCE TIME: | 1 ms |

Environmental

| | |
|------------------------|------------------------|
| OPERATING TEMPERATURE: | Gold -40°C to 125°C |
| STORAGE TEMPERATURE: | -55°C to 125°C |

Process

SOLDERING: Compatible with lead free reflow soldering process

How To Order

Our easy build-a-switch concept allows you to mix and match options to create the switch you need. To order, select desired option from each category and place it in the appropriate box.

For any part number different from those listed above, please consult your local representative.

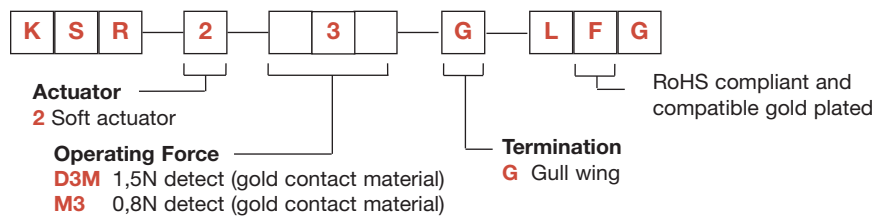

Detect

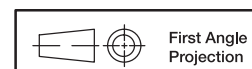

Dimensions are shown: mm
Specifications and dimensions subject to change

KSR2D/M Series Subminiature Detect Switch for SMT

KSR2D/M

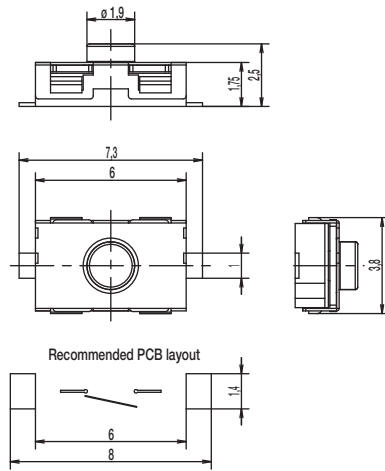

TAPE & REEL

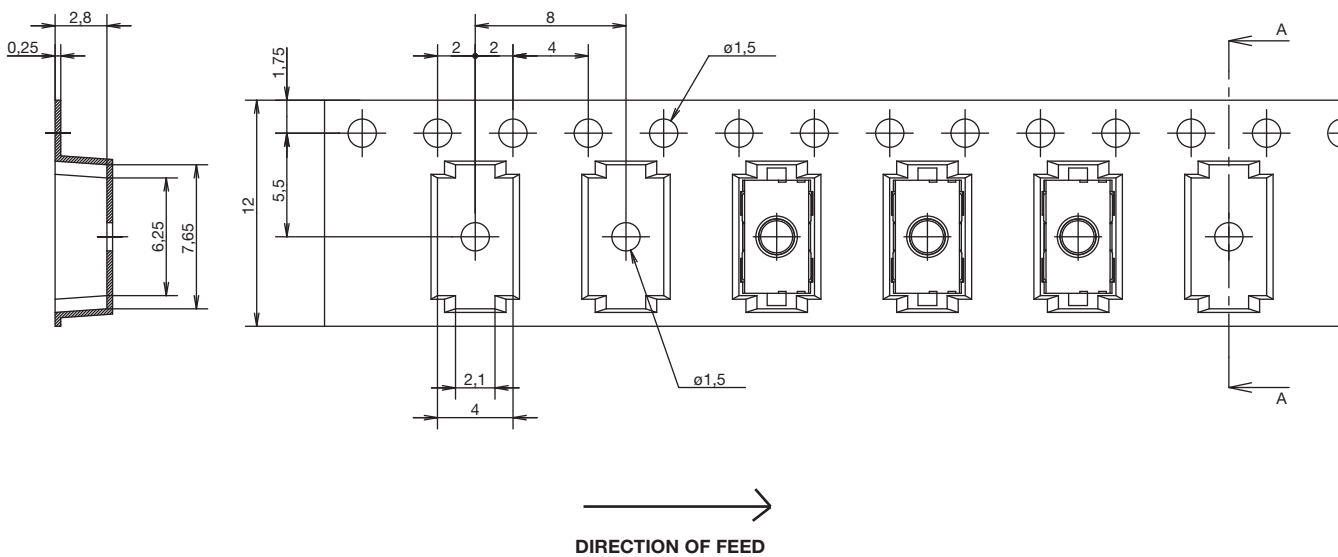

First Angle
Projection

Dimensions are shown: mm
Specifications and dimensions subject to change

KSM Series Side Actuated Detect Switches

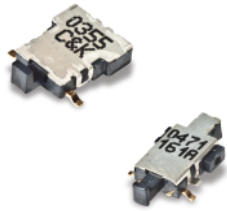

Features/Benefits

- Low profile – 1,5 mm
- Momentary, normally closed contact
- Gold contacts
- RoHS compliant and compatible

Typical Applications

- Automotive
- Position sensing switch
- Edge card reset switch
- Smart card presence switch detector
- DSL and fiber optic networks

Specifications

FUNCTION: Momentary action
CONTACT TYPE: SPST Normally closed

Mechanical

| | | |
|------------------|--------------|----------------|
| TRAVEL TO BREAK: | KSM1131D LFG | 0,35 ± 0,15 mm |
| | KSM6161 LFG | 0,5 ± 0,20 mm |
| TOTAL TRAVEL: | KSM1131D LFG | 1,25 ± 0,2 mm |
| | KSM6161 LFG | 1,92 ± 0,2 mm |

SWITCHING FORCE:

| | |
|--------------|----------------------------------|
| KSM1131D LFG | 0,15N ≤ F _{ce} ≤ 0,90 N |
| KSM6161 LFG | 0,50N ≤ F _{ce} ≤ 0,90 N |

| | | |
|-----------------|--------------|----------------|
| OPERATING LIFE: | KSM1131D LFG | 50,000 cycles |
| | KSM6161 LFG | 200,000 cycles |

Packaging

Switches are delivered on continuous tape, in reels of 2,000 pieces (KSM1131D LFG) and 1250 pieces (KSM6161 LFG)

Electrical

| | KSM1131D LFG | KSM6161 LFG |
|------------------------|---------------------|-------------------|
| MAXIMUM POWER: | 0.2 VA | 1.0 VA |
| MAXIMUM VOLTAGE: | 24 VDC | 32 VDC |
| MINIMUM VOLTAGE: | 20 mV | 20 mV |
| MAXIMUM CURRENT DC: | 50 mA | 50 mA |
| MINIMUM CURRENT DC: | 1 mA | |
| CONTACT RESISTANCE: | ≤ 300 mΩ | ≤ 900 mΩ |
| INSULATION RESISTANCE: | ≥ 10 ⁹ Ω | ≥ 10 ⁹ |
| DIELECTRIC STRENGTH: | ≥ 250 Vrms | ≥ 250 Vrms |
| BOUNCE TIME: | ≤ 10 ms | ≤ 1,25 ms |

Environmental

| | |
|------------------------|----------------|
| OPERATING TEMPERATURE: | -40°C to +85°C |
| STORAGE TEMPERATURE: | -55°C to +85°C |

Process

SOLDERING: Compatible with lead free reflow process

NOTE: Specifications listed above are for switches with standard options. For information on specific and custom switches, consult Customer Service Center.

How To Order

Our easy build-a-switch concept allows you to mix and match options to create the switch you need. To order, select desired option from each category and place it in the appropriate box.

For any part number different from those listed above, please consult your local representative.



Detect
E

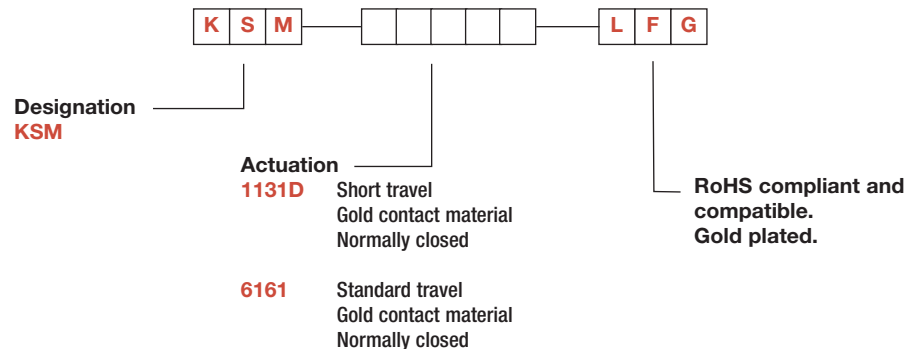

Dimensions are shown: mm
Specifications and dimensions subject to change



KSM Series Side Actuated Detect Switches

KSM1131D LFG

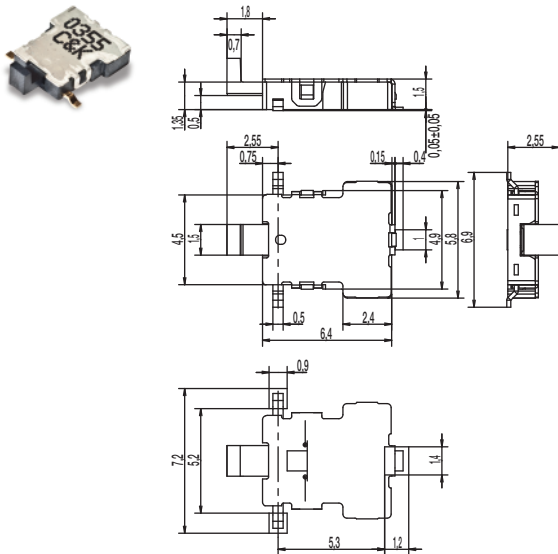

KSM6161 LFG

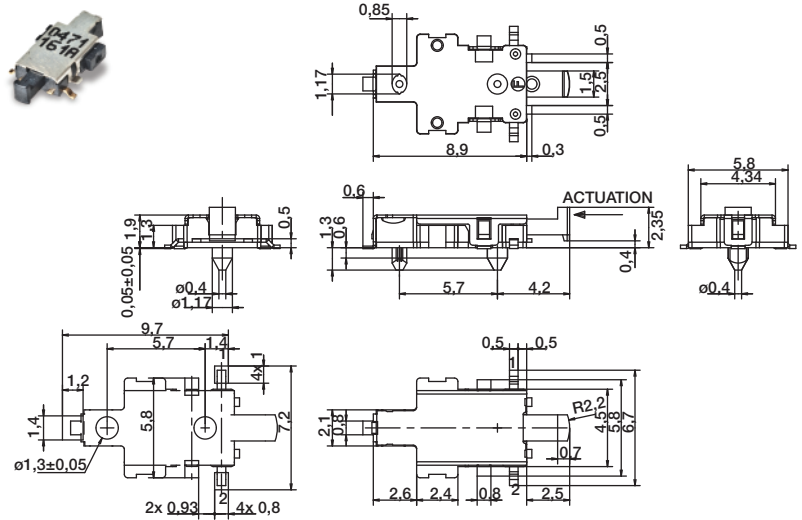

KSM1131D LFG

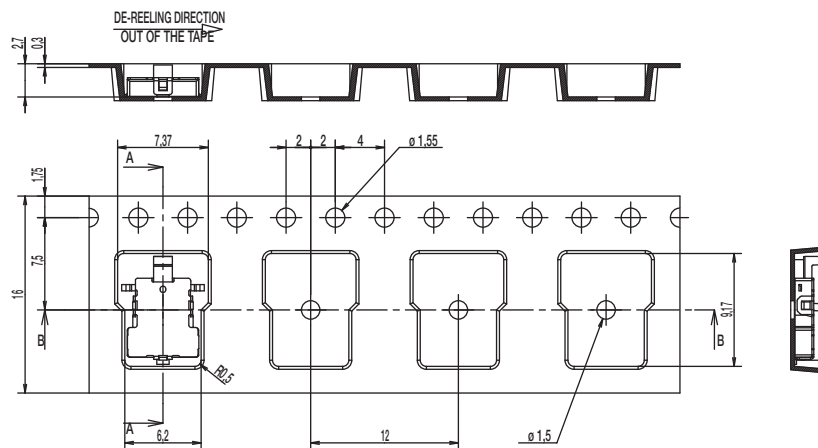

KSM6161 LFG

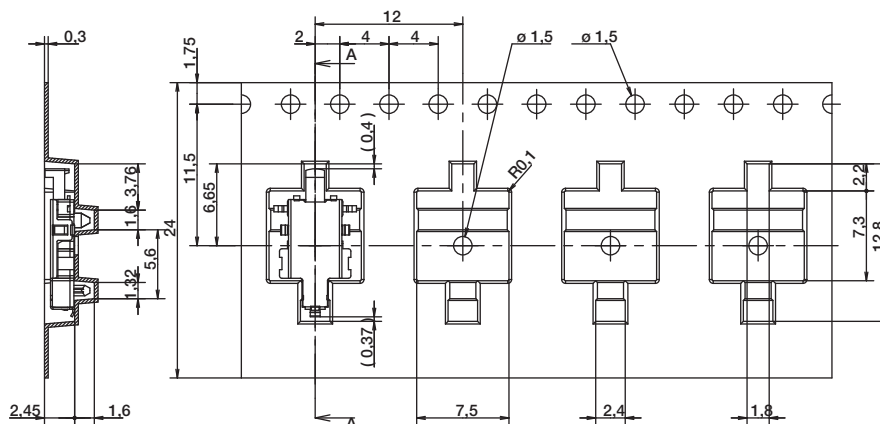

Detect



First Angle Projection
Specifications and dimensions subject to change



KSC4D Series Sealed Detect Switch for SMT

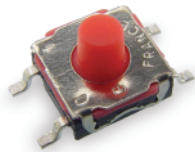

Features/Benefits

- Soft actuator
- J or G terminations
- Tape & reel
- IP 67
- RoHS compliant and compatible

Typical Applications

- Automotive
- Cellular phones
- Industrial electronics
- Computer infrastructure and IT

Specification

FUNCTION: momentary action compatible with permanent actuation
 CONTACT ARRANGEMENT: 1 make contact = SPST, N.O.
 TERMINALS: J bend & Gullwing type for SMT
 Compatible with permanent actuation

Mechanical

| Type | Operating force FA Newtons | Operating life (operations) | Travel (mm) |
|-------------|-------------------------------|-----------------------------------|----------------|
| KSC4D1J50SH | 1,0 - 3,0 | 500,000 | 0,6 ± 0,25 |
| KSC4D2J50SH | 1,0 - 3,0 | 2,000,000 | |
| KSC4D350SH | 1,0 - 3,0 | 500,000 | |

Electrical

| | Silver | Gold |
|--------------------------------------|---------------------|--------|
| MAXIMUM POWER: | 1 VA | 0.2 VA |
| MAXIMUM VOLTAGE: | 32 VDC | 32 VDC |
| MINIMUM VOLTAGE: | 20 mV | 20 mV |
| MAXIMUM CURRENT: | 50 mA | 10 mA |
| MINIMUM CURRENT: | 1 mA | 0.1 mA |
| DIELECTRIC STRENGTH (50 Hz, 1 min.): | ≥ 250 V | |
| CONTACT RESISTANCE: | ≤ 100 mΩ | |
| INSULATION RESISTANCE (100 V): | ≥ 10 ⁹ Ω | |
| BOUNCE TIME: | ≤ 1 ms | |

Electrical

| | Silver | Gold |
|------------------------|---------------|----------------|
| OPERATING TEMPERATURE: | -40°C to 85°C | -40°C to 125°C |
| STORAGE TEMPERATURE: | -55°C to 85°C | -55°C to 125°C |

Process

SOLDERING:

- Infrared Reflow according to free soldering process with IEC 61760-1.

Packaging

Reels of 1,000 pieces. Dimensions of reels according to EIA RS481 or IEC 60286-3. External diameter 330 mm ± 2 mm.

NOTE: Part numbers listed above do not represent all possible configurations. For information on specific and custom switches, consult Customer Service Center.

This data sheet does not provide enough information for applications which require a certain level of quality or safety such as automotive, medical systems, safety equipment. Please contact your sales representative to get contractual specification package.

How To Order

Our easy build-a-switch concept allows you to mix and match options to create the switch you need. To order, select desired option from each category and place it in the appropriate box.

However, please note that all the combinations of these options are not feasible.

For any part number different from those listed above, please consult your local representative.



Detect
E

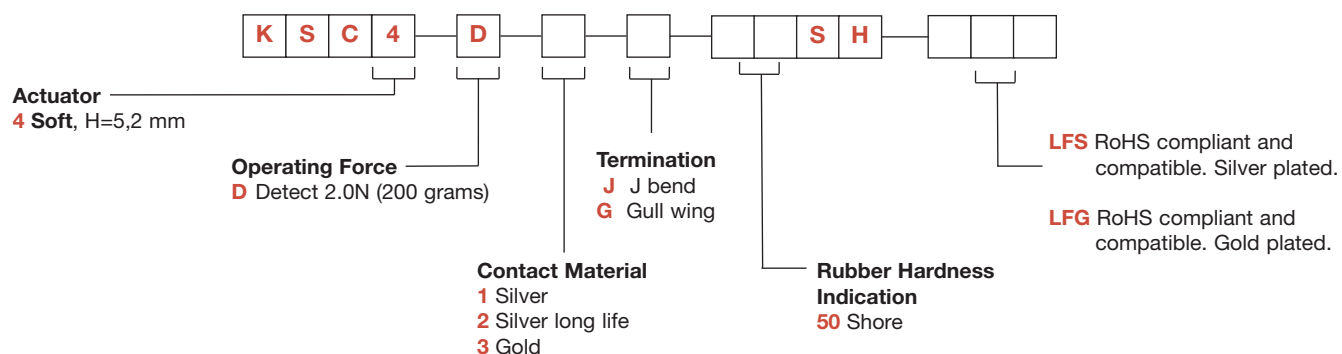

KSC4D Series Sealed Detect Switch for SMT

KSC4D1J SOFT, 5,2 mm high

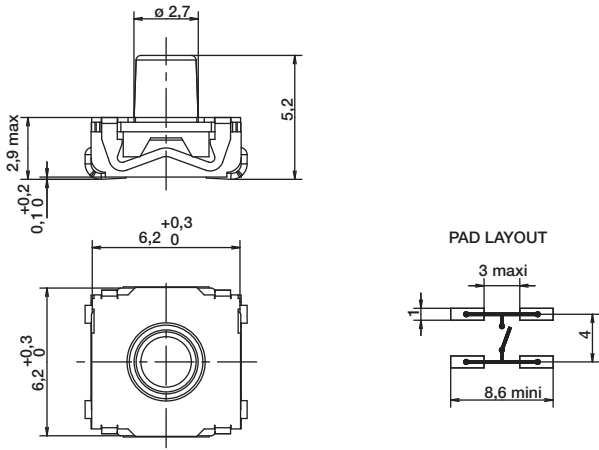

KSC4D1G SOFT, 5,2 mm high

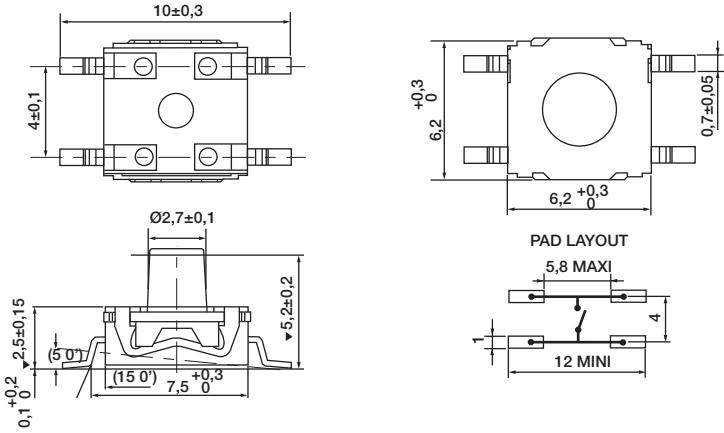

TAPE AND REEL

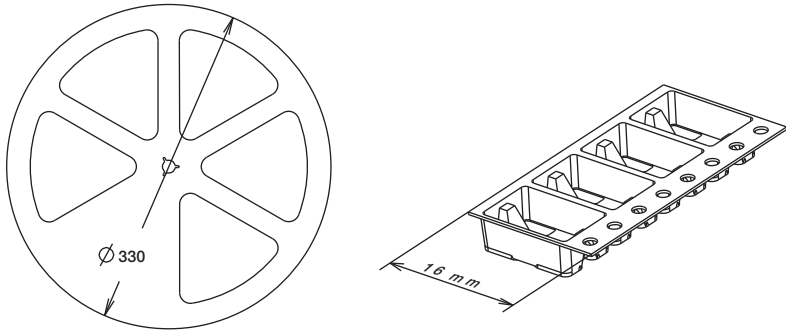

First Angle
Projection

Dimensions are shown: mm
Specifications and dimensions subject to change

www.ck-components.com



Detect

KSJ Detect Series Spherical Actuator Detect Switches



Features/Benefits

- Straight or vertical detect
- Top or side actuation
- Spherical actuator allows actuation +/- 30°
- High travel
- Adapted for cam actuation
- Sealing IP60

Typical Applications

- Automotive
- Industrial electronics
- Computer infrastructure and IT

Specification

FUNCTION: momentary action
 CONTACT ARRANGEMENT: 1 make contact = SPST, N.O.
 TERMINALS: PC pins
 Compatible with permanent actuation

Electrical

| | Silver | Gold |
|------------------------|---------------|----------------|
| OPERATING TEMPERATURE: | -40°C to 85°C | -40°C to 125°C |
| STORAGE TEMPERATURE: | -40°C to 85°C | -55°C to 125°C |

Mechanical

| Type | Operating force FA Newtons (grams) | Operating life (operations) | Travel |
|-----------------|--|--------------------------------|-------------|
| KSJ0VD1860SHLFT | 6,0 (600) | 100,000 | 0,50 ± 0,25 |
| KSJ0MD1860SHLFT | 6,0 (600) | 100,000 | 0,50 ± 0,25 |

Process

Wave soldering, compatible with lead free soldering.

Packaging

In boxes of 250 pieces

Electrical

| | Silver | Gold |
|--------------------------------------|------------------------|--------|
| MAXIMUM POWER: | 1 VA | 0.2 VA |
| MINIMUM VOLTAGE: | 20 mV | 20 mV |
| MAXIMUM VOLTAGE: | 32 VDC | 32 VDC |
| MINIMUM CURRENT: | 1 mA | 1 mA |
| MAXIMUM CURRENT: | 50 mA | 10 mA |
| DIELECTRIC STRENGTH (50 Hz, 1 min.): | ≥ 250 V | |
| CONTACT RESISTANCE: | ≤ 100 m ohms | |
| INSULATION RESISTANCE (100 V): | ≥ 10 ⁹ ohms | |
| BOUNCE TIME: | ≤ 1 ms | |

How To Order

Our easy build-a-switch concept allows you to mix and match options to create the switch you need. To order, select desired option from each category and place it in the appropriate box.

However, please note that all the combinations of these options are not feasible.
 For any part number different from those listed above, please consult your local representative.

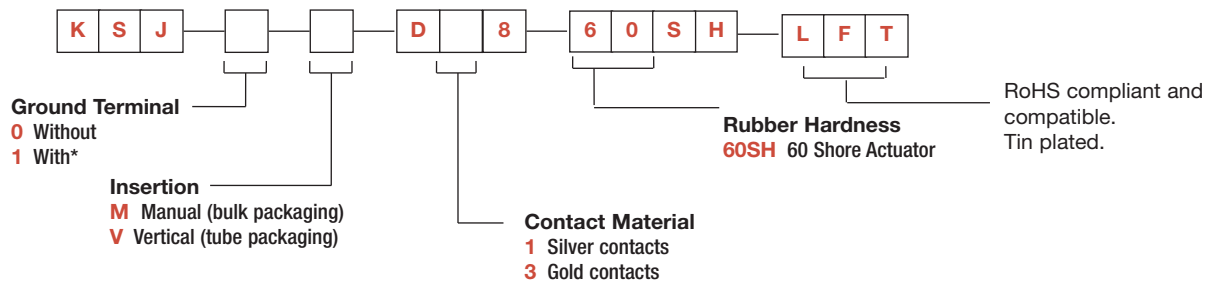

*Note: "1" ground terminal option not available with "V" version.
 The bracket for the "V" version plays this role.

KSJ Detect Series Spherical Actuator Detect Switches

KSJ

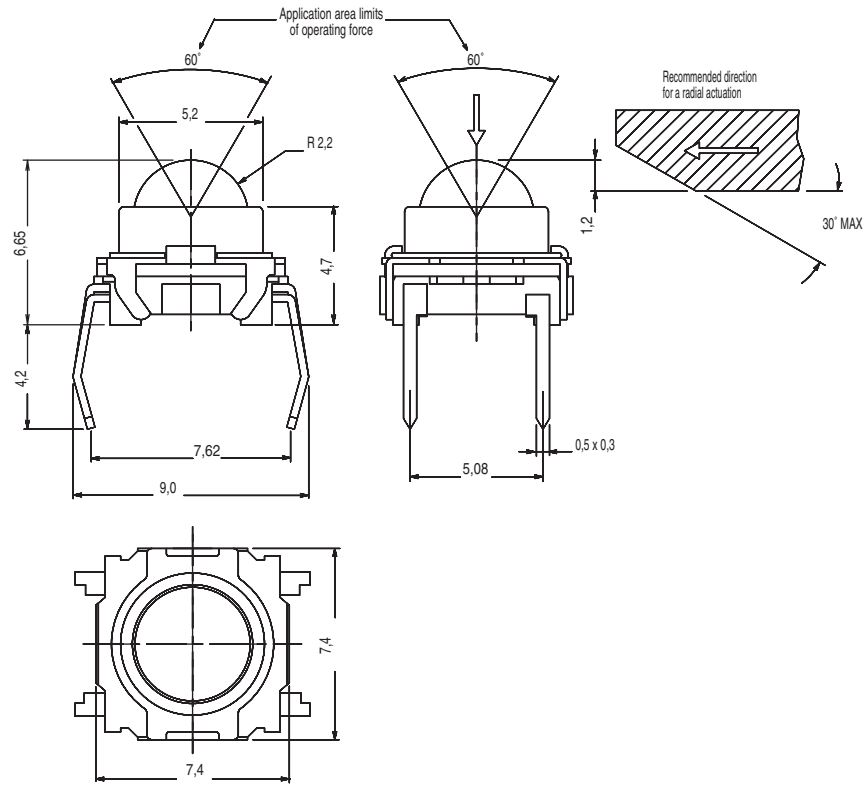

INSERTION

M MANUAL

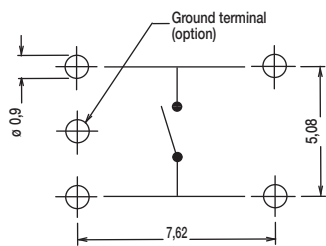
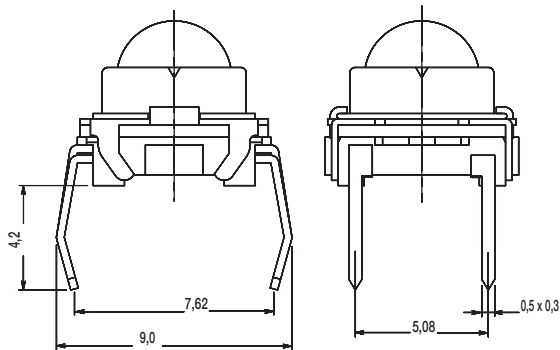

V VERTICAL

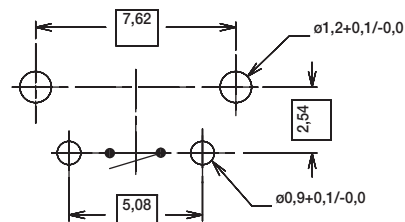
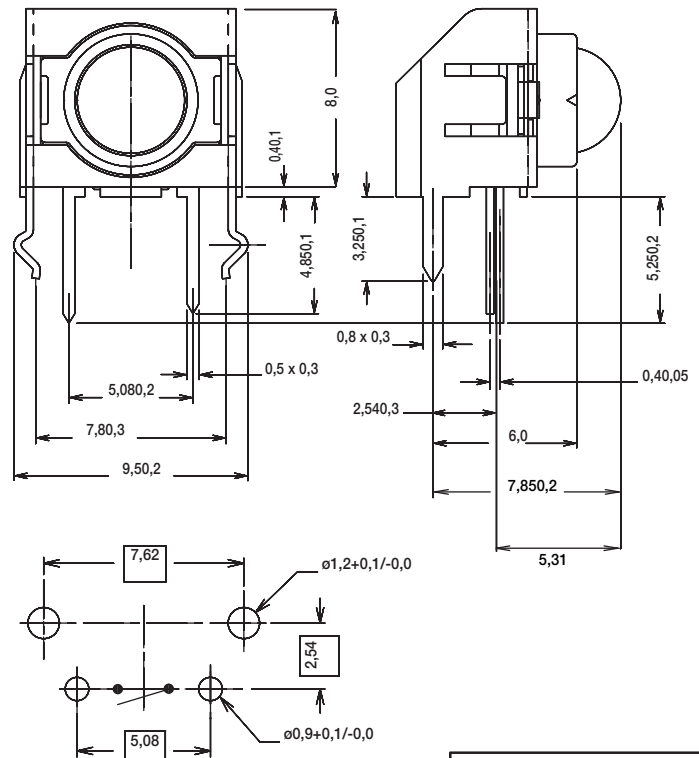

First Angle
Projection

Dimensions are shown: mm
Specifications and dimensions subject to change

C&K



Detect

RB Series Rolling Ball Sensor Switch

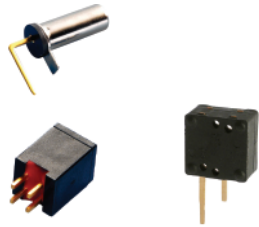

Features/Benefits

- Different angle options to trigger
- Ultra miniature design
- Patent awarded

Typical Applications

- Household goods
- Electronic toys
- Consumer electronics including irons, portable heaters, games, toys
- Safety and security controls

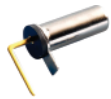

| PART NUMBER | PACKAGING |
|-----------------|--------------|
| RB-231X2 | 1,000 pieces |

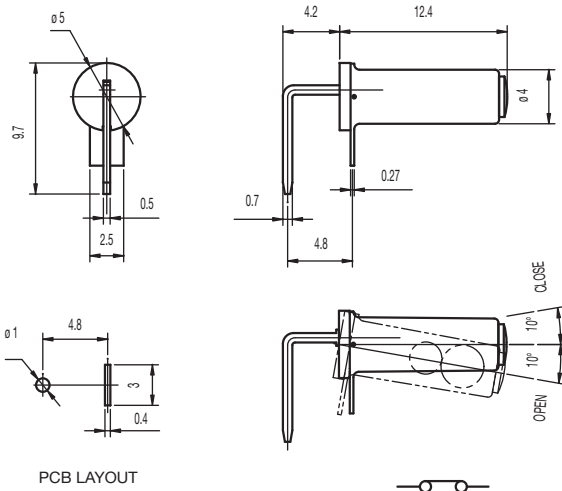

Specifications

CONTACT ARRANGEMENT: SPST
 SENSOR ANGLE: 0° to -10° scope inside, terminal to disconnection electric current
 MINIMUM VOLTAGE: 1 VDC 10mA (resistive load)
 MAXIMUM VOLTAGE: 5 VDC 1mA (resistive load)
 OPERATING LIFE: 100,000 cycles
 INSULATION RESISTANCE: 1000 M Ω min. @ 100 VDC
 DIELECTRIC STRENGTH: 500 V AC (50-60 Hz)
 OPERATING TEMPERATURE: -20°C to +70°C

Materials

FRAME: Copper alloy, nickel plated
 COVER: PA 46 (UL94V-0).
 MOVABLE CONTACT: Copper alloy, nickel plated
 TERMINALS: Copper alloy, gold plated
 BRASS BALL: Brass, gold plated



| PART NUMBER | PACKAGING |
|--------------------|------------|
| RB-220-07 R | 500 pieces |

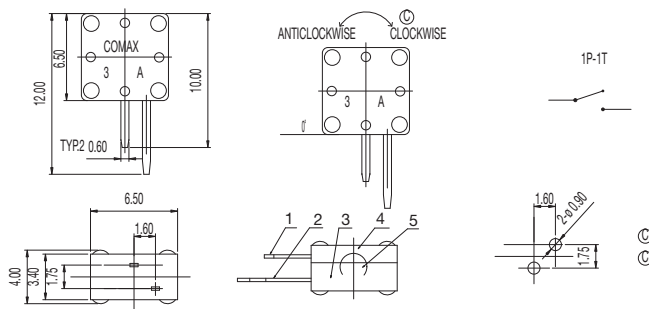
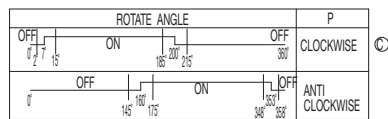

Specifications

CONTACT ARRANGEMENT: SPST
 SENSOR ANGLE: 15° to 90° scope inside, terminal to disconnection electric current
 MINIMUM VOLTAGE: 1 VDC 10mA (resistive load)
 MAXIMUM VOLTAGE: 5 VDC 1mA (resistive load)
 OPERATING LIFE: 20,000 cycles (without load);
 100,000 cycles with load
 INSULATION RESISTANCE: 10 M Ω min. @ 100 VDC
 DIELECTRIC STRENGTH: 100 V AC (50-60Hz)
 OPERATING TEMPERATURE: -10°C to +50°C

Materials

HOUSING: PA
 COVER: PA
 BALL: Gold plated



Detect



Dimensions are shown: mm
 Specifications and dimensions subject to change

RB Series Rolling Ball Sensor Switch

| PART NUMBER | PACKAGING |
|----------------|------------|
| RB-435B | 500 pieces |

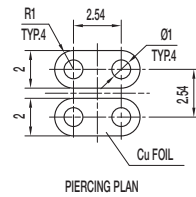
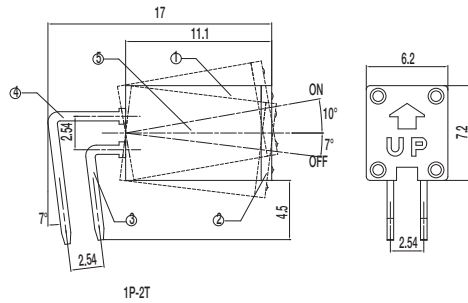

Specifications

CONTACT ARRANGEMENT: SPDT
 MINIMUM VOLTAGE: 1 VDC 10mA (resistive load)
 MAXIMUM VOLTAGE: 5 VDC 1mA (resistive load)
 OPERATING LIFE: 100,000 cycles
 INITIAL CONTACT RESISTANCE: 5 Ω max.
 INSULATION RESISTANCE: 1000 M Ω min. @ 500 VDC
 DIELECTRIC STRENGTH: 500 V AC (50-60 Hz)
 OPERATING TEMPERATURE: -20°C to +70°C

Materials

HOUSING: PA (UL94V-0)
 COVER: PA (UL94V-0)
 MOVABLE CONTACT: Copper alloy, nickel plated
 TERMINALS: Gold plated
 BALL: Steel, gold plated

| PART NUMBER | PACKAGING |
|--------------------|------------|
| RB-435X2-20 | 500 pieces |

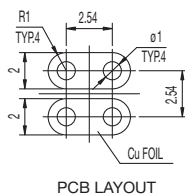
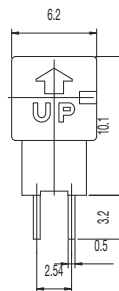
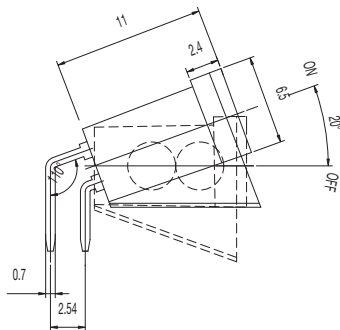
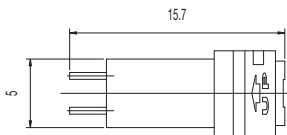

Specifications

CONTACT ARRANGEMENT: SPDT
 SENSOR ANGLE: -20° to -30° scope inside, terminal to disconnection electric current
 MINIMUM VOLTAGE: 1 VDC 10mA (resistive load)
 MAXIMUM VOLTAGE: 5 VDC 1mA (resistive load)
 OPERATING LIFE: 100,000 cycles
 INSULATION RESISTANCE: 1000 M Ω min. @ 100 VDC
 DIELECTRIC STRENGTH: 500 V AC (50-60 Hz)
 OPERATING TEMPERATURE: -20°C to +70°C

Materials

HOUSING: PBT (UL94V-0)
 COVER: PBT (UL94V-0)
 TERMINALS: Gold plated
 BALL: Steel, gold plated



Detect

RB Series Rolling Ball Sensor Switch

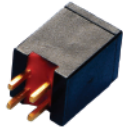

| PART NUMBER | PACKAGING |
|------------------|------------|
| RB-441-45 | 500 pieces |

Specifications

CONTACT ARRANGEMENT: SPDT
 MAXIMUM VOLTAGE: 24 VDC 25mA (resistive load)
 OPERATING LIFE: 100,000 cycles
 INSULATION RESISTANCE: 1000 M Ω min. @ 100 VDC
 DIELECTRIC STRENGTH: 500 V AC (50-60 Hz)
 OPERATING TEMPERATURE: -20°C to +70°C

Materials

HOUSING: PBT (UL94V-0)
 COVER: PBT (UL94V-0)
 TERMINALS: Gold plated
 BALL: Gold plated

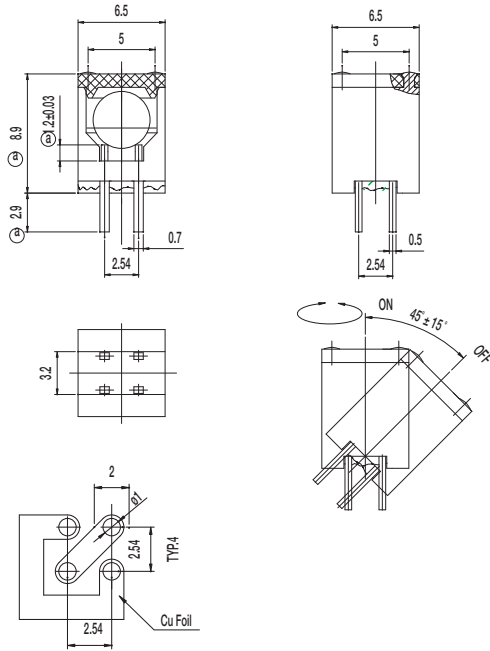

PCB LAYOUT



Detect

Features/Benefits

- Normally closed function
- Vertical detect
- Reliable long time compression
- IP54
- Tape & reel
- RoHS compliant and compatible

Typical Applications

- Smart meters
- Alarm systems
- Anti-tamper devices



Specifications

FUNCTION: Momentary action.
CONTACT TYPE: SPST Normally Closed.
TERMINALS: Gullwing type for SMT.

Mechanical

SWITCHING FORCE: ≤ 2 N
TRAVEL TO BREAK: 0,7 mm
TOTAL TRAVEL: 1,1 mm

Packaging

Switches are delivered on continuous tape, in reels of 2,000 pieces

Electrical

| | GOLD | SILVER |
|------------------------|------------|---------|
| MAXIMUM POWER: | 0.2 VA | 1 VA |
| MAXIMUM VOLTAGE: | 32 VDC | 32 VDC |
| MINIMUM VOLTAGE: | 20 mVDC | 20 mVDC |
| MAXIMUM CURRENT: | 10 mA | 50 mA |
| MINIMUM CURRENT: | 1 µA | 1 mA |
| CONTACT RESISTANCE: | ≤ 350 mΩ | |
| INSULATION RESISTANCE: | > 1 G Ω | |
| DIELECTRIC STRENGTH: | ≥ 250 Vrms | |

Environmental

| | GOLD | SILVER |
|------------------------|------------------|----------------|
| OPERATING TEMPERATURE: | -40°C to +125°C | -40°C to +85°C |
| STORAGE TEMPERATURE: | -55°C to + 125°C | -40°C to +85°C |

Process

SOLDERING: Compatible with lead free reflow process

NOTE: Specifications listed above are for switches with standard options.
For information on specific and custom switches, consult Customer Service Center.

Build-A-Switch

To order, simply select desired option from each category and place in the appropriate box. Available options are shown and described on the next page. For additional options not shown in catalog, consult Customer Service Center.

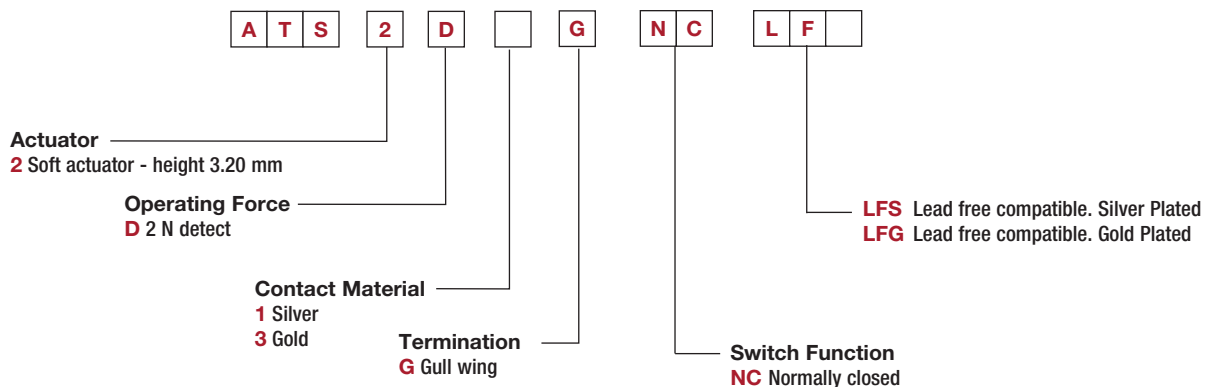

ATS Series Anti-Tampering Switches

NEW

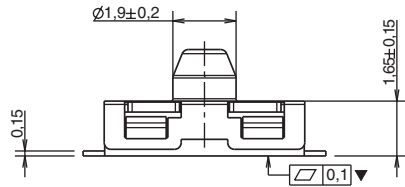

| MARKING | PART NUMBER |
|---------|-----------------|
| D - 1 | ATS 2D1G NC LFS |
| D - 3 | ATS 2D3G NC LFG |

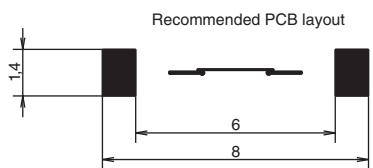
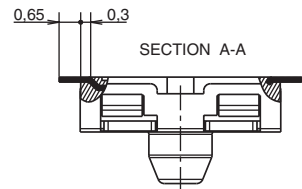
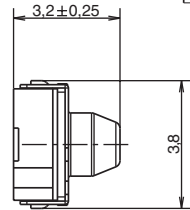
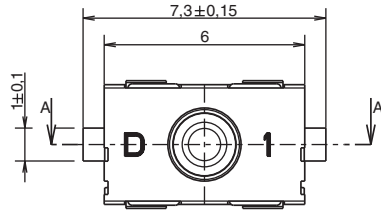

SECTION B-B



SECTION C-C

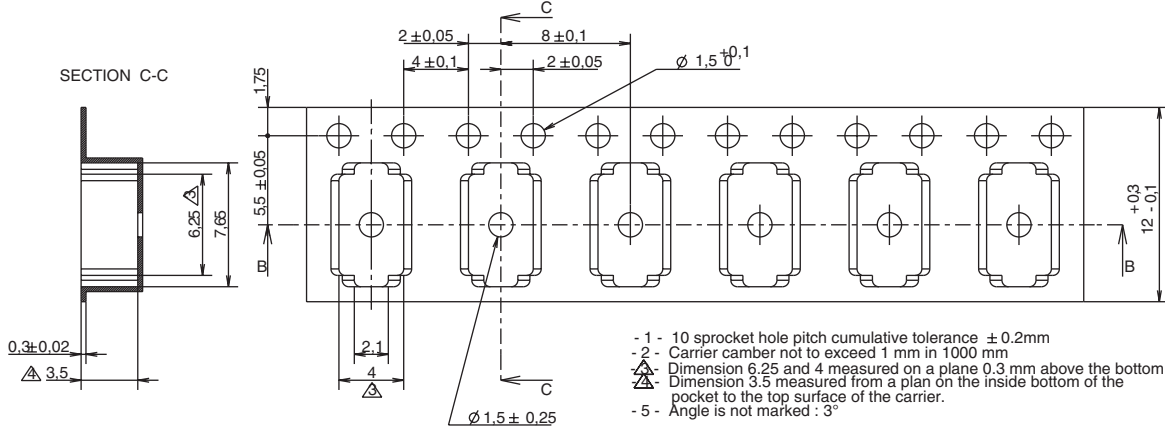

- 1 - 10 sprocket hole pitch cumulative tolerance ± 0.2mm
- 2 - Carrier camber not to exceed 1 mm in 1000 mm
- 3 - Dimension 6.25 and 4 measured on a plane 0.3 mm above the bottom of the pocket
- 4 - Dimension 3.5 measured from a plan on the inside bottom of the pocket to the top surface of the carrier.
- 5 - Angle is not marked : 3°

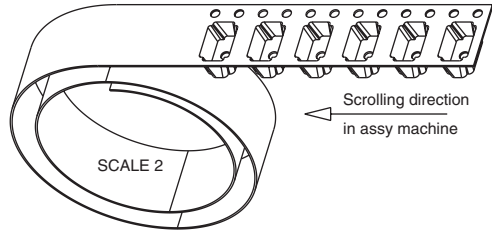

Detect



ASD Series Miniature Sealed Detect Switch

Features/Benefits

- Automotive grade
- Long 2.5 mm travel
- Quiet operation
- 300,000 electrical cycles
- IP67

Typical Applications

- Automotive - electronic door latch
- Automotive - electronic door handles



Preliminary
8 June 16

Specifications

FUNCTION: SPST NO, or SPST NC

Mechanical

| | |
|-----------------------|---------------------|
| OPERATING FORCE: | 1.5 N max. |
| FREE POSITION: | 8.75 mm * |
| OPERATING POSITION: | 7.25 mm * |
| FULL TRAVEL POSITION: | 6.25 mm * |
| MECHANICAL LIFE: | 300,000 cycles min. |
| MAX. OVERLOAD FORCE: | 20 N down |

* from post center

Electrical

| | |
|------------------------|--|
| MINIMUM RATING: | 1mA 5 VDC (silver plated contacts) |
| MAXIMUM RATING: | 250mA 14 VDC (silver contacts) |
| ELECTRICAL LIFE: | 300,000 cycles min. |
| CONTACT RESISTANCE: | 500 m Ω initial / 1 m Ω max. |
| INSULATION RESISTANCE: | 100 M Ω min. |
| DIELECTRIC STRENGTH: | 250 V min. |

Materials

FIXED CONTACTS / TERMINALS: Phosphor bronze / Silver plated
MOVABLE CONTACTS: Phosphor bronze; silver plate
BASE: PBT
COVER: PBT
ACTUATOR: Acetal

Environmental

OPERATING TEMPERATURE: - 40°C to +85°C
STORAGE TEMPERATURE: - 50°C to +95°C

Process

SOLDERING: Hand solder 300°C, 3s max.

Packaging

Switches are delivered in tray.

NOTE: Specifications listed above are for switches with standard options. For information on specific and custom switches, consult Customer Service Center.

Build-A-Switch

To order, simply select desired option from each category and place in the appropriate box. Available options are shown and described on the next page. For additional options not shown in catalog, consult Customer Service Center.

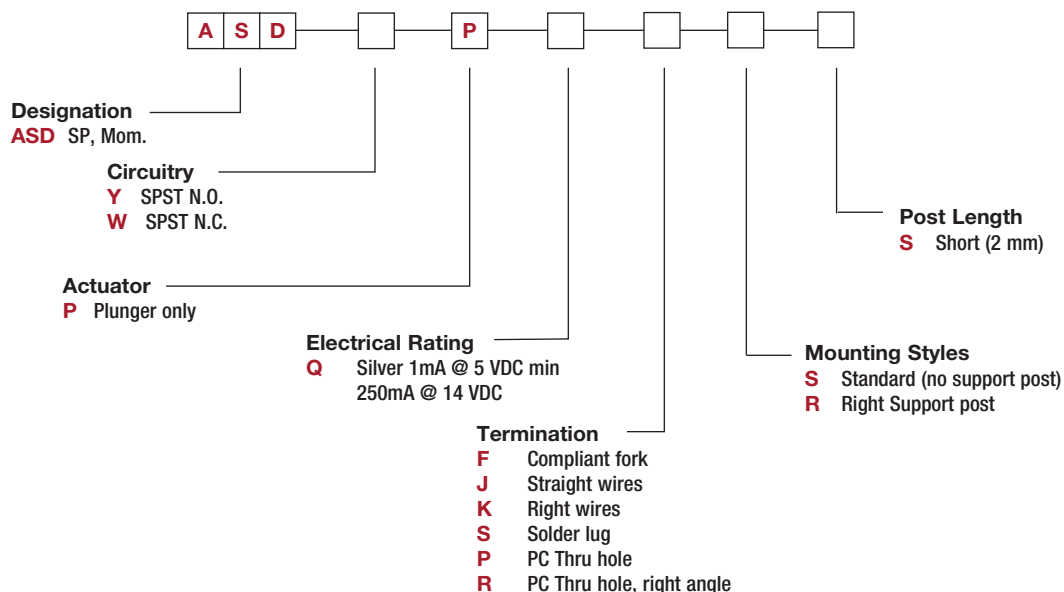

ASD Series Miniature Sealed Detect Switch

Preliminary
8 June 16

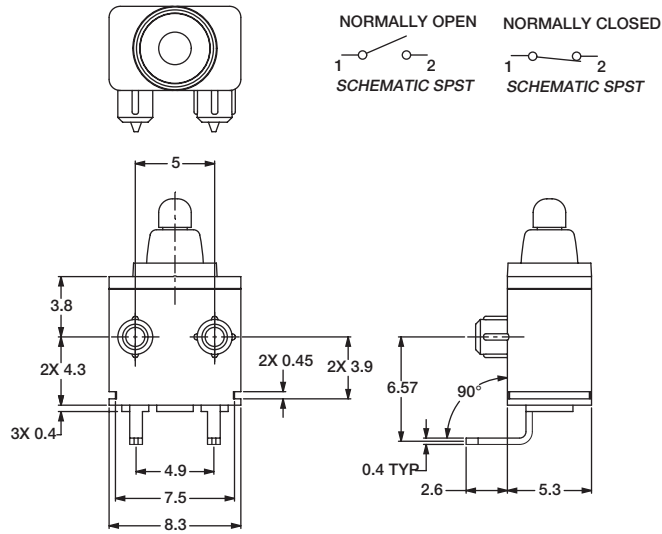

ACTUATOR

P PLUNGER ONLY

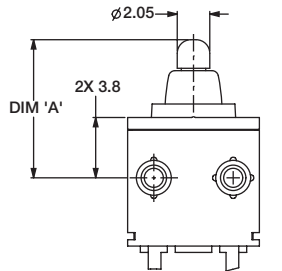

| | DIM 'A' |
|---------------|---------|
| FREE POSITION | 8.75 |
| BREAK | 7.25 |
| FULL TRAVEL | 6.25 |

TERMINATIONS

F COMPLIANT FORK

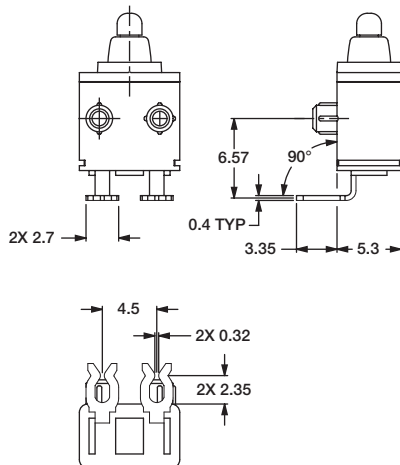

J STRAIGHT WIRES

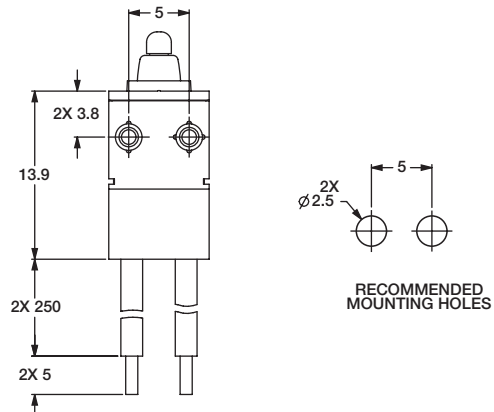

Detect



Dimensions are shown: mm
Specifications and dimensions subject to change

TERMINATIONS

K RIGHT WIRES

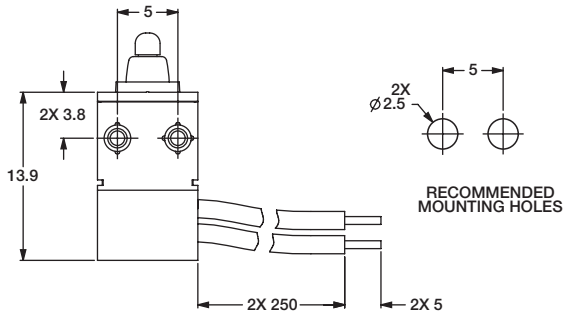

S SOLDER LUG

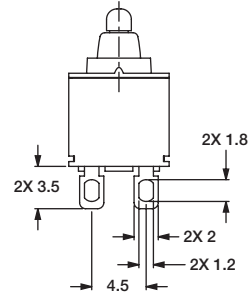

P PC THRU-HOLE

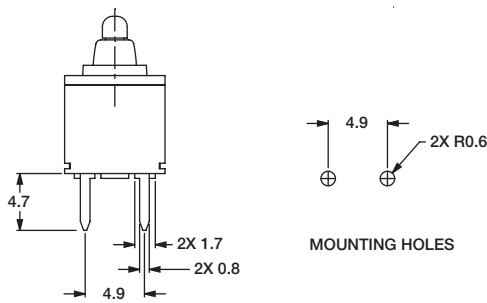

R PC THRU-HOLE - RIGHT ANGLE

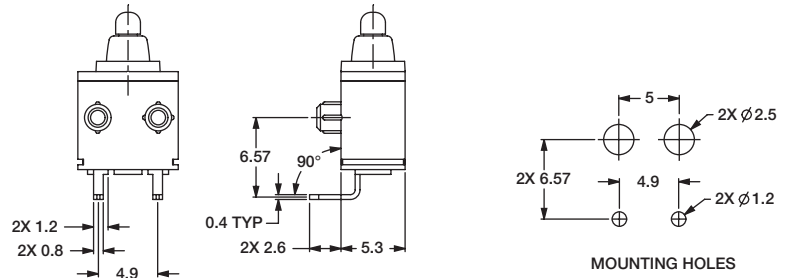

MOUNTING STYLE

S STANDARD (NO SUPPORT POST)

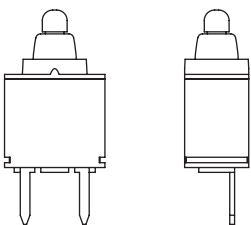



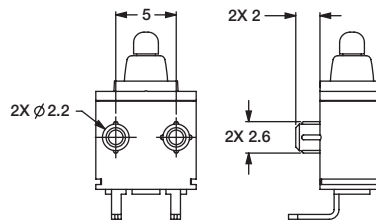



R RIGHT SUPPORT POST



Toggles

Product Selection Guide

| | | | | | | | |
|------------------------------------|---|---|---|--|---|---|---|
| Toggles |  |  |  |  |  |  |  |
| Series | 7000 | Military | E | ET | T | GT | 9000 |
| Switch Type | Miniature | Miniature | Miniature | Subminiature | Subminiature | Ultraminiature | Power |
| Poles/Throws | SPDT, DPDT, 3PDT, 4PDT | SPDT, DPDT, | SPDT, DPDT, 3PDT | SPST, SPDT, DPDT | SPST, SPDT, DPDT | SPST, SPDT, DPST, DPDT | DPDT |
| Maximum Current Silver/Gold | 5 Amps | 5 Amps | 7.5 Amps/ 5 Amps | 3 Amps/ 2 Amps | 3 Amps/ 2 Amps | 0.4 VA | 10 Amps |
| Process Sealed | | | • | • | | • | |
| PCB Mount Options | | | | | | | |
| Vertical | • | • | • | • | • | • | • |
| Right Angle | • | • | • | • | • | • | |
| Vertical Right Angle | • | • | • | • | • | • | • |
| Surface Mount Options | | | | | | | |
| Vertical | | | | | | • | |
| Right Angle | | | | • | | • | |
| Panel Mount Options | | | | | | | |
| Rear Mount | • | • | • | | • | | • |
| Termination Options | | | | | | | |
| PCB Thru-hole | • | • | • | • | • | • | • |
| Wire Wrap | • | | • | • | • | | |
| Solder Lug | • | • | • | | • | | • |
| Quick Connect | • | | • | | | | • |
| Other Available Options | | | | | | | |
| Support Brackets | • | • | • | • | • | • | • |
| Snap-in Retention | • | | • | • | | | |
| ESD Protection | • | | • | • | • | | |
| Tape & Reel | | | | • | | • | |
| Bushing Options | | | | | | | |
| 10-48 | | | | | • | | |
| 1/4-40 | • | • | • | | • | | • |
| 15/32 | • | | | | | | • |
| M6P 0.75 (Metric) | • | | | | | | |
| Page No. | F-3 | F-17 | F-22 | F-30 | F-37 | F-43 | F-48 |



Toggle
F



*Dimensions are shown: Inches (mm)
Specifications and dimensions subject to change*

7000 Series Miniature Toggle Switches

Features/Benefits

- Multi-pole and multi-position
- Wide variety of actuator and termination options
- Epoxy terminal-seal compatible with bottom wash cleaning
- RoHS complaint models available

Typical Applications

- Telecommunications
- Instrumentation
- Medical equipment

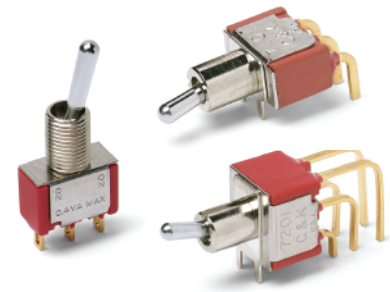

Specifications

CONTACT RATING: B contact material: 0.4 VA max. @ 20 V AC or DC max. Q contact material: 5 AMPS @ 120 V AC or 28 V DC; 2 AMPS @ 250 V AC. See page F-15 for additional ratings.

ELECTRICAL LIFE: 7X01 and UX1 models: 100,000 make-and-break cycles at full load. All other models: 40,000 cycles.

CONTACT RESISTANCE: Below 10 m Ω typ. initial @ 2-4 V DC, 100 mA, for both silver and gold plated contacts.

INSULATION RESISTANCE: 10⁹ Ω min.

DIELECTRIC STRENGTH: 1000 Vrms min. @ sea level.

OPERATING TEMPERATURE: -30°C to 85°C.

SOLDERABILITY: Per MIL-STD-202F method 208D, or EIA RS-186E method 9 (1 hour steam aging).

For materials see page F-4.

NOTE: Any models supplied with P, S, R, Q, B or G contact material are RoHS compliant and compatible.

NOTE: Specifications listed above are for switches with standard options. For information on specific and custom switches, consult Customer Service Center.

Build-A-Switch

To order, simply select desired option from each category and place in the appropriate box. Available options are shown and described on pages F-4 thru F-16. For additional options not shown in catalog, consult our Customer Service Center.

| | | | |
|--|--|---|---|
| | | | |
| <p>Switch Function</p> <p>7101 SP On-None-On 7103 SP On-Off-On 7105 SP Mom.-Off-Mom. 7107 SP On-Off-Mom. 7108 SP On-None-Mom. 7109 SP None-On-Mom. 7201 DP On-None-On 7203 DP On-Off-On 7205 DP Mom.-Off-Mom. 7207 DP On-Off-Mom. 7208 DP On-None-Mom. 7211 DP On-On-On 7213 DP On-On-Mom. 7215 DP Mom.-On-Mom. 7301 3P On-None-On 7303 3P On-Off-On 7305 3P Mom.-Off-Mom. 7308 3P On-None-Mom. 7401 4P On-None-On 7403 4P On-Off-On 7405 4P Mom.-Off-Mom. 7408 4P On-None-Mom. 7411 4P On-On-On 7413 4P On-On-Mom. 7415 4P Mom.-On-Mom.</p> <p><small>Note: UL models available, see pages F-4 & F-5.</small></p> | <p>Actuator</p> <p>M .200" high P3 Flatted, anti-rotation, .450" high S .420" high T .687" high, 15/32 bushing K2 Locking lever, .704" high K9 Locking lever, .704" high K12 Locking lever, .732" high K19 Locking lever, .732" high L .840" high L1 .640" high L1P Anti-rotation, .640" high L2 .550" high L2P Anti-rotation, .550" high L3 Plastic .940" inch L40 Lever handle without cap L41 .531" high lever handle with cap L42 .838" high lever handle with cap MP Anti-rotation, .200" high P1 Flatted, anti-rotation, .840" high P4 Flatted, anti-rotation, .250" high SP Anti-rotation, .420" high T1 .487" high, 15/32 bushing T1P Anti-rotation, .487" high, 15/32 bushing T2P Flatted, anti-rotation, .610" high, 15/32 bushing TP Anti-rotation, .687" high, 15/32 bushing</p> | <p>Bushing</p> <p>D .280 high, keyway H .296 high, flat Y .350 high, keyway NONE No bushing choice required CW Splashproof D8 .280" high, flat D9 .280" high, keyway H3 .315" high, keyway H4 8mm high, keyway Y1 .378" high, keyway Y3 8.9mm high, keyway Y4 .378" high, flat Y9 .350" high, keyway</p> <p>Terminations</p> <p>A Right angle, PC thru-hole AV2 Vert. right angle, PC thru-hole C PC Thru-hole V3 .460 high, V-bracket Z Solder lug A2 Right angle, PC thru-hole A3 Right angle, PC thru-hole A4 Right angle, PC thru-hole AW1 Right angle, extended, PC thru-hole AW4 Right angle, extended, PC thru-hole V2 .555" high, V-bracket V4 .630" high, V-bracket V6 .460" high, V-bracket V7 .630" high, V-bracket V8 .953" high, V-bracket V9 1.150" high, V-bracket V21 .555" high, snap-in V-bracket V31 .460" high, snap-in V-bracket V41 .630" high, snap-in V-bracket V71 .630" high, snap-in V-bracket V81 .953" high, snap-in V-bracket</p> | <p>Contact Material</p> <p>B Gold P Gold, matte-tin Q Silver S Silver, matte-tin G Gold over silver R Gold over silver, matte-tin</p> <p>Seal</p> <p>E Epoxy I Epoxy potted base</p> <p>Actuator Color/Finish</p> <p>NONE Bright chrome 2 Black 3 Red S Satin chrome</p> <p>KXX Actuator Color/Finish</p> <p>NONE Natural aluminum 2 Black anodized aluminum 3 Red anodized aluminum 7 Blue anodized aluminum</p> <p>Bushing Finish</p> <p>NONE Nickel on all bushings (except D8, satin chrome) 2 Black</p> <p>W .750" long, wire wrap W1 .964" long, wire wrap W3 .425" long, wire wrap W4 1.062" long, wire wrap W5 1.305" long, wire wrap Z3 Quick connect</p> |



Dimensions are shown: Inches (mm)
Specifications and dimensions subject to change

7000 Series Miniature Toggle Switches

Materials

CASE: Glass filled nylon 6/6, flame retardant, heat stabilized, or diallyl phthalate (DAP) (UL 94V-0).

ACTUATOR: Brass, chrome plated.

BUSHING: Brass or zinc, nickel plated.

HOUSING: Stainless steel.

SWITCH SUPPORT: Brass or steel, tin plated.

END CONTACTS: B contact material: Copper alloy, with gold plate over nickel plate. Q contact material: Coin silver, silver plated. See page F-15 for additional contact materials.

CENTER CONTACTS & ALL TERMINALS: B contact material: Copper alloy, with gold plate over nickel plate. Q contact material: Copper alloy, silver plated. See above for additional contact materials.

TERMINAL SEAL: Epoxy.

HARDWARE: Nut & Locking Ring: Brass, nickel plated.
Lockwasher: Steel, nickel plated.

NOTE: Materials listed above are for switches with standard options. For information on specific and custom switches, consult Customer Service Center.

SWITCH FUNCTION

| NO. POLES | MODEL NO. | UL** MODEL NO. | SWITCH FUNCTION | | | CONNECTED TERMINALS | | | SCHEMATIC |
|--|-----------|----------------|------------------|------------------|------------------|---------------------|------------------|------------------|-----------|
| | | | POS. 1 KEYWAY | POS. 2 KEYWAY | POS. 3 KEYWAY | POS. 1 KEYWAY | POS. 2 KEYWAY | POS. 3 KEYWAY | |
| SP | 7101 | U11 | ON | NONE | ON | 2-3 | N/A | 2-1 | |
| | 7103 | U13 | ON | OFF | ON | 2-3 | OPEN | 2-1 | |
| | 7105 | U15 | MOM. | OFF | MOM. | | | | |
| | 7107 | U17 | ON | OFF | MOM. | | | | |
| | 7108 | U18 | ON | NONE | MOM. | 2-3 | N/A | 2-1 | |
| 7109 | U19 | NONE | ON | MOM. | N/A | 2-3 | 2-1 | | |
| <p>SPDT</p> <p>Part number shown: 7101SYZBE</p> | | | | | | | | | |
| DP | 7201 | U21 | ON | NONE | ON | 2-3,5-6 | N/A | 2-1,5-4 | |
| | 7203 | U23 | ON | OFF | ON | 2-3,5-6 | OPEN | 2-1,5-4 | |
| | 7205 | U25 | MOM. | OFF | MOM. | | | | |
| | 7207 | U27 | ON | OFF | MOM. | | | | |
| | 7208 | U28 | ON | NONE | MOM. | 2-3,5-6 | N/A | 2-1,5-4 | |
| | 7211* | U211* | ON | ON | ON | 2-3,5-6 | 2-3,5-4 | 2-1,5-4 | |
| | 7213* | U213* | ON | ON | MOM. | | | | |
| 7215* | U215* | MOM. | ON | MOM. | | | | | |
| <p>DPDT</p> <p>Part number shown: 7201SYZQE</p> | | | | | | | | | |

MOM. = Momentary

** U11-U415 model nos. with all options when ordered with G, R, Q or S contact material.

* Wiring for 3-way switch, see Section N.



Dimensions are shown: Inches (mm)
Specifications and dimensions subject to change



7000 Series Miniature Toggle Switches

SWITCH FUNCTION

| NO. POLES | MODEL NO. | UL** MODEL NO. | SWITCH FUNCTION | | | CONNECTED TERMINALS | | | SCHEMATIC |
|-----------|-------------|----------------|-----------------|--------|--------|---------------------|--------|-------------|-----------|
| | | | POS. 1 | POS. 2 | POS. 3 | POS. 1 | POS. 2 | POS. 3 | |
| | | | KEYWAY | KEYWAY | KEYWAY | KEYWAY | KEYWAY | KEYWAY | |
| 3P | 7301 | U31 | ON | NONE | ON | 2-3,5-6,8-9 | N/A | 2-1,5-4,8-7 | |
| | 7303 | U33 | ON | OFF | ON | 2-3,5-6,8-9 | OPEN | 2-1,5-4,8-7 | |
| | 7305 | U35 | MOM. | OFF | MOM. | | | | |
| | 7307 | U37 | ON | OFF | MOM. | | | | |
| | 7308 | U38 | ON | NONE | MOM. | | | | |

3PDT

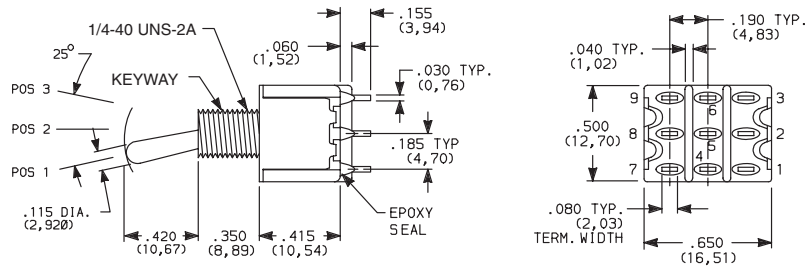

Part number shown: 7301SYZQE

Terminal Numbers
For Reference Only

| | | | | | | | | | |
|--------------|--------------|--------------|------|------|------|-------------------|------|-------------------|--|
| 4P | 7401 | U41 | ON | NONE | ON | 2-3,5-6,8-9,11-12 | N/A | 2-1,5-4,8-7,11-10 | |
| | 7403 | U43 | ON | OFF | ON | 2-3,5-6,8-9,11-12 | OPEN | 2-1,5-4,8-7,11-10 | |
| | 7405 | U45 | MOM. | OFF | MOM. | | | | |
| | 7408 | U48 | ON | NONE | MOM. | | | | |
| | 7411* | U411* | ON | ON | ON | | | | |
| | 7413* | U413* | ON | ON | MOM. | | | | |
| 7415* | U415* | MOM. | ON | MOM. | | | | | |

4PDT

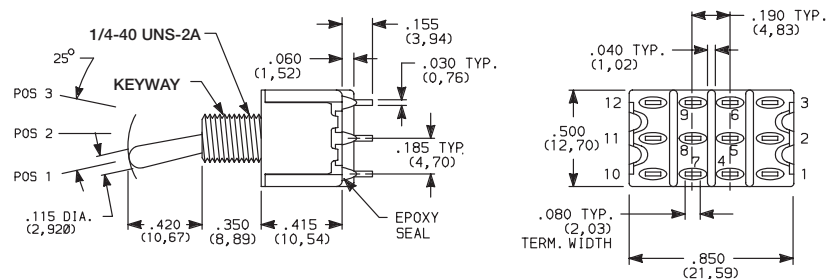

Part number shown: 7401SYZQE

Terminal Numbers
For Reference Only

MOM. = Momentary
Wiring for 3-way switch, see Section N.

** U11-U415 model nos. with all options when ordered with G, Q, R or S contact material.

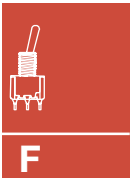

Toggle



Third Angle
Projection

Dimensions are shown: Inches (mm)
Specifications and dimensions subject to change

7000 Series Miniature Toggle Switches

ACTUATOR

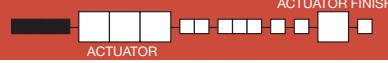

S .420" HIGH ¹
SP ANTIROTATION, .420" HIGH ^{2,3}

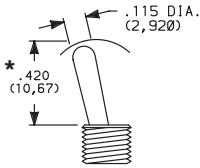

S actuator standard when ordered with C, W-W5, Z & Z3 terminations. Caps are available separately, see page F-16.

M .200" HIGH ¹
MP ANTIROTATION, .200" HIGH ^{2,3}

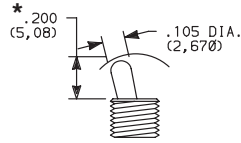

M actuator standard when ordered with all terminations except C, W-W5, Z & Z3. Caps are available separately, see page F-16.

L, L1, L2 .840", .640", .550" HIGH ¹
L1P, L2P ANTIROTATION, .840", .640", .550" HIGH ^{2,3}

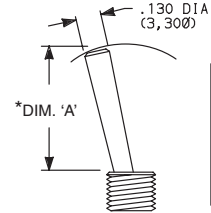

| OPTION CODE | DIM 'A' |
|-------------|--------------|
| L | .840 (21,34) |
| L1, L1P | .640 (16,26) |
| L2, L2P | .550 (13,97) |

Caps are available separately, see page F-16.

***P1** FLATTED WITH ANTIROTATION, .840" HIGH ^{2,3}

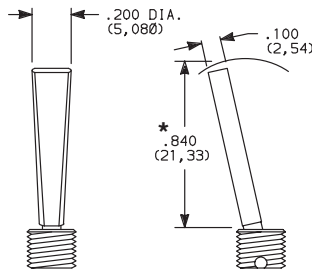

***P3** FLATTED WITH ANTIROTATION, .450" HIGH ^{2,3}

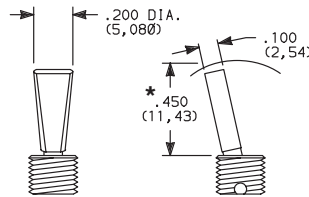

***P4** FLATTED WITH ANTIROTATION, .250" HIGH ^{2,3}

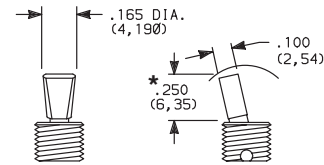

*Dress nut part number 709901201 supplied standard with threaded bushing. (Part number 709903201 with metric threaded bushings.)

T .687 (17,45) HIGH ^{1,2}
TP ANTIROTATION, .687 (17,45) HIGH, 15/32 BUSHING ^{1,2,3}

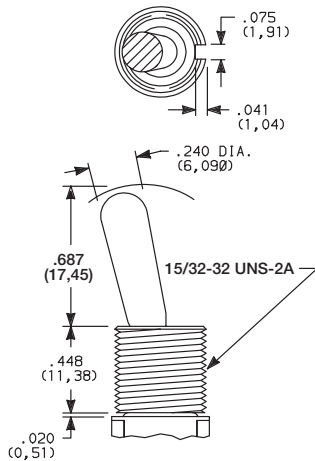

T1 .487 (12,37) HIGH ^{1,2}
T1P ANTIROTATION, .487 (12,37) HIGH, 15/32 BUSHING ^{1,2,3}

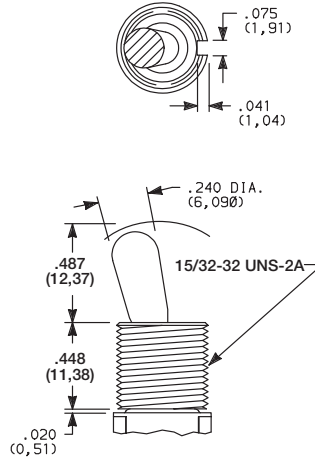

T2P FLATTED, ANTIROTATION, .610" HIGH, 15/32 BUSHING ^{1,2,3}

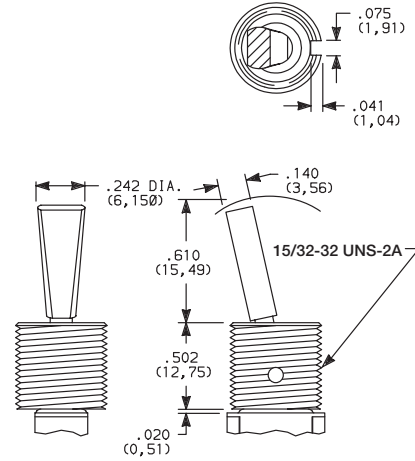

Bushing option code not required unless CW splashproof bushing ordered. TP & T1P actuators not available with CW splashproof bushing. All TXX actuators not available on single pole models with A-A4, AW1-AW4 terminations.

Bushing option code not required. T2P actuator not available with CW splashproof bushing or single pole models with A-A4, AW1-AW4 terminations.

- ¹ L, L1, L2, M, S & TXX actuators not available with Y1 bushing.
 - ² L1P, L2P, MP, P1, P3, P4, SP & TXX actuators not available with D8 & H4 bushing.
 - ³ Antirotation: Provides anti-'push-in' feature on actuator.
- * Add .070 (1,78) for D, D8 & D9 bushings, subtract .020 (0,51) for H3 bushing.

| OPTION CODE | ACTUATOR FINISH |
|-------------|--|
| NONE | BRIGHT CHROME-With Nickel Plated Bushing |
| 2 | BLACK |
| S | SATIN CHROME |

NOTE: Black hardware is supplied when either black actuators or bushings are specified. For additional hardware, see Section N.

Toggle

F

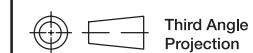

Dimensions are shown: Inches (mm)
 Specifications and dimensions subject to change

7000 Series Miniature Toggle Switches

ACTUATOR

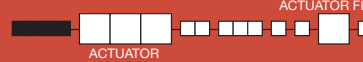

- K2** LOCKING LEVER, .704" HIGH (threaded)
- K9** LOCKING LEVER, .704" HIGH (unthreaded)

- K12** LOCKING LEVER, .732" HIGH (threaded)
- K19** LOCKING LEVER, .732" HIGH (unthreaded)

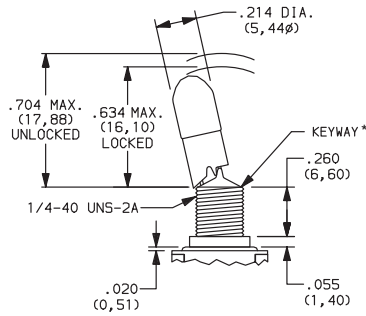

Replaces K, K8

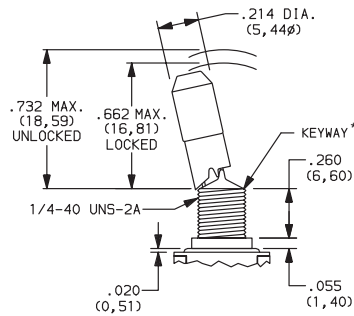

Replaces K1, K18

| OPTION CODE | ACTUATOR CAP FINISH |
|-------------|---|
| NONE | NATURAL ALUMINUM—With Nickel Plated Bushing |
| 2 | BLACK ANODIZED ALUMINUM |
| 3 | RED ANODIZED ALUMINUM |
| 7 | BLUE ANODIZED ALUMINUM |

* All KXX models including KXXCW have a keyway

Locking Positions



-01 Models
2 Position lock

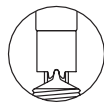

-03 & -11 Models
3 Position lock



-05, -09 & -15 Models
1 Position lock



-07 & -13 Models
2 Position lock



-08 Models
1 Position lock

NOTE: To prevent accidental actuation, toggle must be lifted before being actuated. When released, toggle will lock in place. Overtightening mounting nut may cause actuator to bind.

Locking levers supplied with bushing shown.

Bushing option code not required unless CW splashproof bushing ordered.

- L40** LEVER HANDLE WITHOUT CAP

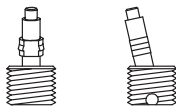

No color choice required

- L41** PLASTIC LEVER HANDLE WITH ANTIROTATION AND CAP, P/N 4810

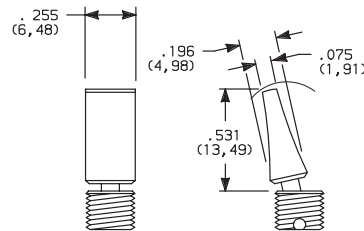

Finish: Matte (L41 & L42).

- L42** PLASTIC LEVER HANDLE WITH ANTIROTATION AND CAP, P/N 4811

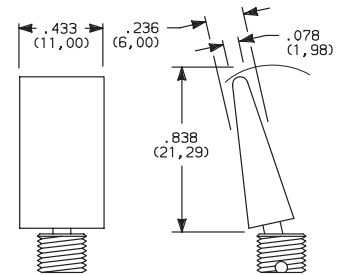

- L3** PLASTIC .940" HIGH

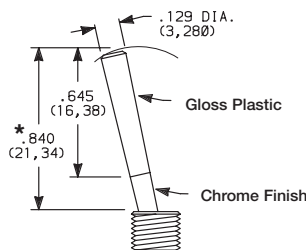

| OPTION CODE | PLASTIC ACTUATOR COLORS |
|-------------|--------------------------------|
| NONE | No Actuator Color (L40 option) |
| 2 | BLACK |
| 3 | RED |

* Add .070 (1,78) for D, D8 & D9 bushings, subtract .020 (0,51) for H3 bushing.

NOTE: Lever handle for L41 & L42 actuators supplied, but not installed. For interchangeability, order L40 actuator option and lever handles separately, see page F-16. L4X actuators not available with H4, Y1, Y4 bushings. Antirotation: Provides anti-'push-in' feature on actuator.



Third Angle Projection

Dimensions are shown: Inches (mm)
Specifications and dimensions subject to change

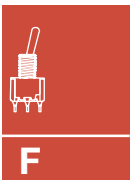

7000 Series Miniature Toggle Switches

BUSHING

BUSHING FINISH

BUSHING

Y .350" HIGH, THREADED, KEYWAY
Y9 .350" HIGH, UNTHREADED, KEYWAY

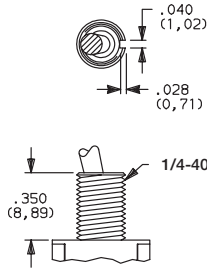

Y bushing standard with C, W-W5, Z or Z3 terminations.

NONE NO BUSHING

No bushing choice required with KXX, TXX actuators. (exception: Specify CW if splashproof bushing desired).

D .280" HIGH, THREADED, KEYWAY
D8 .280" HIGH, UNTHREADED, FLAT³
D9 .280" HIGH, UNTHREADED, KEYWAY

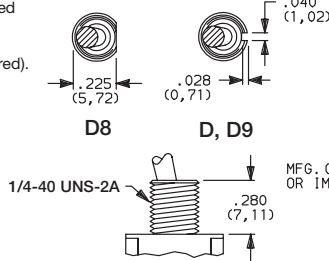

D9 bushing standard with all terminations except C, W-W5, Z or Z3. Add .070 (1,78) to all actuators lengths with D, D8 & D9 bushings.

H .296" HIGH, FLAT THREADED, HIGH TORQUE^{1,2}

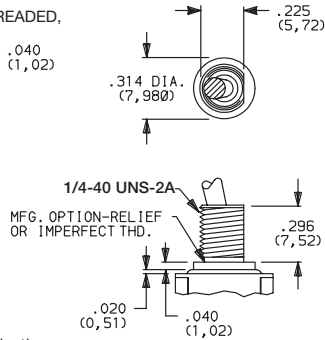

H3 .315" HIGH, KEYWAY THREADED, HIGH TORQUE^{1,2}

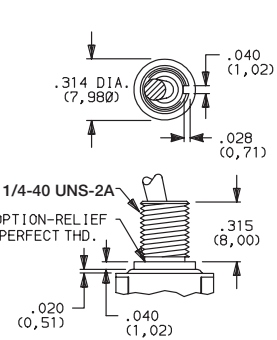

Subtract .020 (0,51) from all actuator lengths for H3 bushing.

H4 8mm HIGH, KEYWAY, THREADED, METRIC HIGH TORQUE^{1,2,3}

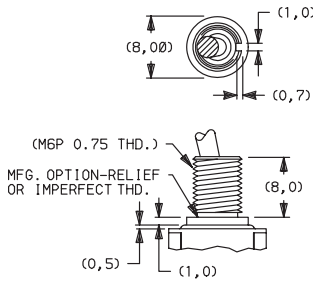

Y1 .378" HIGH, KEYWAY, THREADED, HIGH TORQUE^{1,2,4}

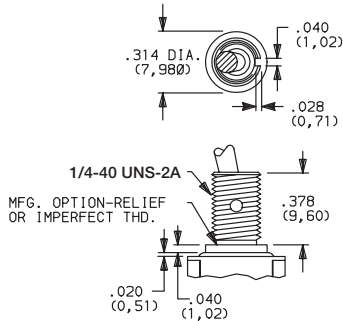

Y3 8.9mm HIGH, KEYWAY, THREADED, METRIC

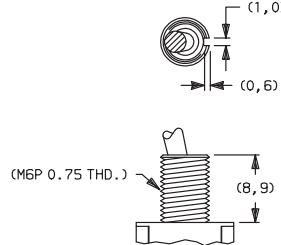

Y4 .378" HIGH, FLAT, THREADED, HIGH TORQUE^{1,2,5}

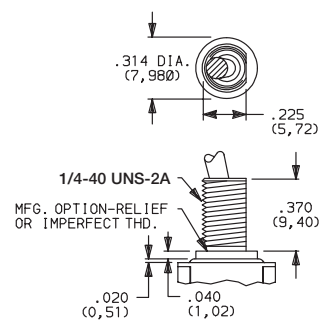

CW THREADED, SPLASHPROOF^{1,2}
For T & T1 actuators.

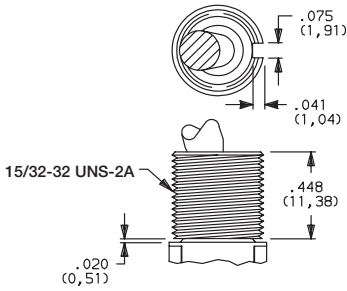

IP67 Degree of protection, totally protected against dust, full-scale voltage protection, temporary immersion. Internal actuator seal standard. External bushing seal available separately from APM Hexseal, part # MFS-60064.

For actuators other than T, T1 and KXX.

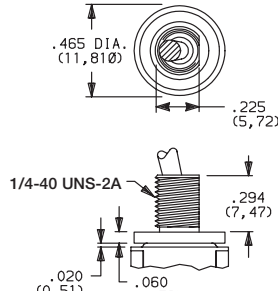

IP67 Degree of protection, totally protected against dust, full-scale voltage protection, temporary immersion. Internal actuator seal and external bushing seal washer standard. IP65 degree of protection for LXP, MP, PX or SP with CW option.

| OPTION CODE | BUSHING FINISH |
|-------------|--|
| NONE | NICKEL on all bushings except 'D8' satin chrome. |
| 2 | BLACK |

- Will withstand 12 in.-lbs. of torque with no distortion.
- CW, H, H3, H4, Y1 & Y4 bushings not available on single pole models with A4 terminations.
- D8 & H4 bushings available only with L, L1, L2, M & S actuators.
- Y1 bushing available only with LXP, MP, PX & SP actuators.
- Y4 bushing not available with L4X actuators.

NOTE: Two mounting nuts, locking ring and lockwasher supplied standard with threaded bushings. Black hardware is supplied when either black bushings or actuators are specified. Optional mounting nut and locking ring styles and finishes available, see Section N.

PANEL MOUNTING

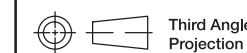
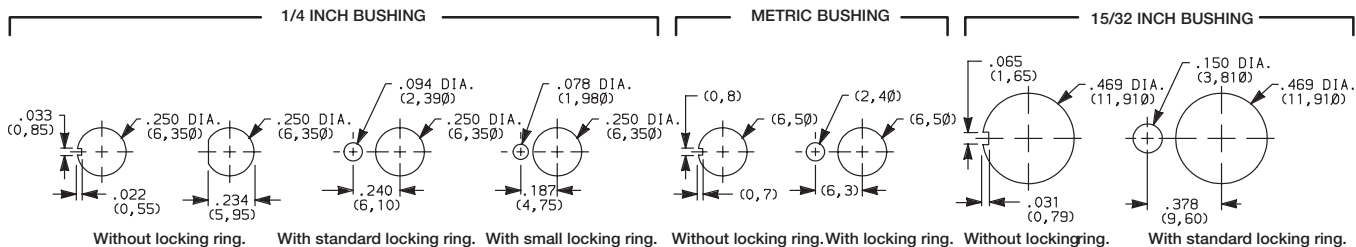

Dimensions are shown: Inches (mm)
Specifications and dimensions subject to change

Toggle
F

C&K

7000 Series Miniature Toggle Switches

TERMINATIONS

Z SOLDER LUG

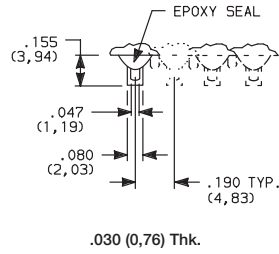

C PC THRU-HOLE

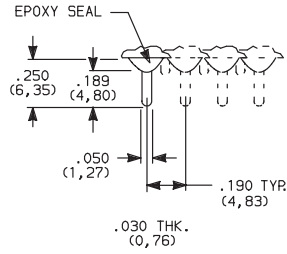

PC MOUNTING

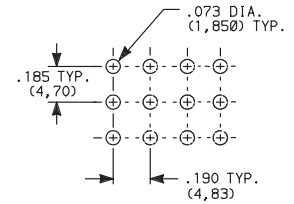

SPDT thru 4PDT

Not available with P, R or S contact materials.

SPDT thru 4PDT

Z3 QUICK CONNECT

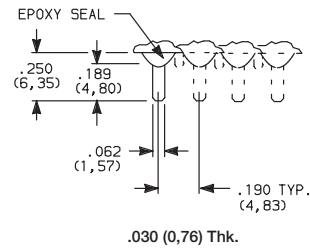

W, W1, W3, W4, W5 WIRE WRAP

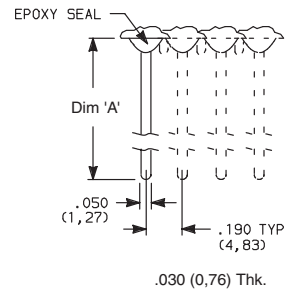

| OPTION CODE | DIM 'A' |
|-------------|---------------|
| W | .750 (19,05) |
| W1 | .964 (24,48) |
| W3 | .425 (10,80) |
| W4 | 1.062 (26,97) |
| W5 | 1.305 (33,15) |

SPDT thru 4PDT

Not available with P, R or S contact materials.
Mating quick connector available, order part number 530100000, page F-16.

SPDT thru 4PDT

A RIGHT ANGLE, PC THRU-HOLE

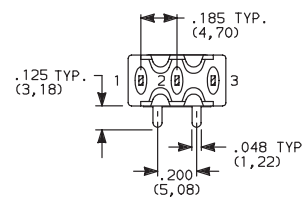
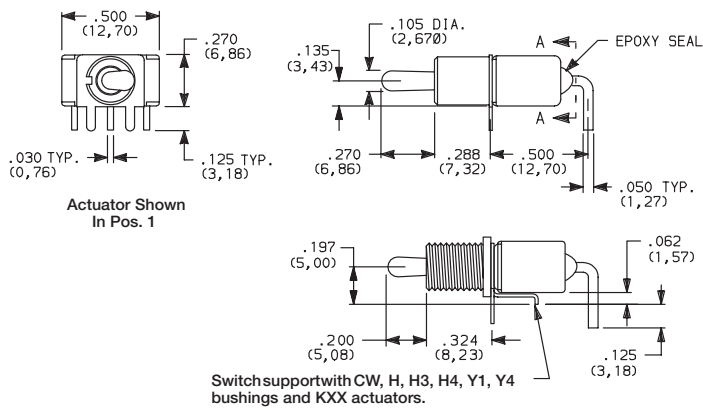

SECTION A-A

Terminal Nos.
For Reference Only

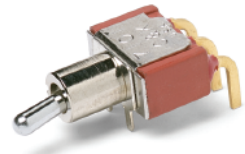

7101MD9ABE
Horizontal Actuation
SPDT

Part No. Shown: 7101MHABE

A3 RIGHT ANGLE, SNAP-IN, PC THRU-HOLE

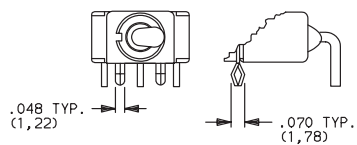

AW1, AW4 RIGHT ANGLE, EXTENDED, PC THRU-HOLE

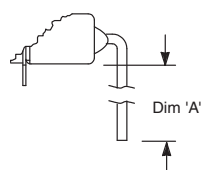

| OPTION CODE | DIM 'A' |
|-------------|------------|
| AW1 | .72 (18,3) |
| AW4 | .83 (21,1) |

PC MOUNTING

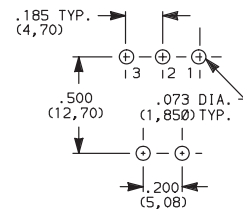

Not available with I seal option.
Terminal bend radii and lead-in manufacturing option.

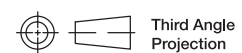

Third Angle
Projection

Dimensions are shown: Inches (mm)
Specifications and dimensions subject to change

www.ck-components.com

C&K



Toggle

7000 Series Miniature Toggle Switches

TERMINATIONS

A RIGHT ANGLE, PC THRU-HOLE

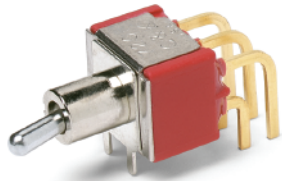

7201MD9ABE
Horizontal Actuation
DPDT

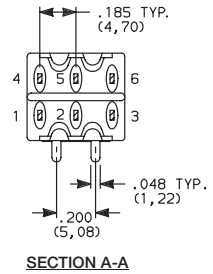
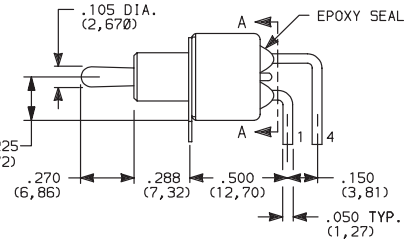
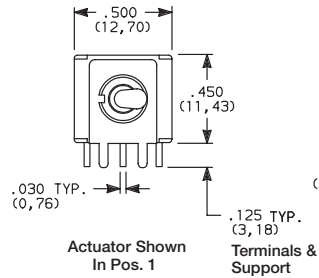

A3 RIGHT ANGLE, SNAP-IN, PC THRU-HOLE

AW1, AW4 RIGHT ANGLE, EXTENDED, PC THRU-HOLE

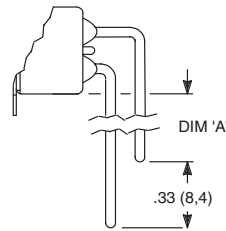
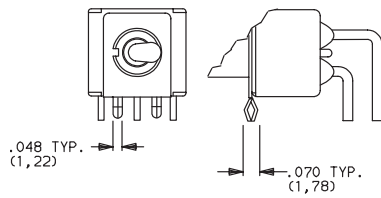

| OPTION CODE | DIM 'A' |
|-------------|------------|
| AW1 | .40 (10,2) |
| AW4 | .50 (12,7) |

PC MOUNTING

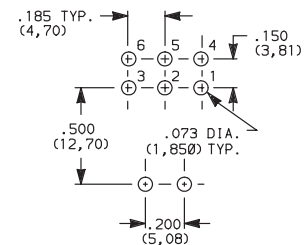

Not available with I seal option.
Terminal bend radii and lead-in manufacturing option.

A RIGHT ANGLE, PC THRU-HOLE

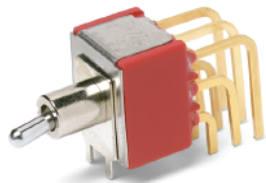

7301MD9ABE
Horizontal Actuation
3PDT

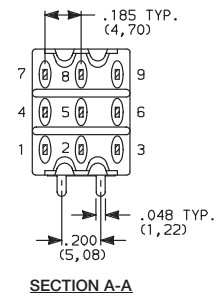
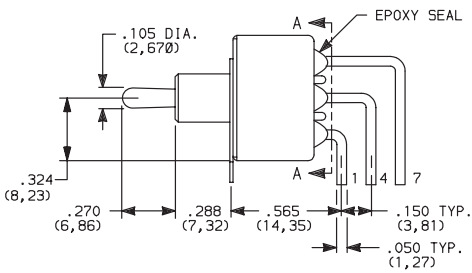
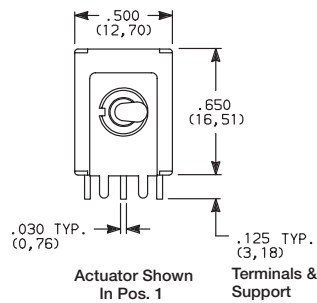

AW4 RIGHT ANGLE, EXTENDED, PC THRU-HOLE

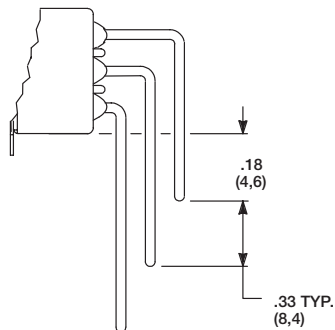

PC MOUNTING

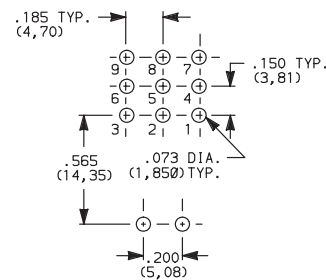

Not available with I seal option.
Terminal bend radii and lead-in manufacturing option.



Toggle



Dimensions are shown: Inches (mm)
Specifications and dimensions subject to change

7000 Series Miniature Toggle Switches

TERMINATIONS

A2 RIGHT ANGLE, PC THRU-HOLE,
.156" PITCH

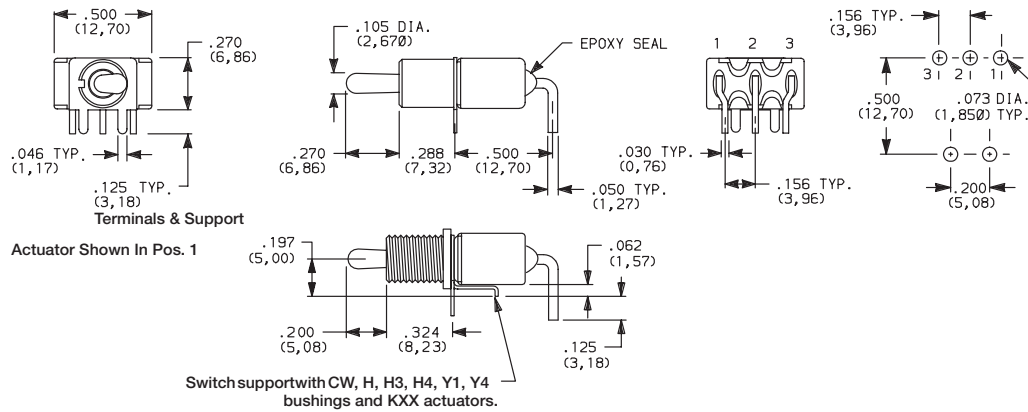

7101MHA2BE
Horizontal Actuation
SPDT

Not available with TXX actuators and I seal.
Terminal bend radii and lead-in manufacturing option. Part No. Shown: 7101MHA2BE

A4 RIGHT ANGLE, PC THRU-HOLE
.156" PITCH

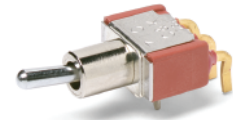
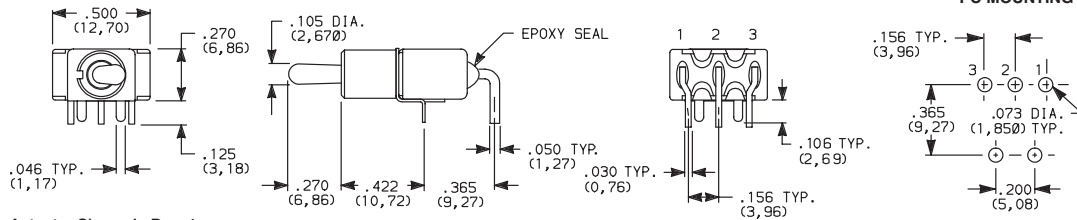

7101MD9A4BE
Horizontal Actuation
SPDT

Not available with KXX & TXX actuators, CW, H, H3, H4, Y1 & Y4 bushings, and I seal. Terminal bend radii and lead-in manufacturing option.

NOTE: The A4 option is available with any contact material and can be UL recognized and CSA certified. The PC pattern must clear switch support legs.

AV2 VERTICAL RIGHT ANGLE, PC THRU-HOLE,
.150" PITCH

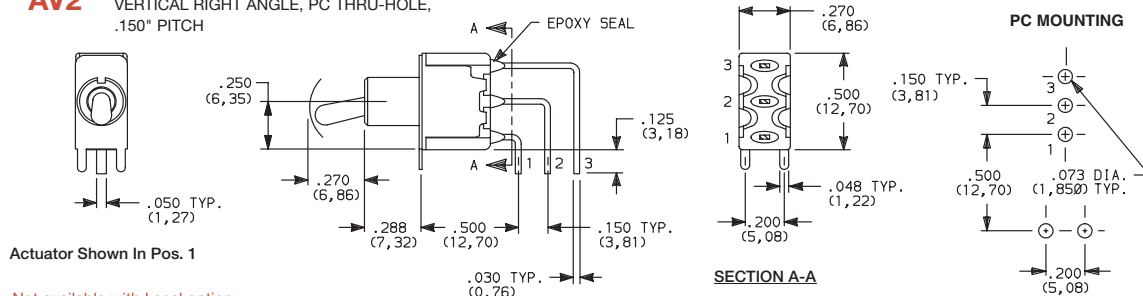

7101MD9AV2BE
Horizontal Actuation
SPDT

Not available with I seal option.
Terminal bend radii and lead-in manufacturing option.

AV2 VERTICAL RIGHT ANGLE, PC THRU-HOLE,
.150" PITCH

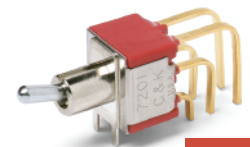
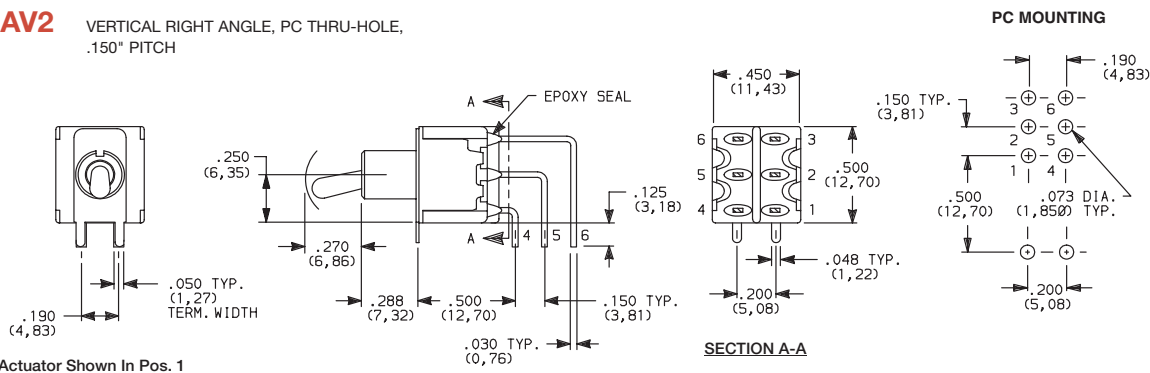

7201MD9AV2BE
Vertical Actuation
DPDT

Not available with I seal option.
Terminal bend radii and lead-in manufacturing option.



Third Angle
Projection



Dimensions are shown: Inches (mm)
Specifications and dimensions subject to change

www.ck-components.com

7000 Series Miniature Toggle Switches

TERMINATIONS

AV2 VERTICAL RIGHT ANGLE, PC THRU-HOLE,
.150" PITCH

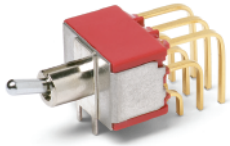

7301MD9AV2BE
Vertical Actuation
3PDT

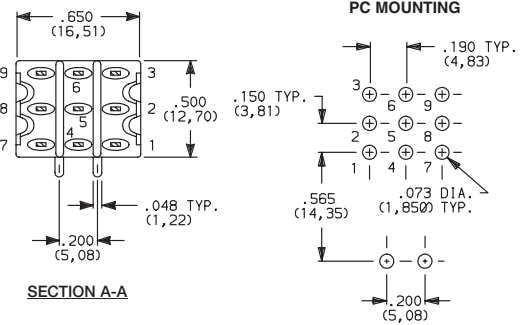
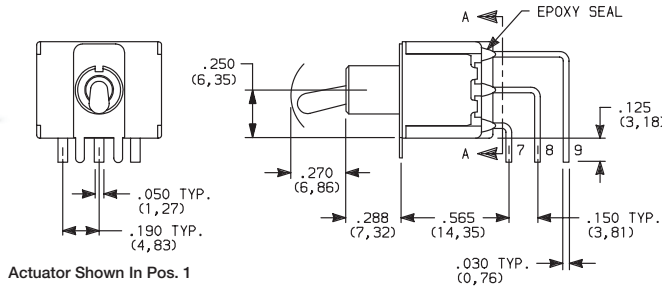

Not available with I seal option.
Terminal bend radii and lead-in manufacturing option.

AV2 VERTICAL RIGHT ANGLE, PC THRU-HOLE,
.150" PITCH

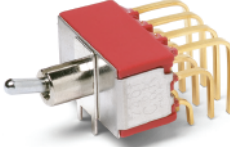

7401MD9AV2BE
Vertical Actuation
4PDT

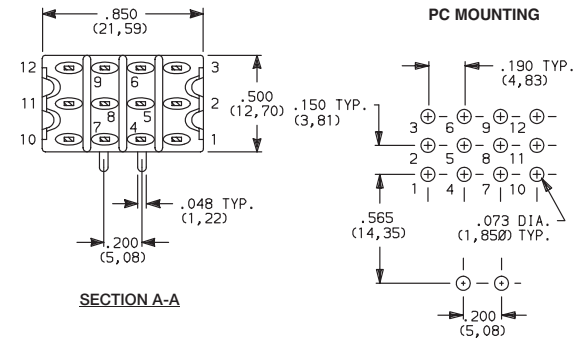
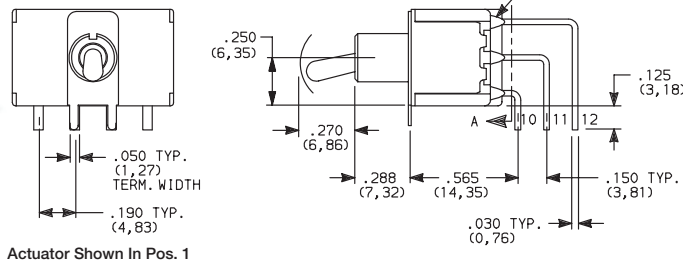

Not available with I seal option.
Terminal bend radii and lead-in manufacturing option.

V2, V6, V7, V8 VERTICAL MOUNT, V-BRACKET

V21, V71, V81 VERTICAL MOUNT, V-BRACKET, SNAP-IN

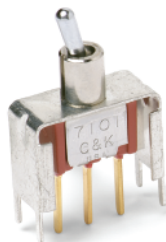

7101MD9_BE
SPDT

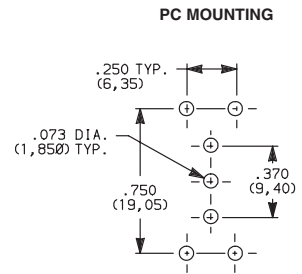
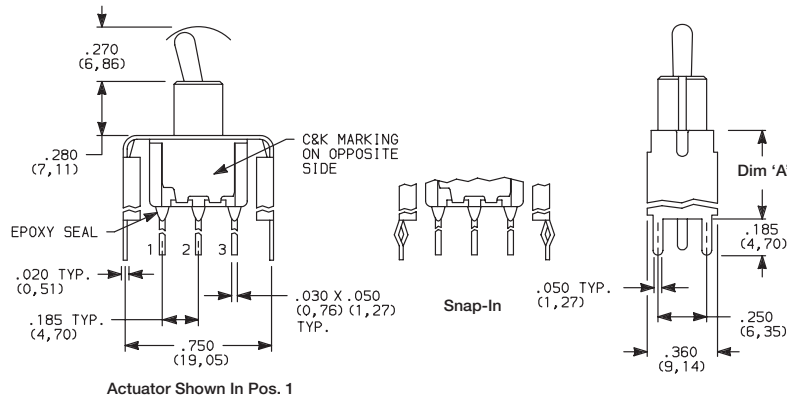

| OPTION CODE | DIM 'A' |
|----------------|--------------|
| V2, V21 | .555 (14,10) |
| V6 | .460 (11,68) |
| V7, V71 | .630 (16,00) |
| V8, V81 | .953 (24,21) |

Not available with I seal option.

Toggle



Dimensions are shown: Inches (mm)
Specifications and dimensions subject to change

7000 Series Miniature Toggle Switches

TERMINATIONS

V2, V6, V7, V8 VERTICAL MOUNT, V-BRACKET

V21, V61, V71, V81 VERTICAL MOUNT, V-BRACKET, SNAP-IN

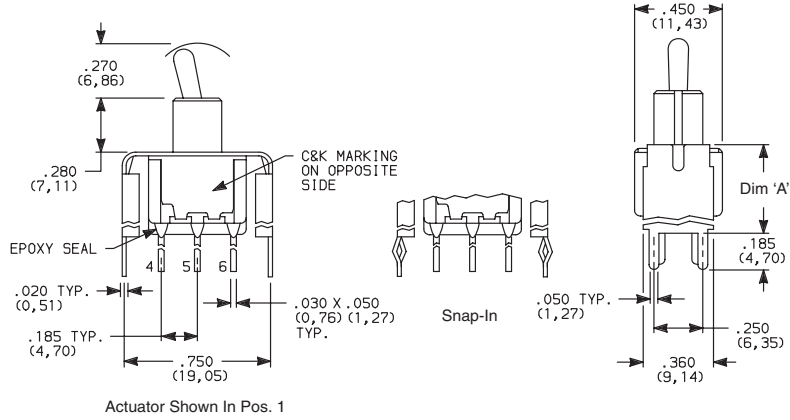

Actuator Shown In Pos. 1
Not available with I seal option.

PC MOUNTING

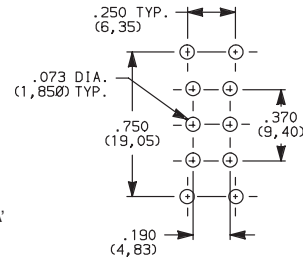

| OPTION CODE | DIM 'A' |
|----------------|--------------|
| V2, V21 | .555 (14,10) |
| V6, V61 | .460 (11,68) |
| V7, V71 | .630 (16,00) |
| V8, V81 | .953 (24,21) |

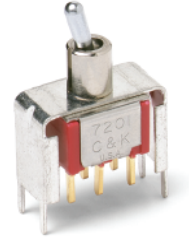

7201MD9_BE
DPDT

V2, V7, V8 VERTICAL MOUNT, V-BRACKET

V21, V71, V81 VERTICAL MOUNT, V-BRACKET, SNAP-IN

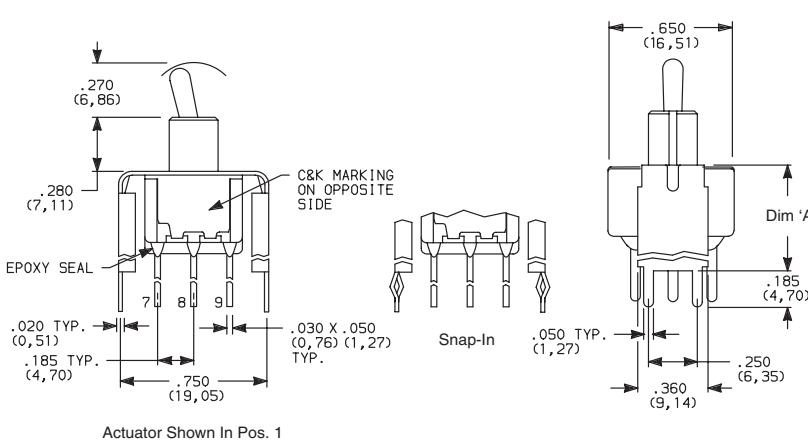

Actuator Shown In Pos. 1
Not available with I seal option.

PC MOUNTING

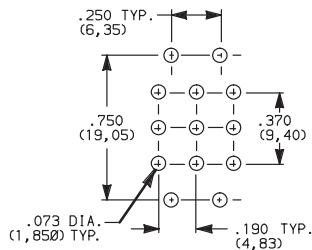

| OPTION CODE | DIM 'A' |
|----------------|--------------|
| V2, V21 | .555 (14,10) |
| V7, V71 | .630 (16,00) |
| V8, V81 | .953 (24,21) |

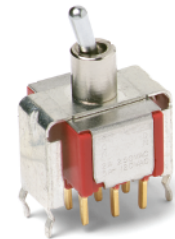

7301MD9_BE
3PDT

V2, V7, V8 VERTICAL MOUNT, V-BRACKET

V21, V71, V81 VERTICAL MOUNT, V-BRACKET, SNAP-IN

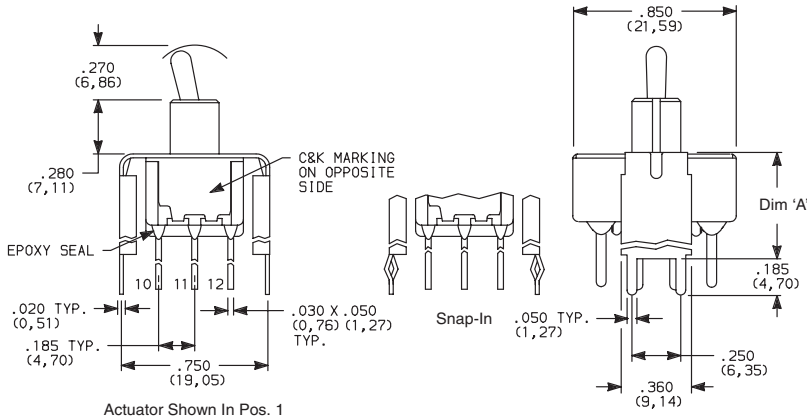

Actuator Shown In Pos. 1
Not available with I seal option.

PC MOUNTING

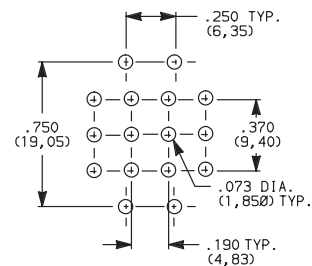

| OPTION CODE | DIM 'A' |
|----------------|--------------|
| V2, V21 | .555 (14,10) |
| V7, V71 | .630 (16,00) |
| V8, V81 | .953 (24,21) |

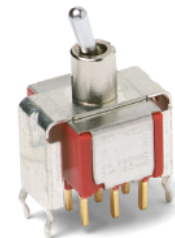

7401MD9_BE
4PDT



Third Angle Projection
Dimensions are shown: Inches (mm)
Specifications and dimensions subject to change



7000 Series Miniature Toggle Switches

TERMINATIONS

V3, V4, V9 VERTICAL MOUNT, V-BRACKET

V31, V41 VERTICAL MOUNT, V-BRACKET, SNAP-IN

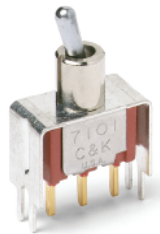

7101MD9_BE
SPDT

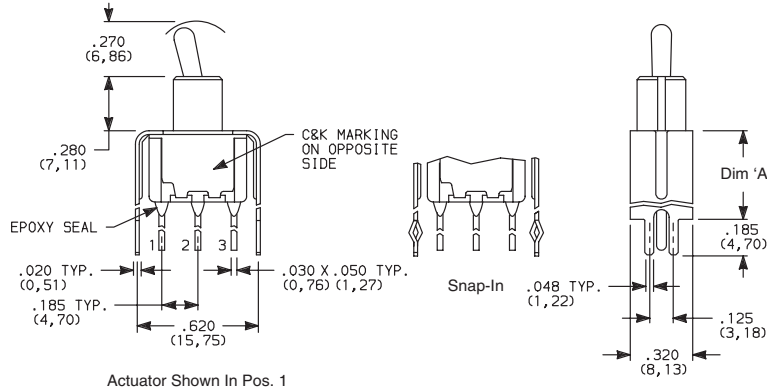

PC MOUNTING

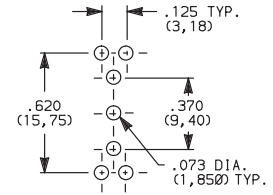

| OPTION CODE | DIM 'A' |
|----------------|---------------|
| V3, V31 | .460 (11,68) |
| V4, V41 | .630 (16,00) |
| V9 | 1.150 (29,21) |

Not available with I seal option.

V3, V4, V9 VERTICAL MOUNT, V-BRACKET

V31, V41 VERTICAL MOUNT, V-BRACKET, SNAP-IN

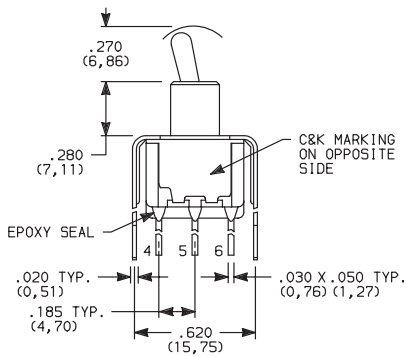

7201MD9_BE
DPDT

PC MOUNTING

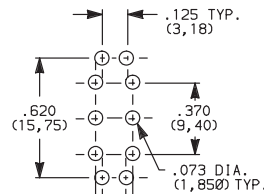

| OPTION CODE | DIM 'A' |
|----------------|---------------|
| V3, V31 | .460 (11,68) |
| V4, V41 | .630 (16,00) |
| V9 | 1.150 (29,21) |

Not available with I seal option.

V4, V9 VERTICAL MOUNT, V-BRACKET

V41 VERTICAL MOUNT, V-BRACKET, SNAP-IN

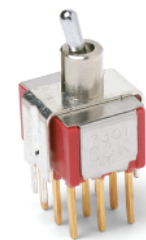
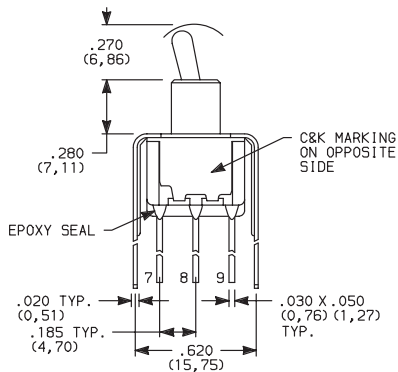

7301MD9_BE
3PDT

PC MOUNTING

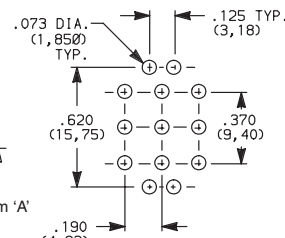

| OPTION CODE | DIM 'A' |
|----------------|---------------|
| V4, V41 | .630 (16,00) |
| V9 | 1.150 (29,21) |

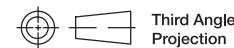

Third Angle Projection
Dimensions are shown: Inches (mm)
Specifications and dimensions subject to change

www.ck-components.com



Toggle



7000 Series Miniature Toggle Switches

TERMINATIONS

V4, V9 VERTICAL MOUNT, V-BRACKET

V41 VERTICAL MOUNT, V-BRACKET, SNAP-IN

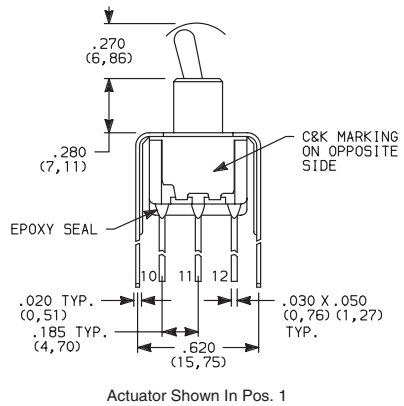

Actuator Shown In Pos. 1

Not available with I seal option.

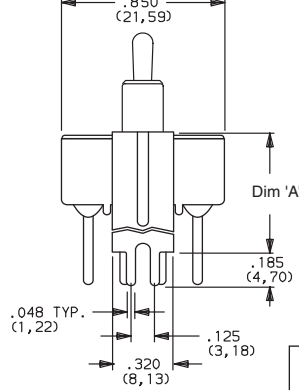
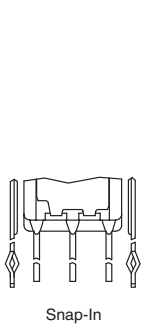

PC MOUNTING

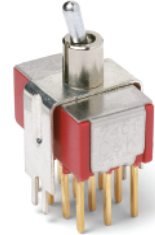
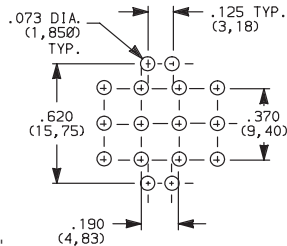

7401MD9_BE
4PDT

| OPTION CODE | DIM 'A' |
|----------------|---------------|
| V4, V41 | .630 (16,00) |
| V9 | 1.150 (29,21) |

CONTACT MATERIAL

| OPTION CODE | CONTACT MATERIAL | TERMINAL PLATING | RATINGS | |
|-------------|------------------------------------|------------------------|-----------------------------------|--|
| | | | | |
| B | GOLD ¹ | GOLD ¹ | LOW LEVEL/ DRY CIRCUIT | 0.4 VA MAX. @ 20 V AC OR DC MAX. |
| P | | MATTE-TIN ⁶ | | |
| Q | SILVER ^{4,5} | SILVER ⁵ | POWER | 5 AMPS @ 120 V AC OR 28 V DC; 2 AMPS @ 250 V AC. |
| S | | MATTE-TIN ⁶ | | |
| G | GOLD OVER SILVER ^{2,3} | GOLD ³ | LOW LEVEL/DRY CIRCUIT OR POWER | 0.4 VA MAX @ 20 V AC OR DC MAX. OR 5 AMPS @ 120 V AC OR 28 V DC; 2 AMPS @ 250 V AC. |
| R | | MATTE-TIN ⁶ | | |

* Note: See Technical Data section of this catalog for RoHS compliant and compatible definitions and specifications.

¹ CONTACTS & TERMINALS: Copper alloy, with gold plate over nickel plate.

² END CONTACTS: Coin silver, with gold plate over nickel plate.

³ CENTER CONTACTS & ALL TERMINALS: Copper alloy, with gold plate over nickel plate.

⁴ END CONTACTS: Coin silver, silver plated.

⁵ CENTER CONTACT & ALL TERMINALS: Copper alloy, silver plated.

⁶ TERMINALS: Copper alloy, with matte tin alloy nickel plate.

NOTE: Any models supplied with P, S, R, Q, B or G contact material are RoHS compliant.

U11-U415 model numbers  with all options when ordered with G, S, R, or Q contact material.

B contact material standard with all terminations except C, Z & Z3.

Q contact material standard with C, Z & Z3 terminations.

P, S & R contact materials not available with Z & Z3 terminations.

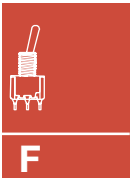

7000 Series Miniature Toggle Switches

SEAL

E EPOXY SEAL

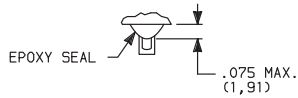

Compatible with "bottom-wash" PC board cleaning methods.

I EPOXY POTTED BASE

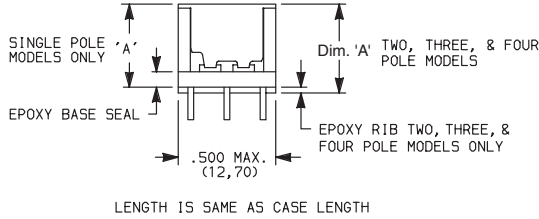

| NO. POLES | DIM 'A' |
|-----------|--------------|
| SP | .410 (10,41) |
| DP | .440 (11,18) |
| 3P | .505 (12,83) |
| 4P | .505 (12,83) |

Available with C, W-W5, Z & Z3 terminations only.

AVAILABLE HARDWARE

Cap

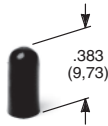

PART NO.

896801000 WHITE
896802000 BLACK
896803000 RED

Material: Polyethylene
Finish: Matte

Cap

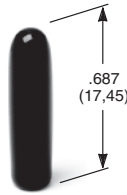

PART NO.

763701000 WHITE
763702000 BLACK
763703000 RED

Material: Vinyl
Finish: Matte

Cap

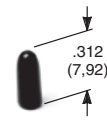

PART NO.

706201000 WHITE
706202000 BLACK
706203000 RED

Material: Vinyl
Finish: Matte

L41 Lever handle

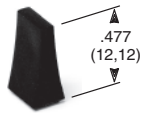

PART NO.

481001000 WHITE
481002263 BLACK
481003000 RED

Material: Nylon
Finish: Matte

L42 Lever handle

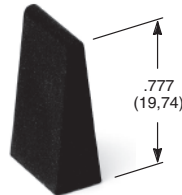

PART NO.

481101000 WHITE
481102263 BLACK
481103000 RED

Material: Nylon
Finish: Matte

Fits Z3 Termination female connector



PART NO.

530100000

Available in loose pieces.

NOTE: Additional nuts, locking rings and lockwashers available separately, see Section N.

Other colors available, consult Customer Service Center.

759D02000 Sealing Boot

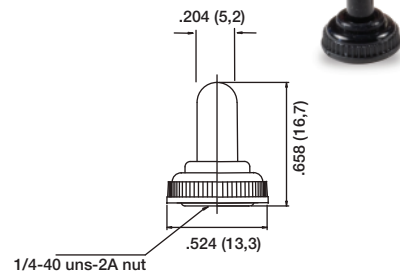

NOTE: For use with S actuator style when combined with D, H, H3, Y, and Y4 bushings

703D02000 Sealing Boot

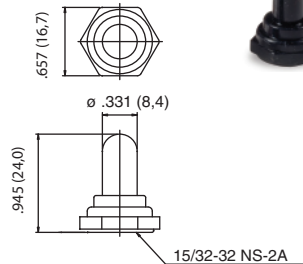

NOTE: For use with T and TP style actuators. **Cannot be used for Switch Functions: 7103, 7203, 7303, 7403, 7107, 7207, 7307, 7407.**

704D02000 Sealing Boot

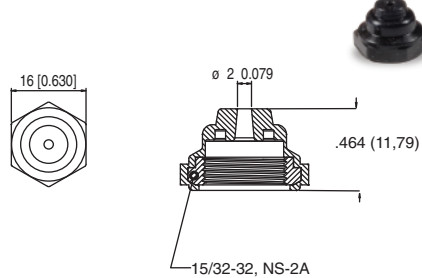

NOTE: For use with T, TP and T2P style actuators. **Cannot be used for Switch Functions: 7103, 7203, 7303, 7403, 7107, 7207, 7307, and 7407.**



Dimensions are shown: Inches (mm)
Specifications and dimensions subject to change



Toggle



Military/Aerospace/Hi-REL MIL-S-83731 Toggle Switches

Features/Benefits

- Qualified to MIL-S-83731
- 50 μ inch selective gold contact plating
- Epoxy sealed terminals for process compatibility
- Rated for logic level to 5 amp resistive loads and 2 amp inductive loads
- Flame retardant housing material
- RoHS compliant and compatible

| Test Requirement | MIL-S-83731/9, 10, 13, 14, 15, 16 |
|---|--|
| 1. Strength of Terminal | 1 lb. – solder lug |
| 2. Strength of Actuating Lever Pivot and Stop | 10 lbs. & 8 lbs. throughout range |
| 3. Strength of Mounting Means | 15 lbs. in. torque on bushing |
| 4. Dielectric (Sea Level) Indication | 1000 VAC Group B, 750 VAC after electrical endurance. 500 μ A max. leakage |
| 5. Contact Voltage Drop | 2.5 millivolt initial, 5.0 millivolt after mechanical endurance @ 2-6 VDC 0.1 amp |
| 6. Temperature Rise | 50° C rise max. @ rated resistive load after endurance test |
| 7. Short Circuit | 10 operations carry 100 amps resistive load @ lowest DC volts |
| 8. Mechanical Life | 20K operations at specified high and low temperatures |
| 9. Electrical Endurance | 10K operations at specified high and low temperatures |
| 10. Overload | 50 operations @ 150% of rated resistive load |
| 11. Electrical Endurance at Sea Level | 10K operations resistive load @ room temperature 10K operations inductive load @ room temperature 10K operations lamp load @ room temperature Performed on different test samples |
| 12. Vibration | Method 204 of MIL-STD-202, test condition A .06 D. A. or 10 G's 10-500 Hz, 10 usec. max. chatter |
| 13. Shock | Fuse-method 213 or MIL-STD-202, 10 usec. max. chatter |
| 14. Salt Spray Test Upon Completion | 48 hours – method 101 of MIL-STD-202, test condition B 10 operations resistive load (toggle sealed switches only) |
| 15. Moisture Resistance Test Upon Completion | Method 106 of MIL-STD-202 100 VDC potential between current carrying parts and panel |
| 16. Sand & Dust | Method 110 of MIL-STD-202, test condition B 6 hours @ 23°C 2.5K operations mechanical life (toggle sealed switches only) |
| 17. Explosion | MIL-STD-202 method 109, maximum rated DC inductive load (toggle sealed switches only) |
| 18. Sealing | Toggle seal – 5 operations under 0.5 inches of H ₂ O above top of bushing |
| 19. A.) Toggle Seal B.) Bushing Seal | (Toggle sealed switches only) (Panel sealed switches only) |
| 20. Temperature Operation | Mechanical life, –25°C to +71°C |
| 21. Life Low Cur. Level | No requirement |
| 22. Fungus | No requirement |
| 23. Intermediate Current | 20K operations, 35/40 milliamps @ 5 VDC resistive load @ +71°C |
| 24. Thermal Shock | Method 107 of MIL-STD-202 test condition A; 5 cycles @ –55°C/+85°C |

RATINGS

CURRENT RATINGS – HIGH LEVEL

| Current Capacity in Amperes – Per Pole | | |
|--|-----------------|----------------|
| 28V dc | 115V ac, 400 Hz | 125V ac, 60 Hz |
| Lamp Load | | |
| 1 | 1 | 1 |
| Resistive Load | | |
| 5 | 5 | 5 |
| Inductive Load | | |
| 2 | 2 | 2 |

CURRENT RATINGS – LOGIC LEVEL

| |
|---|
| 0.5 Volt – Amp (VA) Max. @ 28 V Max. (AC or DC) |
|---|

MATERIALS

CASE: Diallyl phthalate (DAP) (UL 94 V-0).
 BUSHING: Brass, nickel plated.
 HOUSING: Stainless steel.
 ACTUATOR: Brass, chrome plated.
 SWITCH SUPPORT: Brass, tin plated.
 TERMINALS: Gold over nickel over copper alloy.
 TERMINAL SEAL: Epoxy.
 CONTACTS: Gold over nickel over silver over brass.
 PANEL SEAL: Silicone rubber.
 MOUNTING HARDWARE: Two hexagon nut, brass with nickel plating; one lockwasher, steel with nickel plating; one locking ring, brass with nickel plating.

HOW TO ORDER: Complete part numbers for MIL-S-83731 TOGGLE SWITCHES are shown on pages F–18 through F–21.



Dimensions are shown: Inches (mm)
 Specifications and dimensions subject to change



Military/Aerospace/Hi-REL MIL-S-83731 Toggle Switches



| NO. POLES | MODEL NO. | SWITCH FUNCTION | | | CONNECTED TERMINALS | | | SCHEMATIC |
|--------------|--------------|-----------------|--------|--------|---------------------|--------|--------|-----------|
| | | POS. 1 | POS. 2 | POS. 3 | POS. 1 | POS. 2 | POS. 3 | |
| SP | M83731/9-211 | ON | OFF | ON | 2-3 | OPEN | 2-1 | SPDT |
| | M83731/9-231 | ON | NONE | ON | | | | |
| | M83731/9-261 | ON | NONE | MOM. | | | | |
| | M83731/9-271 | MOM. | OFF | MOM. | | | | |
| | M83731/9-311 | ON | OFF | MOM. | | | | |
| M83731/9-341 | NONE | ON | MOM. | N/A | 2-3 | 2-1 | | |

SPDT

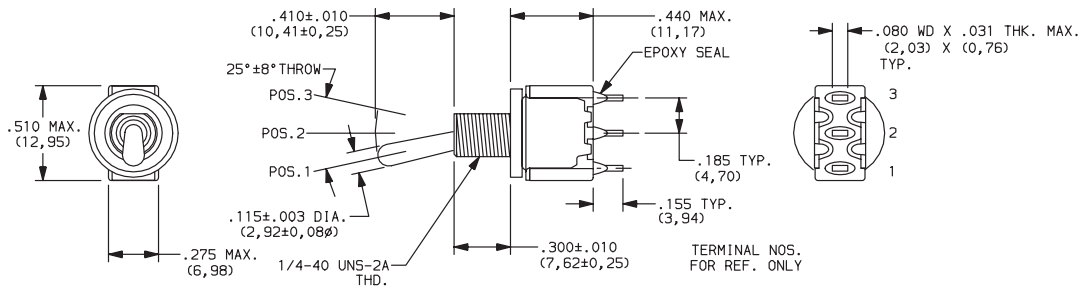

| NO. POLES | MODEL NO. | SWITCH FUNCTION | | | CONNECTED TERMINALS | | | SCHEMATIC |
|---------------|---------------|-----------------|--------|--------|---------------------|---------|---------|-----------|
| | | POS. 1 | POS. 2 | POS. 3 | POS. 1 | POS. 2 | POS. 3 | |
| DP | M83731/10-211 | ON | OFF | ON | 2-3,5-6 | OPEN | 2-1,5-4 | DPDT |
| | M83731/10-231 | ON | NONE | ON | | | | |
| | M83731/10-261 | ON | NONE | MOM. | | | | |
| | M83731/10-271 | MOM. | OFF | MOM. | | | | |
| | M83731/10-311 | ON | OFF | MOM. | | | | |
| | M83731/10-321 | ON | ON | ON | | | | |
| | M83731/10-331 | ON | ON | MOM. | | | | |
| | M83731/10-341 | NONE | ON | MOM. | | | | |
| M83731/10-351 | MOM. | ON | MOM. | N/A | 2-3,5-6 | 2-1,5-4 | | |

DPDT

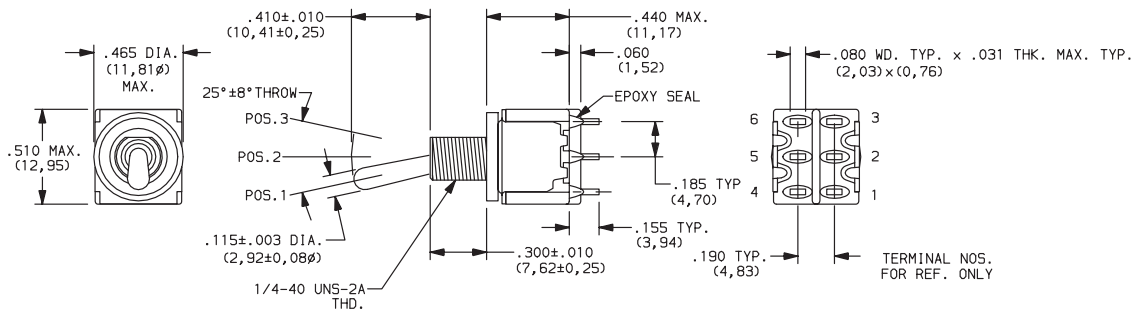

PANEL MOUNTING

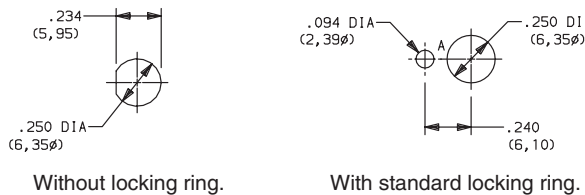

Dimensions are shown: Inches (mm)
Specifications and dimensions subject to change



Toggle



Military/Aerospace/Hi-REL MIL-S-83731 Toggle Switches



| NO. POLES | MODEL NO. | SWITCH FUNCTION | | | CONNECTED TERMINALS | | | SCHEMATIC |
|-----------|--------------|-----------------|--------|--------|---------------------|--------|--------|-----------|
| | | POS. 1 | POS. 2 | POS. 3 | POS. 1 | POS. 2 | POS. 3 | |
| | | | | | | | | |
| SP | M83731/9-212 | ON | OFF | ON | 2-3 | OPEN | 2-1 | SPDT |
| | M83731/9-232 | ON | NONE | ON | | | | |
| | M83731/9-262 | ON | NONE | MOM. | | | | |
| | M83731/9-272 | MOM. | OFF | MOM. | | | | |
| | M83731/9-312 | ON | OFF | MOM. | | | | |
| | M83731/9-342 | NONE | ON | MOM. | | | | |

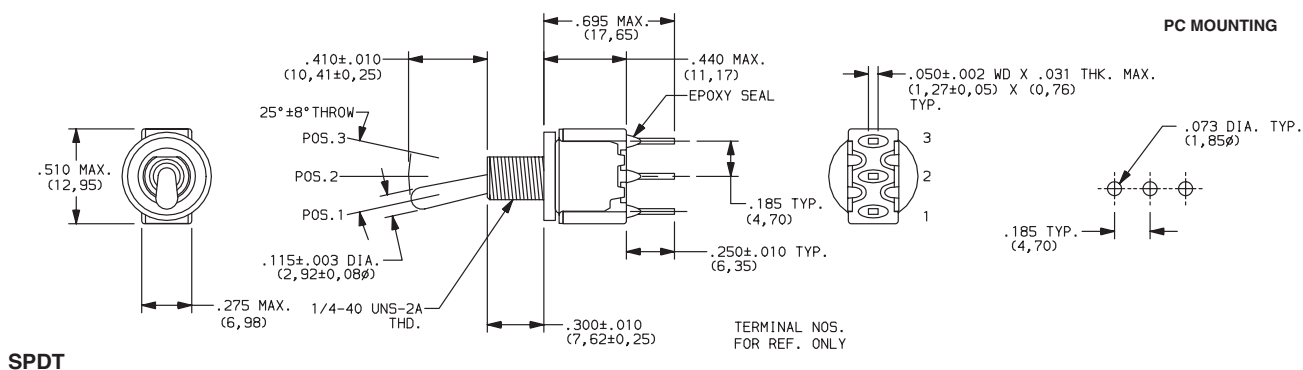

| NO. POLES | MODEL NO. | SWITCH FUNCTION | | | CONNECTED TERMINALS | | | SCHEMATIC |
|---------------|---------------|-----------------|--------|---------|---------------------|---------|---------|-----------|
| | | POS. 1 | POS. 2 | POS. 3 | POS. 1 | POS. 2 | POS. 3 | |
| | | | | | | | | |
| DP | M83731/10-212 | ON | OFF | ON | 2-3,5-6 | OPEN | 2-1,5-4 | DPDT |
| | M83731/10-232 | ON | NONE | ON | | | | |
| | M83731/10-262 | ON | NONE | MOM. | | | | |
| | M83731/10-272 | MOM. | OFF | MOM. | | | | |
| | M83731/10-312 | ON | OFF | MOM. | | | | |
| | M83731/10-322 | ON | ON | ON | | | | |
| | M83731/10-332 | ON | ON | MOM. | | | | |
| | M83731/10-342 | NONE | ON | MOM. | | | | |
| M83731/10-352 | MOM. | ON | MOM. | 2-3,5-6 | 2-3,5-4 | 2-1,5-4 | | |

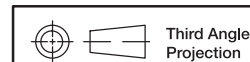
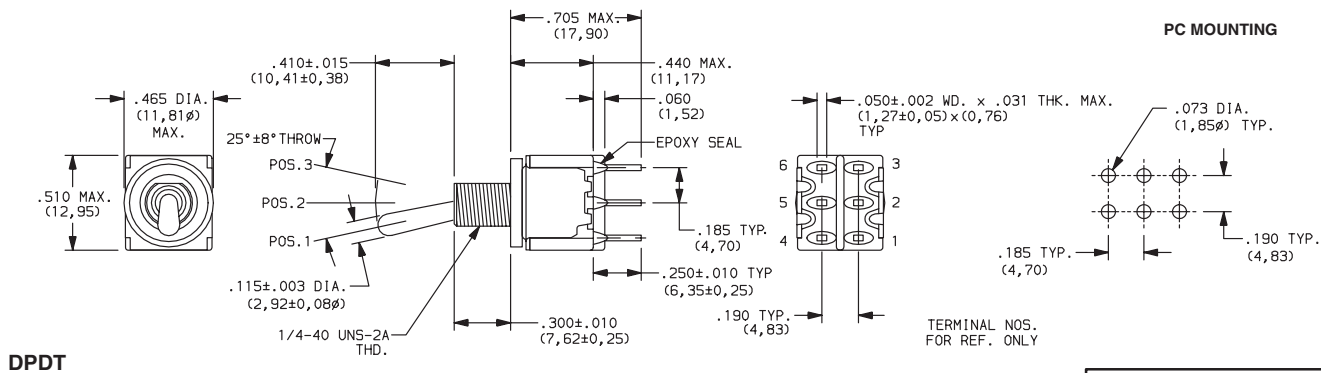

Dimensions are shown: Inches (mm)
Specifications and dimensions subject to change

www.ck-components.com



Military/Aerospace/Hi-REL MIL-S-83731 Toggle Switches

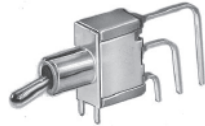

| NO. POLES | MODEL NO. | SWITCH FUNCTION | | | CONNECTED TERMINALS | | | SCHEMATIC |
|-----------|---------------|-----------------|--------|--------|---------------------|--------|--------|-----------|
| | | POS. 1 | POS. 2 | POS. 3 | POS. 1 | POS. 2 | POS. 3 | |
| SP | M83731/13-211 | ON | OFF | ON | 2-3 | OPEN | 2-1 | SPDT |
| | M83731/13-231 | ON | NONE | ON | | | | |
| | M83731/13-261 | ON | NONE | MOM. | | | | |
| | M83731/13-271 | MOM. | OFF | MOM. | | | | |
| | M83731/13-311 | ON | OFF | MOM. | | | | |
| | M83731/13-341 | NONE | ON | MOM. | N/A | 2-3 | 2-1 | |

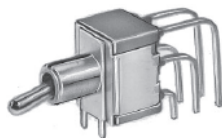
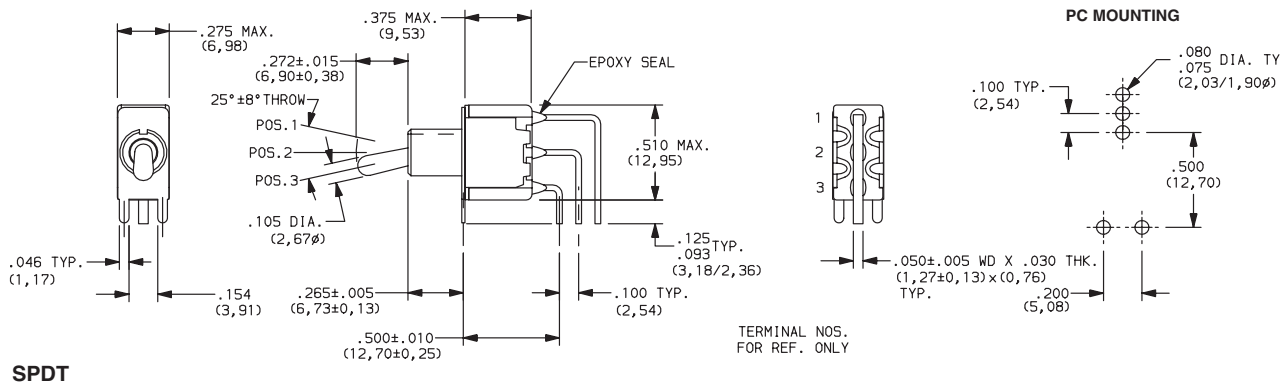

| NO. POLES | MODEL NO. | SWITCH FUNCTION | | | CONNECTED TERMINALS | | | SCHEMATIC |
|-----------|---------------|-----------------|--------|--------|---------------------|---------|---------|-----------|
| | | POS. 1 | POS. 2 | POS. 3 | POS. 1 | POS. 2 | POS. 3 | |
| DP | M83731/14-211 | ON | OFF | ON | 2-3,5-6 | OPEN | 2-1,5-4 | DPDT |
| | M83731/14-231 | ON | NONE | ON | | | | |
| | M83731/14-261 | ON | NONE | MOM. | | | | |
| | M83731/14-271 | MOM. | OFF | MOM. | | | | |
| | M83731/14-311 | ON | OFF | MOM. | | | | |
| | M83731/14-321 | ON | ON | ON | | | | |
| | M83731/14-331 | ON | ON | MOM. | | | | |
| | M83731/14-341 | NONE | ON | MOM. | | | | |
| | M83731/14-351 | MOM. | ON | MOM. | 2-3,5-6 | 2-3,5-4 | 2-1,5-4 | |

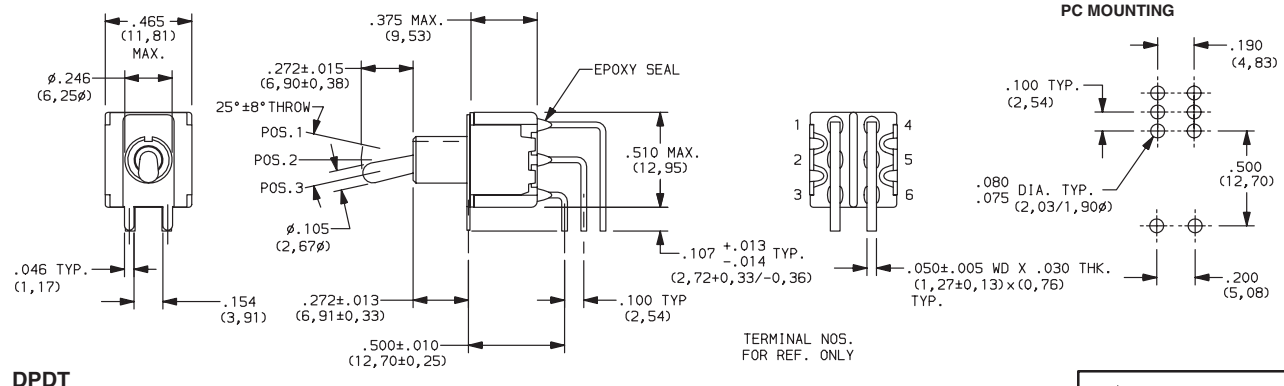

Toggle
F

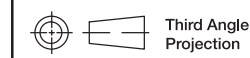

Dimensions are shown: Inches (mm)
Specifications and dimensions subject to change

Military/Aerospace/Hi-REL MIL-S-83731 Toggle Switches



| NO. POLES | MODEL NO. | SWITCH FUNCTION | | | CONNECTED TERMINALS | | | SCHEMATIC |
|-----------|---------------|-----------------|--------|--------|---------------------|--------|--------|-----------------------|
| | | POS. 1 | POS. 2 | POS. 3 | POS. 1 | POS. 2 | POS. 3 | |
| | | | | | | | | |
| SP | M83731/15-211 | ON | OFF | ON | 2-3 | OPEN | 2-1 | 2 (COMM) 1 ● 3 |
| | M83731/15-231 | ON | NONE | ON | | | | |
| | M83731/15-261 | ON | NONE | MOM. | | | | |
| | M83731/15-271 | MOM. | OFF | MOM. | | | | |
| | M83731/15-311 | ON | OFF | MOM. | | | | |
| | M83731/15-341 | NONE | ON | MOM. | | | | |

PC MOUNTING

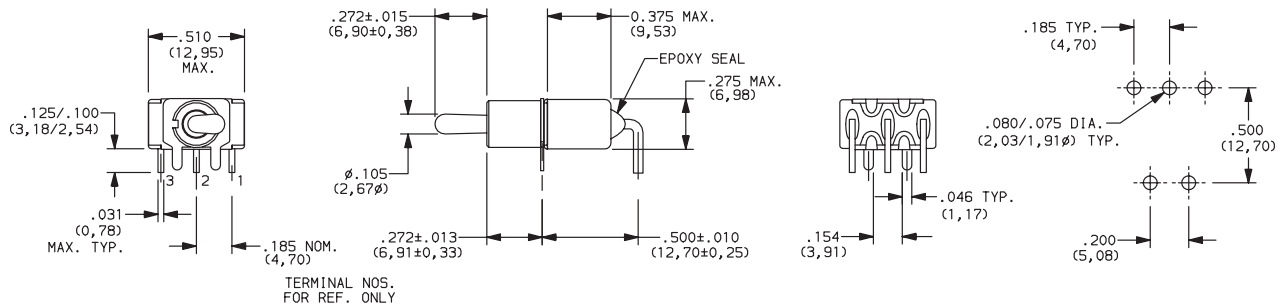

SPDT

| NO. POLES | MODEL NO. | SWITCH FUNCTION | | | CONNECTED TERMINALS | | | SCHEMATIC | | | |
|-----------|---------------|-----------------|--------|--------|---------------------|--------|---------|-----------------------|---------|---------|---------|
| | | POS. 1 | POS. 2 | POS. 3 | POS. 1 | POS. 2 | POS. 3 | | | | |
| | | | | | | | | | | | |
| DP | M83731/16-211 | ON | OFF | ON | 2-3,5-6 | OPEN | 2-1,5-4 | 2 (COMM) 1 ● 6 | | | |
| | M83731/16-231 | ON | NONE | ON | | | | | | | |
| | M83731/16-261 | ON | NONE | MOM. | | | | | | | |
| | M83731/16-271 | MOM. | OFF | MOM. | | | | | | | |
| | M83731/16-311 | ON | OFF | MOM. | | | | | | | |
| | M83731/16-321 | ON | ON | ON | | | | | | | |
| | M83731/16-331 | ON | ON | MOM. | | | | | | | |
| | M83731/16-341 | NONE | ON | MOM. | | | | | N/A | 2-3,5-6 | 2-1,5-4 |
| | M83731/16-351 | MOM. | ON | MOM. | | | | | 2-3,5-6 | 2-3,5-4 | 2-1,5-4 |

PC MOUNTING

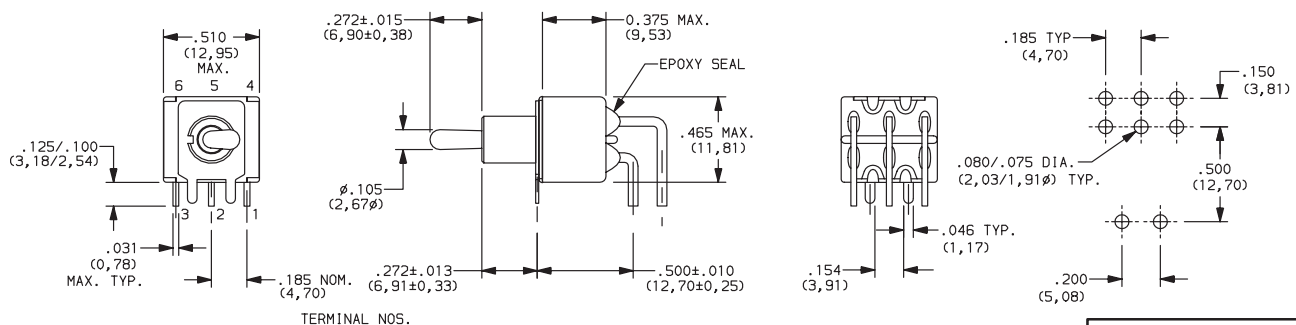

DPDT

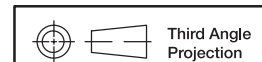

Dimensions are shown: Inches (mm)
Specifications and dimensions subject to change

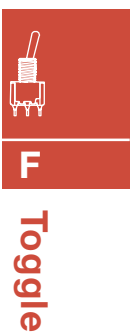

E Series Sealed Miniature Toggle Switches

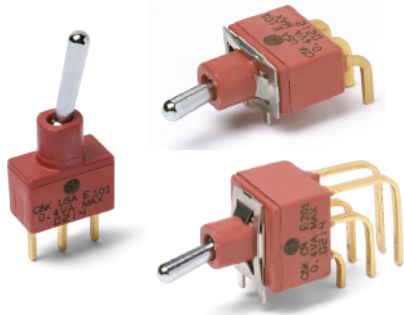

Features/Benefits

- Sealed against solder and cleaning process contaminants
- UL 94V-0 Nylon case and bushing
- Multi-positions
- ESD protection available
- RoHS compliant models available

Typical Applications

- Telecommunications
- Instrumentation
- Medical equipment



Specifications

CONTACT RATING: B contact material: 0.4 VA max. @ 20 V AC or DC max. Q contact material: E1XX & E2XX MODELS: 7.5 AMPS @ 125 V AC or 28 V DC; 3 AMPS @ 250 V AC. E3XX MODELS: 5 AMPS @ 125 V AC or 28 V DC; 2 AMPS @ 250 V AC. See page F-29 for additional ratings.

ELECTRICAL LIFE: E1XX and E2XX models: 40,000 make-and-break cycles at full load. E3XX models: 30,000 cycles.

CONTACT RESISTANCE: Below 10 mΩ typ. initial @ 2-4 V DC, 100 mA, for both silver and gold plated contacts.

INSULATION RESISTANCE: 10⁹ Ω min.

ELECTROSTATIC DISCHARGE (ESD) OPTION: F1 conductive bushing only. Dissipates up to 20,000 V DC from actuator to ground.

DIELECTRIC STRENGTH: 1000 Vrms min. @ sea level.

OPERATING TEMPERATURE: -30°C to 85°C.

SOLDERABILITY: Per MIL-STD-202F method 208D, or EIA RS-186E method 9 (1 hour steam aging).

DEGREE OF PROTECTION: IP57; Protection against harmful dust deposit, full-scale voltage protection, temporary immersion.

Materials

CASE & BUSHING: Glass filled nylon 6/6, flame retardant, heat stabilized (UL 94V-0). F1 conductive bushing option is impregnated with carbon fibers.

ACTUATOR: Brass, chrome plated with internal o-ring seal standard.

SWITCH SUPPORT: Brass or steel, matte-tin plated.

SWITCH SUPPORT RETAINER: Stainless steel.

CONTACTS & TERMINALS: B contact material: Copper alloy, with gold plate over nickel plate. Q contact material: Copper alloy, silver plated. See page F-29 for additional contact materials.

TERMINAL SEAL: Epoxy.

HARDWARE: Nut & Locking ring: Brass, nickel plated. Lockwasher: Steel, nickel plated.

NOTE: Any models supplied with P, S, R, Q, B or G contact material are RoHS compliant and compatible.

NOTE: Specifications and materials listed above are for switches with standard options. For information on specific and custom switches, consult Customer Service Center.

Build-A-Switch

To order, simply select desired option from each category and place in the appropriate box. Available options are shown and described on pages F-23 thru F-29. For additional options not shown in catalog, consult our Customer Service Center. All models are process sealed to withstand machine soldering temperatures and pressure wash cleaning methods.

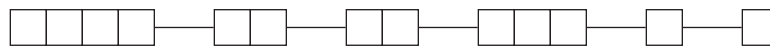

Switch Function

- E101** SP, On-None-On
- E103** SP, On-Off-On
- E105** SP, Mom.-Off-Mom.
- E107** SP, On-Off-Mom.
- E108** SP, On-None-Mom.
- E201** DP, On-None-On
- E203** DP, On-Off-On
- E205** DP, Mom.-Off-Mom.
- E207** DP, On-Off-Mom.
- E208** DP, On-None-Mom.
- E211** DP, On-On-On
- E213** DP, On-On-Mom.
- E215** DP, Mom.-On-Mom.
- **E301** 3P, On-None-On

Actuator

- M** .300" high
- S** .500" high
- L3** Plastic, .940" high

Bushing

- D1** .250" high
- *F1** Conductive, .250" high
- D9** .280" high
- **Y** Threaded, .350" high

Terminations

- A** Right angle, PC thru-hole
- AV2** Vertical right angle, PC thru-hole
- C** PC Thru-hole
- V3** .460" high, V-bracket
- Z** Solder lug
- A3** Right angle, PC thru-hole
- AV3** Vertical right angle, PC thru-hole
- V6** .460" high, V-bracket
- V9** 1.150" high, V-bracket
- V31** .460" high, snap-in V-bracket
- V61** .460" high, snap-in V-bracket
- W** .750" long, wire wrap
- Z3** Quick connect

Contact Material

- B** Gold
- P** Gold, matte-tin
- Q** Silver
- S** Silver, matte-tin
- G** Gold over silver
- R** Gold over silver, matte-tin

Seal

- E** Epoxy



Toggle

* F1 available with SP and DP versions only, please see page F-19

** Y threaded bushing available for 1 & 2 pole only



Dimensions are shown: Inches (mm)
Specifications and dimensions subject to change

E Series Sealed Miniature Toggle Switches

SWITCH FUNCTION

| NO. POLES | MODEL NO. | SWITCH FUNCTION | | | CONNECTED TERMINALS | | | SCHEMATIC |
|--|---------------|-----------------|--------|--------|---------------------|--------|---------|-----------|
| | | POS. 1 | POS. 2 | POS. 3 | POS. 1 | POS. 2 | POS. 3 | |
| SP | E101 | ON | NONE | ON | 2-3 | N/A | 2-1 | |
| | E103 | ON | OFF | ON | 2-3 | OPEN | 2-1 | |
| | E105 | MOM. | OFF | MOM. | | | | |
| | E107 | ON | OFF | MOM. | | | | |
| | E108 | ON | NONE | MOM. | | | | |
| <p>SPDT</p> <p>Part number shown: E101SD1CBE</p> <p>Terminal Numbers For Reference Only</p> | | | | | | | | |
| DP | E201 | ON | NONE | ON | 2-3,5-6 | N/A | 2-1,5-4 | |
| | E203 | ON | OFF | ON | 2-3,5-6 | OPEN | 2-1,5-4 | |
| | E205 | MOM. | OFF | MOM. | | | | |
| | E207 | ON | OFF | MOM. | | | | |
| | E208 | ON | NONE | MOM. | | | | |
| | E211** | ON | ON | ON | | | | |
| | E213** | ON | ON | MOM. | | | | |
| E215** | MOM. | ON | MOM. | | | | | |
| <p>DPDT</p> <p>Part number shown: E201SD1CBE</p> <p>Terminal Numbers For Reference Only</p> | | | | | | | | |

MOM. = Momentary

** Wiring for 3-way switch, see Section N.

All models with all options when ordered with G,R, Q or S contact material except with F1 conductive bushing.

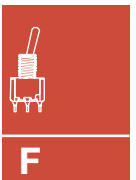

Toggle

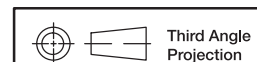

Dimensions are shown: Inches (mm)
Specifications and dimensions subject to change

E Series Sealed Miniature Toggle Switches

SWITCH FUNCTION

| NO. POLES | MODEL NO. | SWITCH FUNCTION | | | CONNECTED TERMINALS | | | SCHEMATIC |
|-----------|-------------|-----------------|--------|--------|---------------------|--------|-------------|-----------|
| | | POS. 1 | POS. 2 | POS. 3 | POS. 1 | POS. 2 | POS. 3 | |
| 3P | E301 | ON | NONE | ON | 2-3,5-6,8-9 | N/A | 2-1,5-4,8-7 | |
| 3PDT | | | | | | | | |

MOM. = Momentary

** Wiring for 3-way switch, see Section N.

All models with all options when ordered with G, R, Q or S contact material except with F1 conductive bushing.

ACTUATOR

M .300" HIGH

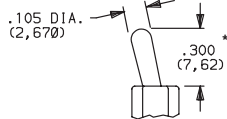

Standard when ordered with A, A3, AV2, AV3, V2-V61 terminations. Finish: Chrome.

S .500" HIGH

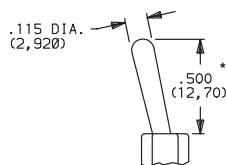

Standard when ordered with C, Z, Z3, W & W4 terminations. Finish: Chrome

L3 PLASTIC, .940" HIGH

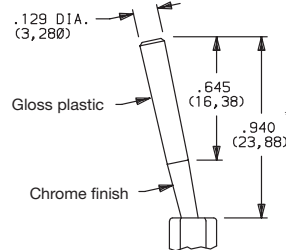

| OPTION CODE | L3 ACTUATOR COLOR |
|-------------|-------------------|
| 2 | BLACK |

Other colors available, consult Customer Service Center. No color choice required for S & M actuators.

* Actuators shown with standard D1 bushing. Subtract .030 (0,76) for D9 bushing. Subtract .100 (2,54) for Y bushing.

BUSHING

D1 .250" HIGH, UNTHREADED

F1 ESD CONDUCTIVE BUSHING, .250" HIGH, UNTHREADED

F1 bushing is not UL approved

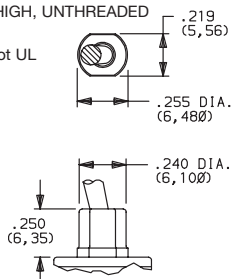

ESD protection depends on proper grounding of switch support bracket. F1 conductive bushing option is impregnated with carbon fibers; dissipates electrostatic discharge (ESD) up to 20,000 V from actuator to ground.

Available with M & S actuator options and A, A3, AV2, AV3, V3-V61 termination options.

D9 .280" HIGH, UNTHREADED

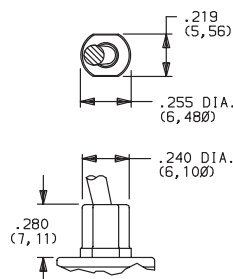

E3XX models not available with D9 bushing.

NOTE: Internal o-ring actuator seal standard for all bushing options.

Y THREADED, INSULATED, .350" HIGH WITH KEYWAY

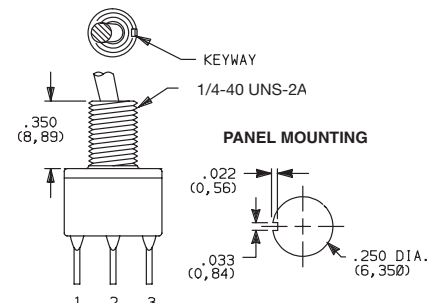

Available only with C, Z, Z3, & W terminations. Available for 1&2 pole only.

Hardware: One dress nut part number 299D01201, one hex nut part number 540400201 and lockwasher part number 700303202 supplied standard.

Will withstand 4 in.-lbs. of torque with no distortion.



Dimensions are shown: Inches (mm)
Specifications and dimensions subject to change

www.ck-components.com

E Series Sealed Miniature Toggle Switches

TERMINATIONS

Z SOLDER LUG

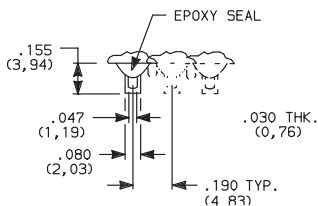

Not available with F1 conductive bushing or P, R or S contact material.

SPDT thru 3PDT

C PC THRU-HOLE

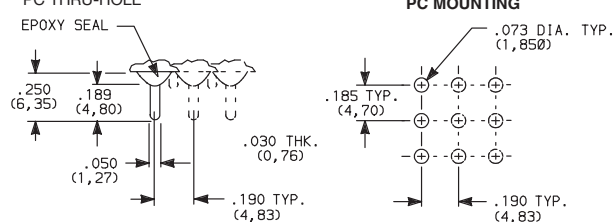

Not available with F1 conductive bushing.

SPDT thru 3PDT

Z3 QUICK CONNECT

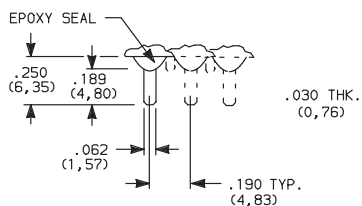

Not available with F1 conductive bushing or P, R or S contact material. Mating quick connector available; order part number 530100000, page F-16.

SPDT thru 3PDT

A RIGHT ANGLE, PC THRU-HOLE

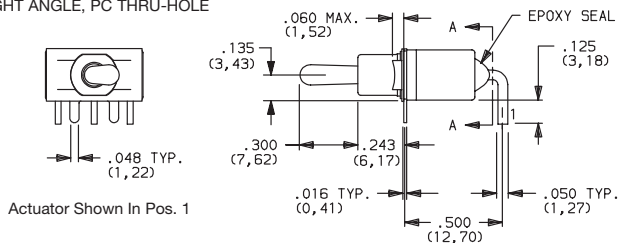

Actuator Shown In Pos. 1

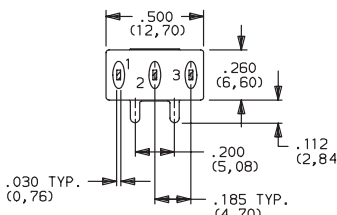

Terminal Nos. For Reference Only

PC MOUNTING

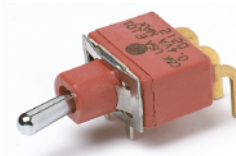
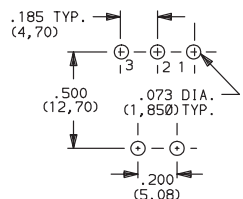

E101MD1ABE
Horizontal Actuation
SPDT

A3 RIGHT ANGLE, SNAP-IN, PC THRU-HOLE

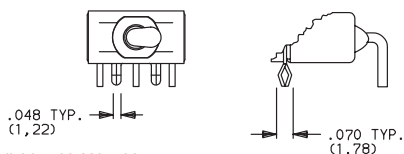

Not available with Y bushing.
Terminal bend radii and lead-in manufacturing option.

A RIGHT ANGLE, PC THRU-HOLE

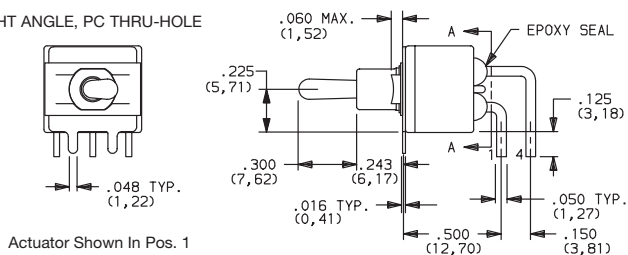

Actuator Shown In Pos. 1

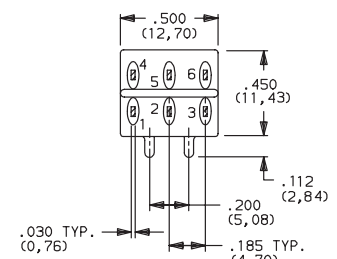

Terminal Nos. For Reference Only

PC MOUNTING

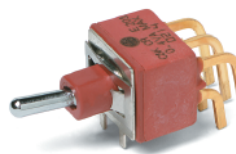
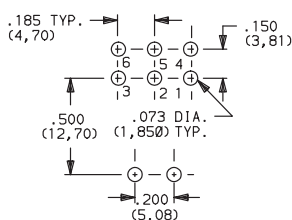

E201MD1ABE
Horizontal Actuation
DPDT

A3 RIGHT ANGLE, SNAP-IN, PC THRU-HOLE

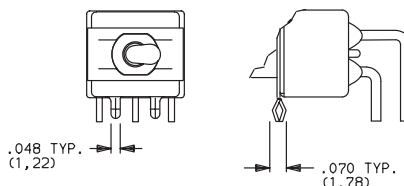

Not available with Y bushing.
Terminal bend radii and lead-in manufacturing option.



Third Angle
Projection

Dimensions are shown: Inches (mm)
Specifications and dimensions subject to change

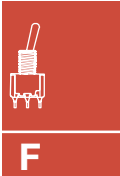

Toggle

E Series Sealed Miniature Toggle Switches

TERMINATIONS

A RIGHT ANGLE, PC THRU-HOLE

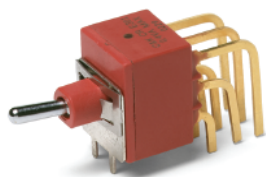

E301MD1ABE
Horizontal Actuation
3PDT

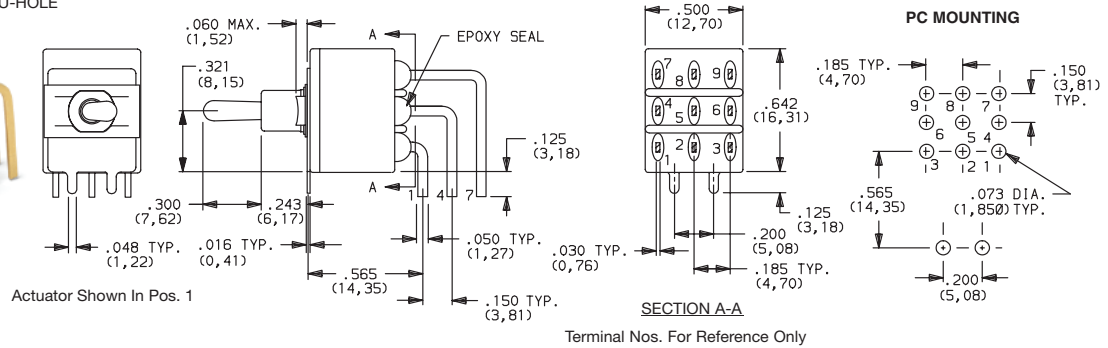

Not available with D9 & Y bushings.
Terminal bend radii and lead-in manufacturing option.

AV2 VERTICAL RIGHT ANGLE, PC THRU-HOLE, .150" PITCH

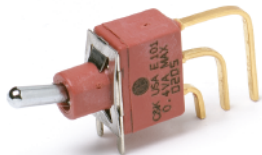

E101MD1AV2BE
Vertical Actuation
SPDT

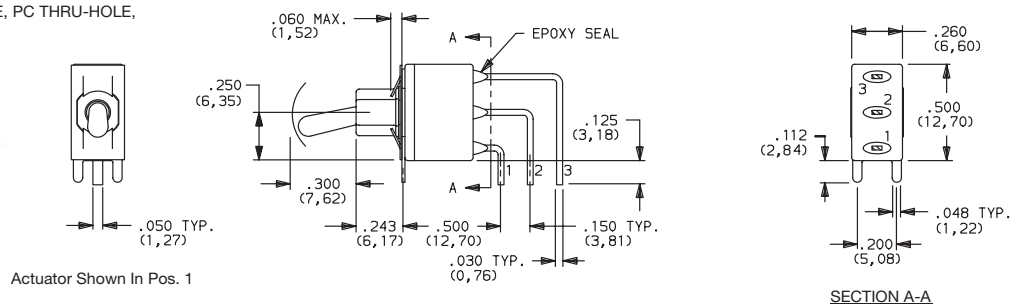

AV3 VERTICAL RIGHT ANGLE, SNAP-IN, PC THRU-HOLE, .150" PITCH

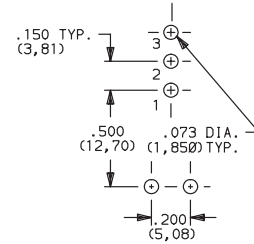
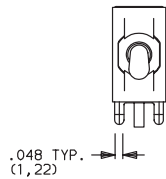

Not available with Y bushing.
Terminal bend radii and lead-in manufacturing option.

AV2 VERTICAL RIGHT ANGLE, PC THRU-HOLE, .150" PITCH

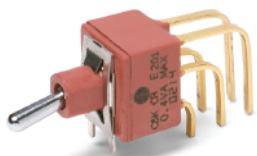

E201MD1AV2BE
Vertical Actuation
DPDT

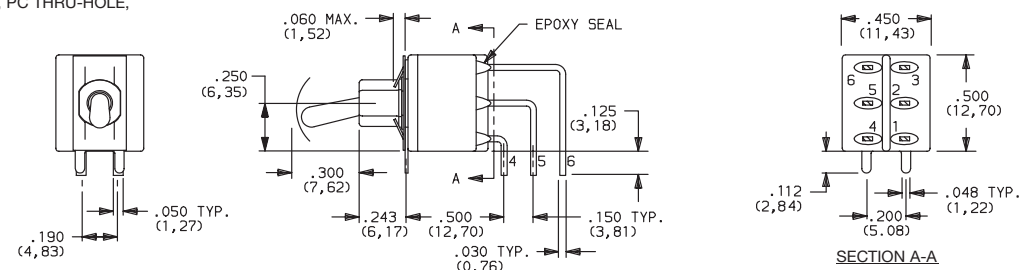

A3 VERTICAL RIGHT ANGLE, SNAP-IN, PC THRU-HOLE, .150" PITCH

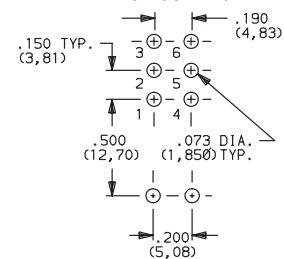
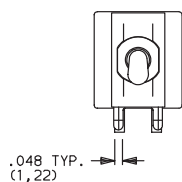

Not available with Y bushing.
Terminal bend radii and lead-in manufacturing option.

Toggle

F

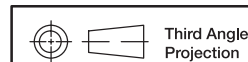

Dimensions are shown: Inches (mm)
Specifications and dimensions subject to change



E Series Sealed Miniature Toggle Switches

TERMINATIONS

AV2 VERTICAL RIGHT ANGLE, PC THRU-HOLE,
.150" PITCH

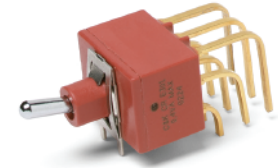
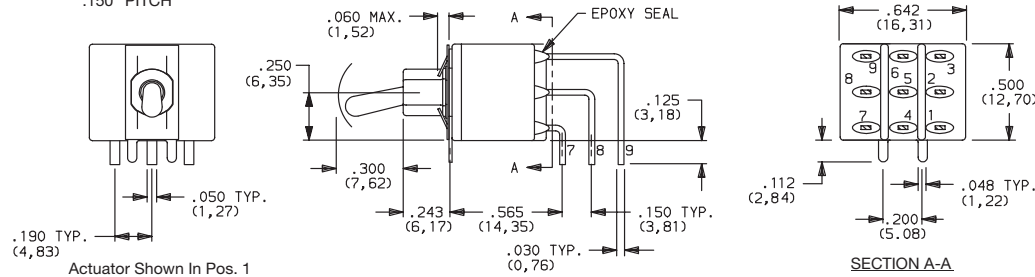

E301MD1AV2BE
Vertical Actuation
3PDT

AV3 VERTICAL RIGHT ANGLE, SNAP-IN, PC THRU-HOLE
.150" PITCH

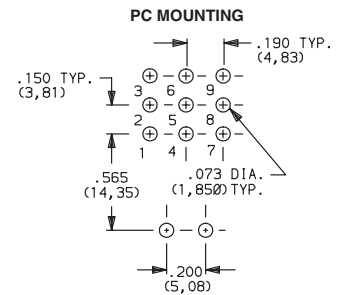

Not available with D9 & Y bushings.
Terminal bend radii and lead-in manufacturing option.

V6 VERTICAL MOUNT, V-BRACKET

V61 VERTICAL MOUNT, V-BRACKET, SNAP-IN

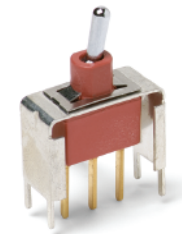
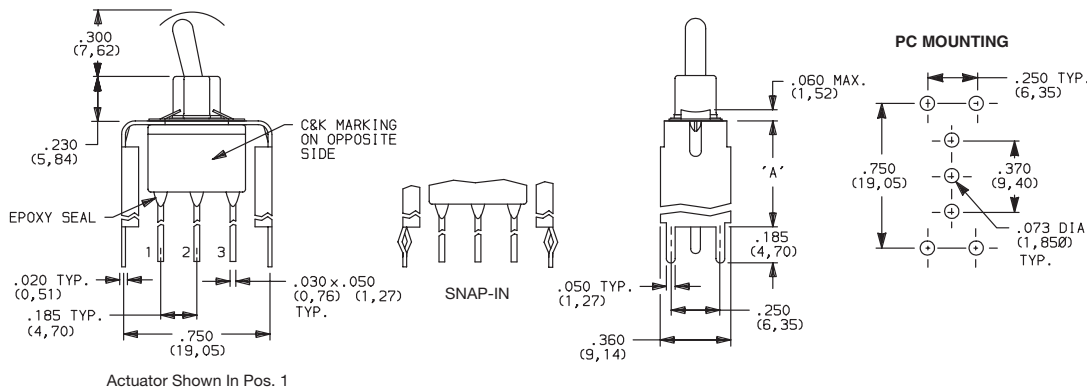

E101MD1_BE
SPDT

| OPTION CODE | DIM 'A' |
|----------------|--------------|
| V6, V61 | .460 (11,68) |

Not available with Y bushing.

V6 VERTICAL MOUNT, V-BRACKET

V61 VERTICAL MOUNT, V-BRACKET, SNAP-IN

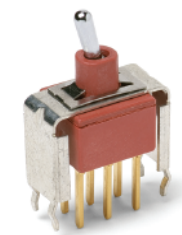
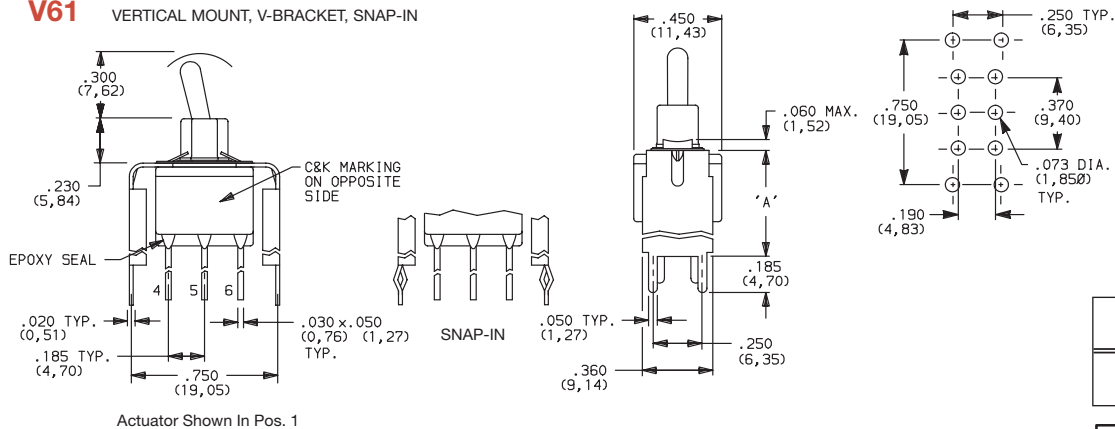

E201MD1_BE
DPDT

| OPTION CODE | DIM 'A' |
|----------------|--------------|
| V6, V61 | .460 (11,68) |

Not available with Y bushing.

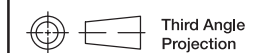

Dimensions are shown: Inches (mm)
Specifications and dimensions subject to change

www.ck-components.com



E Series Sealed Miniature Toggle Switches

TERMINATIONS

V3, V9 VERTICAL MOUNT, V-BRACKET

V31 VERTICAL MOUNT, V-BRACKET, SNAP-IN



E101MD1_BE
SPDT

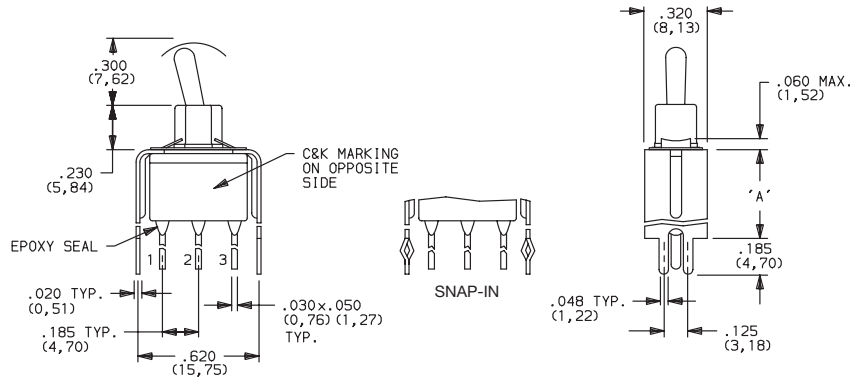

Actuator Shown In Pos. 1

Not available with Y bushing.

PC MOUNTING

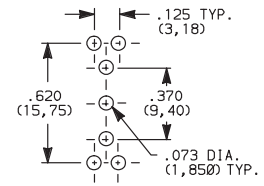

| OPTION CODE | DIM 'A' |
|----------------|---------------|
| V3, V31 | .460 (11,68) |
| V9 | 1.150 (29,21) |

V3, V9 VERTICAL MOUNT, V-BRACKET

V31 VERTICAL MOUNT, V-BRACKET, SNAP-IN



E201MD1_BE
DPDT

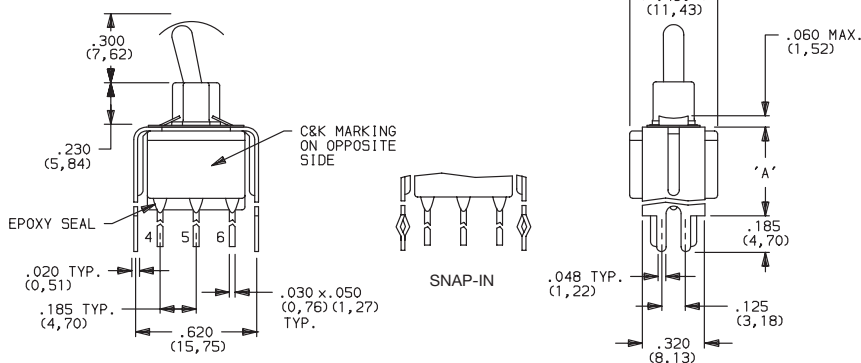

Actuator Shown In Pos. 1

Not available with Y bushing.

PC MOUNTING

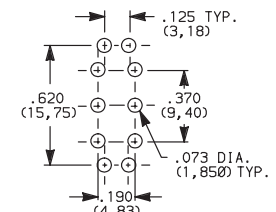

| OPTION CODE | DIM 'A' |
|----------------|---------------|
| V3, V31 | .460 (11,68) |
| V9 | 1.150 (29,21) |

V9 VERTICAL MOUNT, V-BRACKET

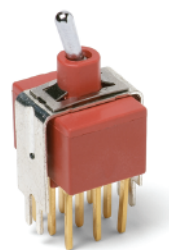

E301MD1_BE
3PDT

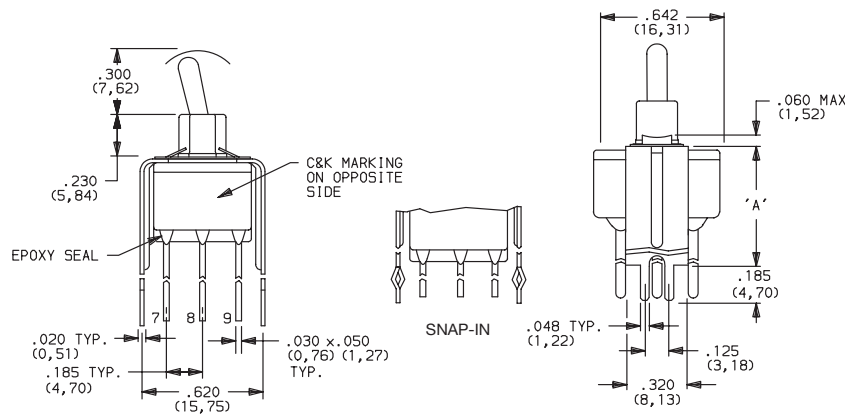

Actuator Shown In Pos. 1

Not available with D9 & Y bushings.

PC MOUNTING

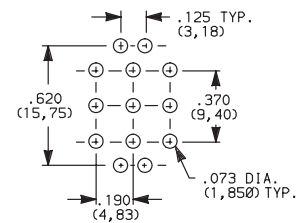

| OPTION CODE | DIM 'A' |
|-------------|---------------|
| V9 | 1.150 (29,21) |

Toggle

F

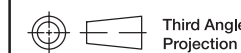

Third Angle Projection
Dimensions are shown: Inches (mm)
Specifications and dimensions subject to change

E Series Sealed Miniature Toggle Switches

CONTACT MATERIAL



| OPTION CODE | CONTACT MATERIAL | TERMINAL PLATING | RATINGS | |
|-------------|------------------------------------|------------------------|-----------------------------------|---|
| B | GOLD ¹ | GOLD ¹ | LOW LEVEL/ DRY CIRCUIT | 0.4 VA MAX. @ 20 V AC OR DC MAX. |
| P | | MATTE-TIN ⁶ | | |
| Q | SILVER ^{4,5} | SILVER ⁵ | POWER | E1XX & E2XX MODELS: 7.5 AMPS @ 125 V AC OR 28 V DC; 3 AMPS @ 250 V AC. E3XX MODELS: 5 AMPS @ 125 V AC OR 28 V DC; 2 AMPS @ 250 V AC. |
| S | | MATTE-TIN ⁶ | | |
| G | GOLD OVER SILVER ^{2,3} | GOLD ³ | LOW LEVEL/DRY CIRCUIT OR POWER | E1XX AND E2XX MODELS: 0.4 VA MAX @20 V AC OR DC MAX. OR 7.5 AMPS @125 V AC OR 28 V DC; 3 AMPS @ 250 V AC. DC E3XX MODELS: 0.4 VA MAX. @ 20 V AC OR DC MAX. OR 5 AMPS @ 125 V AC OR 28 V DC; 2 AMPS @ 250 V AC. |
| R | | MATTE-TIN ⁶ | | |

* Note: See Technical Data section of this catalog for RoHS compliant and compatible definitions and specifications.

¹ CONTACTS & TERMINALS: Copper alloy, with gold plate over nickel plate.

² END CONTACTS: Coin silver, with gold plate over nickel plate.

³ CENTER CONTACTS & ALL TERMINALS: Copper alloy, with gold plate over nickel plate.

⁴ END CONTACTS: Coin silver, silver plated.

⁵ CENTER CONTACT & ALL TERMINALS: Copper alloy, with gold flash over silver plate. Or copper alloy, silver plated.

⁶ TERMINALS: Copper alloy, with matte-tin over nickel plate.

NOTE: Any models supplied with P, S, R, Q, B or G contact material are RoHS compliant.

All models **CAUS** with all options when ordered with S, R, G, or Q contact material except with F1 conductive bushing.

B contact material standard with all terminations.

P, S & R contact materials not available with Z & Z3 terminations.

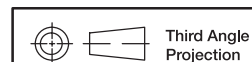

Third Angle
Projection

Dimensions are shown: Inches (mm)
Specifications and dimensions subject to change

www.ck-components.com



Toggle

ET Series Sealed Subminiature Toggle Switches

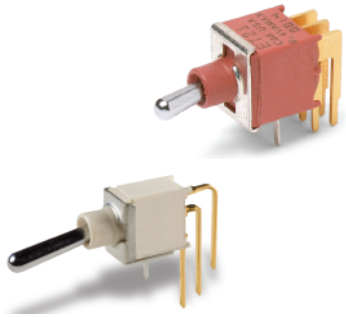

Features/Benefits

- Sealed against solder and cleaning process contaminants
- ESD protection available
- Thru-hole and surface mount models
- Compact size and small footprint save PCB space
- RoHS compliant models available

Typical Applications

- Hand-held telecommunications
- Instrumentation
- Medical equipment

Specifications

CONTACT RATING: B contact material: 0.4 VA max. @ 20 V AC or DC max. See page F-35 for additional ratings.

ELECTRICAL LIFE: ETX1 models: 60,000 make-and-break cycles at full load. All other models: 30,000 cycles.

CONTACT RESISTANCE: Below 20 m Ω typ. initial @ 2-4 V DC, 100 mA, for both silver and gold plated contacts.

INSULATION RESISTANCE: 10⁹ Ω min.

ELECTROSTATIC DISCHARGE (ESD) RESISTANT OPTION: M3 & S3 insulating actuator only: 9,000 V DC min. @ sea level, actuator to terminals. F1 conductive bushing only: Dissipates up to 20,000 V DC from actuator to ground. M3 & S3 actuator and F1 bushing options are not recommended for use together.

DIELECTRIC STRENGTH: 1000 Vrms min. @ sea level.

OPERATING TEMPERATURE: -30°C to 85°C.

SOLDERABILITY: Per MIL-STD-202F method 208D, or EIA RS-186E method 9 (1 hour steam aging).

DEGREE OF PROTECTION: IP57; Protection against harmful dust deposit, full-scale voltage protection, temporary immersion.

PACKAGING: Surface mount switches are shipped in tape and reel packaging, see page F-36 for drawings and reel information.

Materials

CASE & BUSHING: Glass filled nylon 6/6, flame retardant, heat stabilized (UL 94V-0) or glass filled 4/6 nylon, flame retardant, heat stabilized (UL 94V-0). F1 conductive bushing option is impregnated with carbon fibers.

ACTUATOR: M3 & S3 anti-static actuator: Nylon 4/6, black standard (UL 94V-0). All other actuators: Brass, chrome plated. Internal o-ring seal standard with all actuators.

SWITCH SUPPORT: Brass, tin plated.

CONTACTS & TERMINALS: B contact material: Copper alloy, with gold plate over nickel plate. Q contact material: Copper alloy, silver plated. See F-35 for additional contact materials.

TERMINAL SEAL: Epoxy.

NOTE: Any models supplied with Q, B, G, P or R contact material are RoHS compliant and compatible.

NOTE: Specifications and materials listed above are for switches with standard options. For information on specific and custom switches, consult Customer Service Center.

Build-A-Switch

To order, simply select desired option from each category and place in the appropriate box. Available options are shown and described on pages F-31 thru F-36. For additional options not shown in catalog, consult our Customer Service Center. All models are process sealed to withstand machine soldering temperatures and pressure wash cleaning methods.

Switch Function

- ET01 SP, On-None-On
- ET02 SPST, Off-None-On
- ET03 SP, On-Off-On
- ET05 SP, Mom.-Off-Mom.
- ET07 SP, On-Off-Mom.
- ET08 SP, On-None-Mom.
- ET21 DP, On-None-On
- ET23 DP, On-Off-On
- ET24 DP, On-On-On
- ET25 DP, Mom.-Off-Mom.
- ET27 DP, On-Off-Mom.
- ET28 DP, On-None-Mom.

Actuator

- M .240" high
- M3 Plastic, anti-static, .240" high
- S .400" high
- L .320" high
- S1 .540" high

Bushing

- D1 .177" High, Unthreaded
- F1 .177" high, unthreaded, ESD conductive

Terminations

- A Right angle, PC thru-hole
- AV Vertical right angle, PC thru-hole
- C PC Thru-hole
- SA Right angle, surface mount
- SA1 Right angle, surface mount rear-facing
- V3 Vertical mount, V-bracket
- AV3 Vertical right angle, snap-in, PC thru-hole
- V31 Vertical mount, V-bracket, snap-in
- W Wire wrap

Contact Material

- B Gold
- P Gold, matte tin
- Q Silver
- S Silver/matte-tin
- G Gold over silver
- R Gold over silver, matte-tin

Seal

- E Epoxy

Plastic Actuator Color

- NONE No actuator color
- 2 Black
- 1 White



Toggle



Dimensions are shown: Inches (mm)
Specifications and dimensions subject to change

ET Series Sealed Subminiature Toggle Switches

SWITCH FUNCTION

| NO. POLES | MODEL NO. | SWITCH FUNCTION | | | CONNECTED TERMINALS | | | SCHEMATIC |
|--|---------------|-----------------|--------|--------|---------------------|---------|---------|-----------|
| | | POS. 1 | POS. 2 | POS. 3 | POS. 1 | POS. 2 | POS. 3 | |
| SP | ET01 | ON | NONE | ON | 2-3 | N/A | 2-1 | |
| | ET03 | ON | OFF | ON | 2-3 | OPEN | 2-1 | |
| | ET05 | MOM. | OFF | MOM. | | | | |
| | ET07 | ON | OFF | MOM. | | | | |
| | ET08 | ON | NONE | MOM. | 2-3 | N/A | 2-1 | |
| | ET02 | OFF | NONE | ON | OPEN | N/A | 3-1 | |
| SPDT <p>Part number shown: ET01MD1CBE ET02 Models: Omit terminal 2</p> | | | | | | | | |
| DP | ET21 | ON | NONE | ON | 2-3,5-6 | N/A | 2-1,5-4 | |
| | ET23 | ON | OFF | ON | 2-3,5-6 | OPEN | 2-1,5-4 | |
| | ET25 | MOM. | OFF | MOM. | | | | |
| | ET27 | ON | OFF | MOM. | | | | |
| | ET28 | ON | NONE | MOM. | 2-3,5-6 | N/A | 2-1,5-4 | |
| | ET24** | ON | ON | ON | 2-3,5-6 | 2-3,5-4 | 2-1,5-4 | |
| DPDT <p>Part number shown: ET21MD1CBE</p> | | | | | | | | |

MOM. = Momentary

** Wiring for 3-way switch, see Section N.

All models with all options (except M3 actuator) when ordered with G, L, R or Q contact material except with F1 conductive bushing.



Toggle

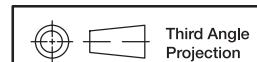

Third Angle
Projection

Dimensions are shown: Inches (mm)
Specifications and dimensions subject to change

ET Series Sealed Subminiature Toggle Switches

ACTUATOR

M .240" HIGH

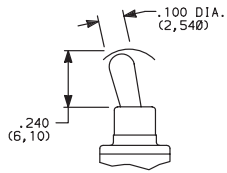

Standard with A, AV, V3 & V31 terminations.

M3 PLASTIC, ANTISTATIC,
.240" HIGH

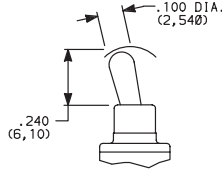

Material: Nylon 4/6 (UL 94V-0), black standard.
Static resistance: 9,000 V DC min. @ sea level,
actuator to terminals. Not available with F1
conductive bushing option. Not UL approved.

S .400" HIGH

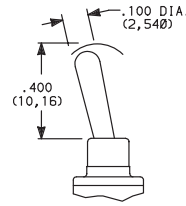

Standard with C or W terminations.

L .320" HIGH

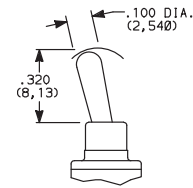

S1 .540" HIGH

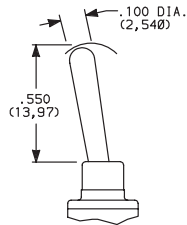

| OPTION CODE | PLASTIC ACTUATOR COLOR |
|-------------|------------------------|
| (NONE) | BLACK (M3 & S3 only) |
| 1 | WHITE (M3 & S3 only) |

NOTE: All actuators have chrome finish (except M3 & S3).

BUSHING

D1 .177" HIGH, UNTHREADED

F1 ESD, CONDUCTIVE BUSHING
UNTHREADED, .177" HIGH

F1 bushing is not UL approved

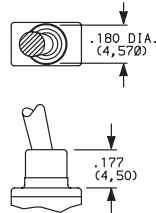

NOTE: ESD protection depends on proper grounding of switch support bracket. F1 conductive bushing option is impregnated with carbon fibers; dissipates electrostatic discharge (ESD) up to 20,000 V from actuator to ground. Available with all metal actuator options and A, AV, AV3, V3 and V31 termination options only. Internal actuator o-ring seal standard.

TERMINATIONS

C PC THRU-HOLE

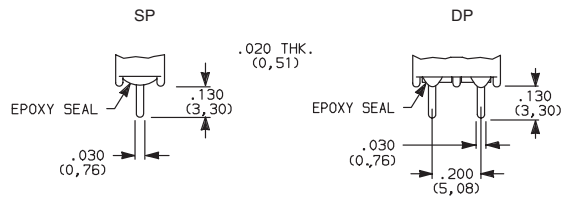

PC MOUNTING

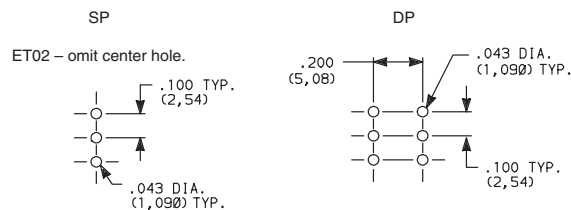

SP and DP

Not available with F1 conductive bushing.

W WIRE WRAP

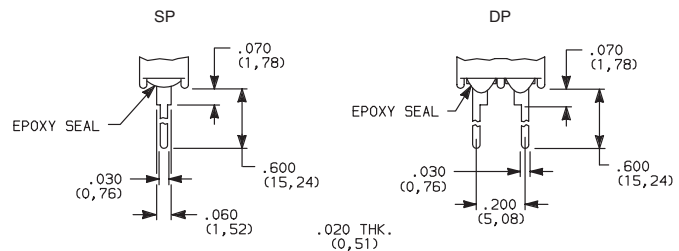

SP and DP

Not available with F1 conductive bushing.



Dimensions are shown: Inches (mm)
Specifications and dimensions subject to change

www.ck-components.com



Toggle



ET Series Sealed Subminiature Toggle Switches

TERMINATIONS

A RIGHT ANGLE, PC THRU-HOLE

ET01MD1ABE
Horizontal Actuation
SPDT

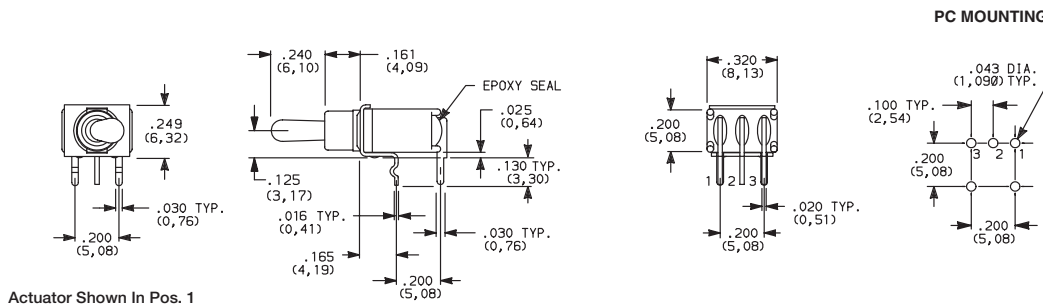

Not available with ET02 model.

A RIGHT ANGLE, PC THRU-HOLE

ET21MD1ABE
Horizontal Actuation
DPDT

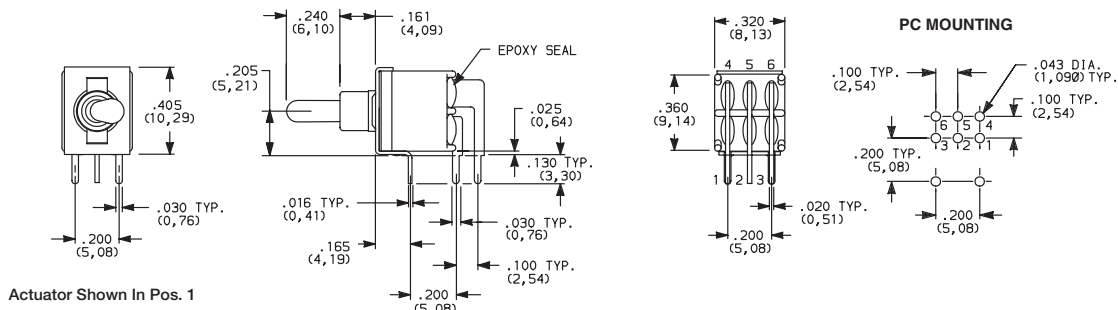

AV VERTICAL RIGHT ANGLE, PC THRU-HOLE

ET01MD1AVBE
Vertical Actuation
SPDT

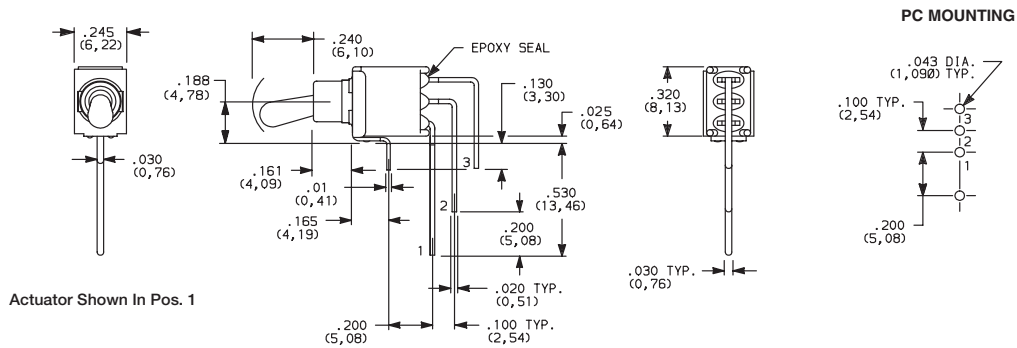

ET02 - omit terminal 2.

NOTE: Terminal bend radii and lead-in manufacturing option.

AV VERTICAL RIGHT ANGLE, PC THRU-HOLE

ET21MD1AVBE
Vertical Actuation
DPDT

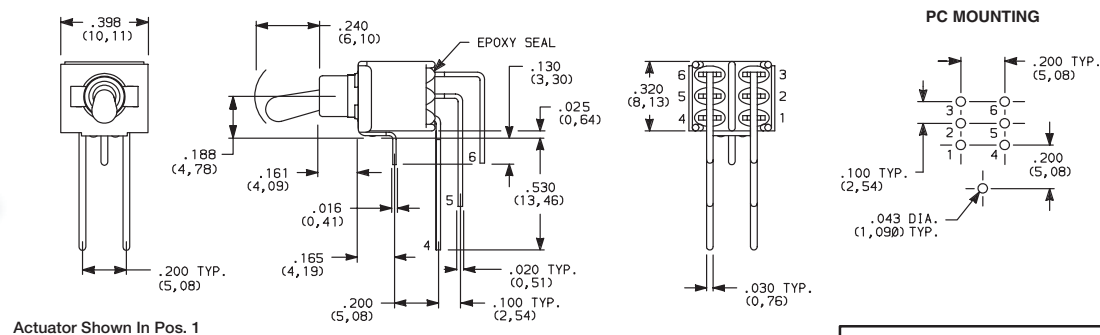

NOTE: Terminal bend radii and lead-in manufacturing option.

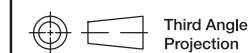

Third Angle
Projection



Dimensions are shown: Inches (mm)
Specifications and dimensions subject to change



F

Toggle

ET Series Sealed Subminiature Toggle Switches

TERMINATIONS

AV3 VERTICAL RIGHT ANGLE, SNAP-IN, PC THRU-HOLE

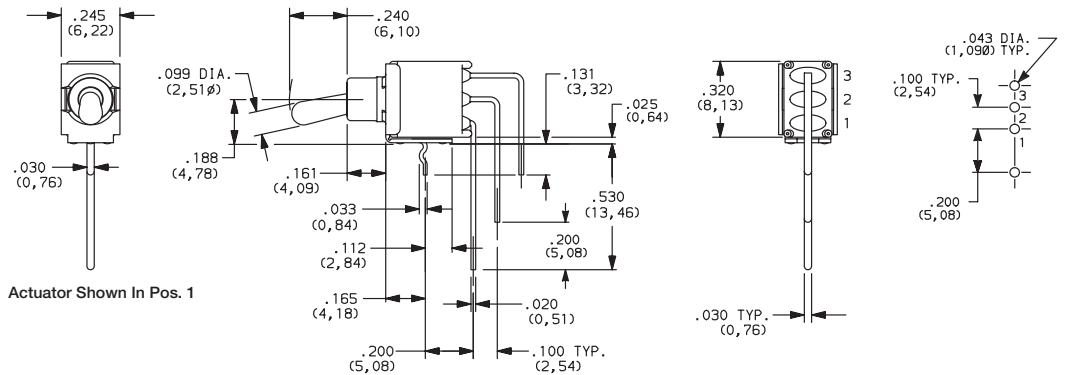

SA RIGHT ANGLE, SURFACE MOUNT

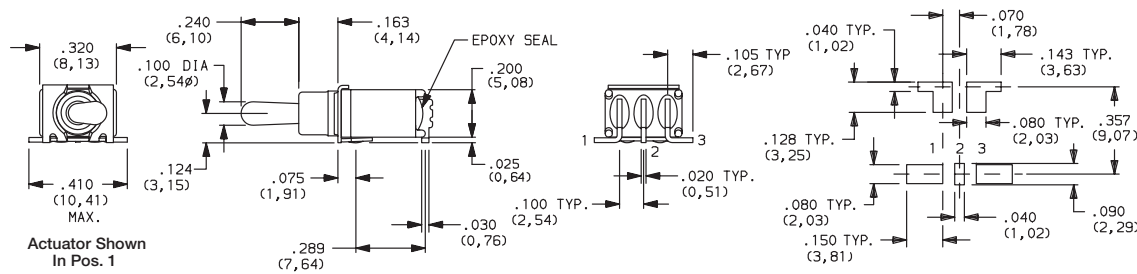

Not available with S and S1 actuators. Standard with tape & reel packaging. See page F-36.

SA1 RIGHT ANGLE, SURFACE MOUNT

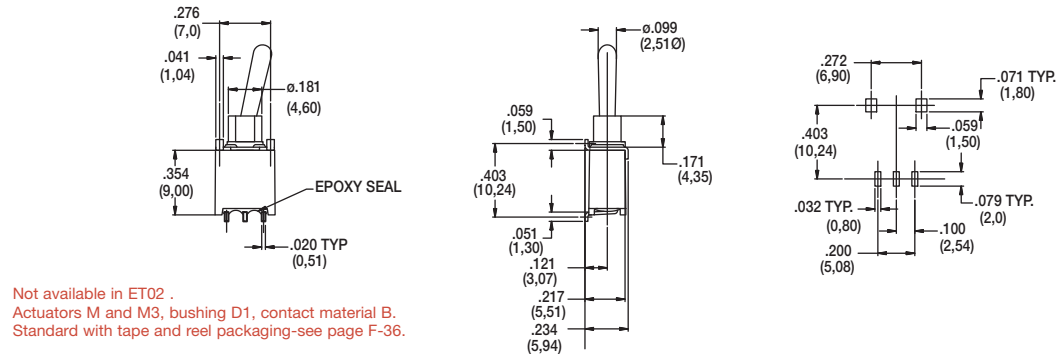

Not available in ET02.
Actuators M and M3, bushing D1, contact material B.
Standard with tape and reel packaging-see page F-36.

V3 VERTICAL MOUNT, V-BRACKET

V31 VERTICAL MOUNT, V-BRACKET, SNAP-IN

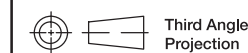
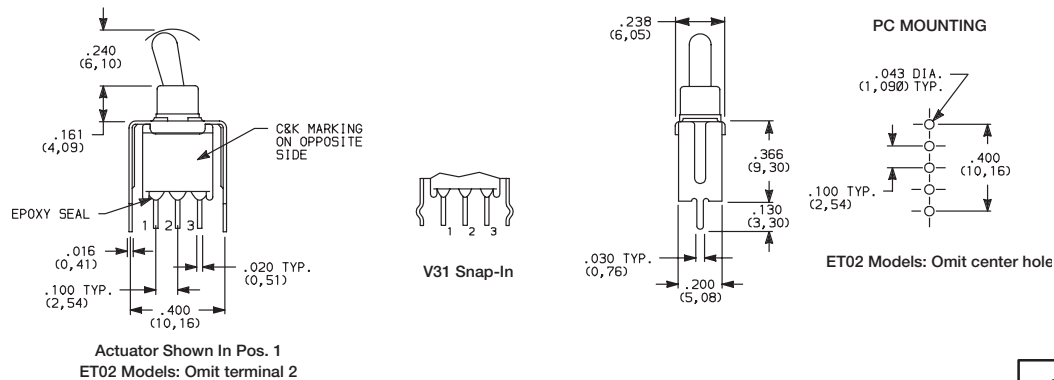

Dimensions are shown: Inches (mm)
Specifications and dimensions subject to change

www.ck-components.com



Toggle
F



ET Series Sealed Subminiature Toggle Switches

TERMINATIONS

V3 VERTICAL MOUNT, V-BRACKET

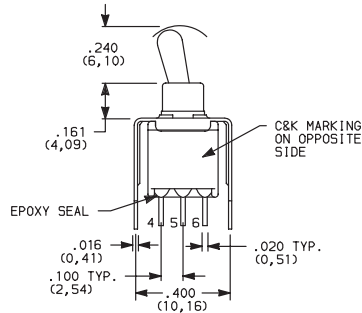

Actuator Shown In Pos. 1

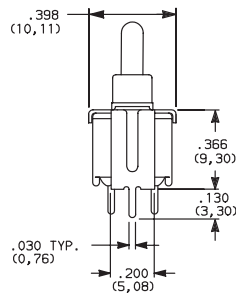

PC MOUNTING

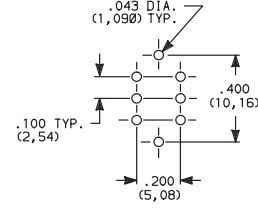

ET21MD1V3BE
DPDT

CONTACT MATERIAL

| OPTION CODE | CONTACT MATERIAL | TERMINAL PLATING | RATINGS | |
|-------------|---------------------------------|------------------------|--------------------------------|--|
| B | GOLD ¹ | GOLD ¹ | LOW LEVEL/DRY CIRCUIT | 0.4 VA MAX. @ 20 V AC OR DC MAX. |
| P | | MATTE-TIN ⁶ | | |
| Q | SILVER ^{4,5} | SILVER ⁵ | POWER | ETX1 MODELS: 3 AMPS @ 120 V AC OR 28 V DC ALL OTHER MODELS: 2 AMPS @ 120 V AC OR 28 V DC |
| S | | MATTE-TIN ⁶ | | |
| G | GOLD OVER SILVER ^{2,3} | GOLD ³ | LOW LEVEL/DRY CIRCUIT OR POWER | ETX1 MODELS: 0.4 VA MAX. @ 20 V AC OR DC MAX. OR 3 AMPS @ 120 V AC OR 28 V DC ALL OTHER MODELS: 0.4 VA MAX. @ 20 V AC OR DC MAX. OR 2 AMPS @ 120 V AC OR 28 V DC |
| R | | MATTE-TIN ⁶ | | |

* Note: See Technical Data section of this catalog for RoHS compliant and compatible definitions and specifications.

¹ CONTACTS & TERMINALS: Copper alloy, with gold plate over nickel plate.

² END CONTACTS: Coin silver, with gold plate over nickel plate.

³ CENTER CONTACTS & ALL TERMINALS: Copper alloy, with gold plate over nickel plate.

⁴ END CONTACTS: Coin silver, silver plated.

⁵ CENTER CONTACT & ALL TERMINALS: Copper alloy, silver plated.

⁶ TERMINALS: Copper alloy, with matte tin over nickel plate.

NOTE: Any models supplied with Q, B, G, P or R contact material are RoHS compliant.

All models  with all options (except M3 actuator) when ordered with G, L, R or Q contact material except with F1 conductive bushing.

SEAL

E EPOXY SEAL

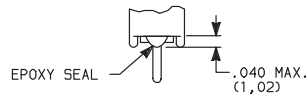

AVAILABLE HARDWARE

Cap

PART NO.

706201000 WHITE
706202000 BLACK
706203000 RED

Material: Vinyl
Finish: Matte

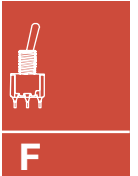
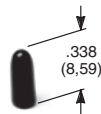

F

Toggle

NOTE: Other colors available, consult Customer Service Center.



Third Angle
Projection

Dimensions are shown: Inches (mm)
Specifications and dimensions subject to change

C&K

ET Series Sealed Subminiature Toggle Switches

TAPE & REEL

For part number ET01M3D1SAPE

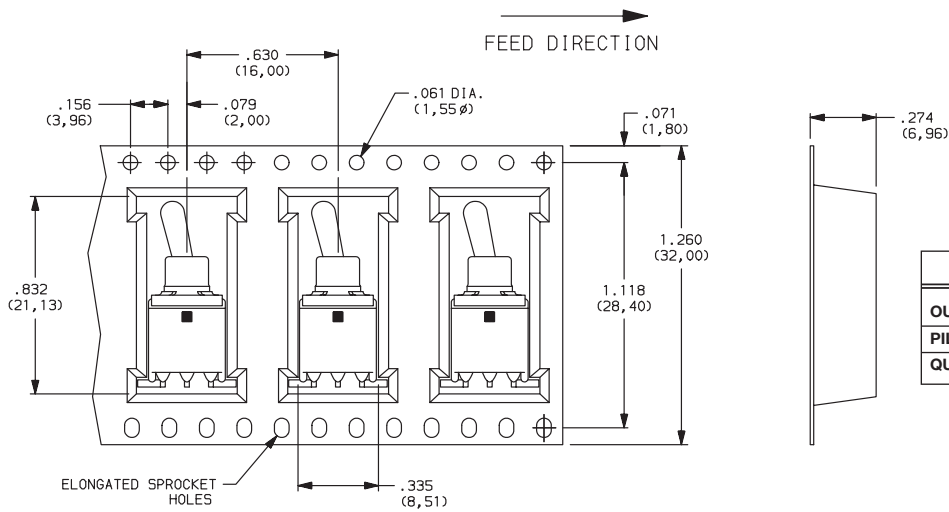

For part number ET01M3D1SA1BE

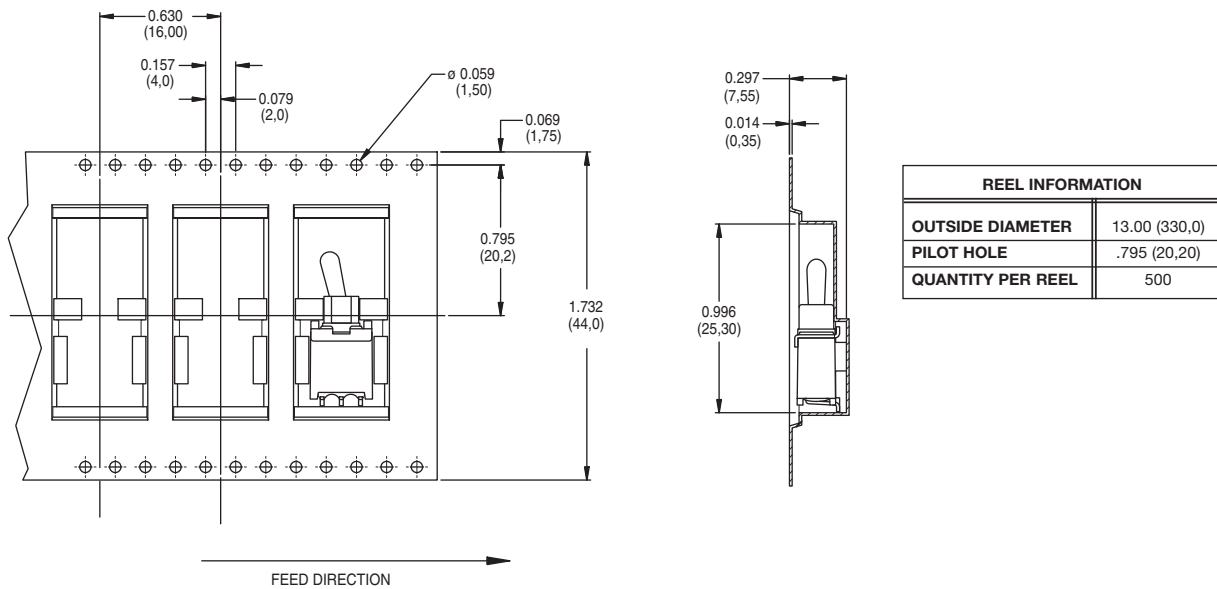

Toggle

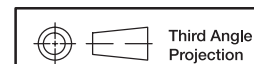

Dimensions are shown: Inches (mm)
Specifications and dimensions subject to change

T Series Subminiature Toggle Switches

Features/Benefits

- Compact size—small footprint
- Single and double pole models
- PC and panel mount options available
- RoHS compliant models available

Typical Applications

- Hand-held telecommunications
- Instrumentation
- Medical equipment

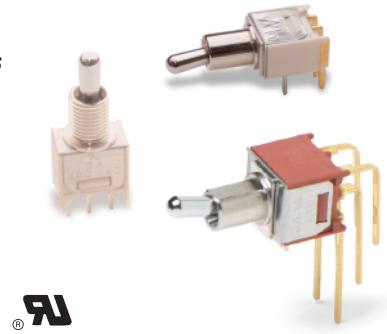

Specifications

CONTACT RATING: B contact material: 0.4 VA max. @ 20 V AC or DC max. Q contact material (TX01 models): 3 AMPS @ 120 V AC or 28 V DC. All other models: 2 AMPS @ 120 V AC or 28 V DC. See page F-42 for additional ratings.

ELECTRICAL LIFE: TX01 models: 60,000 make-and-break cycles at full load. All other models: 30,000 cycles.

CONTACT RESISTANCE: Below 20 m Ω typ. initial @ 2-4 V DC, 100 mA, for both silver and gold plated contacts.

INSULATION RESISTANCE: 10⁹ Ω min.

DIELECTRIC STRENGTH: 1000 Vrms min. @ sea level.

OPERATING TEMPERATURE: -30°C to 85°C.

SOLDERABILITY: Per MIL-STD-202F method 208D, or EIA RS-186E method 9 (1 hour steam aging).

NOTE: Any models supplied with P, R, Q, B or G contact material are RoHS compliant and compatible.

NOTE: Specifications and materials listed above are for switches with standard options. For information on specific and custom switches, consult Customer Service Center.

Materials

CASE: Glass filled nylon 6/6, flame retardant, heat stabilized or diallyl phthalate (DAP), (UL 94V-0) or glass filled nylon 4/6, flame retardant, heat stabilized.

ACTUATOR: Brass, chrome plated.

BUSHING: Brass, nickel plated.

HOUSING: Stainless steel.

SWITCH SUPPORT: Brass, matte-tin plated.

END CONTACTS: B contact material: Copper alloy, with gold plate over nickel plate. Q contact material: Coin silver, silver plated. See above for additional contact materials.

CENTER CONTACTS & TERMINALS: B contact material: Copper alloy, with gold plate over nickel plate. Q contact material: Copper alloy, silver plated. See page F-42 for additional contact materials.

TERMINAL SEAL: Epoxy.

HARDWARE: Nut & Locking Ring: Brass, nickel plated.

Lockwasher: Steel, nickel plated. Additional hardware available separately, see Section N.

Build-A-Switch

To order, simply select desired option from each category and place in the appropriate box. Available options are shown and described on pages F-38 thru F-42. For additional options not shown in catalog, consult Customer Service Center. All models have epoxy terminal seal and are compatible with all "bottom-wash" PCB cleaning methods.

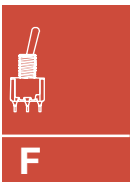
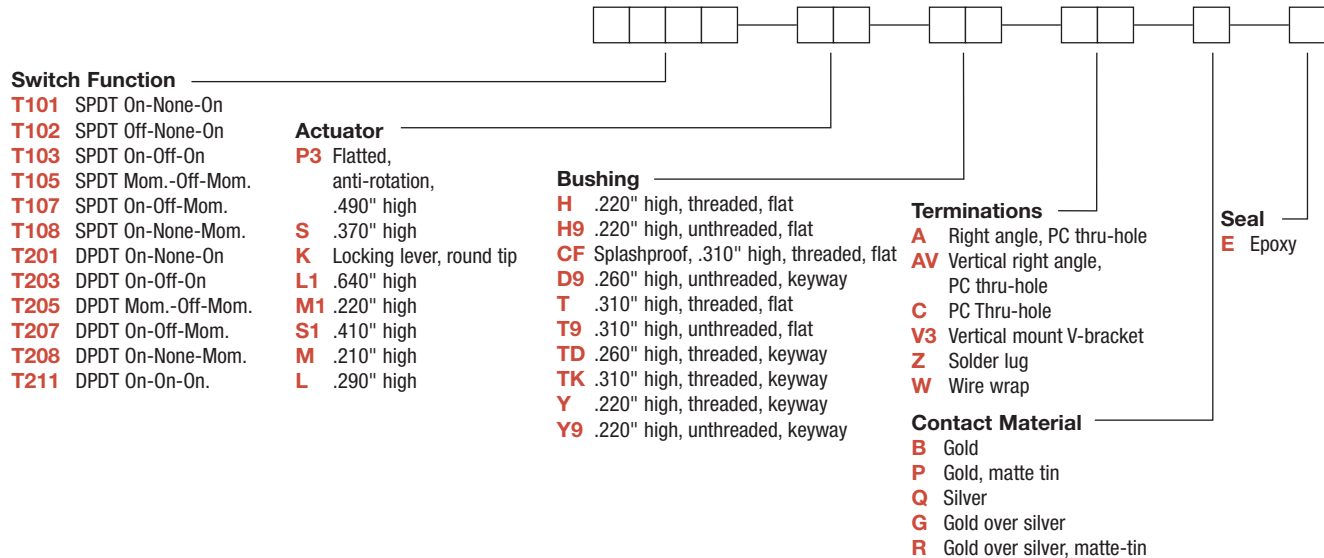

Toggle



Dimensions are shown: Inches (mm)
Specifications and dimensions subject to change

T Series Subminiature Toggle Switches

SWITCH FUNCTION

| NO. POLES | MODEL NO. | SWITCH FUNCTION | | | CONNECTED TERMINALS | | | SCHEMATIC |
|-----------|-------------|-----------------|--------|--------|---------------------|--------|--------|-----------|
| | | POS. 1 | POS. 2 | POS. 3 | POS. 1 | POS. 2 | POS. 3 | |
| SP | T101 | ON | NONE | ON | 2-3 | N/A | 2-1 | |
| | T103 | ON | OFF | ON | 2-3 | OPEN | 2-1 | |
| | T105 | MOM. | OFF | MOM. | | | | |
| | T107 | ON | OFF | MOM. | | | | |
| | T108 | ON | NONE | MOM. | 2-3 | N/A | 2-1 | |
| | T102 | OFF | NONE | ON | OPEN | N/A | 3-1 | |

SPDT

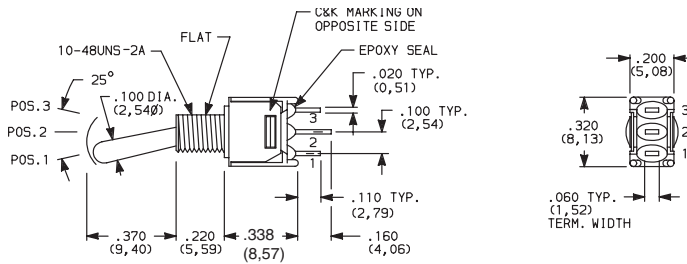

Part number shown: T101SHZQE

| NO. POLES | MODEL NO. | SWITCH FUNCTION | | | CONNECTED TERMINALS | | | SCHEMATIC |
|-----------|--------------|-----------------|--------|--------|---------------------|---------|---------|-----------|
| | | POS. 1 | POS. 2 | POS. 3 | POS. 1 | POS. 2 | POS. 3 | |
| DP | T201 | ON | NONE | ON | 2-3,5-6 | N/A | 2-1,5-4 | |
| | T203 | ON | OFF | ON | 2-3,5-6 | OPEN | 2-1,5-4 | |
| | T205 | MOM. | OFF | MOM. | | | | |
| | T208 | ON | NONE | MOM. | 2-3,5-6 | N/A | 2-1,5-4 | |
| | T211* | ON | ON | ON | 2-3,5-6 | 2-3,5-4 | 2-1,5-4 | |

DPDT

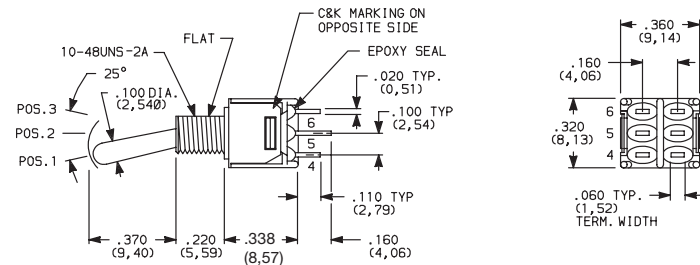

Part number shown: T201SHZQE

Terminal Nos.
For Reference Only

MOM. = Momentary
* Wiring for 3-way switch refer to page N-10

All models with all options when ordered with G, L, R or Q contact material.

Toggle

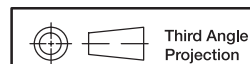

Dimensions are shown: Inches (mm)
Specifications and dimensions subject to change

T Series Subminiature Toggle Switches

ACTUATOR

M .210" HIGH

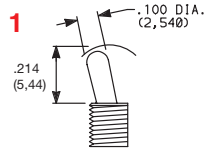

Standard with A, AV or V3 terminations.

S .370" HIGH

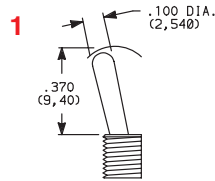

Standard with Z, C or W terminations.

M1 .220" HIGH
(with "T" bushing)

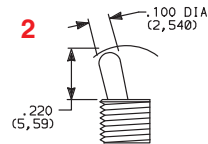

S1 .410" HIGH
(with "T" bushing)

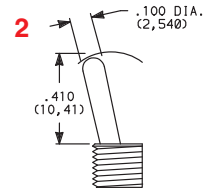

L .290" HIGH

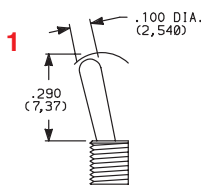

L1 .640" HIGH

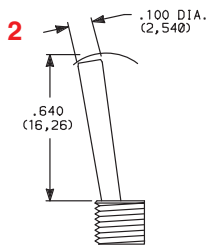

P3 ANTI-ROTATION, FLATTED,
.450" HIGH

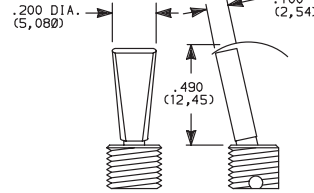

Available with T & T9 bushings only.
Dress nut part number 709901201
supplied standard with threaded bushing.

1 Actuator shown with standard H bushing.
Subtract .040 (1,02) for TD and D9 bushings,
subtract .090 (2,29) for T, T9, TK, K9 &
CF bushings.
2 Actuators shown with T, T9, TK & CF bushings,
add .050 (1,27) for TD and D9 bushings,
add .090 (2,29) for H, H9, Y & Y9 bushings.
All actuators have chrome finish (except K).

K LOCKING LEVER

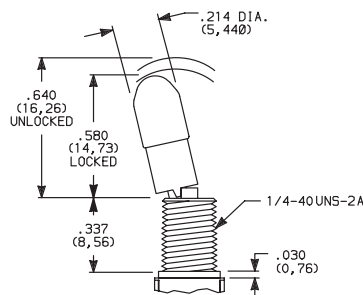

Locking Positions



-01 & -02 Models
2 Position lock



-03 & -11 Models
3 Position lock



-08 Models
1 Position lock

K actuators have natural aluminum finish.

Not available with CF bushing option.

Bushing option code not required. Not available with TX05 & TX07 models.

Keyway on right side. To prevent accidental actuation, toggles
must be lifted before being actuated. When released, toggles
again lock in place. Overtightening mounting nut may cause
actuator to bind.

BUSHING

H .220" HIGH THREADED, FLAT

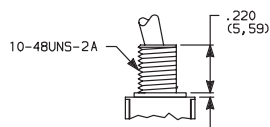
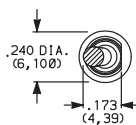

H standard with C, W & Z terminations.
H9 standard with A, AV & V3 terminations.

Y .220" HIGH THREADED, KEYWAY

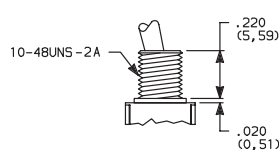
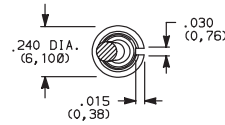

T .310" HIGH THREADED, FLAT

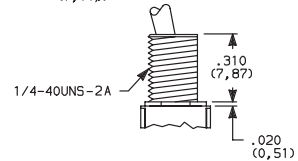
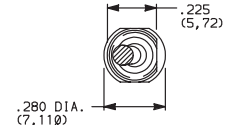

Third Angle
Projection

Dimensions are shown: Inches (mm)
Specifications and dimensions subject to change

C&K



T Series Subminiature Toggle Switches

BUSHING

TK .310" HIGH THREADED, KEYWAY

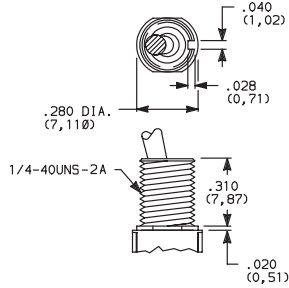

TD .260" HIGH THREADED, KEYWAY

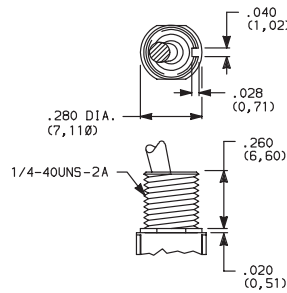

D9 .260" HIGH UNTHREADED, KEYWAY

CF SPLASHPROOF, .310" HIGH THREADED, FLAT

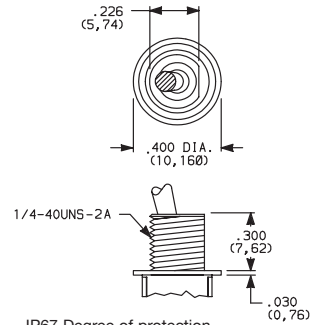

IP67 Degree of protection.
Internal o-ring actuator seal and external bushing seal washer standard.

Not available with K locking lever option.

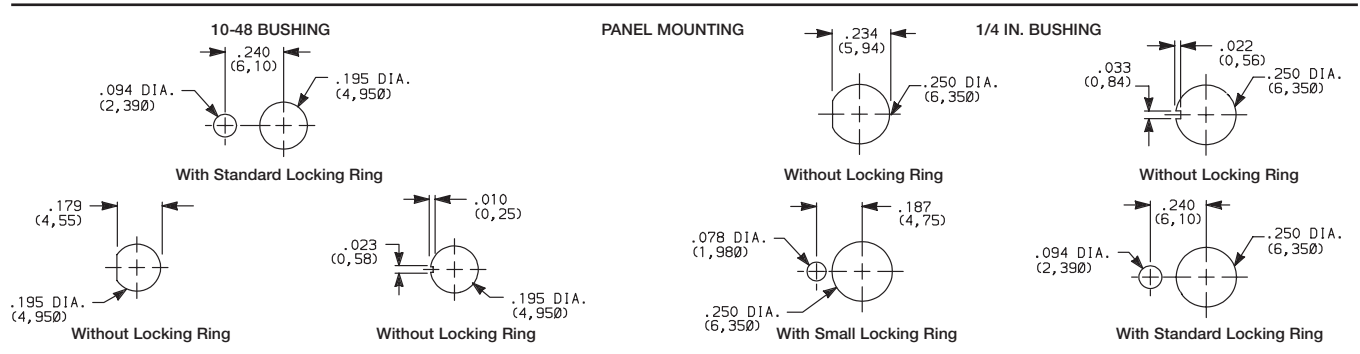

TERMINATIONS

Z SOLDER LUG

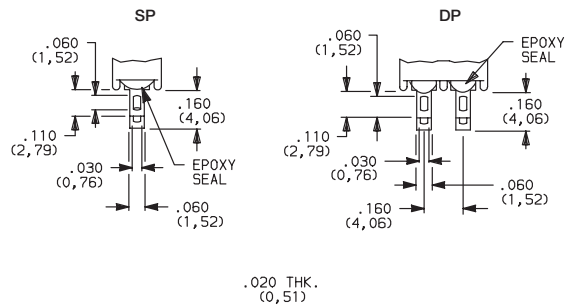

Not available with P or R contact materials.

C PC THRU-HOLE

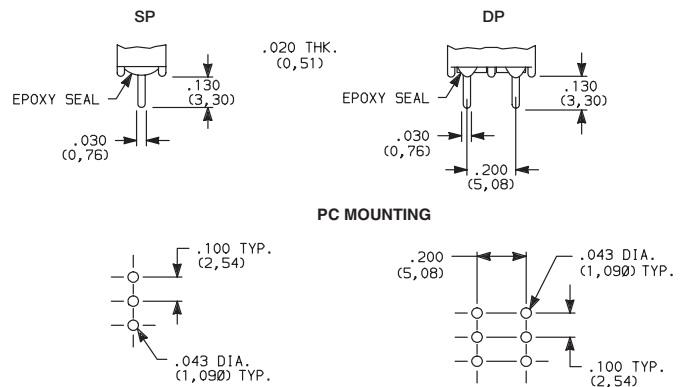

T102 - omit center hole.

W WIRE WRAP

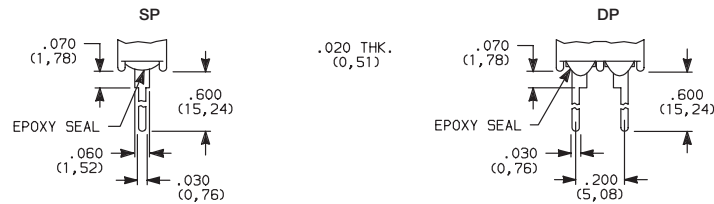

Third Angle
Projection

Dimensions are shown: Inches (mm)
Specifications and dimensions subject to change

www.ck-components.com



Toggle



T Series Subminiature Toggle Switches

TERMINATIONS

A RIGHT ANGLE, PC THRU-HOLE

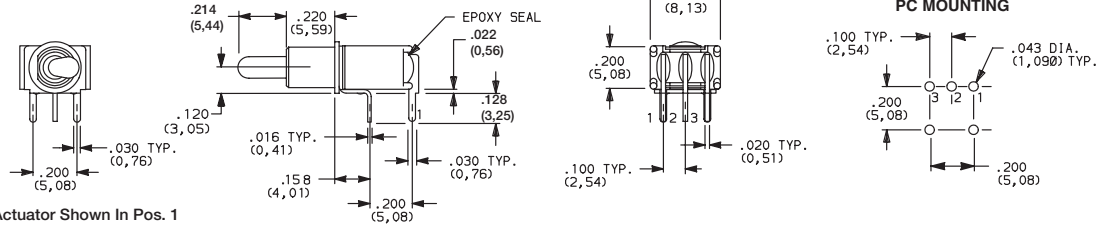

Actuator Shown In Pos. 1

Not available with T102 model.



T101MH9ABE
Horizontal Actuation
SPDT

A RIGHT ANGLE, PC THRU-HOLE

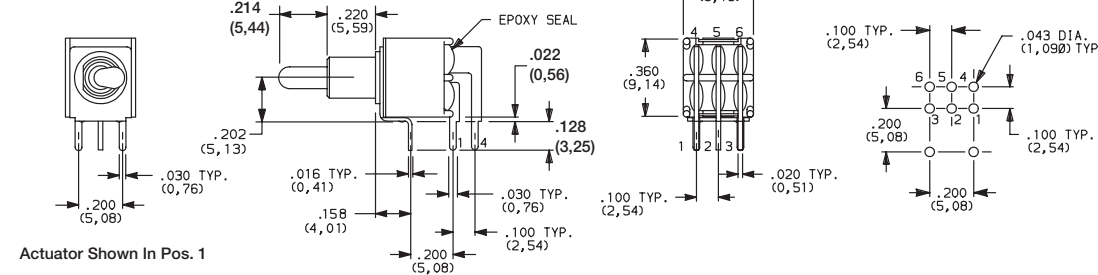

Actuator Shown In Pos. 1

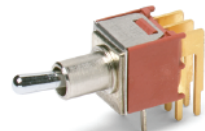

T201MH9ABE
Horizontal Actuation
DPDT

AV VERTICAL RIGHT ANGLE, PC THRU-HOLE

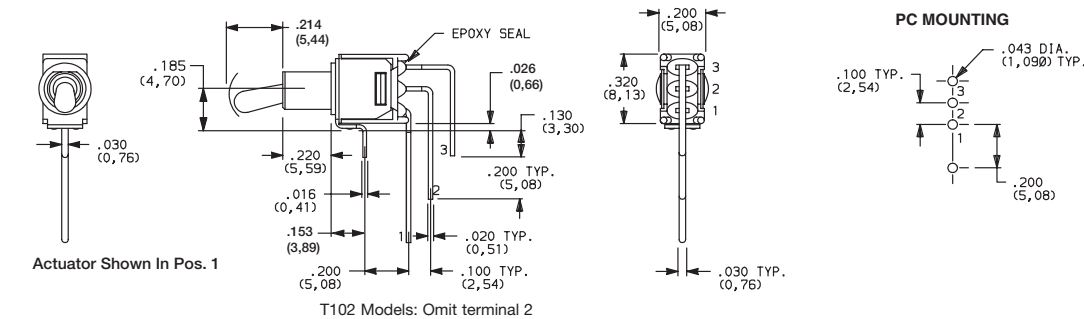

Actuator Shown In Pos. 1

T102 Models: Omit terminal 2

NOTE: Terminal bend radii and lead-in manufacturing option.

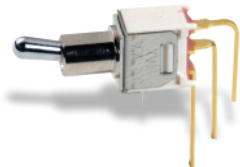

T101MH9AVBE
Vertical Actuation
SPDT

AV VERTICAL RIGHT ANGLE, PC THRU-HOLE

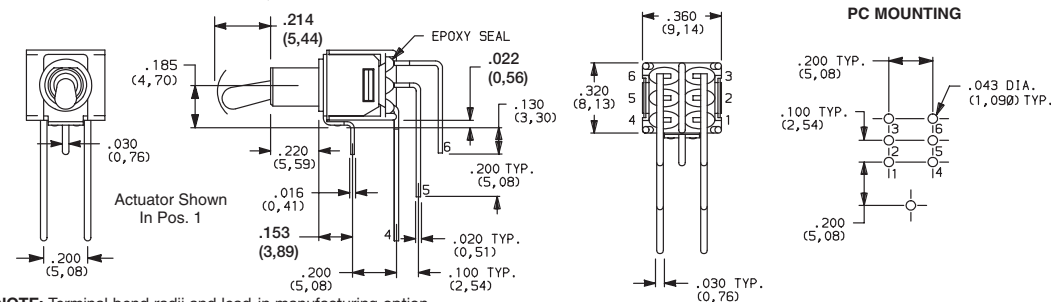

Actuator Shown In Pos. 1

NOTE: Terminal bend radii and lead-in manufacturing option.

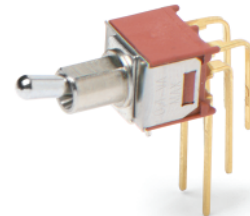

T201MH9AVBE
Vertical Actuation
DPDT

V3 VERTICAL MOUNT, V-BRACKET

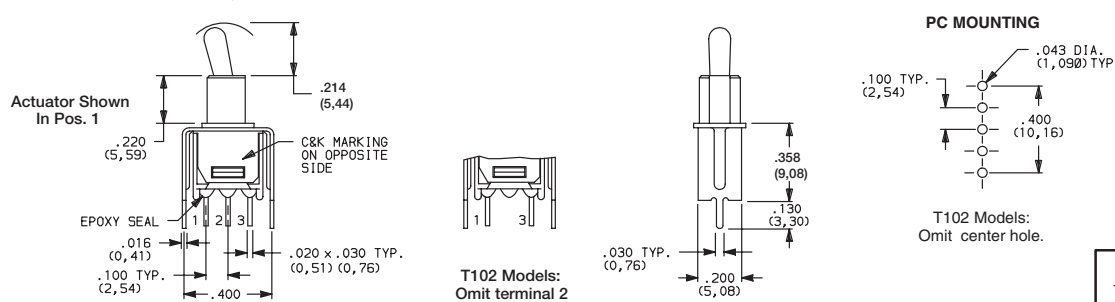

Actuator Shown In Pos. 1

T102 Models:
Omit terminal 2



T101MH9V3BE
SPDT



Third Angle
Projection

Dimensions are shown: Inches (mm)
Specifications and dimensions subject to change

www.ck-components.com



T Series Subminiature Toggle Switches

TERMINATIONS

V3 VERTICAL MOUNT, V-BRACKET



T201MH9V3BE
DPDT

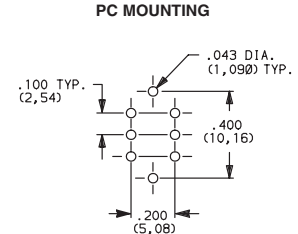
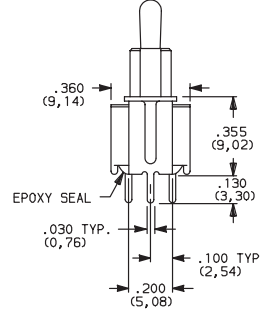
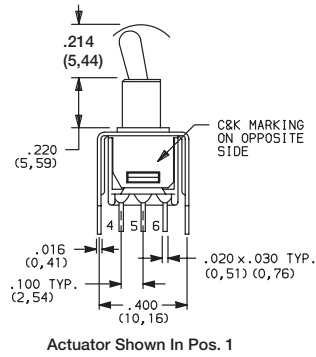

CONTACT MATERIAL

| OPTION CODE | CONTACT MATERIAL | TERMINAL PLATING | RATINGS | |
|-------------|------------------------------------|------------------------|-----------------------------------|---|
| | | | | |
| B | GOLD ¹ | GOLD ¹ | LOW LEVEL/ DRY CIRCUIT | 0.4 VA MAX. @ 20 V AC OR DC MAX. |
| P | | MATTE-TIN ⁶ | | |
| Q | SILVER ^{4,5} | SILVER ⁵ | POWER | TX01 MODELS: 3 AMPS @ 120 V AC OR 28 V DC. ALL OTHER MODELS: 2 AMPS @ 120 V AC OR 28 V DC. |
| G | GOLD OVER SILVER ^{2,3} | GOLD ³ | LOW LEVEL/DRY CIRCUIT OR POWER | TX01 MODELS: 0.4 VA MAX @ 20 V AC OR DC MAX. OR 3 AMPS @ 120 V AC OR 28 V DC. ALL OTHER MODELS: 0.4 VA MAX @ 20 V AC OR DC MAX. OR 2 AMPS @ 120 V AC OR 28 V DC. |
| R | | MATTE-TIN ⁶ | | |

* Note: See Technical Data section of this catalog for RoHS compliant and compatible definitions and specifications.

- ¹ CONTACTS & TERMINALS: Copper alloy, with gold plate over nickel plate.
- ² END CONTACTS: Coin silver, with gold plate over nickel plate.
- ³ CENTER CONTACTS & ALL TERMINALS: Copper alloy, with gold plate over nickel plate.
- ⁴ END CONTACTS: Coin silver, silver plated.
- ⁵ CENTER CONTACT & ALL TERMINALS: Copper alloy, silver plated.
- ⁶ TERMINALS: Copper alloy, with matte-tin over nickel plate.

All models with all options when ordered with R, G, or Q contact material.
B contact material standard with A, AV, V3 & W terminations.
Q contact material standard with C & Z terminations.

SEAL

E EPOXY SEAL

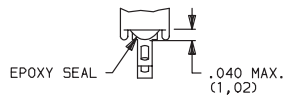

AVAILABLE HARDWARE

759D02000 SEALING BOOT

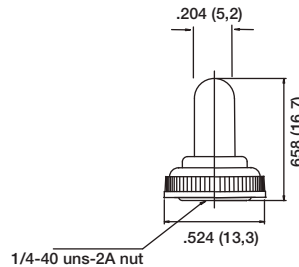

* Note: For use with S1 actuator style when combined with T, TK, and CF bushings.

Toggle



Dimensions are shown: Inches (mm)
Specifications and dimensions subject to change

GT Series Sealed Ultraminiature Toggle Switches

Features/Benefits

- Sealed against solder and cleaning process contaminants
- Ultraminiature size, smallest footprint available
- Thru-hole and surface mount models
- High temperature materials (UL 94V-0)
- RoHS compliant and compatible

Typical Applications

- Hand-held telecommunications
- Small instrumentation

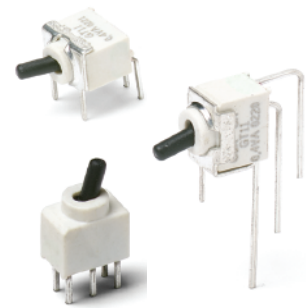

Specifications

CONTACT RATING: 0.4 VA max. @ 20 V AC or DC max.
 MECHANICAL & ELECTRICAL LIFE: 40,000 make-and-break cycles at full load.
 CONTACT RESISTANCE: Below 50 m Ω typ. initial @ 2-4 V DC, 100 mA.
 INSULATION RESISTANCE: 10⁹ Ω min.
 DIELECTRIC STRENGTH: 500 Vrms min. @ sea level.
 OPERATING TEMPERATURE: -30°C to 85°C.
 SOLDERABILITY: Per MIL-STD-202F method 208D, or EIA RS-186E method 9 (1 hour steam aging).
 PACKAGING: Surface mount switches shipped in anti-static tape and reel packaging per EIA 481-3, see page F-47 for drawings and reel information. Tape and cover strip are conductive for use near statically sensitive components, consult Customer Service Center.

Materials

HOUSING AND BASE: Glass filled nylon 4/6, flame retardant, heat stabilized (UL 94V-0).
 ACTUATOR: Glass filled nylon 4/6, flame retardant, heat stabilized (UL 94V-0), with standard internal o-ring seal.
 SWITCH SUPPORT: Brass, tin plated.
 MOVABLE CONTACTS: Copper alloy, with gold plate over nickel plate.
 STATIONARY CONTACTS: Copper alloy, with gold plate over nickel plate.
 TERMINALS: Gold.
 TERMINAL SEAL: Epoxy. All terminals insert molded.

NOTE: Specifications and materials listed above are for switches with standard options. For information on specific and custom switches, consult Customer Service Center.

How To Order

Complete part numbers for GT Series Sealed Ultraminiature Toggle Switches are shown on pages F-43 thru F-47.



GT11MCBE
SPDT

| PART NUMBER | SWITCH FUNCTION | | |
|-----------------|----------------------------------|--------|--------|
| | POS. 1 | POS. 2 | POS. 3 |
| GT11MCBE | ON | NONE | ON |
| GT13MCBE | ON | OFF | ON |
| Conn. Terms. | 2-3 | OPEN | 2-1 |
| Schematic | | | |
| SPDT | Note: Pins 4 and 6 not connected | | |
| GT12MCBE | OFF | NONE | ON |
| Conn. Terms. | OPEN | N/A | 3-1 |
| Schematic | | | |
| SPST | Note: Pins 4 and 6 not connected | | |

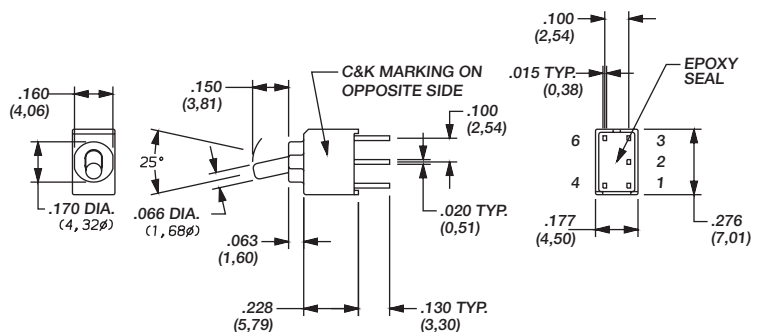

ACTUATOR SHOWN IN POS. 1

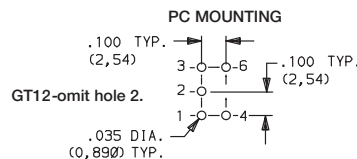

TERMINAL NOS. FOR
REFERENCE ONLY

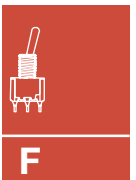

Toggle



Dimensions are shown: Inches (mm)
Specifications and dimensions subject to change

GT Series Sealed Ultraminiature Toggle Switches

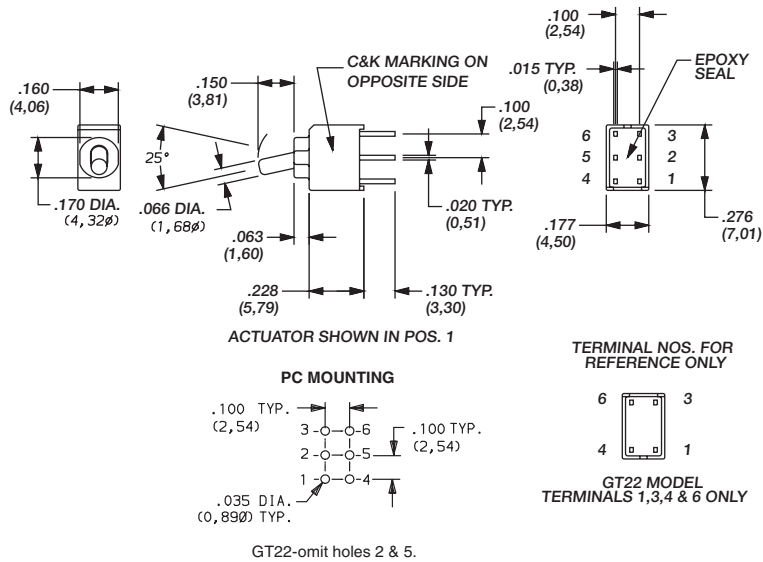

| PART NUMBER | SWITCH FUNCTION | | |
|------------------------------------|-----------------|--------|----------|
| | POS. 1 | POS. 2 | POS. 3 |
| GT21MCBE GT23MCBE | ON | NONE | ON |
| Conn. Terms. | 2-3, 5-6 | OPEN | 2-1, 5-4 |
| Schematic | | | |
| DPDT | | | |
| GT22MCBE | OFF | NONE | ON |
| Conn. Terms. | OPEN | N/A | 3-1 |
| Schematic | | | |
| DPST | | | |

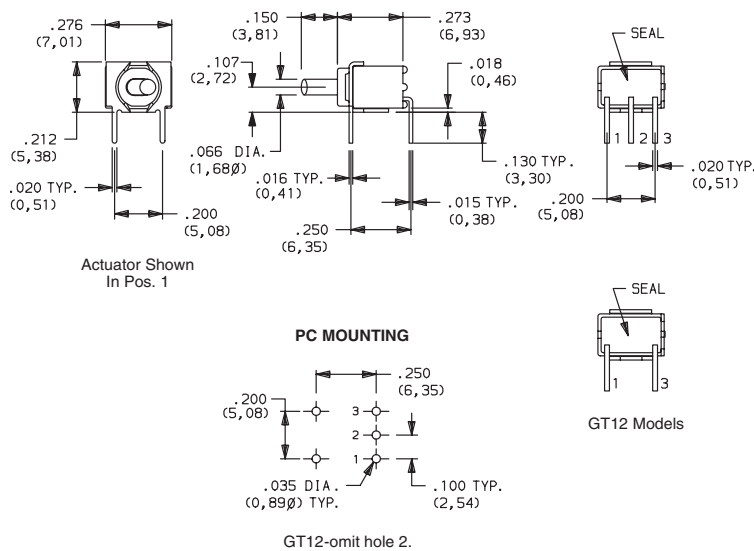

| PART NUMBER | SWITCH FUNCTION | | |
|------------------------------------|-----------------|--------|--------|
| | POS. 1 | POS. 2 | POS. 3 |
| GT11MABE GT13MABE | ON | NONE | ON |
| Conn. Terms. | 2-3 | OPEN | 2-1 |
| Schematic | | | |
| SPDT | | | |
| GT12MABE | OFF | NONE | ON |
| Conn. Terms. | OPEN | N/A | 3-1 |
| Schematic | | | |
| SPST | | | |

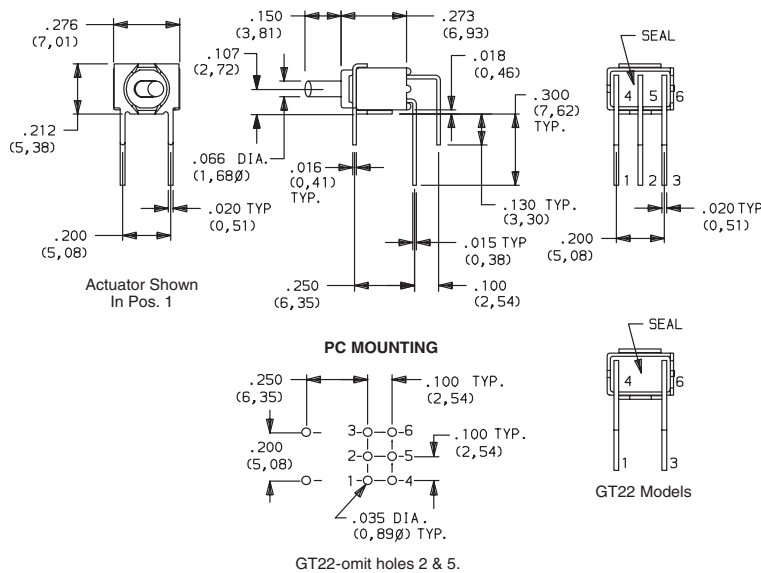

| PART NUMBER | SWITCH FUNCTION | | |
|------------------------------------|-----------------|--------|----------|
| | POS. 1 | POS. 2 | POS. 3 |
| GT21MABE GT23MABE | ON | NONE | ON |
| Conn. Terms. | 2-3, 5-6 | OPEN | 2-1, 5-4 |
| Schematic | | | |
| DPDT | | | |
| GT22MABE | OFF | NONE | ON |
| Conn. Terms. | OPEN | N/A | 3-1, 6-4 |
| Schematic | | | |
| DPST | | | |

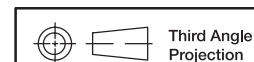

Dimensions are shown: Inches (mm)
Specifications and dimensions subject to change

GT Series Sealed Ultraminiature Toggle Switches



GT11MAVBE
Vertical
Actuation
SPDT

| PART NUMBER | SWITCH FUNCTION | | |
|--------------------------------------|-----------------|--------|--------|
| | POS.1 | POS. 2 | POS. 3 |
| GT11MAVBE GT13MAVBE | ON | NONE | ON |
| Conn. Terms. | 2-3 | OPEN | 2-1 |
| Schematic | | | |
| SPDT | | | |
| GT12MAVBE | OFF | NONE | ON |
| Conn. Terms. | OPEN | N/A | 3-1 |
| Schematic | | | |
| SPST | | | |

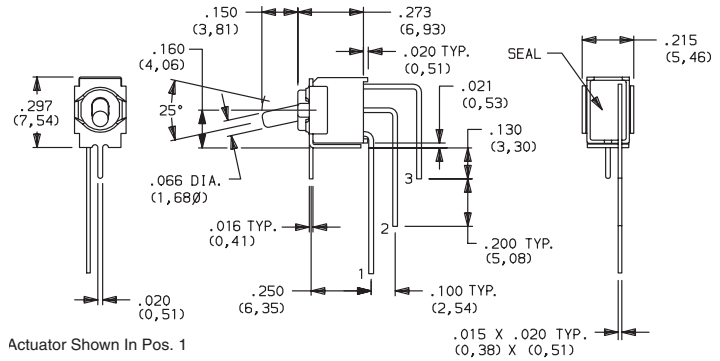

Actuator Shown In Pos. 1

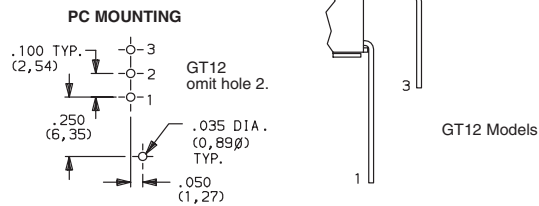

GT21MAVBE
Vertical
Actuation
DPDT

| PART NUMBER | SWITCH FUNCTION | | |
|--------------------------------------|-----------------|--------|----------|
| | POS.1 | POS. 2 | POS. 3 |
| GT21MAVBE GT23MAVBE | ON | NONE | ON |
| Conn. Terms. | 2-3, 5-6 | OPEN | 2-1, 5-4 |
| Schematic | | | |
| DPDT | | | |
| GT22MAVBE | OFF | NONE | ON |
| Conn. Terms. | OPEN | N/A | 3-1, 6-4 |
| Schematic | | | |
| DPST | | | |

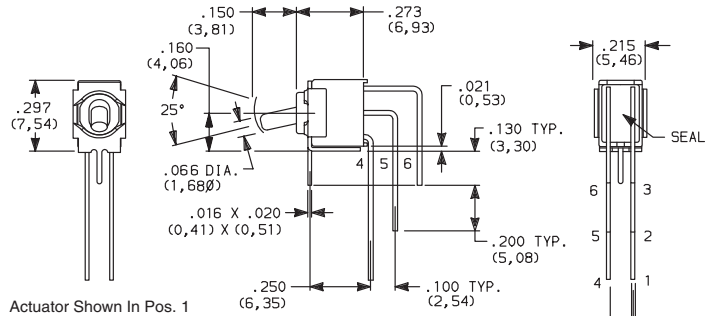

Actuator Shown In Pos. 1

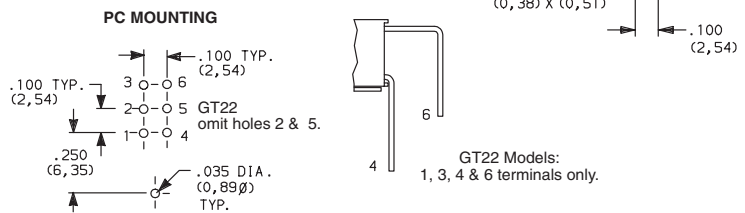

GT11MV3BE
SPDT

| PART NUMBER | SWITCH FUNCTION | | |
|--------------------------------------|----------------------------------|--------|--------|
| | POS.1 | POS. 2 | POS. 3 |
| GT11MV3BE GT13MV3BE | ON | NONE | ON |
| Conn. Terms. | 2-3 | OPEN | 2-1 |
| Schematic | | | |
| SPDT | Note: Pins 4 and 6 not connected | | |
| GT12MV3BE | OFF | NONE | ON |
| Conn. Terms. | OPEN | N/A | 3-1 |
| Schematic | | | |
| SPST | Note: Pins 4 and 6 not connected | | |

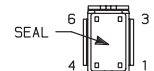
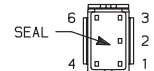
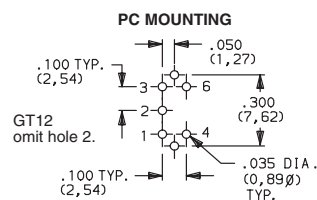
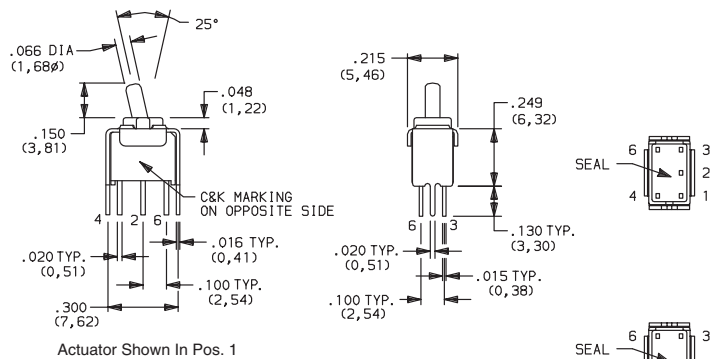

GT12 Models



Dimensions are shown: Inches (mm)
Specifications and dimensions subject to change



GT Series Sealed Ultraminiature Toggle Switches

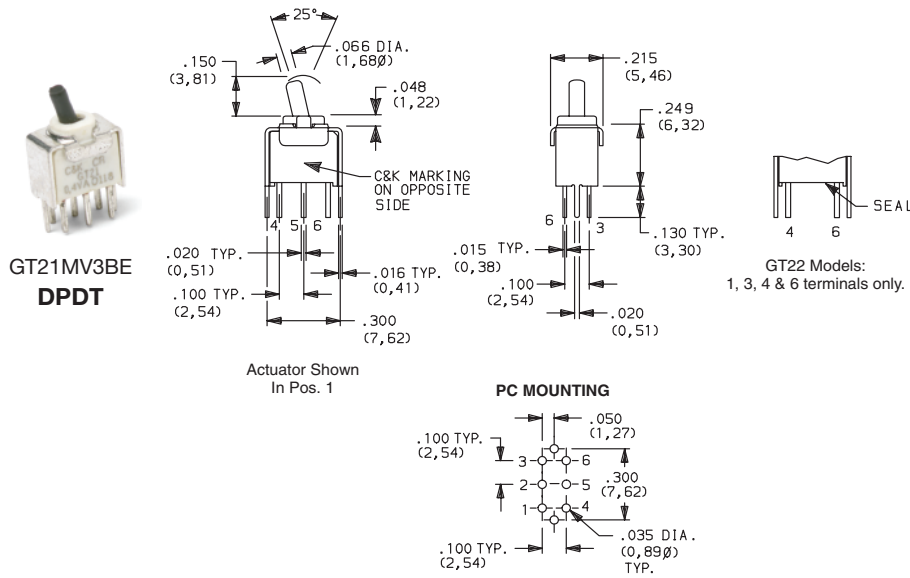

| PART NUMBER | SWITCH FUNCTION | | |
|--------------------------------------|-----------------|--------|----------|
| | POS.1 | POS. 2 | POS. 3 |
| GT21MV3BE GT23MV3BE | ON | NONE | ON |
| Conn. Terms. | 2-3, 5-6 | OPEN | 2-1, 5-4 |
| Schematic | | | |
| GT22MV3BE | OFF | NONE | ON |
| Conn. Terms. | OPEN | N/A | 3-1, 6-4 |
| Schematic | | | |
| DPST | | | |

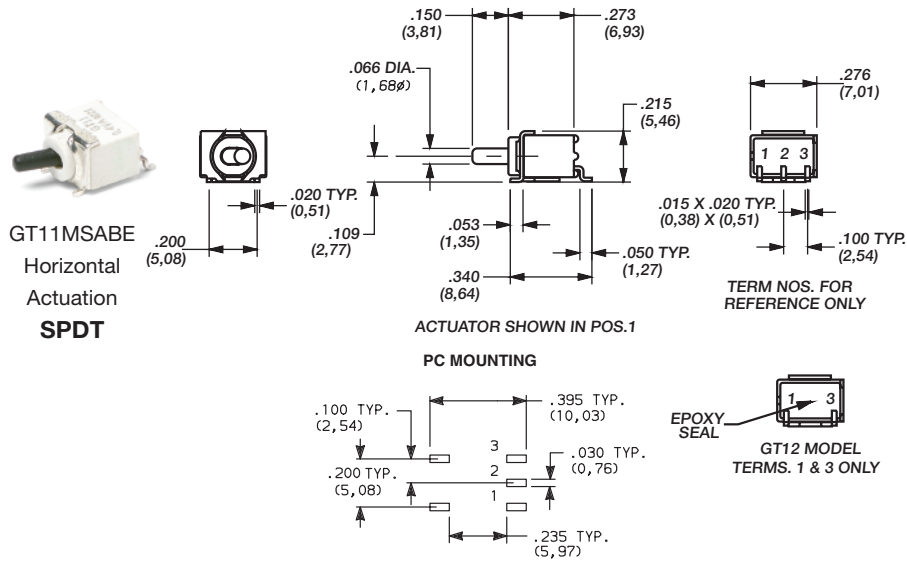

| PART NUMBER | SWITCH FUNCTION | | |
|--|-----------------|--------|--------|
| | POS.1 | POS. 2 | POS. 3 |
| GT11MSABETR GT13MSABETR | ON | NONE | ON |
| Conn. Terms. | 2-3 | OPEN | 2-1 |
| Schematic | | | |
| GT12MSABETR | OFF | NONE | ON |
| Conn. Terms. | OPEN | N/A | 3-1 |
| Schematic | | | |
| SPST | | | |

Standard with tape & reel packaging, see page F-47. GT12-omit pad 2.

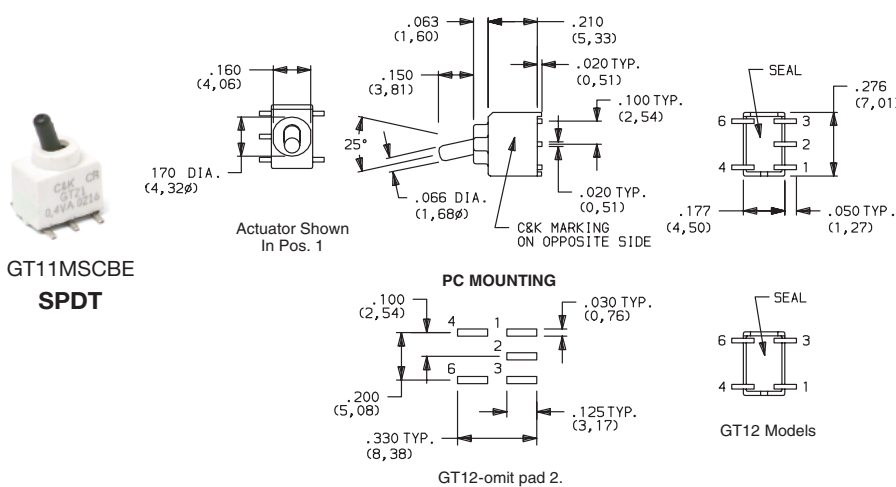

| PART NUMBER | SWITCH FUNCTION | | |
|--|-----------------|--------|--------|
| | POS.1 | POS. 2 | POS. 3 |
| GT11MSCBETR GT13MSCBETR | ON | NONE | ON |
| Conn. Terms. | 2-3 | OPEN | 2-1 |
| Schematic | | | |
| GT12MSCBETR | OFF | NONE | ON |
| Conn. Terms. | OPEN | N/A | 3-1 |
| Schematic | | | |
| SPST | | | |

Note: Pins 4 and 6 not connected

Standard with tape & reel packaging, see page F-47.



Toggle



Dimensions are shown: Inches (mm)
Specifications and dimensions subject to change

GT Series Sealed Ultraminiature Toggle Switches



GT21MSCBE
DPDT

| PART NUMBER | SWITCH FUNCTION | | |
|--------------------|-----------------|--------|----------|
| | POS. 1 | POS. 2 | POS. 3 |
| GT21MSCBETR | ON | NONE | ON |
| GT23MSCBETR | ON | OFF | ON |
| Conn. Terms. | 2-3, 5-6 | OPEN | 2-1, 5-4 |
| Schematic | | | |
| DPDT | | | |
| GT22MSCBETR | OFF | NONE | ON |
| Conn. Terms. | OPEN | N/A | 3-1, 6-4 |
| Schematic | | | |
| DPST | | | |

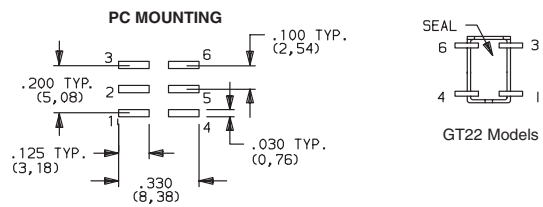
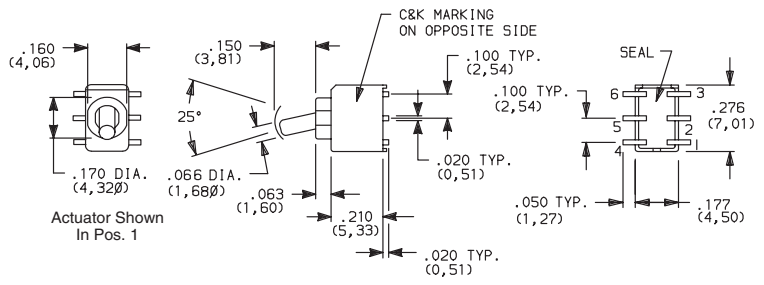

GT22-omit pads 2 & 5.
Standard with tape & reel packaging

TAPE & REEL

For part numbers GT11MSABE, GT12MSABE, GT13MSABE

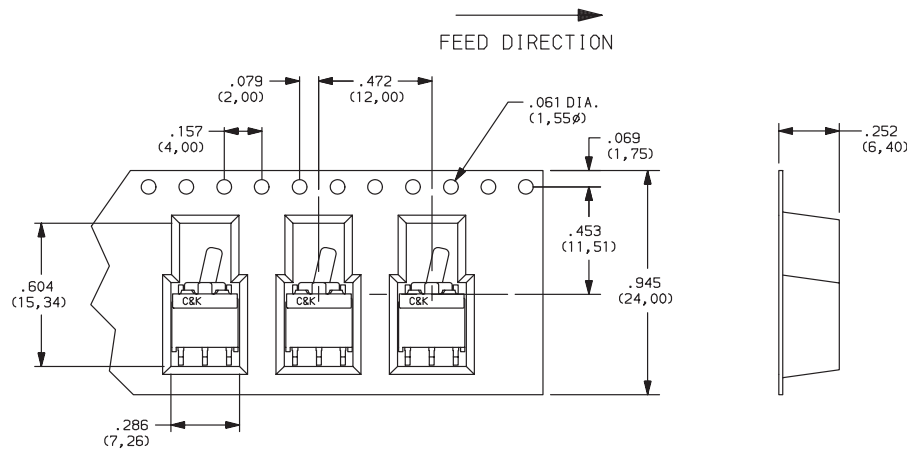

| REEL INFORMATION | |
|-------------------|---------------|
| OUTSIDE DIAMETER | 13.00 (330,0) |
| PILOT HOLE | .512 (13,0) |
| QUANTITY PER REEL | 600 |

For part numbers GT11MSCBE, GT12MSCBE, GT13MSCBE, GT21MSCBE, GT22MSCBE, GT23MSCBE,

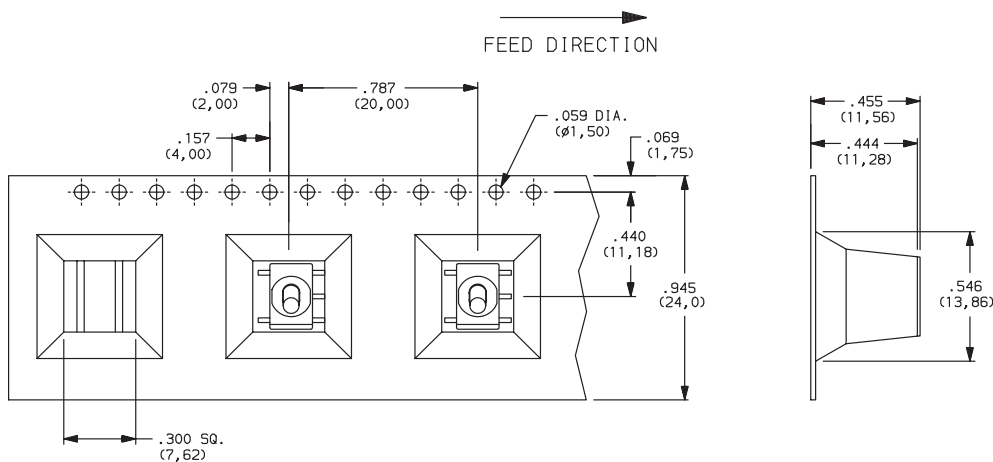

| REEL INFORMATION | |
|-------------------|---------------|
| OUTSIDE DIAMETER | 13.00 (330,0) |
| PILOT HOLE | .512 (13,0) |
| QUANTITY PER REEL | 200 |

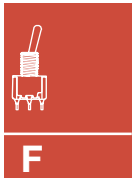

Toggle

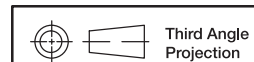

Third Angle
Projection

Dimensions are shown: Inches (mm)
Specifications and dimensions subject to change



9000 Series Power Toggle Switches

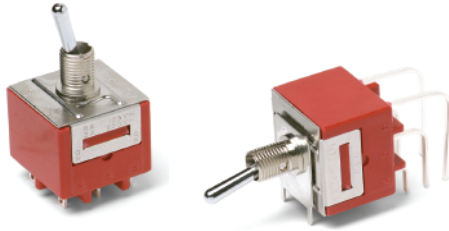

Features/Benefits

- Power ratings up to 10 AMPS
- Double pole models
- Locking lever options available
- Wide variety of actuator styles
- RoHS compliant and compatible

Typical Applications

- Shut-off switch
- Small equipment



UL 61058-1

Specifications

CONTACT RATING:

9201 Model

- GP (general purpose)
- 6 AMPS 125 VAC 50/60 Hz T85 10,000 cycles (10E3)
- 3 AMPS 250 VAC 50/60 Hz T85 10,000 cycles
- R (resistive)
- 6 AMPS 30 VDC T85 10,000 cycles

9221 Model:

- GP (general purpose)
- 10 AMPS 125 VAC 50/60 Hz T85 10,000 cycles
- 5 AMPS 250 VAC 50/60 Hz T85 10,000 cycles
- R (resistive)
- 10 AMPS 30 VDC T85 10,000 cycles

ELECTRICAL LIFE: 25,000 make-and-break cycles at full load.

CONTACT RESISTANCE: Below 10 m Ω typ. initial @ 2-4 V DC, 100 mA.

INSULATION RESISTANCE: 10⁹ Ω min.

DIELECTRIC STRENGTH: 2,500 Vrms min. @ sea level.

OPERATING TEMPERATURE: -30°C to 85°C.

SOLDERABILITY: Per MIL-STD-202F method 208D, or EIA RS-186E method 9 (1 hour steam aging).

Materials

CASE: Diallyl phthalate (DAP) (UL 94V-0).

ACTUATOR: Brass, chrome plated.

BUSHING: Brass or zinc, nickel plated.

HOUSING: Stainless steel.

SWITCH SUPPORT: Brass or steel, matte-tin plated.

END CONTACTS: 9201 Model: Coin silver, silver plated.
9221 Model: Silver cadmium oxide.

CENTER CONTACTS: Copper alloy, silver plated

ALL TERMINALS: 9201 Model: Copper alloy, silver plated.
9221 Model: Copper alloy, matte-tin plated.

TERMINAL SEAL: Epoxy.

HARDWARE: Nut & Locking ring: Brass, nickel plated.
Lockwasher: Steel, nickel plated.

NOTE: Any models supplied with Q contact material are RoHS compliant and compatible.

NOTE: Specifications and materials listed above are for switches with standard options. For information on specific and custom switches, consult Customer Service Center.

Build-A-Switch

To order, simply select desired option from each category and place in the appropriate box. Available options are shown and described on pages F-49 thru F-52. For additional options not shown in catalog, consult Customer Service Center.

| | | |
|---|--|---|
| <p>Switch Function</p> <p>9201 DPDT, On-On, 6 Amps 9221 DPDT, On-On, 10 Amps</p> <p>Actuator</p> <p>S Antirotation, .410" high K Locking lever, .650" high K1 Locking lever, .680" high L43 Lever handle with cap P3 Flatted, anti-rotation, .450" high T .687" high, 15/32 bushing T1 .460" high, 15/32 bushing</p> | <p>Bushing</p> <p>H3 .296" high, keyway CW Splashproof H .296" high, flat</p> <p>Terminations</p> <p>Z Solder lug Z4 Quick connect (9221 only) AV2 Vert. right angle, PC thru-hole (9201 only) C PC Thru-hole</p> | <p>Contact Material</p> <p>Q Silver</p> <p>Seal</p> <p>E Epoxy D No epoxy</p> <p>Actuator Color/Finish</p> <p>NONE Bright chrome 2 Black</p> <p>Bushing Finish</p> <p>NONE Nickel 2 Black</p> <p>KXX Actuator Color/Finish</p> <p>NONE Natural aluminum 2 Black anodized aluminum</p> |
|---|--|---|



Toggle



Dimensions are shown: Inches (mm)
Specifications and dimensions subject to change

9000 Series Power Toggle Switches

SWITCH FUNCTION

| NO. POLES | MODEL NO. | RATING* | SWITCH FUNCTION | | CONNECTED TERMINALS | | SCHEMATIC |
|-----------|-----------|---------|------------------|------------------|---------------------|------------------|-----------|
| | | | POS. 1 KEYWAY | POS. 2 KEYWAY | POS. 1 KEYWAY | POS. 2 KEYWAY | |
| DP | 9201 | 6 AMPS | ON | ON | 2-3,5-6 | 2-1,5-4 | |
| | 9221 | 10 AMPS | ON | ON | | | |

DPDT

* See CONTACT MATERIAL, page F-52, for complete ratings.

All 9000 Series models meet international dimensional and electrical requirements.



9221 model must be ordered with Z4 terminations and D seal option.

ACTUATOR

S ANTIROTATION, .410" HIGH

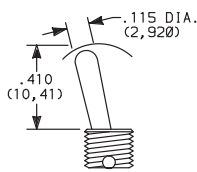

P3 FLATTED, ANTIROTATION, .450" HIGH

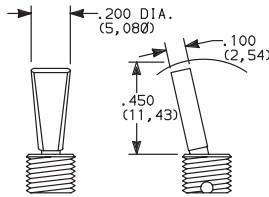

| OPTION CODE | ACTUATOR FINISH |
|-------------|---|
| NONE | NATURAL ALUMINUM—With Nickel Plated Bushing |
| 2 | BLACK |

NOTE: Black hardware is supplied when either black actuators or bushings are specified. All hardware is available separately, see Section N.

Antirotation is standard on all actuators, provides 'anti-push-in' feature on actuator.

Dress nut part number: 709901201 supplied standard with P3 actuator.

T .687" HIGH, 15/32 BUSHING

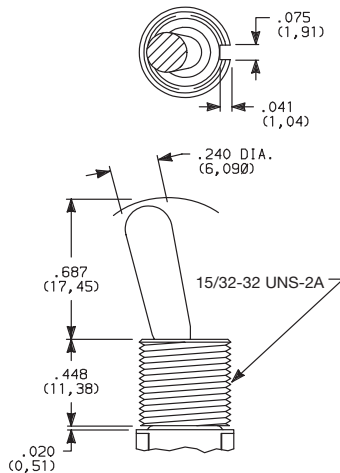

T1 .460" HIGH, 15/32 BUSHING

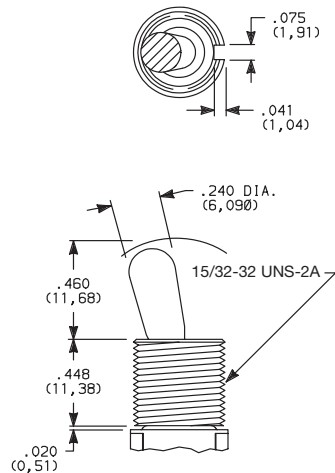

| OPTION CODE | ACTUATOR FINISH |
|-------------|--|
| NONE | BRIGHT CHROME—With Nickel Plated Bushing |
| 2 | BLACK |

NOTE: Bushing option code not required for T & T1 actuators unless CW splashproof bushing ordered.

Black hardware is supplied when either black actuators or bushings are specified. All hardware is available separately, see Section N.

Antirotation is standard on all actuators except T & T1, provides 'anti-push-in' feature on actuator.

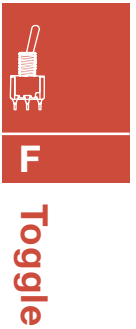

Dimensions are shown: Inches (mm)
Specifications and dimensions subject to change

9000 Series Power Toggle Switches

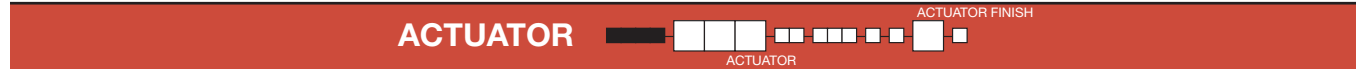

K LOCKING LEVER, .650" HIGH, THREADED

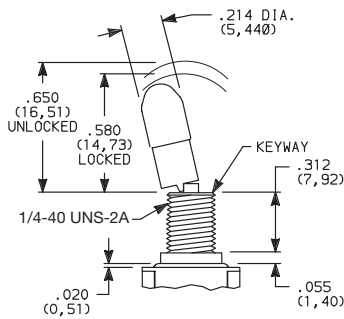

K1 LOCKING LEVER, .680" HIGH, THREADED

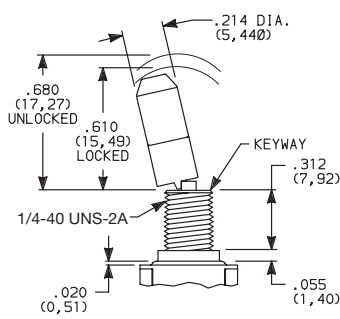

Locking Positions



2 Position Lock

NOTE: To prevent accidental actuation, toggles must be lifted before being actuated. When released, toggles again lock in place. Bushing option code not required. Overtightening mounting nut may cause actuator to bind.

| OPTION CODE | ACTUATOR CAP FINISH |
|-------------|---|
| NONE | NATURAL ALUMINUM—With Nickel Plated Bushing |
| 2 | BLACK ANODIZED ALUMINUM |

L40 LEVER HANDLE WITHOUT CAP

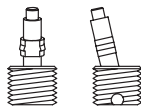

No color choice required.

L43 PLASTIC LEVER HANDLE WITH ANTIROTATION AND CAP, P/N 4812

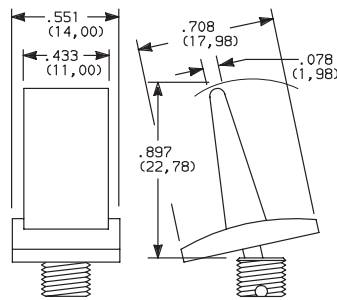

Finish: Matte

| OPTION CODE | ACTUATOR CAP COLOR |
|-------------|--------------------------------|
| 2 | BLACK |
| NONE | No Actuator Color (L40 option) |

Other colors available, consult Customer Service Center.

NOTE: Lever handle actuator L43 supplied, but not installed. For interchangeability, order L40 actuator option and order lever handles separately, see page F-52. Antirotation is standard on all actuators, provides 'anti-push-in' feature.



H3 .296" HIGH, THREADED, KEYWAY

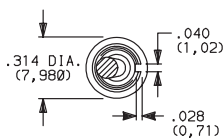

H .296" HIGH, THREADED, FLAT

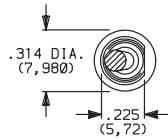

CW SPLASHPROOF, 15/32 BUSHING

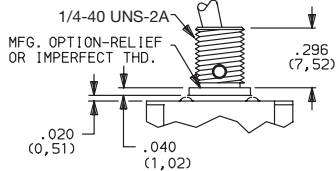
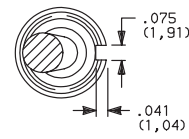

Will withstand 12 in./lbs. of torque with no distortion.

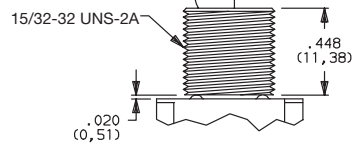
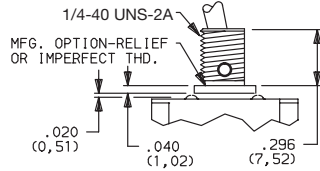

For T & T1 actuators only.

| OPTION CODE | BUSHING FINISH |
|-------------|----------------|
| NONE | NICKEL |
| 2 | BLACK |

NOTE: Two mounting nuts, locking ring and lockwasher supplied standard with threaded bushings. Black hardware is supplied when either black bushings or actuators are specified. Optional mounting nut and locking ring styles and finishes available, see Section N.

Internal actuator seal standard. External bushing seal available separately from APM Hexseal, part # MFS-60064.

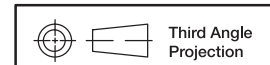

Third Angle Projection

Dimensions are shown: Inches (mm)
Specifications and dimensions subject to change



Toggle



9000 Series Power Toggle Switches

BUSHING

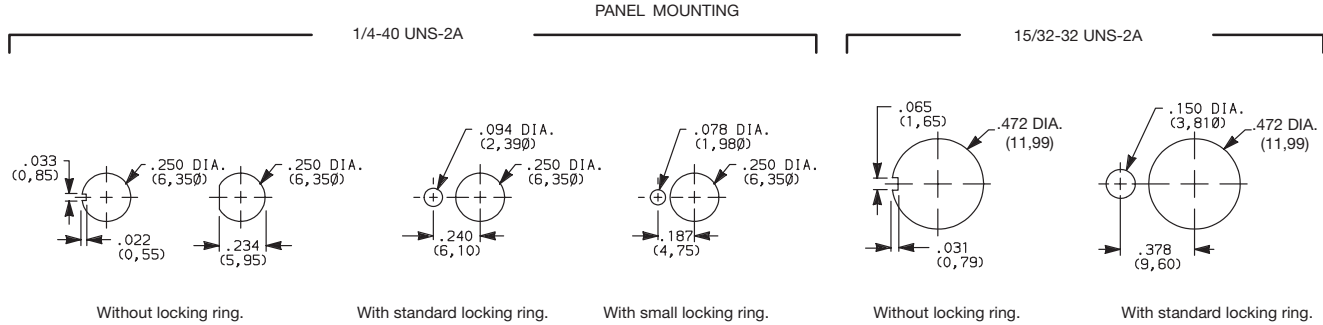

TERMINATIONS

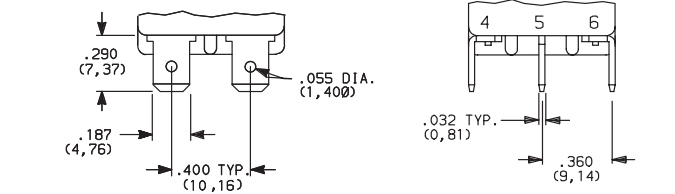
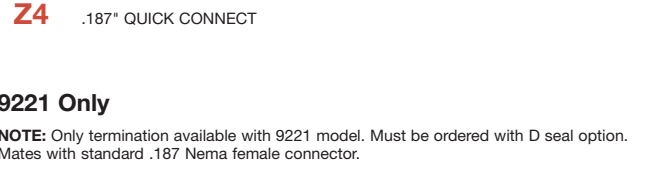
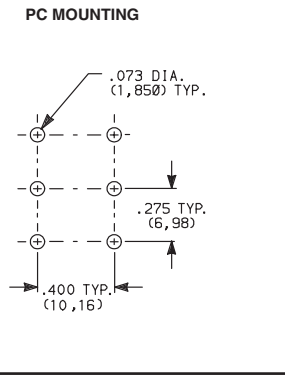
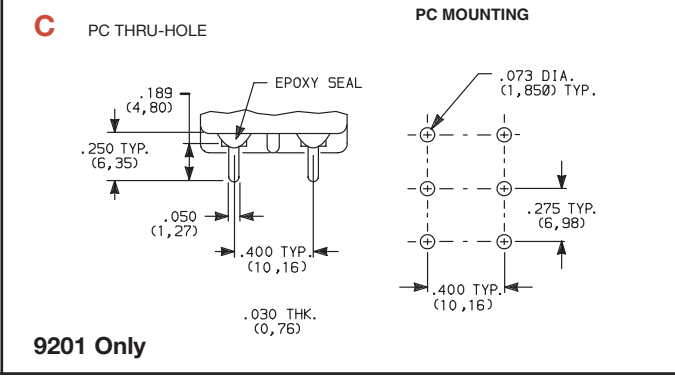
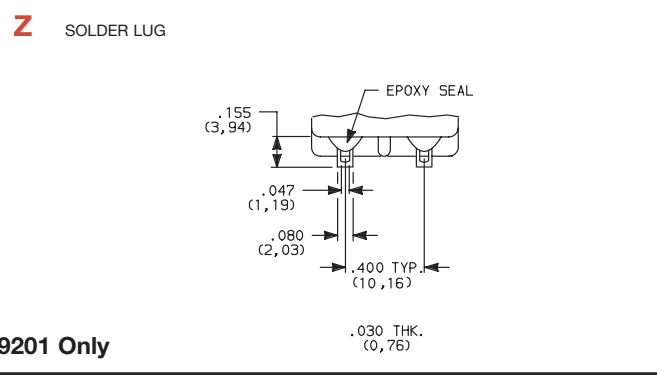

AV2 VERTICAL RIGHT ANGLE, PC THRU-HOLE

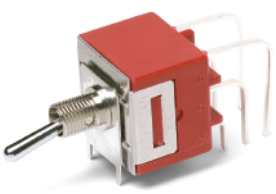
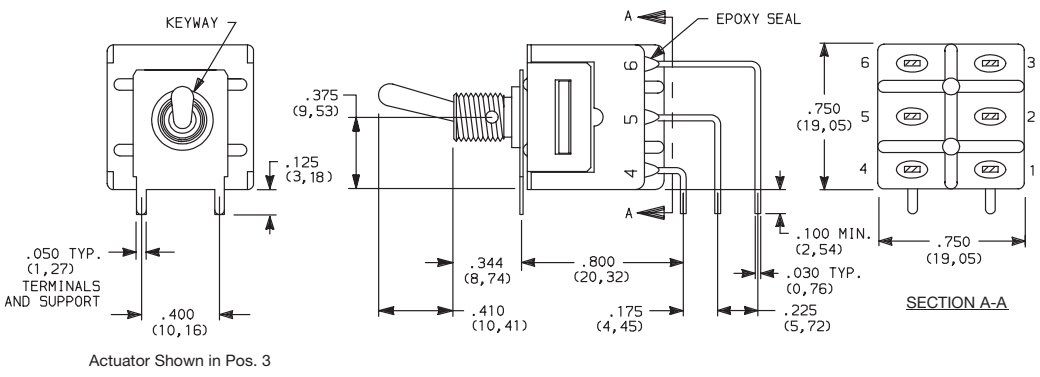

9201SH3AV2QE
Vertical Actuation
DPDT

9201 Only

NOTE: Terminal bend radii and lead-in manufacturing option. Terminal spacing greater than 3mm at all points.

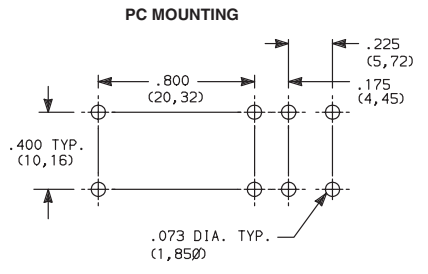

Terminal Nos. For Reference Only

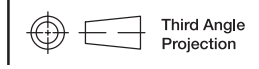

Dimensions are shown: Inches (mm)
Specifications and dimensions subject to change



Toggle

9000 Series Power Toggle Switches

CONTACT MATERIAL

| OPTION CODE | MODEL | CONTACT MATERIAL | TERMINAL PLATING | RATINGS |
|-------------|-------|----------------------------|-------------------|---|
| Q | 9201 | SILVER 1,2 | SILVER OR TIN 2,5 | GP (general purpose) 6 AMPS 125 VAC 50/60 Hz T85 10,000 cycles (10E3) 3 AMPS 250 VAC 50/60 Hz T85 10,000 cycles R (resistive) 6 AMPS 30 VDC T85 10,000 cycles |
| | 9221 | SILVER CADMIUM OXIDE 3,4,6 | TIN 5 | GP (general purpose) 10 AMPS 125 VAC 50/60 Hz T85 10,000 cycles 5 AMPS 250 VAC 50/60 Hz T85 10,000 cycles R (resistive) 10 AMPS 30 VDC T85 10,000 cycles |

* Note: See Technical Data section of this catalog for RoHS compliant and compatible definitions and specifications.

¹ END CONTACTS: Coin silver, silver plated.

² CENTER CONTACTS & ALL TERMINALS: Copper alloy, silver plated.

³ END CONTACTS: Silver cadmium oxide.

⁴ CENTER CONTACTS: Copper alloy, silver plated.

⁵ Z4 TERMINALS ONLY: Copper alloy, matte-tin plated.

⁶ Cadmium in electrical switch contacts is exempt from RoHS.

NOTE: Any models supplied with Q contact material are RoHS compliant.

All 9000 Series models meet international dimensional and electrical requirements.

9221 model must be ordered with Z4 terminations and D seal option.



SEAL

E EPOXY SEAL

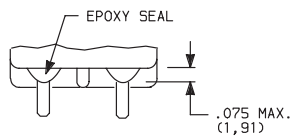

Not available with 9221 model or Z4 terminations.

D NO EPOXY SEAL

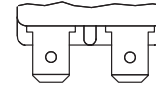

Must be ordered with 9221 model and Z4 termination.

AVAILABLE HARDWARE

Cap
Compatible with S actuator

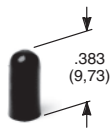

PART NO.
896801000 WHITE
896802000 BLACK
896803000 RED
 Material: Polyethylene
 Finish: Matte

Cap
Compatible with S actuator



PART NO.
706201000 WHITE
706202000 BLACK
706203000 RED
 Material: Vinyl
 Finish: Matte

L43 Actuator

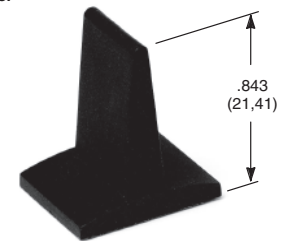

PART NO.
481202000 BLACK
481203000 RED
 Material: Nylon
 Finish: Matte
NOTE: Additional nuts, locking rings and lockwashers available separately, see Section N.
 Other colors available, consult Customer Service Center.

759D02000 Sealing Boot

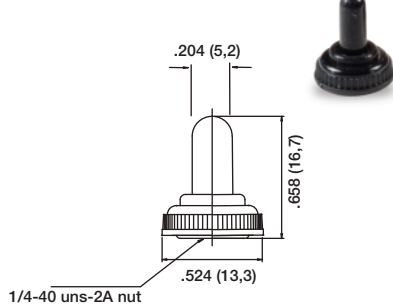

NOTE: For use with S actuator style when combined with H3 and H bushings

703D02000 Sealing Boot

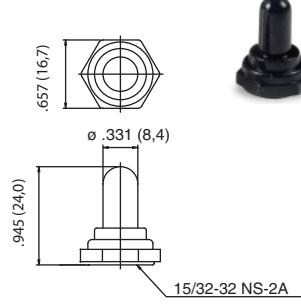

NOTE: For use with T style actuator

704D02000 Sealing Boot

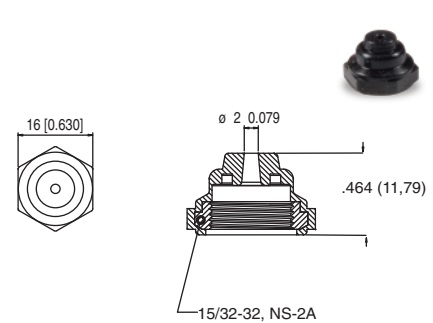

NOTE: For use with T style actuator

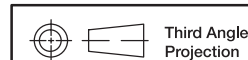













Dimensions are shown: Inches (mm)
Specifications and dimensions subject to change

www.ck-components.com

Rockers

Product Selection Guide

| Rocker |  |  |  |  |  |  |  |
|----------------------------|---|---|---|--|---|---|---|
| Series | 7000 | E | ET | T | 9000 | DA | D |
| Switch Type | Miniature | Miniature | Subminiature | Subminiature | Power Rocker & Lever Handle | Miniature Power | Miniature Power |
| Poles/Throws | SPDT, DPDT, 3PDT, 4PDT | SPDT, DPDT, 3PDT | SPST, SPDT, DPDT | SPST, SPDT, DPDT | DPDT | SPST, SPDT | SPST, SPDT, DPST, DPDT |
| Max. Current | 5 Amps | 7.5 Amps | 3 Amps | 3 Amps | 10 Amps | 16 Amps 10 Amps | 4 Amps 10 Amps |
| Washable | | • | • | | | | |
| Illuminated | | | | | | • | |
| Panel Mount Options | | | | | | | |
| Front Mount | • | • | | • | • | Snap-in | Snap-in |
| Rear Mount | • | • | | • | • | | |
| PCB Mount Options | | | | | | | |
| Vertical | • | • | • | • | • | • | • |
| Right Angle | • | • | • | • | • | • | • |
| Surface Mount | | | • | | | | |
| Page No. | G-3 | G-25 | G-39 | G-45 | G-51 | G-56 | G-60 |

| Rocker |  |  |  |  |  |
|----------------------------|---|---|---|--|---|
| Series | DM | DM | DF | CR | SW |
| Switch Type | Miniature 2 Pole Power | Miniature Illuminated Power | Power | Round | Miniature Power |
| Poles/Throws | DPST, DPDT | SPST, DPST | SPST, SPDT, DPST | SPST, SPDT | SPST, SPDT, DPST |
| Max. Current | 3 Amps, 10 Amps | 3 Amps, 10 Amps | 16 Amps | 10 Amps, 6 Amps | 3 A, 6 A, 6.5 A, 10 A, 16 A |
| Washable | | | | | |
| Illuminated | | • | | • | • |
| Panel Mount Options | | | | | |
| Front Mount | Snap-in | Snap-in | Snap-in | Snap-in | Snap-in |
| Rear Mount | | | • | | |
| PCB Mount Options | | | | | |
| Vertical | | | | | |
| Right Angle | | | • | | |
| Surface Mount | | | | | |
| Page No. | G-65 | G-69 | G-73 | G-77 | G-81 |

Rocker



G



*Dimensions are shown: Inches (mm)
Specifications and dimensions subject to change*

7000 Series Miniature Rocker & Lever Handle Switches

Features/Benefits

- Multi-pole and multi-position
- Wide variety of actuator and termination options
- Epoxy terminal-seal compatible with bottom wash cleaning
- RoHS compliant

Typical Applications

- Telecommunications
- Instrumentation
- Medical equipment



Specifications

CONTACT RATING: B contact material: 0.4 VA max. @ 20 V AC or DC max. Q contact material: 5 AMPS @ 120 V AC or 28 V DC; 2 AMPS @ 250 V AC. See page G-20 for additional ratings.

ELECTRICAL LIFE: 7X01 and UX1 models: 100,000 make-and-break cycles at full load. All other models: 40,000 cycles.

CONTACT RESISTANCE: Below 10 m Ω typ. initial @ 2-4 V DC, 100 mA, for both silver and gold plated contacts.

INSULATION RESISTANCE: 10⁹ Ω min.

DIELECTRIC STRENGTH: 1000 Vrms min. @ sea level.

OPERATING TEMPERATURE: -30°C to 85°C.

SOLDERABILITY: Per MIL-STD-202F method 208D, or EIA RS-186E method 9 (1 hour steam aging).

NOTE: Any models supplied with S, P, R, Q, B or G contact material are RoHS compliant.

NOTE: Specifications and materials listed above are for switches with standard options. For information on specific and custom switches, consult Customer Service Center.

Materials

CASE: Glass filled nylon 6/6, flame retardant, heat stabilized, or diallyl phthalate (DAP) (UL 94V-0).

ACTUATOR: Nylon, black.

FRAME (FRONT MOUNT): Nylon, black.

FRAME (REAR MOUNT): Spring steel, black.

BUSHING: Brass or zinc, nickel plated.

HOUSING: Stainless steel.

SWITCH SUPPORT: Brass or steel, matte-tin plated.

END CONTACTS: B contact material: Copper alloy, with gold plate over nickel plate. Q contact material: Coin silver, silver plated. See page G-20 for additional contact materials.

CENTER CONTACTS & ALL TERMINALS: B contact material: Copper alloy, with gold plate over nickel plate. Q contact material: Copper alloy, silver plated. See page G-20 for additional contact materials.

TERMINAL SEAL: Epoxy. Refer to Soldering and Cleaning in Technical Data Section

HARDWARE: Mounting nuts & screws: Brass. Lockwasher: Stainless steel. Standoff: Nylon standard.

Build-A-Switch

To order, simply select desired option from each category and place in the appropriate box. Available options are shown and described on pages G-4 through G-24. For additional options not shown in catalog, consult Customer Service Center. All models have epoxy terminal seal and are compatible with all "bottom-wash" PCB cleaning methods.

| | | | |
|--|--|---|---|
| <p>Switch Function</p> <p>7101 SP On-None-On 7103 SP On-Off-On 7105 SP Mom.-Off-Mom. 7107 SP On-Off-Mom. 7108 SP On-None-Mom. 7109 SP None-On-Mom. 7201 DP On-None-On 7203 DP On-Off-On 7205 DP Mom.-Off-Mom. 7207 DP On-Off-Mom. 7208 DP On-None-Mom. 7211 DP On-On-On 7213 DP On-On-Mom. 7215 DP Mom.-On-Mom. 7301 3P On-None-On 7303 3P On-Off-On 7401 4P On-None-On 7405 4P Mom.-Off-Mom. 7411 4P On-On-On</p> <p>Note: UL models available, see pages G-5 and G-6.</p> | <p>Actuator</p> <p>J1 .531" long rocker J2 Lever J3 .906" long rocker J8 .699" long rocker J10 1.318" long rocker J11 Rocker with frame J15 Rocker, snap-in J16 Rocker with frame, snap-in J19 Rocker with frame J21 Lever with frame J25 Lever, snap-in J26 Lever with frame, snap-in J37 Rocker with frame J50 Rocker J51 Rocker with frame J52 Rocker with frame for LED, snap-in J60 Lever J61 Lever with frame, snap-in J62 Lever with frame for LED, snap-in J90 Lever J91 Lever with frame, snap-in</p> | <p>Terminations</p> <p>A Right angle, PC thru-hole AV2 Vertical right angle, PC thru-hole C PC Thru-hole Z Solder lug A3 Right angle, snap-in, PC thru-hole AV3 Vertical right angle, snap-in, PC thru-hole AW3 Right angle, extended, PC thru-hole V2 .555" high, V-bracket V3 .460" high, V-bracket V4 .630" high, V-bracket V5 Vertical right angle, PC thru-hole V6 .460" high, V-bracket V7 .630" high, V-bracket V8 .953" high, V-bracket V9 1.150" high, V-bracket V31 .460" high, V-bracket, snap-in V51 Vertical right angle, snap-in V61 .460" high, V-bracket, snap-in W .750" long, wire wrap W3 .425" long, wire wrap W5 1.305" long, wire wrap Z3 Quick connect</p> | <p>Contact Material</p> <p>B Gold P Gold, matte tin Q Silver S Silver, matte-tin G Gold over silver R Gold over silver, matte-tin</p> <p>Seal</p> <p>E Epoxy I Epoxy potted base</p> <p>Actuator Color</p> <p>2 Black 1 White 3 Red</p> <p>Frame Color</p> <p>2 Black NONE No frame color required 1 White</p> <p>Metal Frame Color (J11, J19, J21 & J37 Actuators) 2 Black 1 White</p> |
|--|--|---|---|



Dimensions are shown: Inches (mm)
 Specifications and dimensions subject to change



7000 Series Miniature Rocker & Lever Handle Switches

SWITCH FUNCTION

| NO. POLES | MODEL NO. | UL** MODEL NO. | SWITCH FUNCTION | | | CONNECTED TERMINALS | | | SCHEMATIC |
|---|--------------|----------------|-----------------|--------|--------|---------------------|---------|---------|-----------|
| | | | POS. 1 | POS. 2 | POS. 3 | POS. 1 | POS. 2 | POS. 3 | |
| SP | 7101 | U11 | ON | NONE | ON | 2-3 | N/A | 2-1 | |
| | 7103 | U13 | ON | OFF | ON | | N/A | | |
| | 7105 | U15 | MOM. | OFF | MOM. | | OPEN | | |
| | 7107 | U17 | ON | OFF | MOM. | | N/A | | |
| | 7108 | U18 | ON | NONE | MOM. | | N/A | | |
| | 7109 | U19 | NONE | ON | MOM. | | N/A | | |
| SPDT <p>Part number shown: 7101J1ZQE2</p> | | | | | | | | | |
| DP | 7201 | U21 | ON | NONE | ON | 2-3,5-6 | N/A | 2-1,5-4 | |
| | 7203 | U23 | ON | OFF | ON | | OPEN | | |
| | 7205 | U25 | MOM. | OFF | MOM. | | N/A | | |
| | 7207 | U27 | ON | OFF | MOM. | | N/A | | |
| | 7208 | U28 | ON | NONE | MOM. | | N/A | | |
| | 7211* | U211* | ON | ON | ON | | 2-3,5-4 | | |
| | 7213* | U213* | ON | ON | MOM. | | 2-3,5-4 | | |
| | 7215* | U215* | MOM. | ON | MOM. | | 2-3,5-4 | | |
| DPDT <p>Part number shown: 7201J1ZQE2</p> | | | | | | | | | |

MOM. = Momentary

* Wiring for 3-way switch, see Section N.

** U11 through U413 model nos. with all options when ordered with G, Q, R or S contact material.

Rocker

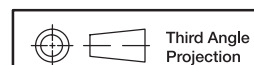

Dimensions are shown: Inches (mm)
Specifications and dimensions subject to change

www.ck-components.com

7000 Series Miniature Rocker & Lever Handle Switches

SWITCH FUNCTION

| NO. POLES | MODEL NO. | UL** MODEL NO. | SWITCH FUNCTION | | | CONNECTED TERMINALS | | | SCHEMATIC |
|-----------|-------------|----------------|-----------------|--------|--------|---------------------|--------|-------------|-----------|
| | | | POS. 1 | POS. 2 | POS. 3 | POS. 1 | POS. 2 | POS. 3 | |
| | | | | | | | | | |
| 3P | 7301 | U31 | ON | NONE | ON | 2-3-5-6,8-9 | N/A | 2-1,5-4,8-7 | 3PDT |
| | 7303 | U33 | ON | OFF | ON | 2-3-5-6,8-9 | OPEN | 2-1,5-4,8-7 | |

3PDT

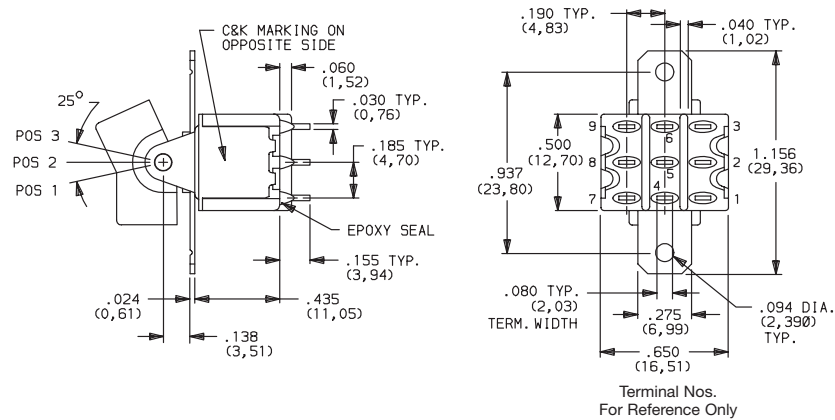

Part number shown: 7301J1ZQE2

| | | | | | | | | | |
|----|--------------|--------------|------|------|------|-------------------|-------------------|-------------------|----------|
| 4P | 7401 | U41 | ON | NONE | ON | 2-3-5-6,8-9,11-12 | N/A | 2-1,5-4,8-7,11-10 | 4PDT |
| | 7405 | U45 | MOM. | OFF | MOM. | | OPEN | | |
| | 7411* | U411* | ON | ON | ON | | 2-3-5-4,8-9,11-10 | | |

4PDT

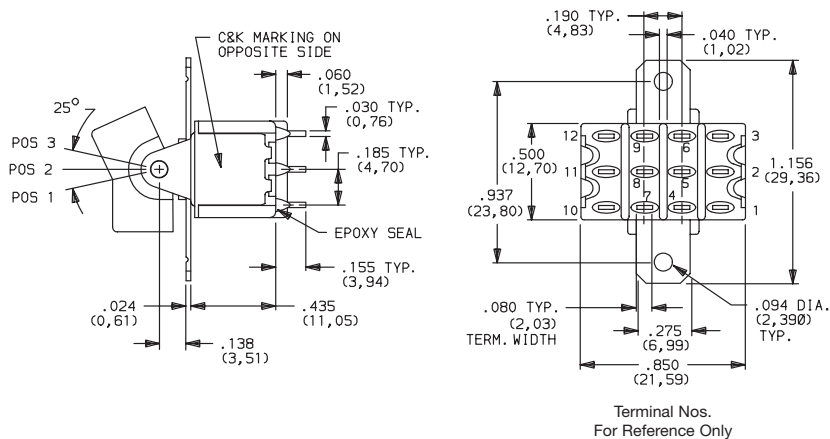

Part number shown: 7401J1ZQE2

MOM. = Momentary

** U11 through U411 model nos. with all options when ordered with G, Q, R or S contact material.

* Wiring for 3-way switch: See Technical Data section of this catalog for RoHS compliant and compatible definitions and specifications.



Dimensions are shown: Inches (mm)
Specifications and dimensions subject to change



7000 Series Miniature Rocker & Lever Handle Switches

ACTUATOR-PANEL REAR MOUNT

ACTUATOR COLOR

ACTUATOR

J1 ROCKER

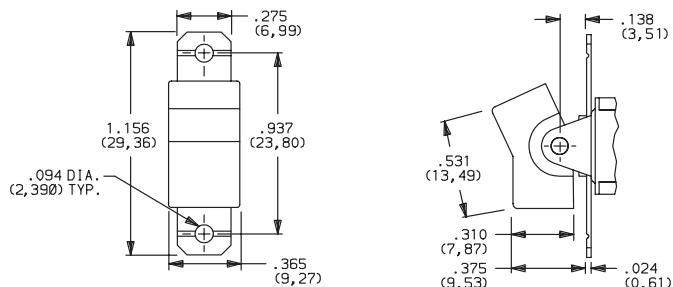

| OPTION CODE | ACTUATOR COLOR |
|-------------|----------------|
| 2 | BLACK |
| 1 | WHITE |
| 3 | RED |

Finish: Matte. Other colors, custom actuator markings and legends available, consult Customer Service Center.

NOTE: Hardware: two each—mounting screws, nuts, lockwashers and standoffs for 1/8 inch thick panel are supplied standard on all switches with panel mounting brackets. Actuators available separately, see page G-21 through G-22. Hardware is available see Technical Data section of this catalog.

J1, J2, J3, J8 & J10 Actuators available with C, W-W5, Z or Z3 terminations.

PANEL MOUNTING

J1 & J2 Actuators

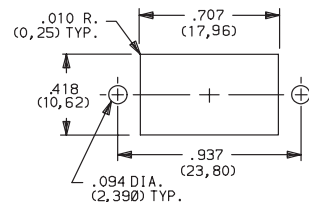

J3 Actuator

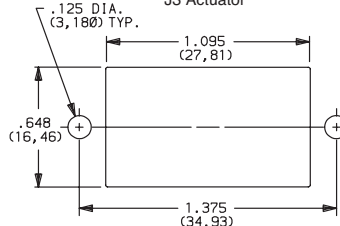

J8 Actuator

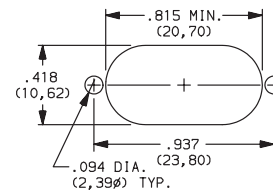

J3 ROCKER

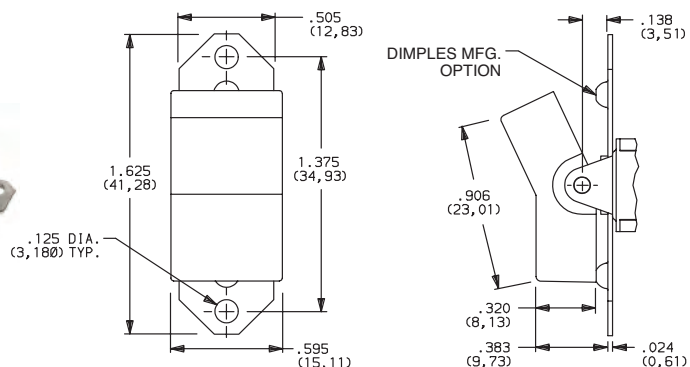

J8 ROCKER

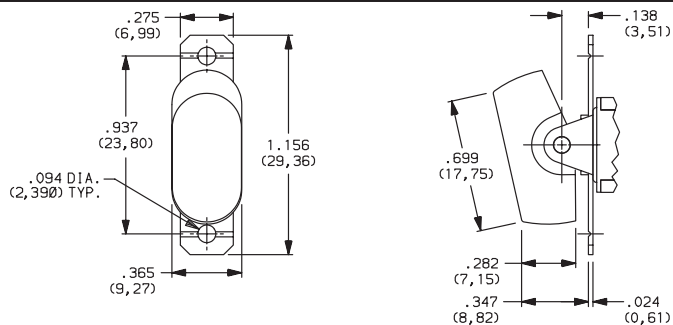

J10 ROCKER

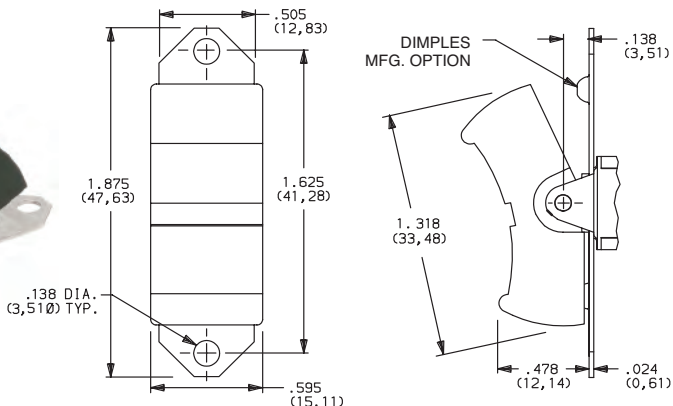

J10 Actuator

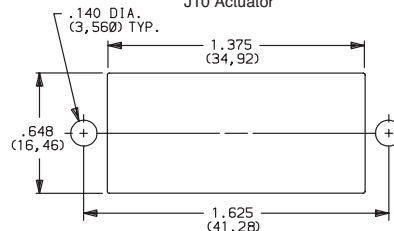

Rocker



G

C&K

Third Angle Projection

Dimensions are shown: Inches (mm)
Specifications and dimensions subject to change

www.ck-components.com

7000 Series Miniature Rocker & Lever Handle Switches

ACTUATOR-SNAP-IN FRONT MOUNT

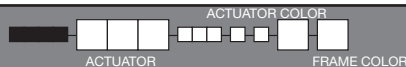

| OPTION CODE | ACTUATOR COLOR |
|-------------|----------------|
| 2 | BLACK |
| 1 | WHITE |
| 3 | RED |

| OPTION CODE | FRAME COLOR |
|-------------|------------------------------------|
| 2 | BLACK |
| NONE | No Frame Color (J15 or J25options) |
| 1 | WHITE |

Finish: Matte. Other colors, custom actuator markings and legends available, consult Customer Service Center.

NOTE: Actuators & frames available separately, see pages G-21 through G-22. J15, J16, J25, J26, J50 & J51 Actuators available with 71XX, 72XX, U1XX & U2XX models and C, W-W5, Z and Z3 terminations.

PANEL MOUNTING

J15, J16, J25 & J26 Actuators



J50 Actuator

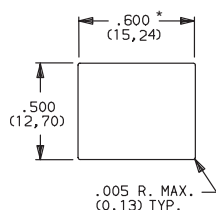

* For J50: Increase this dimension to .620/.625 (15,75/15,88) for .091/.125 (2,31/3,18) thk. panels.

J15 ROCKER, SNAP-IN



No frame color choice required

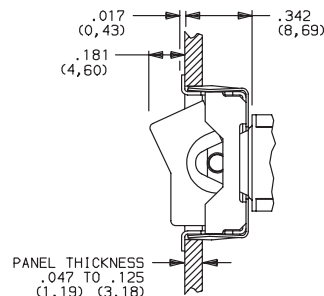

PANEL THICKNESS
.047 TO .125
(1,19) (3,18)



J16 ROCKER WITH FRAME, SNAP-IN

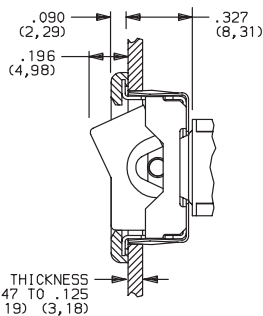
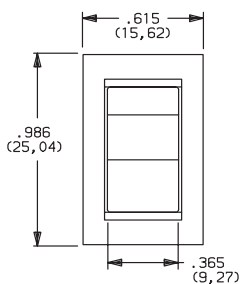

PANEL THICKNESS
.047 TO .125
(1,19) (3,18)



J25 LEVER, SNAP-IN

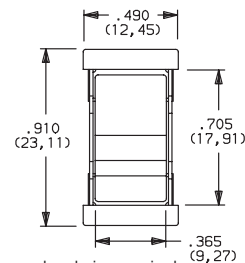

No frame color choice required

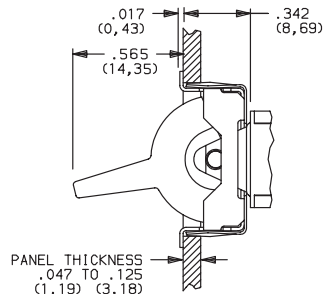

PANEL THICKNESS
.047 TO .125
(1,19) (3,18)



J26 LEVER WITH FRAME, SNAP-IN

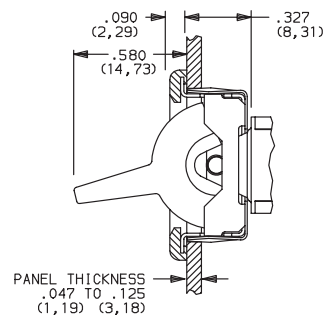
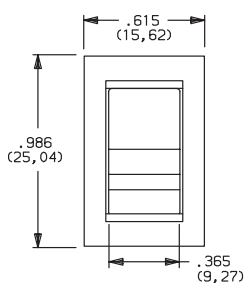

PANEL THICKNESS
.047 TO .125
(1,19) (3,18)



J50 ROCKER, SNAP-IN

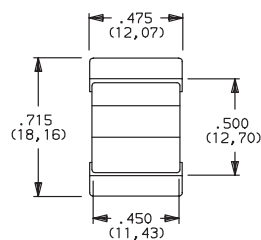

No frame color choice required

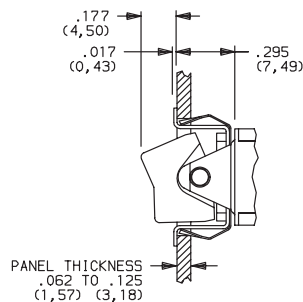

PANEL THICKNESS
.062 TO .125
(1,57) (3,18)



Third Angle
Projection

Dimensions are shown: Inches (mm)
Specifications and dimensions subject to change



7000 Series Miniature Rocker & Lever Handle Switches

ACTUATOR-SNAP-IN FRONT MOUNT

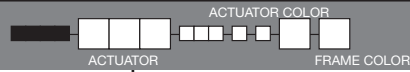

J51 ROCKER WITH FRAME, SNAP-IN

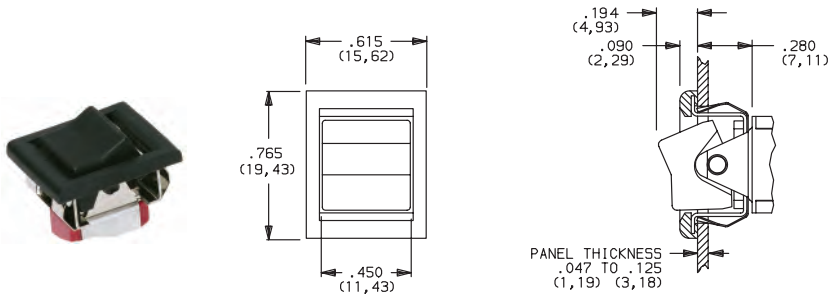

| OPTION CODE | ACTUATOR COLOR |
|-------------|----------------|
| 2 | BLACK |
| 1 | WHITE |
| 3 | RED |

J52 ROCKER WITH FRAME FOR LED, SNAP-IN



| OPTION CODE | FRAME COLOR |
|-------------|-------------------------------------|
| 2 | BLACK |
| NONE | No Frame Color (J15 or J25 options) |
| 1 | WHITE |

Finish: Matte. Other colors, custom actuator markings and legends available, consult Customer Service Center.

NOTE: Actuators & frames available separately, see pages G-21 through G-22. J51, J52, J60 & J61 Actuators available with 71XX, 72XX, U1XX & U2XX models and C, W-W5, Z and Z3 terminations.

LED not included.
For LED information, see page G-24.

J60 LEVER, SNAP-IN

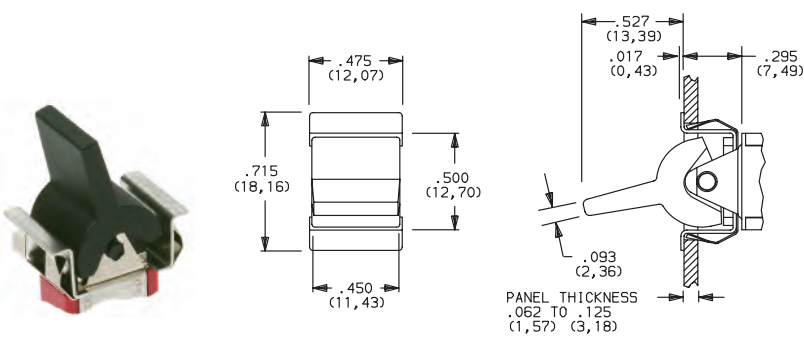

PANEL MOUNTING

J51, J60 & J61 Actuators



J52 Actuator

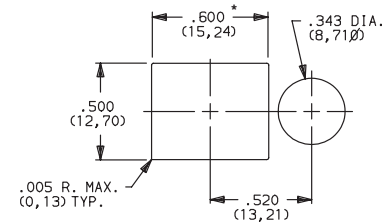

For J51, J52: Increase this dimension to .620/.625 (15,75/15,88) for .060/.125(1,52/3,18) thk. panels.

No frame color choice required

J61 LEVER WITH FRAME, SNAP-IN

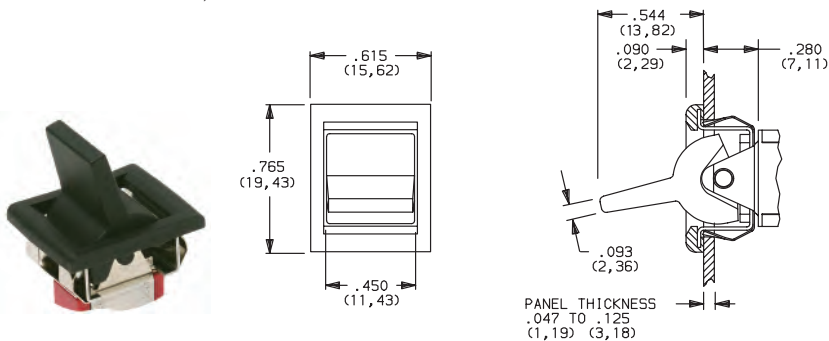

Rocker



G



Third Angle Projection

Dimensions are shown: Inches (mm)
Specifications and dimensions subject to change

www.ck-components.com

7000 Series Miniature Rocker & Lever Handle Switches

ACTUATOR-SNAP-IN FRONT MOUNT

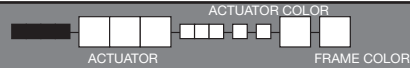

| OPTION CODE | ACTUATOR COLOR |
|-------------|----------------|
| 2 | BLACK |
| 1 | WHITE |
| 3 | RED |

| OPTION CODE | FRAME COLOR |
|-------------|------------------------------|
| 2 | BLACK |
| NONE | No Frame Color (J90 options) |
| 1 | WHITE |

Finish: Matte. Other colors, custom actuator markings and legends available, consult Customer Service Center.

NOTE: Actuators & frames available separately, see pages G-21 through G-22. J62, J90 & J91 Actuators available with 71XX, 72XX, U1XX & U2XX models and C, W-W5, Z & Z3 terminations.

PANEL MOUNTING

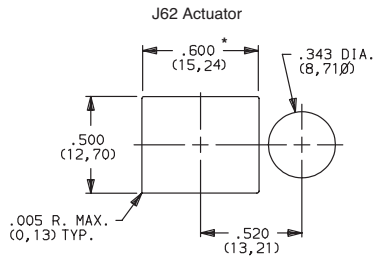

J90, J91 & J93 Actuators

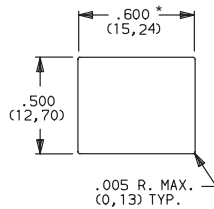

* For J90: Increase this dimension to .620/.625 (15,75/15,88) for .091/.125 (2,31/3,18) thk. panels.
For J91: Increase this dimension to .620/.625 (15,75/15,88) for .060/.125 (1,52/3,18) thk. panels.

J62 LEVER WITH FRAME FOR LED, SNAP-IN

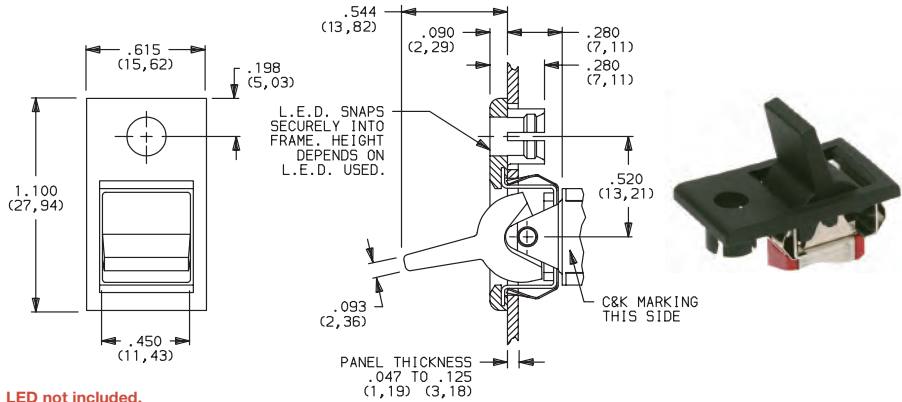

LED not included.
For LED information, see page H-25.

J90 LEVER, SNAP-IN

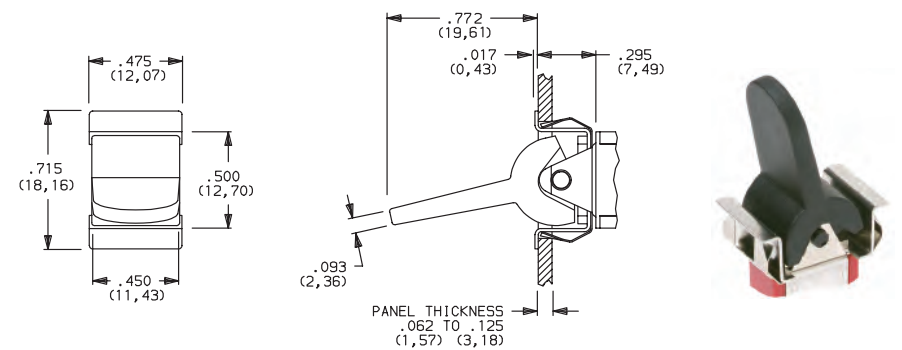

No frame color choice required.

J91 LEVER WITH FRAME, SNAP-IN

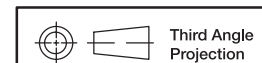
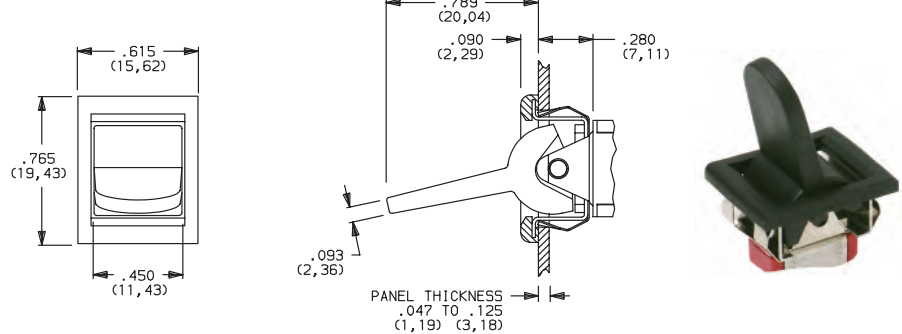

Dimensions are shown: Inches (mm)
Specifications and dimensions subject to change

www.ck-components.com



7000 Series Miniature Rocker & Lever Handle Switches

ACTUATOR-REAR MOUNT

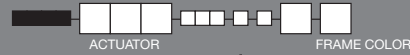

J11 ROCKER WITH FRAME

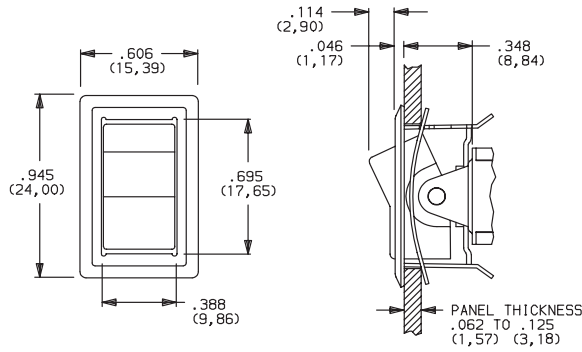

| OPTION CODE | ACTUATOR COLOR |
|-------------|----------------|
| 2 | BLACK |
| 1 | WHITE |
| 3 | RED |

| OPTION CODE | FRAME COLOR |
|-------------|-------------|
| 2 | BLACK |
| 1 | WHITE |

Actuator finish: Matte. Frame finish: Gloss. Other colors, custom actuator markings and legends available, consult Customer Service Center.

NOTE: Actuators & frames available separately, see pages G-21 through G-22. J11, J19, J21 & J37 Actuators available with C, W-W5, Z & Z3 terminations.

J19 ROCKER WITH FRAME

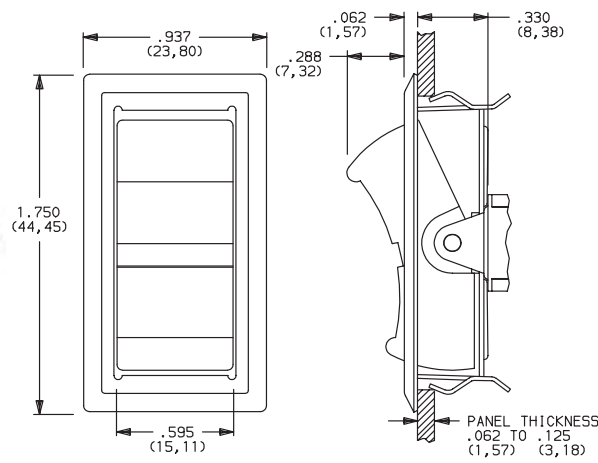

PANEL MOUNTING

J11 & J21 Actuators

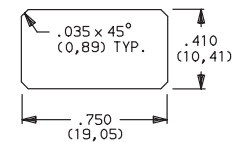

J19 Actuator

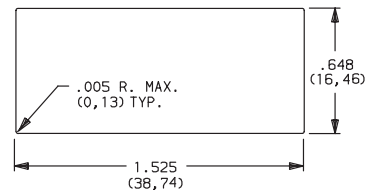

J37 Actuator

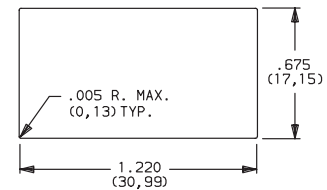

J21 LEVER WITH FRAME

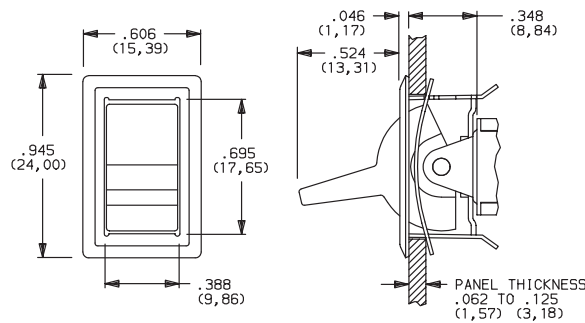

J37 ROCKER WITH FRAME

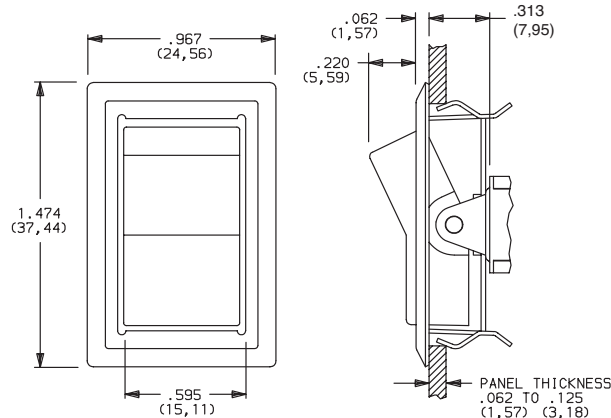

Rocker



G

C&K



Third Angle Projection

Dimensions are shown: Inches (mm)
 Specifications and dimensions subject to change

www.ck-components.com

7000 Series Miniature Rocker & Lever Handle Switches

ACTUATOR-PC MOUNT



| OPTION CODE | ACTUATOR COLOR |
|-------------|----------------|
| 2 | BLACK |
| 1 | WHITE |
| 3 | RED |

Finish: Matte. Other colors, custom actuator markings and legends available, consult Customer Service Center.

NOTE: Some permissible actuator/termination combinations may lack clearance between actuator and PC board, and care must be exercised to accommodate this condition.

Actuators available separately, see page G-21 through G-22. J1, J2 & J8 actuators available with A, A3, AV2, AV3, AW3 & V2 terminations. J3 actuators available with AV2, AV3 & V2-V61 terminations. J50 actuators available with A (DP, 3P models only), A3 (DP, 3P models only), AV2, AV3, AW3 (DP, 3P models only) & V2-V61 terminations.

J1 ROCKER

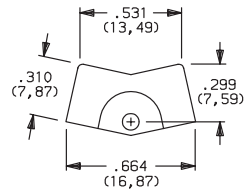

J2 LEVER

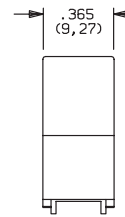
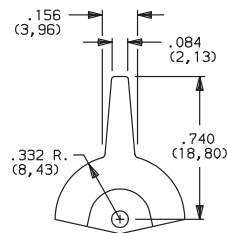

J3 ROCKER

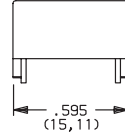
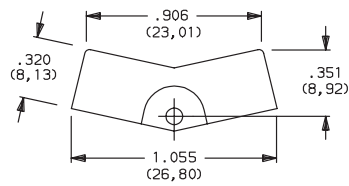

J8 ROCKER

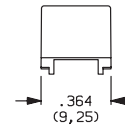
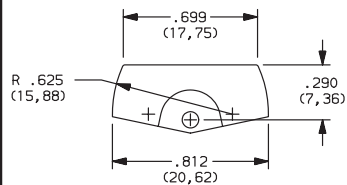

J50 ROCKER

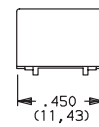
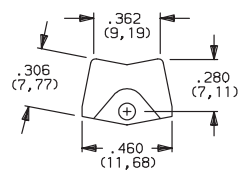

Rocker



Third Angle Projection
Dimensions are shown: Inches (mm)
Specifications and dimensions subject to change



7000 Series Miniature Rocker & Lever Handle Switches

ACTUATOR-PC MOUNT



J60 LEVER



| OPTION CODE | ACTUATOR COLOR |
|-------------|----------------|
| 2 | BLACK |
| 1 | WHITE |
| 3 | RED |

Finish: Matte. Other colors, custom actuator markings and legends available, consult Customer Service Center.

NOTE: Some permissible actuator/termination combinations may lack clearance between actuator and PC board, and care must be exercised to accommodate this condition.

J90 LEVER



Actuators available separately, see page G-21 through G-22. J60 & J90 actuators available with A (DP, 3P models only), A3 (DP, 3P models only), AV2, AV3, AW3 (DP, 3P models only) & V2-V61 terminations.

TERMINATIONS



Z SOLDER LUG

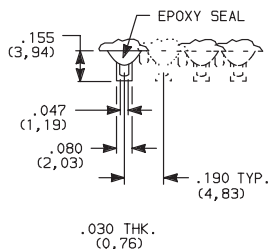

SPDT thru 4PDT

Not available with P, R or S contact materials. Available actuators, see pages G-7 through G-13.

C PC THRU-HOLE

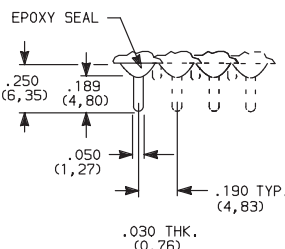

PC MOUNTING

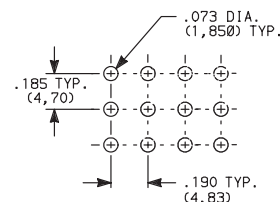

SPDT thru 4PDT

NOTE: Available actuators, see pages G-7 through G-13.

Z3 QUICK CONNECT

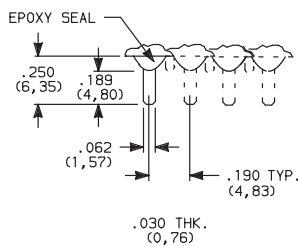

SPDT thru 4PDT

Not available with P, R or S contact materials. Available actuators, see pages G-7 through G-13. Mating quick connector available; order part number 530100000, page G-22.

W, W3, W5 WIRE WRAP

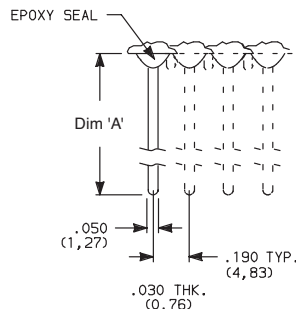

| OPTION CODE | DIM 'A' |
|-------------|---------------|
| W | .750 (19,05) |
| W3 | .425 (10,80) |
| W5 | 1.305 (33,15) |

SPDT thru 4PDT

NOTE: Available actuators, see pages G-7 through G-13.



Third Angle Projection

Dimensions are shown: Inches (mm)
Specifications and dimensions subject to change

www.ck-components.com

Rocker



G

C&K

7000 Series Miniature Rocker & Lever Handle Switches

TERMINATIONS

A RIGHT ANGLE, PC THRU-HOLE



7101J1ABE2
Horizontal Actuation
SPDT

A3 RIGHT ANGLE, SNAP-IN, PC THRU-HOLE

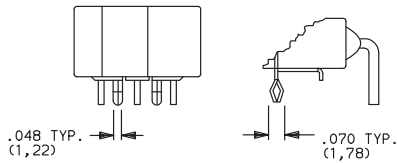

AW3 RIGHT ANGLE, EXTENDED, PC THRU-HOLE

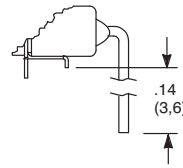

PC MOUNTING



Not available with I seal option. Available actuators, see pages G-6 and G-12.
Terminal bend radii and lead-in manufacturing option.

NOTE: PC pattern must clear switch support leg.

A RIGHT ANGLE, PC THRU-HOLE



7201J1ABE2
Horizontal Actuation
DPDT

A3 RIGHT ANGLE, SNAP-IN, PC THRU-HOLE

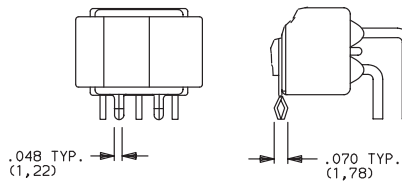

PC MOUNTING

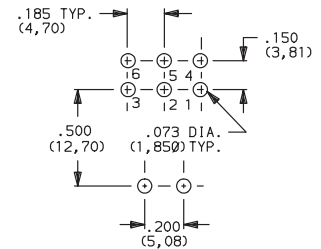

Not available with I seal option. Available actuators, see pages G-6 and G-12.
Terminal bend radii and lead-in manufacturing option.

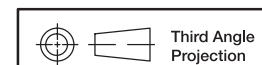

Dimensions are shown: Inches (mm)
Specifications and dimensions subject to change



7000 Series Miniature Rocker & Lever Handle Switches

TERMINATIONS

A RIGHT ANGLE, PC THRU-HOLE



7301J1ABE2
Horizontal Actuation
3PDT

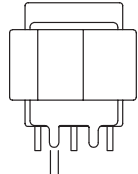

Actuator Shown In Pos. 1

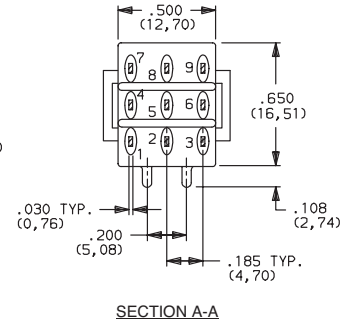
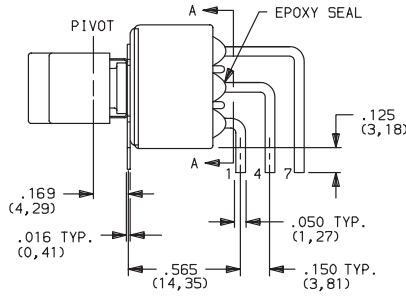

Not available with I seal option. Available actuators, see pages G-6 and G-12.
Terminal bend radii and lead-in manufacturing option.

AV2 VERTICAL RIGHT ANGLE, PC THRU-HOLE,
.150" PITCH



7101J1AV2BE2
Vertical Actuation
SPDT

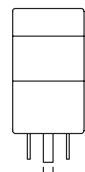

Actuator Shown In Pos. 1

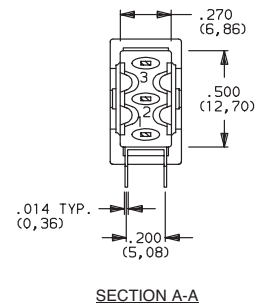
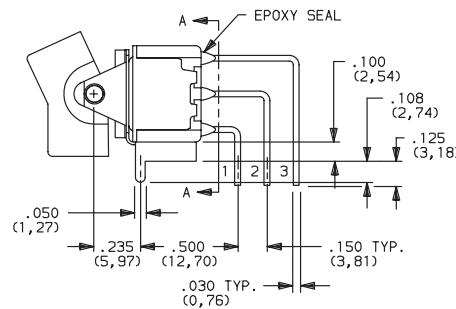

AV3 VERTICAL RIGHT ANGLE, SNAP-IN, PC THRU-HOLE,
.150" PITCH

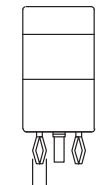

.070 TYP. (1,78)

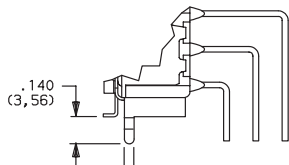

.140 (3,56)

.048 TYP. (1,22)

Rocker

Not available with I seal option. Available actuators, see pages G-6 and G-12.
Terminal bend radii and lead-in manufacturing option.



G



PC MOUNTING

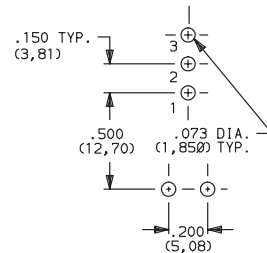

Third Angle Projection

Dimensions are shown: Inches (mm)
Specifications and dimensions subject to change

www.ck-components.com

7000 Series Miniature Rocker & Lever Handle Switches

TERMINATIONS

AV2 VERTICAL RIGHT ANGLE, PC THRU-HOLE,
.150" PITCH



Actuator Shown In Pos. 1

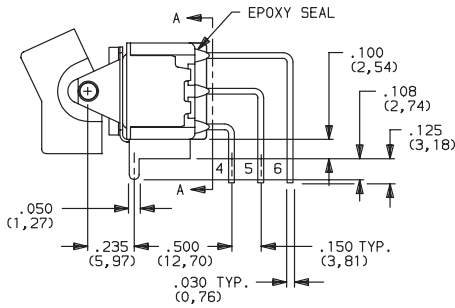

7201J1AV2BE2
Vertical Actuation
DPDT

AV3 VERTICAL RIGHT ANGLE, SNAP-IN, PC THRU-HOLE,
.150" PITCH

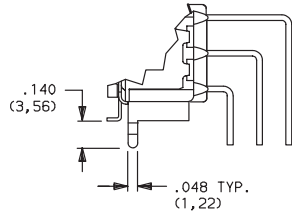

PC MOUNTING

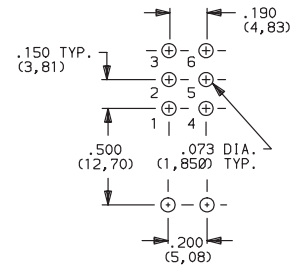

Not available with I seal option. Available actuators, see pages G-6 and G-12.
Terminal bend radii and lead-in manufacturing option.

AV2 VERTICAL RIGHT ANGLE, PC THRU-HOLE,
.150" PITCH

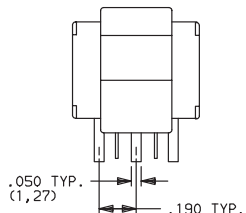

Actuator Shown In Pos. 1

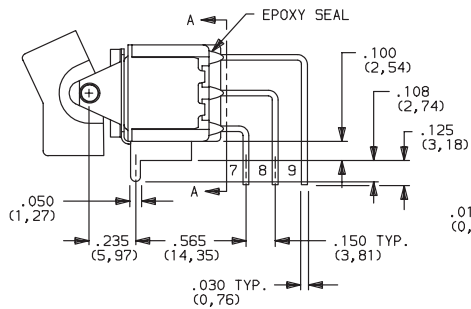

7301J1AV2BE2
Vertical Actuation
3PDT

AV3 VERTICAL RIGHT ANGLE, SNAP-IN, PC THRU-HOLE,
.150" PITCH

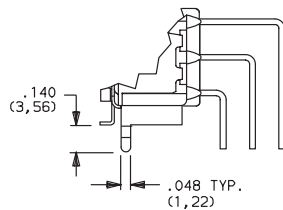

PC MOUNTING

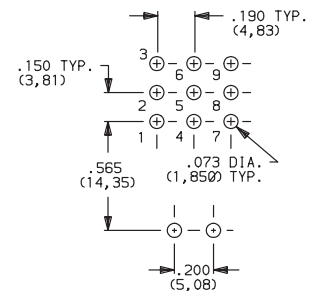

Not available with I seal option. Available actuators, see pages G-6 and G-12.
Terminal bend radii and lead-in manufacturing option.



7000 Series Miniature Rocker & Lever Handle Switches

TERMINATIONS

AV2 VERTICAL RIGHT ANGLE, PC THRU-HOLE,
.150" PITCH



7401J1AV2BE2
Vertical Actuation
4PDT

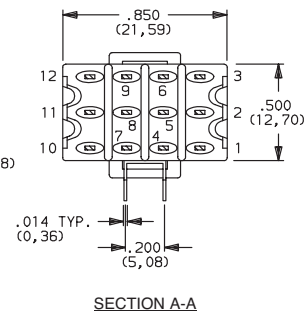
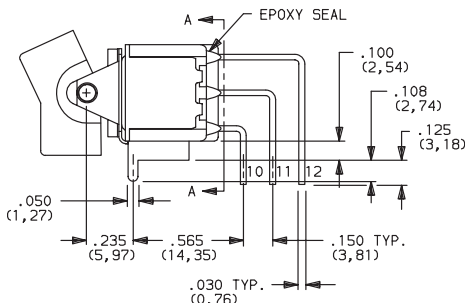

AV3 VERTICAL RIGHT ANGLE, SNAP-IN, PC THRU-HOLE,
.150" PITCH

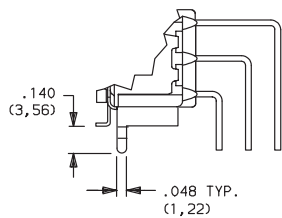
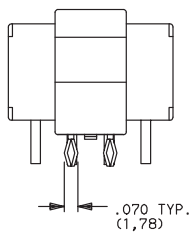

PC MOUNTING

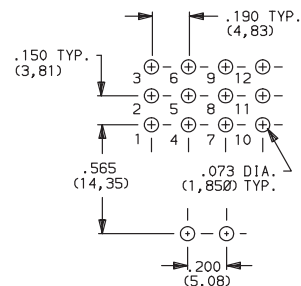

Not available with I seal option. Available actuators, see pages G-6 and G-12.
Terminal bend radii and lead-in manufacturing option.

V5 VERTICAL RIGHT ANGLE, PC THRU-HOLE,
.150" PITCH



7101J1V5BE2
Vertical Actuation
SPDT

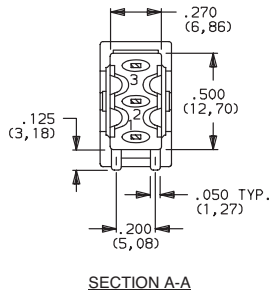
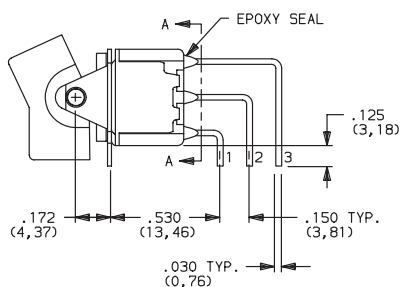
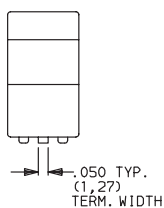

V51 VERTICAL RIGHT ANGLE, SNAP-IN,
PC THRU-HOLE, .150" PITCH

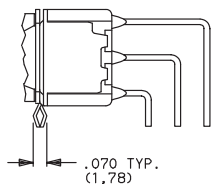
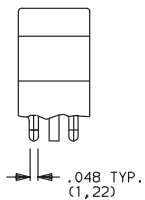

PC MOUNTING

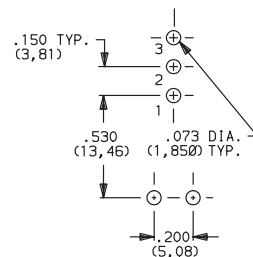

Not available with I seal option. Available actuators, see pages G-6 and G-12.
Terminal bend radii and lead-in manufacturing option.

Rocker



G

C&K



Dimensions are shown: Inches (mm)
Specifications and dimensions subject to change

7000 Series Miniature Rocker & Lever Handle Switches

TERMINATIONS

V5 VERTICAL RIGHT ANGLE, PC THRU-HOLE,
.150" PITCH

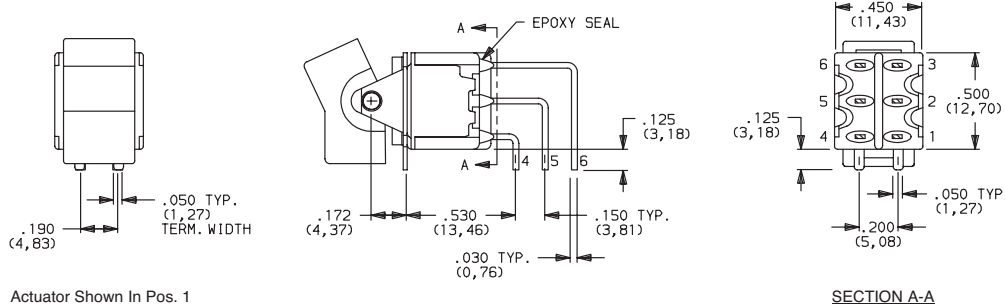

Actuator Shown In Pos. 1



7201J1V5BE2
Vertical Actuation
DPDT

V51 VERTICAL RIGHT ANGLE, SNAP-IN,
PC THRU-HOLE, .150" PITCH

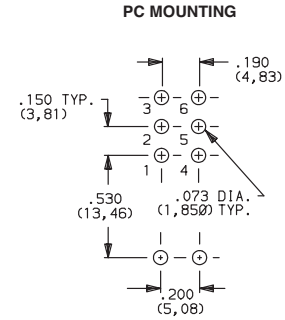
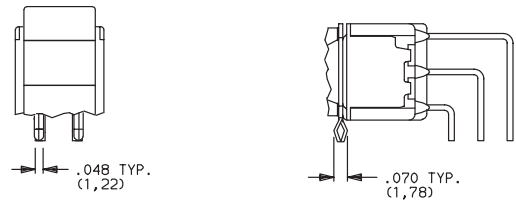

Not available with I seal option. Available actuators, see pages G-6 and G-12.
Terminal bend radii and lead-in manufacturing option.

V2, V6, V7, V8 VERTICAL MOUNT, V-BRACKET

V61 VERTICAL MOUNT, V-BRACKET, SNAP-IN

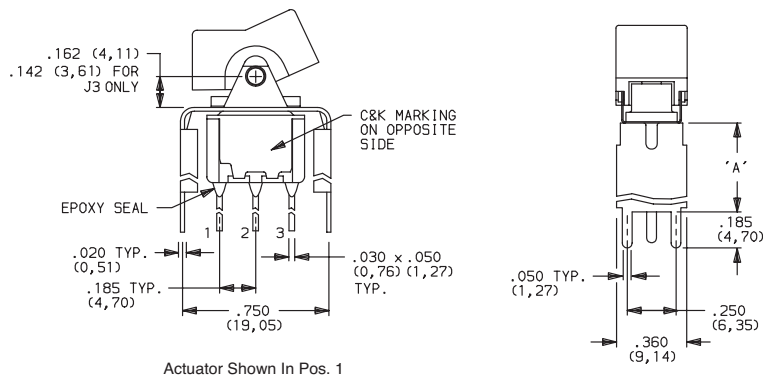

Actuator Shown In Pos. 1

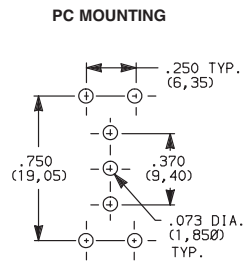

7101J1_BE2
SPDT

| OPTION CODE | DIM 'A' |
|----------------|--------------|
| V2, V21 | .555 (14,10) |
| V6, V61 | .460 (11,68) |
| V7 | .630 (16,00) |
| V8 | .953 (24,21) |

Not available with I seal option.
Available actuators, see pages G-6 and G-12.



7000 Series Miniature Rocker & Lever Handle Switches

TERMINATIONS

V2, V6, V7, V8 VERTICAL MOUNT, V-BRACKET

V21, V61 VERTICAL MOUNT, V-BRACKET, SNAP-IN

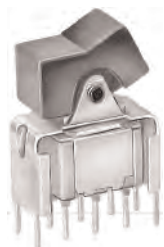

7201J1_BE2
DPDT

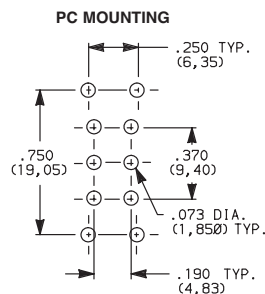
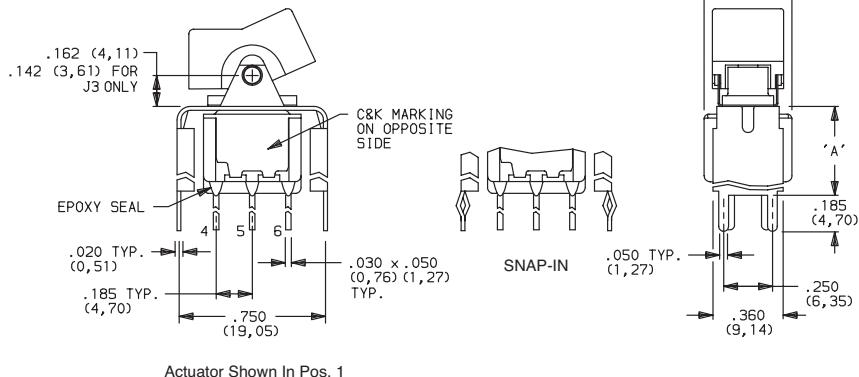

| OPTION CODE | DIM 'A' |
|----------------|--------------|
| V2, V21 | .555 (14,10) |
| V6, V61 | .460 (11,68) |
| V7 | .630 (16,00) |
| V8 | .953 (24,21) |

Not available with I seal option.
Available actuators, see pages G-6 and G-12.

V2, V7, V8 VERTICAL MOUNT, V-BRACKET

V21 VERTICAL MOUNT, V-BRACKET, SNAP-IN



7301J1_BE2
3PDT

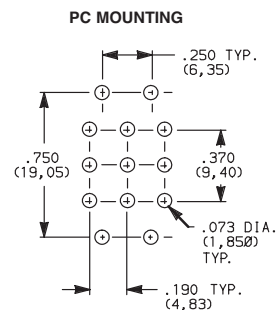
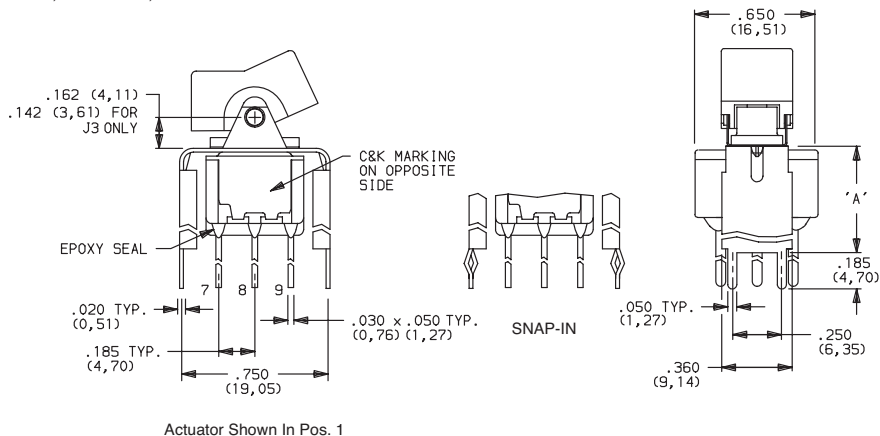

| OPTION CODE | DIM 'A' |
|----------------|--------------|
| V2, V21 | .555 (14,10) |
| V7 | .630 (16,00) |
| V8 | .953 (24,21) |

Not available with I seal option.
Available actuators, see pages G-6 and G-12.

V2, V7, V8 VERTICAL MOUNT, V-BRACKET

V21 VERTICAL MOUNT, V-BRACKET, SNAP-IN



7401J1_BE2
4PDT

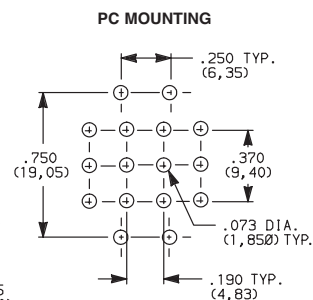
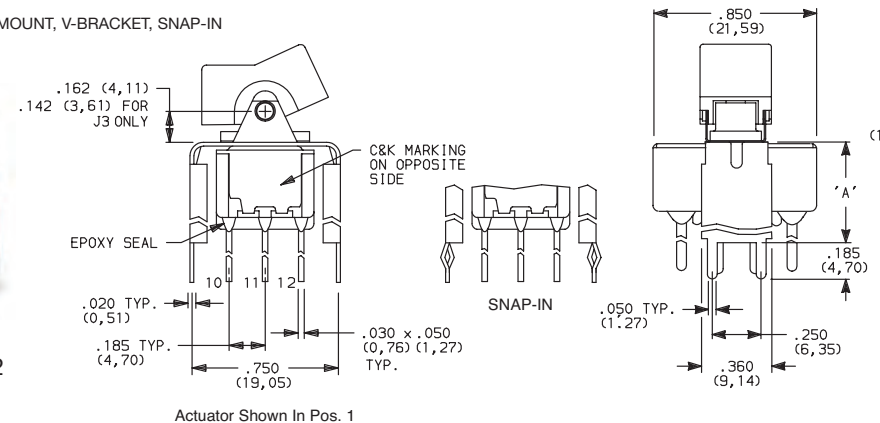

| OPTION CODE | DIM 'A' |
|----------------|--------------|
| V2, V21 | .555 (14,10) |
| V7 | .630 (16,00) |
| V8 | .953 (24,21) |

Not available with I seal option.
Available actuators, see pages G-6 and G-12.

Rocker



G

C&K



Dimensions are shown: Inches (mm)
Specifications and dimensions subject to change

7000 Series Miniature Rocker & Lever Handle Switches

TERMINATIONS

V3, V4, V9 VERTICAL MOUNT, V-BRACKET

V31 VERTICAL MOUNT, V-BRACKET, SNAP-IN

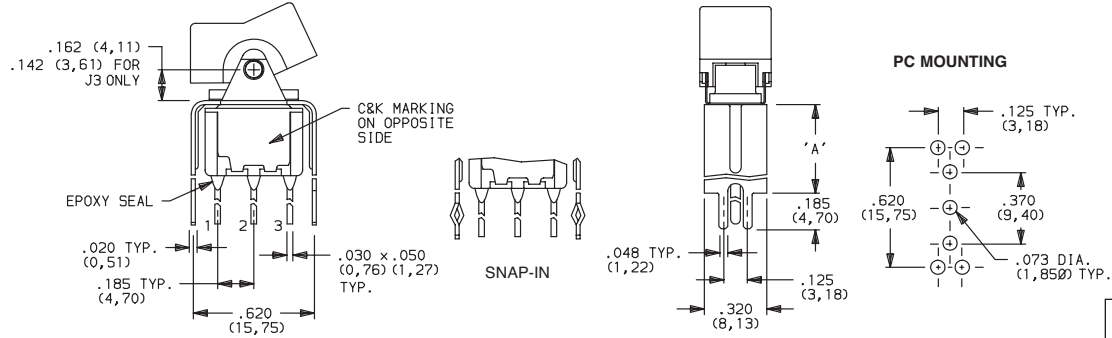

7101J1_BE2
SPDT

| OPTION CODE | DIM 'A' |
|----------------|---------------|
| V3, V31 | .460 (11,68) |
| V4 | .630 (16,00) |
| V9 | 1.150 (29,21) |

Not available with I seal option.
Available actuators, see pages G-6 and G-12.

Actuator Shown In Pos. 1

V3, V4, V9 VERTICAL MOUNT, V-BRACKET

V31 VERTICAL MOUNT, V-BRACKET, SNAP-IN

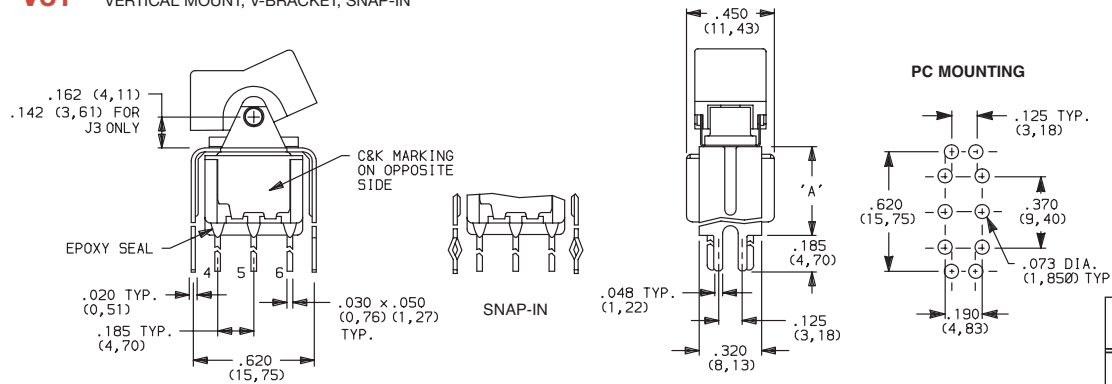

7201J1_BE2
DPDT

| OPTION CODE | DIM 'A' |
|----------------|---------------|
| V3, V31 | .460 (11,68) |
| V4 | .630 (16,00) |
| V9 | 1.150 (29,21) |

Not available with I seal option.
Available actuators, see pages G-6 and G-12.

Actuator Shown In Pos. 1

V4, V9 VERTICAL MOUNT, V-BRACKET

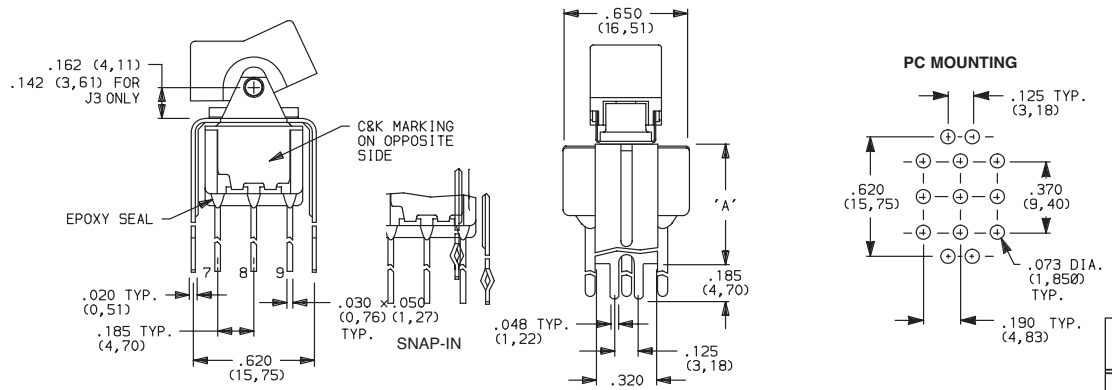

7301J1_BE2
3PDT

| OPTION CODE | DIM 'A' |
|-------------|---------------|
| V4 | .630 (16,00) |
| V9 | 1.150 (29,21) |

Not available with I seal option.
Available actuators, see pages G-6 and G-12.

Actuator Shown In Pos. 1



Dimensions are shown: Inches (mm)
Specifications and dimensions subject to change



7000 Series Miniature Rocker & Lever Handle Switches

TERMINATIONS

V4, V9 VERTICAL MOUNT, V-BRACKET



7401J1_BE2
4PDT

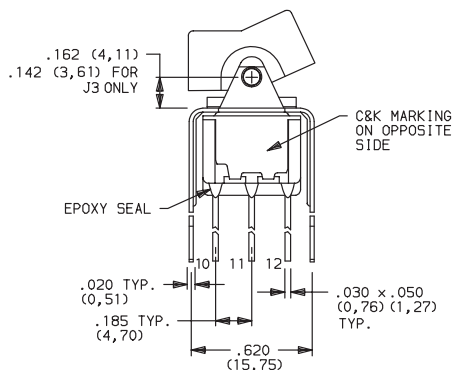

Actuator Shown In Pos. 1

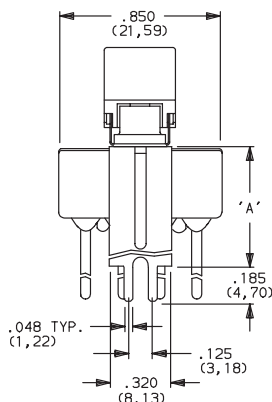
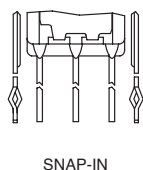

PC MOUNTING

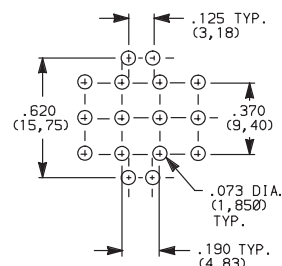

| OPTION CODE | DIM 'A' |
|-------------|---------------|
| V4 | .630 (16,00) |
| V9 | 1.150 (29,21) |

Not available with I seal option.
Available actuators, see pages G-6 and G-12.

CONTACT MATERIAL

| OPTION CODE | CONTACT MATERIAL | TERMINAL PLATING | RATINGS | |
|-------------|---------------------------------|------------------------|-----------------------------------|--|
| | | | | |
| B | GOLD ¹ | GOLD ¹ | LOW LEVEL/ DRY CIRCUIT | 0.4 VA MAX. @ 20 V AC OR DC MAX. |
| P | | MATTE-TIN ⁶ | | |
| Q | SILVER ^{4,5} | SILVER ⁵ | POWER | 5 AMPS @ 120 V AC OR 28 V DC; 2 AMPS @ 250 V AC. |
| S | | MATTE-TIN ⁶ | | |
| G | GOLD OVER SILVER ^{2,3} | GOLD ³ | LOW LEVEL/DRY CIRCUIT OR POWER | 0.4 VA MAX @ 20 V AC OR DC MAX OR 5 AMPS @ 120 V AC OR 28 V DC; 2 AMPS @ 250 V AC. |
| R | | MATTE-TIN ⁶ | | |

* Note: See Technical Data section of this catalog for RoHS compliant and compatible definitions and specifications.

- CONTACTS & TERMINALS: Copper alloy, with gold plate over nickel plate.
- END CONTACTS: Coin silver, with gold plate over nickel plate.
- CENTER CONTACTS & ALL TERMINALS: Copper alloy, with gold plate over nickel plate.
- END CONTACTS: Coin silver, silver plated.
- CENTER CONTACT & ALL TERMINALS: Copper alloy, silver plated.
- TERMINALS: Copper alloy, with matte-tin over nickel plate.

U11-U415 model numbers with all options when ordered with G, Q, S & R contact material.

B contact material standard with all terminations except C, Z & Z3.

Q contact material standard with C, Z & Z3 terminations.

P, S & R, contact materials not available with Z & Z3 terminations.

NOTE: Any models supplied with Q, B, G S, P & R contact material are RoHS compliant.

SEAL

E EPOXY SEAL

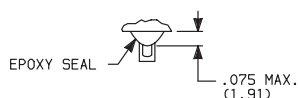

I EPOXY POTTED BASE

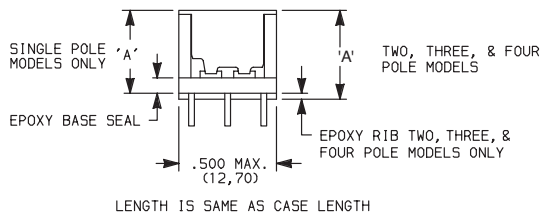

Available with C, W through W5, Z & Z3 terminations.

| NO. POLES | DIM 'A' |
|-----------|--------------|
| SP | .410 (10,41) |
| DP | .440 (11,18) |
| 3P | .505 (12,83) |
| 4P | .505 (12,83) |



Dimensions are shown: Inches (mm)
Specifications and dimensions subject to change

Rocker



G

C&K

7000 Series Miniature Rocker & Lever Handle Switches

AVAILABLE HARDWARE

Panel mounting hardware for rocker and lever handle switches is available separately. Mounting hardware consists of two screws, two nuts, two standoffs and two lockwashers per switch, and is available for panel thicknesses of 1/16, 3/32 and 1/8 inch. See part numbers below.

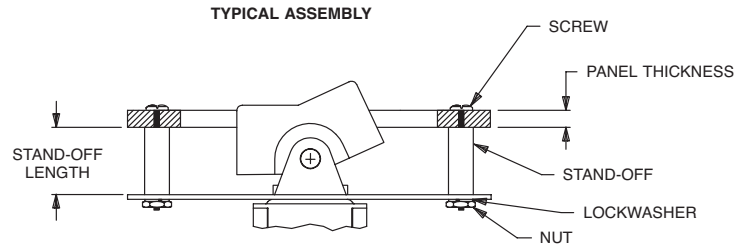

| Qty | Part Number | Description |
|-----|-------------|-----------------|
| 2 | 761103000 | Standoffs |
| 2 | 764100000 | Mounting screws |
| 2 | 764200000 | Lock washers |
| 2 | 764300000 | Hex nuts |

J1 & J2 actuators

| PART NO. | PANEL THK. | STANDOFF LENGTH |
|-----------|----------------|-----------------|
| 761103000 | 1/8 IN. (3,18) | .233 (5,92) |

J3 actuators

| PART NO. | PANEL THK. | STANDOFF LENGTH |
|-----------|----------------|-----------------|
| 770603000 | 1/8 IN. (3,18) | .233 (5,92) |

J10 actuators

| PART NO. | PANEL THK. | STANDOFF LENGTH |
|-----------|----------------|-----------------|
| 770703000 | 1/8 IN. (3,18) | .233 (5,92) |

MATERIAL

Screws, nuts, lockwashers: Stainless steel. Standoffs: Nylon, standard.

J1, J11, J15 & J16 Actuators



PART NO.
776A01000 WHITE
776A02263 BLACK
776A03000 RED

Material: Nylon
 Finish: Matte

J2, J21, J25 & J26 Actuators



PART NO.
426D01000 WHITE
426D02263 BLACK
426D03000 RED

Material: Nylon
 Finish: Matte

J3 & J37 Actuators



PART NO.
431D01000 WHITE
431D02263 BLACK
431D03000 RED

Material: Nylon
 Finish: Matte

J50, J51 & J52 Actuators



PART NO.
775A01000 WHITE
775A02263 BLACK
775A03000 RED

Material: Nylon
 Finish: Matte

J60, J61 & J62 Actuators



PART NO.
598101000 WHITE
613802263 BLACK
598103000 RED

Material: Nylon
 Finish: Matte

J8 Actuator



PART NO.
488701000 WHITE
488702263 BLACK
488703000 RED

Material: Nylon
 Finish: Matte



*Dimensions are shown: Inches (mm)
 Specifications and dimensions subject to change*



7000 Series Miniature Rocker & Lever Handle Switches

AVAILABLE HARDWARE

J90 & J91 Actuators



PART NO.
598001000 WHITE
598002263 BLACK
598003000 RED
 Material: Nylon
 Finish: Matte

J10 & J19 Actuators



PART NO.
769501000 WHITE
769502263 BLACK
769503000 RED
 Material: Nylon
 Finish: Matte

Fits Z3 Termination female connector



PART NO.
530100000
 Available in loose pieces.

Frame for J11 & J21 Actuators



PART NO.
764500746 BLACK ENAMEL
764500747 WHITE ENAMEL
764601106 RETAINING SPRING
 Material: Spring Steel

Frame for J16 & J26 Actuators



PART NO.
459101000 WHITE
459102000 BLACK
459103000 RED
 Material: Nylon
 Finish: Matte

Frame for J51, J61 & J91 Actuators



PART NO.
615601000 WHITE
615602263 BLACK
615603000 RED
 Material: Nylon
 Finish: Matte

Frame for J19 Actuator



PART NO.
781000746 BLACK ENAMEL
781000747 WHITE ENAMEL
 Material: Spring Steel

Frame for J37 Actuator



PART NO.
445400746 BLACK ENAMEL
445400747 WHITE ENAMEL
 Material: Spring Steel

Frame for J52 & J62 Actuators



PART NO.
613301000 WHITE
613302263 BLACK
613303000 RED
 Material: Nylon
 Finish: Matte

Rocker



G



Dimensions are shown: Inches (mm)
 Specifications and dimensions subject to change

7000 Series Miniature Rocker & Lever Handle Switches

AVAILABLE HARDWARE

Frames snap into panel opening and are independent from switch mounting. Accurate positioning of the PC mounted switch relative to the panel opening is necessary to provide proper clearance between actuator and frame. Available in two basic styles and four panel thicknesses .047-.125 in. Material: Nylon. Finish: Matte.

TYPICAL APPLICATION

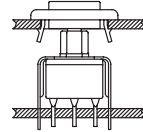

J1 & J2 Actuators

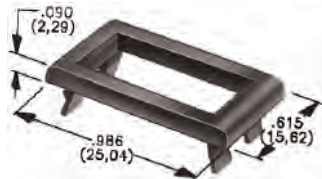

| .047" (1,19) PANEL THK. | .062" (1,57) PANEL THK. | .090" (2,29) PANEL THK. | .125" (3,18) PANEL THK. |
|------------------------------|------------------------------|------------------------------|------------------------------------|
| PART NO. 452902263 | PART NO. 452702263 | PART NO. 452802263 | PART NO. 452602263 BLACK |

J50, J60 & J90 Actuators



| .047" (1,19) PANEL THK. | .062" (1,57) PANEL THK. | .090" (2,29) PANEL THK. | .125" (3,18) PANEL THK. |
|------------------------------|------------------------------|------------------------------|------------------------------------|
| PART NO. 432502263 | PART NO. 432602263 | PART NO. 432702263 | PART NO. 432802263 BLACK |

PANEL MOUNTING

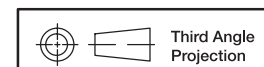
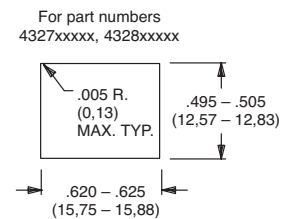
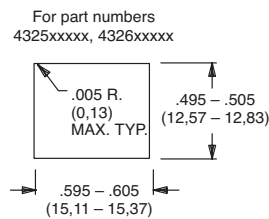
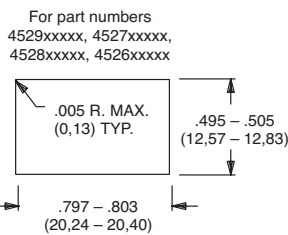

Dimensions are shown: Inches (mm)
Specifications and dimensions subject to change

www.ck-components.com



7000 Series Miniature Rocker & Lever Handle Switches

AVAILABLE HARDWARE

Panel Inserts

Will fit Separate Snap-in frames for J50, J60 & J90 actuators

Above frames (part nos. 432XXXXXX) are also available with insert which accepts LED for indicator light assembly. Order insert separately from frame. Blank insert panel (without hole for LED) also available. **LED not included.**

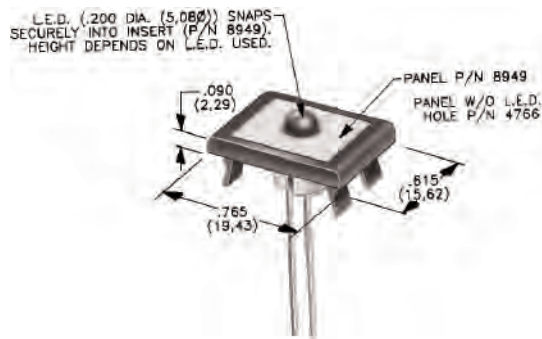

PANEL INSERT WITH HOLE FOR LED

PART NO.
894902000

BLANK PANEL INSERT WITHOUT HOLE FOR LED

PART NO.
476602000 BLACK

NOTE: Special colors, custom markings available, consult Customer Service Center.

LED INFORMATION

Process Information: Soldering to LED leads must be completed within 5 seconds at 500° F (260°C) maximum.

LEDs are not supplied with J52, J62 options. LED snaps into switch frame surrounding actuator and is wired externally.

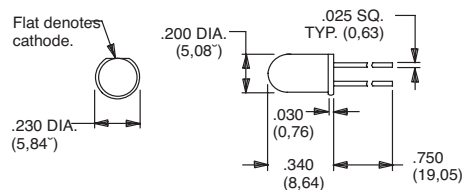

Suggested LED for J52 & J62 options.
Dimensions for reference only.

Rocker

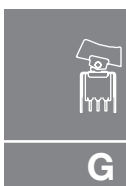

Third Angle Projection
Dimensions are shown: Inches (mm)
Specifications and dimensions subject to change

E Series

Sealed Miniature Rocker and Lever Handle Switches

Features/Benefits

- Sealed against solder and cleaning process contaminants
- ESD Resistance—all actuator options
- Rocker, case & bushing UL 94V-0
- RoHS compliant

Typical Applications

- Telecommunications
- Instrumentation
- Computers & peripherals

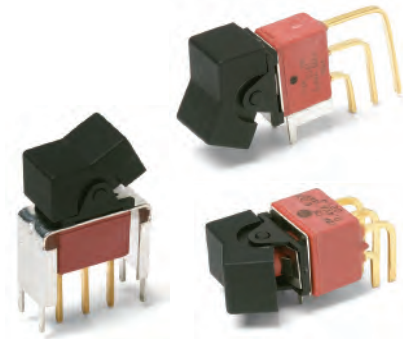

Specifications

CONTACT RATING: B contact material: 0.4 VA max. @ 20 V AC or DC max. Q contact material (E1XX & E2XX Models): 7.5 AMPS @125 V AC or 28 V DC; 3 AMPS @ 250 V AC. (E3XX Models): 5 AMPS @ 125 V AC or 28 V DC; 2 AMPS @ 250 V AC. See page G-36 for additional ratings.

ELECTRICAL LIFE: E1XX and E2XX models: 40,000 make-and-break cycles at full load. E3XX models: 30,000 cycles.

CONTACT RESISTANCE: Below 10 m Ω typ. initial @ 2-4 V DC, 100 mA, for both silver and gold plated contacts.

INSULATION RESISTANCE: 10⁹ Ω min.

ELECTROSTATIC DISCHARGE (ESD) OPTION: All actuator options: 15,000 V DC max. @ sea level, actuator to terminals.

DIELECTRIC STRENGTH: 1000 Vrms min. @ sea level.

OPERATING TEMPERATURE: -30°C to 85°C.

SOLDERABILITY: Per MIL-STD-202F method 208D, or EIA RS-186E method 9 (1 hour steam aging).

Materials

CASE & BUSHING: Glass filled nylon 6/6, flame retardant, heat stabilized (UL 94V-0).

ACTUATOR: Nylon, black standard, internal o-ring seal standard with all actuators.

FRAME: Spring steel, black standard.

SWITCH SUPPORT: Brass or steel, matte-tin plated.

ACTUATOR PIVOT & MOUNTING BRACKET: Nylon.

ACTUATOR PIVOT RETAINER: Stainless steel.

CONTACTS & TERMINALS: B contact material: Copper alloy, with gold plate over nickel plate. Q contact material: Copper alloy, silver plated. See page G-36 for additional contact materials.

TERMINAL SEAL: Epoxy.

HARDWARE: Nut, Screw & Lockwasher: Stainless steel.
Standoff: Nylon standard, aluminum available, consult Customer Service Center.

NOTE: Any models supplied with Q, B, G, S, P & R contact material are RoHS compliant.

NOTE: Specifications and materials listed above are for switches with standard options. For information on specific and custom switches, consult Customer Service Center.

Build-A-Switch

To order, simply select desired option from each category and place in the appropriate box. Available options are shown and described on pages G-26 through G-38. For additional options not shown in catalog, consult Customer Service Center. All models are process sealed to withstand machine soldering temperatures and pressure wash cleaning methods.

| | | | |
|---|---|--|--|
| | | | |
| <p>Switch Function</p> <p>E101 SP On-None-On E103 SP On-Off-On E105 SP Mom.-Off-Mom. E107 SP On-Off-Mom. E108 SP On-None-Mom. E201 DP On-None-On E203 DP On-Off-On E205 DP Mom.-Off-Mom. E207 DP On-Off-Mom. E208 DP On-None-Mom. E211 DP On-On-On E213 DP On-On-Mom. E215 DP Mom.-On-Mom. E301 3P On-None-On</p> | <p>Actuator</p> <p>J1 .531 long rocker J2 Lever J3 .906" long rocker J11 Rocker with frame J21 Lever with frame J50 .362" long rocker J60 Lever J90 Lever</p> | <p>Terminations</p> <p>A Right angle, PC thru-hole AV2 Vertical right angle, PC thru-hole C PC Thru-hole Z Solder lug A3 Right angle, snap-in, PC thru-hole AV3 Vertical right angle, snap-in, PC thru-hole V3 .460" high, V-bracket V4 .630" high, V-bracket V5 Vertical right angle, PC thru-hole V6 .460" high, V-bracket V7 .630" high, V-bracket V8 .953" high, V-bracket V21 .555" high, V-bracket, snap-in V31 .460" high, V-bracket, snap-in</p> | <p>Contact Material</p> <p>B Gold P Gold, matte tin Q Silver S Silver, matte-tin G Gold over silver R Gold over silver, matte-tin</p> <p>Seal</p> <p>E Epoxy</p> <p>Actuator Color</p> <p>2 Black 3 Red</p> <p>Frame Color</p> <p>2 Black NONE No frame color required</p> <p>Metal Frame Color (J11, J21 Actuators) 2 Black</p> |

Rocker



Dimensions are shown: Inches (mm)
Specifications and dimensions subject to change



E Series Sealed Miniature Rocker and Lever Handle Switches

SWITCH FUNCTION

| NO. POLES | MODEL NO. | SWITCH FUNCTION | | | CONNECTED TERMINALS | | | SCHEMATIC |
|-------------------------------|---------------|------------------------------|--------|--------|------------------------------|--------|---------|-----------|
| | | POS. 1 | POS. 2 | POS. 3 | POS. 1 | POS. 2 | POS. 3 | |
| | | | | | | | | |
| | | C&K marking on opposite side | | | C&K marking on opposite side | | | |
| SP | E101 | ON | NONE | ON | 2-3 | N/A | 2-1 | |
| | E103 | ON | OFF | ON | | OPEN | | |
| | E105 | MOM. | OFF | MOM. | | | | |
| | E107 | ON | OFF | MOM. | | | | |
| | E108 | ON | NONE | MOM. | | | | |
| SPDT | | | | | | | | |
| Part number shown: E101J1ZBE2 | | | | | | | | |
| DP | E201 | ON | NONE | ON | 2-3,5-6 | N/A | 2-1,5-4 | |
| | E203 | ON | OFF | ON | | OPEN | | |
| | E205 | MOM. | OFF | MOM. | | | | |
| | E207 | ON | OFF | MOM. | | | | |
| | E208 | ON | NONE | MOM. | | | | |
| | E211** | ON | ON | ON | | | | |
| | E213** | ON | ON | MOM. | | | | |
| | E215** | MOM. | ON | MOM. | | | | |
| DPDT | | | | | | | | |
| Part number shown: E201J1ZBE2 | | | | | | | | |

MOM. = Momentary

** Wiring for 3-way switch, Hardware available separately, see Technical Data section of this catalog.

All models with all options when ordered with G, Q, R or S contact material.

Rocker



G



Third Angle Projection

Dimensions are shown: Inches (mm)
Specifications and dimensions subject to change

E Series Sealed Miniature Rocker and Lever Handle Switches

SWITCH FUNCTION

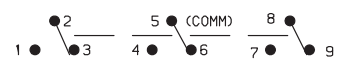
| NO. POLES | MODEL NO. | SWITCH FUNCTION | | | CONNECTED TERMINALS | | | SCHEMATIC |
|-----------|-------------|-----------------|--------|--------|---------------------|--------|-------------|---|
| | | POS. 1 | POS. 2 | POS. 3 | POS. 1 | POS. 2 | POS. 3 | |
| 3P | E301 | ON | NONE | ON | 2-3-5-6,8-9 | N/A | 2-1,5-4,8-7 |  3PDT |

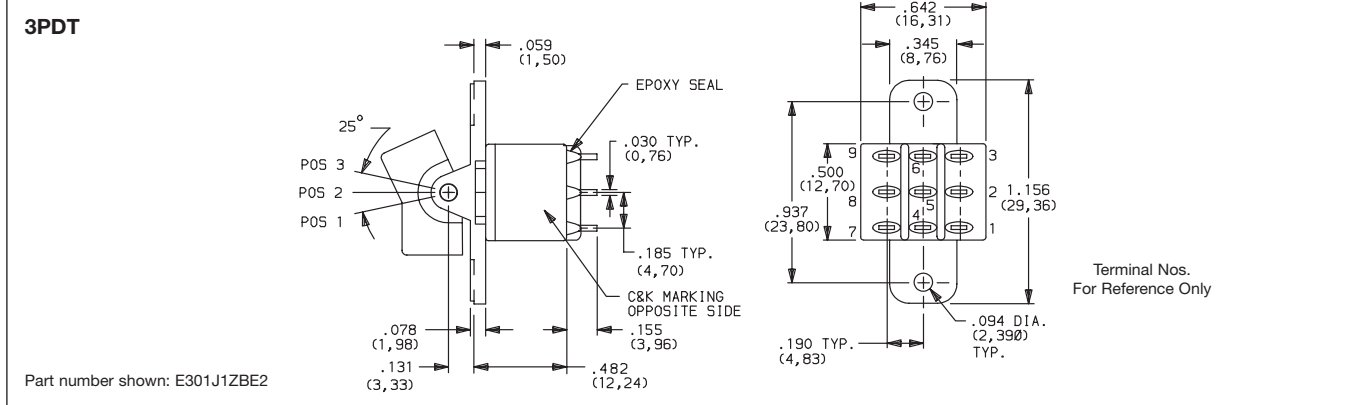

MOM. = Momentary

** Wiring for 3-way switch, see Technical Data section of this catalog.

All models  with all options when ordered with G, Q, R and S contact material.

ACTUATOR-PANEL REAR MOUNT

| OPTION CODE | ACTUATOR COLOR |
|-------------|----------------|
| 2 | BLACK |
| 3 | RED |

Finish: Matte. Other colors, custom actuator markings and legends available, consult Customer Service Center.

NOTE: Hardware: two each—mounting screws, nuts, lockwashers and standoffs for 1/8 inch thick panel are supplied standard on switches with panel mounting bracket. Internal o-ring actuator seal standard. Actuators available separately, see page G-36. Hardware available separately, see Technical Data section of this catalog. J1, J2 actuators available with C, Z or Z3 terminations.

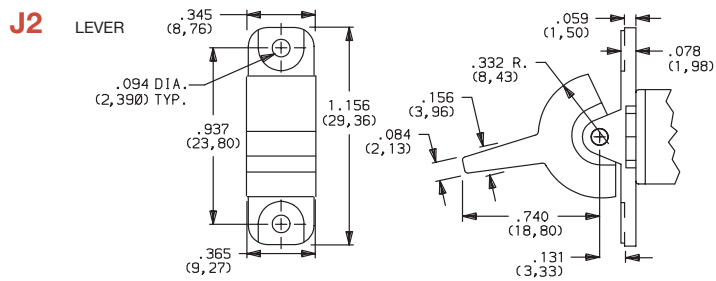
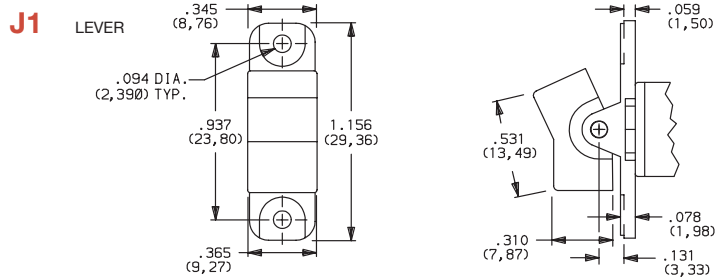
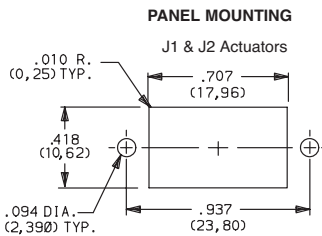

Rocker

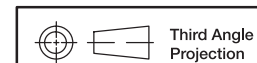

Dimensions are shown: Inches (mm)
Specifications and dimensions subject to change



E Series Sealed Miniature Rocker and Lever Handle Switches

ACTUATOR-REAR MOUNT

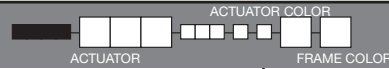

J11 ROCKER WITH FRAME

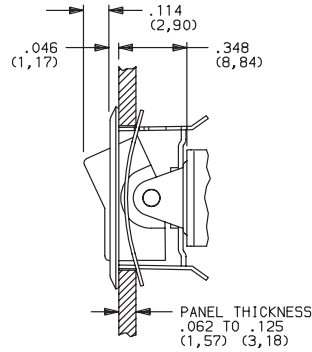
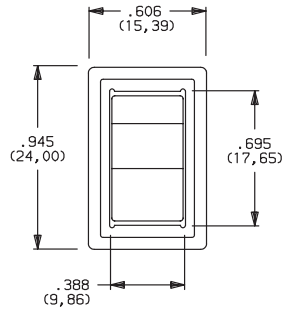

NOTE: This option has reduced anti-static capability.

| OPTION CODE | ACTUATOR COLOR |
|-------------|----------------|
| 2 | BLACK |
| 3 | RED |

| OPTION CODE | FRAME COLOR |
|-------------|-------------|
| 2 | BLACK |

J21 LEVER WITH FRAME

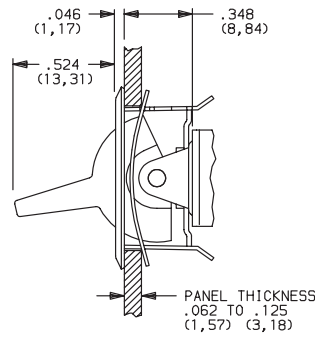
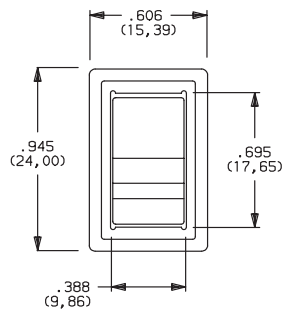

NOTE: This option has reduced anti-static capability.

Actuator finish: Matte, frame finish: gloss. Other colors, custom actuator markings and legends available, consult Customer Service Center.

NOTE: Internal o-ring actuator seal standard. Actuators & frames available separately, see page G-36. Hardware available separately, see Technical Data section of this catalog. N, J11 & J21 actuators available with C, Z & Z3 terminations.

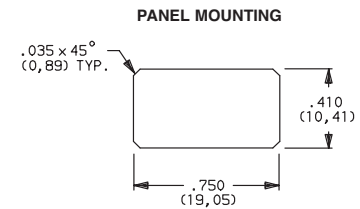

ACTUATOR-PC MOUNT

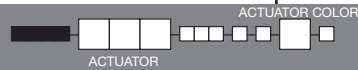

J1 ROCKER

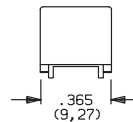
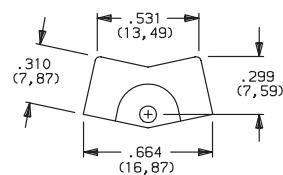

| OPTION CODE | ACTUATOR COLOR |
|-------------|----------------|
| 2 | BLACK |
| 3 | RED |

J2 LEVER

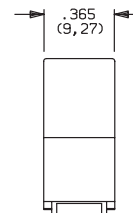
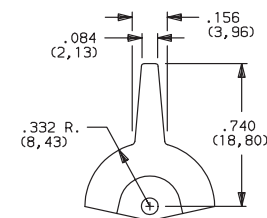

Finish: Matte. Other colors, custom actuator markings and legends available, consult Customer Service Center.

NOTE: Hardware: two each—mounting screws, nuts, lockwashers and standoffs for 1/8 inch thick panel are supplied standard on switches with panel mounting bracket. Internal o-ring actuator seal standard. Actuators available separately, see page G-36. Hardware available separately, see Technical Data section of this catalog. J1, J2 actuators available with A, A3, AV2, AV3, V2-V61 terminations.

Rocker



G

C&K



Dimensions are shown: Inches (mm)
Specifications and dimensions subject to change

E Series Sealed Miniature Rocker and Lever Handle Switches

ACTUATOR-PC MOUNT

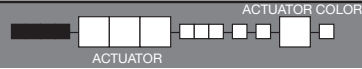

| OPTION CODE | ACTUATOR COLOR |
|-------------|----------------|
| 2 | BLACK |
| 3 | RED |

Finish: Matte. Other colors, custom actuator markings and legends available, consult Customer Service Center.

NOTE: Hardware: two each—mounting screws, nuts, lockwashers and standoffs for 1/8 inch thick panel are supplied standard on switches with panel mounting bracket. Internal o-ring actuator seal standard. Actuators available separately, see page G-36. Hardware available separately, see Technical Data section of this catalog.

J3 actuators available with AV2, AV3 & V2-V61 terminations. Some permissible actuator/termination combinations may lack clearance between actuator and PC board, and care must be exercised to accommodate this condition.

J50, J60 & J90 actuators available with A, AV2, AV3, V2 - V61 terminations.

J3 ROCKER

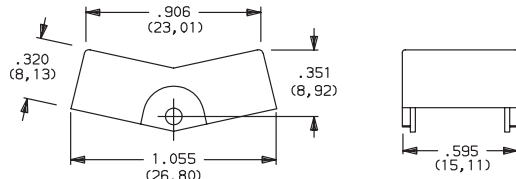

J50 ROCKER

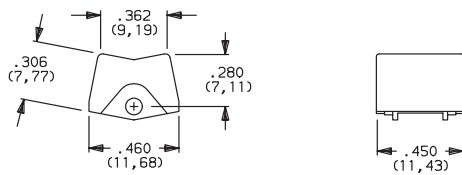

J60 LEVER

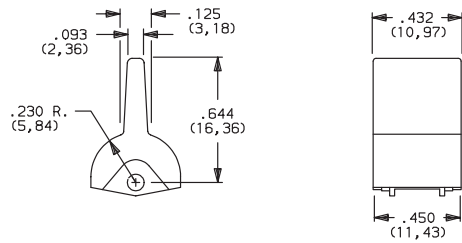

J90 LEVER

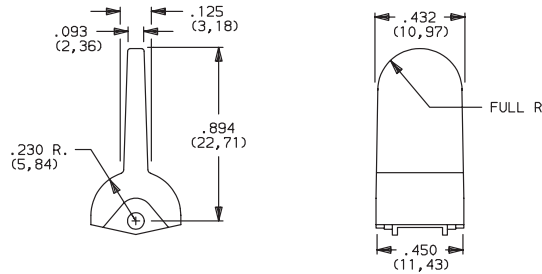

TERMINATIONS



Z SOLDER LUG

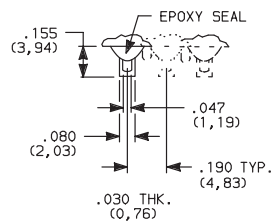

SPDT thru 3PDT

Not available with P, S, & R contact materials. Available actuators, see page G-27-28.

C PC THRU-HOLE

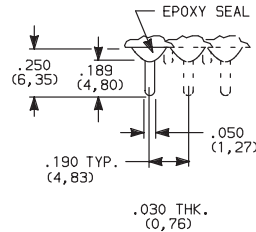

SPDT thru 3PDT

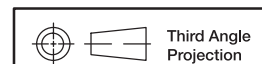
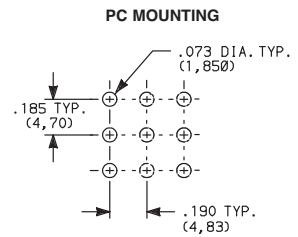

Dimensions are shown: Inches (mm)
Specifications and dimensions subject to change



E Series Sealed Miniature Rocker and Lever Handle Switches

TERMINATIONS

Z3 QUICK CONNECT

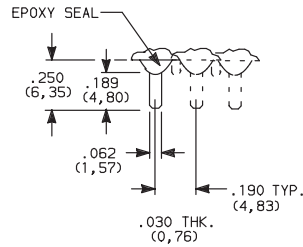

Not available with P, S, & R contact materials. Available actuators, see pages G-27 thru G-28. Mating quick connector available; order part number 530100000, page G-37.

SPDT thru 3PDT

A RIGHT ANGLE, PC THRU-HOLE



E101J1ABE2
Horizontal Actuation
SPDT

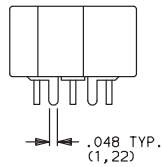

Actuator Shown In Pos. 1

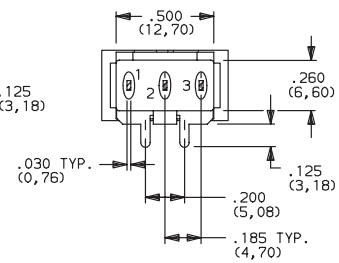
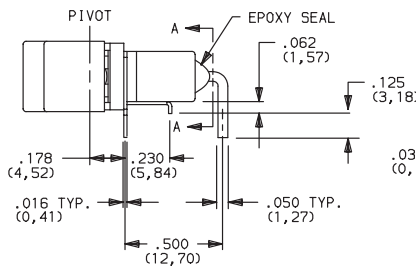

SECTION A-A

A3 RIGHT ANGLE, SNAP-IN, PC THRU-HOLE

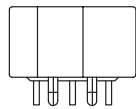

.050 TYP.
(1,27)

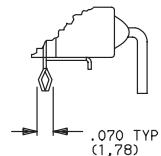

.070 TYP.
(1,78)

PC MOUNTING

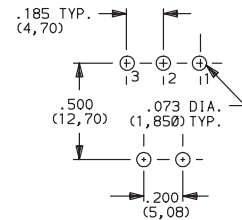

NOTE: PC mounting pattern must clear switch support leg.

NOTE: Not available with J3, J50, J60 and J90 actuators. Available actuators, see pages G-27 thru G-29. Terminal bend radii and lead-in manufacturing option.

A RIGHT ANGLE, PC THRU-HOLE



E201J1ABE2
Horizontal Actuation
DPDT

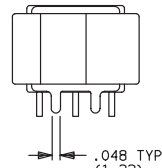

Actuator Shown In Pos. 1

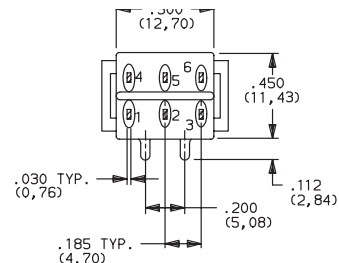
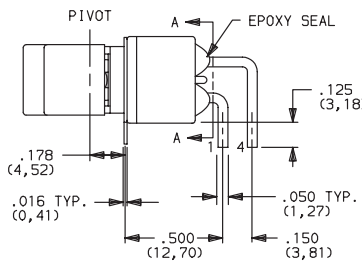

SECTION A-A

A3 RIGHT ANGLE, SNAP-IN, PC THRU-HOLE

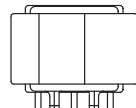

.048 TYP.
(1,22)

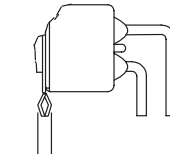

.070 TYP.
(1,78)

PC MOUNTING

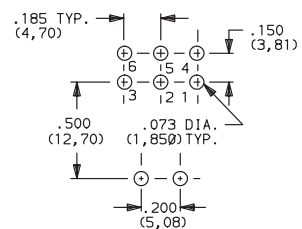

Third Angle Projection

Dimensions are shown: Inches (mm)
Specifications and dimensions subject to change

Rocker

NOTE: Not available with J3 actuator. Available actuators, see pages G-27 thru G-29. Terminal bend radii and lead-in manufacturing option.



G

C&K

E Series Sealed Miniature Rocker and Lever Handle Switches

TERMINATIONS

A RIGHT ANGLE, PC THRU-HOLE

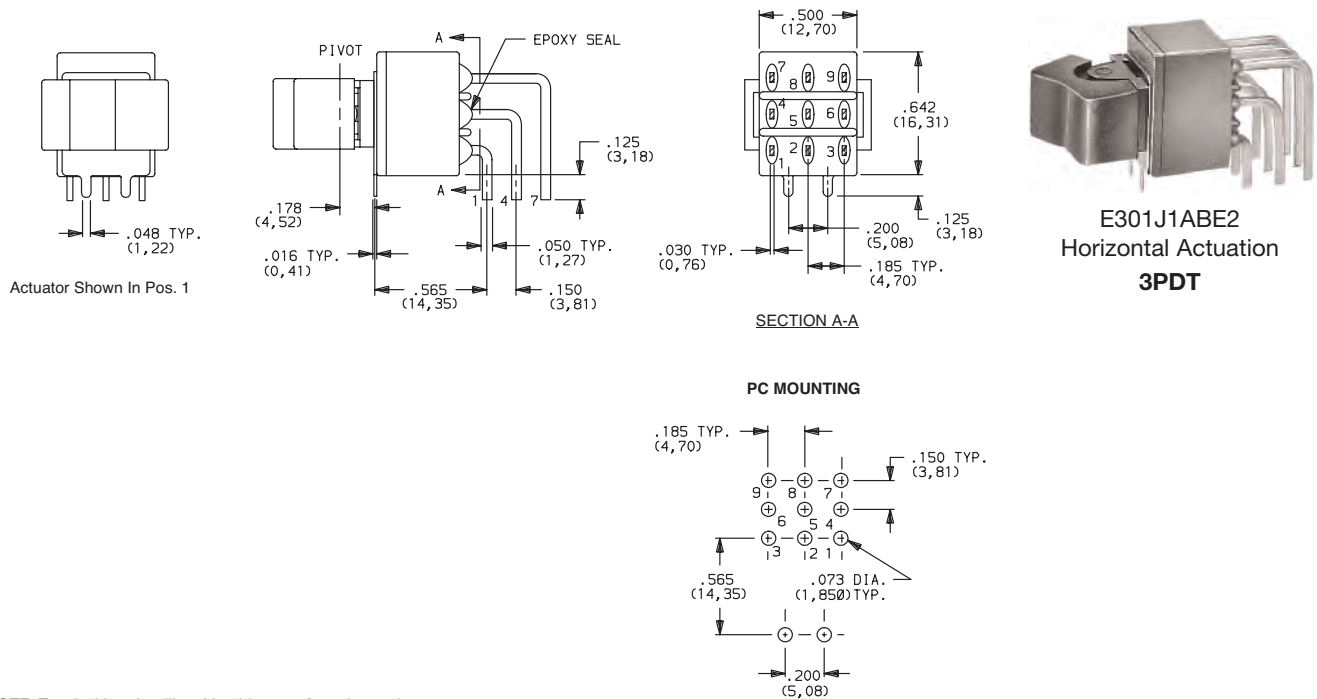

AV2 VERTICAL RIGHT ANGLE, PC THRU-HOLE, .150" PITCH

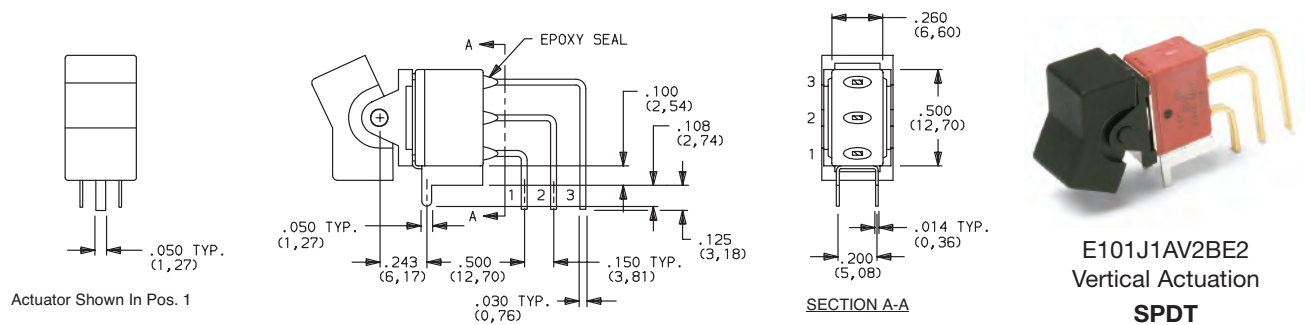

AV3 VERTICAL RIGHT ANGLE, SNAP-IN, PC THRU-HOLE, .150" PITCH

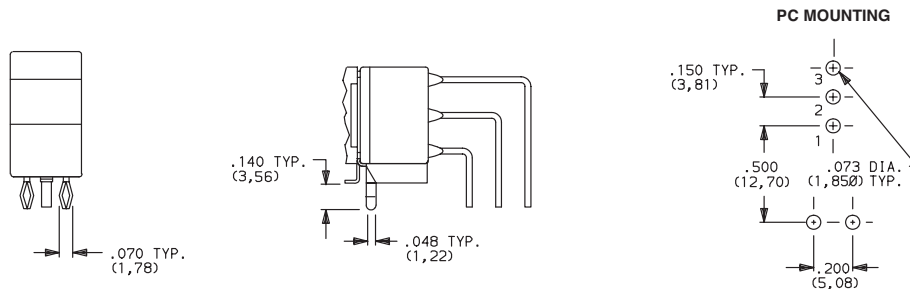

E Series Sealed Miniature Rocker and Lever Handle Switches

TERMINATIONS

AV2 VERTICAL RIGHT ANGLE, PC THRU-HOLE,
.150" PITCH



E201J1AV2BE2
Vertical Actuation
DPDT

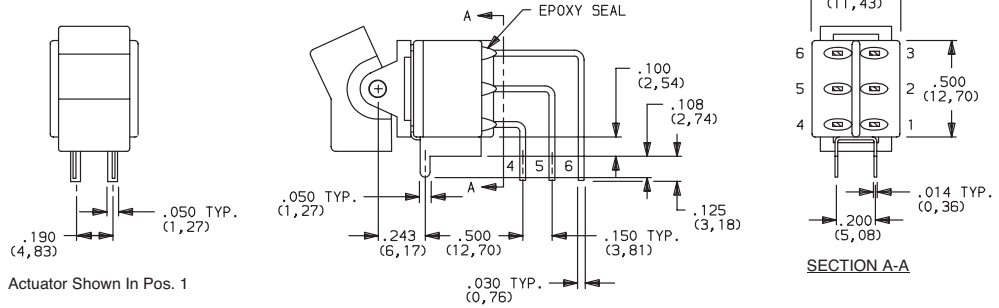

AV3 VERTICAL RIGHT ANGLE, SNAP-IN, PC THRU-HOLE,
.150" PITCH

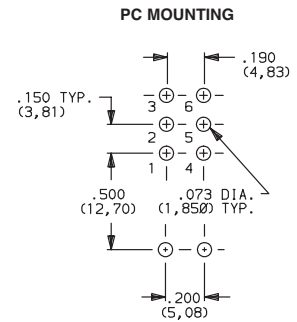
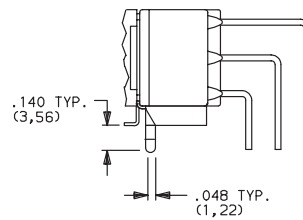
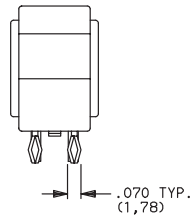

NOTE: Terminal bend radii and lead-in manufacturing option.
Available actuators, see pages G-27 thru G-29.

AV2 VERTICAL RIGHT ANGLE, PC THRU-HOLE,
.150" PITCH



E301J1AV2BE2
Vertical Actuation
3PDT

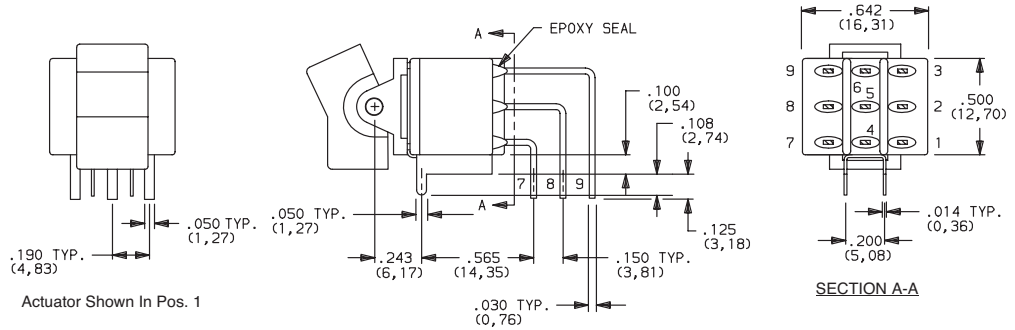

AV3 VERTICAL RIGHT ANGLE, SNAP-IN, PC THRU-HOLE,
.150" PITCH

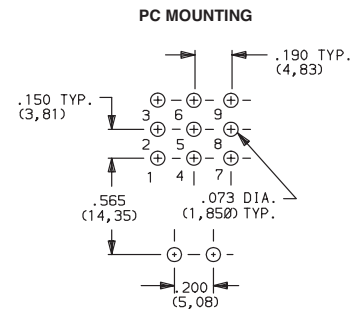
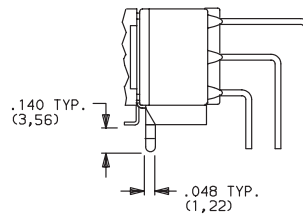
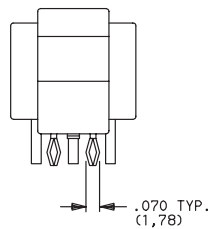

Rocker

NOTE: Terminal bend radii and lead-in manufacturing option.
Available actuators, see pages G-27 thru G-29.



Dimensions are shown: Inches (mm)
Specifications and dimensions subject to change



E Series Sealed Miniature Rocker and Lever Handle Switches

TERMINATIONS

V5 VERTICAL RIGHT ANGLE, PC THRU-HOLE,
.150" PITCH

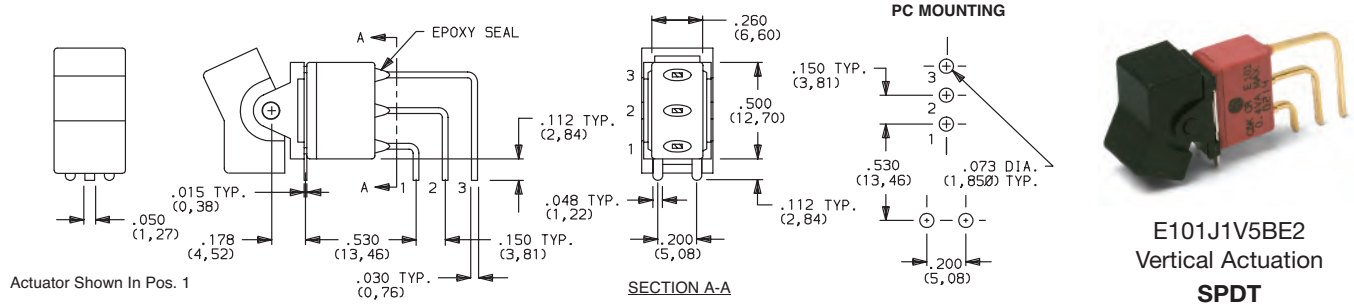

NOTE: Terminal bend radii and lead-in manufacturing option.
Available actuators, see pages G-27 thru G-29.

V5 VERTICAL RIGHT ANGLE, PC THRU-HOLE,
.150" PITCH

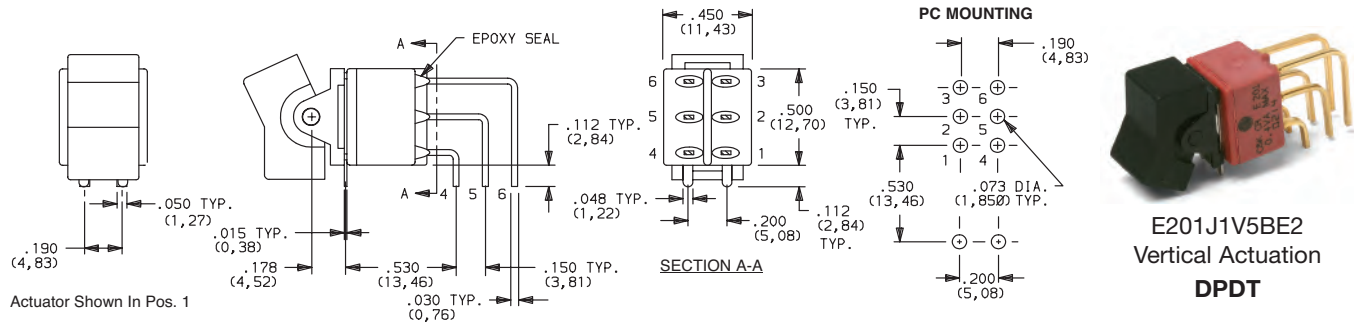

NOTE: Terminal bend radii and lead-in manufacturing option.
Available actuators, see pages G-27 thru G-29.



E Series Sealed Miniature Rocker and Lever Handle Switches

TERMINATIONS

V6, V7, V8 VERTICAL MOUNT, V-BRACKET

V21 VERTICAL MOUNT, V-BRACKET, SNAP-IN



E101J1__BE2
SPDT

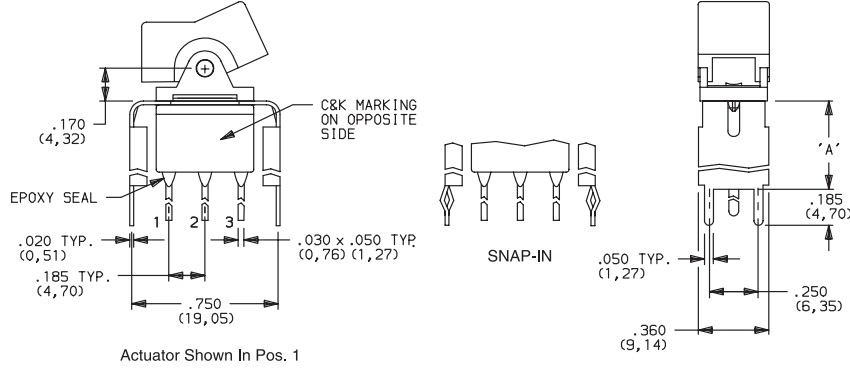

PC MOUNTING

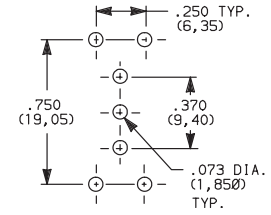

| OPTION CODE | DIM 'A' |
|-------------|---------------|
| V21 | .555 (14, 10) |
| V6 | .460 (11, 68) |
| V7 | .630 (16, 00) |
| V8 | .953 (24, 21) |

NOTE: Available actuators, see pages G-27 thru G-29.

V6, V7, V8 VERTICAL MOUNT, V-BRACKET

V21 VERTICAL MOUNT, V-BRACKET, SNAP-IN



E201J1__BE2
DPDT

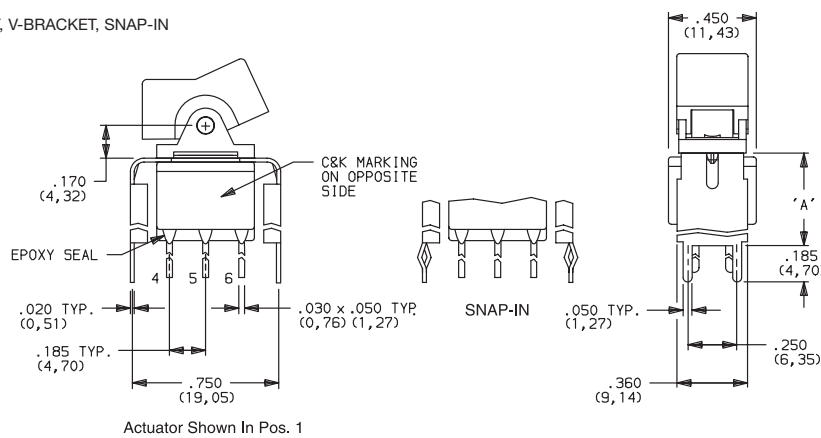

PC MOUNTING

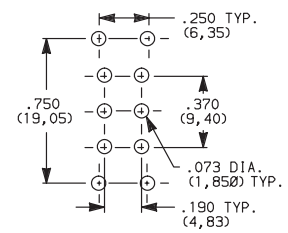

| OPTION CODE | DIM 'A' |
|-------------|---------------|
| V21 | .555 (14, 10) |
| V6 | .460 (11, 68) |
| V7 | .630 (16, 00) |
| V8 | .953 (24, 21) |

NOTE: Available actuators, see pages G-27 thru G-29.

V7, V8 VERTICAL MOUNT, V-BRACKET

V21 VERTICAL MOUNT, V-BRACKET, SNAP-IN

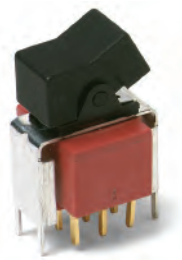

E301J1__BE2
3PDT

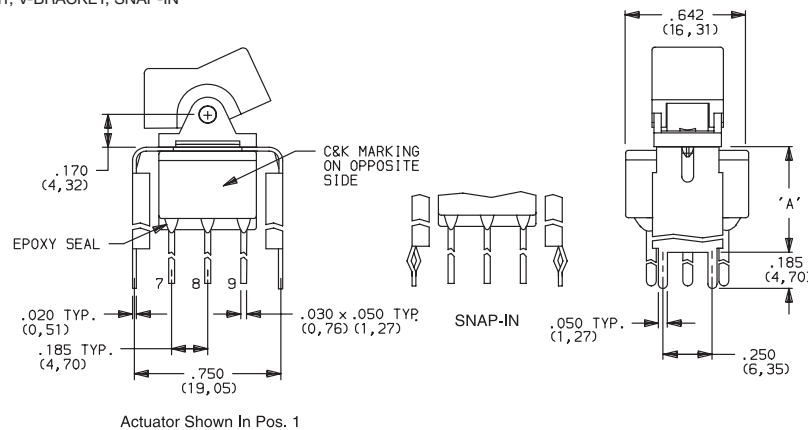

PC MOUNTING

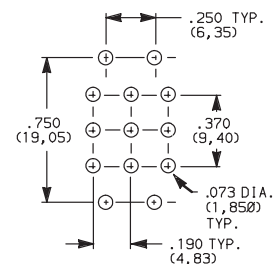

| OPTION CODE | DIM 'A' |
|-------------|---------------|
| V21 | .555 (14, 10) |
| V7 | .630 (16, 00) |
| V8 | .953 (24, 21) |

NOTE: Available actuators, see pages G-27 thru G-29.

Rocker



G



Third Angle Projection
Dimensions are shown: Inches (mm)
Specifications and dimensions subject to change

E Series Sealed Miniature Rocker and Lever Handle Switches

TERMINATIONS

V3, V4 VERTICAL MOUNT, V-BRACKET

V31 VERTICAL MOUNT, V-BRACKET, SNAP-IN

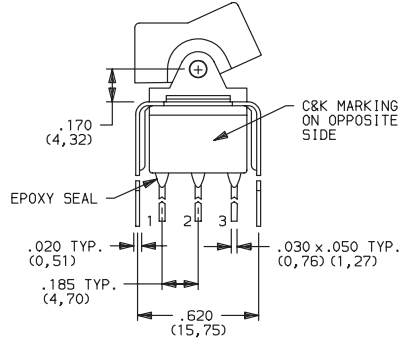

Actuator Shown In Pos. 1

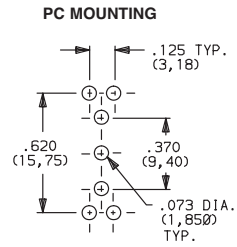
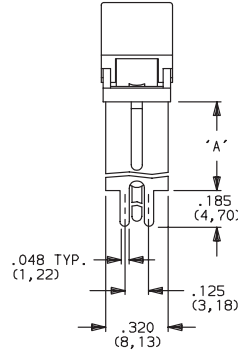
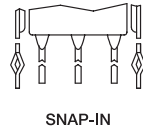

E101J1_BE2
SPDT

| OPTION CODE | DIM 'A' |
|----------------|--------------|
| V3, V31 | .460 (11,68) |
| V4 | .630 (16,00) |

NOTE: Available actuators, see pages G-27 thru G-29.

V3, V4 VERTICAL MOUNT, V-BRACKET

V31 VERTICAL MOUNT, V-BRACKET, SNAP-IN

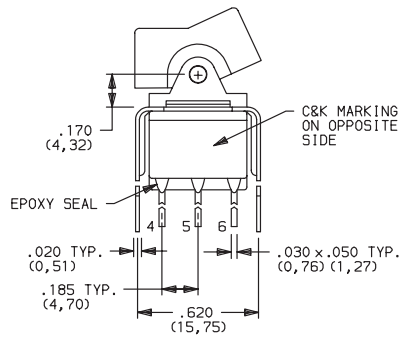

Actuator Shown In Pos. 1

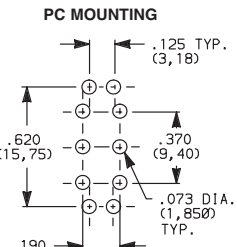
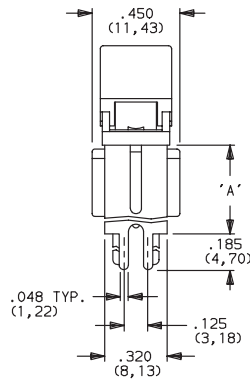
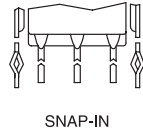

E201J1_BE2
DPDT

| OPTION CODE | DIM 'A' |
|----------------|--------------|
| V3, V31 | .460 (11,68) |
| V4 | .630 (16,00) |

NOTE: Available actuators, see pages G-27 thru G-29.

V4 VERTICAL MOUNT, V-BRACKET

VERTICAL MOUNT, V-BRACKET, SNAP-IN

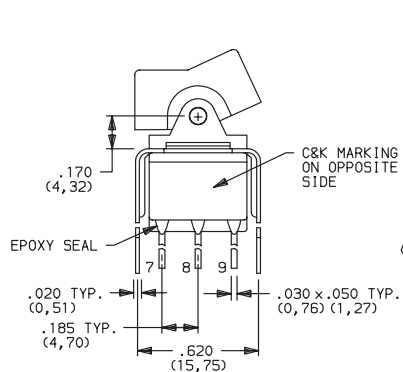

Actuator Shown In Pos. 1

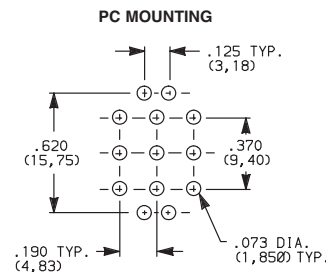
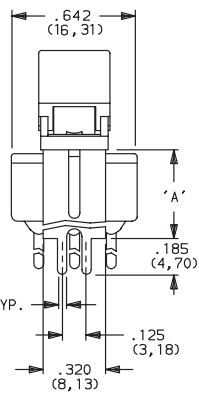
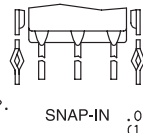

E301J1_BE2
3PDT

| OPTION CODE | DIM 'A' |
|-------------|--------------|
| V41 | .630 (16,00) |

NOTE: Available actuators, see pages G-27 thru G-29.



E Series Sealed Miniature Rocker and Lever Handle Switches

CONTACT MATERIAL

| OPTION CODE | CONTACT MATERIAL | TERMINAL PLATING | RATINGS | |
|-------------|------------------------------------|------------------------|-----------------------------------|---|
| B | GOLD ¹ | GOLD ¹ | LOW LEVEL/ DRY CIRCUIT | 0.4 VA MAX. @ 20 V AC OR DC MAX. |
| P | | MATTE-TIN ⁷ | | |
| Q | SILVER ^{4,5} | SILVER ⁵ | POWER | E1XX & E2XX MODELS: 7.5 AMPS @125 V AC OR 28 V DC; 3 AMPS @250 V AC. E3XX MODELS: 5 AMPS @ 125 V AC OR 28 V DC; 2 AMPS @ 250 V AC. |
| S | | MATTE-TIN ⁶ | | |
| G | GOLD OVER SILVER ^{2,3} | GOLD ³ | LOW LEVEL/DRY CIRCUIT OR POWER | E1XX AND E2XX MODELS: 0.4 VA MAX @20 V AC OR DC MAX. OR 7.5 AMPS @125 V AC OR 28 V DC; 3 AMPS @ 250 V AC. DC E3XX MODELS: 0.4 VA MAX. @ 20 V AC OR DC MAX. OR 5 AMPS @ 125 V AC OR 28 V DC; 2 AMPS @ 250 V AC. |
| R | | MATTE-TIN ⁶ | | |

* Note: See Technical Data section of this catalog for RoHS compliant and compatible definitions and specifications.

¹ CONTACTS & TERMINALS: Copper alloy, with gold plate over nickel plate.

² END CONTACTS: Coin silver, with gold plate over nickel plate.

³ CENTER CONTACTS & ALL TERMINALS: Copper alloy, with gold plate over nickel plate.

⁴ END CONTACTS: Coin silver, silver plated.

⁵ CENTER CONTACT & ALL TERMINALS: Copper alloy, with gold flash over silver plate. Or copper alloy, silver plated.

⁶ TERMINALS: Copper alloy, with matte-tin over nickel plate.

NOTE: Any models supplied with Q, B, G, S P & R contact material are RoHS compliant.

All models with all options when ordered with G, Q, S & R contact material.

B contact material standard with all terminations.

P R & S contact materials not available with Z terminations.

SEAL

E EPOXY SEAL



AVAILABLE HARDWARE

J2, J21 Actuators



PART NO.
760502263 BLACK
760503000 RED

Material: Nylon
Finish: Matte

J3 Actuator



PART NO.
766602263 BLACK
766603000 RED

Material: Nylon
Finish: Matte

J1, J11 Actuators



PART NO.
776A02263 BLACK
776A03000 RED

Material: Nylon
Finish: Matte

J50 Actuator



PART NO.
775A02263 BLACK
775A03000 RED

Material: Nylon
Finish: Matte

J60 Actuator



PART NO.
613802263 BLACK
598103000 RED

Material: Nylon
Finish: Matte

J90 Actuator



PART NO.
598002263 BLACK
598003000 RED

Material: Nylon
Finish: Matte

NOTE: Additional nuts, screws and lockwashers available separately, see Technical Data section of this catalog. Other colors available, consult Customer Service Center.

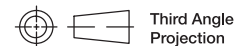

Third Angle
Projection

Dimensions are shown: Inches (mm)
Specifications and dimensions subject to change

Rocker



G

C&K

E Series Sealed Miniature Rocker and Lever Handle Switches

AVAILABLE HARDWARE

Fits Z3 Termination female connector



PART NO.
530100000

Available in loose pieces.

Frame for J11, J21 Actuators



PART NO.
764500746 BLACK ENAMEL
764601106 RETAINING SPRING
Material: Spring Steel



J50, J60 & J90 Actuators

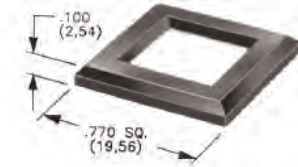

| | |
|------------------------|------------------------|
| MATTE | GLOSS |
| PART NO. | PART NO. |
| 486702000 | 486802000 BLACK |
| Material: Nylon | |
| Finish: Matte or Gloss | |

NOTE: Additional nuts, screws and lockwashers available separately, see Technical Data section of this catalog. Other colors available, consult Customer Service Center.

Frames snap into panel opening and are independent from switch mounting. Accurate positioning of the PC mounted switch relative to the panel opening is necessary to provide proper clearance between actuator and frame. Available in two basic styles and four panel thicknesses .047-.125 in. Material: Nylon. Finish: Matte.

TYPICAL APPLICATION

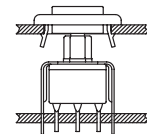

J1 & J2 Actuators

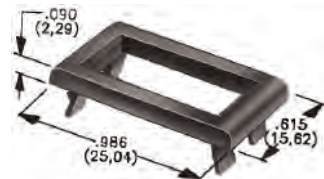

| | | | |
|-------------------------|-------------------------|-------------------------|-------------------------|
| .047" (1,19) PANEL THK. | .062" (1,57) PANEL THK. | .090" (2,29) PANEL THK. | .125" (3,18) PANEL THK. |
| PART NO. | PART NO. | PART NO. | PART NO. |
| 452902263 | 452702263 | 452802263 | 452602263 BLACK |
| 452903000 | 452703000 | 452803000 | 452603000 RED |

J50, J60 & J90 Actuators

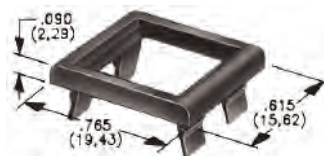

| | | | |
|-------------------------|-------------------------|-------------------------|-------------------------|
| .047" (1,19) PANEL THK. | .062" (1,57) PANEL THK. | .090" (2,29) PANEL THK. | .125" (3,18) PANEL THK. |
| PART NO. | PART NO. | PART NO. | PART NO. |
| 432502263 | 432602263 | 432702263 | 432802263 BLACK |
| 432503000 | 432603000 | 432703000 | 432803000 RED |

PANEL MOUNTING

For part numbers
4529xxxxx, 4527xxxxx,
4528xxxxx, 4526xxxxx

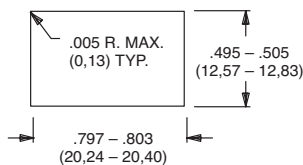

For part numbers
4325xxxxx, 4326xxxxx

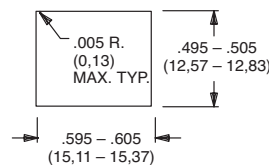

For part numbers
4327xxxxx, 4328xxxxx

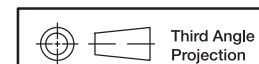
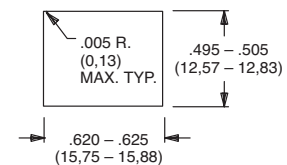

Dimensions are shown: Inches (mm)
Specifications and dimensions subject to change



E Series Sealed Miniature Rocker and Lever Handle Switches

AVAILABLE HARDWARE

Panel Inserts

Will fit separate snap-in frames for J50, J60, J90 actuators.

Above frames (part nos. 432XXXXXX) are also available with insert which accepts LED for indicator light assembly. Order insert separately from frame. Blank insert panel (without hole for LED) also available. **LED not included.**

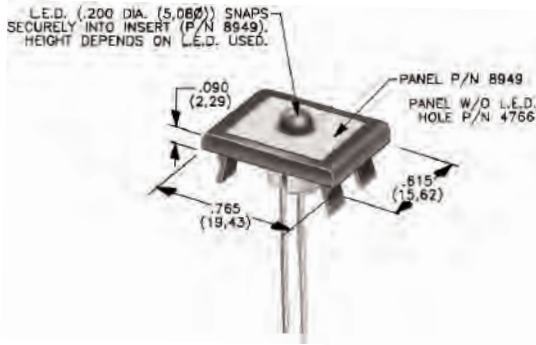

PANEL INSERT WITH HOLE FOR LED

BLANK PANEL INSERT WITHOUT HOLE FOR LED

PART NO.
894902000
894903000

PART NO.
476602000 BLACK
476603000 RED

NOTE: Special colors, custom markings available, consult Customer Service Center.

Rocker



Dimensions are shown: Inches (mm)
Specifications and dimensions subject to change

ET Series Sealed Subminiature Rocker Switches

Features/Benefits

- Sealed against solder and cleaning process contaminants
- Rocker, bushing & case—UL 94V-0
- Small footprint—saves space
- RoHS compliant

Typical Applications

- Telecommunications
- Instrumentation
- Computers & peripherals

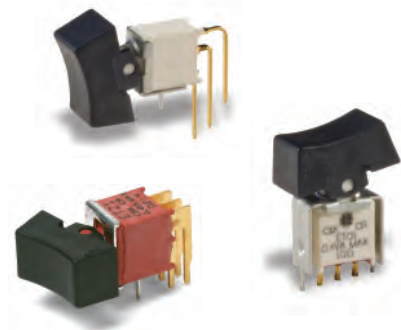

Specifications

CONTACT RATING: B contact material: 0.4 VA max. @ 20 V AC or DC max. Q contact material: Copper alloy, silver plated. See page G-43 for additional ratings.

ELECTRICAL LIFE: ETX1 models: 60,000 make-and-break cycles at full load. All other models: 30,000 cycles.

CONTACT RESISTANCE: Below 20 m Ω typ. initial @ 2-4 V DC, 100 mA, for both silver and gold plated contacts.

INSULATION RESISTANCE: 10⁹ Ω min.

DIELECTRIC STRENGTH: 1000 Vrms min. @ sea level.

OPERATING TEMPERATURE: -30°C to 85°C.

SOLDERABILITY: Per MIL-STD-202F method 208D, or EIA RS-186E method 9 (1 hour steam aging).

PACKAGING: Surface mount switches standard in tape and reel packaging, see page G-45 for drawings and reel information.

Materials

CASE & BUSHING: Glass filled nylon 6/6, flame retardant, heat stabilized (UL 94V-0) or glass filled 4/6 nylon, flame retardant, heat stabilized (UL 94V-0).

ACTUATOR: Nylon, black standard. Internal o-ring seal standard with all actuators. SA surface mount: High temperature material, glass filled 46 nylon, flame retardant, heat stabilized (UL 94V-0).

SWITCH SUPPORT: Brass, matte-tin plated.

CONTACTS & TERMINALS: B contact material: Copper alloy, with gold plate over nickel plate. Q contact material: Copper alloy, silver plated. See page G-43 for additional contact materials.

TERMINAL SEAL: Epoxy.

NOTE: Any models supplied with Q, B, G, S, P & R contact material are RoHS compliant.

NOTE: Specifications and materials listed above are for switches with standard options. For information on specific and custom switches, consult Customer Service Center.

Build-A-Switch

To order, simply select desired option from each category and place in the appropriate box. Available options are shown and described on pages G-40 thru G-44. For additional options not shown in catalog, consult Customer Service Center. All models are process sealed to withstand machine soldering temperatures and pressure wash cleaning methods.

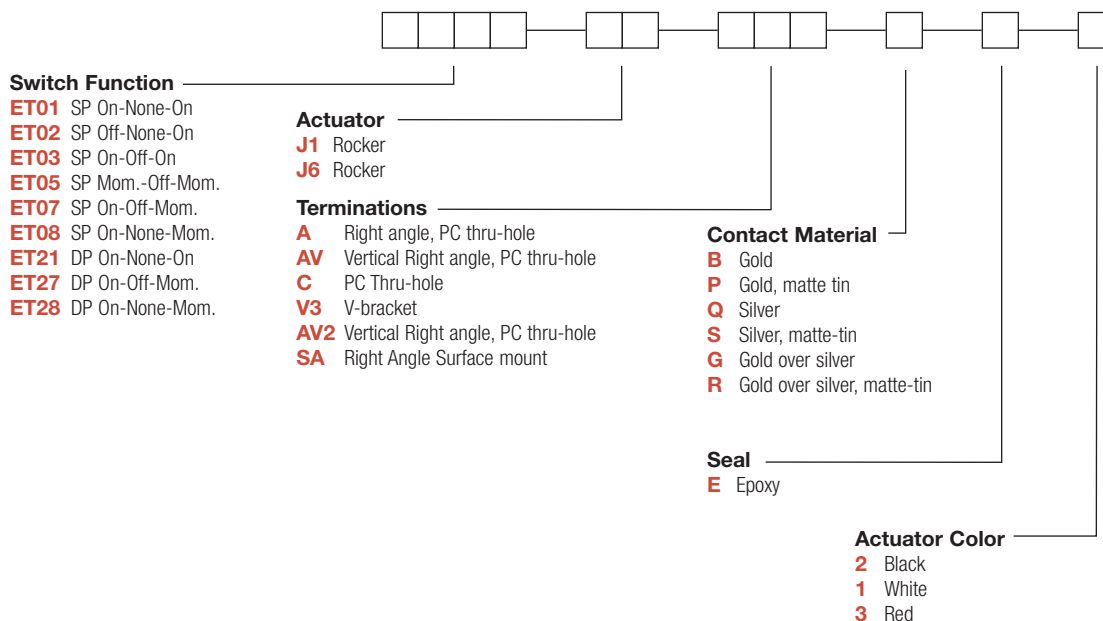

ET Series Sealed Subminiature Rocker Switches

SWITCH FUNCTION

| NO. POLES | MODEL NO. | SWITCH FUNCTION | | | CONNECTED TERMINALS | | | SCHEMATIC |
|---|-------------|-----------------|--------|--------|---------------------|--------|---------|-----------|
| | | POS. 1 | POS. 2 | POS. 3 | POS. 1 | POS. 2 | POS. 3 | |
| SP | ET01 | ON | NONE | ON | 2-3 | N/A | 2-1 | |
| | ET03 | ON | OFF | ON | | OPEN | | |
| | ET05 | MOM. | OFF | MOM. | | | | |
| | ET07 | ON | OFF | MOM. | N/A | | | |
| | ET08 | ON | NONE | MOM. | | | | |
| | ET02 | OFF | NONE | ON | OPEN | N/A | 3-1 | |
| <p>SPDT</p> <p>Part number shown: ET01J6CBE2</p> <p>ET02 Models: Omit terminal 2</p> <p>Terminal Nos. For Reference Only</p> | | | | | | | | |
| DP | ET21 | ON | NONE | ON | 2-3,5-6 | N/A | 2-1,5-4 | |
| | ET27 | ON | OFF | MOM. | | OPEN | | |
| | ET28 | ON | NONE | MOM. | | | | |
| <p>DPDT</p> <p>Part number shown: ET21J6CBE2</p> <p>Terminal Nos. For Reference Only</p> | | | | | | | | |

MOM. = Momentary

All models with all options when ordered with G, S, R or Q contact material.

Rocker

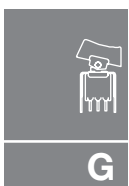

Dimensions are shown: Inches (mm)
Specifications and dimensions subject to change

www.ck-components.com

ET Series Sealed Subminiature Rocker Switches

ACTUATOR

J1 ROCKER

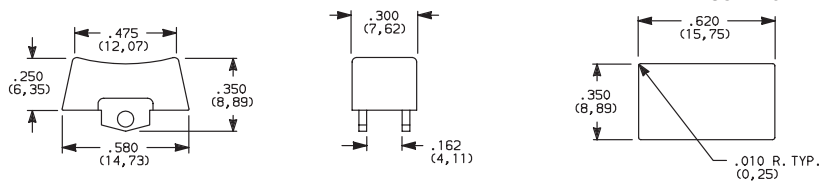

Available with all models except ETOX with A & SA & SA1 terminations.

J6 ROCKER

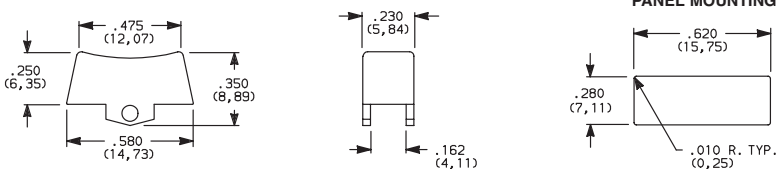

Standard with ETOX model with A & SA & SA1 terminations.

| OPTION CODE | ACTUATOR COLOR |
|-------------|----------------|
| 2 | BLACK |
| 1 | WHITE |
| 3 | RED |

Actuators available separately, see page G-45. Finish: Matte. Other colors, custom actuator markings and legends available, consult Customer Service Center.

NOTE: Internal o-ring actuator seal standard.

TERMINATIONS

C PC THRU-HOLE

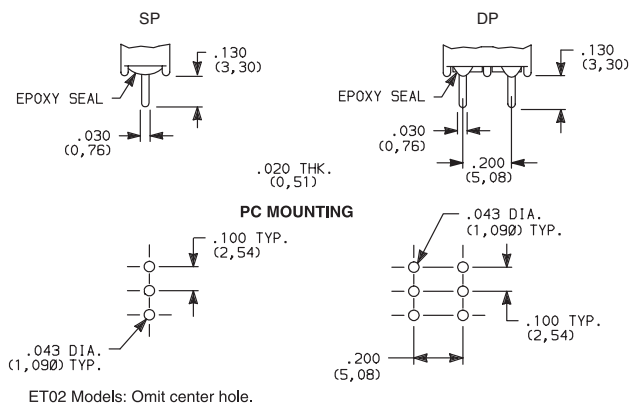

SP & DP

A RIGHT ANGLE, PC THRU-HOLE

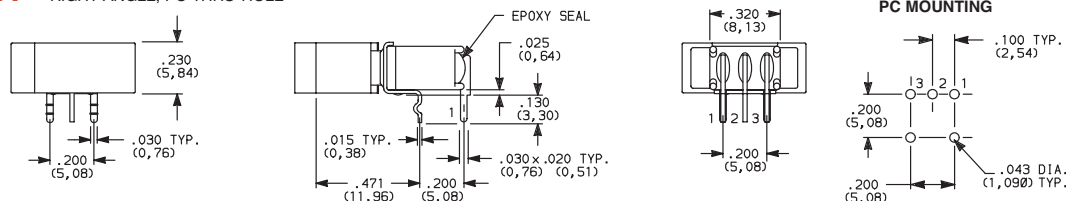

Actuator Shown In Pos. 1

Not available with ET02 model.
J6 actuator std. only on ETOX models with A terminations.



ET01J6ABE2
Horizontal Actuation
SPDT

A RIGHT ANGLE, PC THRU-HOLE

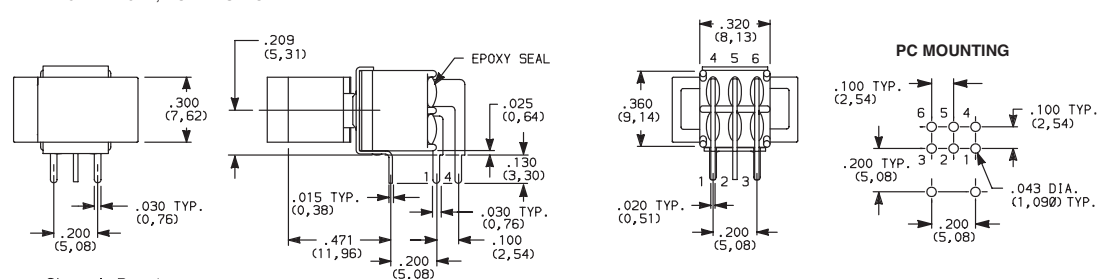

Actuator Shown In Pos. 1



ET21J1ABE2
Horizontal Actuation
DPDT

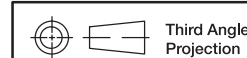

Third Angle
Projection
Dimensions are shown: Inches (mm)
Specifications and dimensions subject to change



ET Series Sealed Subminiature Rocker Switches

TERMINATIONS

AV VERTICAL RIGHT ANGLE, PC THRU-HOLE



ET01J1AVBE2
Vertical Actuation
SPDT

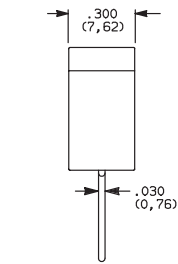

Actuator Shown In Pos. 1

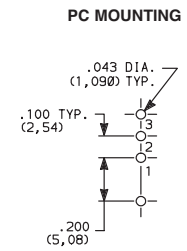
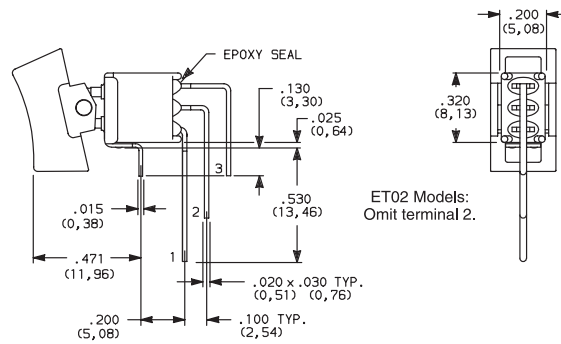

NOTE: Terminal bend radii and lead-in manufacturing option.

AV VERTICAL RIGHT ANGLE, PC THRU-HOLE



ET21J1AVBE2
Vertical Actuation
DPDT

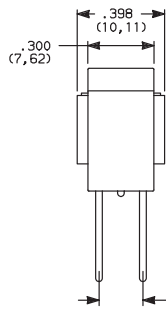

Actuator Shown In Pos. 1

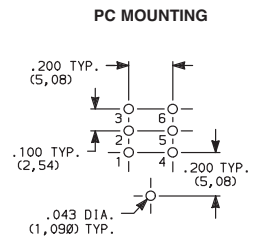
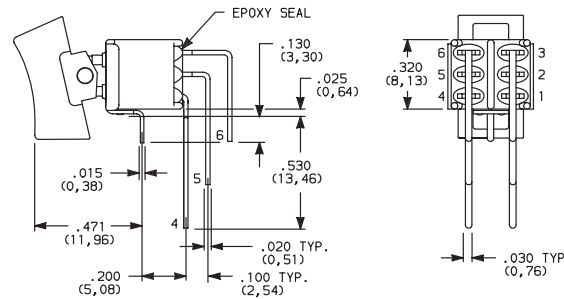

NOTE: Terminal bend radii and lead-in manufacturing option.

AV2 VERTICAL RIGHT ANGLE, PC THRU-HOLE



ET01J1AV2BE2
Vertical Actuation
SPDT

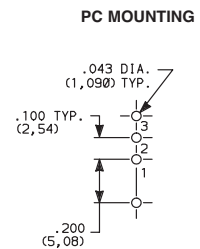
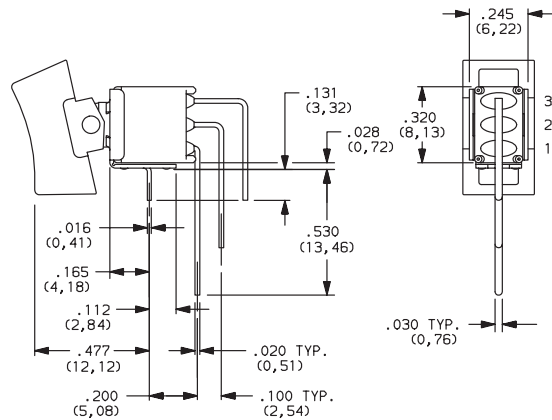
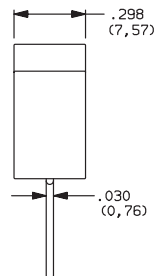

Rocker



G

C&K

Third Angle Projection

Dimensions are shown: Inches (mm)
Specifications and dimensions subject to change

ET Series Sealed Subminiature Rocker Switches

TERMINATIONS

SA RIGHT ANGLE, SURFACE MOUNT

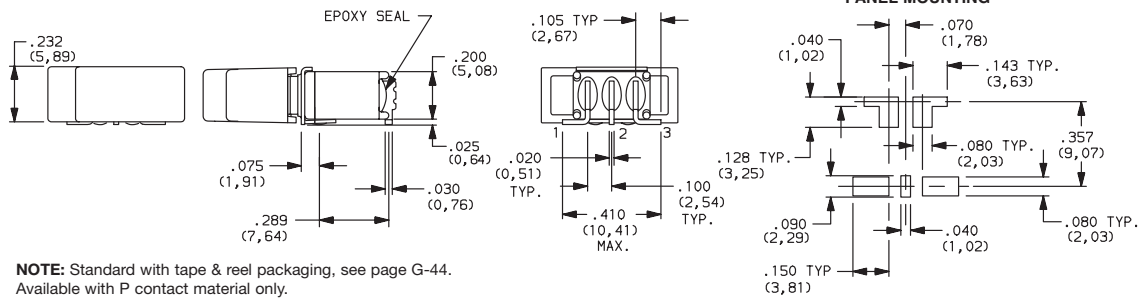

ET01J6SAPE2
Horizontal Actuation
SPDT

V3 VERTICAL MOUNT, V-BRACKET

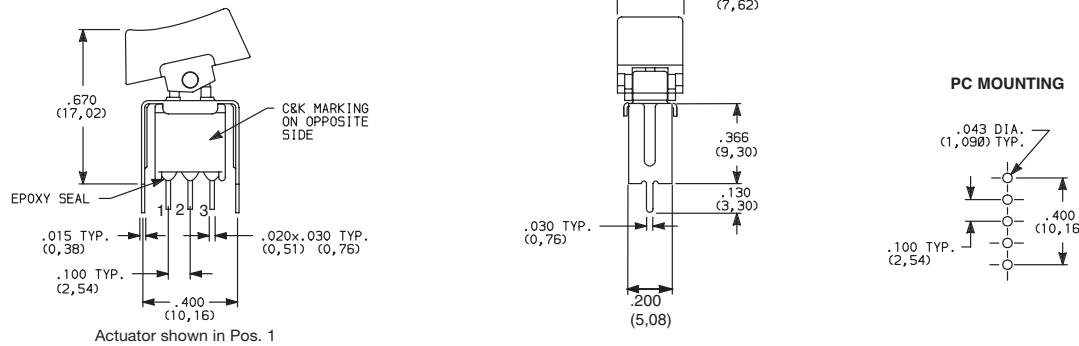

ET01J1V3BE2
SPDT

V3 VERTICAL MOUNT, V-BRACKET

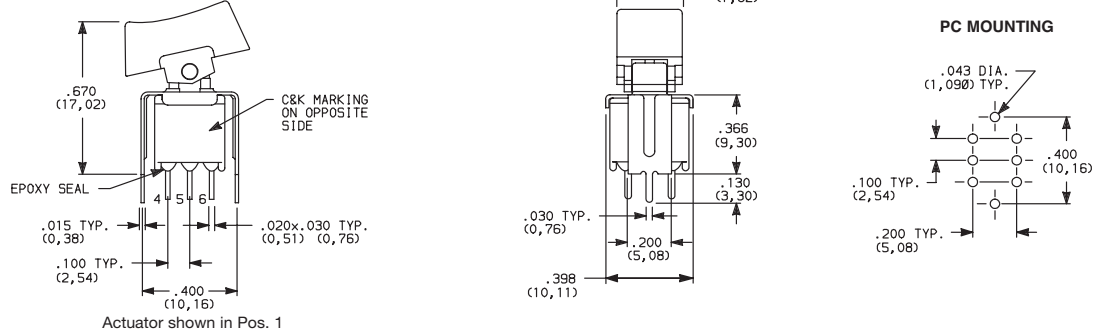

ET21J1V3BE2
DPDT

CONTACT MATERIAL

| OPTION CODE | CONTACT MATERIAL | TERMINAL PLATING | RATINGS | |
|-------------|------------------------------------|------------------------|-----------------------------------|---|
| | | | | |
| B | GOLD ¹ | GOLD ¹ | LOW LEVEL/ DRY CIRCUIT | 0.4 VA MAX. @ 20 V AC OR DC MAX. |
| P | | MATTE-TIN ⁶ | | |
| Q | SILVER ^{4,5} | SILVER ⁵ | POWER | ETX1 MODELS: 3 AMPS @ 120 V AC OR 28 V DC. ALL OTHER MODELS: 2 AMPS @ 120 V AC OR 28 V DC. |
| S | | MATTE-TIN ⁶ | | |
| G | GOLD OVER SILVER ^{2,3} | GOLD ³ | LOW LEVEL/DRY CIRCUIT OR POWER | ETX1 MODELS: 0.4 VA MAX @ 20 V AC OR DC MAX. OR 3 AMPS @ 120 V AC OR 28 V DC. ALL OTHER MODELS: 0.4 VA MAX @ 20 V AC OR DC MAX. OR 2 AMPS @ 120 V AC OR 28 V DC. |
| R | | MATTE-TIN ⁶ | | |

* Note: See Technical Data section of this catalog for RoHS compliant and compatible definitions and specifications.

¹ CONTACTS & TERMINALS: Copper alloy, with gold plate over nickel plate.

² END CONTACTS: Coin silver, with gold plate over nickel plate.

³ CENTER CONTACTS & ALL TERMINALS: Copper alloy, with gold plate over nickel plate.

⁴ END CONTACTS: Coin silver, silver plated.

⁵ CENTER CONTACT & ALL TERMINALS: Copper alloy, silver plated.

⁶ TERMINALS: Copper alloy, with matte-tin over nickel plate.

NOTE: Any models supplied with Q, B, G, S, P & R contact material are RoHS compliant.

All models  with all options when ordered with G, Q, S & R contact material.

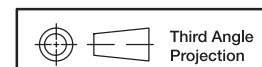

Dimensions are shown: Inches (mm)
Specifications and dimensions subject to change



ET Series Sealed Subminiature Rocker Switches



E EPOXY SEAL

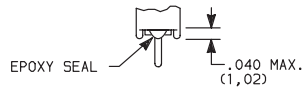

AVAILABLE HARDWARE

J1 Actuator



PART NO.
261A01000 WHITE
261A02263 BLACK
261A03000 RED

Material: Nylon
 Finish: Matte
 NOT AVAILABLE WITH A, SA, SA1

J6 Actuator



PART NO.
621C01000 WHITE
621C02263 BLACK
621C03000 RED

Material: Nylon
 Finish: Matte
 For Hi Temp, Consult Factory

NOTE: Other colors available, consult Customer Service Center.

TAPE & REEL SA TERMINATION

ET01J6SABE (SHOWN)

| REEL INFORMATION | |
|-------------------|---------------|
| OUTSIDE DIAMETER | 13.00 (330,0) |
| PILOT HOLE | .512 (13,0) |
| QUANTITY PER REEL | 500 |

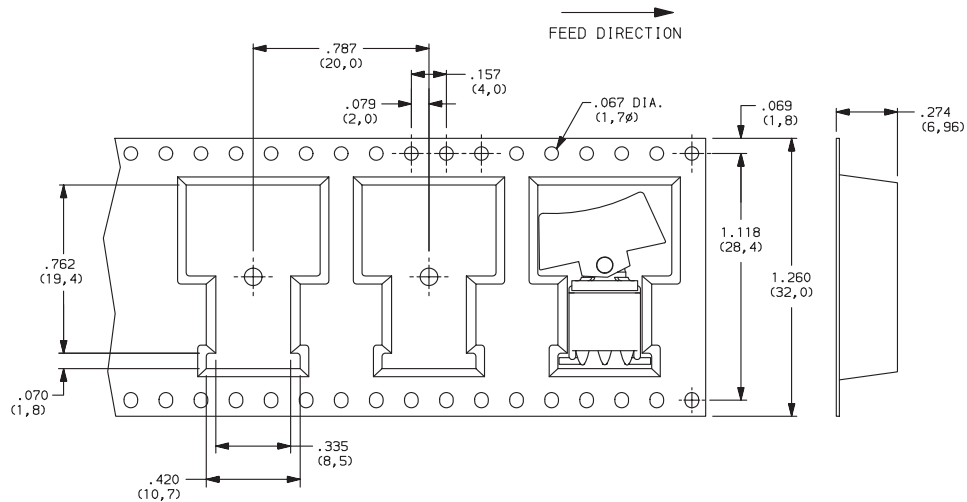

ET01J6SA1BE (SHOWN)

| REEL INFORMATION | |
|-------------------|---------------|
| OUTSIDE DIAMETER | 13.00 (330,0) |
| PILOT HOLE | .795 (20,2) |
| QUANTITY PER REEL | 450 |

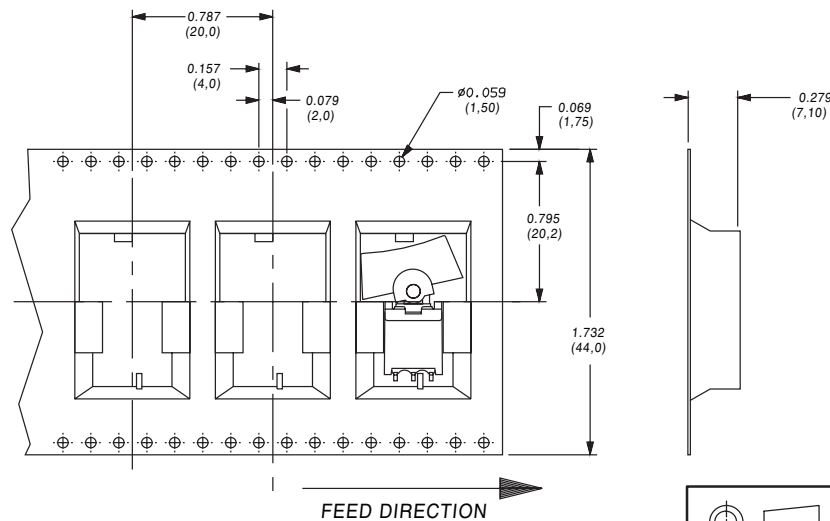

Rocker



G



Dimensions are shown: Inches (mm)
 Specifications and dimensions subject to change

T Series Subminiature Rocker Switches

Features/Benefits

- **Compact size—small footprint**
- **Single and double pole models**
- **PC and panel mounting options available**
- **RoHS compliant**

Typical Applications

- **Telecommunications**
- **Instrumentation**
- **Medical Equipment**



Models Available

Specifications

CONTACT RATING: Q contact material (TX01 models): 3 AMPS @ 120 V AC or 28 V DC. All other models: 2 AMPS @ 120 V AC or 28 V DC. See page G-49 for additional ratings.

ELECTRICAL LIFE: TX01 models: 60,000 make-and-break cycles at full load. All other models: 30,000 cycles.

CONTACT RESISTANCE: Below 20 m Ω typ. initial @ 2–4 V DC, 100 mA, for both silver and gold plated contacts.

INSULATION RESISTANCE: 10⁹ Ω min.

DIELECTRIC STRENGTH: 1000 Vrms min. @ sea level.

OPERATING TEMPERATURE: –30°C to 85°C.

SOLDERABILITY: Per MIL-STD-202F method 208D, or EIA RS-186E method 9 (1 hour steam aging).

NOTE: Any models supplied with B, G, P, Q or R contact material are RoHS compliant.

NOTE: Specifications and materials listed above are for switches with standard options. For information on specific and custom switches, consult Customer Service Center.

Materials

CASE: Glass filled nylon 6/6, flame retardant, heat stabilized or diallyl phthalate (DAP), (UL 94V-0) or glass filled nylon 4/6, flame retardant, heat stabilized.

ACTUATOR: Nylon, black standard.

BUSHING: Brass, nickel plated.

HOUSING: Stainless steel.

SWITCH SUPPORT: Brass, matte-tin plated.

MOUNTING BRACKET: Stainless steel.

END CONTACTS: B contact material: Copper alloy, with gold plate over nickel plate. Q contact material: Coin silver, silver plated. See page G-49 for additional contact materials.

CENTER CONTACTS & TERMINALS: B contact material: Copper alloy, with gold plate over nickel plate. Q contact material: Copper alloy, silver plated. See page G-49 for additional contact materials.

TERMINAL SEAL: Epoxy.

HARDWARE: Nut, Screws & Lockwasher: Stainless steel.
Standoff: Nylon standard.





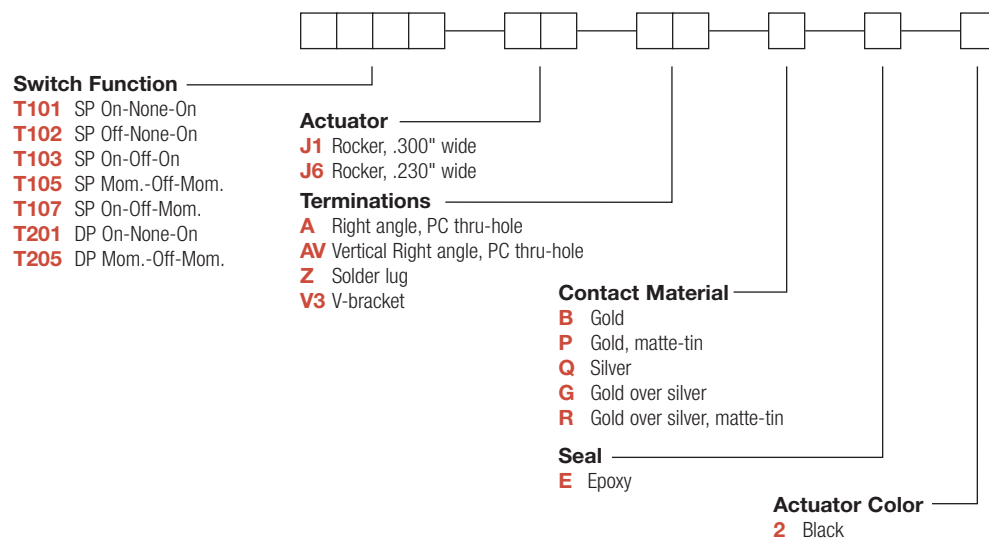

Build-A-Switch

To order, simply select desired option from each category and place in the appropriate box. Available options are shown and described on pages G-46 through G-50. For additional options not shown in catalog, consult Customer Service Center. All models have epoxy terminal seal and are compatible with all “bottom-wash” PCB cleaning methods.

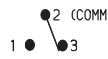

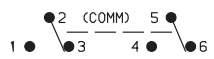
T Series Subminiature Rocker Switches

SWITCH FUNCTION 

| NO. POLES | MODEL NO. | SWITCH FUNCTION | | | CONNECTED TERMINALS | | | SCHEMATIC |
|--|-------------|---|---|---|---|---|--|--|
| | | POS. 1 | POS. 2 | POS. 3 | POS. 1 | POS. 2 | POS. 3 | |
| | |  |  |  |  |  |  | |
| | | C&K marking on opposite side | | | C&K marking on opposite side | | | |
| SP | T101 | ON | NONE | ON | 2-3 | N/A | 2-1 | SPDT  |
| | T103 | ON | OFF | ON | | OPEN | | |
| | T105 | MOM. | OFF | MOM. | | | | 3-1 |
| | T107 | ON | OFF | MOM. | | | | |
| | T102 | OFF | NONE | ON | | | | |
| <p>SPDT</p> <div style="display: flex; justify-content: space-around;"> <div data-bbox="299 725 705 1020"> </div> <div data-bbox="758 680 1023 1020"> <p>Terminal Nos. For Reference Only</p> </div> <div data-bbox="1076 748 1464 952"> </div> </div> <p>Part number shown: T101J6ZBE2</p> | | | | | | | | |

T Series Subminiature Rocker Switches

ACTUATOR

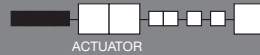

J1 ROCKER, .300 WIDE

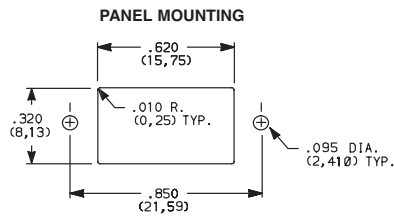
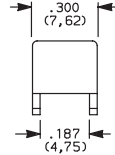
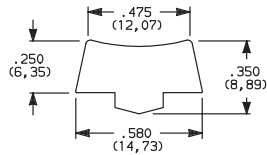

| OPTION CODE | ACTUATOR COLOR |
|-------------|----------------|
| 2 | BLACK |

Actuators available separately, see page G 50. Finish: Matte. Other colors, custom actuator markings and legends available, consult Customer Service Center.

Standard with all models except T10X with A terminations.

J6 ROCKER, .230 WIDE

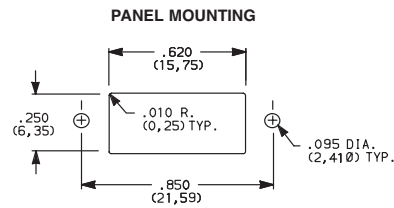
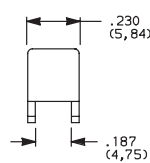
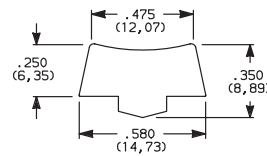

Standard with T10X model with A terminations.

TERMINATIONS



Z SOLDER LUG

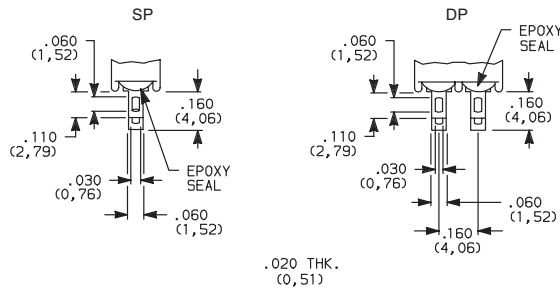

SP and DP

Not available with P or R contact material.

A RIGHT ANGLE, PC THRU-HOLE

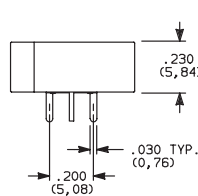

Actuator Shown In Pos. 1

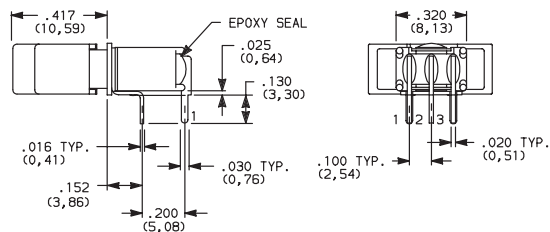

PC MOUNTING

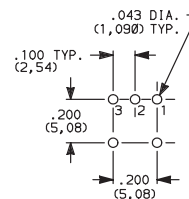

T101J6ABE2
Horizontal Actuation
SPDT

Rocker



T Series Subminiature Rocker Switches

TERMINATIONS



A RIGHT ANGLE, PC THRU-HOLE



T201J1ABE2
Horizontal Actuation
DPDT

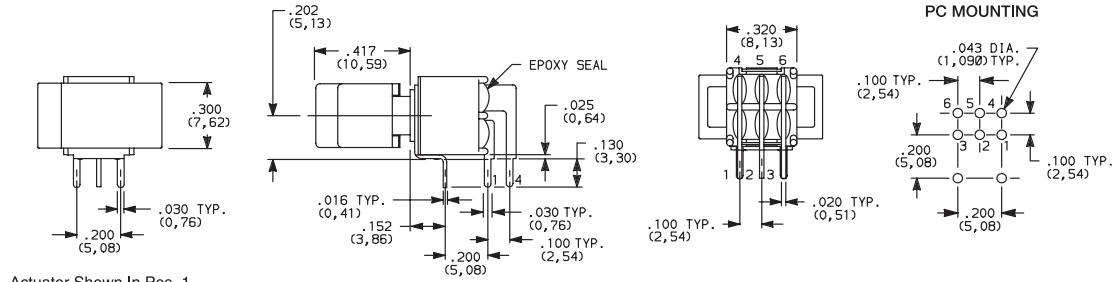

AV VERTICAL RIGHT ANGLE, PC THRU-HOLE



T101J1AVBE2
Vertical Actuation
SPDT

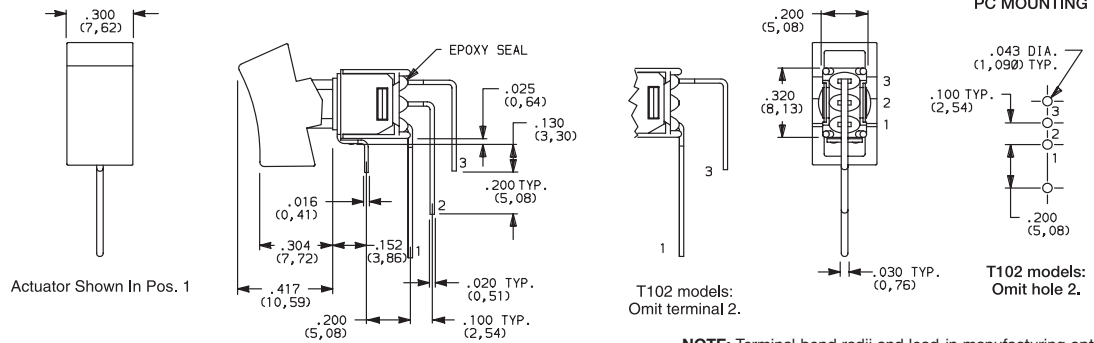

NOTE: Terminal bend radii and lead-in manufacturing option.

AV VERTICAL RIGHT ANGLE, PC THRU-HOLE



T201J1AVBE2
Vertical Actuation
DPDT

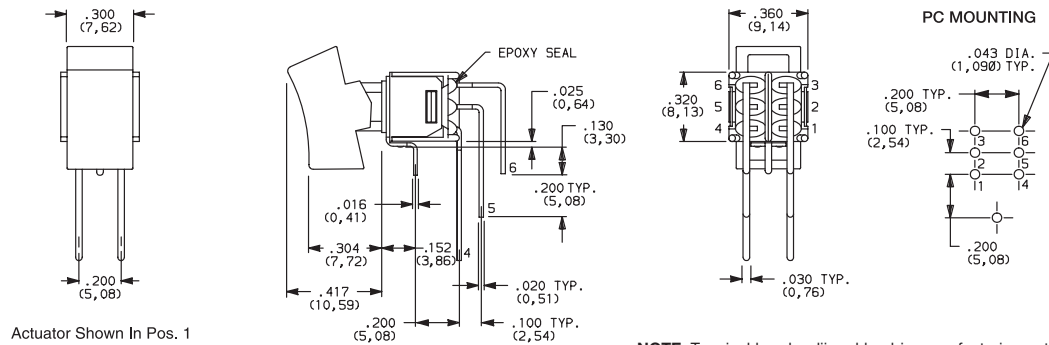

NOTE: Terminal bend radii and lead-in manufacturing option.

V3 VERTICAL MOUNT, V-BRACKET



T101J1V3BE2
SPDT

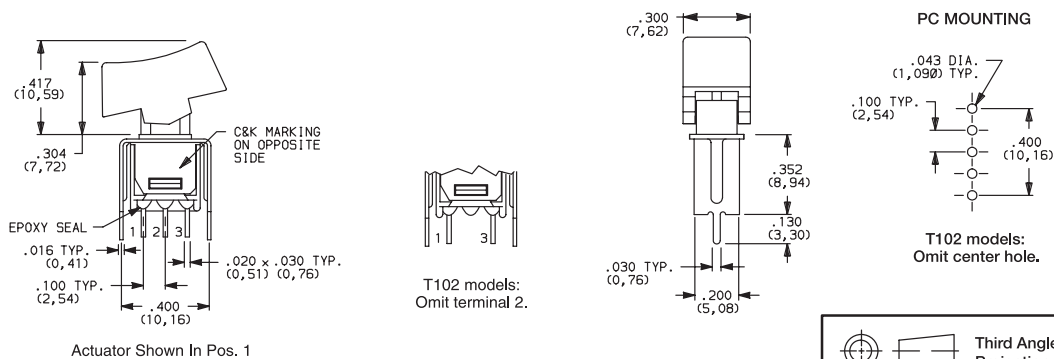

Dimensions are shown: Inches (mm)
Specifications and dimensions subject to change

www.ck-components.com

Rocker



G



T Series Subminiature Rocker Switches

TERMINATIONS

V3 VERTICAL MOUNT, V-BRACKET

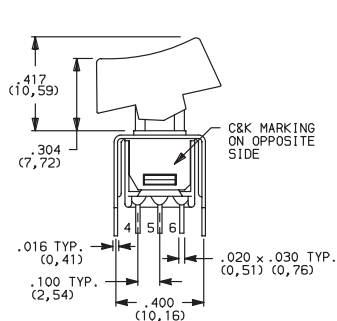

Actuator Shown In Pos. 1

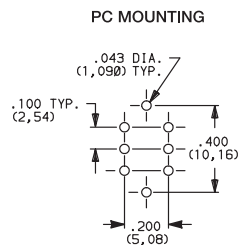
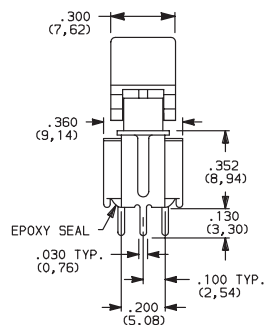

T201J1V3BE2
DPDT

CONTACT MATERIAL

| OPTION CODE | CONTACT MATERIAL | TERMINAL PLATING | RATINGS | |
|-------------|------------------------------------|------------------------|-----------------------------------|---|
| B | GOLD ³ | GOLD ¹ | LOW LEVEL/ DRY CIRCUIT | 0.4 VA MAX. @ 20 V AC OR DC MAX. |
| P | | MATTE-TIN ⁶ | | |
| Q | SILVER ^{4,5} | SILVER ⁵ | POWER | TX01 MODELS: 3 AMPS @ 120 V AC OR 28 V DC. ALL OTHER MODELS: 2 AMPS @ 120 V AC OR 28 V DC. |
| G | GOLD OVER SILVER ^{2,3} | GOLD ³ | LOW LEVEL/DRY CIRCUIT OR POWER | TX01 MODELS: 0.4 VA MAX @ 20 V AC OR DC MAX. OR 3 AMPS @ 120 V AC OR 28 V DC. ALL OTHER MODELS: 0.4 VA MAX @ 20 V AC OR DC MAX. OR 2 AMPS @ 120 V AC OR 28 V DC. |
| R | | MATTE-TIN ⁶ | | |

* Note: See Technical Data section of this catalog for RoHS compliant and compatible definitions and specifications.

- ¹ CONTACTS & TERMINALS: Copper alloy, with gold plate over nickel plate.
- ² END CONTACTS: Coin silver, with gold plate over nickel plate.
- ³ CENTER CONTACTS & ALL TERMINALS: Copper alloy, with gold plate over nickel plate.
- ⁴ END CONTACTS: Coin silver, silver plated.
- ⁵ CENTER CONTACT & ALL TERMINALS: Copper alloy, silver plated.
- ⁶ TERMINALS: Copper alloy, with matte-tin over nickel plate.

NOTE: Any models supplied with B, G, P, Q & R contact material are RoHS compliant.

All models  with all options when ordered with G, Q, or R contact material.
B contact material standard with A, AV, V3 terminations.
Q contact material standard with C & Z terminations.

P & R contact materials not available with Z terminations.

SEAL

E EPOXY SEAL

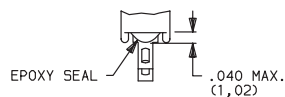

T Series Subminiature Rocker Switches

AVAILABLE HARDWARE

Panel mounting hardware for rocker and lever handle switches is available separately. Mounting hardware consists of two screws, two nuts, two standoffs and two lockwashers per switch, and is available for panel thicknesses of 1/16, 3/32 and 1/8 inch. See part numbers below.

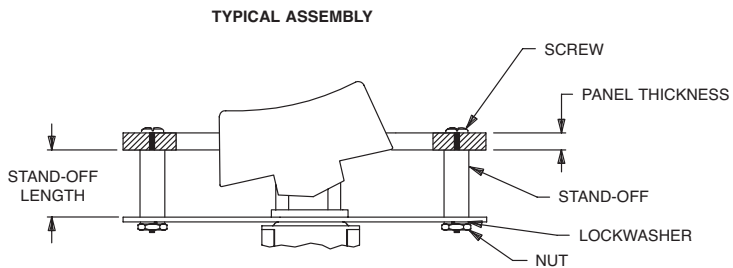

| PART NO. | PANEL THK. | STANDOFF LENGTH |
|-----------|-----------------|-----------------|
| 761101000 | 1/16 IN. (1,59) | .295 (7,49) |
| 761102000 | 3/32 IN. (2,38) | .264 (6,71) |
| 761103000 | 1/8 IN. (3,18) | .233 (5,92) |

NOTE: Additional nuts, screws and lockwashers available separately, see Technical Data section of this catalog.

J1 Actuator



PART NO.
468002263 BLACK

Material: Nylon
Finish: Matte

J6 Actuator



PART NO.
468102263 BLACK

Material: Nylon
Finish: Matte

NOTE: Other colors, custom actuator markings and legends available, consult Customer Service Center.

Rocker



Third Angle
Projection

Dimensions are shown: Inches (mm)
Specifications and dimensions subject to change

9000 Series Power Rocker and Lever Handle Switches



Features/Benefits

- **Thermoset UL 94V-0 housing**
- **Rugged construction**
- **Variety of actuator and termination options**
- **RoHS compliant**

Typical Applications

- **Small equipment**
- **Shut-off switch**

UL 61058-1



Specifications

CONTACT RATING:

9201 Model:

- GP (general purpose)
- 6 AMPS 125 VAC 50/60 Hz T85 10,000 cycles (10E3)
- 3 AMPS 250 VAC 50/60 Hz T85 10,000 cycles
- R (resistive)
- 6 AMPS 30 VDC T85 10,000 cycles

9221 Model:

- GP (general purpose)
- 10 AMPS 125 VAC 50/60 Hz T85 10,000 cycles
- 5 AMPS 250 VAC 50/60 Hz T85 10,000 cycles
- R (resistive)
- 10 AMPS 30 VDC T85 10,000 cycles

ELECTRICAL LIFE: 25,000 make-and-break cycles at full load.

CONTACT RESISTANCE: Below 10 m Ω typ. initial @ 2-4 V DC, 100 mA.

INSULATION RESISTANCE: 10⁹ Ω min.

DIELECTRIC STRENGTH: 2,500 Vrms min. @ sea level.

OPERATING TEMPERATURE: -30°C to 85°C.

SOLDERABILITY: Per MIL-STD-202F method 208D, or EIA RS-186E method 9 (1 hour steam aging).

Materials

CASE: Diallyl phthalate (DAP) (UL 94V-0).

ACTUATOR: Nylon, black standard.

FRAME-REAR MOUNT OPTIONS: Spring steel, black.

BUSHING: Brass, nickel plated.

HOUSING: Stainless steel.

SWITCH SUPPORT: Brass or steel, matte-tin plated.

MOUNTING BRACKET: Stainless steel.

END CONTACTS: 9201 Model: Coin silver, silver plated.

9221 Model: Silver cadmium oxide.

CENTER CONTACTS: Copper alloy, silver plated

ALL TERMINALS: 9201 Model: Copper alloy, silver plated.

9221 Model: Copper alloy, matte-tin plated.

TERMINAL SEAL: Epoxy.

HARDWARE: Nut, Screw & Lockwasher: Stainless steel. Standoff: Nylon standard, aluminum available, consult Customer Service Center.

*Cadmium used in electrical contacts is acceptable for RoHS.

NOTE: Any models supplied with Q contact material are RoHS compliant.

NOTE: Specifications and materials listed above are for switches with standard options. For information on specific and custom switches, consult Customer Service Center.

Build-A-Switch

To order, simply select desired option from each category and place in the appropriate box. Available options are shown and described on pages G-52 through G-55. For additional options not shown in catalog, consult Customer Service Center.

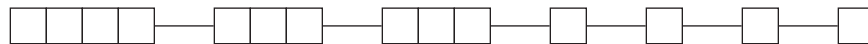

Switch Function

- 9201** DP On-On, 6 Amps
- 9221** DP On-On, 10 Amps

Actuator

- J1** Rocker
- J2** Lever
- J3** Rocker
- J37** Rocker with metal frame

Terminations

- Z** Solder lug (9201 only)
- AV2** Vertical right angle, PC thru-hole (9201 only)
- C** PC Thru-hole (9201 only)
- Z4** Quick connect

Contact Material

- Q** Silver

Seal

- E** Epoxy
- D** No Seal

Actuator Color

- 2** Black
- 1** White
- 3** Red

Frame Color

- 2** Black
- NONE** No frame color required



9000 Series Power Rocker and Lever Handle Switches

SWITCH FUNCTION

| NO. POLES | MODEL NO. | RATING* | SWITCH FUNCTION | | CONNECTED TERMINALS | | SCHEMATIC |
|-----------|-----------|---------|-----------------|--------|---------------------|---------|-----------|
| | | | POS. 1 | POS. 2 | POS. 1 | POS. 2 | |
| DP | 9201 | 6 AMPS | ON | ON | 2-3,5-6 | 2-1,5-4 | |
| | 9221 | 10 AMPS | ON | ON | | | |

DPDT

Terminal Nos. Molded On Side Of Case

Part number shown: 9201J1ZQE2

All 9000 Series models meet international dimensional and electrical requirements.

* See CONTACT MATERIAL, page G-54, for complete ratings.

9221 model must be ordered with Z4 terminations and D seal option.

ACTUATOR-PANEL MOUNT

| OPTION CODE | ACTUATOR COLOR |
|-------------|----------------|
| 2 | BLACK |
| 1 | WHITE |
| 3 | RED |

Finish: Matte. Other colors, custom actuator markings and legends available, consult Customer Service Center.

NOTE: Hardware: two each—mounting screws, nuts, lockwashers and standoffs for 1/8 inch thick panel are supplied standard on all switches with panel mounting brackets. Actuators available separately, see page G-55. Hardware available separately, see Technical Data section of this catalog.

PANEL MOUNTING

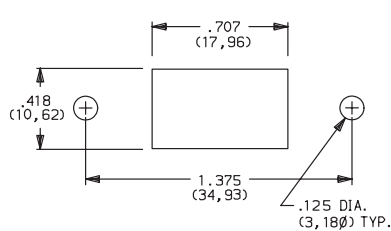

J1 ROCKER

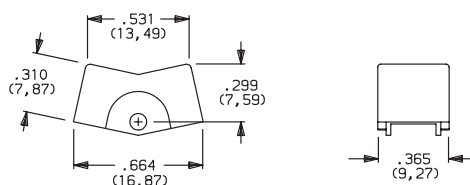

J2 LEVER

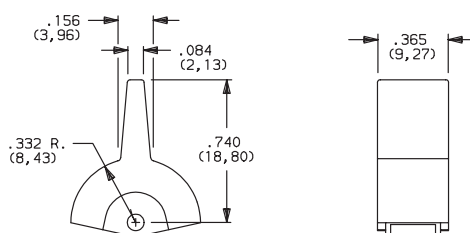

Rocker



G

C&K



Dimensions are shown: Inches (mm)
Specifications and dimensions subject to change

9000 Series Power Rocker and Lever Handle Switches

ACTUATOR-PANEL MOUNT

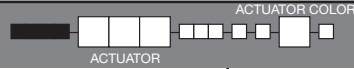

J3 ROCKER

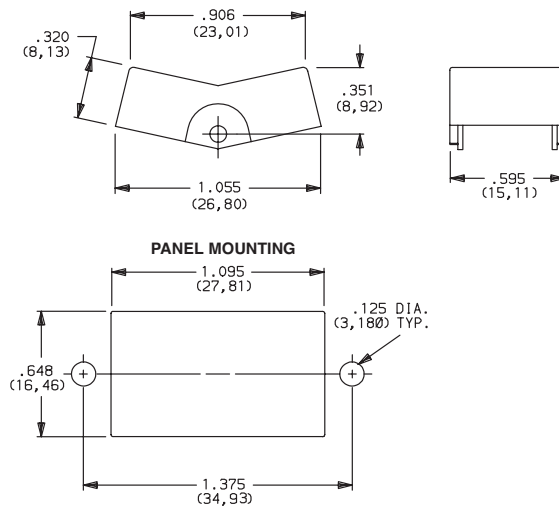

| OPTION CODE | ACTUATOR COLOR |
|-------------|----------------|
| 2 | BLACK |
| 1 | WHITE |
| 3 | RED |

Actuator finish: Matte. Other colors, custom actuator markings and legends available, consult Customer Service Center.

NOTE: Actuators available separately, see page G-55. Hardware: two each—mounting screws, nuts, lockwashers and standoffs for 1/8 inch thick panel are supplied standard on all switches with panel mounting brackets. Hardware available separately, see Technical Data section of this catalog.

ACTUATOR-REAR MOUNT

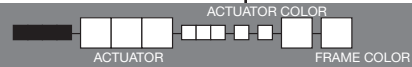

J37 ROCKER WITH METAL FRAME

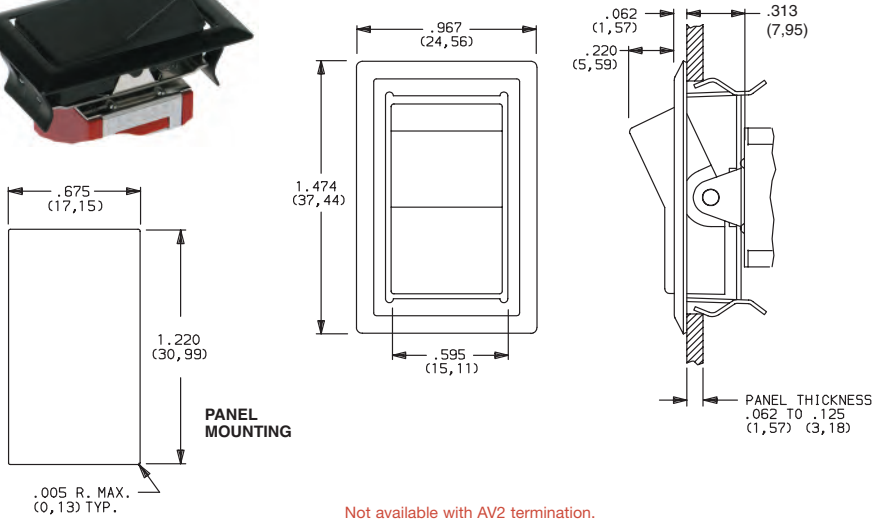

| OPTION CODE | ACTUATOR COLOR |
|-------------|----------------|
| 2 | BLACK |
| 1 | WHITE |
| 3 | RED |

| OPTION CODE | FRAME COLOR |
|-------------|-------------|
| 2 | BLACK |

Actuator finish: Matte. Frame finish: Gloss. Other colors, custom actuator markings and legends available, consult Customer Service Center.

NOTE: Actuators & frames available separately, see page G-55. Hardware: two each—mounting screws, nuts, lockwashers and standoffs for 1/8 inch thick panel are supplied standard on all switches with panel mounting brackets. Hardware available separately, see Technical Data section of this catalog.

TERMINATIONS



Z SOLDER LUG

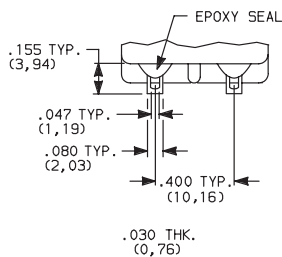

9201 Only

C PC THRU-HOLE

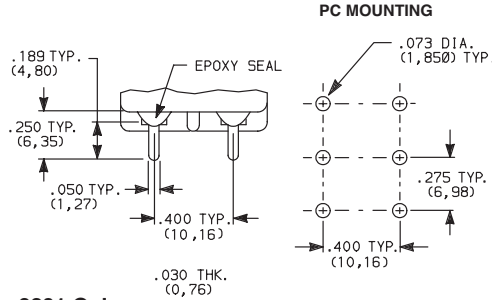

9201 Only

Z4 QUICK CONNECT

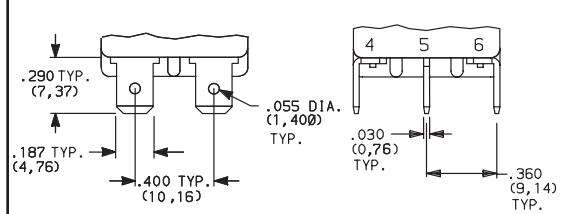

9201 and 9221

NOTE: Only termination available with 9221 model. Must be ordered with D seal option. Mating terminal standard Nema .187" quick connect.

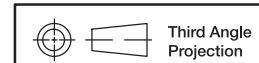

Third Angle Projection



9000 Series Power Rocker and Lever Handle Switches

TERMINATIONS

AV2 VERTICAL RIGHT ANGLE, PC THRU-HOLE

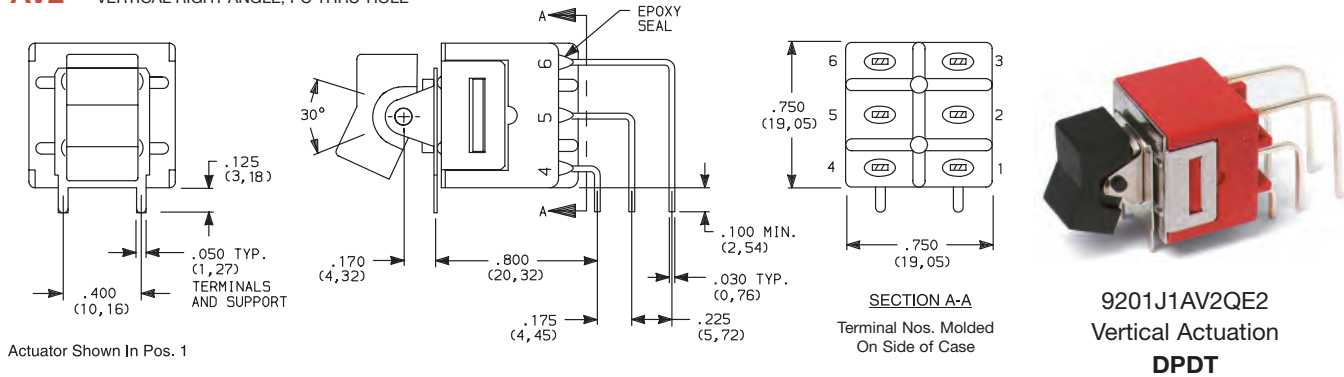

PC MOUNTING

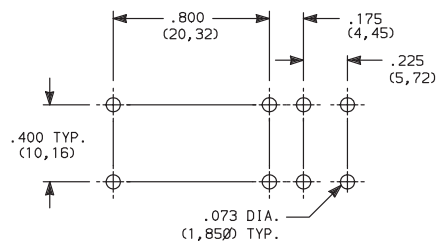

9201 Only

NOTE: Terminal bend radii and lead-in manufacturing option. Terminal spacing greater than 3mm at all points.

CONTACT MATERIAL

| OPTION CODE | MODEL | CONTACT MATERIAL | TERMINAL PLATING | RATINGS |
|-------------|-------|----------------------------|-------------------|---|
| Q | 9201 | SILVER 1,2 | SILVER OR TIN 2,5 | GP (general purpose) 6 AMPS 125 VAC 50/60 Hz T85 10,000 cycles (10E3) 3 AMPS 250 VAC 50/60 Hz T85 10,000 cycles R (resistive) 6 AMPS 30 VDC T85 10,000 cycles |
| | 9221 | SILVER CADMIUM OXIDE 3,4,6 | TIN 5 | GP (general purpose) 10 AMPS 125 VAC 50/60 Hz T85 10,000 cycles 5 AMPS 250 VAC 50/60 Hz T85 10,000 cycles R (resistive) 10 AMPS 30 VDC T85 10,000 cycles |

* Note: See Technical Data section of this catalog for RoHS compliant and compatible definitions and specifications.

- 1 END CONTACTS: Coin silver, silver plated.
- 2 CENTER CONTACTS & ALL TERMINALS: Copper alloy, silver plated.
- 3 END CONTACTS: Silver cadmium oxide.
- 4 CENTER CONTACTS: Copper alloy, silver plated.
- 5 Z4 TERMINALS ONLY: Copper alloy, tin plated.
- 6 Cadmium used for electrical contacts is acceptable for RoHS.

NOTE: Any models supplied with Q contact material is RoHS compliant.

9221 model must be ordered with Z4 terminations and D seal option.

All 9000 Series models meet international dimensional and electrical requirements.



SEAL

E EPOXY SEAL

D NO EPOXY SEAL

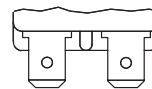
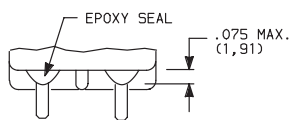

Not available with 9221 model or Z4 terminations.

Must be ordered with 9221 model and Z4 termination.

Rocker



G

C&K



Dimensions are shown: Inches (mm)
Specifications and dimensions subject to change

9000 Series Power Rocker and Lever Handle Switches

AVAILABLE HARDWARE

Panel mounting hardware for rocker and lever handle switches is available separately. Mounting hardware consists of two screws, two nuts, two standoffs and two lockwashers per switch, and is available for panel thicknesses of 1/16, 3/32 and 1/8 inch. See part numbers below.

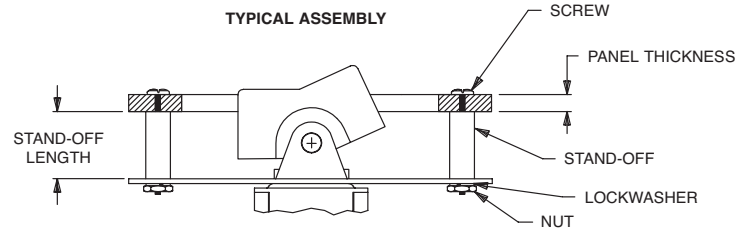

J1 & J2 actuators

| PART NO. | PANEL THK. | STANDOFF LENGTH |
|-----------|-----------------|-----------------|
| 761101000 | 1/16 IN. (1,59) | .295 (7,49) |
| 761102000 | 3/32 IN. (2,38) | .264 (6,71) |
| 761103000 | 1/8 IN. (3,18) | .233 (5,92) |

J1 Actuator

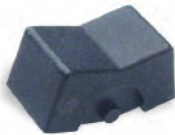

PART NO.
776A01000 WHITE
776A02263 BLACK
776A03000 RED

Material: Nylon
 Finish: Matte

J2 Actuator



PART NO.
760501000 WHITE
760502263 BLACK
760503000 RED

Material: Nylon
 Finish: Matte

J3, J37 Actuators



PART NO.
766601000 WHITE
766602263 BLACK
766603000 RED

Material: Nylon
 Finish: Matte

Frame for J37 Actuators



PART NO.
445400746 BLACK ENAMEL
445400747 WHITE ENAMEL

Material: Spring Steel

NOTE: Additional nuts, screws and lockwashers available separately, see Technical Data section of this catalog.

Other colors available, consult Customer Service Center.

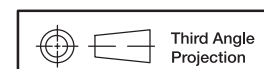

Dimensions are shown: Inches (mm)
 Specifications and dimensions subject to change



DA Series Miniature Single Pole Rocker Switches

Features/Benefits

- Nice actuator styling with multiple options
- Guards to prevent accidental actuation
- Momentary and maintained functions
- IP65 splash proof rubber boot option
- RoHS compliant

Typical Applications

- Small appliances
- Computers and peripherals
- Medical instrumentation



UL 61058-1

Specifications

CONTACT RATING:

- 16 AMPS @ 125 VAC, 1/3 HP;
- 10 AMPS @ 250 VAC, 1/2 HP.
- 10 AMPS @ 125 VAC, 6 AMPS @ 250 VAC.

ELECTRICAL LIFE: 10,000 make and break cycles at full load.

INSULATION RESISTANCE: $10^8 \Omega$ min.

DIELECTRIC STRENGTH: 1,500 VRMS @ sea level.

OPERATING TEMPERATURE: -20°C to +85°C

Materials

HOUSING AND ACTUATOR: 6/6 nylon (UL94V-2), black, matte finish.

ILLUMINATED ACTUATOR: Polycarbonate, matte finish.

CENTER CONTACTS: Silver plated, copper alloy.

END CONTACTS: Silver plated.

ALL TERMINALS: Silver plated, copper alloy.

NOTE: Specifications and materials listed above are for switches with standard options. For information on specific and custom switches, consult Customer Service Center.

Build-A-Switch

To order, simply select desired option from each category and place in the appropriate box. Available options are shown and described on pages G-57 through G-59. For additional options not shown in catalog, consult Customer Service Center.

| | | | | | | | | | | | | | | | | | | | | | | | | | | | | | |
|--------------------------|--|--------------------------|--|-----------------------------|--|--------------------------|--|--------------------------|--|--------------------------|--|--------------------------|--|--------------------------|--|---------------------------------|--|--------------------------|--|----------------------------|--|------------------------------|--|--------------------------|--|---------------------|--|---------|--|
| <input type="checkbox"/> | | <input type="checkbox"/> | | <input type="checkbox"/> | | <input type="checkbox"/> | | <input type="checkbox"/> | | <input type="checkbox"/> | | <input type="checkbox"/> | | <input type="checkbox"/> | | <input type="checkbox"/> | | <input type="checkbox"/> | | <input type="checkbox"/> | | | | | | | | | |
| Switch Function | | | | | | | | | | | | | | | | | | | | | | | | | | | | | |
| DA101 | | SPDT On-None-On | | Actuator | | J1 | | Rocker | | J2 | | Two-tone rocker | | *J3 | | Illuminated rocker | | J4 | | Circle, illuminated rocker | | J5 | | Oval, illuminated rocker | | | | | |
| DA102 | | SPST On-None-Off | | Actuator Color | | 1-5 | | See Chart on Page G-59 | | *R | | Red, illuminated | | *A | | Amber, illuminated | | *G | | Green, illuminated | | | | | | | | | |
| DA103 | | SPDT On-Off-On | | Mounting Style/Color | | S2 | | Snap-in, black | | S1 | | Snap-in, white | | B2 | | Recessed snap-in bracket, black | | G2 | | Guard, black | | Termination | | 15 | | .187" quick connect | | | |
| | | | | | | 17 | | Solder lug | | 02 | | Thru-hole | | A | | Right angle | | Actuator Marking | | (NONE) | | No marking | | D | | ON-OFF | | | |
| | | | | | | | | | | | | | | | | | | | | H | | "O I" - international ON-OFF | | N | | Large dot | | | |
| | | | | | | | | | | | | | | | | | | | | P | | "O -" international ON-OFF | | Contact Rating | | QF | | Silver | |
| | | | | | | | | | | | | | | | | | | | | | | | | Lamp Rating | | (NONE) | | No lamp | |
| | | | | | | | | | | | | | | | | | | | | | | | | 6 | | LED | | | |
| | | | | | | | | | | | | | | | | | | | | | | | | 7 | | 125 VAC neon | | | |
| | | | | | | | | | | | | | | | | | | | | | | | | 8 | | 250 VAC neon | | | |

* "J3" illuminated switches are not available with actuator markings

Rocker

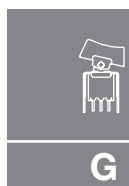

Dimensions are shown: Inches (mm)
Specifications and dimensions subject to change

DA Series Miniature Single Pole Rocker Switches

SWITCH FUNCTION

| NO. POLES | MODEL NO. | SWITCH FUNCTION | | | CONNECTED TERMINALS | | | SCHEMATIC |
|-----------|--------------|-----------------|------|-----|---------------------|-----|-----|---|
| | | | | | | | | |
| SP | DA101 | ON | NONE | ON | 2-3 | N/A | 2-1 | |
| | DA102 | ON | NONE | OFF | | | | OR For 7 & 8 Illuminated Versions Only |
| | DA103 | ON | OFF | ON | | | | For 6 Illuminated Versions Only |

Shown in Pos. 1

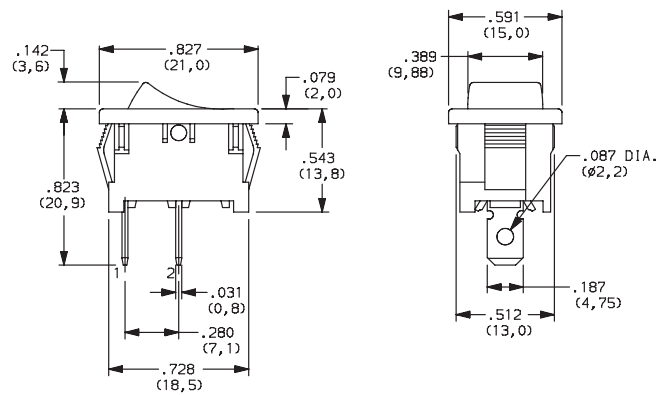

ACTUATOR

- J1** ROCKER
- *J3** ILLUMINATED ROCKER

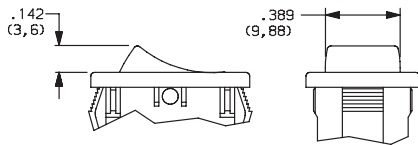

NOTE: J3 actuator available with DA102 switch functions, 7&8 lamp ratings and not available with O2 and A termination options.

* J3 actuator not available with markings

- J2** TWO-TONE ROCKER

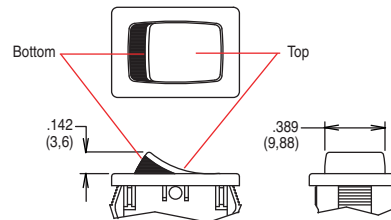

NOTE:

1. Available with DA102 switch function only.
2. Available with None or P actuator marking options only.



DA Series Miniature Single Pole Rocker Switches

ACTUATOR

J4 CIRCLE, ILLUMINATED ROCKER

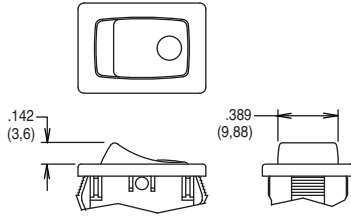

NOTE: Available with DA102 switch function and 7 & 8 lamp ratings combinations only. Not available with O2 and A termination options.

J5 OVAL, ILLUMINATED ROCKER

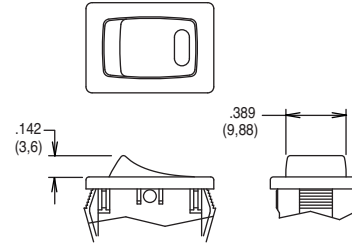

NOTE: Available with DA102 switch function and 6 lamp rating combinations only. Not available with O2 and A termination options.

ACTUATOR COLOR

| | OPTION CODE | ACTUATOR COLOR |
|------------------------|-------------|--------------------|
| J1 only | 2 | BLACK |
| | 1 | WHITE |
| | 3 | RED |
| J3, J4, J5 only | R | RED, ILLUMINATED |
| | A | AMBER, ILLUMINATED |
| | G | GREEN, ILLUMINATED |

| | OPTION CODE | ACTUATOR COLOR | |
|----------------|-------------|----------------|--------|
| | | TOP | BOTTOM |
| J2 only | 1 | WHITE | RED |
| | 2 | WHITE | BLACK |
| | 3 | RED | WHITE |
| | 4 | BLACK | WHITE |
| | 5 | BLACK | RED |

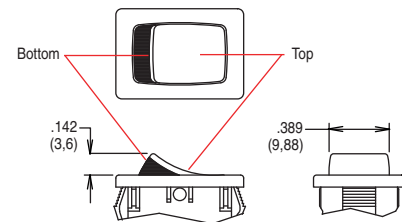

MOUNTING STYLE/COLOR

S2 SNAP-IN, BLACK

S1 SNAP-IN, WHITE

G2 GUARD, BLACK

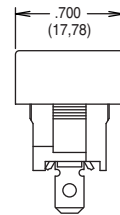
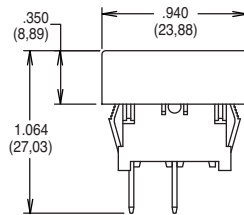
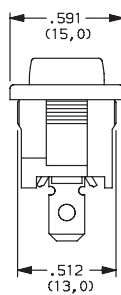
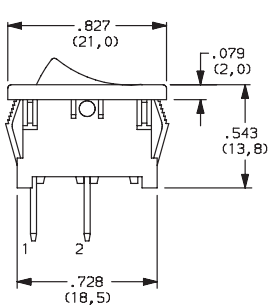

S2, S1 & G2 PANEL MOUNTING

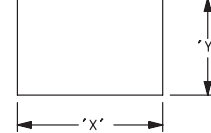

| PANEL THICKNESS | "X" | "Y" |
|-------------------------|-----------------------|-----------------------|
| 0.030-0.049 (0,75-1,25) | 0.756-.004 (19,2-0,1) | 0.512+.004 (13,0+0,1) |
| 0.049-0.079 (1,25-2,0) | 0.764-.004 (19,4-0,1) | 0.512+.004 (13,0+0,1) |
| 0.079-0.118 (2,0-3,0) | 0.779-.004 (19,8-0,1) | 0.512+.004 (13,0+0,1) |

NOTE: Available with DA10X switch functions only.

Actuator shown in Pos. 1

B2 RECESSED SNAP-IN BRACKET, BLACK

B2 PANEL MOUNTING

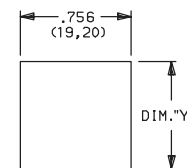
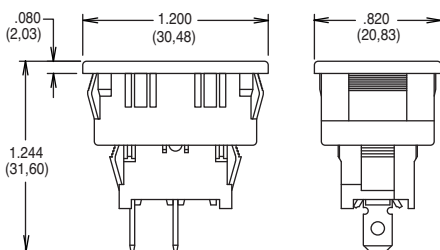

| PANEL THICKNESS | "Y" |
|-------------------------|---------------|
| 0.030-0.049 (0,75-0,25) | 1.068 (27,13) |
| 0.049-0.079 (1,25-2,0) | 1.076 (27,33) |
| 0.079-0.118 (2,0-3,0) | 1.092 (27,74) |

NOTE: Available with DA10X switch functions only.

Rocker



G

C&K



Third Angle Projection

Dimensions are shown: Inches (mm)
Specifications and dimensions subject to change

DA Series Miniature Single Pole Rocker Switches

TERMINATION

15 .187" QUICK CONNECT

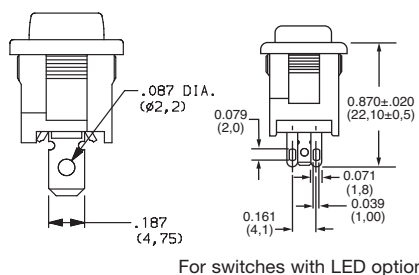
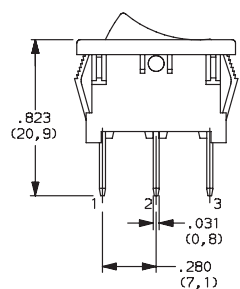

For switches with LED option

17 SOLDER LUG

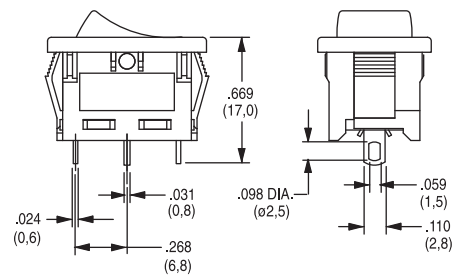

02* THRU-HOLE

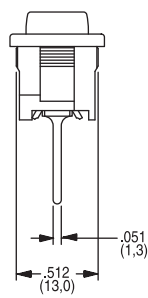
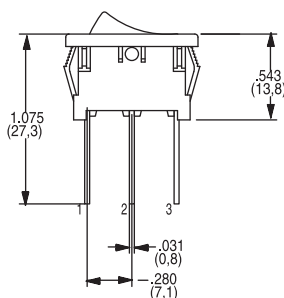

A* RIGHT ANGLE

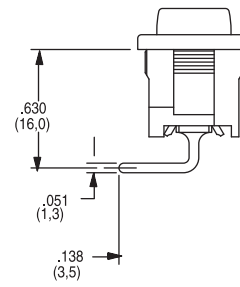
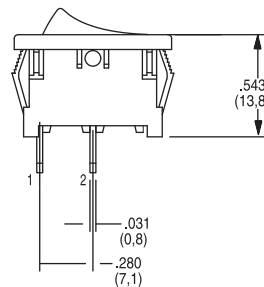

* NOTE - O2 and A termination options not offered with J3, J4 or J5 actuator options.

ACTUATOR MARKING

NONE NO MARKING



D ON-OFF

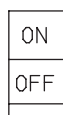

H O I

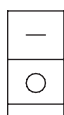

N LARGE DOT



P O -

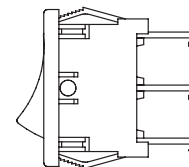
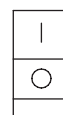

All models shown in Pos. 1
Markings not available with J3 actuator

NOTE: Orientation of actuator marking and terminals.

CONTACT MATERIAL

| OPTION CODE | CONTACT AND TERMINAL MATERIAL | RATINGS | |
|-------------|-------------------------------|---------|--|
| QF | SILVER | POWER | 16 AMPS @ 125 VAC; 1/3 HP; 10 AMPS @ 250 VAC; 1/2 10 AMPS @ 125 VAC, 6 AMPS @ 250 VAC |

* Note: See Technical Data section of this catalog for RoHS compliant and compatible definitions and specifications.

LAMP RATING

(NONE) NO LAMP

6 LED RATING @ 10 mA $V_f=1.85V$

7 125 VAC 33kΩ NEON

8 250 VAC 150kΩ NEON

ACCESSORIES

216C0000 IP65 SPLASH PROOF RUBBER BOOT

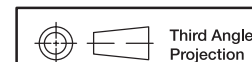
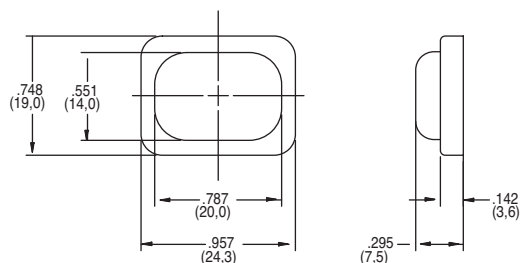

Third Angle
Projection

Dimensions are shown: Inches (mm)
Specifications and dimensions subject to change



D Series Miniature Snap-in Power Rocker Switches

Features/Benefits

- Momentary and maintained models
- PC and quick connect terminals
- Recessed bracket available — prevents accidental actuation
- RoHS compliant
- Gold plated options available

Typical Applications

- Small appliances
- Computers and peripherals
- Medical instrumentation



UL 61058-1



Specifications

CONTACT RATING:

D101, D102, D103, D105, D108, D201, D202, D203

GP (general purpose)

4 AMPS 125 VAC 50/60 Hz T85 10,000 cycles

2 AMPS 250 VAC 50/60 Hz T85 10,000 cycles

R (resistive)

4 AMPS 30 VDC T85 10,000 cycles

D501, D502, D503, D508, D601, D602, D608

GP (general purpose)

10 AMPS 125 VAC 50/60 Hz T85 10,000 cycles

5 AMPS 250 VAC 50/60 Hz T85 10,000 cycles

R (resistive)

10 AMPS 30 VDC T85 10,000 cycles

0.4VA @ 20V AC/DC (gold plating) available upon request

ELECTRICAL LIFE: 10,000 make-and-break cycles at full load.

INSULATION RESISTANCE: $10^9 \Omega$ min.

DIELECTRIC STRENGTH: 1,000 Vrms min. @ sea level.

Materials

ACTUATOR & HOUSING: 6/6 nylon (UL 94V-2), color black, finish: matte.

MOVABLE CONTACTS: D10X and D20X Models: Copper, silver plated. D50X and D60X Models: Coin silver, silver plated.

STATIONARY CONTACTS AND TERMINALS: Copper or brass, silver plated. Gold plating available.

CONTACT SPRING: Music wire or stainless steel.

OPERATING TEMPERATURE: -30°C to +65°C

NOTE: Specifications and materials listed above are for standard switches. For information on specific and custom switches, consult Customer Service Center.

Build-A-Switch

To order, simply select desired option from each category and place in the appropriate box. Available options are shown and described on pages G-61 through G-64. For additional options not shown in catalog, consult Customer Service Center.

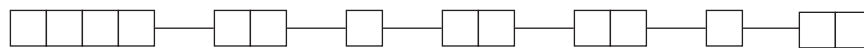

Switch Function

- D101** SPDT, On-None-On
- D102** SPST, On-None-Off
- D103** SPDT, On-Off-On
- D105** SPDT, Mom.-Off-Mom.
- D108** SPDT, Mom.-None-On
- D201** DPDT, On-None-On
- D202** DPST, On-None-Off
- D203** DPDT, On-Off-On
- D501** SPDT, On-None-On
- D502** SPST, On-None-Off
- D503** SPDT, On-Off-On
- D508** SPDT, Mom.-None-On
- D601** DPDT, On-None-On
- D602** DPST, On-None-Off
- D608** DPDT, Mom.-None-On

Actuator

- J1** Rocker
- J5** Lever

Actuator Color

- 2** Black
- 1** White
- 3** Red

Mounting Style/Color

- S2** Snap-in, black
- B2** Recessed snap-in actuator guard, black
- G2** Actuator guard, black
- S1** Snap-in, white

Terminations

- 15** Quick connect
- A** Right angle, PC thru-hole
- 02** PC Thru-hole
- 05** Twisted quick connect
- 06** Extended PC thru-hole
- 17** Wirable quick connect

Actuator Markings

- NONE** No marking
- D** ON-OFF
- H** 0 I
- N** Large dot
- P** 0 -
- R** Red rectangle on end
- U** Large dot on end

Contact Material

- QA** Silver
- Gold plating options available contact Customer Service

Rocker

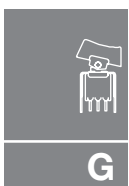

Dimensions are shown: Inches (mm)
Specifications and dimensions subject to change

D Series Miniature Snap-in Power Rocker Switches

SWITCH FUNCTION

| NO. POLES | MODEL NO. | AMP RATING* | SWITCH FUNCTION | | | CONNECTED TERMINALS | | | SCHEMATIC | | |
|-----------|---|-------------|-----------------|--------|--------|---------------------|--------|------------|-----------|------|------|
| | | | POS. 1 | POS. 2 | POS. 3 | POS. 1 | POS. 2 | POS. 3 | | | |
| SP | D102 D502 | 4 10 | ON | NONE | OFF | 1-1A | N/A | OPEN | SPST | | |
| | D101 D501 | 4 10 | ON | NONE | ON | | | 1-1B | OPEN | SPDT | |
| | D103 D503 | 4 10 | | OFF | | | | | | | |
| | D105 | 4 | MOM. | OFF | MOM. | | | | | | |
| | D108 D508 | 4 10 | MOM. | NONE | ON | | | | | | |
| | <p>SPDT</p> <p>ACTUATOR SHOWN IN POSITION 1</p> <p>Part number shown: D101J12S215QA</p> <p>TERMINAL NOS. FOR REF. ONLY</p> | | | | | | | | | | |
| DP | D202 D602 | 4 10 | ON | NONE | OFF | 1-1A, 2-2A | N/A | | | | OPEN |
| | D201 D601 | 4 10 | ON | NONE | ON | | | 1-1B, 2-2B | OPEN | DPDT | |
| | D203 | 4 | | OFF | | | | | | | |
| | D608 | 10 | MOM. | NONE | | | | | | | |
| | <p>DPDT</p> <p>ACTUATOR SHOWN IN POSITION 1</p> <p>Part number shown: D201J12S215QA</p> <p>TERMINAL NOS. FOR REF. ONLY</p> | | | | | | | | | | |

MOM. = Momentary

*AMP RATING: see G-60

See CONTACT MATERIALS, page G-64.

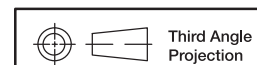

Third Angle Projection
Dimensions are shown: Inches (mm)
Specifications and dimensions subject to change



D Series Miniature Snap-in Power Rocker Switches



J1 ROCKER

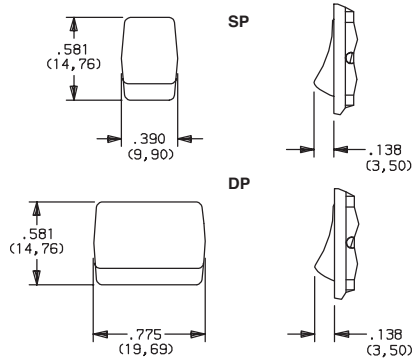

J5 LEVER

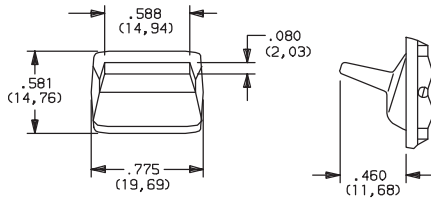

| OPTION CODE | ACTUATOR COLOR |
|-------------|----------------|
| 2 | BLACK |
| 1 | WHITE |
| 3 | RED |

NOTE: Actuator finish: matte. Other colors available, consult Customer Service Center.

'J5' actuator available only with DP models D201, D202, D601 and D602.



S SNAP-IN

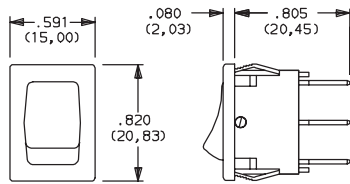

| OPTION CODE | HOUSING COLOR |
|-------------|---------------|
| 2 | (STD.) BLACK |
| 1 | WHITE |

NOTE: Frame finish on housing: matte. Other colors available, consult Customer Service Center.

B2 RECESSED SNAP-IN ACTUATOR GUARD, BLACK

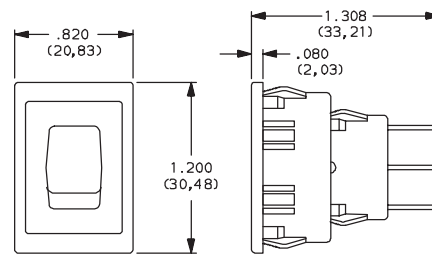

NOTE: Vertical mount, SP models only.

G2 ACTUATOR GUARD, BLACK

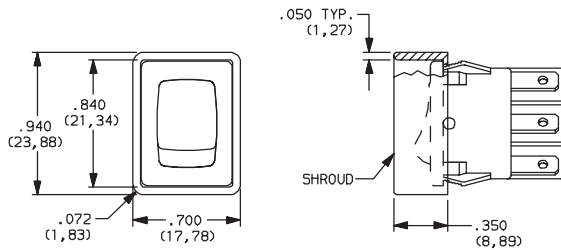

NOTE: Vertical mount, SP models only.

PANEL MOUNTING

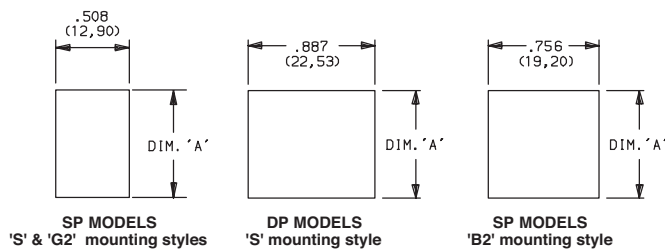

| PANEL THICKNESS | DIM 'A' SP & DP MODELS 'S' MOUNTING STYLE | DIM 'A' WITH 'G2' OPTION SP MODELS ONLY | DIM 'A' SP MODELS 'B' MOUNTING STYLE |
|-------------------------|---|---|--------------------------------------|
| .030-.049 (0,76) (1,24) | .756 (19,20) | .764 (19,41) | 1.068 (27,13) |
| .049-.079 (1,24) (2,01) | .764 (19,41) | .780 (19,81) | 1.076 (27,33) |
| .079-.118 (2,01) (3,00) | .780 (19,81) | n/a | 1.092 (27,74) |

NOTE: Blank insert available for SP models only, see page G-64.

Rocker



G



Dimensions are shown: Inches (mm)
Specifications and dimensions subject to change

www.ck-components.com

D Series Miniature Snap-in Power Rocker Switches

TERMINATIONS

A RIGHT ANGLE, PC THRU-HOLE

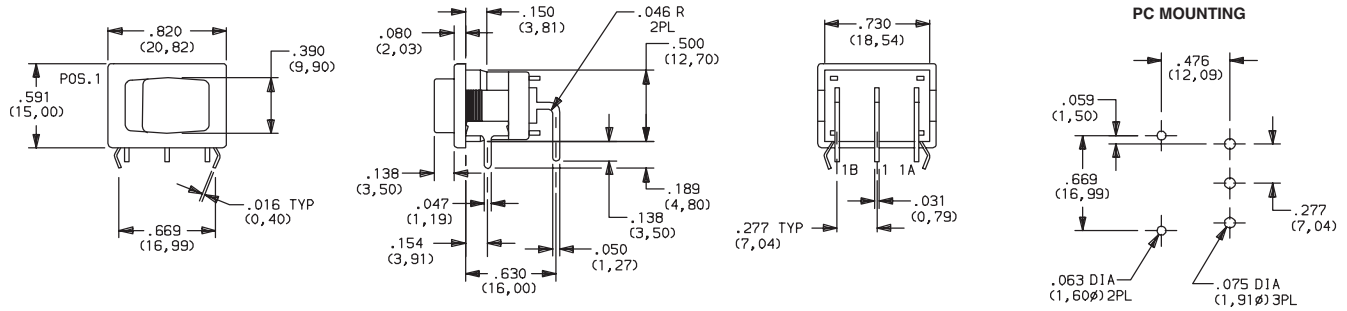

Available with D101, D102, D501, D502 SP models only.

TERMINATIONS

02 PC THRU-HOLE

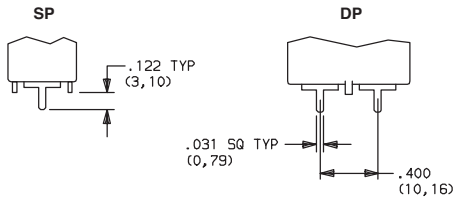

06 EXTENDED PC THRU-HOLE

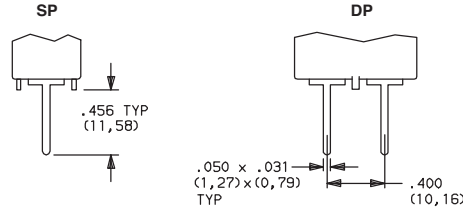

PC MOUNTING (02 and 06)

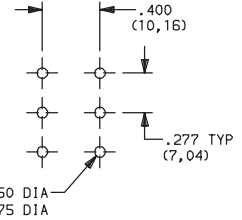

Available with DX01 and DX02 models only.

Available with DX01 and DX02 models only.

15 QUICK CONNECT

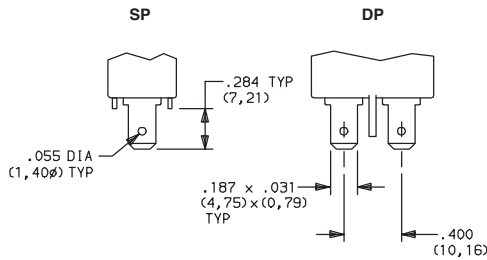

05 TWISTED QUICK CONNECT

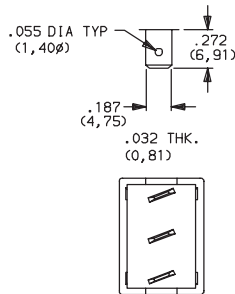

17 WIRABLE QUICK CONNECT

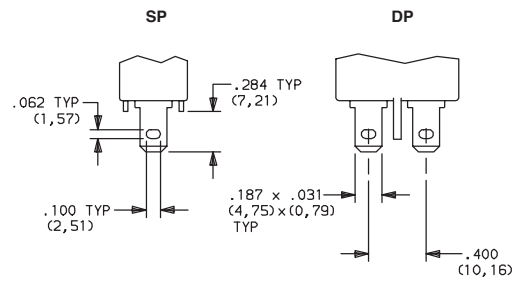

Available with DX01 and DX02 models only.

NOTE: Terminals are twisted.

Available with DX01 and DX02 models only.

ACTUATORS

NONE NO MARKING

D ON-OFF

H O |

N LARGE DOT

P O -

R RED RECTANGLE
ON END

U LARGE DOT ON END

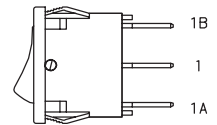

'D, H, P & U' marking options: marking color white, standard for all actuator colors except white. Black marking color, standard for white actuators. 'R & N' marking option: red marking color, standard. Consult Customer Service Center for other available marking colors.

NOTE: Orientation of actuator markings and terminals.

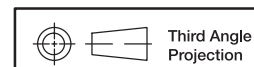

Third Angle
Projection

Dimensions are shown: Inches (mm)
Specifications and dimensions subject to change



D Series Miniature Snap-in Power Rocker Switches

CONTACT MATERIAL

| OPTION CODE | CONTACT AND TERMINAL MATERIAL | RATINGS |
|-------------|-------------------------------|---|
| QA | SILVER 1 | D101, D102, D103, D105, D108, D201, D202, D203 |
| | | GP (general purpose) 4 AMPS 125 VAC 50/60 Hz T85 10,000 cycles |
| | | 2 AMPS 250 VAC 50/60 Hz T85 10,000 cycles |
| | | R (resistive) 4 AMPS 30 VDC T85 10,000 cycles |
| | | D501, D502, D503, D508, D601, D602, D608 |
| | | GP (general purpose) 10 AMPS 125 VAC 50/60 Hz T85 10,000 cycles |
| | | 5 AMPS 250 VAC 50/60 Hz T85 10,000 cycles |
| | | R (resistive) 10 AMPS 30 VDC T85 10,000 cycles |

¹MOVABLE CONTACT: D10X and D20X MODELS: Copper, silver plated.
D50X and D60X MODELS: Coin silver, silver plated.



0.4VA @ 20V AC/DC Gold plated options available contact Customer Service.

STATIONARY CONTACTS & TERMINALS: Copper or brass, silver plated.

AVAILABLE HARDWARE

Insert
SP Only

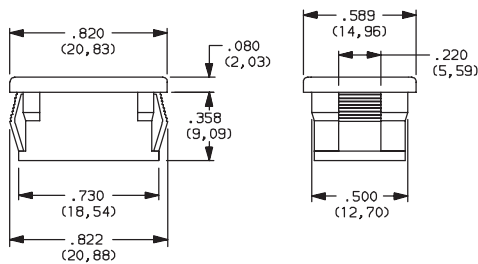

PART NO.

057190200 BLACK

Material: Nylon 6/6
Finish: Matte

Recessed Actuator Guard,
SP Only



599D02000 BLACK

Material: 6/6 Nylon
Finish: Matte

Actuator Guard

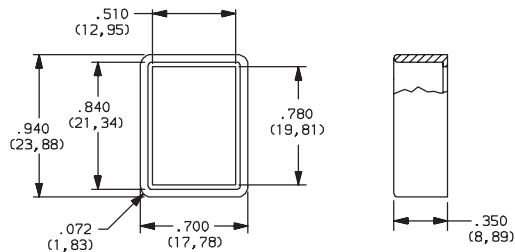

PART NO.

104C22000

Material: PBT thermoplastic
Finish: Matte

PART NO.

216C00000 IP65 SPLASH PROOF RUBBER BOOT

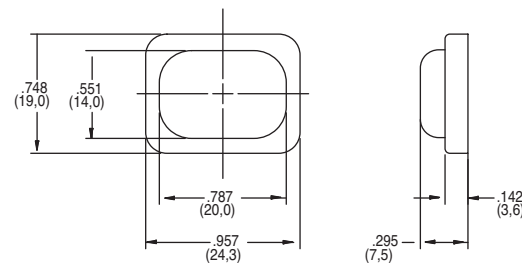

Rocker



G

C&K



Third Angle
Projection

Dimensions are shown: Inches (mm)
Specifications and dimensions subject to change

DM Series Miniature 2 Pole Power Rocker Switches



Features/Benefits

- 3 AMPS to 10 AMPS
- Quick connect terminals
- Double pole in miniature size
- Recessed bracket available—prevents accidental actuation
- RoHS compliant

Typical Applications

- Computers
- Appliances
- Electric tools

UL 61058-1



Specifications

CONTACT RATING:

DM21, DM22:

GP (general purpose)

3 AMPS 125 VAC 50/60 Hz T85 10,000 cycles

2 AMPS 250 VAC 50/60 Hz T85 10,000 cycles

R (resistive)

3 AMPS 30 VDC T85 10,000 cycles

DM61, DM62:

GP (general purpose)

10 AMPS 125 VAC 50/60 Hz T85 10,000 cycles

5 AMPS 250 VAC 50/60 Hz T85 10,000 cycles

R (resistive)

10 AMPS 30 VDC T85 10,000 cycles

ELECTRICAL LIFE: 10,000 make-and-break cycles at full load.

INSULATION RESISTANCE: $10^9 \Omega$ min.

DIELECTRIC STRENGTH: 1,000 Vrms min. @ sea level.

OPERATING TEMPERATURE: -20°C to +65°C

Materials

HOUSING & ACTUATOR: 6/6 nylon (UL94V-2), black.

MOVABLE CONTACTS: DM2X Models: Copper, silver plated.

DM6X Models: Coin silver, silver plated.

STATIONARY CONTACTS & TERMINALS: Copper or brass, silver plated.

CONTACT SPRING: Music wire or stainless steel.

NOTE: Any models supplied with Q contact material are RoHS compliant.

NOTE: Specifications and materials listed above are for standard switches. For information on specific and custom switches, consult Customer Service Center.

Build-A-Switch

To order, simply select desired option from each category and place in the appropriate box. Available options are shown and described on pages G-66 and G-68. For additional options not shown in catalog, consult Customer Service Center.

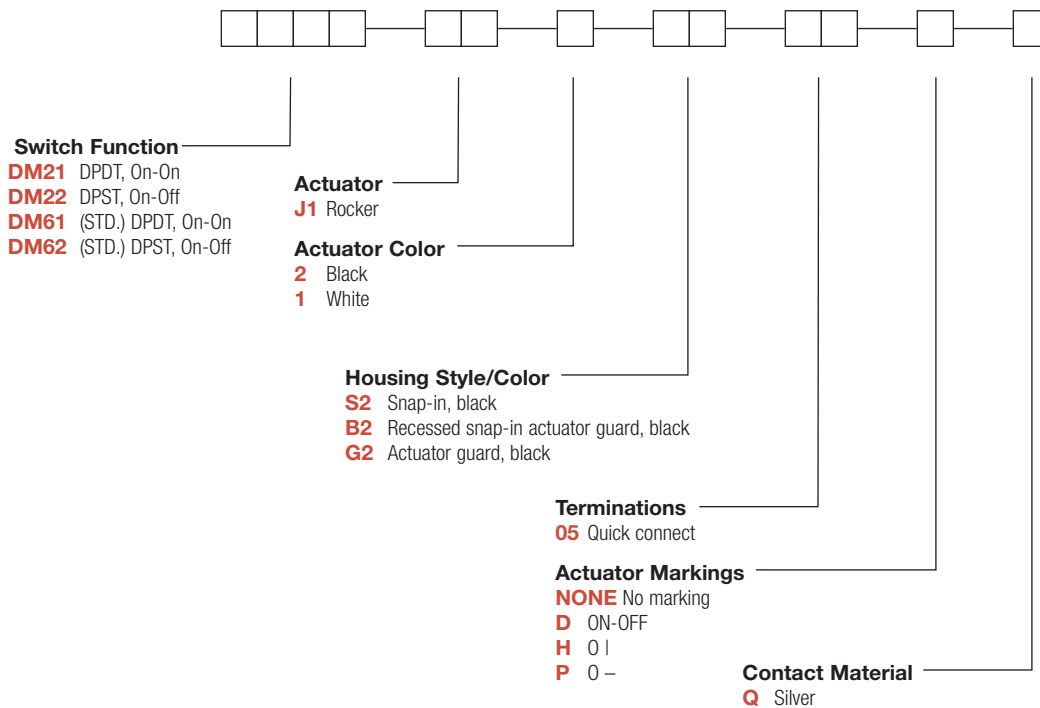

2 aug 16



DM Series Miniature 2 Pole Power Rocker Switches

SWITCH FUNCTION

| NO. POLES | MODEL NO. | AMP RATING* | SWITCH FUNCTION | | CONNECTED TERMINALS | | SCHEMATIC |
|-----------|-------------|-------------|-----------------|--------|---------------------|------------|-----------|
| | | | POS. 1 | POS. 2 | POS. 1 | POS. 2 | |
| DP | DM22 | 3 | ON | OFF | 1-1A, 2-2A | OPEN | DPST |
| | DM62 | 10 | ON | OFF | 1-1A, 2-2A | OPEN | |
| | DM21 | 3 | ON | ON | 1-1A, 2-2A | 1-1B, 2-2B | DPDT |
| | DM61 | 10 | ON | ON | 1-1A, 2-2A | 1-1B, 2-2B | |

DPDT

PART NUMBER SHOWN: DM21J1XS205Q

NOTES 1. ACTUATOR SHOWN IN POSITION 1-'ON' POSITION

RATINGS: See page G-65 for complete ratings.

UL 15 UL 61058-1 tested to 30C temperature rise @ 6,000 cycles.

ACTUATOR

J1 ROCKER

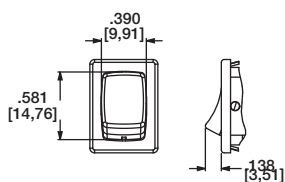

| OPTION CODE | ACTUATOR COLOR |
|-------------|----------------|
| 2 | BLACK |
| 1 | WHITE |

NOTE: Actuator finish: matte. Other colors available, consult Customer Service Center.

HOUSING STYLE/COLOR

S2 SNAP-IN, BLACK

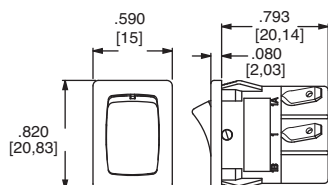

B2 RECESSED SNAP-IN ACTUATOR GUARD, BLACK

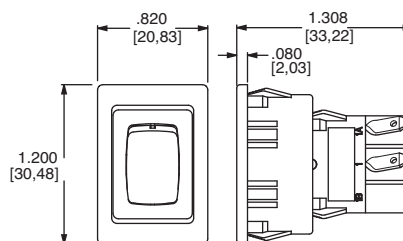

Rocker

NOTE: Housing finish: matte. Other colors available, consult Customer Service Center.



Dimensions are shown: Inches (mm)
Specifications and dimensions subject to change



2 aug 16

DM Series Miniature 2 Pole Power Rocker Switches

HOUSING STYLE/COLOR

G2 ACTUATOR GUARD, BLACK

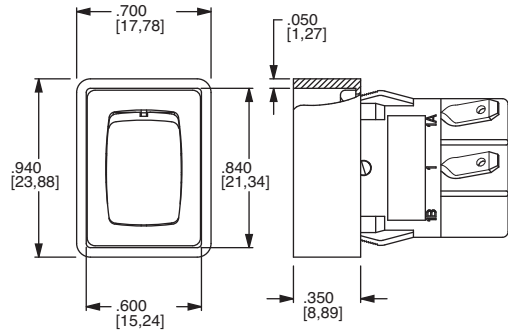

PANEL MOUNTING



'S2' & 'G2' housing styles

'B2' housing style

NOTE: Blank insert available for SP models only, see page H-76.

| PANEL THICKNESS | DIM 'A' 'S2' & 'G2' HOUSING STYLES | DIM 'A' 'G2' OPTION SP MODELS ONLY | DIM 'A' 'B2' HOUSING STYLES |
|----------------------------|------------------------------------|------------------------------------|-----------------------------|
| .030-.049 (0,76) (1,24) | .756 (19,20) | 0.764 (19,41) | 1.068 (27,13) |
| .049-.079 (1,24) (2,01) | .764 (19,41) | 0.780 (19,81) | 1.076 (27,33) |
| .079-.118 (2,01) (3,00) | .780 (19,81) | n/a | 1.092 (27,74) |

TERMINATIONS

05 QUICK CONNECT

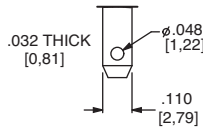

ACTUATOR MARKINGS

NONE NO MARKING

D ON-OFF

H 0 1

P 0 -

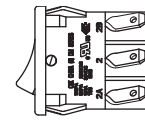
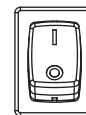

NOTE: Orientation of actuator markings and terminals.

'D & P' marking options: marking color white, standard for all actuator colors except white actuators. Black marking color standard for white actuators. Consult Customer Service Center for other available marking colors.

CONTACT MATERIAL

| OPTION CODE | CONTACT AND TERMINAL MATERIAL | RATINGS | | |
|-------------|-------------------------------|-------------|---|--|
| Q | SILVER ^{1,2} | DM21, DM22: | GP (general purpose) | 3 AMPS 125 VAC 50/60 Hz T85 10,000 cycles |
| | | | R (resistive) | 2 AMPS 250 VAC 50/60 Hz T85 10,000 cycles |
| | | DM61, DM62: | GP (general purpose) | 3 AMPS 30 VDC T85 10,000 cycles |
| | | | R (resistive) | 10 AMPS 125 VAC 50/60 Hz T85 10,000 cycles |
| | | | 5 AMPS 250 VAC 50/60 Hz T85 10,000 cycles | |
| | | | 10 AMPS 30 VDC T85 10,000 cycles | |

* Note: See Technical Data section of this catalog for RoHS compliant and compatible definitions and specifications.

¹ MOVABLE CONTACT: DM2X Models: Copper, silver plated.
DM6X Models: Coin silver, silver plated.

² STATIONARY CONTACTS & TERMINALS: Copper or brass, silver plated.

NOTE: Any models supplied with Q contact material are RoHS compliant.

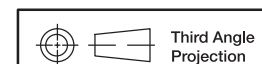

Dimensions are shown: Inches (mm)
Specifications and dimensions subject to change



2 aug 16

G-67

www.ck-components.com

Rocker



G

DM Series Miniature 2 Pole Power Rocker Switches

AVAILABLE HARDWARE

Insert

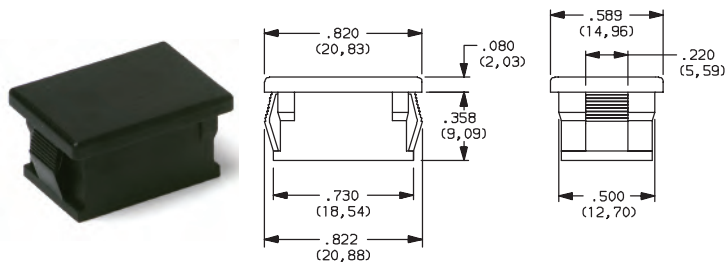

PART NO.
057190200

Material: Nylon 6/6
Finish: Matte

Recessed Actuator Guard



PART NO.
599D02000

Material: 6/6 Nylon
Finish: Matte

Actuator Guard

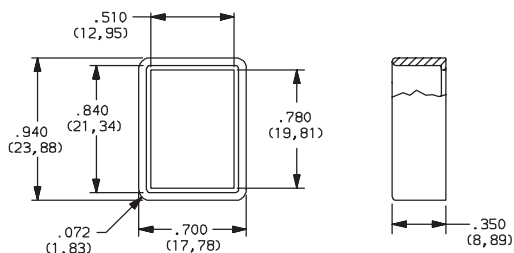

PART NO.
104C22000

Material: PBT thermoplastic
Finish: Matte

PART NO.

216C00000 IP65 SPLASH PROOF RUBBER BOOT

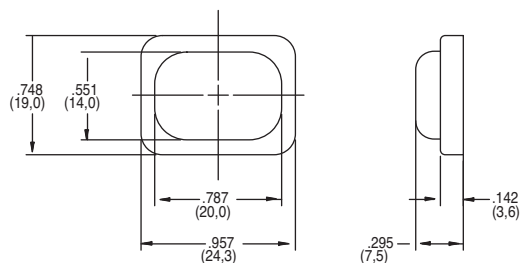

Rocker



G

C&K

2 aug 16



Third Angle
Projection

Dimensions are shown: Inches (mm)
Specifications and dimensions subject to change

DM Series Miniature Illuminated Power Rocker Switches



Features/Benefits

- 3 AMPS to 10 AMPS
- Illuminated LED
- Positive detent
- RoHS compliant

Typical Applications

- Instrumentation
- Industrial
- Office machines



Specifications

CONTACT RATING: DM14 and DM24 Models: 3 AMPS @ 125 V AC; 2 AMPS @ 250 V AC. DM54 and DM64 Models: 10 AMPS @ 125 V AC; 5 AMPS @ 250 V AC (UL).

ELECTRICAL LIFE: 10,000 make-and-break cycles at full load.

INSULATION RESISTANCE: $10^9 \Omega$ min.

DIELECTRIC STRENGTH: 1,000 Vrms min. @ sea level.

NOTE: Any models supplied with Q contact material are RoHS compliant.

NOTE: Specification and materials listed above are for standard switches. For information on specific and custom switches, consult Customer Service Center.

Materials

HOUSING: 6/6 nylon (UL94V-2), black.

ACTUATOR: 6/6 nylon (UL94V-2), black.

MOVABLE CONTACTS: DM14 and DM24 Models: Copper, silver plated. DM54 and DM64 Models: Coin silver, silver plated.

STATIONARY CONTACTS & TERMINALS: Copper or brass, silver plated.

LED TERMINALS: Brass, unplated.

CONTACT SPRING: Music wire or stainless steel.

OPERATING TEMPERATURE: -20°C to +65°C

Build-A-Switch

To order, simply select desired option from each category and place in the appropriate box. Available options are shown and described on pages G-70 and G-72. For additional options not shown in catalog, consult Customer Service Center.

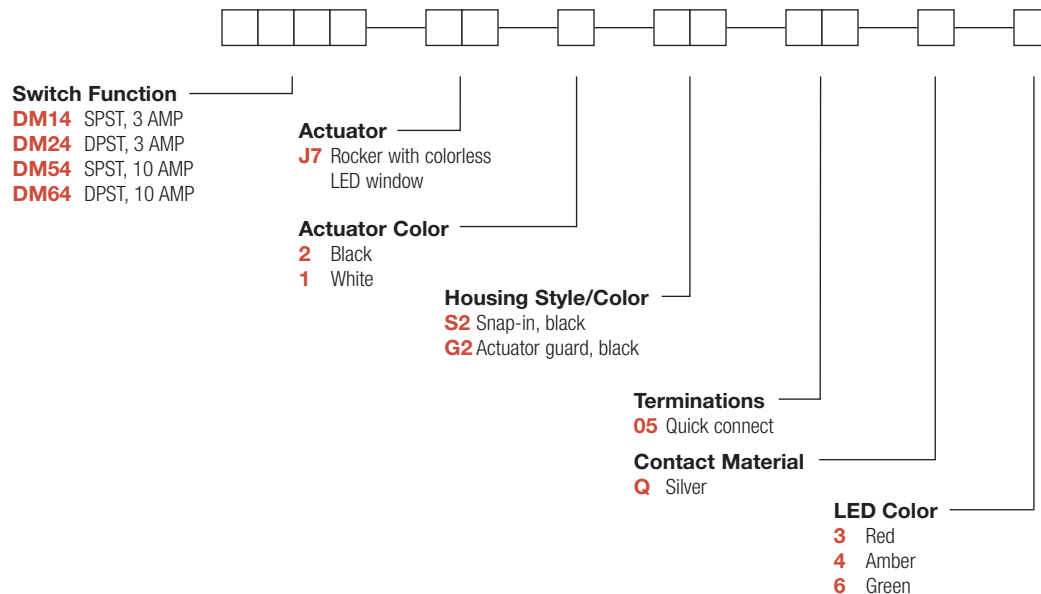

DM Series Miniature Illuminated Power Rocker Switches

SWITCH FUNCTION

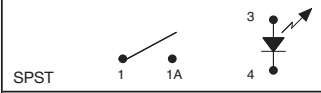
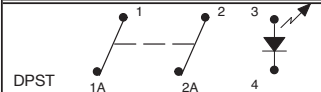
| NO. POLES | MODEL NO. | AMP RATING* | SWITCH FUNCTION | | CONNECTED TERMINALS | | SCHEMATIC |
|-----------|-------------|-------------|-----------------|--------|---------------------|--------|---|
| | | | POS. 1 | POS. 2 | POS. 1 | POS. 2 | |
| SP | DM14 | 3 | ON | OFF | 1-1A | OPEN |  |
| | DM54 | 10 | | | | | |
| DP | DM24 | 3 | ON | OFF | 1-1A, 2-2A | OPEN |  |
| | DM64 | 10 | | | | | |

DPDT

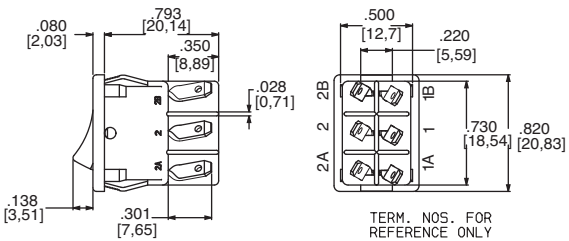

Actuator shown in pos. 1 - 'ON' position.
SPST MODELS (DM14 & DM54) OMIT TERMINALS 2 & 2A.

Part number shown: DM24J72S205Q3

* RATINGS: see page G-69.



ACTUATOR

J7 ROCKER WITH COLORLESS LED WINDOW

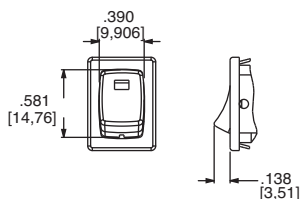

| OPTION CODE | ACTUATOR COLOR |
|-------------|----------------|
| 2 | BLACK |
| 1 | WHITE |

NOTE: Other colors available, consult Customer Service Center.

HOUSING STYLE/COLOR

S2 SNAP-IN, BLACK

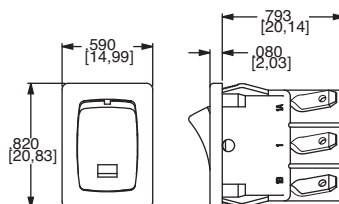

NOTE: Housing finish: matte. Other colors available, consult Customer Service Center.

Rocker



G

C&K

2 aug 16



Dimensions are shown: Inches (mm)
Specifications and dimensions subject to change

DM Series Miniature Illuminated Power Rocker Switches

HOUSING STYLE/COLOR

G2 ACTUATOR GUARD, BLACK

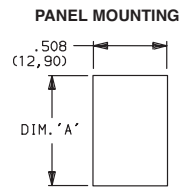
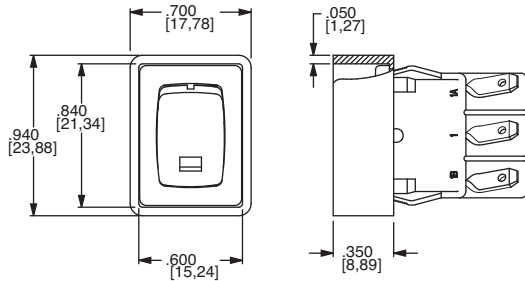

'S2' & 'G2' housing style

NOTE: Blank insert available for SP models only, see page H-80.

| PANEL THICKNESS | DIM 'A' 'S2' & 'G2' HOUSING STYLES | DIM 'A' with 'G2' option SP MODELS ONLY |
|----------------------------|------------------------------------|---|
| .030-.049 (0,76) (1,24) | 0.756 (19,20) | 0.764 (19,41) |
| .049-.079 (1,24) (2,01) | 0.764 (19,41) | 0.780 (19,81) |
| .079-.118 (2,01) (3,00) | .780 (19,81) | n/a |

TERMINATIONS

05 QUICK CONNECT

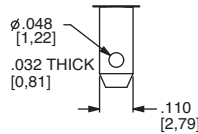

CONTACT MATERIAL

| OPTION CODE | CONTACT AND TERMINAL MATERIAL | RATINGS | |
|-------------|-------------------------------|---------|---|
| | | POWER | DM14 and DM24 Models: 3 AMPS @ 125 V AC; 2 AMPS @ 250 V AC. DM54 and DM64 Models: 10 AMPS @ 125 V AC; 5 AMPS @ 250 V AC. |

* Note: See Technical Data section of this catalog for RoHS compliant and compatible definitions and specifications.

¹ MOVABLE CONTACTS: DM14 and DM24 models: Copper, silver plated.
DM54 and DM64 models: Coin silver, silver plated.

² STATIONARY CONTACTS & TERMINALS: Copper or brass, silver plated.

NOTE: Any models supplied with Q contact material are RoHS compliant.



LED COLOR

| OPTION CODE | LED COLOR | FORWARD V_{FD} | CURRENT I_{LED} | REVERSE V_R | INTENSITY M_{CD} | RECOMMENDED RESISTOR @ VOLTAGE | | |
|-------------|-----------|------------------|-------------------|---------------|--------------------|--------------------------------|-----|------|
| | | | | | | 5V | 12V | 24V |
| 3 | Red | 2.1 | 10 | 4V | 1.6 typ. | 270 | 1K | 2.2K |
| 4 | Amber | 2.2 | 20 | 4V | 2.5 typ. | 150 | 510 | 1.2K |
| 6 | Green | 2.1 | 20 | 4V | 2.0 typ. | 150 | 510 | 1.2K |

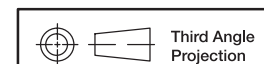

Third Angle Projection
Dimensions are shown: Inches (mm)
Specifications and dimensions subject to change



2 aug 16



DM Series Miniature Illuminated Power Rocker Switches

AVAILABLE HARDWARE

Blank Insert

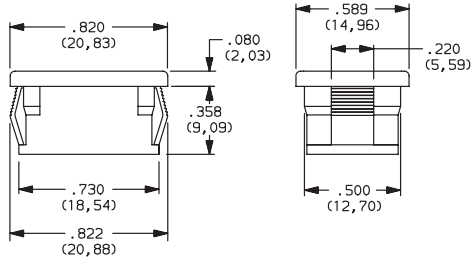

PART NO.
057190200

Material: Zinc nylon 6/6
Finish: Matte

Recessed Bracket



PART NO.
599D02000

Material: 6/6 Nylon
Finish: Matte

Actuator Guard

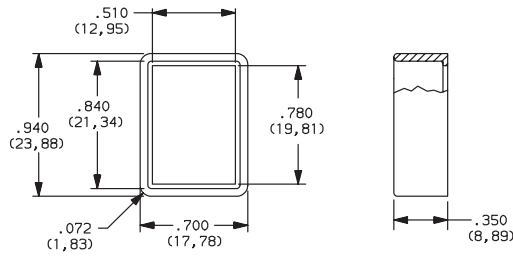

PART NO.
104C22000

Material: PBT thermoplastic
Finish: Matte

Rocker



C&K

2 aug 16

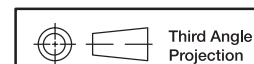

Third Angle
Projection

Dimensions are shown: Inches (mm)
Specifications and dimensions subject to change

DF Series Power Rocker Switches



Features/Benefits

- Power switching up to 16 AMPS
- Sub-panel and Front-panel mounting
- PC and quick connect terminals
- Multi-position and multi-pole function
- RoHS compliant

Typical Applications

- Computers
- Power supplies
- Appliances
- Fitness equipment
- Off-road vehicles



Specifications

CONTACT RATING: 16 AMPS @ 125, 250 V AC; 1/4 HP @ 125 V AC; 1/2 HP @ 250 V AC; 6 AMPS @ 48 V DC, 2 AMPS @ 60 V DC, 11 AMPS @ 30 V DC

ELECTRICAL LIFE: 10,000 make-and-break cycles at full load.

INSULATION RESISTANCE: $10^9 \Omega$ min.

DIELECTRIC STRENGTH: 1,000 Vrms min. @ sea level.

OPERATING TEMPERATURE: -20°C to +85°C

Materials

HOUSING & ACTUATOR: 6/6 nylon (UL 94V-2), black, finish: matte.

CONTACTS: Fine silver, silver plated.

TERMINALS: Copper, silver plated.

CONTACT SPRING: Music wire or stainless steel.

NOTE: Specifications and materials listed above are for standard switches. For information on specific and custom switches, consult Customer Service Center.

Build-A-Switch

To order, simply select desired option from each category and place in the appropriate box. Available options are shown and described on pages G-74 thru G-76. For additional options not shown in catalog, consult Customer Service Center.

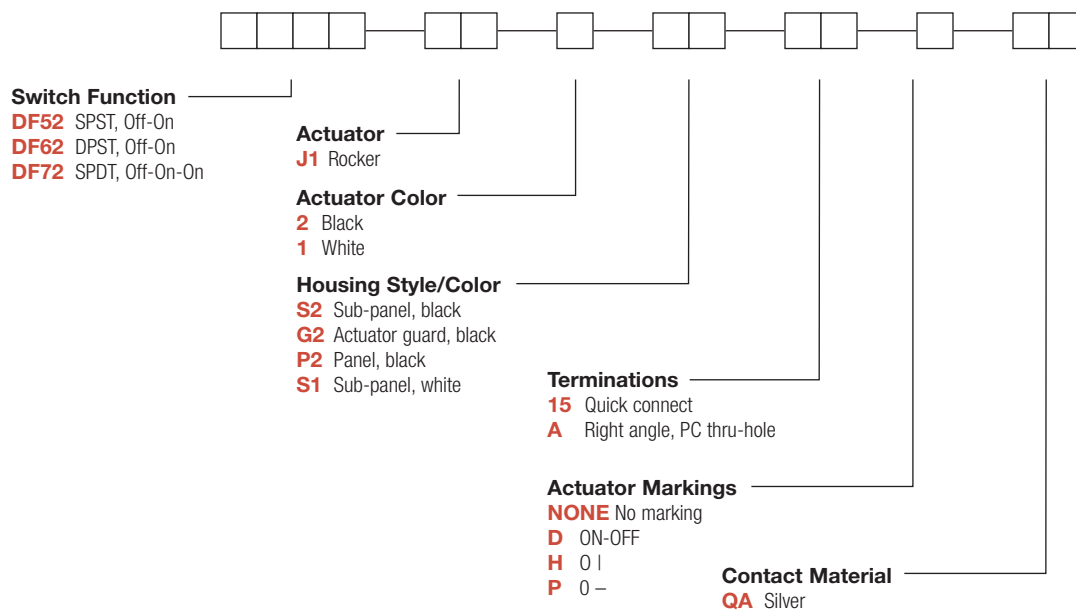

DF Series Power Rocker Switches

SWITCH FUNCTION

| NO. POLES | MODEL NO. | SWITCH FUNCTION | | CONNECTED TERMINALS | | SCHEMATIC |
|-----------|-------------|-----------------|--------|---------------------|------------|-----------|
| | | POS. 1 | POS. 2 | POS. 1 | POS. 2 | |
| SP | DF52 | OFF | ON | OPEN | 1-1A | SPST |
| DP | DF62 | OFF | ON | OPEN | 1-1A, 2-2A | DPST |

| NO. POLES | MODEL NO. | POS. 1 | POS. 2 | POS. 3 | POS. 1 | POS. 2 | POS. 3 | SCHEMATIC |
|-----------|-------------|--------|--------|--------|--------|----------|----------------------|-----------|
| | | | | | | | | |
| SP | DF72 | OFF | ON | ON | OPEN | 1 / 2-2A | 1 / 2-1A 1 / 2-2A | |

DPST

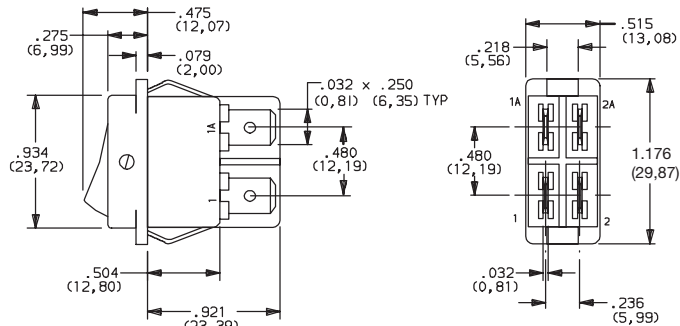

Part number shown: DF62J12S215QA

All models

ACTUATOR

J1 ROCKER

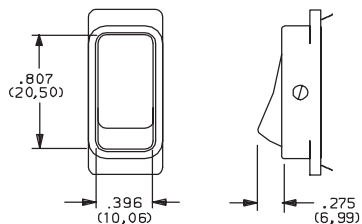

| OPTION CODE | ACTUATOR COLOR |
|-------------|----------------|
| 2 | BLACK |
| 1 | WHITE |

NOTE: Actuator finish: matte. Other colors available, consult Customer Service Center.

Rocker



G

C&K



Dimensions are shown: Inches (mm)
Specifications and dimensions subject to change

DF Series Power Rocker Switches

HOUSING STYLE/COLOR

S SUB-PANEL

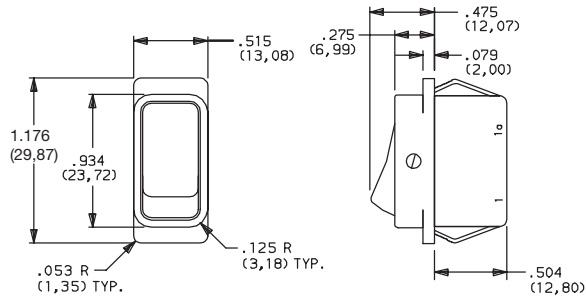

NOTE: DF52 & DF62 models only.

G2 ACTUATOR GUARD

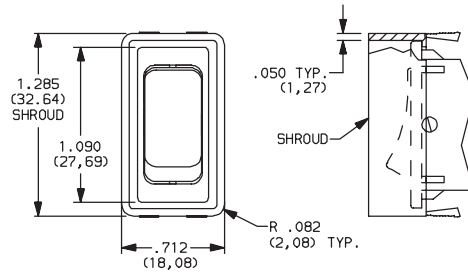

NOTE: Not available with 'A' termination. Available in black only.

P PANEL

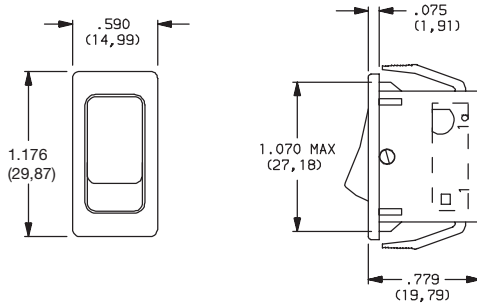

NOTE: Not available with 'A' termination. Available in black only.

| OPTION CODE | HOUSING COLOR |
|-------------|---------------|
| 2 | (STD.) BLACK |
| 1 | WHITE |

NOTE: Housing finish: matte. Other colors available, consult Customer Service Center.

PANEL MOUNTING

| PANEL THICKNESS | DIM 'A' |
|-------------------------|---------------|
| .029-.048 (0,74) (1,22) | 1.021 (25,93) |
| .048-.078 (1,22) (1,98) | 1.029 (26,14) |
| .078-.117 (1,98) (2,97) | 1.045 (26,54) |
| .075-.140 (1,91) (3,56) | 1.075 (27,31) |

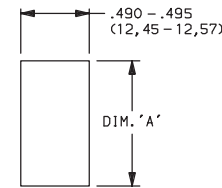

DF52 & DF62 Models with 'S' housing style

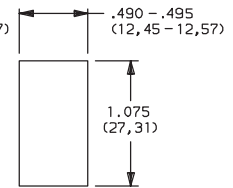

DF52, DF62 & DF72 Models with 'P2' & 'G2' housing style

TERMINATIONS

15 QUICK CONNECT

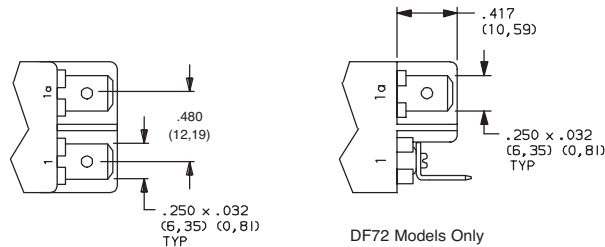

A RIGHT ANGLE, PC THRU-HOLE

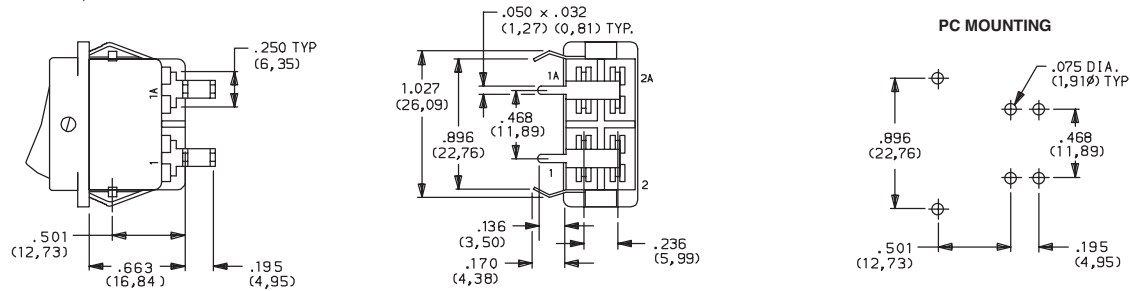

Actuator shown in Pos. 1

NOTE: DF52 and DF62 Models Only

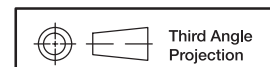

Third Angle Projection

Dimensions are shown: Inches (mm)
Specifications and dimensions subject to change



DF Series Power Rocker Switches

ACTUATOR MARKINGS

NONE NO MARKING

D ON-OFF

H O |

P O -

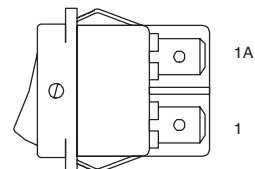

NOTE: Orientation of actuator markings and terminals.

'D, H, & P' marking options: marking color white, standard for all actuator colors except white. Marking color black, standard for white actuators. Consult Customer Service Center for other available marking colors.

CONTACT MATERIAL

| OPTION CODE | CONTACT AND TERMINAL MATERIAL | RATINGS | |
|-------------|-------------------------------|---------|---|
| | | POWER | |
| QA | SILVER 1,2 | | 16 AMPS @ 125, 250 V AC; 1/4 HP @ 125 V AC; 1/2 HP @ 250 V AC; 6 AMPS @ 48 V DC (UL), 2 AMPS @ 60 V DC, 11 AMPS @ 30 V DC |
| | | | 16 AMPS @ 125, 250 V AC; 1/4 HP @ 125 V AC; 1/2 HP @ 250 V AC (UL) |

* Note: See Technical Data section of this catalog for RoHS compliant and compatible definitions and specifications.

1 CONTACTS: Fine silver, silver plated.

All models 

2 TERMINALS: Copper, silver plated.

AVAILABLE HARDWARE

Actuator Guard

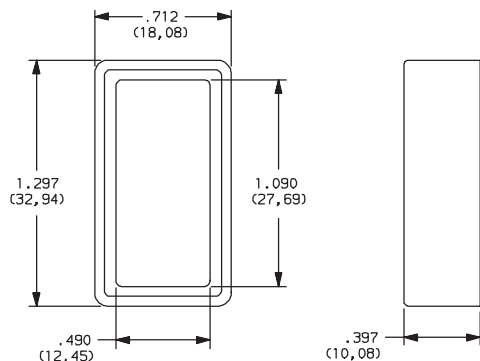

PART NO.

285B02000

Material: Nylon 6/6
Finish: Matte

Rocker



G

C&K



Third Angle Projection

Dimensions are shown: Inches (mm)
Specifications and dimensions subject to change

CR Series Round Single Pole Specialty Rocker Switches

Features/Benefits

- Round actuator and body
- Nice styling
- Multiple illuminated versions available
- IP65 splash proof rubber boot option

Typical Applications

- Appliances, small and large
- Office equipment
- Computers and peripherals
- Audio/Video equipment
- RoHS compliant



UL US UL 61058-1

Specifications

CONTACT RATING:

16 AMPS @ 125 VAC, 10 AMPS @ 250 VAC.

16 AMPS @ 125 VAC, 10 AMPS @ 250 VAC.

ELECTRICAL LIFE: 10,000 make and break cycles at full load.

INSULATION RESISTANCE: $10^8 \Omega$ min.

DIELECTRIC STRENGTH: 1,500 VRMS @ sea level.

OPERATING TEMPERATURE: -20°C to + 85°C

Materials

HOUSING AND ACTUATOR: 6/6 nylon (UL94V-2), matte finish.

ILLUMINATED ACTUATOR: Polycarbonate, matte finish.

CENTER CONTACTS: Silver plated, copper alloy.

END CONTACTS: Silver plated AgSnO₂InO₃.

ALL TERMINALS: Silver plated, copper alloy.

NOTE: Specifications and materials listed above are for switches with standard options. For information on specific and custom switches, consult Customer Service Center.

Build-A-Switch

To order, simply select desired option from each category and place in the appropriate box. Available options are shown and described on pages G-78 through G-80. For additional options not shown in catalog, consult Customer Service Center.

| | | |
|---|--|--|
| <p>Switch Function</p> <p>CR101 SPDT On-None-On</p> <p>CR102 SPST On-None-Off</p> <p>Actuator</p> <p>J1 Rocker</p> <p>J2* Two-tone rocker</p> <p>J3 Illuminated rocker</p> <p>J4** Circle, illuminated rocker</p> <p>J5 Oval, illuminated rocker</p> <p>JN Paddle, rocker</p> <p>JP Paddle, illuminated rocker</p> | <p>Actuator Color</p> <p>2 Black</p> <p>1 White</p> <p>3 Red</p> <p>R Red, illuminated</p> <p>A Amber, illuminated</p> <p>G Green, illuminated</p> <p>Mounting Style/Color</p> <p>S2 Snap-in, black</p> <p>S1 Snap-in, white</p> | <p>Termination</p> <p>15 .187" quick connect</p> <p>Contact Rating</p> <p>QF Silver</p> <p>Lamp Rating</p> <p>(NONE) No lamp</p> <p>6 LED</p> <p>7 125 VAC neon</p> <p>8 250 VAC neon</p> |
|---|--|--|

* Refer to table on page G-79 for actuator options.



Dimensions are shown: Inches (mm)
Specifications and dimensions subject to change



CR Series Round Single Pole Specialty Rocker Switches

SWITCH FUNCTION

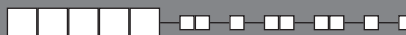

| NO. POLES | MODEL NO. | SWITCH FUNCTION | | | CONNECTED TERMINALS | | | SCHEMATIC |
|-----------|--------------|-----------------|--------|--------|---------------------|--------|--------|---|
| | | Pos. 1 | Pos. 2 | Pos. 3 | Pos. 1 | Pos. 2 | Pos. 3 | |
| | | | | | | | | |
| | CR101 | ON | NONE | ON | 2-3 | | 2-1 | |
| SP | CR102 | ON | NONE | OFF | | N/A | | OR For 7 & 8 Illuminated Versions |

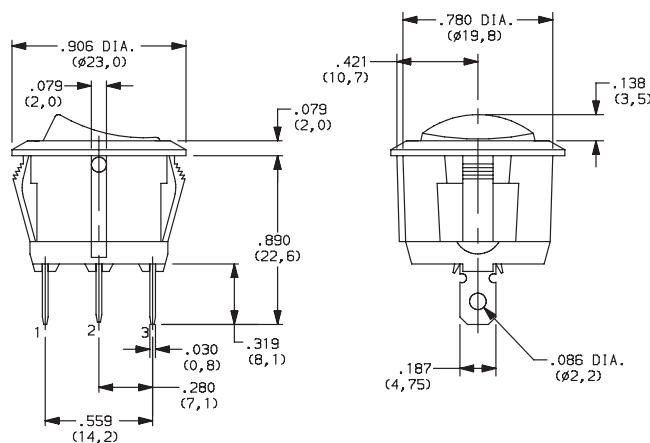

ACTUATOR



- J1** ROCKER
- J3** ILLUMINATED ROCKER

- J2** TWO-TONE ROCKER

Rocker

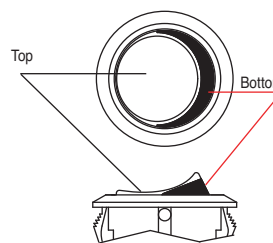
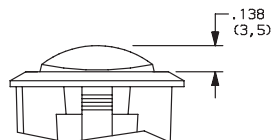
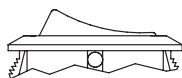
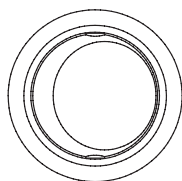

NOTE: J3 actuator available with the combination of 7 & 8 lamp ratings and CR102 switch function only.



G

C&K



Third Angle Projection
Dimensions are shown: Inches (mm)
Specifications and dimensions subject to change

CR Series Round Single Pole Specialty Rocker Switches

ACTUATOR

J4 CIRCLE, ILLUMINATED ROCKER

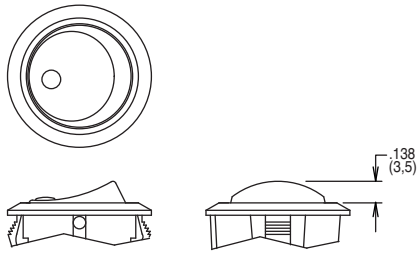

NOTE: Available with the combination of CR102 switch function and 7 & 8 lamp ratings only.

J5 OVAL, ILLUMINATED ROCKER

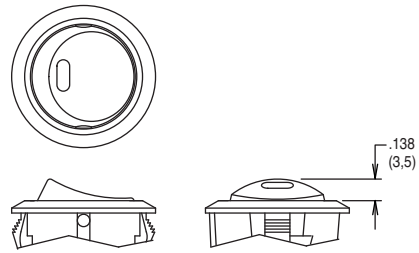

NOTE: Available with the combination of CR102 switch function and 6 lamp rating only.

JN PADDLE, ROCKER

JP PADDLE, ILLUMINATED ROCKER

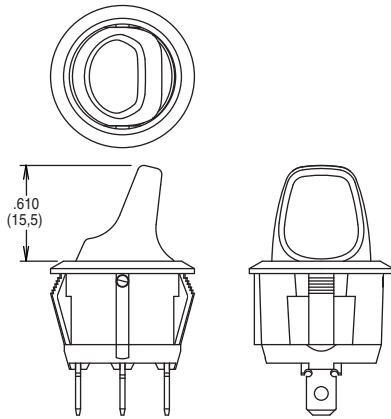

NOTE: JP actuator available with the combination of CR102 switch function and 7 & 8 lamp ratings only.

ACTUATOR COLOR

| ACTUATOR | OPTION CODE | ACTUATOR COLOR |
|--------------------------------|-------------|--------------------|
| J1 | 2 | BLACK |
| | 1 | WHITE |
| | 3 | RED |
| J3, J4 J5, JP | R | RED, ILLUMINATED |
| | A | AMBER, ILLUMINATED |
| | G | GREEN, ILLUMINATED |

| ACTUATOR | OPTION CODE | ACTUATOR COLOR | |
|-----------|-------------|----------------|--------|
| | | TOP | BOTTOM |
| J2 | 1 | WHITE | RED |
| | 2 | WHITE | BLACK |
| | 3 | RED | WHITE |
| | 4 | BLACK | WHITE |
| | 5 | BLACK | RED |

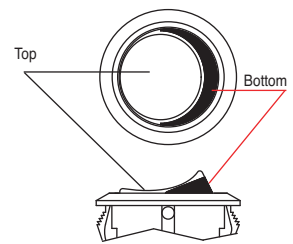

J2 actuator only

MOUNTING STYLE/COLOR

S2 SNAP-IN, BLACK

S1 SNAP-IN, WHITE

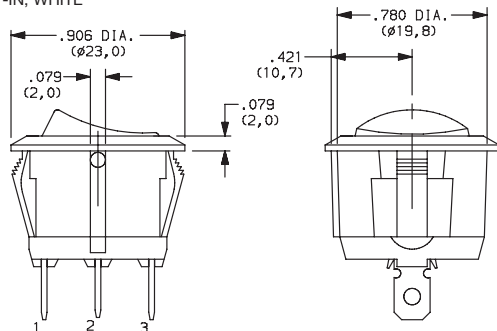

PANEL MOUNTING

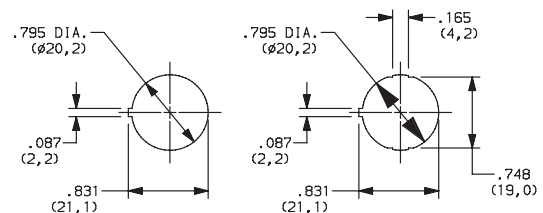

Panel thickness:
2.0 - 3.0 mm

Panel thickness:
0.7 - 3.0 mm



Third Angle Projection

Dimensions are shown: Inches (mm)
Specifications and dimensions subject to change

C&K



CR Series Round Single Pole Specialty Rocker Switches

TERMINATION



15 .187" QUICK CONNECT

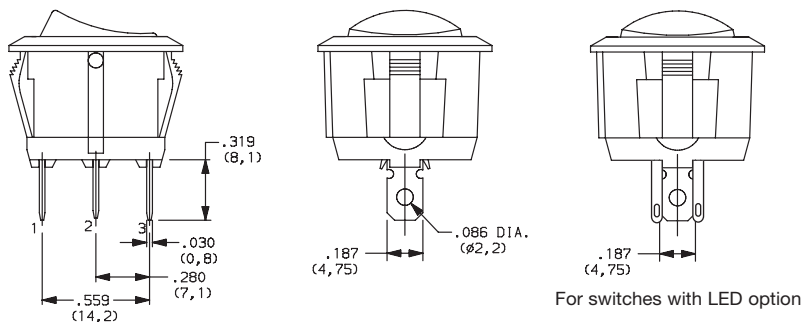

CONTACT MATERIAL



| OPTION CODE | CONTACT AND TERMINAL MATERIAL | RATINGS | |
|-------------|-------------------------------|---------|--|
| QF | SILVER | POWER | 16 AMPS @ 125 VAC; 10 AMPS @ 250 VAC  |

* Note: See Technical Data section of this catalog for RoHS compliant and compatible definitions and specifications.

LAMP RATING



(NONE) NO LAMP

6 LED RATING @ 10 mA $V_f=1.85V$

7 125 VAC 33k Ω NEON

8 250 VAC 150k Ω NEON

ACCESSORIES

377C00000 IP65 SPLASH PROOF RUBBER BOOT

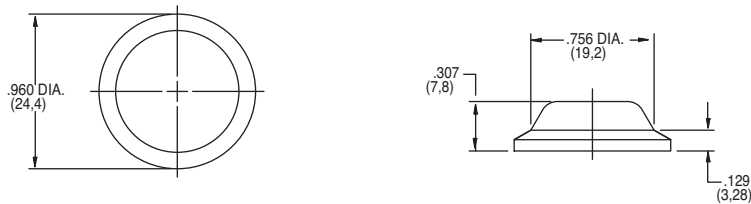

Rocker

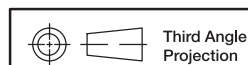

Dimensions are shown: Inches (mm)
Specifications and dimensions subject to change

SW Series Rocker Switches

Features/Benefits

- Various designs up to 16 amps
- Heavy duty and extended life cycles
- SPST, SPDT and DPST options
- Different symbols available

Typical Applications

- Household appliances
- Industrial equipment
- Audio & visual equipment
- Telecommunication
- Office equipment



Specifications

CONTACT RATING: 6.5 Amps @ 125 VAC
 ELECTRICAL LIFE: 6,000 cycles at full load.
 INITIAL CONTACT RESISTANCE: 100m Ω min.
 INSULATION RESISTANCE: 100M Ω min.
 DIELECTRIC STRENGTH: 1,500 VAC (50-60 Hz)
 OPERATING FORCE: ON_OFF: 250 \pm 100 gf
 OFF_ON: 700 \pm 250 gf
 PACKAGING: 300 pieces per bag (5 trays)
 2,400 pieces per box

Materials

HOUSING: PA (UL 94V-2).
 KNOB: PA (UL 94V-2).
 CONTACTS: Silver plated.

NOTE: Specifications and materials listed above are for switches with standard options. For information on specific and custom switches, consult Customer Service Center.

Environmental

OPERATING TEMPERATURE: 0°C to 65°C

| PART NUMBER | HOUSING COLOR |
|------------------|---------------|
| SW-13A65N-A01 | White |
| SW-13A65N-A01 BK | Black |

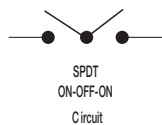
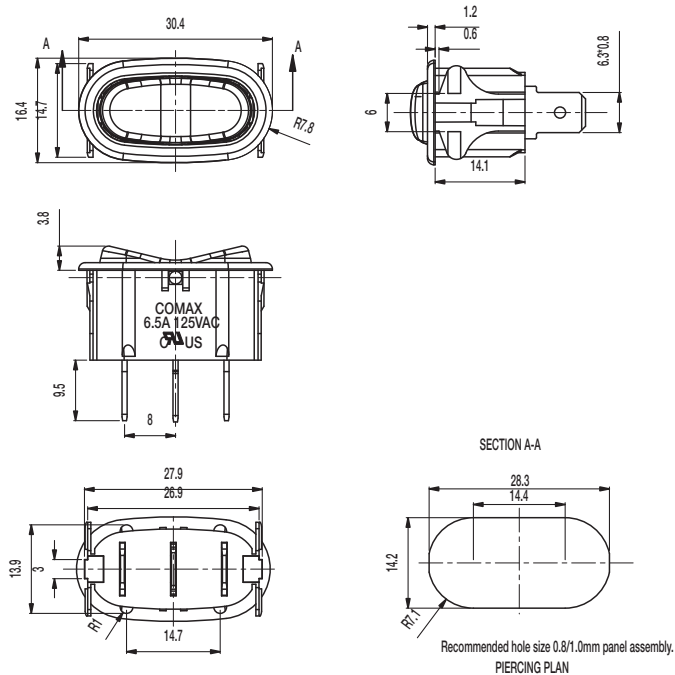

DIP

Product Selection Guide



H

DIP

| DIP | | | | | | | | | | | |
|-----------------------------------|---|-------------------------------|---|--|---|---|-------------------------------|---|---|---|--|
| Series | TDP | TDA | SDA | SD | BD | BPA | TDD | SPA | RTE | CD | CRD |
| Switch Type | Half-pitch .050" Side actuated | Half-pitch .050" | Low Profile | Low Profile | Standard Profile | Side Actuated | Jumper Switch | Single In-line Package | Rotary & Coded | 8 mm Coded Rotary | 10 mm Coded Rotary |
| No. of Positions | 2-10 (even only) | 1 & 2-10 (even only) | 1-12 (except 11) | 2-12 (except 11) | 1-12 (except 11) | 1-12 (except 11) | 1 | 2-10 (even only) | 4 10,16 | 8, 10 & 16 | 10 & 16 |
| Contact Style | SPST | SPST | SPST | SPST | SPST | SPST | SPDT | SPST | Coded | Coded | Coded |
| Profile off PCB | .173 (4,4) | .087 (2,2) | .189 (4,80) Thru-hole .177 (4,5) SMT | .168 (4,27) Thru-hole .160 (4,06) SMT | .297 (7,55) Vertical .380 (9,65) Rt. Angle | .287 (7,3) Thru-hole .277 (7,04) SMT | .090 (2,3) | .244 (6,2) Vertical .169 (4,3) Rt. Angle | .167 (4,25) Thru-hole .335 (8,5) Rt. angle | .168 (4,27) Thru-hole .340 (8,6) Rt. angle | .272 (6,9) Vertical .414 (10,5) Rt. angle |
| Process Sealed | washable with tape seal | washable with tape seal | washable (tape not required) | washable with tape seal | washable (tape not required) | washable (tape not required) | washable with tape seal | washable (tape not required) | NA | washable (tape not required) | washable (tape not required) |
| Extended Actuator | • | | • | • | • | • | | • | • | | • |
| Flush Actuator | • | • | • | • | | | • | • | • | • | • |
| Thru-hole | | | • | • | • | • | | • | • | • | • |
| Vertical | | • | • | • | • | | • | • | • | • | • |
| Right Angle | • | | | | • | • | | • | • | • | • |
| Surface Mount | • | • | • | • | | • | • | • | • | • | • |
| Tape & Reel (SMT only) | • | • | • | • | | • | • | • | • | • | • |
| Maximum Current | 100mA | 100mA | 100mA | 100mA | 100mA | 100mA | 100mA | 10mA | 100mA | 0.4VA | 0.4VA |
| Retention Feature | | | | | | | | • | • | • C option | |
| Page No. | H-3 | H-6 | H-9 | H-13 | H-16 | H-18 | H-21 | H-23 | H-25 | H-31 | H-35 |

TDP Series Ultra-miniature Surface Mount Half-pitch Side-Actuated DIP Switches



Features/Benefits

- World's first ultra-miniature SMT half-pitch side-actuated DIP
- Side actuation allows visual indication of on/off position in horizontal applications
- Process sealed for surface mount soldering and washable processing
- RoHS compliant
- Lead free

Typical Applications

- Hand-held electronic devices
- Portable computer and electronic devices
- Instrumentation and controls



Specifications

SWITCH FUNCTION: SPST — 2, 4, 6, 8, 10 positions.

CONTACT RATING:

24 V DC, 25 mA (switching).

50 V DC, 100 mA (steady state).

MECHANICAL AND ELECTRICAL LIFE: 1,000 cycles.

CONTACT RESISTANCE: 100 mΩ max.

INSULATION RESISTANCE: 100 MΩ @ 100 V DC min.

DIELECTRIC STRENGTH: 300 V AC min.

STORAGE TEMPERATURE: -40°C to 85°C.

OPERATING TEMPERATURE: -40°C to 85°C.

OPERATING FORCE: 4,9N max.

SOLDERABILITY: Per MIL-STD-202F method 208D, or

EIA RS-186E method 9 (1 hour steam aging).

PACKAGING: Switches supplied in rigid dispensing tubes in full tube quantities only, this may affect order quantity. Tape and reel packaging also available.

Materials

CASE & COVER: glass filled PPS (UL94V-0).

ACTUATOR: PA6T (UL94V-0).

CONTACTS: Copper alloy with gold plate over nickel plate.

TERMINALS: Copper alloy, with gold over nickel plate.

All terminals are insert molded.

TAPE SEAL: Polyimide.

Note: Specifications and materials listed above are for switches with standard options. For information on specific and custom switches, consult Customer Service Center.

How To Order

The Build-A Switch concept allows you to mix and match options to create the switch you need. Below is a complete listing of options shown in catalog. To order, simply select desired option from each category and place in the appropriate box.

All switches supplied in "OFF" position.

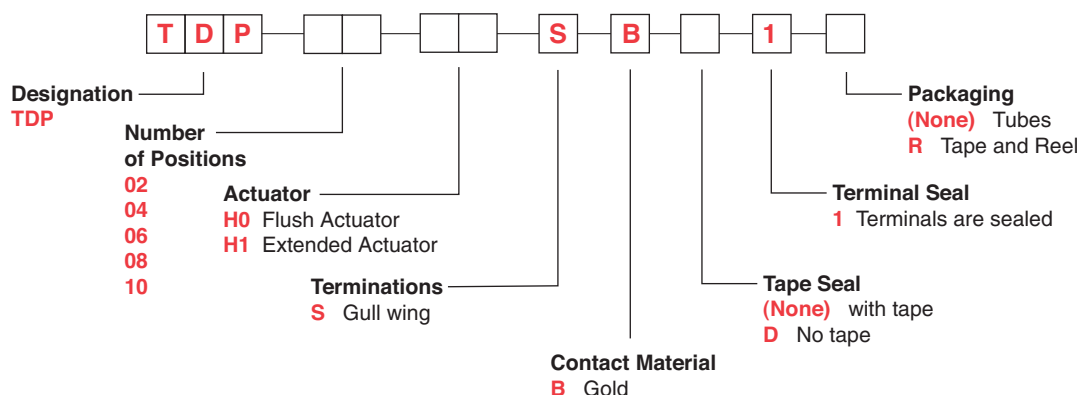

Note: Tape seal is not available with H1 Extended Actuators.

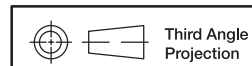

Dimensions are shown: Inch (mm)
Specifications and dimensions subject to change



TDP Series Ultra-miniature Surface Mount Half-pitch Side-Actuated DIP Switches

Flush Actuator-No Top Tape,
Surface Mount Terminals

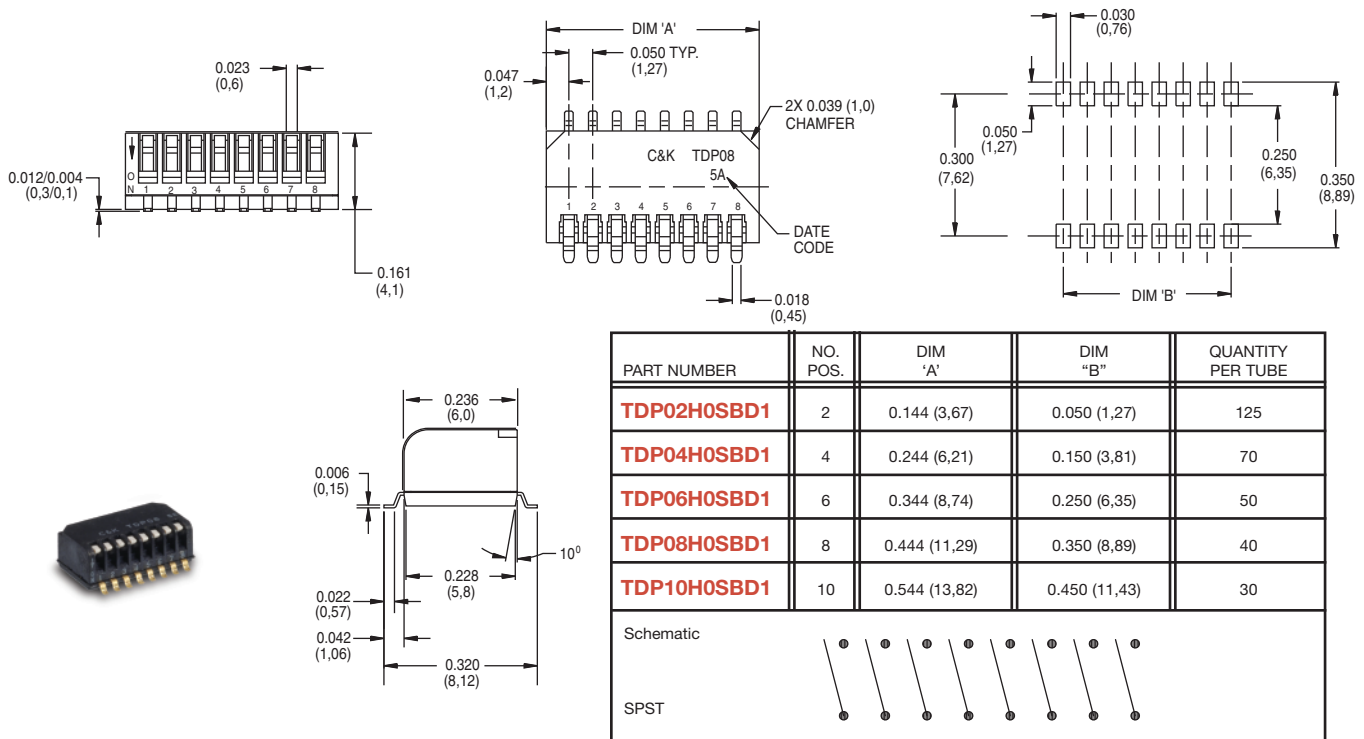

Flush Actuator-with Top Tape,
Surface Mount Terminals

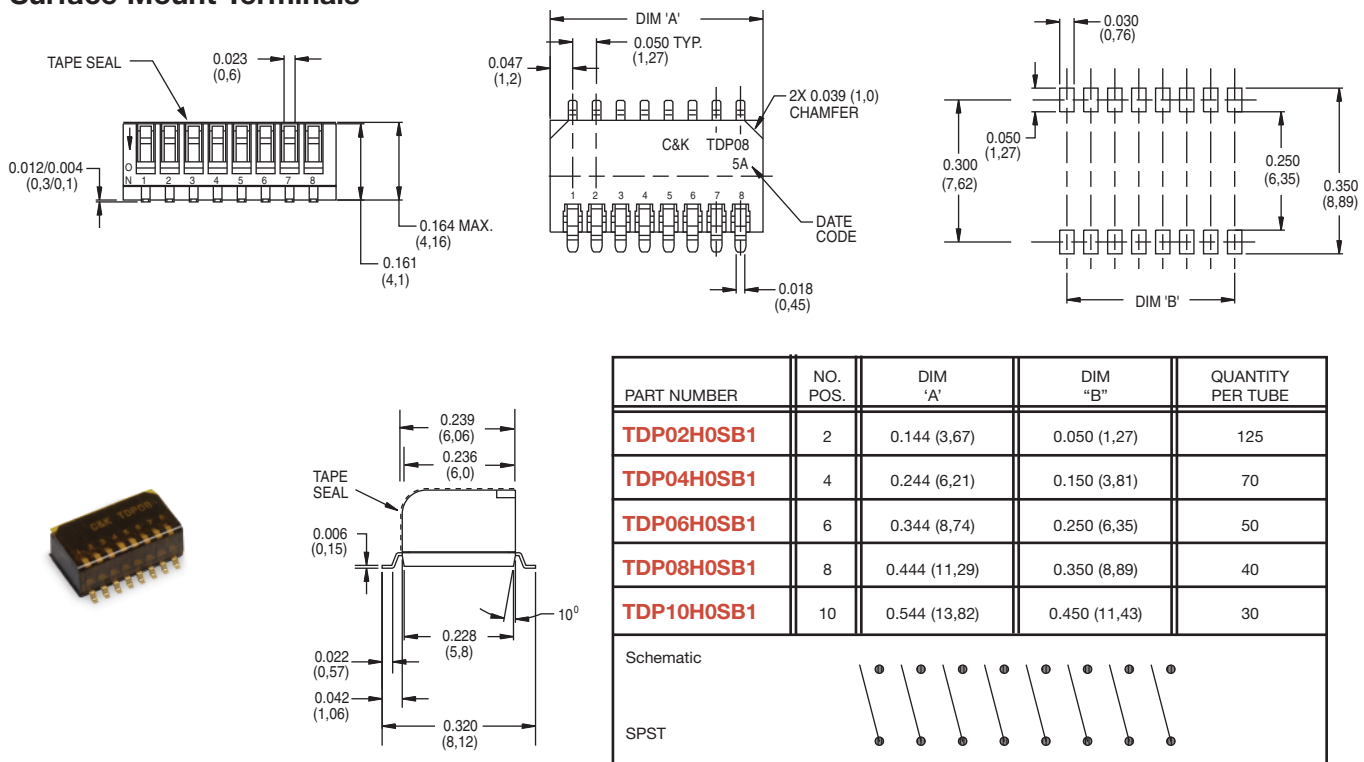

Dimensions are shown: Inch (mm)
Specifications and dimensions subject to change



TDP Series Ultra-miniature Surface Mount Half-pitch Side-Actuated DIP Switches



H
DIP

Extended Actuator-No Top Tape, Surface Mount Terminals

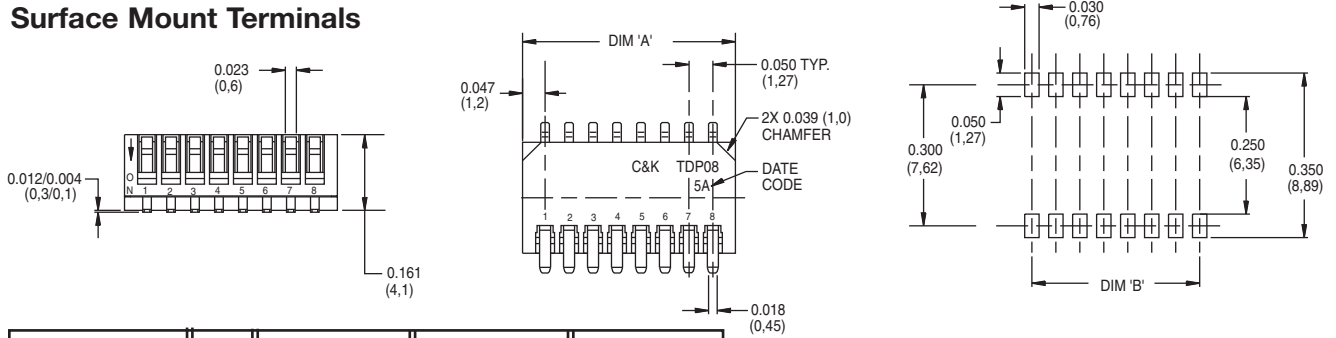

| PART NUMBER | NO. POS. | DIM 'A' | DIM "B" | QUANTITY PER TUBE |
|--------------------|----------|---------------|---------------|-------------------|
| TDP02H1SBD1 | 2 | 0.144 (3,67) | 0.050 (1,27) | 125 |
| TDP04H1SBD1 | 4 | 0.244 (6,21) | 0.150 (3,81) | 70 |
| TDP06H1SBD1 | 6 | 0.344 (8,74) | 0.250 (6,35) | 50 |
| TDP08H1SBD1 | 8 | 0.444 (11,29) | 0.350 (8,89) | 40 |
| TDP10H1SBD1 | 10 | 0.544 (13,82) | 0.450 (11,43) | 30 |

Schematic

SPST

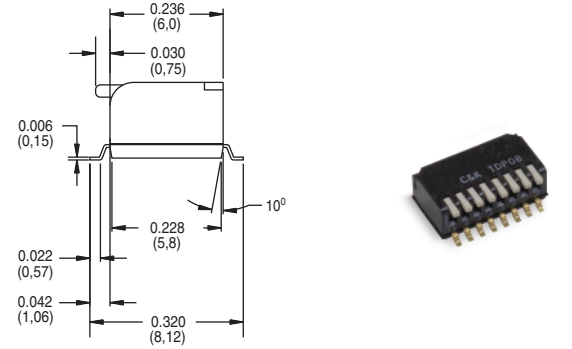

Tube Packaging

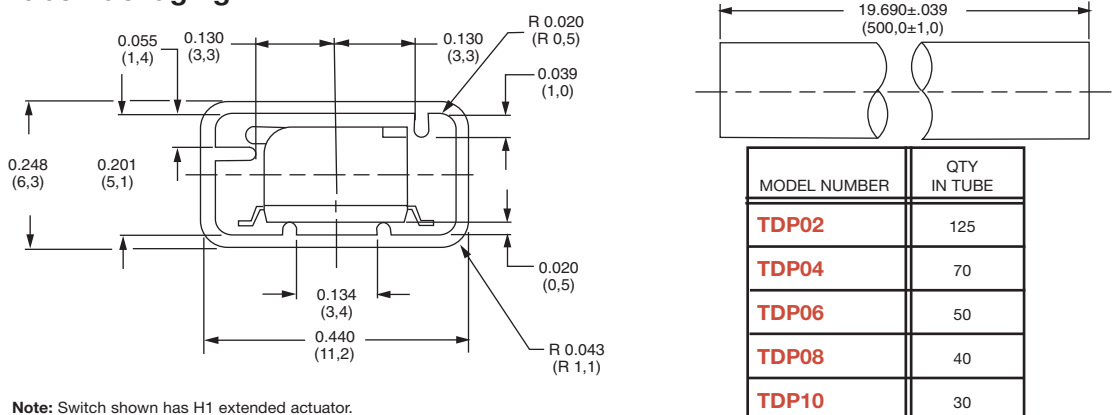

Note: Switch shown has H1 extended actuator.

Tape and Reel Packaging

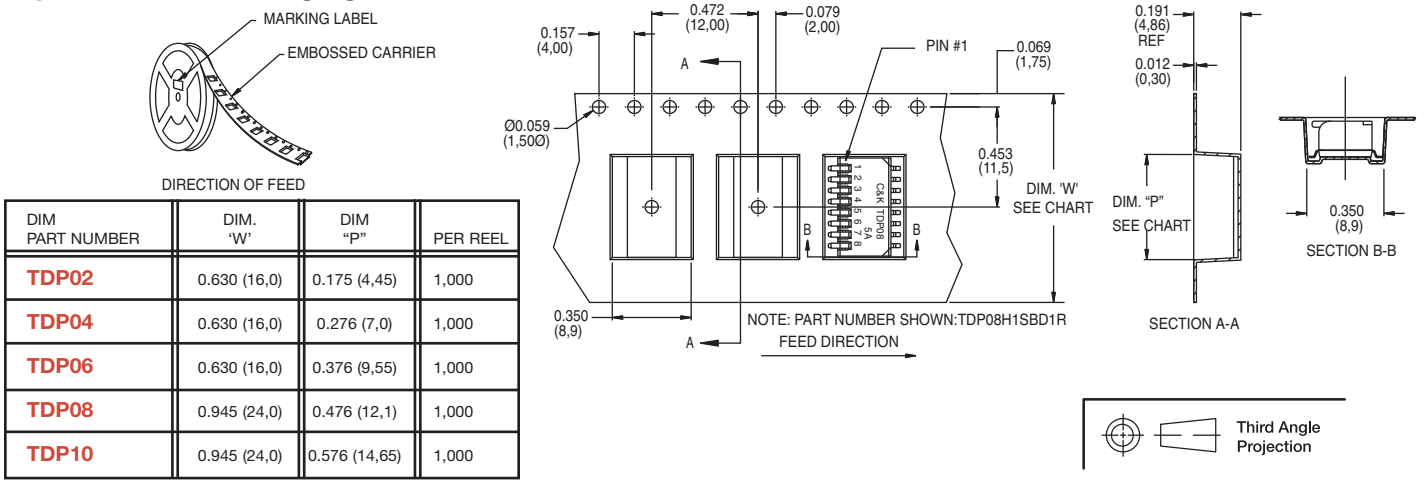

Dimensions are shown: Inch (mm)
Specifications and dimensions subject to change

TDA Series

Ultra-miniature Surface Mount Half-pitch DIP Switches



H

DIP

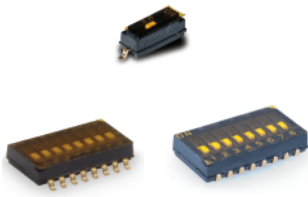

Features/Benefits

- Bifurcated contact for increased electrical reliability
- Process sealed for surface mount soldering and washable processing
- RoHS compliant

Typical Applications

- Hand-held electronic devices
- Portable computer and electronic devices
- Instrumentation and controls

Specifications

SWITCH FUNCTION: SPST – 1, 2, 4, 6, 8 & 10 positions.
 CONTACT RATING:
 24 V DC, 25 mA (switching).
 50 V DC, 100 mA (steady state).
 MECHANICAL AND ELECTRICAL LIFE: 1,000 cycles.
 CONTACT RESISTANCE: 100 mΩ max.
 INSULATION RESISTANCE: 100 MΩ @ 100 V DC min.
 DIELECTRIC STRENGTH: 300 V AC min.
 STORAGE TEMPERATURE: -40°C to 85°C.
 OPERATING TEMPERATURE: -40°C to 85°C.
 OPERATING FORCE: 4.9N max.
 SOLDERABILITY: Per MIL-STD-202F method 208D, or EIA RS-186E method 9 (1 hour steam aging).

PACKAGING: Switches supplied in rigid dispensing tubes in full tube quantities only, this may affect order quantity. Numbers of switches per tube varies with model. Tape and reel packaging quantity varies with model.

Materials

CASE & COVER: PPS (UL94V-0)
 ACTUATOR: LCP (UL94V-0).
 CONTACTS: Copper alloy, with gold plate over nickel plate.
 TERMINALS: Copper alloy, with gold flash over nickel plate.
 All terminals are insert molded.
 TAPE SEAL: Polyimide.

Note: Specifications and materials listed above are for switches with standard options. For information on specific and custom switches, consult Customer Service Center.

Note: All switches supplied in "OFF" position.

How To Order

The Build-A Switch concept allows you to mix and match options to create the switch you need. Below is a complete listing of options shown in catalog. To order, simply select desired option from each category and place in the appropriate box.

All switches supplied in "OFF" position.

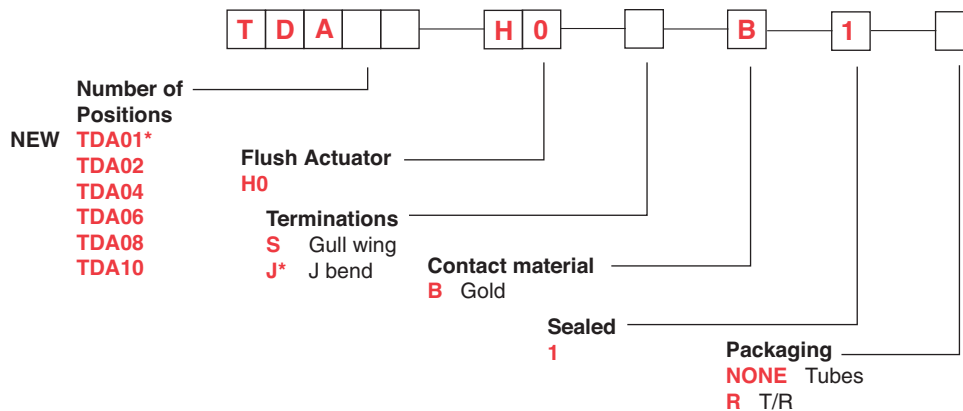

* TDA01H0JB1R is not available, TDA01 only offered in tape & reel



Dimensions are shown: mm
 Specifications and dimensions subject to change



TDA Series Ultra-miniature Surface Mount Half-pitch DIP Switches

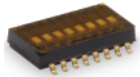

TDA08H0SB1

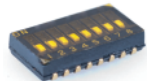
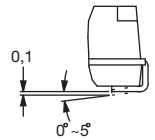
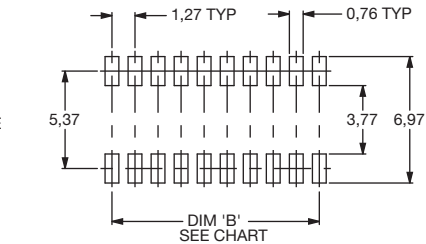
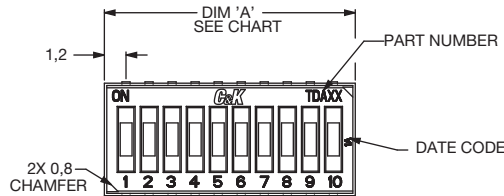
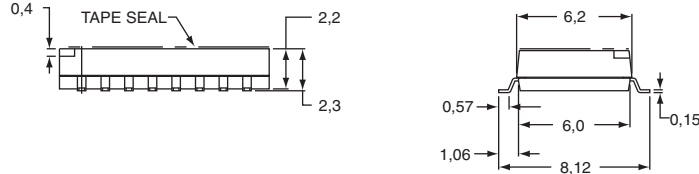
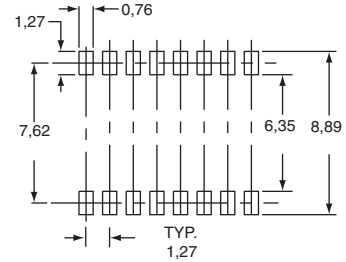
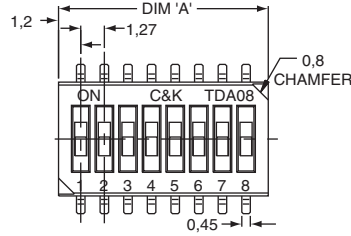

TDA10H0JB1

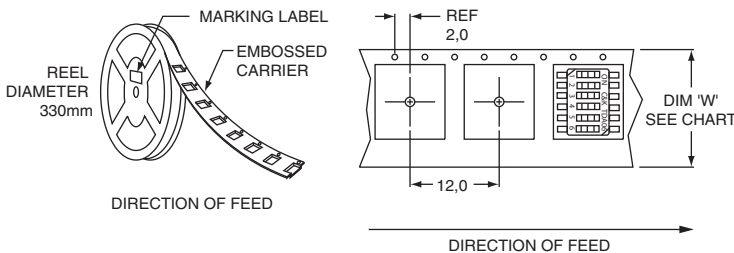
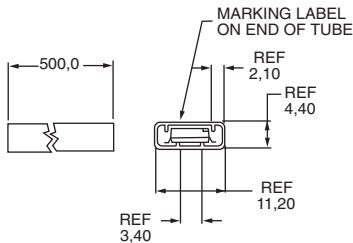
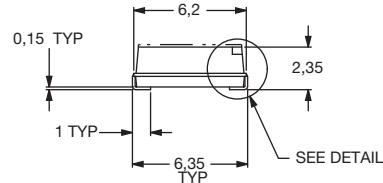
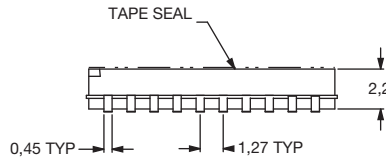

Tube Package

| ROHS PART NUMBER | NO. POS. | DIM. 'A' | DIM. 'B' | QUANTITY PER TUBE |
|------------------|----------|----------|----------|-------------------|
| TDA01H0SB1 | 1 | 2,40 | NA | NA |
| TDA02H0_B1 | 2 | 3,67 | 1,27 | 125 |
| TDA04H0_B1 | 4 | 6,21 | 3,81 | 70 |
| TDA06H0_B1 | 6 | 8,75 | 6,35 | 50 |
| TDA08H0_B1 | 8 | 11,29 | 8,89 | 40 |
| TDA10H0_B1 | 10 | 13,83 | 11,43 | 30 |

Schematic

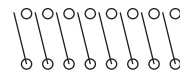

SPST

Tape & Reel Package

| ROHS PART NUMBER | NO. POS. | DIM. 'W' | QUANTITY PER REEL |
|------------------|----------|----------|-------------------|
| TDA01H0SB1R* | 1 | 16,0 | 2500 |
| TDA02H0_B1R | 2 | 16,0 | 2000 |
| TDA04H0_B1R | 4 | 16,0 | 2000 |
| TDA06H0_B1R | 6 | 16,0 | 2000 |
| TDA08H0_B1R | 8 | 24,0 | 2000 |
| TDA10H0_B1R | 10 | 24,0 | 2000 |

* see next page for TDA01 tape & reel drawing



Dimensions are shown: mm
Specifications and dimensions subject to change



TDA Series Ultra-miniature Surface Mount Half-pitch DIP Switches



DIP

DIP



TDA01H0SB1R

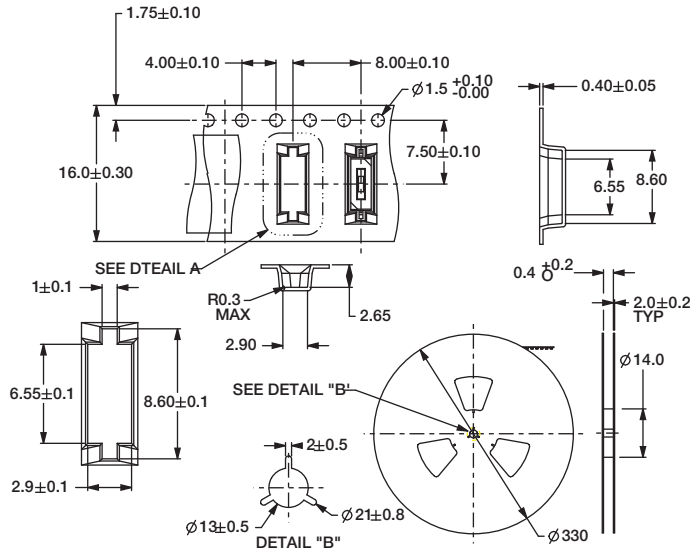

Dimensions are shown: Inch (mm)
Specifications and dimensions subject to change

SDA Series Low Profile DIP Switches



H

DIP

Features/Benefits

- Low profile design saves space
- Thru-hole and surface mount models
- Tape and reel packaging available
- RoHS compliant

Typical Applications

- Address switch for industrial controls
- Logic switching for computers and peripherals
- Function controlling for numerous applications

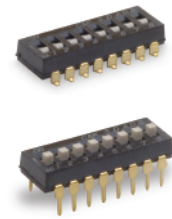

Specifications

CONTACT RATING: 25 mA @ 24 V DC or 100 mA @ 5 V DC.
 MECHANICAL AND ELECTRICAL LIFE: 1,000 cycles at rated loads.
 CONTACT RESISTANCE: 50 mΩ max. initial.
 INSULATION RESISTANCE: 100 MΩ between terminals.
 DIELECTRIC WITHSTANDING VOLTAGE: 300 V DC min. for 1 minute.
 STORAGE TEMPERATURE: -40°C to 85°C.
 OPERATING TEMPERATURE: -40°C to 85°C.
 OPERATING FORCE: 800 grams max.
 SOLDERABILITY: Dip and look solderability testing per C&K spec. #448. Unplated edges of terminals permitted.
 PACKAGING: Switches supplied in rigid dispensing tubes in full-tube quantities only, this may affect order quantity. Numbers of switches per tube varies with model. Tape and reel packaging also available for surface mount options.

Materials

HOUSING: PPS, color black (UL94V-0).
 COVER: PPS, color black (UL94V-0).
 ACTUATOR: PA6T (UL94-0)
 CONTACTS: Gold plated Beryllium copper.
 TERMINALS: Gold plate over nickel plated brass.
 TAPE SEAL: Polyimide.

Note: Specifications and materials listed above are for switches with standard options. For information on specific and custom switches, consult Customer Service Center. For Tin Lead options consult customer service center.

How To Order

The Build-A Switch concept allows you to mix and match options to create the switch you need. Below is a complete listing of options shown in catalog. To order, simply select desired option from each category and place in the appropriate box.

All switches supplied in "OFF" position..

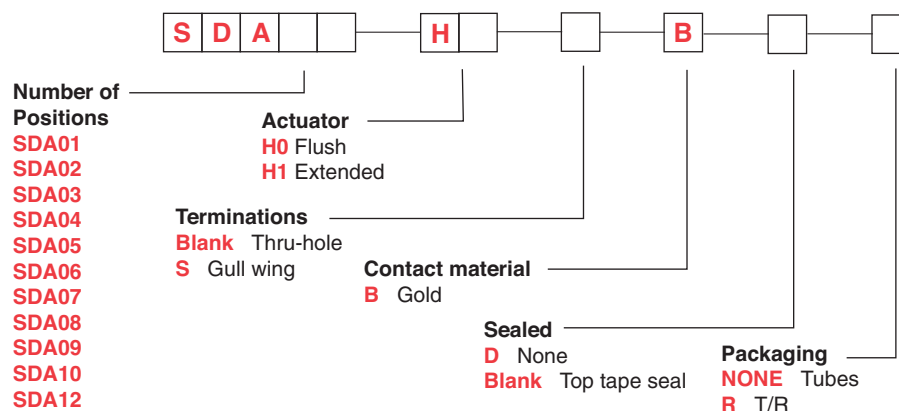

Dimensions are shown: Inch (mm)
 Specifications and dimensions subject to change



SDA Series Low Profile DIP Switches



DIP

Flush Actuator – No Tape, Thru-hole Terminals

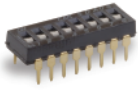

SDA08H0BD

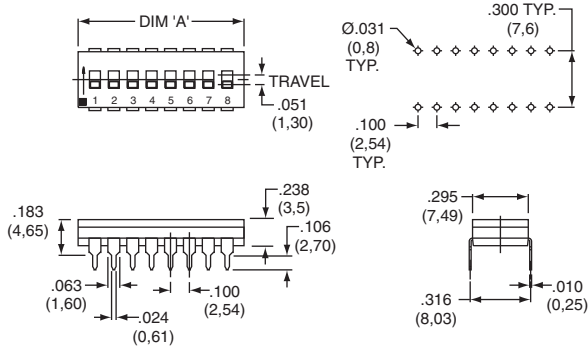

NOTE: SDA 01 options are 4,25mm thick

| ROHS PART NUMBER | NO. POS. | DIM. 'A' | QUANTITY PER TUBE |
|------------------|----------|---------------|-------------------|
| SDA01H0BD | 1 | .178 (4,52) | 100 |
| SDA02H0BD | 2 | .278 (7,06) | 60 |
| SDA03H0BD | 3 | .378 (9,60) | 45 |
| SDA04H0BD | 4 | .476 (12,10) | 35 |
| SDA05H0BD | 5 | .578 (14,68) | 30 |
| SDA06H0BD | 6 | .676 (17,18) | 25 |
| SDA07H0BD | 7 | .778 (19,76) | 20 |
| SDA08H0BD | 8 | .876 (22,26) | 20 |
| SDA09H0BD | 9 | .978 (24,84) | 15 |
| SDA10H0BD | 10 | 1.076 (27,34) | 15 |
| SDA12H0BD | 12 | 1.279 (32,50) | 14 |

Schematic

SPST

Flush Actuator – With Top Tape, Thru-hole Terminals

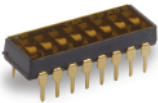

SDA08H0B

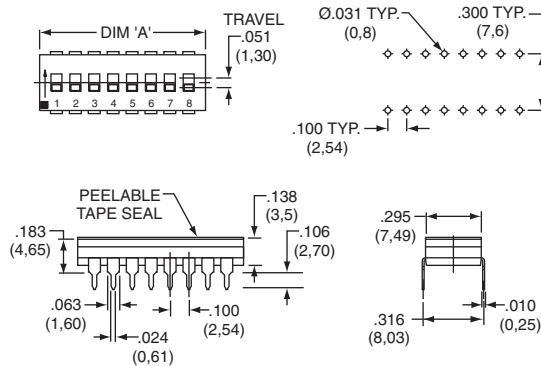

NOTE: SDA 01 options are 4,25mm thick

| ROHS PART NUMBER | NO. POS. | DIM. 'A' | QUANTITY PER TUBE |
|------------------|----------|---------------|-------------------|
| SDA01H0B | 1 | .178 (4,52) | 100 |
| SDA02H0B | 2 | .278 (7,06) | 60 |
| SDA03H0B | 3 | .378 (9,60) | 45 |
| SDA04H0B | 4 | .476 (12,10) | 35 |
| SDA05H0B | 5 | .578 (14,68) | 30 |
| SDA06H0B | 6 | .676 (17,18) | 25 |
| SDA07H0B | 7 | .778 (19,76) | 20 |
| SDA08H0B | 8 | .876 (22,26) | 20 |
| SDA09H0B | 9 | .978 (24,84) | 15 |
| SDA10H0B | 10 | 1.076 (27,34) | 15 |
| SDA12H0B | 12 | 1.279 (32,50) | 14 |

Schematic

SPST



Third Angle Projection

Dimensions are shown: Inch (mm)
Specifications and dimensions subject to change

SDA Series Low Profile DIP Switches



Flush Actuator – With Top Tape, Surface Mount Terminals

| ROHS PART NUMBER | NO. POS. | DIM. 'A' | QUANTITY PER TUBE |
|------------------|----------|---------------|-------------------|
| SDA01H0SB | 1 | .178 (4,52) | 100 |
| SDA02H0SB | 2 | .278 (7,06) | 60 |
| SDA03H0SB | 3 | .378 (9,60) | 45 |
| SDA04H0SB | 4 | .476 (12,10) | 35 |
| SDA05H0SB | 5 | .578 (14,68) | 30 |
| SDA06H0SB | 6 | .676 (17,18) | 25 |
| SDA07H0SB | 7 | .778 (19,76) | 20 |
| SDA08H0SB | 8 | .876 (22,26) | 20 |
| SDA09H0SB | 9 | .978 (24,84) | 15 |
| SDA10H0SB | 10 | 1.076 (27,34) | 15 |
| SDA12H0SB | 12 | 1.279 (32,50) | 14 |

Schematic

SPST

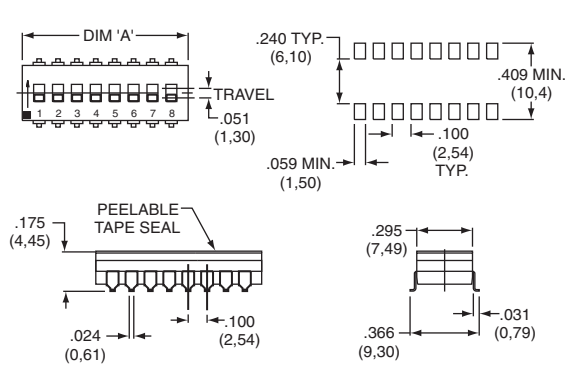

NOTE: SDA 01 options are 4,25mm thick

Flush Actuator – No Tape, Surface Mount Terminals

| ROHS PART NUMBER | NO. POS. | DIM. 'A' | QUANTITY PER TUBE |
|-------------------|----------|---------------|-------------------|
| SDA01H0SBD | 1 | .178 (4,52) | 100 |
| SDA02H0SBD | 2 | .278 (7,06) | 60 |
| SDA03H0SBD | 3 | .378 (9,60) | 45 |
| SDA04H0SBD | 4 | .476 (12,10) | 35 |
| SDA05H0SBD | 5 | .578 (14,68) | 30 |
| SDA06H0SBD | 6 | .676 (17,18) | 25 |
| SDA07H0SBD | 7 | .778 (19,76) | 20 |
| SDA08H0SBD | 8 | .876 (22,26) | 20 |
| SDA09H0SBD | 9 | .978 (24,84) | 15 |
| SDA10H0SBD | 10 | 1.076 (27,34) | 15 |
| SDA12H0SBD | 12 | 1.279 (32,50) | 14 |

Schematic

SPST

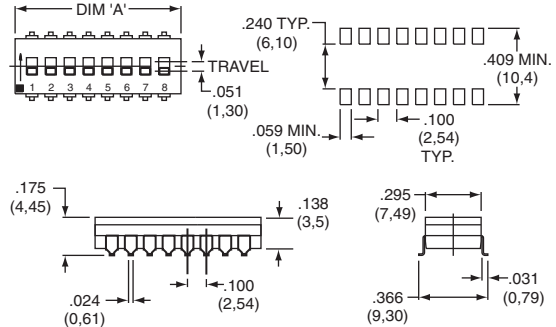

NOTE: SDA 01 options are 4,25mm thick

Extended Actuator – No Top Tape, Thru-hole Terminals

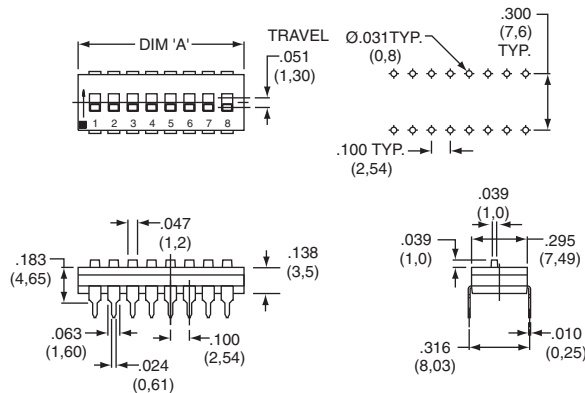

NOTE: SDA 01 options are 4,25mm thick

| ROHS PART NUMBER | NO. POS. | DIM. 'A' | QUANTITY PER TUBE |
|------------------|----------|---------------|-------------------|
| SDA01H1BD | 1 | .178 (4,52) | 100 |
| SDA02H1BD | 2 | .278 (7,06) | 60 |
| SDA03H1BD | 3 | .378 (9,60) | 45 |
| SDA04H1BD | 4 | .476 (12,10) | 35 |
| SDA05H1BD | 5 | .578 (14,68) | 30 |
| SDA06H1BD | 6 | .676 (17,18) | 25 |
| SDA07H1BD | 7 | .778 (19,76) | 20 |
| SDA08H1BD | 8 | .876 (22,26) | 20 |
| SDA09H1BD | 9 | .978 (24,84) | 15 |
| SDA10H1BD | 10 | 1.076 (27,34) | 15 |
| SDA12H1BD | 12 | 1.279 (32,50) | 14 |

Schematic

SPST

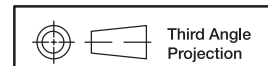

Dimensions are shown: Inch (mm)
Specifications and dimensions subject to change



SDA Series Low Profile DIP Switches

Extended Actuator – No Top Tape, Surface Mount Terminals



SDA08H1SBD

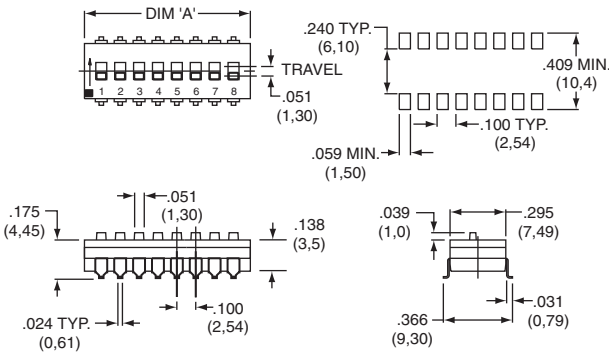

NOTE: SDA 01 options are 4,25mm thick

| ROHS PART NUMBER | NO. POS. | DIM. 'A' | QUANTITY PER TUBE |
|------------------|----------|---------------|-------------------|
| SDA01H1SBD | 1 | .178 (4,52) | 100 |
| SDA02H1SBD | 2 | .278 (7,06) | 60 |
| SDA03H1SBD | 3 | .378 (9,60) | 45 |
| SDA04H1SBD | 4 | .476 (12,10) | 35 |
| SDA05H1SBD | 5 | .578 (14,68) | 30 |
| SDA06H1SBD | 6 | .676 (17,18) | 25 |
| SDA07H1SBD | 7 | .778 (19,76) | 20 |
| SDA08H1SBD | 8 | .876 (22,26) | 20 |
| SDA09H1SBD | 9 | .978 (24,84) | 15 |
| SDA10H1SBD | 10 | 1.076 (27,34) | 15 |
| SDA12H1SBD | 12 | 1.279 (32,50) | 14 |

Schematic

SPST

Tape & Reel Packaging – Surface Mount Options only

| MODEL NO. 'S' OPTION | DIM. 'H' (REF.) | DIM. 'W1' (REF.) | DIM. 'W2' (REF.) | DIM. 'B' (REF.) | DIM. 'C' (REF.) | DIM. 'D' (REF.) | QUANTITY PER REEL |
|-------------------------|--------------------|---------------------|--|--------------------|--------------------|--------------------|-------------------|
| SDA01 | H0 | 5.2 | 24.0 | 24.4 | 8.5 | N/A | 1500 |
| | H1 | 5.8 | | | | | 1450 |
| SDA02 | H0 | 4.8 | 24.0 | 24.4 | 7.9 | N/A | 750 |
| | H1 | 5.8 | | | | | 700 |
| SDA03 | H0 | 4.8 | 24.0 | 24.4 | 10.4 | N/A | 750 |
| | H1 | 5.8 | | | | | 700 |
| SDA04 | H0 | 4.8 | 24.0 | 24.4 | 12.9 | N/A | 750 |
| | H1 | 5.8 | | | | | 700 |
| SDA05 | H0 | 4.8 | 24.0 | 24.4 | 15.4 | N/A | 750 |
| | H1 | 5.8 | | | | | 700 |
| SDA06 | H0 | 4.8 | 32.0 | 32.4 | 18.0 | 28.4 | 750 |
| | H1 | 5.8 | | | | | 700 |
| SDA07 | H0 | 4.8 | 32.0 | 32.4 | 20.5 | 28.4 | 750 |
| | H1 | | NOT CURRENTLY AVAILABLE IN TAPE AND REEL | | | | |
| SDA08 | H0 | 4.8 | 44.0 | 44.4 | 22.7 | 40.4 | 750 |
| | H1 | 5.8 | | | | | 700 |
| SDA09 | H0 | 4.8 | 44.0 | 44.4 | 25.5 | 40.4 | 750 |
| | H1 | 5.8 | | | | | 700 |
| SDA10 | H0 | 4.8 | 44.0 | 44.0 | 28.1 | 40.4 | 750 |
| | H1 | 5.8 | | | | | 700 |
| SDA12 | H0 | 4.8 | 44.0 | 44.4 | 33.2 | 40.4 | 750 |
| | H1 | | NOT CURRENTLY AVAILABLE IN TAPE AND REEL | | | | |

SDA01H1SBD OPTION SHOWN

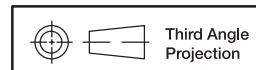
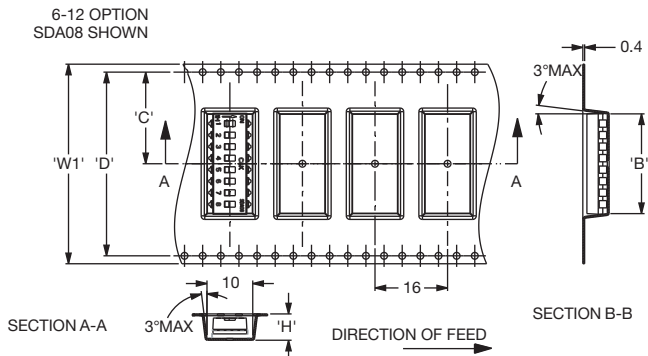
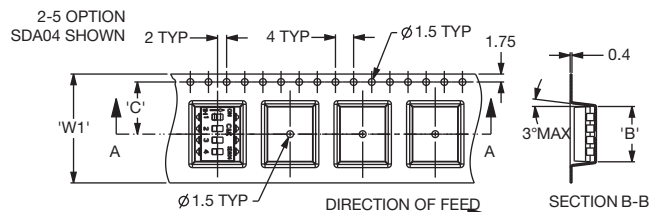
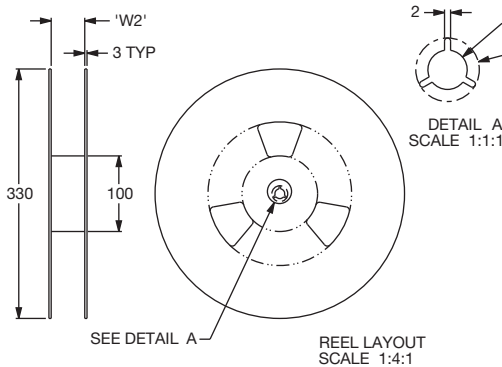
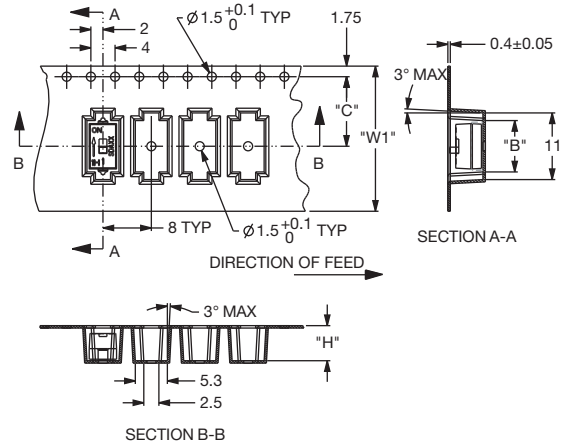

Dimensions are shown: Inch (mm)
Specifications and dimensions subject to change



SD Series Low Profile DIP Switches



Features/Benefits

- Low profile design saves space
- Thru-hole and surface mount models
- Tape and reel packaging available
- Sealed with top tape
- RoHS compliant

Typical Applications

- Address switch for industrial controls
- Logic switching for computers and peripherals
- Function controlling for numerous applications

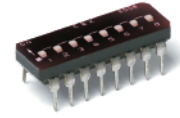

Specifications

SWITCH FUNCTION: SPST - 2, 3, 4, 5, 6, 7, 8, 9, 10 & 12 positions

CONTACT RATING:

Carry: 100 mA @ 50 V DC max.

Switch: 0.1 mA @ 5 V DC min to 100 mA @ 25 V DC max.

MECHANICAL AND ELECTRICAL LIFE: 2,000 make-and-break cycles at full load, each circuit.

CONTACT RESISTANCE: Below 50 milliohms typ. initial @ 2-4 V DC, 100mA.

INSULATION RESISTANCE: 10⁹ ohms min.

DIELECTRIC STRENGTH: 500 V RMS min. @ sea level between adjacent terminals.

STORAGE TEMPERATURE: -40°C to 85°C.

OPERATING TEMPERATURE: -40°C to 85°C.

OPERATING FORCE: 100-700g initial.

PACKAGING: Thru-hole switches supplied in rigid dispensing tubes in full-tube quantities only: this may effect order quantity. Surface mount switches available in tape and reel packaging by added 'R' to end of part number; 1,000 pieces per reel. Switch position 1 denotes pin number 1. All switch actuators in 'OFF' position, standard.

Materials

CASE & COVER: (PPA), flame retardant (UL 94V-0)

ACTUATOR: Nylon, flame retardant (UL 94V-0)

CONTACTS: BeCu with gold plate.

TERMINALS: Bright tin-plated brass.

TERMINAL SEAL: All terminals insert molded.

TAPE SEAL: Polyimide.

Note: Specifications and materials listed above are for switches with standard options. For information on specific and custom switches, consult Customer Service Center.

How To Order

The Build-A Switch concept allows you to mix and match options to create the switch you need. Below is a complete listing of options shown in catalog. To order, simply select desired option from each category and place in the appropriate box.

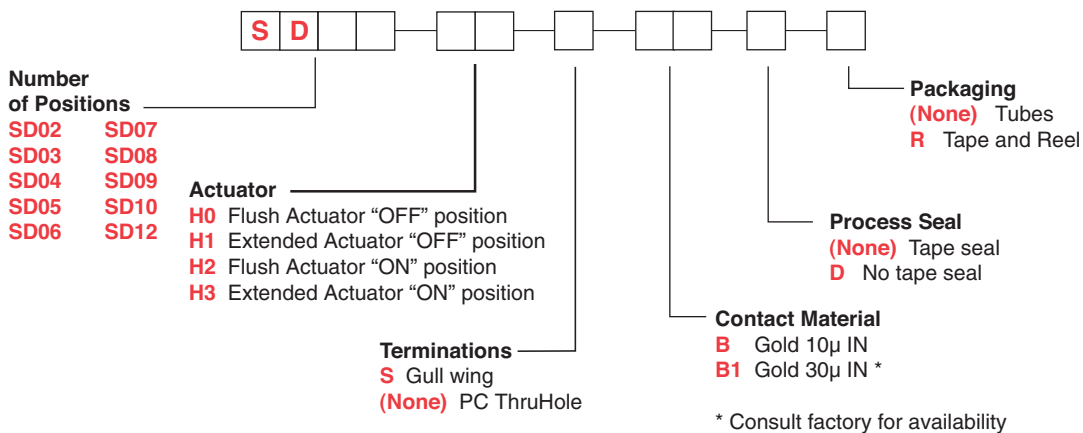

Dimensions are shown: Inch (mm)
Specifications and dimensions subject to change

SD Series Low Profile DIP Switches



DIP

Sealed Flush Actuator – With Top Tape, Thru-hole Terminals

Process sealed - withstands soldering and cleaning processes

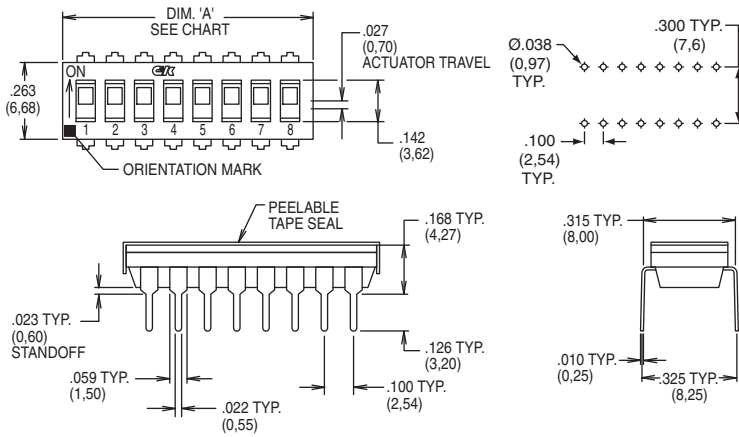

| ROHS PART NUMBER | NO. POS. | DIM. 'A' | QUANTITY PER TUBE |
|------------------|----------|---------------|-------------------|
| SD02H0B | 2 | .258 (6,55) | 85 |
| SD03H0B | 3 | .358 (9,09) | 60 |
| SD04H0B | 4 | .458 (11,63) | 45 |
| SD05H0B | 5 | .558 (14,17) | 40 |
| SD06H0B | 6 | .658 (16,71) | 30 |
| SD07H0B | 7 | .758 (19,25) | 25 |
| SD08H0B | 8 | .858 (21,79) | 25 |
| SD09H0B | 9 | .958 (24,33) | 20 |
| SD10H0B | 10 | 1.058 (26,87) | 20 |
| SD12H0B | 12 | 1.258 (31,95) | 15 |



Table applicable to "H0" and "H2" actuator options.

Sealed Flush Actuator – With Top Tape, Surface Mount Terminals

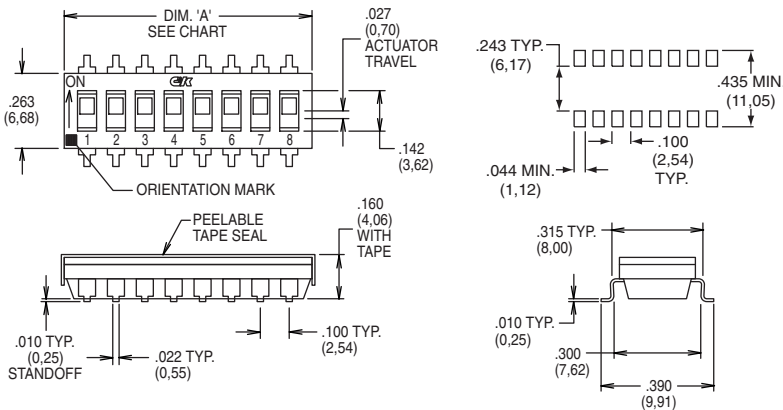

| RoHS PART NUMBER | NO. POS. | DIM. 'A' | QUANTITY PER TUBE |
|------------------|----------|---------------|-------------------|
| SD02H0SB | 2 | .258 (6,55) | 85 |
| SD03H0SB | 3 | .358 (9,09) | 60 |
| SD04H0SB | 4 | .458 (11,63) | 45 |
| SD05H0SB | 5 | .558 (14,17) | 40 |
| SD06H0SB | 6 | .658 (16,71) | 30 |
| SD07H0SB | 7 | .758 (19,25) | 25 |
| SD08H0SB | 8 | .858 (21,79) | 25 |
| SD09H0SB | 9 | .958 (24,33) | 20 |
| SD10H0SB | 10 | 1.058 (26,87) | 20 |
| SD12H0SB | 12 | 1.258 (31,95) | 15 |



Table applicable to "H0" and "H2" actuator options.

Sealed Extended Actuator – With Top Tape, Thru-hole Terminals

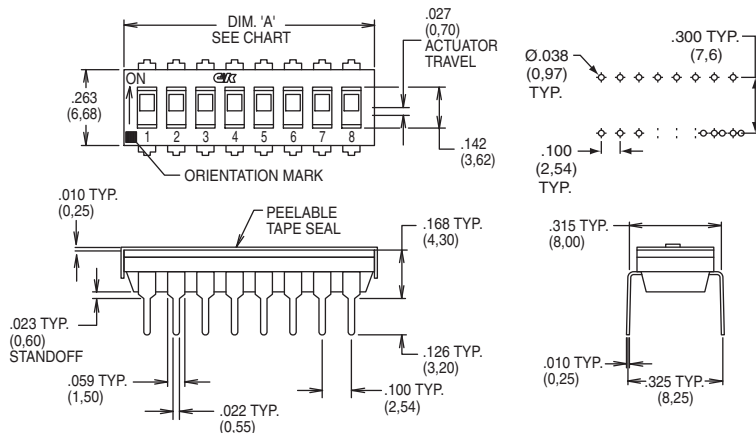

| RoHS PART NUMBER | NO. POS. | DIM. 'A' | QUANTITY PER TUBE |
|------------------|----------|---------------|-------------------|
| SD02H1B | 2 | .258 (6,55) | 85 |
| SD03H1B | 3 | .358 (9,09) | 60 |
| SD04H1B | 4 | .458 (11,63) | 45 |
| SD05H1B | 5 | .558 (14,17) | 40 |
| SD06H1B | 6 | .658 (16,71) | 30 |
| SD07H1B | 7 | .758 (19,25) | 25 |
| SD08H1B | 8 | .858 (21,79) | 25 |
| SD09H1B | 9 | .958 (24,33) | 20 |
| SD10H1B | 10 | 1.058 (26,87) | 20 |
| SD12H1B | 12 | 1.258 (31,95) | 15 |



Table applicable to "H1" and "H3" actuator options.

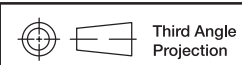

Third Angle Projection

Dimensions are shown: Inch (mm)
Specifications and dimensions subject to change



SD Series Low Profile DIP Switches



Sealed Extended Actuator – With Top Tape, Surface Mount Terminals

| RoHS PART NUMBER | NO. POS. | DIM. 'A' | QUANTITY PER TUBE |
|------------------|----------|---------------|-------------------|
| SD02H1SB | 2 | .258 (6,55) | 85 |
| SD03H1SB | 3 | .358 (9,09) | 60 |
| SD04H1SB | 4 | .458 (11,63) | 45 |
| SD05H1SB | 5 | .558 (14,17) | 40 |
| SD06H1SB | 6 | .658 (16,71) | 30 |
| SD07H1SB | 7 | .758 (19,25) | 25 |
| SD08H1SB | 8 | .858 (21,79) | 25 |
| SD09H1SB | 9 | .958 (24,33) | 20 |
| SD10H1SB | 10 | 1.058 (26,87) | 20 |
| SD12H1SB | 12 | 1.258 (31,95) | 15 |



Table applicable to "H1" and "H3" actuator options.

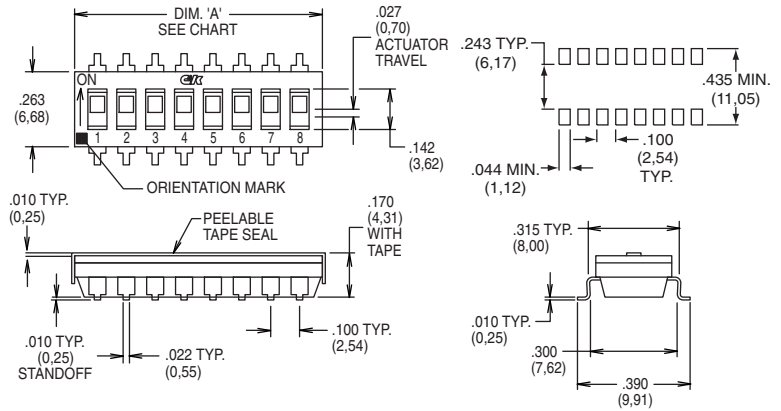

TAPE & REEL PACKAGING – SURFACE MOUNT OPTIONS ONLY

| RoHS PART NUMBER | NO. POS. | DIM. 'A' | QUANTITY PER REEL |
|------------------|----------|---------------|-------------------|
| SD02H0SBR | 2 | .258 (6,55) | 1000 |
| SD03H0SBR | 3 | .358 (9,09) | 1000 |
| SD04H0SBR | 4 | .458 (11,63) | 1000 |
| SD05H0SBR | 5 | .558 (14,17) | 1000 |
| SD06H0SBR | 6 | .658 (16,71) | 1000 |
| SD07H0SBR | 7 | .758 (19,25) | 1000 |
| SD08H0SBR | 8 | .858 (21,79) | 1000 |
| SD09H0SBR | 9 | .958 (24,33) | 1000 |
| SD10H0SBR | 10 | 1.058 (26,87) | 1000 |
| SD12H0SBR | 12 | 1.258 (31,95) | 1000 |



Table applicable to "H0" and "H2" actuator options.

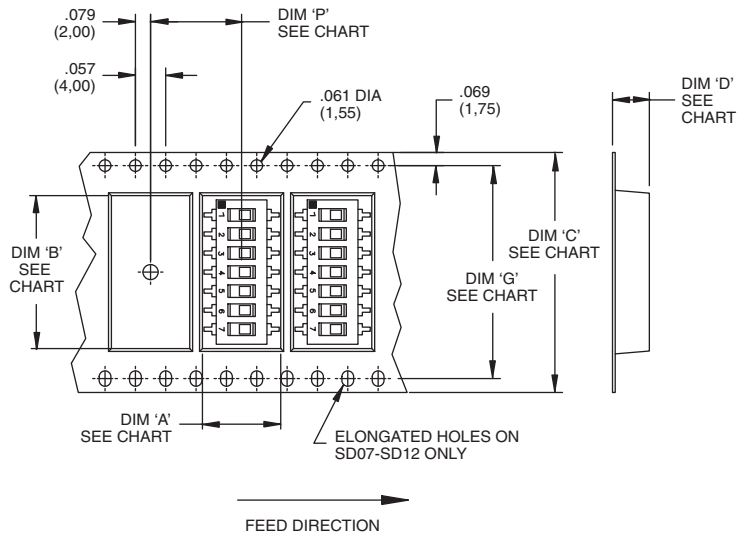

| SWITCH NO. | DIM 'A' POCKET LENGTH @ BOTTOM | DIM 'B' POCKET LENGTH @ BOTTOM | DIM 'C' TAPE WIDTH | DIM 'D' POCKET DEPTH | DIM 'G' SPROCKET HOLE SPACING | DIM 'P' PITCH BETWEEN POCKETS |
|------------|--------------------------------|--------------------------------|--------------------|----------------------|-------------------------------|-------------------------------|
| SD02 | .413(10,5) | .315(8,0) | .630(16,0) | .177(4,5) | N/A | .472(12,0) |
| SD03 | .406(10,3) | .406(10,3) | .630(16,0) | .177(4,5) | N/A | .472(12,0) |
| SD04 | .429(10,9) | .476(12,1) | .954(24,0) | .177(4,5) | N/A | .472(12,0) |
| SD05 | .406(10,3) | .602(15,3) | .954(24,0) | .177(4,5) | N/A | .472(12,0) |
| SD06 | .406(10,3) | .701(17,8) | .954(24,0) | .177(4,5) | N/A | .472(12,0) |
| SD07 | .406(10,3) | .803(20,4) | 1.260(32,0) | .177(4,5) | 1.118(28,4) | .472(12,0) |
| SD08 | .406(10,3) | .854(21,7) | 1.732(44,0) | .177(4,5) | 1.591(40,4) | .472(12,0) |
| SD09 | .406(10,3) | 1.028(26,1) | 1.732(44,0) | .177(4,5) | 1.591(40,4) | .472(12,0) |
| SD10 | .406(10,3) | 1.055(26,8) | 1.732(44,0) | .177(4,5) | 1.591(40,4) | .472(12,0) |
| SD12 | .406(10,3) | 1.303(33,1) | 1.732(44,0) | .177(4,5) | 1.591(40,4) | .472(12,0) |

Reel Information

Outside diameter 13.00 (333,0)
Pilot hole .512 (13,0)



Dimensions are shown: Inch (mm)
Specifications and dimensions subject to change



BD Series Standard Profile DIP Switches



DIP

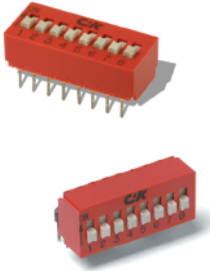

Features/Benefits

- Traditional full profile DIP switch
- Extended actuator for easy actuation
- Open bottom construction allows for solder washing without the need for tape seal
- RoHS compliant

Typical Applications

- Address switch for industrial controls
- Logic switching for computers and peripherals
- Function controlling for numerous applications

Specifications

SWITCH FUNCTION: SPST - 1 thru 12 position available (except 11 position).

CONTACT RATING:

Carry: 100 mA max. @ 50 V DC.

Switch: 100 mA max. @ 5 V DC or 25 mA max. @ 25 V DC.

MECHANICAL AND ELECTRICAL LIFE: 10,000 make-and-break cycles at full load, each circuit.

CONTACT RESISTANCE: Below 50 milliohms typ. initial @ 2-4 V DC 100mA.

INSULATION RESISTANCE: 10⁹ ohms min.

DIELECTRIC STRENGTH: 500 V RMS min. @ sea level between adjacent terminals.

CAPACITANCE: 5pF max. between adjacent terminals.

STORAGE & OPERATING TEMPERATURE: -40°C to 85°C.

SHOCK: Withstands 20g 11 ms sawtooth waveform with no contact opening greater than 10 microseconds.

VIBRATION: No contact opening greater than 10 microseconds and no contact closure when exposed to vibration .06 in DA or 5g, whichever is less, from 10 to 55 Hz, and 10g from 55 to 500 Hz.

SOLDERABILITY: Per MIL-STD-202F method 208D, or EIA RS-186E method 9 (1 hour steam aging).

PACKAGING: Switches supplied in rigid dispensing tubes in full-tube quantities only: this may effect order quantity. Number of switches per tube varies with model. Switch position 1 denotes pin number 1. All switch actuators in 'OFF' position, standard.

Materials

CASE & COVER: Glass filled polyester (PBT), flame retardant (UL 94V-0).

ACTUATOR: Glass filled nylon 6/6, flame retardant, heat stabilized (UL 94V-0)

CONTACTS: Gold over nickel over phosphor bronze.

TERMINALS: Matte-tin over nickel over phosphor bronze.

Note: Specifications and materials listed above are for switches with standard options. For information on specific and custom switches, consult Customer Service Center.

Vertical Full Profile DIP



BD08

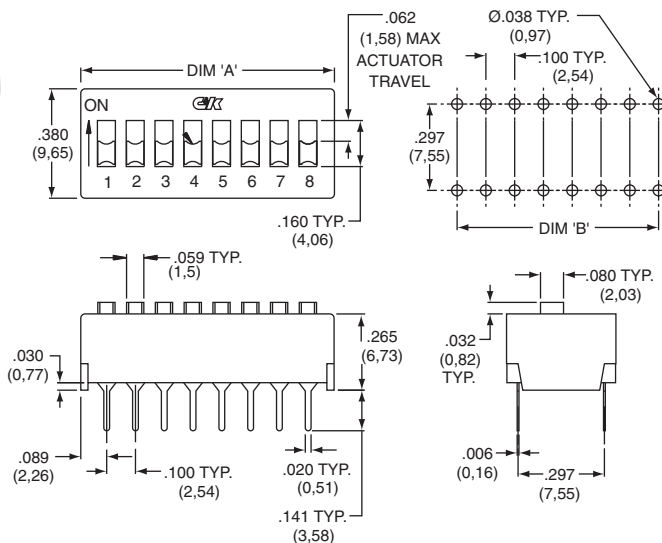

| PART NUMBER | NO.POS. | DIM. 'A' | DIM. 'B' | QUANTITY PER TUBE |
|-------------|---------|---------------|---------------|-------------------|
| BD01 | 1 | .180 (4,57) | NA | 115 |
| BD02 | 2 | .280 (7,11) | .100 (2,54) | 74 |
| BD03 | 3 | .380 (9,65) | .200 (5,08) | 54 |
| BD04 | 4 | .480 (12,19) | .300 (7,62) | 43 |
| BD05 | 5 | .580 (14,73) | .400 (10,16) | 35 |
| BD06 | 6 | .680 (17,27) | .500 (12,75) | 30 |
| BD07 | 7 | .780 (19,81) | .600 (15,24) | 26 |
| BD08 | 8 | .880 (22,35) | .700 (17,78) | 23 |
| BD09 | 9 | .980 (24,89) | .800 (20,32) | 21 |
| BD10 | 10 | 1.080 (27,43) | .900 (22,86) | 19 |
| BD12 | 12 | 1.280 (32,51) | 1.100 (27,94) | 16 |

Schematic

SPST

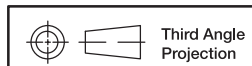

Dimensions are shown: Inch (mm)
Specifications and dimensions subject to change



BD Series Standard Profile DIP Switches

Open Base and AV Right Angle Terminal Style

| PART NUMBER | NO.POS. | DIM. 'A' | QUANTITY PER TUBE |
|---------------|---------|---------------|-------------------|
| BD02AV | 2 | .280 (7,11) | 72 |
| BD03AV | 3 | .380 (9,65) | 52 |
| BD04AV | 4 | .480 (12,19) | 42 |
| BD05AV | 5 | .580 (14,73) | 35 |
| BD06AV | 6 | .680 (17,27) | 29 |
| BD07AV | 7 | .780 (19,81) | 26 |
| BD08AV | 8 | .880 (22,35) | 23 |
| BD09AV | 9 | .980 (24,89) | 20 |
| BD10AV | 10 | 1.080 (27,43) | 18 |
| BD12AV | 12 | 1.280 (32,51) | 15 |

Schematic

SPST

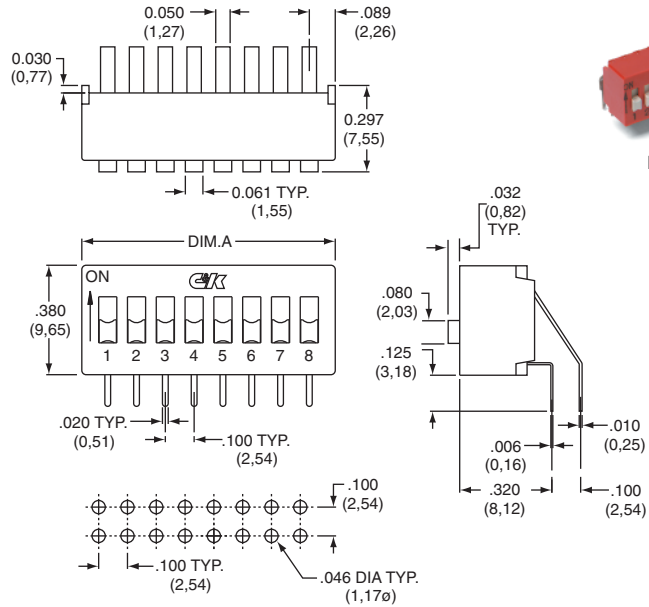

BD08AV

H
DIP

Installation, Soldering and Cleaning

All BD Series Standard Profile DIP Switches can be hand soldered or machine soldered without the use of boot, caps, tapes or special attention. Open base washable models have unique design, allowing solvent cleaners and water/detergent solutions to flush and clean the electrical contacts of the contaminants and fluxes. For best results, follow these directions:

- 1) Wave soldering recommended at 500° F (260°C) solder temperature.
- 2) Hand solder using 30 watt small tip iron controlled at 500° F (260°C), 10 seconds max./terminal.
- 3) Open base washable models: Clean flux using forced rinse, high agitation or triple bath cleaning method.
DO NOT mask or cover switch in any way during cleaning. Switch is designed for easy solvent flush out.
- 4) All switch actuators must be in 'OFF' position during soldering and cleaning processes.

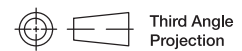

Third Angle
Projection

Dimensions are shown: Inch (mm)
Specifications and dimensions subject to change



BPA Series Side Actuated DIP Switches

10
9
8
7
6
5
4
3
2
1

H

DIP

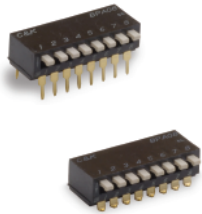

Features/Benefits

- Side actuated contacts
- Available in thru-hole or SMT models
- High pressure contact system does not require tape seal for washing
- RoHS compliant & compatible

Typical Applications

- Address switch for industrial controls
- Logic switching for computers and peripherals
- Function controlling for numerous applications

Specifications

SWITCH FUNCTION: 1 thru 10 and 12 position available.
 CONTACT RATING: 100 mA max. @ 5 V DC or 25 mA max. @ 24 V DC.
 MECHANICAL AND ELECTRICAL LIFE: 1,000 cycles min. @ 5 V DC 10mA.
 CONTACT RESISTANCE: 50 milliohms initial max.
 INSULATION RESISTANCE: 100 V DC 100 megohms min.
 DIELECTRIC WITHSTAND VOLTAGE: 300 V AC for 1 minute.
 STORAGE TEMPERATURE: -40°C to 85°C.
 OPERATING TEMPERATURE: -20°C to 85°C.
 OPERATING FORCE: 800 grams max.
 SOLDERABILITY: Flow solderable and washable (soldering: 260°C for 10 sec. max.)

PACKAGING: Switches supplied in rigid dispensing tubes in full-tube quantities only, this may affect order quantity. Numbers of switches per tube varies with model. Tape and reel packaging available for SMT options.

Materials

HOUSING: PPS, color black (UL94V-0).
 COVER: PPS, color black (UL94V-0).
 ACTUATOR: PA-6T UL94V-0).
 CONTACTS: Beryllium Copper with Gold over Nickel plate.
 TERMINALS: Brass, Gold over Nickel plate.

Note: Specifications and materials listed above are for switches with standard options. For information on specific and custom switches, consult Customer Service Center.

How To Order

The Build-A Switch concept allows you to mix and match options to create the switch you need. Below is a complete listing of options shown in catalog. To order, simply select desired option from each category and place in the appropriate box.

All switches supplied in "OFF" position.

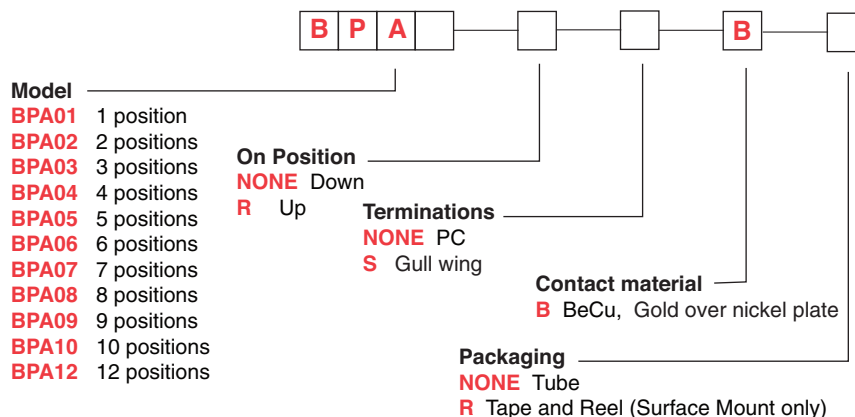

Dimensions are shown: Inch (mm)
 Specifications and dimensions subject to change

BPA Series Side Actuated DIP Switches

Side Actuator – Thru-hole Terminals

| ROHS PART NUMBER | NO. POS. | DIM. 'A' | DIM. 'B' | QUANTITY PER TUBE |
|------------------|----------|--------------|---------------|-------------------|
| BPA01B | 1 | .176 (4,48) | N/A | 100 |
| BPA02B | 2 | .276 (7,0) | .100 (2,54) | 60 |
| BPA03B | 3 | .376 (9,6) | .200 (5,08) | 45 |
| BPA04B | 4 | .476 (12,1) | .300 (7,62) | 35 |
| BPA05B | 5 | .575 (14,6) | .400 (10,16) | 30 |
| BPA06B | 6 | .677 (17,2) | .500 (12,70) | 25 |
| BPA07B | 7 | .776 (19,7) | .600 (15,24) | 20 |
| BPA08B | 8 | .878 (22,3) | .700 (17,78) | 20 |
| BPA09B | 9 | .976 (24,8) | .800 (20,32) | 15 |
| BPA10B | 10 | 1.075 (27,3) | .900 (22,86) | 15 |
| BPA12B | 12 | 1.280 (32,5) | 1.100 (27,94) | 14 |



SPST

NOTE: Reverse throw available, contact C&K for P/N and quote.

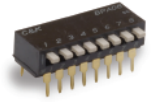

BPA08B

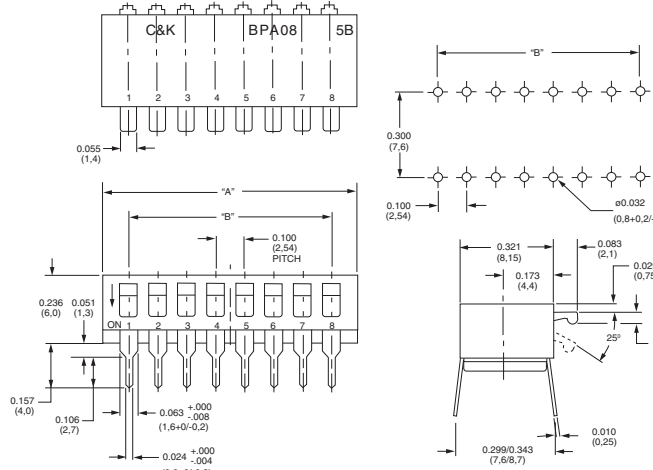

Side Actuator – Surface Mount Terminals

| ROHS PART NUMBER | NO. POS. | DIM. 'A' | DIM. 'B' | QUANTITY PER TUBE |
|------------------|----------|--------------|---------------|-------------------|
| BPA01SB | 1 | .176 (4,48) | N/A | 100 |
| BPA02SB | 2 | .276 (7,0) | .100 (2,54) | 60 |
| BPA03SB | 3 | .376 (9,6) | .200 (5,08) | 45 |
| BPA04SB | 4 | .476 (12,1) | .300 (7,62) | 35 |
| BPA05SB | 5 | .575 (14,6) | .400 (10,16) | 30 |
| BPA06SB | 6 | .677 (17,2) | .500 (12,70) | 25 |
| BPA07SB | 7 | .776 (19,7) | .600 (15,24) | 20 |
| BPA08SB | 8 | .878 (22,3) | .700 (17,78) | 20 |
| BPA09SB | 9 | .976 (24,8) | .800 (20,32) | 15 |
| BPA10SB | 10 | 1.075 (27,3) | .900 (22,86) | 15 |
| BPA12SB | 12 | 1.280 (32,5) | 1.100 (27,94) | 14 |



SPST

NOTE: Tape and reel packaging available by adding "R" to end of project number.



BPA08SB

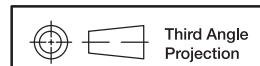
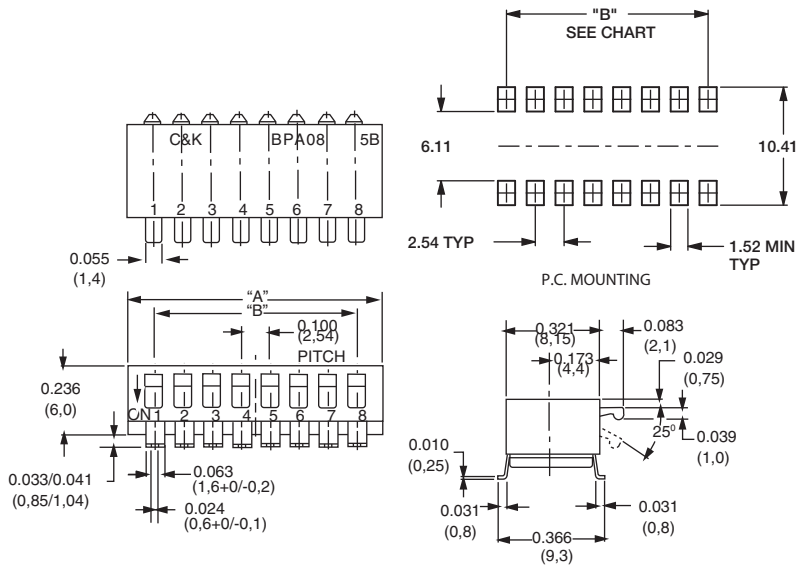

Dimensions are shown: Inch (mm)
Specifications and dimensions subject to change



BPA Series Side Actuated DIP Switches

Tape & Reel Packaging – Surface Mount Options Only

| QTY/ REEL | POLES | DIM. 'A' | DIM. 'B' | DIM. 'C' | DIM. 'D' | DIM. 'E' |
|--------------|-------|-------------|--------------|--------------|--------------|--------------|
| 500 | 1 | .453 (11,5) | — | .945 (24,0) | .530 (13,45) | .960 (24,4) |
| 500 | 2 | .453 (11,5) | — | .945 (24,0) | .311 (7,9) | .960 (24,4) |
| 500 | 3 | .453 (11,5) | — | .945 (24,0) | .409 (10,4) | .960 (24,4) |
| 500 | 4 | .453 (11,5) | — | .945 (24,0) | .508 (12,9) | .960 (24,4) |
| 500 | 5 | .453 (11,5) | — | .945 (24,0) | .606 (15,4) | .960 (24,4) |
| 500 | 6 | .559 (14,2) | 1.118 (28,4) | 1.260 (32,0) | .709 (18,0) | 1.275 (32,4) |
| 500 | 7 | .559 (14,2) | 1.118 (28,4) | 1.260 (32,0) | .807 (20,5) | 1.275 (32,4) |
| 500 | 8 | .795 (20,2) | 1.590 (40,4) | 1.732 (44,0) | .894 (22,7) | 1.748 (44,4) |
| 500 | 9 | .795 (20,2) | 1.590 (40,4) | 1.732 (44,0) | 1.004 (25,5) | 1.748 (44,4) |
| 500 | 10 | .795 (20,2) | 1.590 (40,4) | 1.732 (44,0) | 1.106 (28,1) | 1.748 (44,4) |
| 500 | 12 | .795 (20,2) | 1.590 (40,4) | 1.732 (44,0) | 1.311 (33,3) | 1.748 (44,4) |

Note: For tape and reel packaging, add 'R' to end of part number.

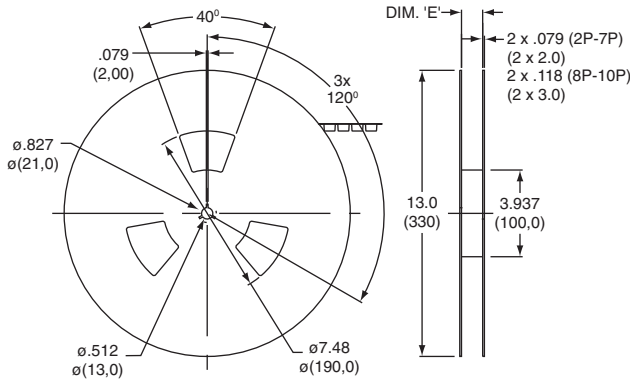

Tube Packaging

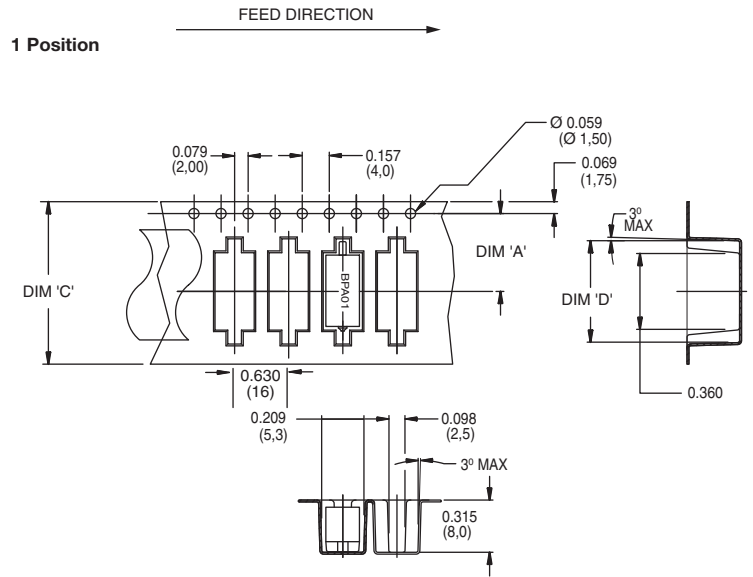
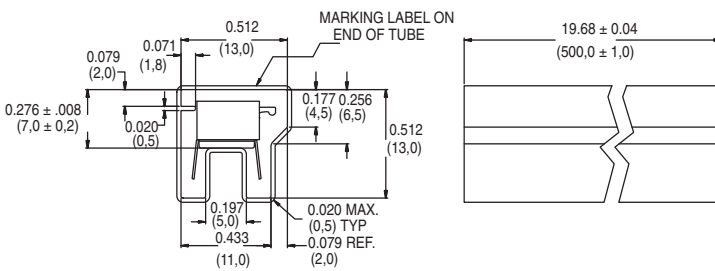

2, 3, 4 & 5 Positions

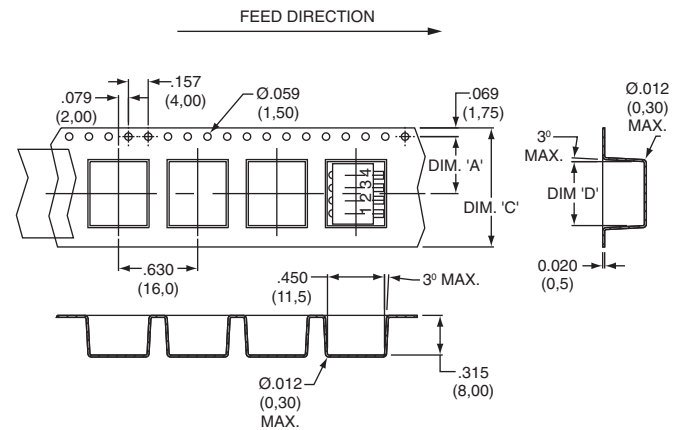

6, 7, 8, 9, 10 & 12 Positions

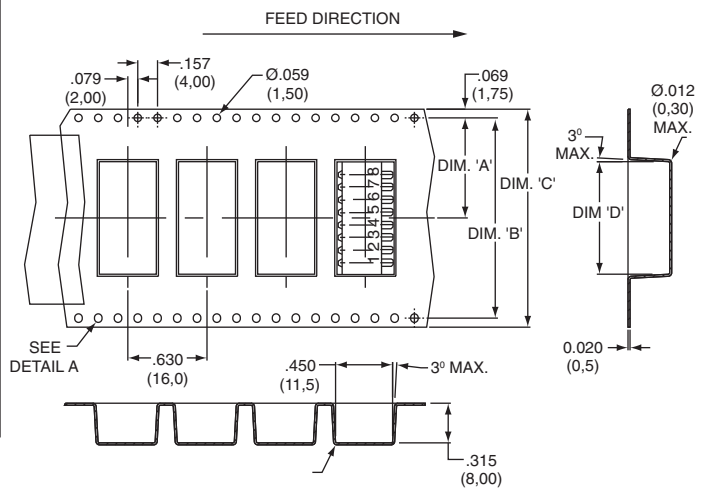

Dimensions are shown: Inch (mm)
Specifications and dimensions subject to change

TDD Series Jumper Switch



H

DIP

Features/Benefits

- **Bifurcated contact for increased electrical reliability**
- **Process sealed for surface mount soldering and washable processing**
- **RoHS compliant**

Typical Applications

- **Hand-held electronic devices**
- **Portable computer and electronic devices**
- **Instrumentation and controls**
- **Inverters**



Specifications

CONTACT RATING: 25 mA @ 24 V DC (switching) or 100 mA @ 50 V DC (steady state).
 MECHANICAL AND ELECTRICAL LIFE: 200 cycles at rated loads.
 CONTACT RESISTANCE: 100 mΩ max. initial. @ 2 V DC /10 mA
 INSULATION RESISTANCE: 100 MΩ @ 100 V DC min.
 DIELECTRIC STRENGTH: 300 V AC /minute
 STORAGE TEMPERATURE: -40°C to 85°C.
 OPERATING TEMPERATURE: -30°C to 85°C.
 OPERATING FORCE: 4.9 N max.
 SOLDERABILITY: Per MIL-STD-202F method 208D, or EIA RS-186E method 9 (1 hour steam aging).
 PACKAGING: 1,000 pieces tape & reel

Materials

CASE AND COVER: PPS, color black (UL94V-0).
 ACTUATOR: LCP (UL94-0)
 CONTACTS: Copper alloy with gold plate over nickel plate
 TERMINALS (INSERT MOLDED): Copper alloy gold flash over nickel plate
 TAPE SEAL: Polyamide

Note: Specifications and materials listed above are for switches with standard options. For information on specific and custom switches, consult Customer Service Center. For Tin Lead options consult customer service center.

How To Order

The Build-A Switch concept allows you to mix and match options to create the switch you need. Below is a complete listing of options shown in catalog. To order, simply select desired option from each category and place in the appropriate box.

All switches supplied in "OFF" position..

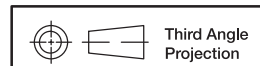
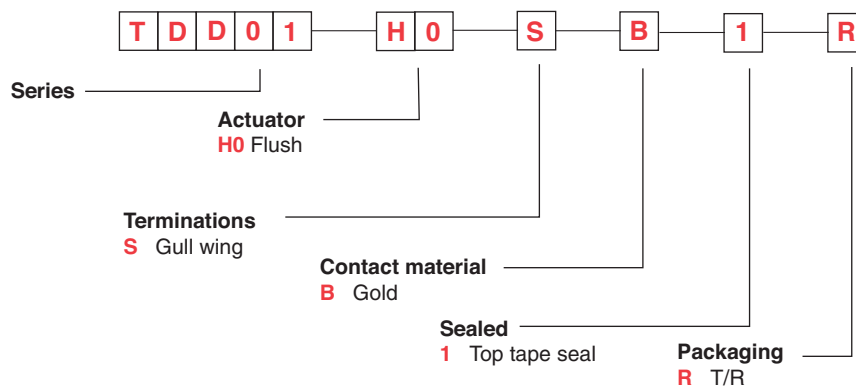

Third Angle Projection
 Dimensions are shown: Inch (mm)
 Specifications and dimensions subject to change



TDD Series Jumper Switch



DIP

H

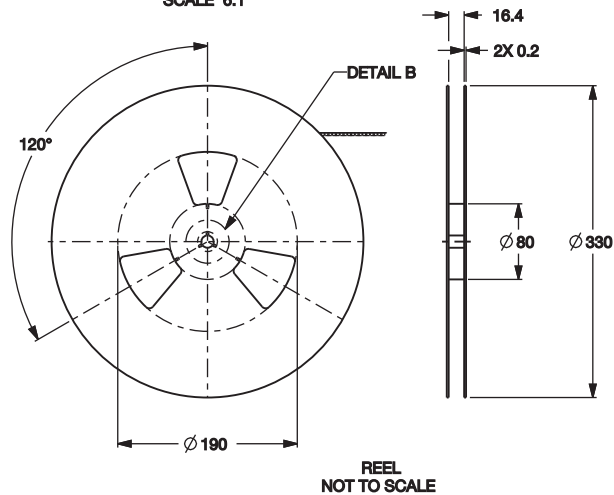
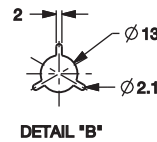
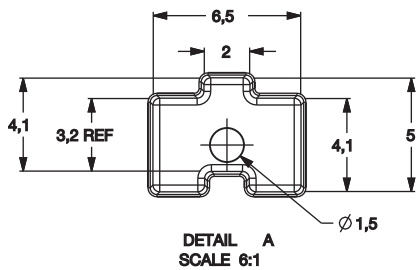
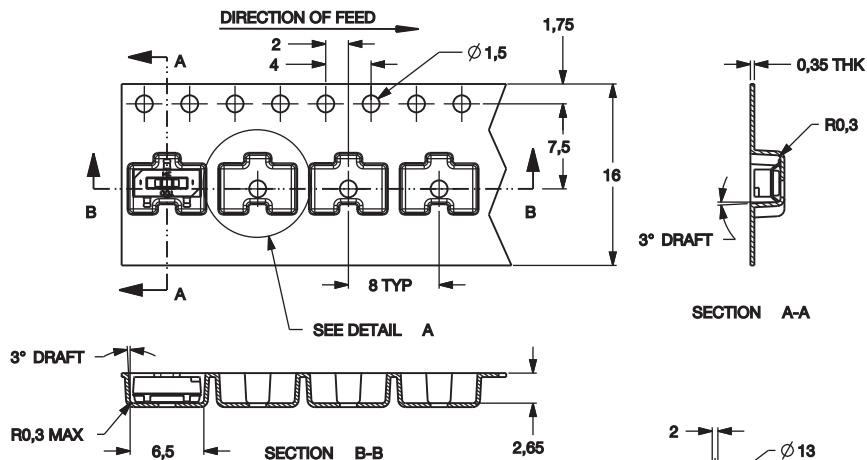
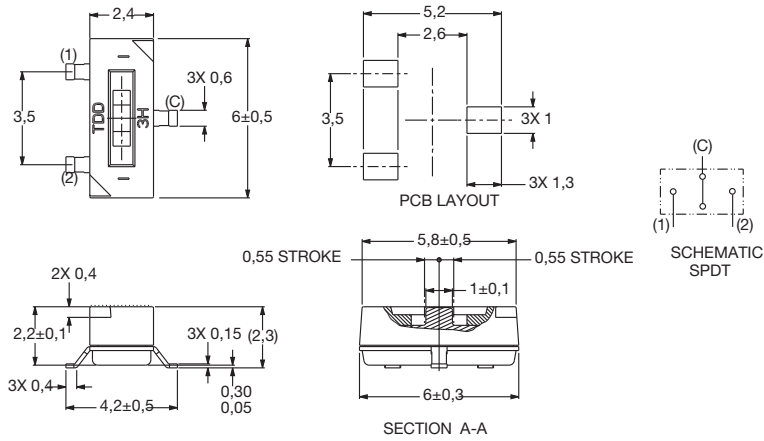

Third Angle
Projection

Dimensions are shown: Inch (mm)
Specifications and dimensions subject to change

SPA Series Single In-line Package Switches



Features/Benefits

- **Thin Single In-line Packaging saves PCB space**
- **Retention feature holds part to PCB prior to soldering**
- **Available in vertical or right angle models**
- **High pressure contact system does not require tape sealing**
- **RoHS compliant**

Typical Applications

- **Address switch for industrial controls**
- **Logic switching for computers and peripherals**
- **Function controlling for numerous applications**



Specifications

CONTACT RATING:

Carry: 10 mA @ 5VDC

Switching: 0.1 mA @ 0.1m VDC min.

MECHANICAL AND ELECTRICAL LIFE: 1,000 cycles min.

CONTACT RESISTANCE: 50 mΩ max. @ 20 V DC 10mA.

INSULATION RESISTANCE: 100 MΩ min. @ 100 V DC.

DIELECTRIC STRENGTH: 1 minute @ 300 V AC.

CAPACITANCE: 5pF max. between adjacent terminals.

OPERATING TEMPERATURE: -30°C to 60°C.

STORAGE TEMPERATURE: -30°C to 80°C.

OPERATING FORCE: 5.9N max.

SOLDERABILITY: Dip & look solderability testing per C&K spec. #448. Unplated edges of terminals permitted.

PACKAGING: Switches supplied in rigid dispensing tubes in full-tube quantities only, this may affect order quantity. Numbers of switches per tube varies with model.

Materials

BASE: PPS (UL94V-0).

COVER: PBT (UL94V-0).

ACTUATOR: 4/6 Nylon (UL 94V-0).

MOVABLE CONTACT: Beryllium copper alloy, gold over nickel plate.

FIXED CONTACT: Copper alloy, gold over nickel plate.

CLIP: Phosphor bronze wire. Phosphor bronze, Tin over nickel plate.

Note: Specifications and materials listed above are for switches with standard options. For information on specific and custom switches, consult Customer Service Center.

How To Order

The Build-A Switch concept allows you to mix and match options to create the switch you need. Below is a complete listing of options shown in catalog. To order, simply select desired option from each category and place in the appropriate box.

All switches supplied in "OFF" position.

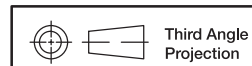
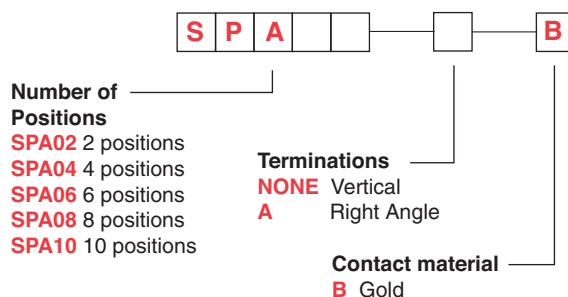

Dimensions are shown: Inch (mm)
Specifications and dimensions subject to change



SPA Series Single In-line Package Switches

Vertical



DIP H

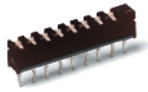

SPA08B

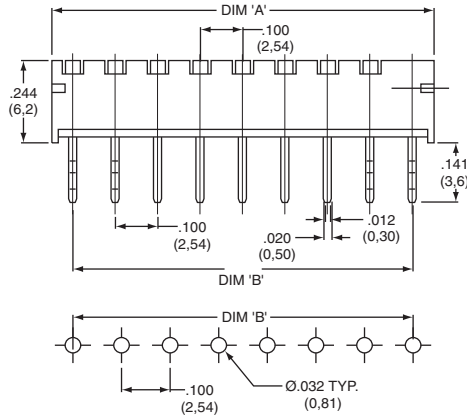
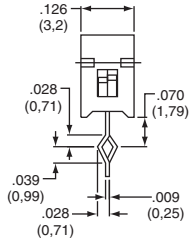

| ROHS PART NUMBER | NO. POS. | DIM. 'A' | DIM. 'B' | QUANTITY PER TUBE |
|------------------|----------|---------------|---------------|-------------------|
| SPA02B | 2 | .342 (8,68) | .200 (5,08) | 50 |
| SPA04B | 4 | .542 (13,76) | .400 (10,16) | 30 |
| SPA06B | 6 | .742 (18,84) | .600 (15,24) | 25 |
| SPA08B | 8 | .942 (23,92) | .800 (20,32) | 20 |
| SPA10B | 10 | 1.142 (29,00) | 1.000 (25,40) | 15 |

Schematic

SPST



SPA08AB

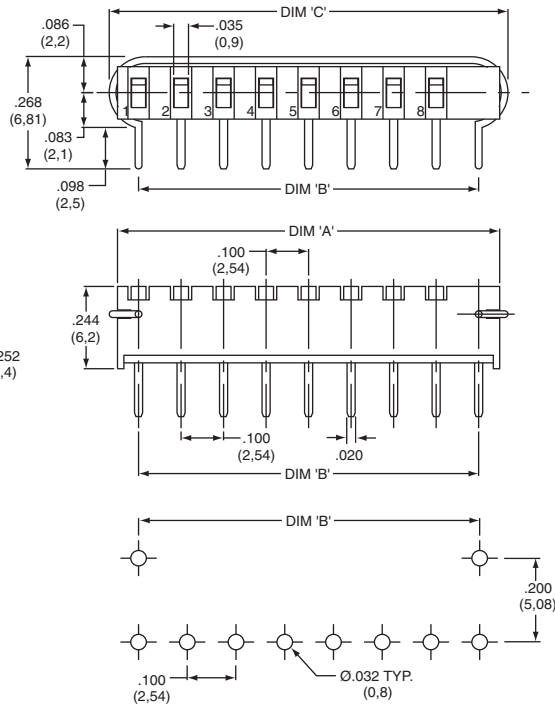
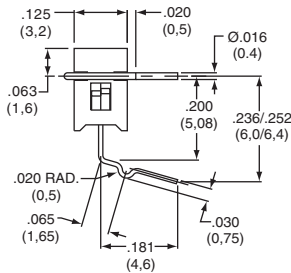

| ROHS PART # | NO. POS. | DIM. 'A' | DIM. 'B' | DIM. 'C' | QTY PER TUBE |
|----------------|----------|---------------|---------------|--------------|--------------|
| SPA02AB | 2 | .342 (8,68) | .200 (5,08) | .339 (8,6) | 50 |
| SPA04AB | 4 | .542 (13,76) | .400 (10,16) | .540 (13,7) | 30 |
| SPA06AB | 6 | .742 (18,84) | .600 (15,24) | .736 (18,7) | 25 |
| SPA08AB | 8 | .942 (23,92) | .800 (20,32) | .937 (23,8) | 20 |
| SPA10AB | 10 | 1.142 (29,00) | 1.000 (25,40) | 1.138 (28,9) | 15 |

Schematic

SPST

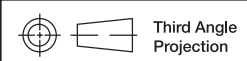

Third Angle Projection

Dimensions are shown: Inch (mm)
Specifications and dimensions subject to change



RTE Series Low Profile Rotary DIP Switches



Features/Benefits

- Thru-hole and surface mount models
- Miniature size with robust metal cover in black or silver nickel finish
- 4, 10, & 16 positions
- Large choice of codings
- Vertical or reverse versions
- RoHS compliant

Typical Applications

- Timers, automation components
- Computer and peripherals
- Alarms, access control, smoke detectors
- Instrumentation

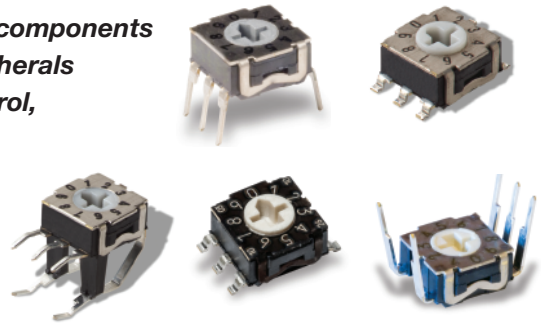

Specifications

CONTACT RATING:
Gold: 100 mA max. 10µ A min. 30 V DC max. 20 mVDC min.
MECHANICAL LIFE: 20,000 actuations
CONTACT RESISTANCE: 100 mΩ max. initial;
150 mΩ after life
INSULATION RESISTANCE: 10¹⁰ Ω min. initial
DIELECTRIC STRENGTH: 300 Vrms 1 mn
OPERATING TEMPERATURE: -25°C to 85°C.
STORAGE TEMPERATURE: -40°C to 85°C.
PACKAGING: N or R terminations in tube.
V termination in box. G termination in reel, 750 pieces per reel. G termination with flush actuator, 1250 pieces per reel.

Materials

COVER: Brass, nickel plated (black or silver)
BASE: PPS
ACTUATOR: LCP
MOVABLE CONTACTS: Bronze, gold plated.
STATIONARY CONTACTS: Brass, gold plated.
TERMINALS: See page I-28 to I-29
O-RING: Silicone

Note: Specifications and materials listed above are for switches with standard options. For information on specific and custom switches, consult Customer Service Center.

Solderability: Wave soldering 260°/10 s.
SMT are reflow compatible according to C&K lead free specification for SMT components PS-LF-001.

How To Order

The Build-A Switch concept allows you to mix and match options to create the switch you need. Below is a complete listing of options shown in catalog. To order, simply select desired option from each category and place in the appropriate box.

NOTE: Some of the configurations may not be available or could require some development.

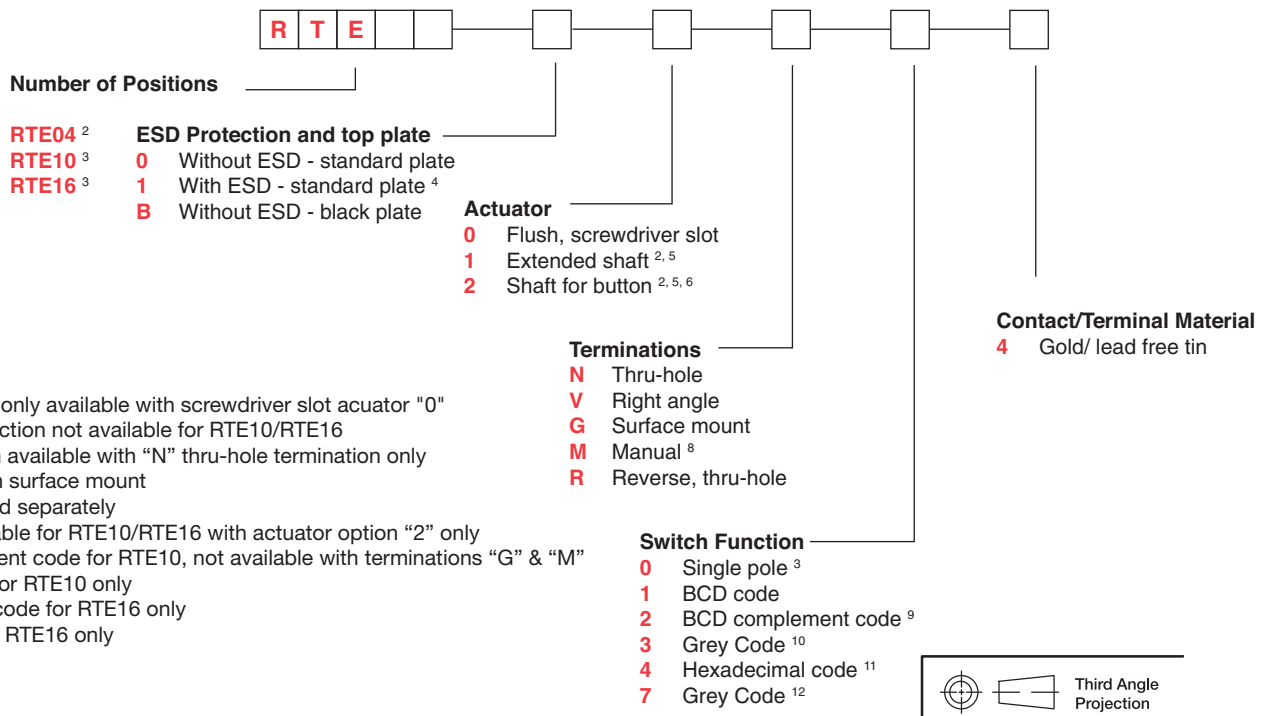

2 - RTE04 version only available with screwdriver slot acuator "0"
3 - Single pole function not available for RTE10/RTE16
4 - ESD protection available with "N" thru-hole termination only
5 - Not available in surface mount
6 - Buttons ordered separately
8 - Manual - available for RTE10/RTE16 with actuator option "2" only
9 - BCD complement code for RTE10, not available with terminations "G" & "M"
10 - Grey Code - for RTE10 only
11 - Hexidecimal code for RTE16 only
12 - Grey code for RTE16 only



RTE Series Low Profile Rotary DIP Switches

SWITCHES WITH STANDARD OPTIONS

PC Mount-Terminal Option N



| PART NUMBER WITHOUT ESD PIN | WITH ESD PIN | NO. POS. | FUNCTION | QTY PER TUBE |
|-----------------------------|-------------------|----------|-------------|--------------|
| RTE0400N04 | RTE0410N04 | 4 | SP4T | 65 |
| RTE1000N14 | RTE1010N14 | 10 | BCD | 65 |
| RTE1600N44 | RTE1610N44 | 16 | HEXADECIMAL | 65 |

Right Angle Mount-Terminal Option V

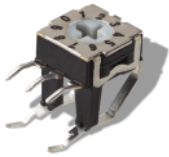

| PART NUMBER | NO. POS. | FUNCTION | QUANTITY |
|-------------------|----------|-------------|-------------|
| RTE0400V04 | 4 | SP4T | 150 per box |
| RTE1000V14 | 10 | BCD | 150 per box |
| RTE1600V44 | 16 | HEXADECIMAL | 150 per box |

Surface Mount-Terminal Option G

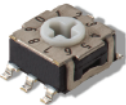

| PART NUMBER | NO. POS. | FUNCTION | QUANTITY PER REEL |
|-------------------|----------|-------------|-------------------|
| RTE0400G04 | 04 | SP4T | 1250 |
| RTE1000G14 | 10 | BCD | 1250 |
| RTE1600G44 | 16 | HEXADECIMAL | 1250 |

NUMBER OF POSITIONS

RTE04 4 POSITION

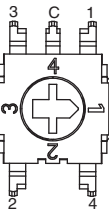

RTE10 10 POSITION

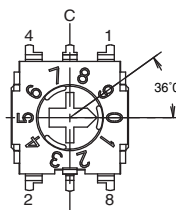

RTE16 16 POSITION

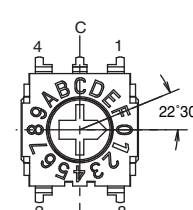

RTE Series Low Profile Rotary DIP Switches

ESD PROTECTION 



H
DIP

0 WITHOUT

1 WITH

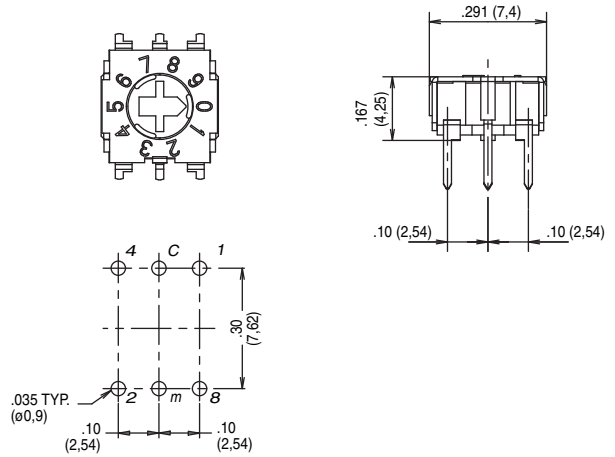
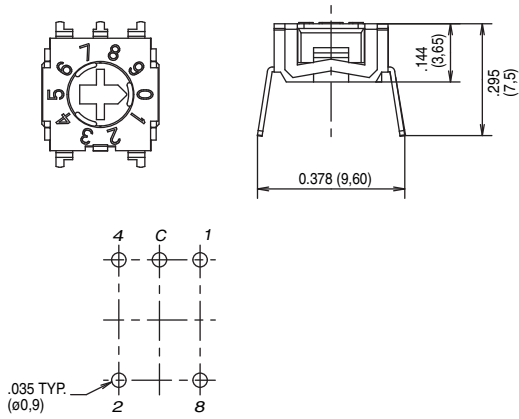

ACTUATOR 

0 FLUSH, SCREWDRIVER SLOT

1 EXTENDED SHAFT
(not available in surface mount)

2 SHAFT FOR BUTTON

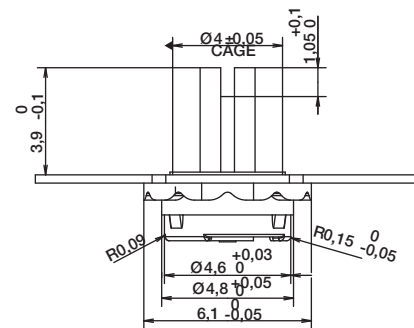
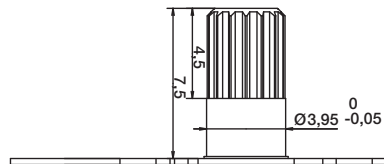
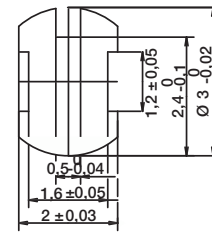
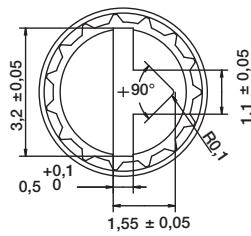
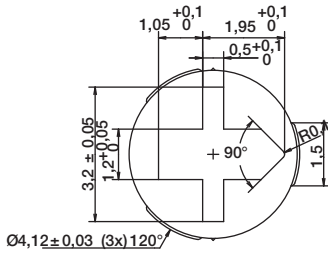

Dimensions are shown: Inch (mm)
Specifications and dimensions subject to change



RTE Series Low Profile Rotary DIP Switches

TERMINATIONS



DIP H

N THRU-HOLE

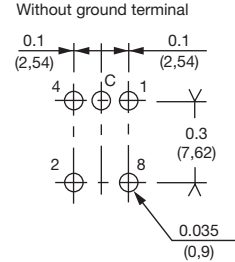
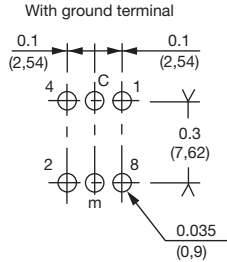
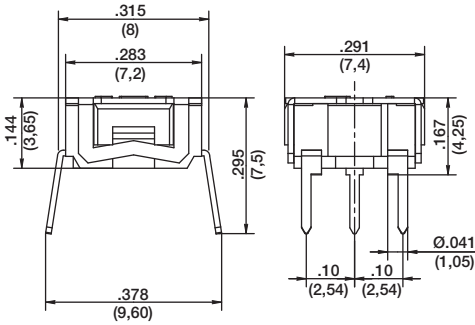

R REVERSE, THRU-HOLE

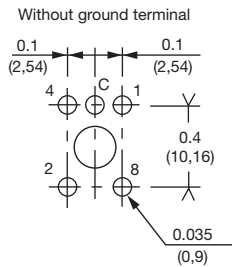
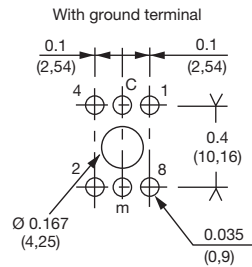
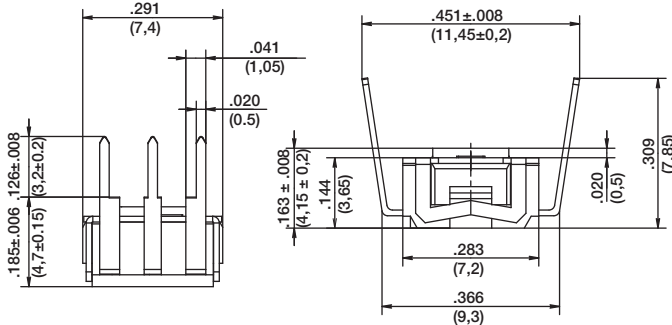

V RIGHT ANGLE, THRU-HOLE

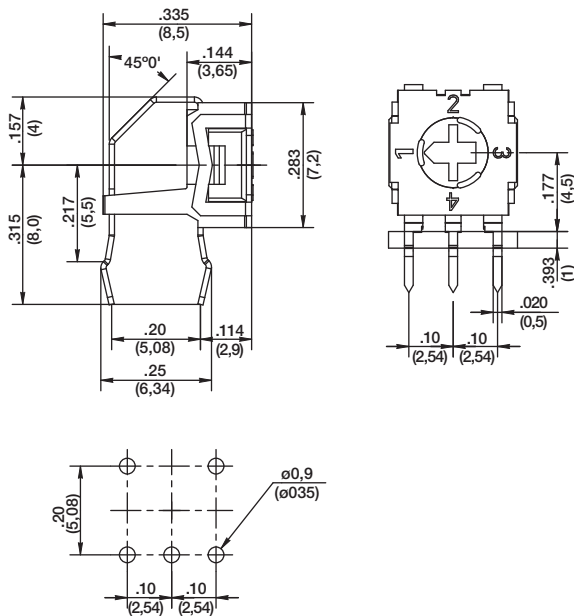

G SURFACE MOUNT

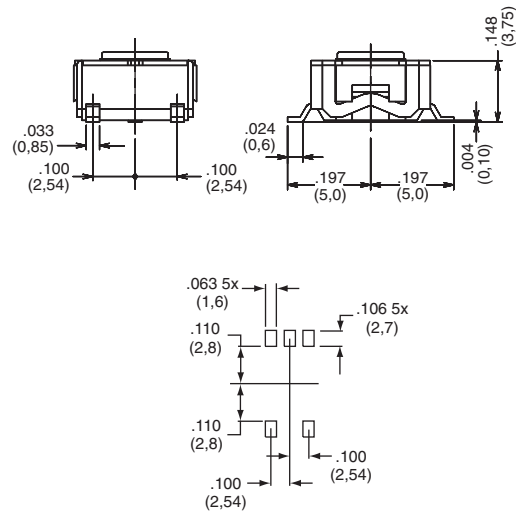

PCB layout seen component side

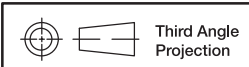

Third Angle
Projection



Dimensions are shown: Inch (mm)
Specifications and dimensions subject to change

RTE Series Low Profile Rotary DIP Switches

TERMINATIONS

M OPTION

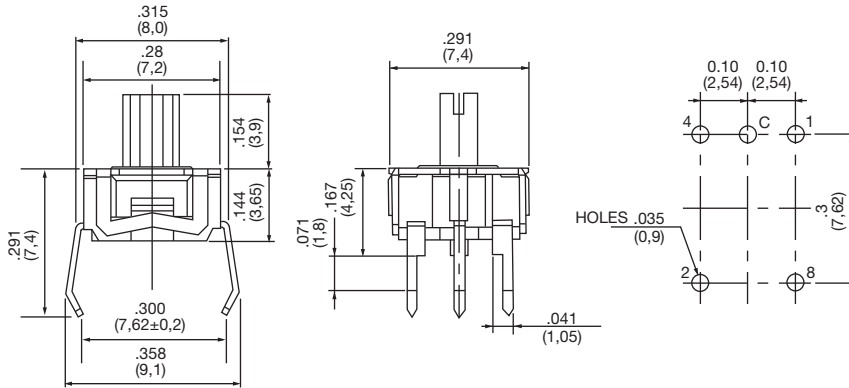

H

DIP

SWITCH FUNCTION

0 SINGLE POLE

| POS. | 1 | 2 | 3 | 4 |
|------|---|---|---|---|
| C | ● | ● | ● | ● |
| 1 | ● | | | |
| 2 | | ● | | |
| 3 | | | ● | |
| 4 | | | | ● |

1 BCD CODE

| POS. | 0 | 1 | 2 | 3 | 4 | 5 | 6 | 7 | 8 | 9 |
|------|---|---|---|---|---|---|---|---|---|---|
| C | ● | ● | ● | ● | ● | ● | ● | ● | ● | ● |
| 1 | | ● | | | | ● | | | | ● |
| 2 | | | ● | | | | ● | | | |
| 4 | | | | ● | ● | ● | | | | |
| 8 | | | | | | | | ● | ● | |

2 BCD COMPLEMENT CODE

| POS. | 0 | 1 | 2 | 3 | 4 | 5 | 6 | 7 | 8 | 9 |
|------|---|---|---|---|---|---|---|---|---|---|
| C | ● | ● | ● | ● | ● | ● | ● | ● | ● | ● |
| 1 | ● | | | | ● | | | ● | | ● |
| 2 | ● | ● | | | | ● | | | | ● |
| 4 | ● | ● | ● | | | | | | | ● |
| 8 | ● | ● | ● | ● | | | | | | |

Other codes available by request.

3 GREY CODE (for RTE10 only)

| POS. | 0 | 1 | 2 | 3 | 4 | 5 | 6 | 7 | 8 | 9 |
|------|---|---|---|---|---|---|---|---|---|---|
| C | ● | ● | ● | ● | ● | ● | ● | ● | ● | ● |
| 1 | | ● | ● | | | ● | | | | ● |
| 2 | | | ● | ● | ● | | | | | |
| 4 | | | | ● | ● | ● | ● | | | |
| 8 | | | | | | | | ● | ● | |

4 HEXADECIMAL CODE

| POS. | 0 | 1 | 2 | 3 | 4 | 5 | 6 | 7 | 8 | 9 | 10 | 11 | 12 | 13 | 14 | 15 |
|------|---|---|---|---|---|---|---|---|---|---|----|----|----|----|----|----|
| C | ● | ● | ● | ● | ● | ● | ● | ● | ● | ● | ● | ● | ● | ● | ● | ● |
| 1 | | ● | | ● | | ● | | ● | | ● | | ● | | ● | | ● |
| 2 | | | ● | ● | | | ● | | | | ● | | ● | | | ● |
| 4 | | | | ● | ● | ● | | | | | ● | ● | ● | | | ● |
| 8 | | | | | | | | ● | ● | ● | ● | ● | ● | ● | ● | ● |

7 GREY CODE (for RTE04 only)

| POS. | 1 | 2 | 3 | 4 |
|------|---|---|---|---|
| C | ● | ● | ● | ● |
| 1 | ● | | | |
| 2 | | ● | | |
| 4 | | | ● | |
| 8 | | | | ● |

(for RTE16 only)

| POS. | 0 | 1 | 2 | 3 | 4 | 5 | 6 | 7 | 8 | 9 | A | B | C | D | E | F |
|------|---|---|---|---|---|---|---|---|---|---|---|---|---|---|---|---|
| C | ● | ● | ● | ● | ● | ● | ● | ● | ● | ● | ● | ● | ● | ● | ● | ● |
| 1 | | ● | | | | ● | | | | ● | | | ● | | ● | |
| 2 | | | ● | ● | | | ● | | | | ● | | ● | | | ● |
| 4 | | | | ● | ● | ● | | | | | ● | ● | ● | | | ● |
| 8 | | | | | | | | ● | ● | ● | ● | ● | ● | ● | ● | ● |

CONTACT MATERIAL

| OPTION CODE | RoHS COMPLIANT | RoHS COMPATIBLE | CONTACT MATERIAL | TERMINAL PLATING |
|-------------|----------------|-----------------|------------------|------------------|
| 4 | YES | YES | GOLD | LEAD FREE TIN |

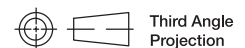

Third Angle Projection



Dimensions are shown: Inch (mm)
Specifications and dimensions subject to change

RTE Series Low Profile Rotary DIP Switches

BUTTONS AVAILABLE

Buttons are ordered separately, shipped in bulk.

DIP H

| Part Number | Color |
|-------------------|-------|
| BTN RTE 40 | Red |
| BTN RTE 50 | Green |
| BTN RTE 90 | Black |

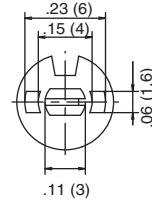
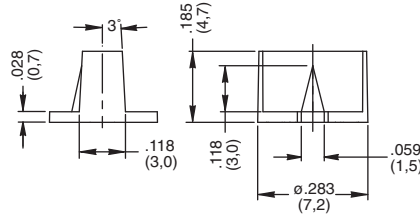
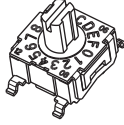

TAPE AND REEL

Tape and reel for RTExx02Gxx
750 pieces per reel.

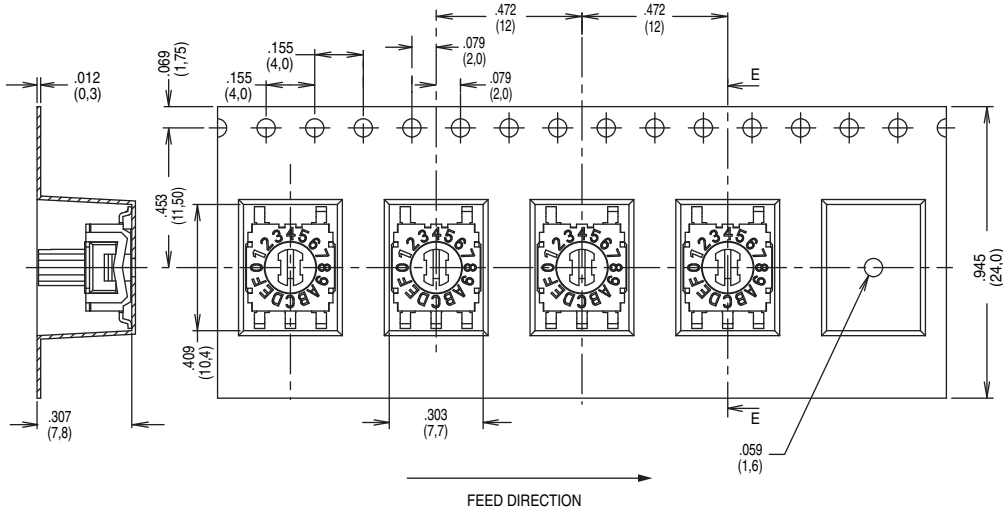

Tape and reel for RTExx00Gxx
1,250 pieces per reel.

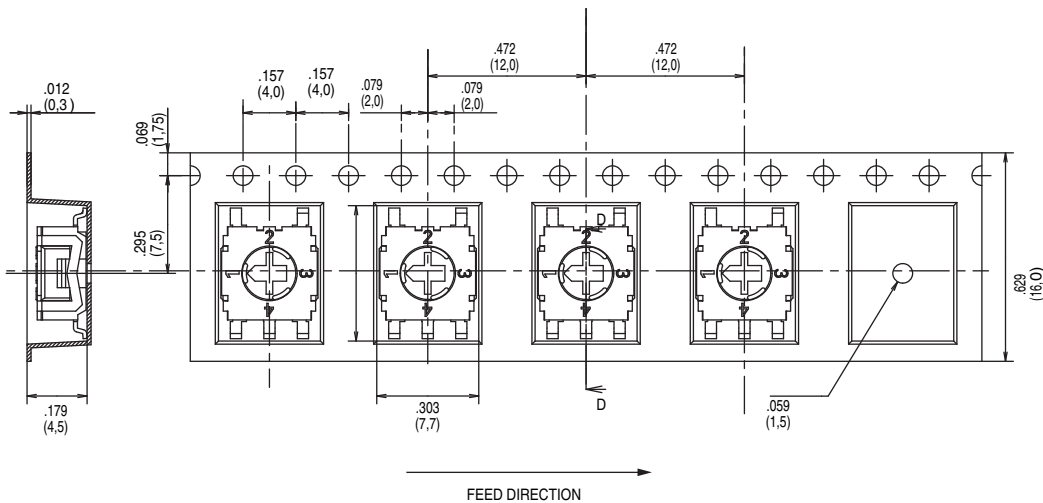

Dimensions are shown: Inch (mm)
Specifications and dimensions subject to change



CD Series 8mm DIP Coded Rotary Switches



Features/Benefits

- Process sealed – withstands soldering and cleaning
- Thru-hole and surface mount models
- Compact size saves space – 36% smaller than traditional 10mm DIP
- Crisp, positive detent ensures actuation
- RoHS compliant

Typical Applications

- Address switching applications
- Data storage devices
- Computer and peripherals
- Instrumentation

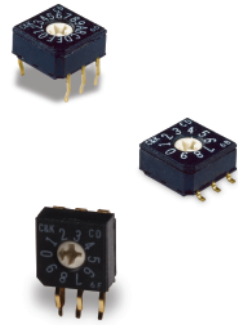

Specifications

CONTACT RATING: 0.4 VA max. @ 20 V AC or V DC max.

MECHANICAL AND ELECTRICAL LIFE:

CD10 & CD16: 20,000 actuations.

CD08: 12,000 actuations.

CONTACT RESISTANCE: 50 milliohms max. initial.

INSULATION RESISTANCE: 100 megohms min.

@ 250 V AC min.

DIELECTRIC STRENGTH: 250 V RMS min. @ sea level.

OPERATING TEMPERATURE: -25°C to 85°C.

STORAGE TEMPERATURE: -40°C to 85°C.

SOLDERABILITY: Per MIL-STD-202F method 208D or EIA RS-186E, method 9 (1 hour steam aging).

PACKAGING: Switches supplied in rigid tubes in full-tube quantities only: this may affect order quantity. Tube quantity is 60 pieces per tube. Surface mount switches available in tape & reel packaging per EIA 481A, 800 per reel, surface mount with “M0” actuator only.

Materials

COVER: PPS (UL94V-0), Color; Black.

BASE: PPS (UL94V-0), Color; Black

ACTUATOR: LCP (UL 94V-0), Color White (CDXXR)
Color Black (CDXXC)

Note: internal o-ring seal standard with all actuators.

MOVABLE CONTACTS: Copper alloy with gold plate over nickel plate.

STATIONARY CONTACTS: Copper alloy with gold plate over nickel plate.

TERMINALS: Copper alloy with gold plate over nickel plate.

Note: Specifications and materials listed above are for switches with standard options. For information on specific and custom switches, consult Customer Service Center.

How To Order

The Build-A Switch concept allows you to mix and match options to create the switch you need. Below is a complete listing of options shown in catalog. To order, simply select desired option from each category and place in the appropriate box.

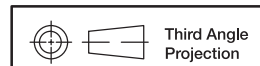
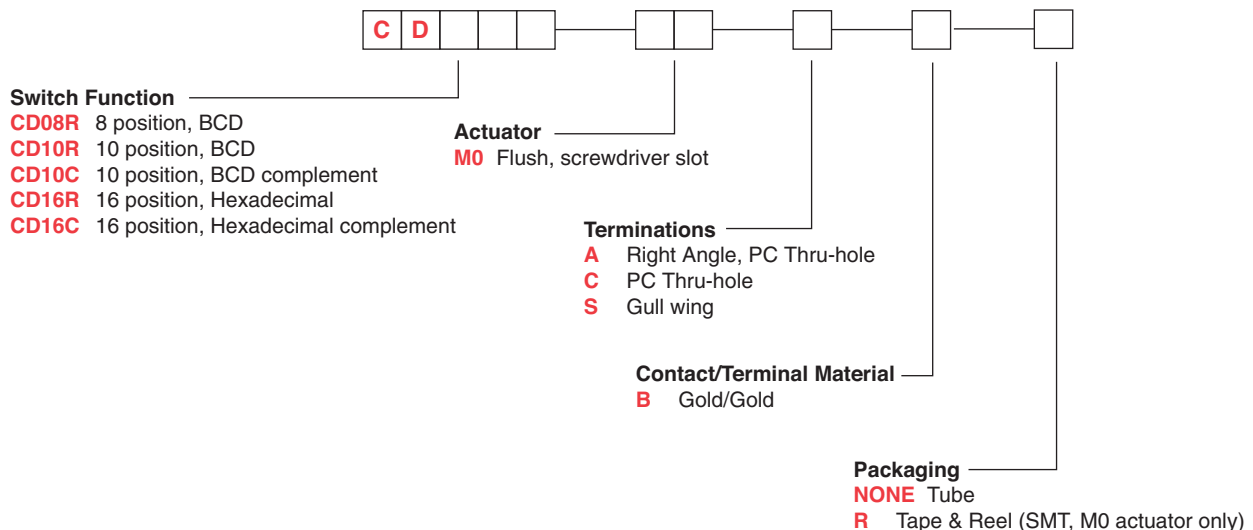

Dimensions are shown: Inch (mm)
Specifications and dimensions subject to change



CD Series 8mm DIP Coded Rotary Switches

SWITCHES WITH STANDARD OPTIONS

PC Mount



CD16RM0CB

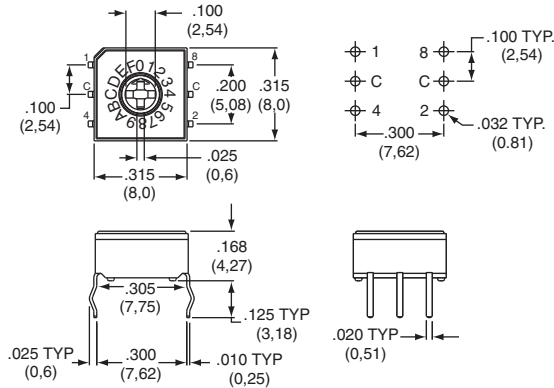

| PART NUMBER | NO. POS. | QUANTITY PER TUBE |
|------------------|----------|-------------------|
| CD08RM0CB | 8 | 60 |
| CD10RM0CB | 10 | 60 |
| CD10CM0CB | 10 | 60 |
| CD16RM0CB | 16 | 60 |
| CD16CM0CB | 16 | 60 |

Right Angle Mount



CD10RM0AB

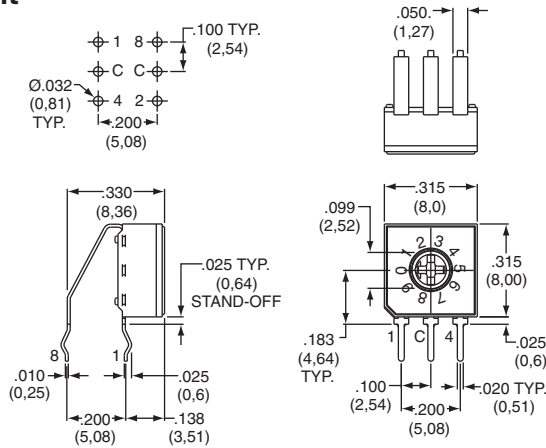

| PART NUMBER | NO. POS. | QUANTITY PER TUBE |
|------------------|----------|-------------------|
| CD08RM0AB | 8 | 60 |
| CD10RM0AB | 10 | 60 |
| CD10CM0AB | 10 | 60 |
| CD16RM0AB | 16 | 60 |
| CD16CM0AB | 16 | 60 |

Surface Mount



CD10RM0SB

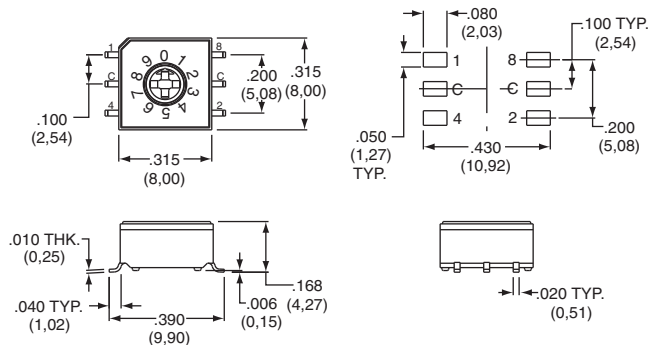

| PART NUMBER | NO. POS. | QUANTITY PER TUBE |
|------------------|----------|-------------------|
| CD08RM0SB | 8 | 60 |
| CD10RM0SB | 10 | 60 |
| CD10CM0SB | 10 | 60 |
| CD16RM0SB | 16 | 60 |
| CD16CM0SB | 16 | 60 |

Note: For tape and reel packaging, add 'R' to end of part number.

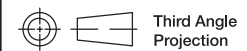

Third Angle
Projection

CD Series 8mm DIP Coded Rotary Switches



H
DIP

SWITCH FUNCTION

CD08R 8 POSITION, BCD
ACTUATOR COLOR: WHITE

| POS. | 0 | 1 | 2 | 3 | 4 | 5 | 6 | 7 |
|------|---|---|---|---|---|---|---|---|
| C | ● | ● | ● | ● | ● | ● | ● | ● |
| 1 | | ● | ● | | ● | ● | | ● |
| 2 | | | ● | ● | | | ● | ● |
| 4 | | | | | ● | ● | ● | ● |
| 8 | | | | | | | | |

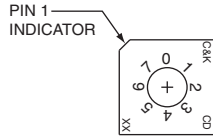

Switches ship and to be solder processed in position "0"

CD10R 10 POSITION, BCD
ACTUATOR COLOR: WHITE

| POS. | 0 | 1 | 2 | 3 | 4 | 5 | 6 | 7 | 8 | 9 |
|------|---|---|---|---|---|---|---|---|---|---|
| C | ● | ● | ● | ● | ● | ● | ● | ● | ● | ● |
| 1 | | ● | ● | | ● | ● | | ● | ● | |
| 2 | | | ● | ● | | | ● | ● | | |
| 4 | | | | | ● | ● | ● | ● | | |
| 8 | | | | | | | | | ● | ● |

Switches ship and to be solder processed in position "0"

CD10C 10 POSITION, BCD COMPLEMENT
ACTUATOR COLOR: BLACK

| POS. | 0 | 1 | 2 | 3 | 4 | 5 | 6 | 7 | 8 | 9 |
|------|---|---|---|---|---|---|---|---|---|---|
| C | ● | ● | ● | ● | ● | ● | ● | ● | ● | ● |
| 1 | ● | | ● | | ● | | ● | | ● | |
| 2 | ● | | | ● | | ● | | ● | | ● |
| 4 | ● | ● | ● | ● | | | | | ● | ● |
| 8 | ● | ● | ● | ● | ● | ● | ● | ● | ● | ● |

Switches ship and to be solder processed in position "7"

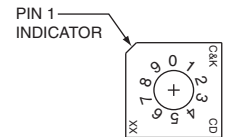

CD16R 16 POSITION, HEXADECIMAL
ACTUATOR COLOR: WHITE

| POS. | 0 | 1 | 2 | 3 | 4 | 5 | 6 | 7 | 8 | 9 | A | B | C | D | E | F | |
|------|---|---|---|---|---|---|---|---|---|---|---|---|---|---|---|---|---|
| C | ● | ● | ● | ● | ● | ● | ● | ● | ● | ● | ● | ● | ● | ● | ● | ● | ● |
| 1 | | ● | | ● | | ● | | ● | | ● | | ● | | ● | | ● | |
| 2 | | | ● | ● | | | ● | ● | | | ● | ● | | | ● | ● | |
| 4 | | | | | ● | ● | ● | ● | | | | | ● | ● | ● | ● | |
| 8 | | | | | | | | | ● | ● | ● | ● | ● | ● | ● | ● | |

Switches ship and to be solder processed in position "0"

CD16C 16 POSITION, HEXADECIMAL COMPLEMENT
ACTUATOR COLOR: BLACK

| POS. | 0 | 1 | 2 | 3 | 4 | 5 | 6 | 7 | 8 | 9 | A | B | C | D | E | F | |
|------|---|---|---|---|---|---|---|---|---|---|---|---|---|---|---|---|---|
| C | ● | ● | ● | ● | ● | ● | ● | ● | ● | ● | ● | ● | ● | ● | ● | ● | ● |
| 1 | ● | | ● | | ● | | ● | | ● | | ● | | ● | | ● | | |
| 2 | ● | | | ● | | ● | | ● | | ● | | ● | | ● | | ● | |
| 4 | ● | ● | ● | ● | | | | | | | ● | ● | ● | ● | | | |
| 8 | ● | ● | ● | ● | ● | ● | ● | ● | ● | ● | ● | ● | ● | ● | ● | ● | |

Switches ship and to be solder processed in position "F"

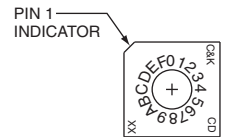

ACTUATOR

M0 (STD.) FLUSH WITH SCREWDRIVER SLOT

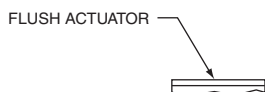
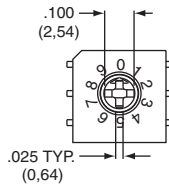

NOTE: Designed for #0 Phillips screwdriver.



Dimensions are shown: Inch (mm)
Specifications and dimensions subject to change



CD Series 8mm DIP Coded Rotary Switches

TERMINATIONS

DIP H

DIP H

C PC, THRU-HOLE

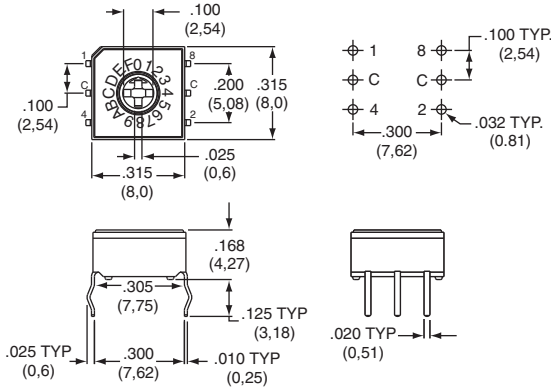

A RIGHT ANGLE, PC THRU-HOLE

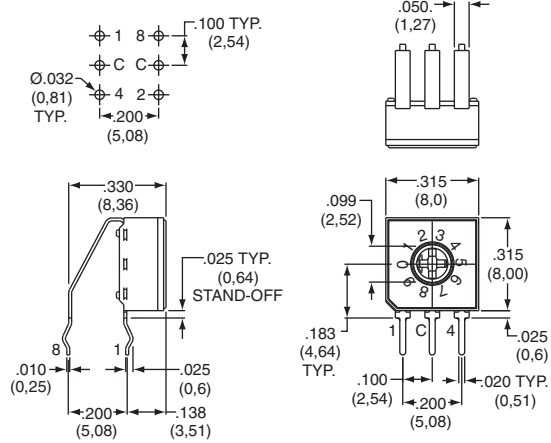

S SURFACE MOUNT

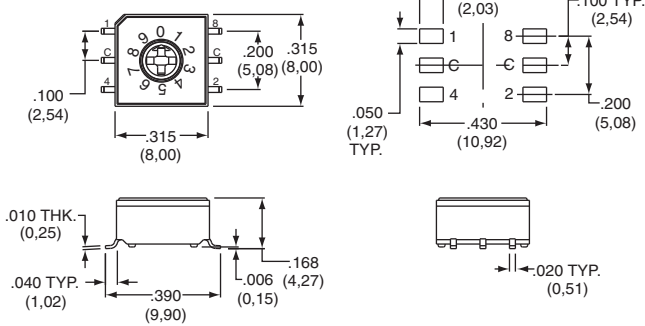

CONTACT MATERIAL

| OPTION CODE | RoHS COMPLIANT* | RoHS COMPATIBLE* | CONTACT MATERIAL | TERMINAL PLATING | RATING | |
|-------------|-----------------|------------------|------------------|------------------|-----------------------|----------------------------------|
| B | YES | YES | GOLD | GOLD | LOW LEVEL/DRY CIRCUIT | 0.4 VC MAX. @ 20 V AC or DC MAX. |

* Note: See Technical Data section of this catalog for RoHS compliant and compatible definitions and specifications.

TAPE & REEL

For part number CDxxM0SB

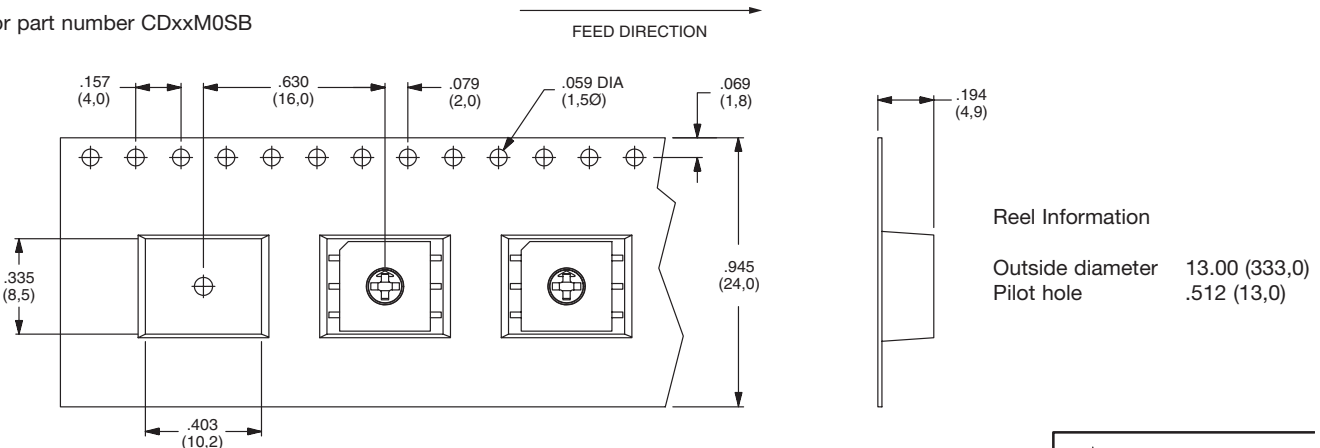

Reel Information

Outside diameter 13.00 (333,0)
Pilot hole .512 (13,0)

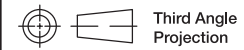

Third Angle Projection

Dimensions are shown: Inch (mm)
Specifications and dimensions subject to change



CRD Series 10mm DIP Coded Rotary Switches



H

DIP

Features/Benefits

- Process sealed – withstands soldering and cleaning
- Thru-hole and surface mount models
- Crisp, positive detent ensures actuation
- Computer and peripherals
- RoHS compliant

Typical Applications

- Address switching applications
- Data storage devices
- Computer and peripherals
- Instrumentation

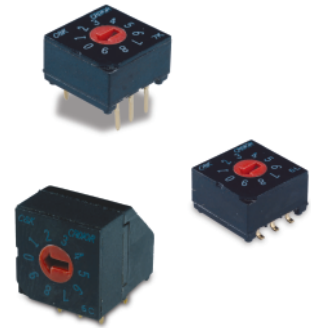

Specifications

CONTACT RATING: 0.4 V AC, DC 20 V max.
 ELECTRICAL LIFE: 20,000 steps min. @ 5 V DC 10 mA.
 MECHANICAL LIFE: 30,000 steps min.
 CONTACT RESISTANCE: 100 milliohms max. initial @ 2 V DC 10 mA.
 INSULATION RESISTANCE: 1000 megohms min. @ 100 V DC
 DIELECTRIC STRENGTH: 300 V AC for 1 minute.
 OPERATING TEMPERATURE: -20°C to 85°C.
 STORAGE TEMPERATURE: -40°C to 85°C.
 OPERATING FORCE: 1000 grams max.
 PACKAGING: Switches supplied in anti-static tubes in full quantities only. This may affect order quantity. Surface mount models with MO actuators available in tape and reel, 500 pieces per reel.

Materials

COVER: PPS (black)
 HOUSING: PPS (black)
 ACTUATOR: PA 6T M0 actuator option; PBT L1 and W1 actuator option.
 CONTACTS: Beryllium Copper with Gold over Nickel plate
 TERMINALS: Brass with Gold Nickel plate.

Note: Specifications and materials listed above are for switches with standard options. For information on specific and custom switches, consult Customer Service Center.

How To Order

The Build-A Switch concept allows you to mix and match options to create the switch you need. Below is a complete listing of options shown in catalog. To order, simply select desired option from each category and place in the appropriate box.

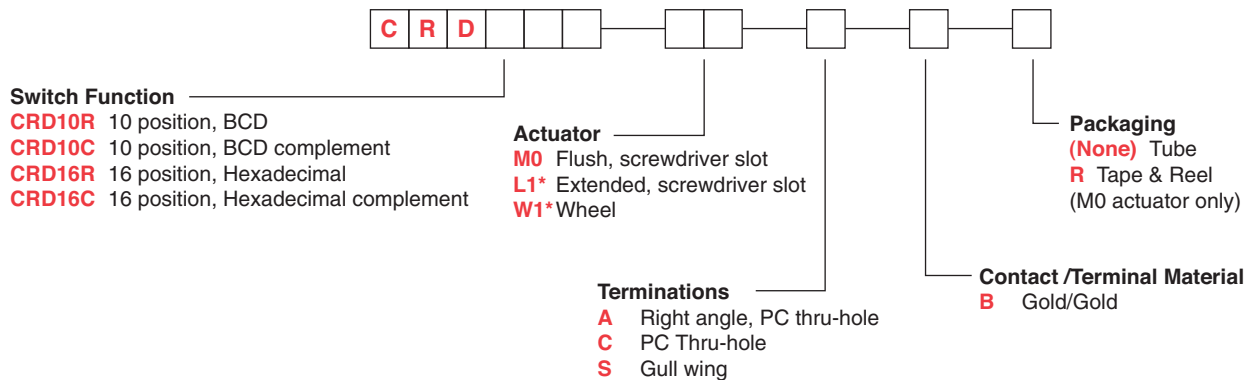

* Note - L1 and W1 actuators are not available in termination "S"

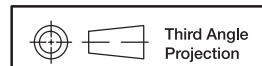

Dimensions are shown: Inch (mm)
 Specifications and dimensions subject to change



CRD Series 10mm DIP Coded Rotary Switches

SWITCHES WITH STANDARD OPTIONS



DIP

PC Mount

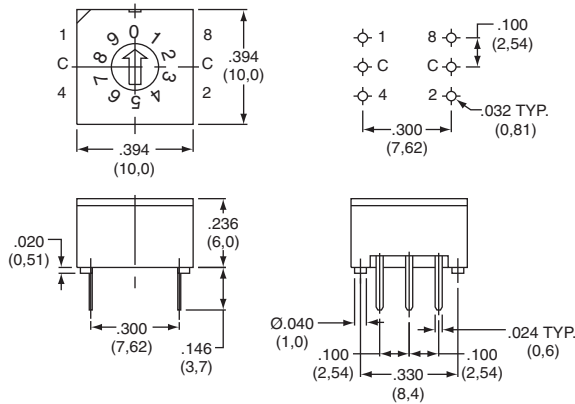
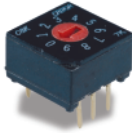

| PART NUMBER | NO. POS. | QUANTITY PER TUBE |
|-------------------|----------|-------------------|
| CRD10RM0CB | 10 | 45 |
| CRD16RM0CB | 16 | 45 |

Right Angle Mount

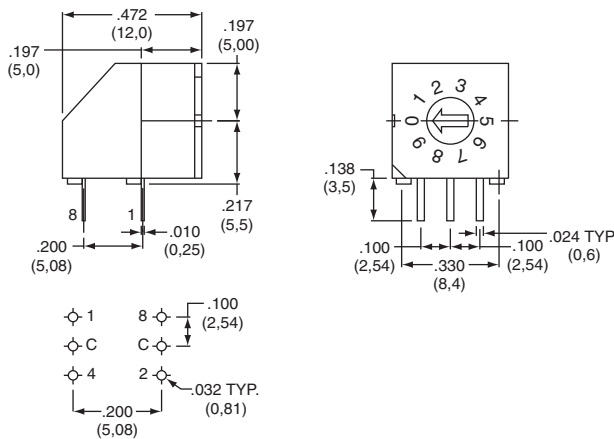

| PART NUMBER | NO. POS. | QUANTITY PER TUBE |
|-------------------|----------|-------------------|
| CRD10RM0AB | 10 | 45 |
| CRD16RM0AB | 16 | 45 |

Surface Mount

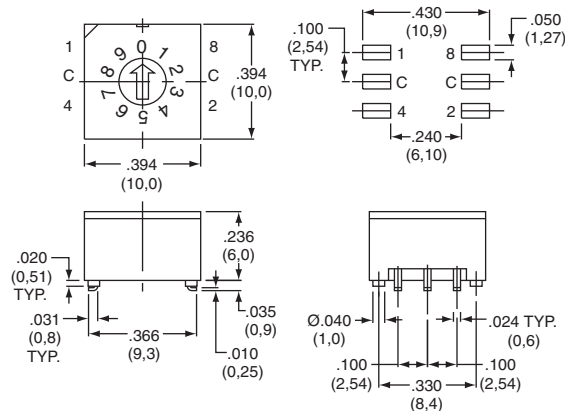

| PART NUMBER | NO. POS. | QUANTITY PER TUBE |
|-------------------|----------|-------------------|
| CRD10RM0SB | 10 | 45 |
| CRD16RM0SB | 16 | 45 |



Dimensions are shown: Inch (mm)
Specifications and dimensions subject to change



CRD Series 10mm DIP Coded Rotary Switches



H
DIP

SWITCH FUNCTION

CRD10R

10 POSITION, BCD
ACTUATOR COLOR: RED

| POS. | 0 | 1 | 2 | 3 | 4 | 5 | 6 | 7 | 8 | 9 |
|------|---|---|---|---|---|---|---|---|---|---|
| C | ● | ● | ● | ● | ● | ● | ● | ● | ● | ● |
| 1 | | ● | | ● | | ● | | ● | | ● |
| 2 | | | ● | | ● | | ● | | ● | |
| 4 | | | | ● | | ● | | ● | | ● |
| 8 | | | | | ● | | ● | | ● | ● |

Switches ship and to be solder processed in position "0"

CRD10C

10 POSITION, BCD COMPLEMENT
ACTUATOR COLOR: ORANGE

| POS. | 0 | 1 | 2 | 3 | 4 | 5 | 6 | 7 | 8 | 9 |
|------|---|---|---|---|---|---|---|---|---|---|
| C | ● | ● | ● | ● | ● | ● | ● | ● | ● | ● |
| 1 | ● | | | | | | | | | |
| 2 | ● | ● | | | | | | | | |
| 4 | ● | ● | ● | | | | | | | |
| 8 | ● | ● | ● | ● | | | | | | |

Switches ship and to be solder processed in position "7"

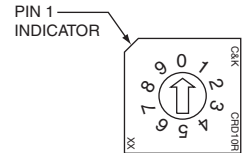

CRD16R

16 POSITION, HEXADECIMAL
ACTUATOR COLOR: BLACK

| POS. | 0 | 1 | 2 | 3 | 4 | 5 | 6 | 7 | 8 | 9 | A | B | C | D | E | F |
|------|---|---|---|---|---|---|---|---|---|---|---|---|---|---|---|---|
| C | ● | ● | ● | ● | ● | ● | ● | ● | ● | ● | ● | ● | ● | ● | ● | ● |
| 1 | | ● | | | | | | | | | | | | | | |
| 2 | | | ● | | ● | | ● | | ● | | ● | | ● | | ● | |
| 4 | | | | ● | | ● | | ● | | ● | | ● | | ● | | ● |
| 8 | | | | | ● | | ● | | ● | | ● | | ● | | ● | ● |

Switches ship and to be solder processed in position "0"

CRD16C

16 POSITION, HEXADECIMAL COMPLEMENT
ACTUATOR COLOR: WHITE

| POS. | 0 | 1 | 2 | 3 | 4 | 5 | 6 | 7 | 8 | 9 | A | B | C | D | E | F |
|------|---|---|---|---|---|---|---|---|---|---|---|---|---|---|---|---|
| C | ● | ● | ● | ● | ● | ● | ● | ● | ● | ● | ● | ● | ● | ● | ● | ● |
| 1 | ● | | | | | | | | | | | | | | | |
| 2 | ● | ● | | | | | | | | | | | | | | |
| 4 | ● | ● | ● | | | | | | | | | | | | | |
| 8 | ● | ● | ● | ● | | | | | | | | | | | | |

Switches ship and to be solder processed in position "F"

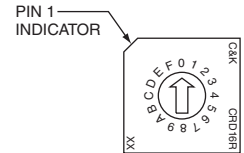

ACTUATOR

(STD.) FLUSH WITH SCREWDRIVER SLOT

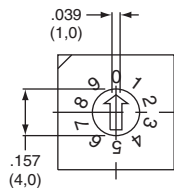

FLUSH ACTUATOR



L1*

EXTENDED WITH SCREWDRIVER SLOT

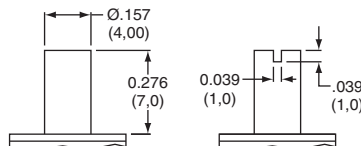
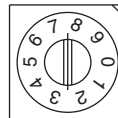

W1*

WHEEL

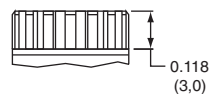

NOTE: Designed for #0 Phillips screwdriver.

* L1 and W1 actuators are not available in termination "S"



Third Angle Projection

Dimensions are shown: Inch (mm)
Specifications and dimensions subject to change



CRD Series 10mm DIP Coded Rotary Switches

TERMINATIONS



C PC, THRU-HOLE

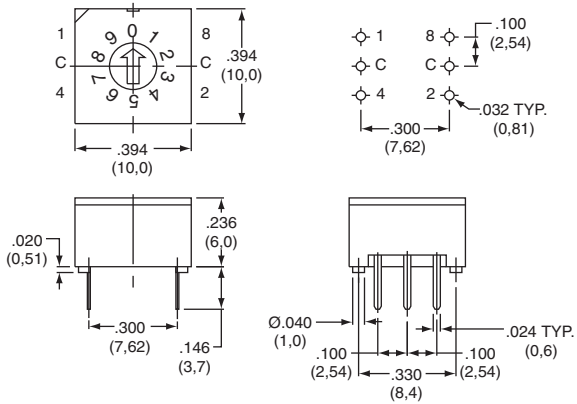

A RIGHT ANGLE, PC THRU-HOLE

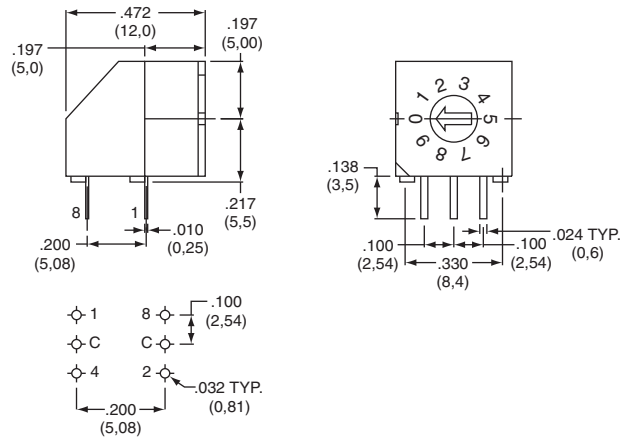

S SURFACE MOUNT

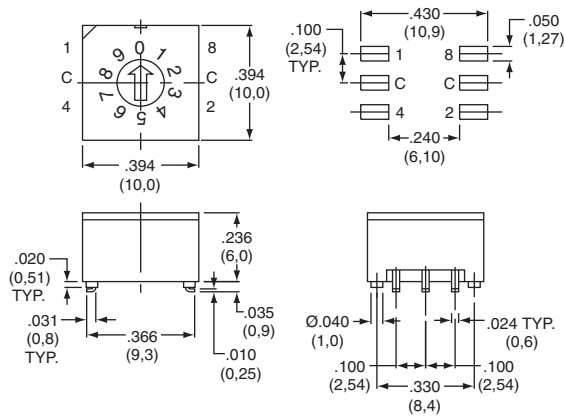

M0

CONTACT MATERIAL



| OPTION CODE | RoHS COMPLIANT* | RoHS COMPATIBLE* | CONTACT MATERIAL | TERMINAL PLATING | RATING | |
|-------------|-----------------|------------------|------------------|------------------|-----------------------|----------------------------------|
| B | YES | YES | GOLD | GOLD | LOW LEVEL/DRY CIRCUIT | 0.4 VC MAX. @ 20 V AC or DC MAX. |

* Note: See Technical Data section of this catalog for RoHS compliant and compatible definitions and specifications.

TAPE & REEL

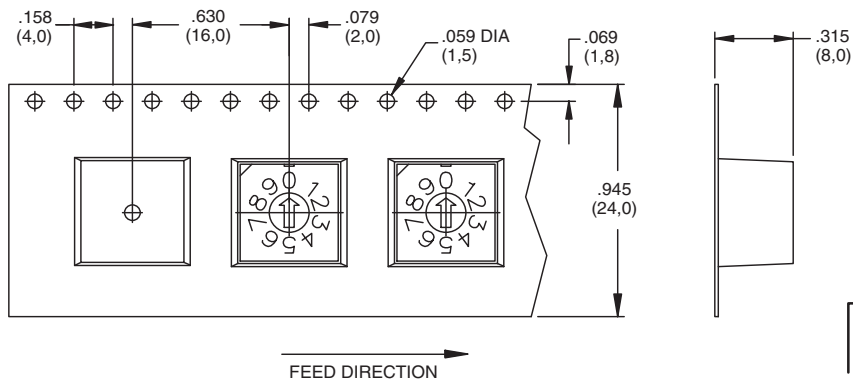







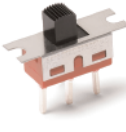

Third Angle
Projection

Dimensions are shown: Inch (mm)
Specifications and dimensions subject to change

Slides

Product Selection Guide

| Slide |  |  |  |  |  |  |  |  |
|---------------------|---|---|---|---|--|---|---|---|
| Series | ES | TS | 1000 | GS | L | LP | S | V |
| Switch Type | Tiny | Tiny | Miniature | Ultra-miniature | Miniature | Miniature | Power | Power & Line Voltage |
| Poles | 1 & 2 | 1 | 1 & 2 | 1 | 1 & 2 | 1 & 2 | 1 & 2 | 1 & 2 |
| Momentary | | | • | | • | | • | |
| Process Sealed | • | | | • | | | | |
| Splashproof | • | | | | • | | | |
| Screwdriver Slot | | | | | • | | • | • |
| Housing Marking | | | | | | • | • | |
| Tape & Reel | • | | | • | | | | |
| Max. Current | 0.4 VA | 3 A | 6 A | 0.4 VA | 4 A | 11 A | 15 A | 10.1 A |
| Terminations | | | | | | | | |
| Wire Wrap | | • | • | | • | | | |
| Quick Connect | | | • | | | | • | • |
| Wire Lead | | | | | • | • | • | |
| Solder Lug | | | • | | • | • | • | |
| PC | • | • | • | • | • | | • | • |
| PCB Mount Options | | | | | | | | |
| Thru-hole | • | • | • | • | • | • | • | • |
| Vertical | • | • | • | • | • | • | • | • |
| Right Angle | • | • | • | • | | | • | • |
| Surface Mount | • | | | • | | | | |
| Panel Mount Options | | | | | | | | |
| Snap-in | | | | | | • | • | • |
| Mounting Ears | | | • | | • | | • | • |
| Right Angle | • | • | • | • | | | • | • |
| Page No. | I-4 | I-8 | I-11 | I-17 | I-19 | I-25 | I-28 | I-33 |

Slides Product Selection Guide

| Slide |  |  |  |  |  |  |  |  |
|---------------------|---|---|---|---|--|---|---|---|
| Series | OS | PCM | AYZ | JS | JSM | JSX | SK | SS |
| Switch Type | Miniature | Low Profile | Low Profile | Low Profile | Low Profile | Low Profile | Miniature | Miniature |
| Poles | 1 & 2 | 1 & 2 | 1 & 2 | 1 & 2 | 1 | 1 | 1, 2 & 4 | 1, 2 & 4 |
| Momentary | | | | | • | • | | |
| Process Sealed | | | | | | | | |
| Splashproof | | | | | | | | |
| Screwdriver Slot | | | | | | | | |
| Housing Marking | | | | | | | | |
| Tape & Reel | | • | | • | • | • | | |
| Max. Current | 200mA | 0.3A | 100mA | 0.3A | 0.3A | 0.3A | 0.3A | 0.3A |
| Terminations | | | | | | | | |
| Wire Wrap | | | | | | | | |
| Quick Connect | | | | | | | | |
| Wire Lead | | | | | | | | |
| Solder Lug | • | | | | | | | |
| PC | • | • | • | • | | | • | • |
| PCB Mount Options | | | | | | | | |
| Thru-hole | • | | | • | | | • | • |
| Vertical | • | | | • | | | | • |
| Right Angle | • | | | • | | | • | |
| Surface Mount | | • | • | • | • | • | • | • |
| Panel Mount Options | | | | | | | | |
| Snap-in | | | | | | | | |
| Mounting Ears | • | | | | | | | • |
| Right Angle | | | | | | | | |
| Page No. | I-37 | I-44 | I-46 | I-49 | I-55 | I-60 | I-61 | I-91 |

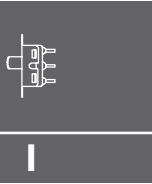

Slide

ES Series Sealed Tiny Slide Switches

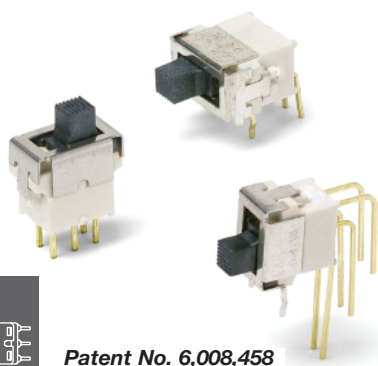

Patent No. 6,008,458

Features/Benefits

- Process compatible—internal o-ring and epoxy base seal
- Thru-hole & surface mount models
- Reliable contact design ensures long electrical life
- Robust actuator for easy actuation
- RoHS compliant

Typical Applications

- Computer peripherals & network products
- Test & measurement equipment
- Telephone & cable modems

Slide

Specifications

CONTACT RATING: 0.4 VA max. @ 20 V AC or DC max.
 MECHANICAL & ELECTRICAL LIFE: 40,000 make-and-break cycles at full load.
 CONTACT RESISTANCE: 50 m Ω max. initial @ 2-4 V DC, 100 mA.
 INSULATION RESISTANCE: 10⁹ Ω min.
 DIELECTRIC STRENGTH: 500 Vrms min.
 OPERATING TEMPERATURE: -30°C to 85°C.
 SOLDERABILITY: Per MIL-STD-202F method 208D, or EIA RS-186E method 9.
 DEGREE OF PROTECTION: IP57; Protection against harmful dust deposit, full-scale voltage protection, temporary immersion.
 ESD ENDURANCE: 8kv min. (EIA 545).
 PACKAGING: Thru-hole switches supplied in anti-static trays. Surface mount switches available in tape and reel packaging.

Materials

HOUSING & BASE: Nylon (UL 94V-0).
 ACTUATOR: LCP (UL 94V-0) black, standard.
 SURFACE PLATE: Stainless steel with tin plate.
 MOVABLE CONTACT: Bronze with gold plate over nickel plate.
 STATIONARY CONTACTS: Copper alloy, with gold plate over nickel plate.
 TERMINALS: Copper alloy, with gold over nickel plate. All terminals insert molded.
 BASE & TERMINAL SEAL: Epoxy.

NOTE: All models RoHS compliant and compatible with all options.

NOTE: Specifications and materials listed above are for switches with standard options. For information on specific and custom switches, consult Customer Service Center.

How To Order

Complete part numbers for ES Series Sealed Tiny Slide Switches are shown on pages I-5 through I-7. These unique tiny slide switches are process compatible. An internal o-ring and epoxy base seal protects the switch from wave and reflow soldering, as well as cleaning processes.

| PART NUMBER | SWITCH FUNCTION | | |
|-----------------|-----------------|--------|--------|
| | POS. 1 | POS. 2 | POS. 3 |
| ES01MCBE | ON | NONE | ON |
| ES03MCBE | ON | OFF | ON |
| CONN. TERMINALS | 2-3 | OPEN | 2-1 |
| SCHEMATIC | | | |
| SPDT | | | |
| ES02MCBE | OFF | NONE | ON |
| CONN. TERMINALS | OPEN | N/A | 3-1 |
| SCHEMATIC | | | |
| SPST | | | |

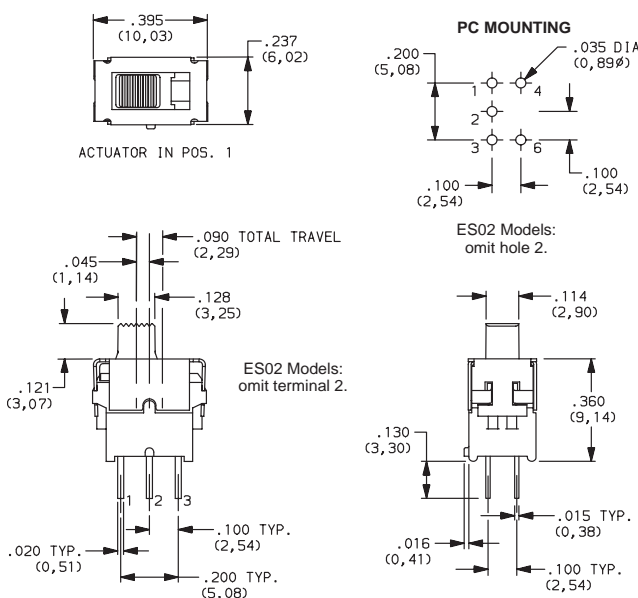

ES01MCBE
SPDT



Dimensions are shown: Inch (mm)
 Specifications and dimensions subject to change



ES Series Sealed Tiny Slide Switches



ES21MCBE
DPDT

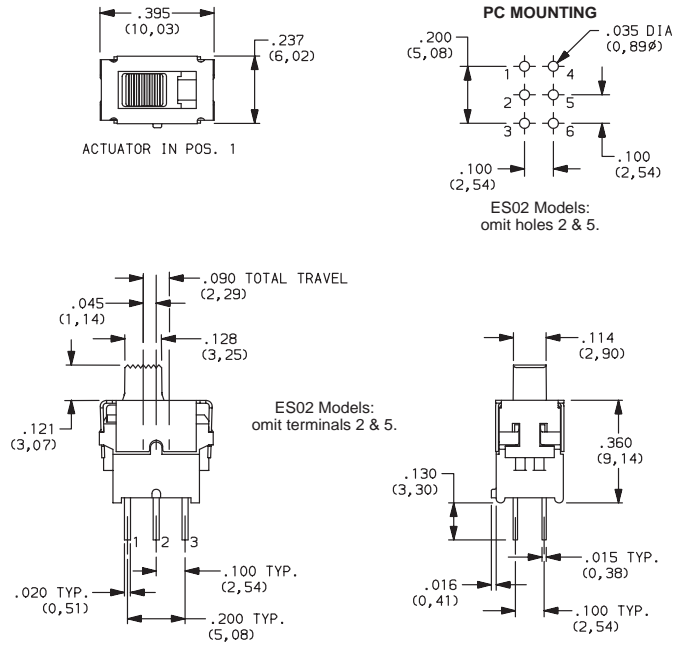

| PART NUMBER | SWITCH FUNCTION | | |
|-----------------|-----------------|--------|----------|
| | POS. 1 | POS. 3 | POS. 2 |
| ES21MCBE | ON | NONE | ON |
| ES23MCBE | ON | OFF | ON |
| CONN. TERMINALS | 2-3, 5-6 | OPEN | 2-1, 5-4 |
| SCHEMATIC | | | |
| | | | |
| DPDT | | | |
| ES22MCBE | OFF | NONE | ON |
| CONN. TERMINALS | OPEN | N/A | 3-1, 6-4 |
| SCHEMATIC | | | |
| | | | |
| DPST | | | |

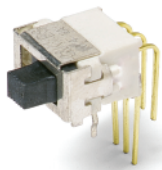

ES21MABE
DPDT

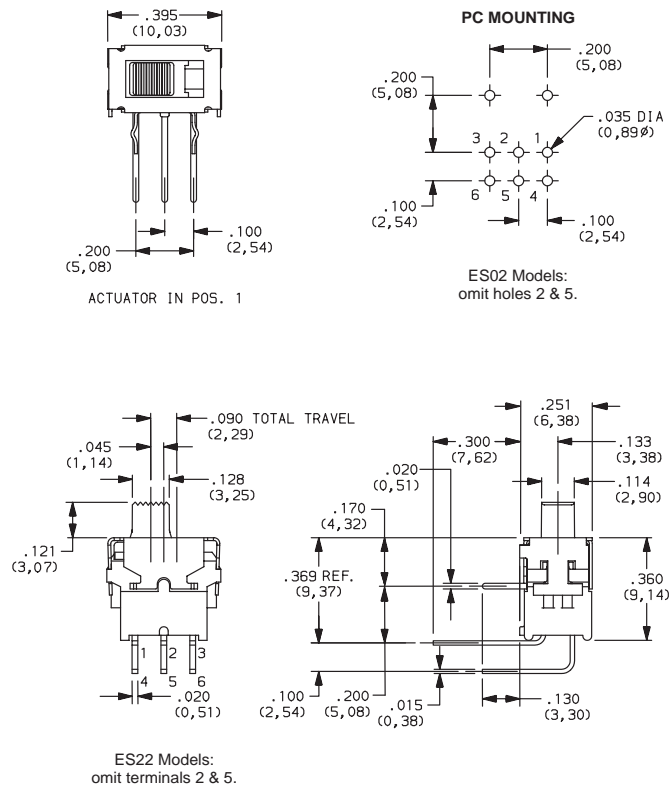

| PART NUMBER | SWITCH FUNCTION | | |
|-----------------|-----------------|--------|----------|
| | POS. 1 | POS. 2 | POS. 3 |
| ES21MABE | ON | NONE | ON |
| ES23MABE | ON | OFF | ON |
| CONN. TERMINALS | 2-3, 5-6 | OPEN | 2-1, 5-4 |
| SCHEMATIC | | | |
| | | | |
| DPDT | | | |
| ES22MABE | OFF | NONE | ON |
| CONN. TERMINALS | OPEN | N/A | 3-1 |
| SCHEMATIC | | | |
| | | | |
| DPST | | | |



Dimensions are shown: Inches (mm)
Specifications and dimensions subject to change

www.ck-components.com

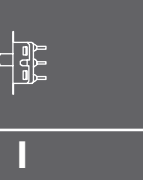

Slide

ES Series Sealed Tiny Slide Switches

Slide

| PART NUMBER | SWITCH FUNCTION | | |
|------------------|-----------------|--------|--------|
| | POS. 1 | POS. 2 | POS. 3 |
| ES01MAVBE | ON | NONE | ON |
| ES03MAVBE | ON | OFF | ON |
| CONN. TERMINALS | 2-3 | OPEN | 2-1 |
| SCHEMATIC | | | |
| | | | |

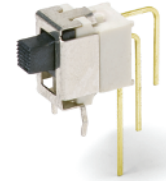
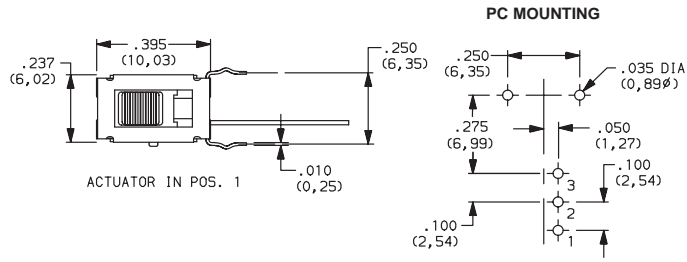

**ES01MAVBE
SPDT**

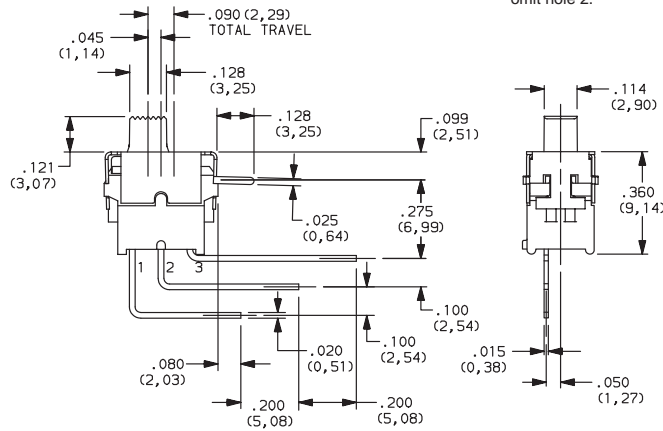

ES02 Models:
omit terminal 2.

| PART NUMBER | SWITCH FUNCTION | | |
|------------------|-----------------|--------|--------|
| | POS. 1 | POS. 2 | POS. 3 |
| ES01MSABE | ON | NONE | ON |
| ES03MSABE | ON | OFF | ON |
| CONN. TERMINALS | 2-3 | OPEN | 2-1 |
| SCHEMATIC | | | |
| | | | |
| SPDT | | | |
| ES02MSABE | OFF | NONE | ON |
| CONN. TERMINALS | OPEN | N/A | 3-1 |
| SCHEMATIC | | | |
| | | | |
| SPST | | | |

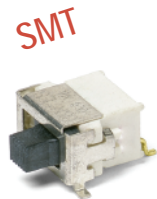
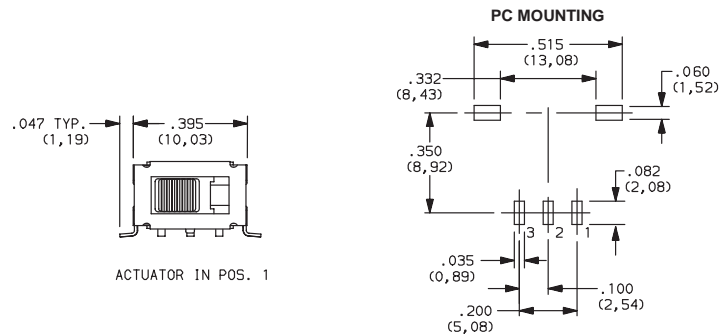

**ES01MSABE
Horizontal Actuation
SPDT**

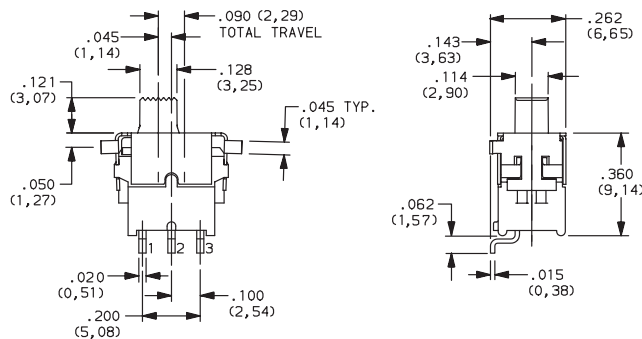

ES02 Models:
omit terminal 2.



Third Angle
Projection
Dimensions are shown: Inch (mm)
Specifications and dimensions subject to change



ES Series Sealed Tiny Slide Switches

TAPE & REEL

For part numbers ESXXMSABE

| REEL INFORMATION | |
|-------------------|---------------|
| OUTSIDE DIAMETER | 13.00 (330,0) |
| PILOT HOLE | .512 (13,0) |
| QUANTITY PER REEL | 300 |

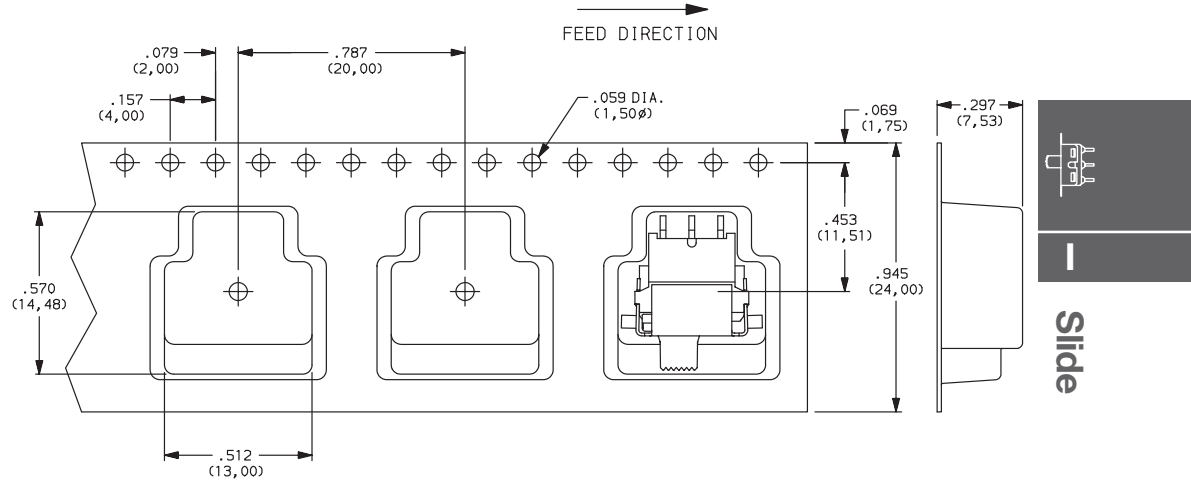

Dimensions are shown: Inches (mm)
Specifications and dimensions subject to change

TS Series Tiny Slide Switches

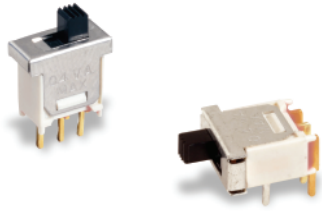

Models Available

Features/Benefits

- **Reliable contact design ensures long electrical life**
- **Ratings up to 3 AMPS**
- **Epoxy terminal-seal compatible with bottom wash cleaning**
- **RoHS compliant**

Typical Applications

- **Test & measurement equipment**
- **Computers & peripherals**
- **Telecommunications & networking equipment**

Specifications

CONTACT RATING: B contact material: 0.4 VA max. @ 20 V AC or DC max. Q contact material (TS01 Model): 3 AMPS @ 120 V AC or 28 V DC; (TS02, TS03 Models): 1 AMP @ 120 V AC or 28 V DC. See page I-10 for additional ratings.

ELECTRICAL LIFE:

TS01 MODELS: 60,000 make-and-break cycles at full load.
TS02, TS03 MODELS: 30,000 cycles.

CONTACT RESISTANCE: Below 20 m Ω typ. initial @ 2-4 V DC, 100 mA, for both silver and gold plated contacts.

INSULATION RESISTANCE: 10⁹ Ω min.

DIELECTRIC STRENGTH: 1,000 Vrms min. @ sea level.

OPERATING TEMPERATURE: -30°C to 85°C

SOLDERABILITY: Per MIL-STD-202F method 208D, or EIA RS-186E method 9 (1 hour steam aging).

Materials

CASE: Glass filled nylon 4/6, flame retardant, heat stabilized.

ACTUATOR: Nylon, black standard.

HOUSING: Stainless steel or stainless steel, nickel plated.

END CONTACTS: B contact material: Copper alloy, with gold plate over nickel plate. Q contact material: Coin silver, silver plated. See page I-10 for additional contact materials.

CENTER CONTACT & ALL TERMINALS: B contact material: Copper alloy, with gold plate over nickel plate. Q contact material: Copper alloy, silver plated. See page I-10 for additional contact materials.

TERMINAL SEAL: Epoxy. Refer to Soldering and Cleaning in Technical Data chapter.

NOTE: Any models supplied with Q, B, G, P, S or R contact material are RoHS compliant.

NOTE: Specifications and materials listed above are for switches with standard options. For information on specific and custom switches, consult Customer Service Center.

Build-A-Switch



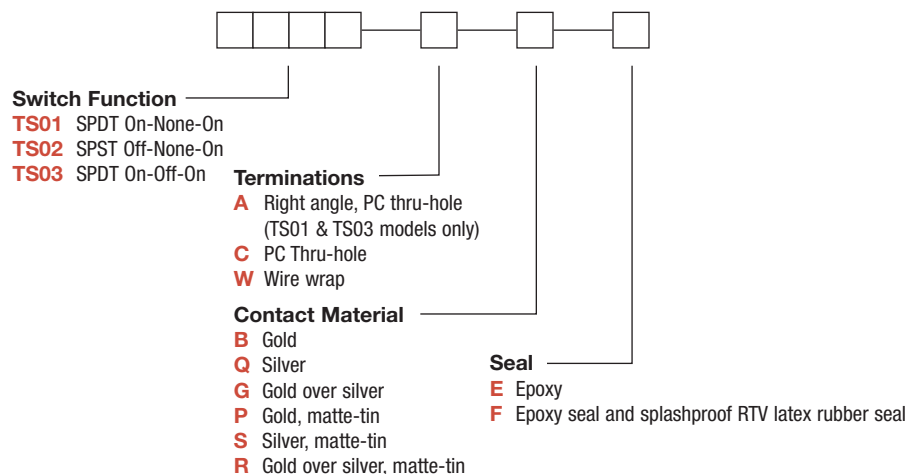





To order, simply select desired option from each category and place in the appropriate box. Available options are shown and described on pages I-9 and I-10. For additional options not shown in catalog, consult Customer Service Center. All models have epoxy terminal seal and are compatible with all "bottom-wash" PCB cleaning methods.



Dimensions are shown: Inch (mm)
Specifications and dimensions subject to change

TS Series Tiny Slide Switches

SWITCH FUNCTION

| NO. POLES | MODEL NO. | SWITCH FUNCTION | | | CONNECTED TERMINALS | | | SCHEMATIC |
|-----------|-------------|---|---|---|---|--|---|--|
| | | POS. 1 | POS. 2 | POS. 3 | POS. 1 | POS. 2 | POS. 3 | |
| | |  |  |  |  |  |  | |
| | | C&K marking on opposite side | | | | | | |
| SP | TS01 | ON | NONE | ON | 1-2 | OPEN | 2-3 |  |
| | TS03 | ON | OFF | ON | | | | SPDT |
| | TS02 | OFF | NONE | ON | OPEN | N/A | 3-1 | SPST  |

SPDT

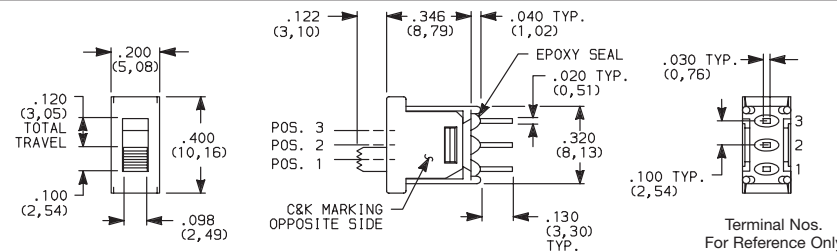

Part number shown: TS01CBE

TS02 models: Omit center terminal

Terminal Nos. For Reference Only

All models  with all options when ordered with G, Q, R or S contact material.

TS02 model not available with A terminations.

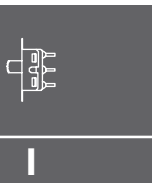

Slide

TERMINATIONS

C PC THRU-HOLE

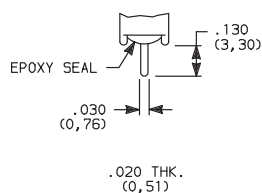

PC MOUNTING

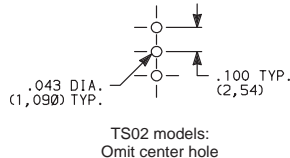

W WIRE WRAP

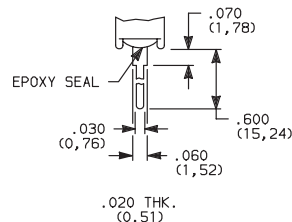

SPDT and SPST

SPDT and SPST

A RIGHT ANGLE, PC THRU-HOLE

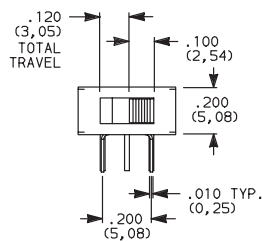

Actuator shown in pos. 1

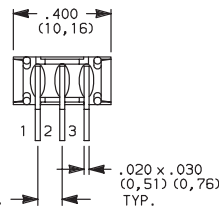
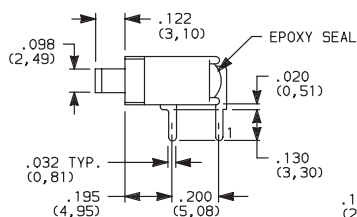

PC MOUNTING

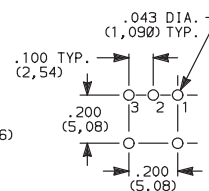

TS01ABE
Horizontal Actuation
SPDT

Not available with TS02 model.



Dimensions are shown: Inches (mm)
Specifications and dimensions subject to change



TS Series Tiny Slide Switches

CONTACT MATERIAL

| OPTION CODE | CONTACT MATERIAL | TERMINAL PLATING | RATINGS | |
|-------------|------------------------------------|------------------------|-----------------------------------|--|
| B | GOLD ¹ | GOLD ³ | LOW LEVEL/DRY CIRCUIT | 0.4 VA MAX. @ 20 V AC OR DC MAX. |
| P | | MATTE-TIN ⁶ | | |
| Q | SILVER ^{4,5} | SILVER ⁵ | POWER | TS01 MODELS: 3 AMPS @ 120 V AC OR 28 V DC. TS02, TS03 MODELS: 1 AMP @ 120 V AC OR 28 V DC. |
| S | | MATTE-TIN ⁶ | | |
| G | GOLD OVER SILVER ^{2,3} | GOLD ³ | LOW LEVEL/DRY CIRCUIT OR POWER | TS01 MODELS: 0.4 VA MAX @20 V AC OR DC MAX. OR 3 AMPS @ 120 V AC OR 28 V DC. TS02, TS03 MODELS: 0.4 VA MAX @ 20 V AC OR DC MAX. OR 1 AMP @ 120 V AC OR 28 V DC. |
| R | | MATTE-TIN ⁶ | | |

* Note: See Technical Data section of this catalog for RoHS compliant and compatible definitions and specifications.

¹ CONTACTS & TERMINALS: Copper alloy, with gold plate over nickel plate.

² END CONTACTS: Coin silver, with gold plate over nickel plate.

³ CENTER CONTACTS & ALL TERMINALS: Copper alloy, with gold plate over nickel plate.

⁴ END CONTACTS: Coin silver, silver plated.

⁵ CENTER CONTACT & ALL TERMINALS: Copper alloy, silver plated.

⁶ TERMINALS: Copper alloy, with matte-tin over nickel plate

All models  with all options when ordered with G, S or R contact material.

B contact material standard with A and W terminations.

Q contact material standard with C terminations.

NOTE: Any models supplied with Q, B, G, P, S or R contact material are RoHS compliant.

SEAL

E EPOXY SEAL

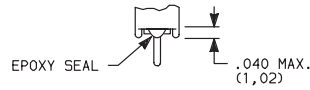

F EPOXY SEAL AND SPLASHPROOF RTV LATEX RUBBER SEAL



NOTE: RTV latex rubber seal peels off easily after installation. Epoxy terminal seal standard. Not available with A termination.

1000 Series Miniature Slide Switches

Features/Benefits

- Variety of actuators and terminations
- Panel mount tabs available
- Epoxy terminal seal—compatible with bottom-wash cleaning
- RoHS compliant

Typical Applications

- Test & measurement equipment
- Telecommunications
- Computer & peripherals

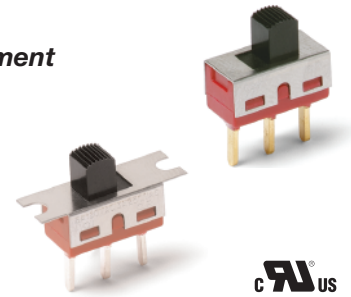

C&K[®] US

Models Available

Specifications

CONTACT RATING: B contact material: 0.4 VA max. @ 20 V AC or DC max. Q contact material: 6 AMPS @ 120 V AC or 28 V DC, 3 AMPS @ 250 V AC. See page I-16 for additional ratings.

ELECTRICAL LIFE: 100,000 make-and-break cycles at full load on models with B, K or P contact material; 40,000 cycles on models with G, Q, L, M, S or R contact material.

CONTACT RESISTANCE: Below 10 m Ω typ. initial @ 2-4 V DC, 100 mA, for both silver and gold plated contacts.

INSULATION RESISTANCE: 10⁹ Ω min.

DIELECTRIC STRENGTH: 1,000 Vrms min. @ sea level.

OPERATING TEMPERATURE: -30°C to 65°C

SOLDERABILITY: Per MIL-STD-202F method 208D, or EIA RS-186E method 9 (1 hour steam aging).

Materials

CASE: diallyl phthalate (DAP), (UL 94V-0).

ACTUATOR: Nylon, black, standard.

HOUSING: Stainless steel.

SWITCH SUPPORT: Brass or steel, matte-tin plated.

END CONTACTS: B contact material: Copper alloy, with gold plate over nickel plate. Q contact material: Coin silver, silver plated. See page I-16 for additional contact materials.

CENTER CONTACT & ALL TERMINALS: B contact material: Copper alloy, with gold plate over nickel plate. Q contact material: Copper alloy, silver plated. See page I-16 for additional contact materials.

TERMINAL SEAL: Epoxy. Refer to Soldering and Cleaning in Technical Data chapter

NOTE: Any models supplied with Q, B, G, P, S or R contact material are RoHS compliant.

NOTE: Specifications and materials listed above are for switches with standard options.

For information on specific and custom switches, consult Customer Service Center.

Build-A-Switch

To order, simply select desired option from each category and place in the appropriate box. Available options are shown and described on pages I-12 through I-16. For additional options not shown in catalog, consult Customer Service Center. All models have epoxy terminal seal and are compatible with all “bottom-wash” PCB cleaning methods.

| | | | | | | | | | |
|--|--|--|--|--|--|--|--|--|--|
| | | | | | | | | | |
| Switch Function | | | | | | | | | |
| 1101 SP On-None-On | | | | | | | | | |
| 1103 SP On-Off-On | | | | | | | | | |
| 1108 SP Mom-None-On | | | | | | | | | |
| 1201 DP On-None-On | | | | | | | | | |
| 1203 DP On-Off-On | | | | | | | | | |
| Mounting Style | | | | | | | | | |
| M2 PC mount without tabs | | | | | | | | | |
| M1 Panel mount with tabs | | | | | | | | | |
| Actuator | | | | | | | | | |
| S3 .200" high | | | | | | | | | |
| S1 .040" high | | | | | | | | | |
| S2 .140" high | | | | | | | | | |
| S4 .285" high | | | | | | | | | |
| S5 .370" high | | | | | | | | | |
| S6 .485" high | | | | | | | | | |
| T3 .200" high | | | | | | | | | |
| Terminations | | | | | | | | | |
| A Right angle, PC thru-hole | | | | | | | | | |
| C PC Thru-hole | | | | | | | | | |
| AV2 Vertical right angle, PC thru-hole | | | | | | | | | |
| Z Solder lug | | | | | | | | | |
| V3 V-bracket | | | | | | | | | |
| V4 V-bracket | | | | | | | | | |
| W .750" long, wire wrap | | | | | | | | | |
| Z3 Quick connect | | | | | | | | | |
| Contact Material | | | | | | | | | |
| B Gold | | | | | | | | | |
| Q Silver | | | | | | | | | |
| G Gold over silver | | | | | | | | | |
| P Gold, matte-tin | | | | | | | | | |
| S Silver, matte-tin | | | | | | | | | |
| R Gold over silver, matte-tin | | | | | | | | | |
| Seal | | | | | | | | | |
| E Epoxy | | | | | | | | | |
| D No epoxy seal | | | | | | | | | |
| I Epoxy potted base | | | | | | | | | |
| Actuator Color | | | | | | | | | |
| 2 Black | | | | | | | | | |
| 1 White | | | | | | | | | |
| 3 Red | | | | | | | | | |



Dimensions are shown: Inches (mm)
Specifications and dimensions subject to change

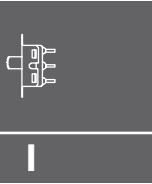

Slide

1000 Series Miniature Slide Switches

SWITCH FUNCTION

| NO. POLES | MODEL NO. | SWITCH FUNCTION | | | CONNECTED TERMINALS | | | SCHEMATIC |
|---|-----------|-----------------|--------|--------|---------------------|--------|---------|-----------|
| | | POS. 1 | POS. 2 | POS. 3 | POS. 1 | POS. 2 | POS. 3 | |
| SP | 1101 | ON | NONE | ON | | N/A | | |
| | 1103 | ON | OFF | ON | 1-2 | OPEN | 2-3 | |
| | 1108 | MOM. | NONE | ON | | N/A | | |
| <p>SPDT</p> <p>Part number shown: 1101M2S3CQE2</p> <p>Terminal Nos. For Reference Only</p> | | | | | | | | |
| DP | 1201 | ON | NONE | ON | 2-1,5-4 | OPEN | 2-3,5-6 | |
| | 1203 | ON | OFF | ON | | | | |
| <p>DPDT</p> <p>Part number shown: 1201M2S3CQE2</p> <p>Terminal Nos. For Reference Only</p> | | | | | | | | |

MOM. = Momentary

All models with all options when ordered with G, Q, S or R contact material.

MOUNTING STYLE

M2 PC MOUNTING WITHOUT TABS

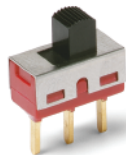

M1 PANEL MOUNTING WITH TABS

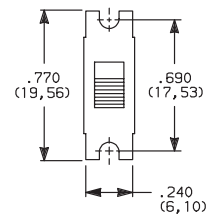
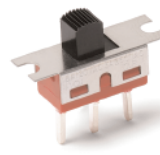

NOTE: Available with A, AV2, C, V3, V4, W terminations only.

NOTE: Available with C, W, Z, Z3 terminations only. No mounting hardware supplied.

PANEL MOUNTING

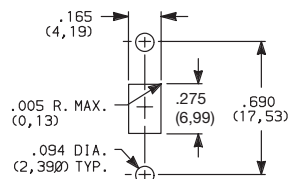

All actuators except T3.
Single pole

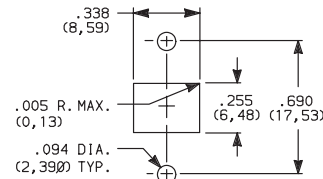

For T3 actuator only.
Double pole



Third Angle Projection
Dimensions are shown: Inch (mm)
Specifications and dimensions subject to change



1000 Series Miniature Slide Switches

ACTUATOR

S3 .200" HIGH

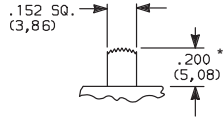

S2 .140" HIGH

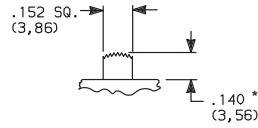

110X models only.

S1 .040" HIGH

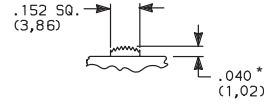

120X models only.

S4 .285" HIGH

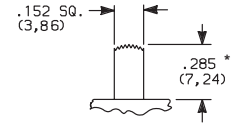

S5 .370" HIGH

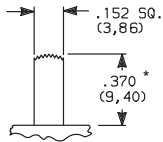

S6 .485" HIGH

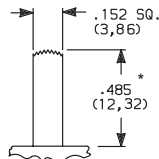

T3 .200" HIGH

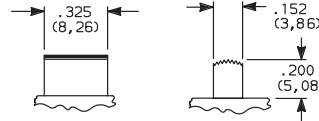

120X models only.

| OPTION CODE | ACTUATOR COLOR |
|-------------|----------------|
| 2 | BLACK |
| 1 | WHITE |
| 3 | RED |
| 7 | BLUE |
| 9 | GRAY |

Other colors available, consult Customer Service Center.

* Subtract .014 (0,36) from actuator height, all models with A, AV2 - 2 pole, V3, V4 terminations.

TERMINATIONS

Z SOLDER LUG

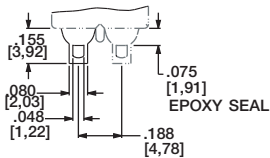

Not available with P, S or R contact materials.

SPDT & DPDT

C PC THRU-HOLE

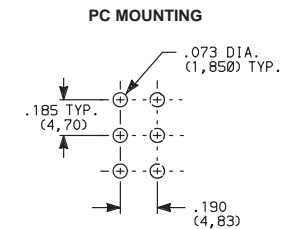
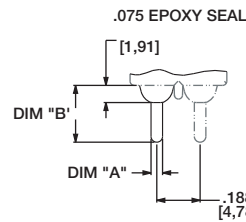

| OPTION | DIM "A" | DIM "B" |
|--------|-------------|-------------|
| C | .050 [0,76] | .250 [6,35] |

SPDT & DPDT

Z3 QUICK CONNECT

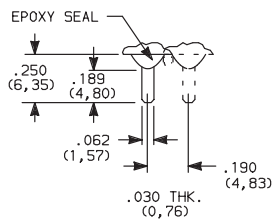

Not available with P, S or R contact materials. Mating quick connector available; order part number 530100000, page I-16.

SPDT & DPDT

W WIRE WRAP

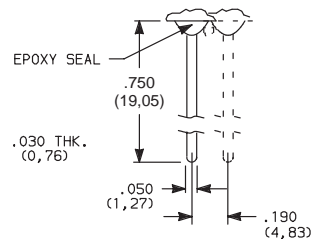

SPDT & DPDT



Third Angle Projection

Dimensions are shown: Inches (mm)
Specifications and dimensions subject to change

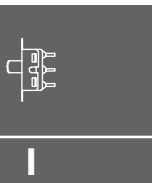

Slide

1000 Series Miniature Slide Switches

TERMINATIONS

A RIGHT ANGLE, PC THRU-HOLE



1101M2S3ABE2
Horizontal Actuation
SPDT

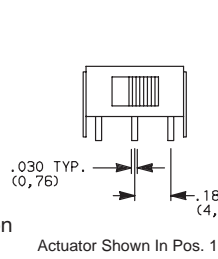

Actuator Shown In Pos. 1

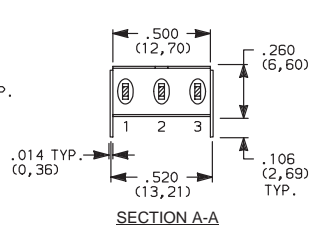
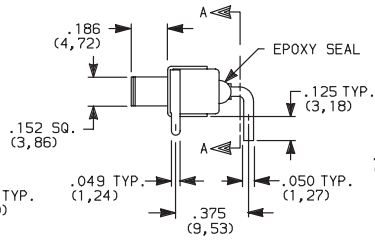

PC MOUNTING

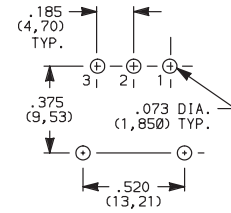

Not available with M1 mounting style, I seal option.
Terminal bend radii and lead-in manufacturing option.

A RIGHT ANGLE, PC THRU-HOLE



1201M2S3ABE2
Horizontal Actuation
DPDT

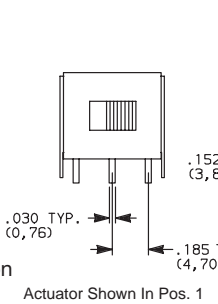

Actuator Shown In Pos. 1

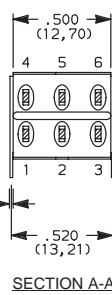
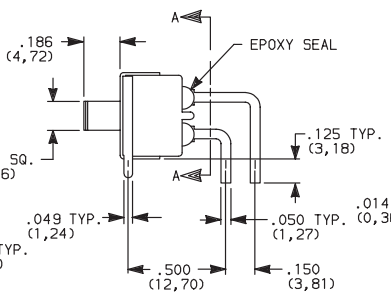

PC MOUNTING

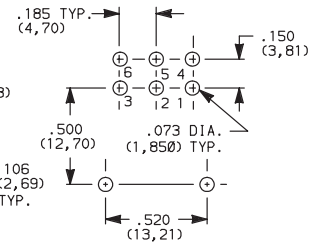

Not available with M1 mounting style, I seal option.
Terminal bend radii and lead-in manufacturing option.

AV2 VERTICAL RIGHT ANGLE, PC THRU-HOLE,
.150" PITCH

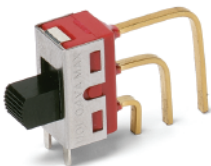

1101M2S3AV2BE2
Vertical Actuation
SPDT

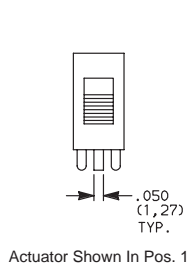

Actuator Shown In Pos. 1

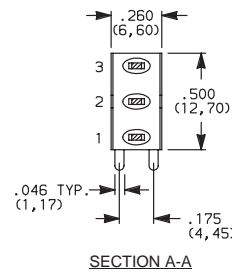
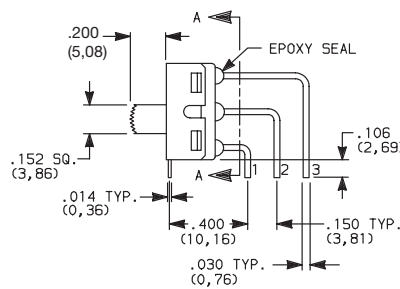

PC MOUNTING

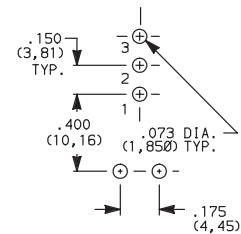

Not available with M1 mounting style, I seal option.
Terminal bend radii and lead-in manufacturing option.

Slide

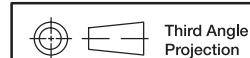

Dimensions are shown: Inch (mm)
Specifications and dimensions subject to change

1000 Series Miniature Slide Switches

TERMINATIONS

AV2 VERTICAL RIGHT ANGLE, PC THRU-HOLE,
.150" PITCH

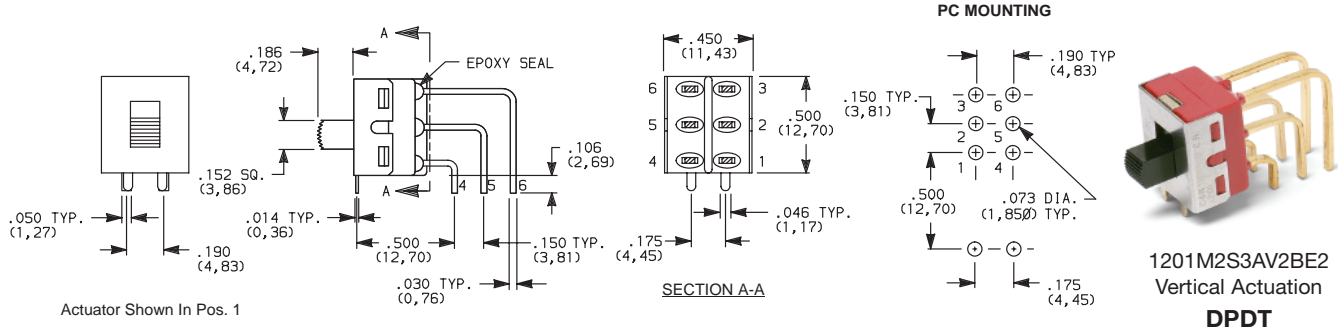

V3, V4 VERTICAL MOUNT,
V-BRACKET

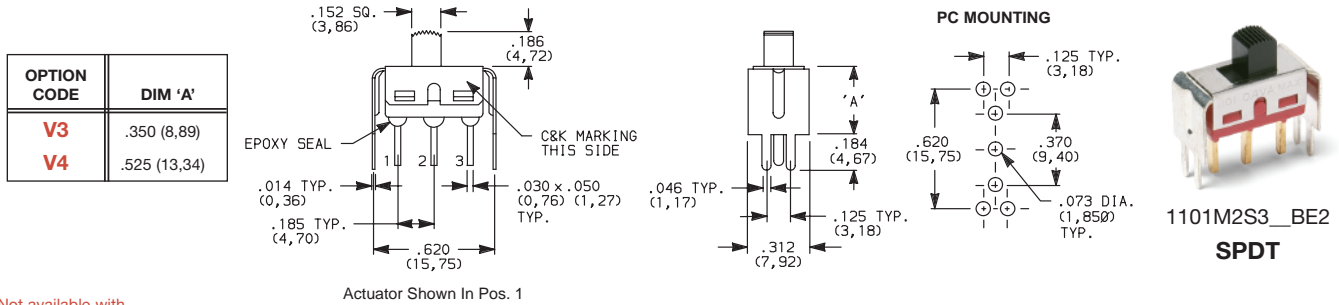

V3, V4 VERTICAL MOUNT,
V-BRACKET

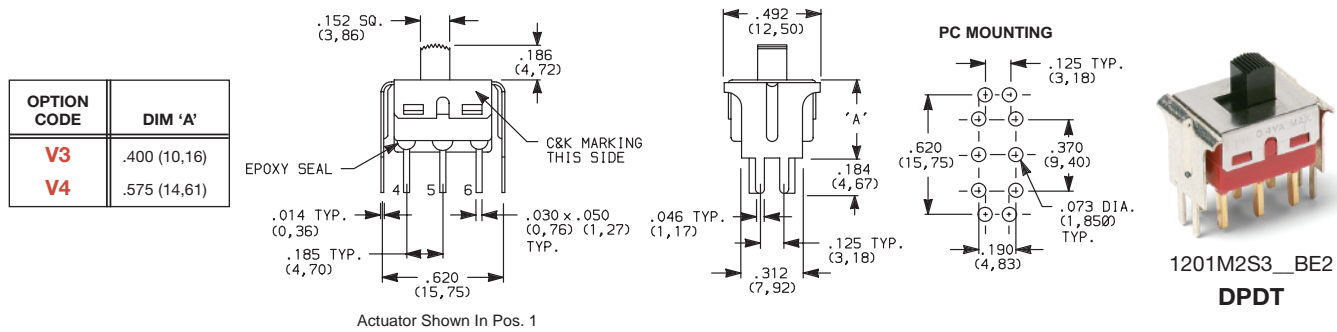

Dimensions are shown: Inches (mm)
Specifications and dimensions subject to change

www.ck-components.com

1000 Series Miniature Slide Switches

CONTACT MATERIAL

| OPTION CODE | CONTACT MATERIAL | TERMINAL PLATING | RATINGS | |
|-------------|------------------------------------|------------------------|-----------------------------------|--|
| B | GOLD ¹ | GOLD ³ | LOW LEVEL/ DRY CIRCUIT | 0.4 VA MAX. @ 20 V AC OR DC MAX. |
| P | | MATTE-TIN ⁶ | | |
| Q | SILVER ^{4,5} | GOLD ³ | POWER | 6 AMPS @ 120 V AC OR 28 V DC; 3 AMPS @ 250 V AC. |
| S | | MATTE-TIN ⁶ | | |
| G | GOLD OVER SILVER ^{2,3} | GOLD ³ | LOW LEVEL/DRY CIRCUIT OR POWER | 0.4 VA MAX @ 20 V AC OR DC MAX OR 6 AMPS @ 120 V AC OR 0.4 MAX. 28 V DC; 3 AMPS @ 250 V AC. |
| R | | MATTE-TIN ⁶ | | |

* Note: See Technical Data section of this catalog for RoHS compliant and compatible definitions and specifications.

¹ CONTACTS & TERMINALS: Copper alloy, with gold plate over nickel plate.

² END CONTACTS: Coin silver, with gold plate over nickel plate.

³ CENTER CONTACTS & ALL TERMINALS: Copper alloy, with gold plate over nickel plate.

⁴ END CONTACTS: Coin silver, silver plated.

⁵ CENTER CONTACT & ALL TERMINALS: Copper alloy, silver plated.

⁶ TERMINALS: Copper alloy, with matte-tin over nickel plate.

All models **C** **AL** **US** with all options when ordered with G, Q, S or R contact material.

B contact material standard with all terminations except C, Z, Z3.

Q contact material standard with C, Z, Z3 terminations.

P, S or R contact materials not available with Z, Z3 terminations.

NOTE: Any models supplied with Q, B, G, P, S or R contact material are RoHS compliant.

SEAL

E EPOXY SEAL

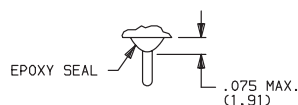

D NO EPOXY SEAL

I EPOXY POTTED BASE

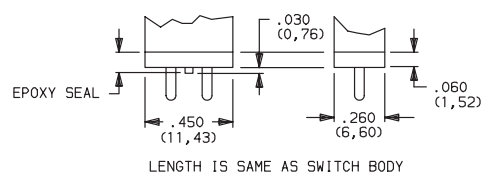

NOTE: Available with C, W, W3, Z, Z3 terminations only.

AVAILABLE HARDWARE

Fits Z3 Termination
female connector



PART NO.
530100000

Available in loose pieces.

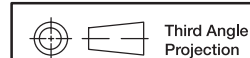

Dimensions are shown: Inch (mm)
Specifications and dimensions subject to change

GS Series Sealed Ultraminiature Slide Switches

Features/Benefits

- Ultraminiature design saves PCB space
- Sealed construction, process compatible with most PCB wash processes
- Available in thru-hole and surface mount
- Long life contact design
- RoHS compliant

Typical Applications

- Computer peripherals & network products
- Test & measurement equipment
- Telephone & cable modems

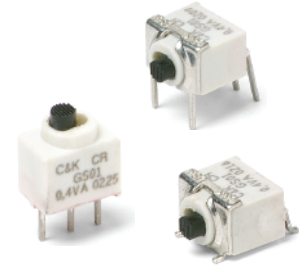

Specifications

CONTACT RATING: 0.4 VA max. @ 20 V AC or DC max.
 MECHANICAL & ELECTRICAL LIFE: 40,000 make-and-break cycles at full load.
 CONTACT RESISTANCE: Below 50 m Ω typ. initial @ 2-4 V DC, 100 mA.
 INSULATION RESISTANCE: 10⁹ Ω min.
 DIELECTRIC STRENGTH: 500 Vrms min. @ sea level.
 STORAGE & OPERATING TEMPERATURE: -40°C to 85°C.
 SOLDERABILITY: Per MIL-STD-202F method 208D, or EIA RS-186E method 9 (1 hour steam aging).
 PACKAGING: Switches available in embossed anti-static tape and reels per EIA 481A. Some models available on embossed anti-static tape and reels per EIA 481-3, consult Customer Service Center.

Materials

HOUSING & BASE: Glass filled 4/6, flame retardant, heat stabilized (UL 94V-0).
 ACTUATOR: Polyetherimide PEI (UL 94V-0), with standard internal seal.
 SWITCH SUPPORT: Brass, matte-tin plated.
 MOVABLE CONTACT: Copper with gold plate over nickel plate.
 STATIONARY CONTACTS: Copper alloy, with gold plate over nickel plate.
 TERMINALS: Copper alloy, with gold plate over nickel plate.
 TERMINAL SEAL: Epoxy. All terminals insert molded.

NOTE: All models are RoHS compliant and compatible with all options.

NOTE: Specifications and materials listed above are for switches with standard options. For information on specific and custom switches, consult Customer Service Center.

How To Order

Complete part numbers for GS Series Sealed Ultraminiature Slide Switches are shown below and on page I-18.

| PART NUMBER | SWITCH FUNCTION | | SCHEMATIC |
|-----------------|-----------------|--------|------------------------------|
| | POS. 1 | POS. 2 | |
| GS01MCBE | ON | ON | 1 ● 2 (COMM) ● 3 SPDT |
| Conn. Terms. | 2-1 | 2-3 | |
| GS02MCBE | OFF | ON | 1 ● 3 SPST |
| Conn. Terms. | OPEN | 3-1 | |
| GS04MCBE | ON | OFF | 1 ● 3 SPST |
| Conn. Terms. | 1-3 | OPEN | |

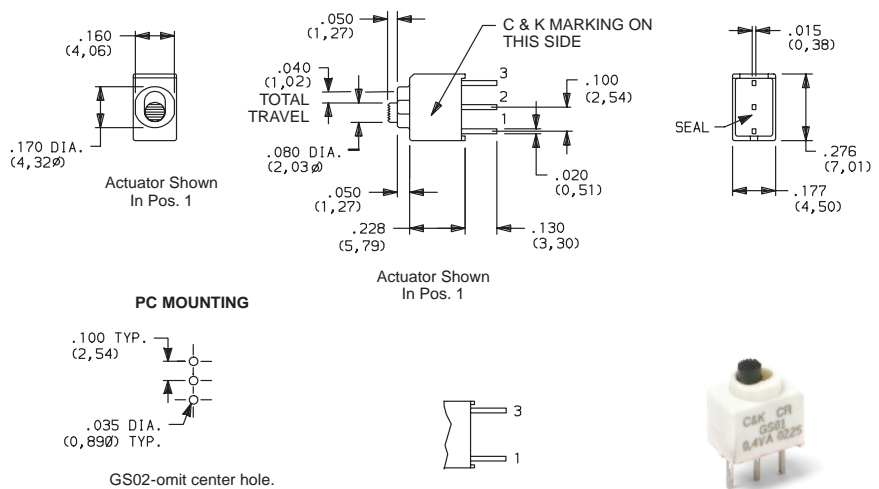

GS01MCBE
SPDT



Third Angle
Projection
Dimensions are shown: Inches (mm)
Specifications and dimensions subject to change

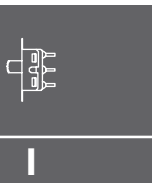

Side

GS Series Sealed Ultraminiature Slide Switches

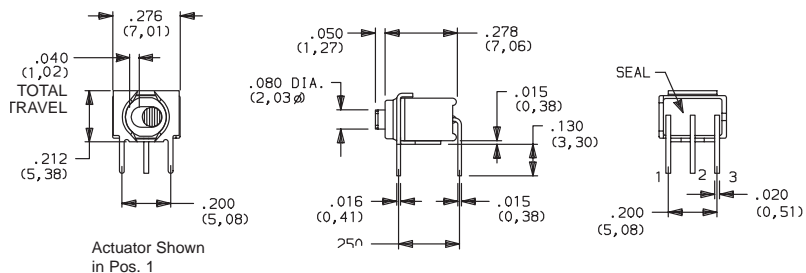

Actuator Shown
in Pos. 1



GS01MABE
Horizontal Actuation
SPDT

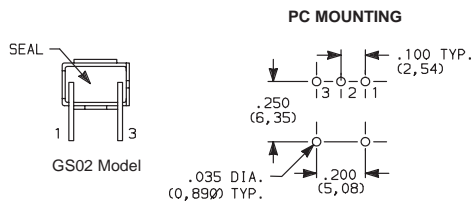

PC MOUNTING

| PART NUMBER | SWITCH FUNCTION | | SCHEMATIC |
|-----------------|-----------------|--------|-----------|
| | POS.1 | POS. 2 | |
| GS01MABE | ON | ON | |
| Conn. Terms. | 2-1 | 2-3 | |
| GS02MABE | OFF | ON | |
| Conn. Terms. | OPEN | 3-1 | |
| GS04MABE | ON | OFF | |
| Conn. Terms. | 1-3 | OPEN | |

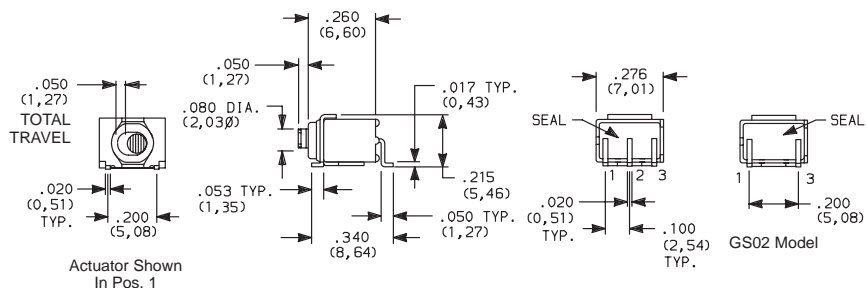

Actuator Shown
in Pos. 1

SMT



GS01MSABE
Horizontal Actuation
SPDT

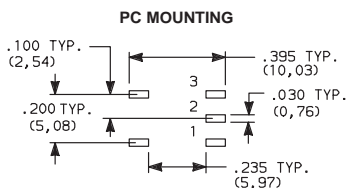

PC MOUNTING

| PART NUMBER | SWITCH FUNCTION | | SCHEMATIC |
|------------------|-----------------|--------|-----------|
| | POS.1 | POS. 2 | |
| GS01MSABE | ON | ON | |
| Conn. Terms. | 2-1 | 2-3 | |
| GS02MSABE | OFF | ON | |
| Conn. Terms. | OPEN | 3-1 | |
| GS04MSABE | ON | OFF | |
| Conn. Terms. | 1-3 | OPEN | |

TAPE & REEL

FOR PART NUMBERS GS01MSABE, GS02MSABE, GS04MSABE

| REEL INFORMATION | |
|-------------------|---------------|
| OUTSIDE DIAMETER | 13.00 (330,0) |
| PILOT HOLE | .512 (13,0) |
| QUANTITY PER REEL | 600 |

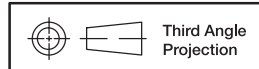
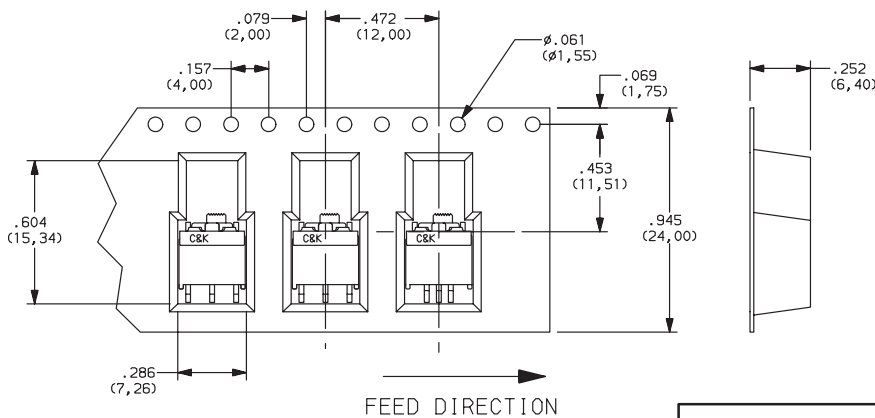

Third Angle
Projection
Dimensions are shown: Inch (mm)
Specifications and dimensions subject to change



L Series Miniature Slide Switches

Features/Benefits

- Positive detent
- Enclosed housing
- Maintained and momentary functions
- PC and panel mounting
- RoHS compliant

Typical Applications

- Communications equipment
- Lighting devices

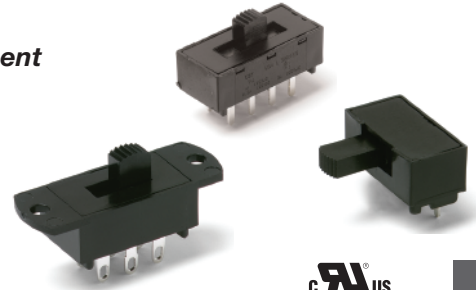

C&K US

Models Available

Specifications

CONTACT RATING: Q contact material (LX0X, LX1X Models): 4 AMPS @ 125 V AC or 28 V DC; 2 AMPS @ 250 V AC; 0.5 AMP @ 125 V DC (UL). See page I-23 for additional ratings.
ELECTRICAL LIFE: 10,000 make-and-break cycles at full load.
CONTACT RESISTANCE: Below 10 m Ω typ. initial @ 2-4 V DC, 100 mA, for both silver and gold plated contacts.
INSULATION RESISTANCE: 10⁹ Ω min.
DIELECTRIC STRENGTH: 1,000 Vrms min. @ sea level.
OPERATING TEMPERATURE: -30°C to +65°C
STORAGE TEMPERATURE: -30°C to +85°C

NOTE: Specifications and materials listed above are for switches with standard options. For information on specific and custom switches, consult Customer Service Center.

Materials

HOUSING: 6/6 nylon (UL94V-2), black.
ACTUATOR: 6/6 nylon (UL94V-2), black. '13' actuator, natural (standard).
CONTACTS: Q contact material: Copper, silver plated. See page I-23 for additional contact materials.
TERMINALS: Q contact material: Copper, silver plated. See page I-23 for additional contact materials.
CONTACT SPRING: Music wire or stainless steel.
TERMINAL SEAL: Epoxy.

NOTE: Any models supplied with Q, B or G contact material are RoHS compliant.

Build-A-Switch

To order, simply select desired option from each category and place in the appropriate box. Available options are shown and described on pages I-20 through I-24. For additional options not shown in catalog, consult Customer Service Center.

| | | | | | | | | | | | | | | |
|------------------------------|--|--------------------------------|--|------------------|--|--------------------------------------|--|--------------------------|--|-------------------------|--|--------------|--|------------------|
| | | | | | | | | | | | | | | |
| Switch Function | | Actuator | | Detent | | Mounting Style | | Terminations | | Contact Material | | Seal | | Cap Color |
| L202 DPDT | | 01 .200" high | | 1 With detent | | MS PC Thru-hole | | 02 PC Thru-hole | | Q Silver | | NONE No seal | | 2 Black |
| L203 DP3T | | 02 .335" high | | 2 Without detent | | MA Right angle, PC thru-hole | | 03 Solder lug with notch | | B Gold | | E Epoxy seal | | NONE No cap |
| L101 SPST | | 03 .375" high | | | | ML Right angle, PC thru-hole | | 04 PC Thru-hole | | G Gold over silver | | | | |
| L102 SPDT | | 05 .312" high | | | | MV Right angle, PC thru-hole | | 06 Wire wrap | | | | | | |
| L103 SP3T | | 11 .100" high | | | | SS Panel with mounting ears | | 12 PC Thru-hole | | | | | | |
| L104 SP4T | | 12 Screwdriver slot | | | | TS Panel with integral mounting ears | | | | | | | | |
| L112 SPDT, mom. | | 13 Plunger without cap | | | | | | | | | | | | |
| L113 SP3T, mom. to one end | | 14 Plunger with .200" dia. cap | | | | | | | | | | | | |
| L123 SP3T, mom. to both ends | | 15 Plunger with .310" dia. cap | | | | | | | | | | | | |
| L201 DPST | | 17 Plunger with .458" dia. cap | | | | | | | | | | | | |
| L204 DP4T | | 19 Plunger with .590" dia. cap | | | | | | | | | | | | |
| L212 DPDT, mom. | | | | | | | | | | | | | | |



Dimensions are shown: Inches (mm)
Specifications and dimensions subject to change

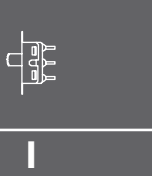

Slide

L Series Miniature Slide Switches

SWITCH AND LOCK FUNCTION



| NO. POLES | MODEL NO. | SWITCH FUNCTION | SCHEMATIC | AVAILABLE MOUNTING STYLES |
|-----------|-----------|------------------------|-----------|---------------------------|
| SP | L101 | SPST | | ML, MS, SS |
| | L102 | SPDT | | ML, MS, SS |
| | L112 | SPDT-MOM. | | ML, MS, MV, SS |
| | L103 | SP3T | | MA, MS, TS |
| | L113 | SP3T-MOM. to one end | | MA, MS, TS |
| | L123 | SP3T-MOM. to both ends | | MA, MS, TS |
| | L104 | SP4T | | MS |

| NO. POLES | MODEL NO. | SWITCH FUNCTION | SCHEMATIC | AVAILABLE MOUNTING STYLES |
|-----------|-----------|-----------------|-----------|---------------------------|
| DP | L201 | DPST | | MA, MS, SS |
| | L202 | DPDT | | MA, MS, SS |
| | L212 | DPDT-MOM. | | MV |
| | L203 | DP3T | | MS, TS |
| | L204 | DP4T | | MS |

NOTE: and MOM. in table indicates momentary action.

All models with all options when ordered with 'G' or 'Q' contact material.

Contacts make on side actuator thrown.

ACTUATOR



ACTUATOR OPTIONS FOR 'MS, MA, ML, SS, & TS' MOUNTING STYLES

01 .200" HIGH
 02 .335" HIGH
 03 .375" HIGH
 05 .312" HIGH
 11 .100" HIGH
 12 SCREWDRIVER SLOT

NOTE: No actuator color option code is required. Standard actuator color is black, other colors and heights available, consult Customer Service Center. See pages I-20 and I-22 for available mounting styles.

ACTUATOR OPTIONS FOR 'MV' MOUNTING STYLE

13 PLUNGER WITHOUT CAP
 14 PLUNGER WITH CAP
 15 PLUNGER WITH CAP

17 PLUNGER WITH CAP
 19 PLUNGER WITH CAP

Cap part number 7089
 Cap part number 8018

| OPTION CODE | ACTUATOR CAP COLORS |
|-------------|---------------------|
| 2 | BLACK |
| NONE | 01-13 ACTUATORS |

Other colors available, consult Customer Service Center.

ACTUATOR CAPS

Caps supplied are not installed standard. To order actuator options '14 thru 19,' select desired cap color from chart and place option code in last box of ordering format. Leave box empty for all other actuator options. Caps may also be ordered separately and user installed, see pages I-23 and I-24. Specify the four digit part number and desired cap color. For switches without caps, order '13' or '23' actuator option. Cap finish: gloss (excluding square cap part number 7982, finish: matte).

SPLASH CAPS

New protective splash caps for PC mounted slide switches are available separately and reusable. They provide splash protection during soldering and cleaning processes. To order specify correct part number, see page I-24.



Dimensions are shown: Inch (mm)

Specifications and dimensions subject to change



L Series Miniature Slide Switches

DETENT

1 WITH DETENT

Standard with all maintained models: L101, L102, L103, L104, L113, L201, L202, L203 and L204.

2 WITHOUT DETENT

Standard with all momentary models: L112, L123, and L212.

MOUNTING STYLE

MS PC THRU-HOLE, 2 POSITION MODELS

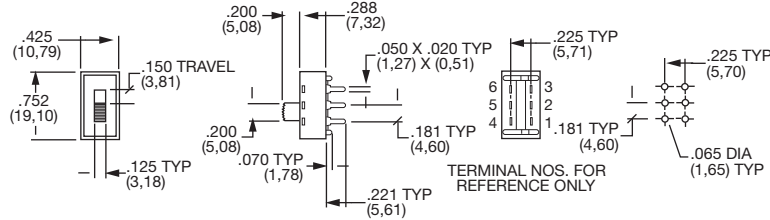

AVAILABLE WITH:

Models: L101, L102, L112, L103, L113 L123, L201, L202, L203, L104 and L204

Terminations: 02, 06, 10 and 12

Actuators: 01, 02, 03, 05, 11 and 12

PC MOUNTING

For mounting information, see TERMINATIONS section, page I-23.

Splash caps are available separately and reusable, see page I-24.

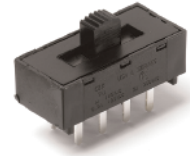

L203011MS02Q
DP3T

PC THRU-HOLE, 3 POSITION MODELS

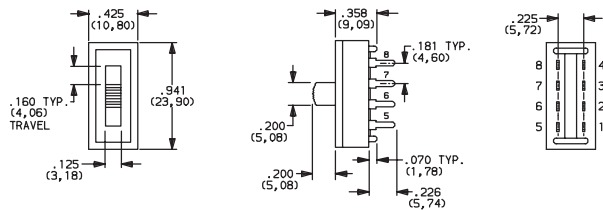

PC THRU HOLE, 4 POSITION MODELS

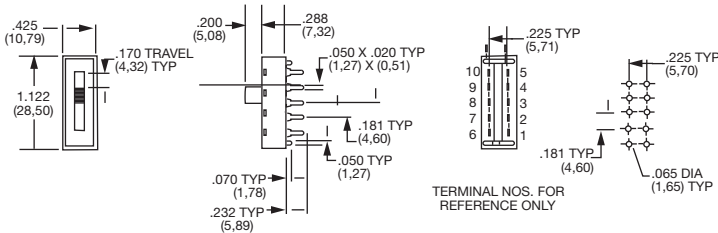

MA RIGHT ANGLE, PC THRU-HOLE

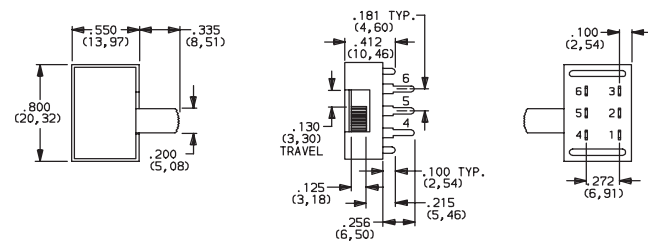

AVAILABLE WITH:

Models: L103, L201, L202, L113 and L123

Terminations: 04

Actuators: 02 and 12

PC MOUNTING

For mounting information, see TERMINATIONS section, page I-23.

Splash caps are available separately and reusable, see page I-24.

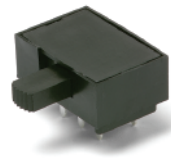

L202021MA04Q
Horizontal Actuation
DPDT

RIGHT ANGLE, PC, SP-3 POSITION MODELS

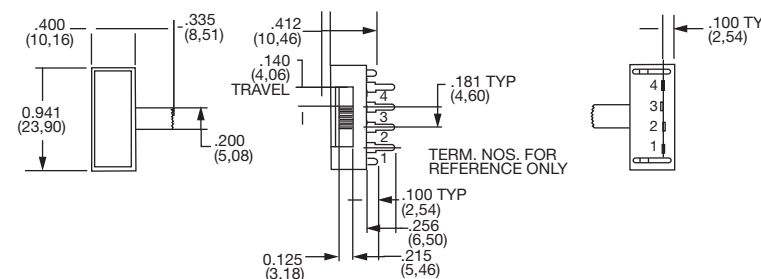

Third Angle
Projection

Dimensions are shown: Inches (mm)

Specifications and dimensions subject to change

C&K

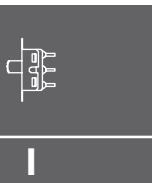

Slide

L Series Miniature Slide Switches

MOUNTING STYLE



ML RIGHT ANGLE, PC THRU-HOLE

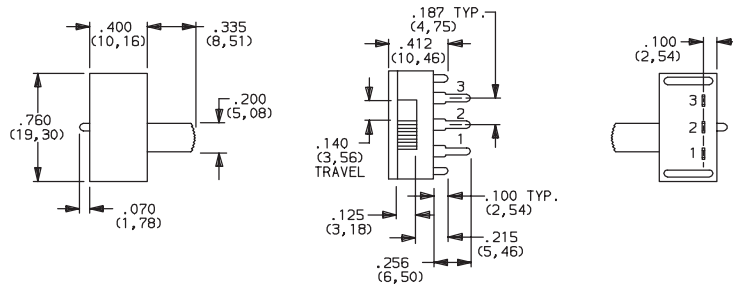

AVAILABLE WITH:

Models: L101, L102, L112
Terminations: 04
Actuators: 01, 02, 05, 11 and 12
PC MOUNTING

For mounting information, see TERMINATIONS section, page I-23.

Splash caps are available separately and reusable, see page I-24.



L102021ML04Q
Horizontal Actuation
SPDT

MV RIGHT ANGLE, PC THRU-HOLE

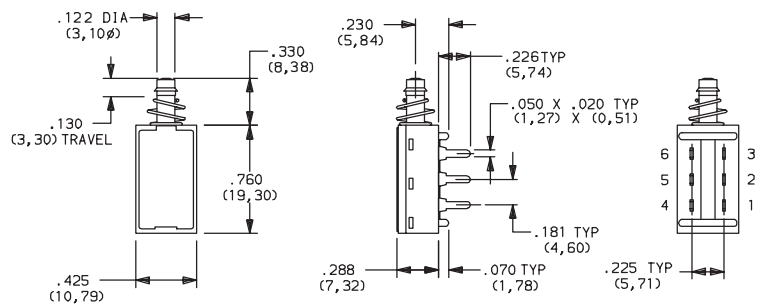

AVAILABLE WITH:

Models: L112 and L212
Terminations: 02, 06, 10 and 12
Actuators: 13 thru 19

PC MOUNTING

For mounting information, see TERMINATIONS section, page I-23.

Splash caps are available separately and reusable, see page I-24.



L212132MV02Q
DPDT

SS PANEL WITH MOUNTING EARS



L202011SS03Q
DPDT

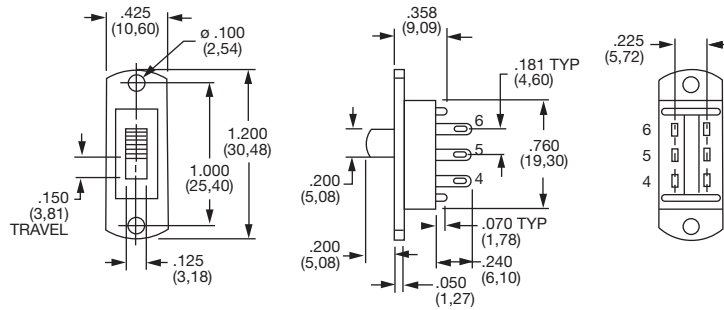

PANEL MOUNTING

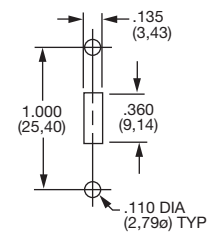

AVAILABLE WITH:

Models: L101, L102, L112, L201 and L202
Terminations: 01, 02, 03, 06, 10, 12
Actuators: 01, 02, 03, 05, 11 and 12

TS PANEL WITH INTEGRAL MOUNTING EARS



L203011TS03Q
DP3T

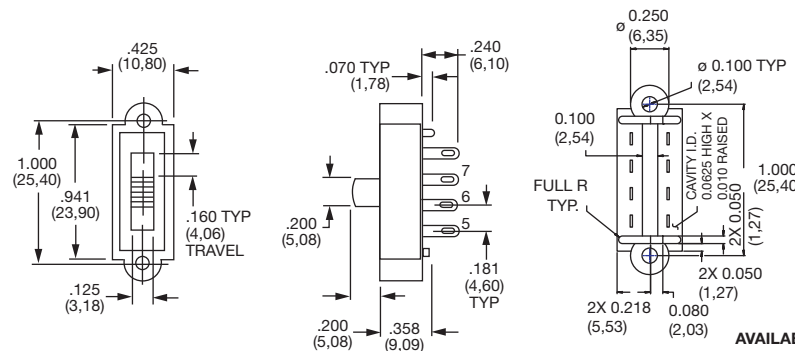

PANEL MOUNTING

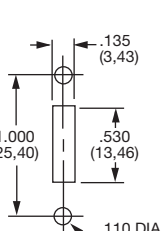

AVAILABLE WITH:

Models: L103, L113, L123 and L203
Terminations: 01, 02, 03, 06, 10, 12
Actuators: 01, 02, 03, 05, 11 and 12

Slide



Slide

Slide

Slide

Slide

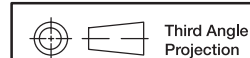

Dimensions are shown: Inch (mm)
Specifications and dimensions subject to change

L Series Miniature Slide Switches

TERMINATIONS

'MS, MV, SS & TS' Mounting Styles Only

02 PC THRU-HOLE

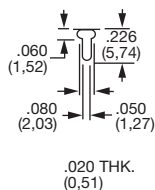

01 SOLDER LUG WITH NOTCH

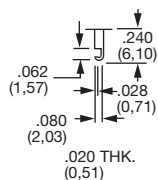

03 SOLDER LUG WITH HOLE

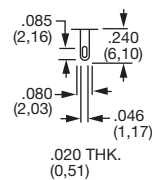

10 PC THRU-HOLE

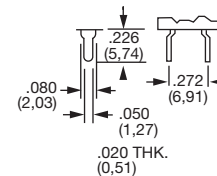

12 PC THRU-HOLE

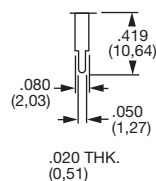

06 WIRE WRAP

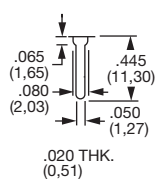

'MA & ML' Mounting Styles Only

04 PC THRU-HOLE

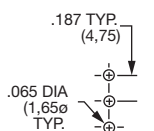
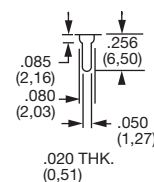

All models with '04' terminations and 'ML' mounting style.

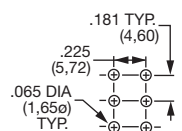

All 2 position models, except '04' and '10' terminations.

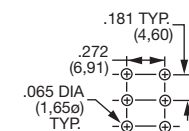

All 2 position models with '04' and '10' terminations.

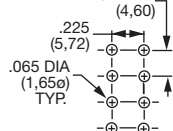

All 3 position models except '04' and '10' terminations.

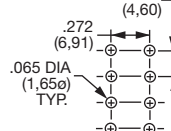

All 3 position models, with '10' termination.

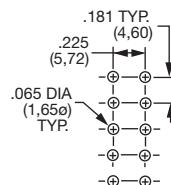

All 4 position models, except '04' and '10' terminations.

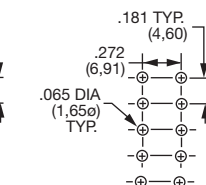

All 4 position models, with '10' terminations.

CONTACT MATERIAL

| OPTION CODE | CONTACT MATERIAL | RATINGS | |
|-------------|-------------------------------|--------------------------------|--|
| | | | |
| Q | SILVER ² | LOW LEVEL/DRY CIRCUIT | LX0X, LX1X MODELS: 4 AMPS @ 125 V AC or 28 V DC; 2 AMPS @ 250 V AC; 0.5 AMP @ 125 V DC (UL). LX6X MODELS: 4 AMPS @ 125 V AC or 28 V DC; 2 AMPS @ 250 V AC (UL). |
| B | GOLD ¹ | POWER | 0.4 VA MAX. @20 V AC OR DC max. |
| G | GOLD OVER SILVER ³ | LOW LEVEL/DRY CIRCUIT OR POWER | LX0X, LX1X MODELS: 0.4 VA MAX. @ 20 V AC or DC MAX. or 4 AMPS @ 125 V AC or 28 V DC; 2 AMPS @ 250 V AC; 0.5 AMP @ 125 V DC (UL). LX6X MODELS: 0.4 VA MAX. @ 20 V AC or DC MAX. or 4 AMPS @ 125 V AC or 28 V DC; 2 AMPS @ 250 V AC (UL). |

* Note: See Technical Data section of this catalog for RoHS compliant and compatible definitions and specifications.

¹ CONTACTS & TERMINALS: Copper, with gold plate over nickel plate.

² CONTACTS & TERMINALS: Copper, silver plated (standard with all termination options).

³ CONTACTS & TERMINALS: Copper, with gold plate over nickel plate over silver plate.

NOTE: Any models supplied with Q, B or G contact material are RoHS compliant.

All models  with all options when ordered with 'G' or 'Q' contact material.

NOTE: 'G' contact material is equivalent to both 'B' and 'Q' contact materials.

SEAL

NONE NO SEAL

E EPOXY SEAL

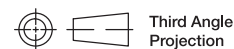
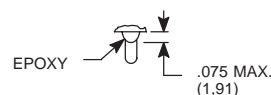

Third Angle Projection

Dimensions are shown: Inches (mm)
Specifications and dimensions subject to change

C&K

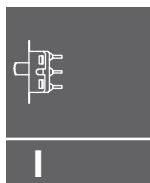

Slide

L Series Miniature Slide Switches

AVAILABLE HARDWARE

Cap
Compatible with 13-19 actuators

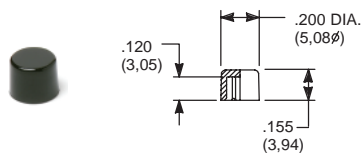

PART NO.
708902000 BLACK
708903000 RED

Material: Nylon
Finish: Gloss

Cap
Compatible with 13-19 actuators

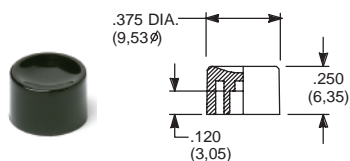

PART NO.
752702000 BLACK
752703000 RED

Material: Nylon
Finish: Gloss

Cap
Compatible with 13-19 actuators

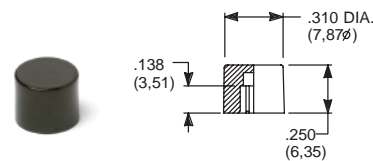

PART NO.
801802000 BLACK
801803000 RED

Material: Nylon
Finish: Gloss

Cap
Compatible with 13-19 actuators

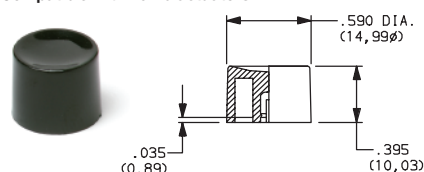

PART NO.
452D02000 BLACK
452D03000 RED

Material: Nylon
Finish: Gloss

Cap
Compatible with 13-19 actuators

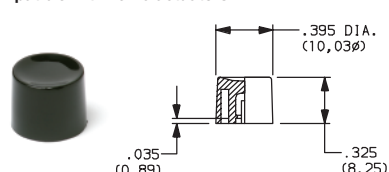

PART NO.
894102000 BLACK
894103000 RED

Material: Nylon
Finish: Gloss

Cap
Compatible with 13-19 actuators

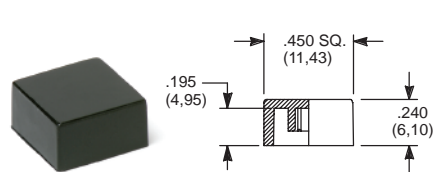

PART NO.
484602000 BLACK
484603000 RED

PART NO.
798202263 BLACK
798203000 RED

Material: Nylon
Finish: Gloss

Material: Nylon
Finish: Matte

Cap
Compatible with 01-05 actuators

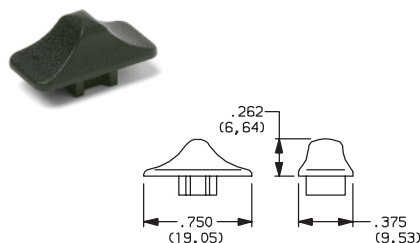

PART NO.
120100602 BLACK

Material: Nylon
Finish: Matte

Splash Cap



Fits 'MS' mounting style,
LXX1 & LXX2 models only.

PART NO.
120100200

Material: Nylon

Splash Cap



Fits 'MV' mounting style,
LX1X models only.

PART NO.
120100300

Material: Nylon

Splash Cap



Fits 'MA' mounting style,
LXX3 models only.

PART NO.
120100400

Material: Nylon

NOTE: Other colors available,
consult Customer Service Center.



Dimensions are shown: Inch (mm)
Specifications and dimensions subject to change

LP Series Miniature Snap-in Slide Switches

Features/Benefits

- 6 to 11 AMPS available
- Easy assembly—Snap-in mounting
- Contamination resistant—extended actuator
- Positive detent
- RoHS compliant

Typical Applications

- Small appliances
- Outdoor appliances
- Portable tools



C&K US
Models Available

Specifications

CONTACT RATING: Q contact material (LP0X, LP2X Models: 6 AMPS @ 125 V AC or 28 V DC; 3 AMPS @ 250 V AC (UL/CSA). (LP7X, LP8X Models): 11 AMPS @ 125/250 V AC (UL/CSA). See page I-27 for additional ratings.

ELECTRICAL LIFE: 10,000 make-and-break cycles at full load.

INSULATION RESISTANCE: $10^9 \Omega$ min.

DIELECTRIC STRENGTH: 1,000 Vrms min. @ sea level.

CONTACT RESISTANCE: Below 10 m Ω typ. initial @ 2-4 V DC, 100 mA, for both silver and gold plated contacts.

OPERATING TEMPERATURE: -30°C to +65°C

STORAGE TEMPERATURE: -30°C to +85°C

NOTE: Any models supplied with Q, B or G contact material are RoHS compliant.

NOTE: Specifications and materials listed above are for switches with standard options. For information on specific and custom switches, consult Customer Service Center.

Materials

HOUSING: 6/6 nylon (UL94V-2), black.

ACTUATOR: Glass filled acetal, UV and petroleum resistant, black.

CONTACTS: Q contact material: Copper, silver plated. See page I-27 for additional contact materials.

TERMINALS: Q contact material: Copper, silver plated. See page I-27 for additional contact materials.

CONTACT SPRING: Music wire or stainless steel.

TERMINAL SEAL: Epoxy.

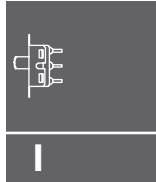

Side

Build-A-Switch

To order, simply select desired option from each category and place in the appropriate box. Available options are shown and described on pages I-26 and I-27. For additional options not shown in catalog, consult Customer Service Center.

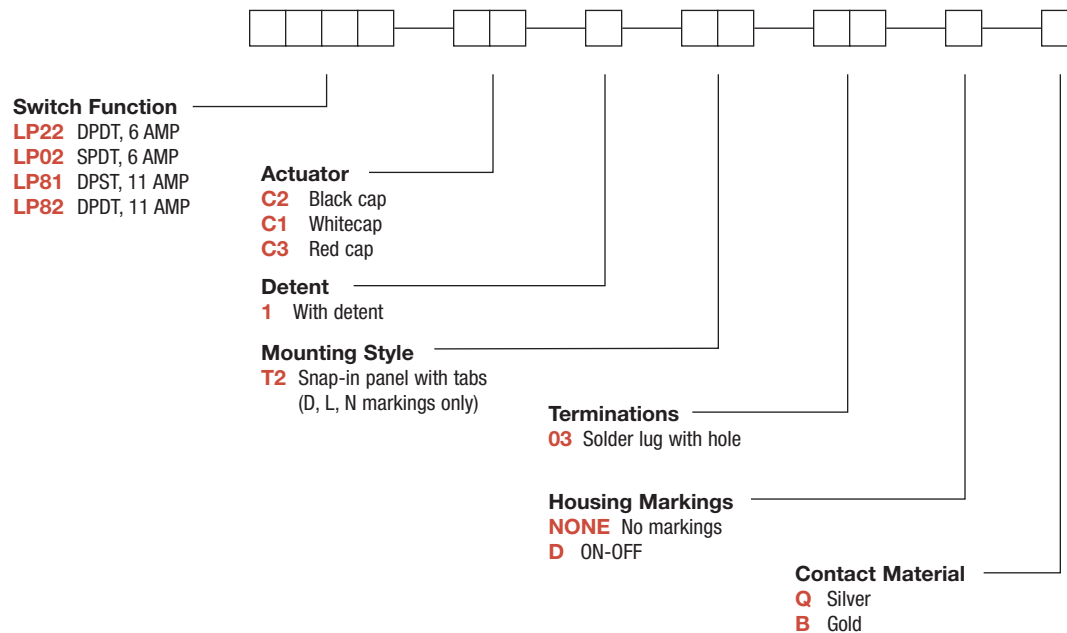

Third Angle Projection

Dimensions are shown: Inches (mm)
Specifications and dimensions subject to change

C&K

LP Series Miniature Snap-in Slide Switches

SWITCH FUNCTION

| NO. POLES | MODEL NO. | AMP RATING* | SWITCH FUNCTION | SCHEMATIC |
|-----------|-------------|-------------|-----------------|-----------|
| SP | LP02 | 6 | SPDT | |

| NO. POLES | MODEL NO. | AMP RATING* | SWITCH FUNCTION | SCHEMATIC |
|-----------|-------------|-------------|-----------------|-----------|
| DP | LP22 | 6 | DPDT | |
| | LP81 | 11 | DPST | |
| | LP82 | 11 | DPDT | |

All models **C^{RU}US** with all options when ordered with 'Q' contact material.
Contacts make on side actuator thrown.

* For complete contact ratings, see CONTACT MATERIALS Section, page I-27.



Slide

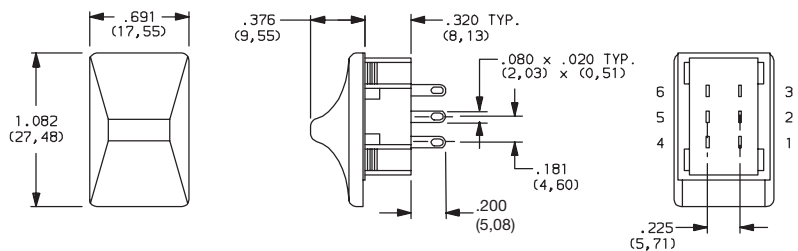

Part number shown: LP22C21S203Q

Terminal Nos.
For Reference Only

ACTUATOR

C1; C2; C3

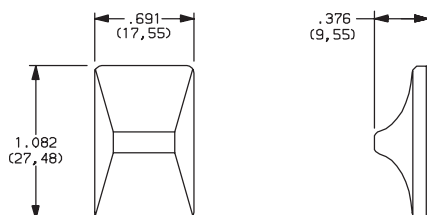

| OPTION CODE2 | ACTUATOR CAP COLOR |
|--------------|--------------------|
| C2 | BLACK |
| C1 | WHITE |
| C3 | RED |

NOTE: Actuator finish: gloss.
Other colors available,
consult Customer Service Center.

DETENT

1 WITH DETENT

MOUNTING STYLE

T2 SNAP-IN PANEL WITH TABS



Mounting style T2 suitable for markings.
See HOUSING MARKINGS options.

| PANEL THICKNESS | DIM 'A' |
|----------------------------|-----------------|
| .030-.045 (0,76) (1,14) | .578 (14,68) |
| .046-.059 (1,17) (1,50) | .585 (14,86) |
| .060-.089 (1,52) (2,26) | .598 (15,19) |
| .090-.120 (2,29) (3,05) | .610 (15,49) |

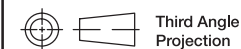
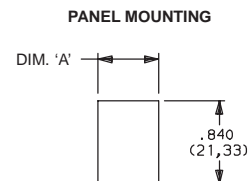

Dimensions are shown: Inch (mm)
Specifications and dimensions subject to change



LP Series Miniature Snap-in Slide Switches

TERMINATIONS

03 SOLDER LUG WITH HOLE

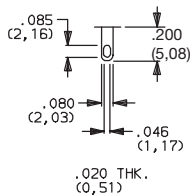

HOUSING MARKINGS

NONE NO MARKINGS

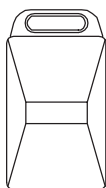

D ON-OFF

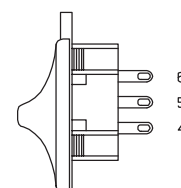
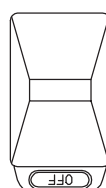
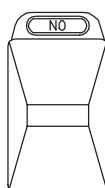

NOTE: Housing markings are available with 'T2' mounting style only. The marking color on all housings with marking options 'D' is white, standard. Other marking colors are available, consult Customer Service Center.

Orientation of actuator and terminals.

CONTACT MATERIAL

| OPTION CODE | CONTACT MATERIAL | RATINGS | |
|-------------|---------------------|-----------------------|--|
| | | | |
| Q | SILVER ² | POWER | LP0X, LP2X MODELS: 6 AMPS @ 125 V AC or 28 V DC; 3 AMPS @ 250 V AC (UL/CSA). LP7X, LP8X MODELS: 11 AMPS @ 125/250 V AC (UL/CSA). |
| B | GOLD ¹ | LOW LEVEL/DRY CIRCUIT | 0.4 VA MAX. @20 V AC OR DC MAX. |

* Note: See Technical Data section of this catalog for RoHS compliant and compatible definitions and specifications.

¹ CONTACTS & TERMINALS: Copper, with gold plate over nickel plate.

² CONTACTS & TERMINALS: Copper, silver plated (standard with all termination options).

³ CONTACTS & TERMINALS: Copper, with gold plate over nickel plate over silver plate.

NOTE: Any models supplied with Q or B contact material are RoHS compliant.

All models  with all when ordered with 'Q' contact material.



Dimensions are shown: Inches (mm)
Specifications and dimensions subject to change

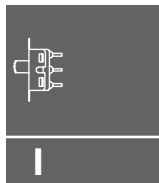

Side

S Series Slide Switches

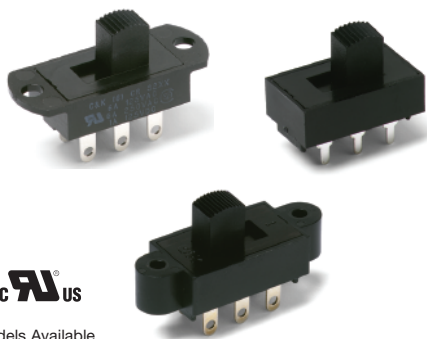

Models Available

Features/Benefits

- 6 to 15 AMPS
- Enclosed housing
- PC and Snap-in panel mounting
- Reversing option
- RoHS compliant

Typical Applications

- Portable tools
- Small appliances
- Floor care products

Specifications

CONTACT RATING: Q contact material (S1XX, S2XX Models): 6 AMPS @ 125 V AC; 6 AMPS @ 250 V AC; 1 AMP @ 125 V DC . (S5XX, S6XX Models): 12 AMPS @ 125 V AC; 6 AMPS @ 250 V AC; 1 AMP @ 125 V DC . (S7XX, S8XX Models): 15 AMPS @ 125 V AC; 6 AMPS @ 250 V AC . See page I-32 for additional ratings.

ELECTRICAL LIFE: 10,000 make-and-break cycles at full load.

CONTACT RESISTANCE: Below 10 m Ω typ. initial @ 2-4 V DC, 100 mA, for both silver and gold plated contacts.

INSULATION RESISTANCE: 10⁹ Ω min.

DIELECTRIC STRENGTH: 1,000 Vrms min. @ sea level.

OPERATING TEMPERATURE: -30°C to +65°C

STORAGE TEMPERATURE: -30°C to +85°C

Materials

HOUSING: 6/6 nylon (UL94V-2), black.

TOP PLATE: 6/6 nylon (UL94V-2), black.

ACTUATOR: 6/6 nylon (UL94V-2), black (standard).

CONTACTS: Q contact material: Copper, silver plated. See page I-32 for additional contact materials.

TERMINALS: Q contact material: Copper, silver plated. See page I-32 for additional contact materials.

CONTACT SPRING: Music wire or stainless steel.

TERMINAL SEAL: Epoxy.

NOTE: Any models supplied with Q, B or G contact material are RoHS compliant.

NOTE: Specifications and materials listed above are for switches with standard options. For information on specific and custom switches, consult Customer Service Center.

Build-A-Switch

To order, simply select desired option from each category and place in the appropriate box. Available options are shown and described on pages I-29 through I-32. For additional options not shown in catalog, consult Customer Service Center.

| | | | | | | | |
|---|---|---|---|--|---|---|--|
| <p>Switch Function</p> <p>S101 SPST, 6 AMPS</p> <p>S202 (DPDT, 6 AMPS</p> <p>S802 DPDT, 15 AMPS</p> <p>S102 SPDT, 6AMPS</p> <p>S112 SPDT, mom., 6 AMPS</p> <p>S201 DPST, 6 AMPS</p> <p>S602 DPDT, 12 AMPS</p> <p>S701 SPST, 15 AMPS</p> <p>S702 SPDT, 15 AMPS</p> | <p>Actuator</p> <p>03 .335" high</p> <p>04 .500" high</p> <p>09 .250" high</p> <p>12 Screwdriver slot (with marking)</p> <p>13 Screwdriver slot (without marking)</p> <p>C2 Black cap</p> <p>C3 Red cap</p> <p>C5 Yellow cap</p> | <p>Detent</p> <p>1 With detent</p> <p>2 Without detent</p> | <p>Mounting Style</p> <p>SS Panel with mounting ears</p> <p>MS PC thru-hole</p> <p>S2 Snap-in panel with blacktop plate</p> <p>TS Panel with mounting ears</p> | <p>Terminations</p> <p>03 Solder lug with hole</p> <p>02 PC Thru-hole</p> <p>04 PC Thru-hole</p> <p>07 Quick connect</p> <p>08 PC Thru-hole</p> <p>WC Wire lead</p> | <p>Housing Markings</p> <p>NONE No markings</p> <p>D ON-OFF</p> <p>L ON</p> <p>M ON-OFF</p> <p>N Red rectangle on one end</p> | <p>Contact Material</p> <p>Q Silver</p> <p>B Gold</p> <p>G Gold over silver</p> | <p>Seal</p> <p>NONE No seal</p> <p>E Epoxy seal</p> |
|---|---|---|---|--|---|---|--|



Dimensions are shown: Inch (mm)
Specifications and dimensions subject to change

S Series Slide Switches

SWITCH FUNCTION



| NO. POLES | MODEL NO. | AMP RATING | SWITCH FUNCTION | SCHEMATIC | AVAILABLE MOUNTING STYLES |
|-----------|-------------|------------|-----------------|-----------|---------------------------|
| SP | S101 | 6 | SPST | | SS |
| | S102 | 6 | SPDT | | MS,SS |
| | S112 | 6 | SPDT-MOM. | | MS,SS |
| | S701 | 15 | SPST | | S1,S2,S3,ST |
| | S702 | 15 | SPDT | | S1,S2,S3,ST |
| DP | S201 | 6 | DPST | | MS,SS,TS |
| | S202 | 6 | DPDT | | MS,SS,TS |
| | S602 | 12 | DPDT | | MS,SS,TS |
| | S802 | 15 | DPDT | | S1,S2,S3,ST |

SPST

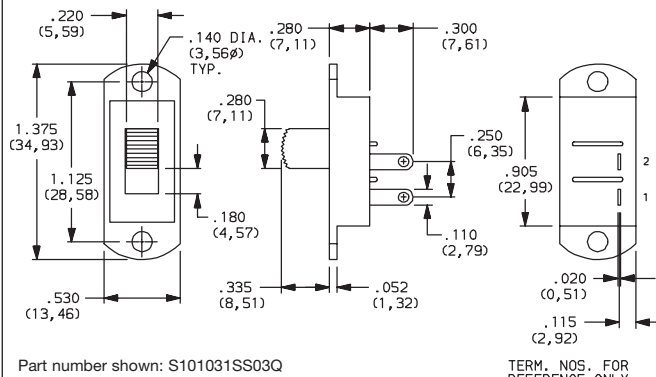

DPDT

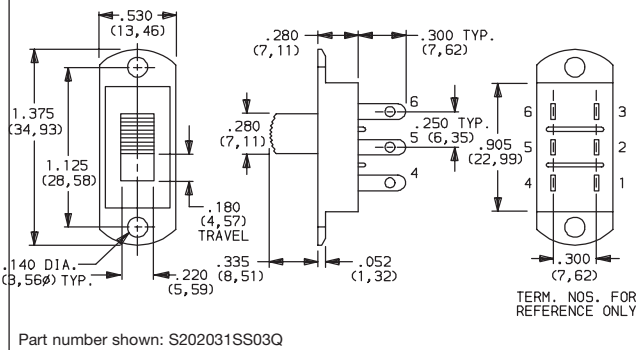

NOTE: and MOM. in table indicates momentary action.

All models with all options when ordered with 'G' or 'Q' contact material.

Contacts make on side actuator throw.

ACTUATOR



03 .335" HIGH

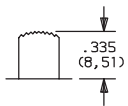

04 .500" HIGH

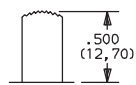

09 .250" HIGH

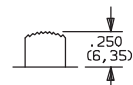

12 SCREWDRIVER SLOT (WITH MARKING)

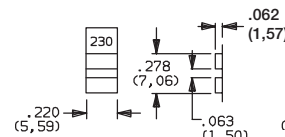

13 SCREWDRIVER SLOT (WITHOUT MARKING)

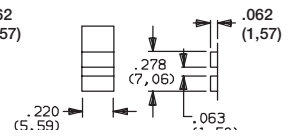

NOTE: Standard actuator color is black, other colors available, consult Customer Service Center. Alternate heights are available with '03, 04 and 09' actuators, consult Customer Service Center. Models with S2 mounting style, subtract .090 (2, 29). Actuators '12' and '13' are available with DPST and DPDT models only.

C2; C3; C5 SNAP-ON CAP

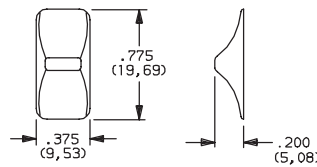

Available with S2 mounting style only.

| OPTION CODE2 | C1-CT CAP COLOR |
|--------------|-----------------|
| C2 | BLACK |
| C3 | RED |
| C5 | YELLOW |

NOTE: Actuator finish: matte. If no color is specified, black will be supplied. Colored actuator caps may also be ordered separately and user installed, see page I-32.

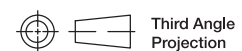

Third Angle Projection

Dimensions are shown: Inches (mm)
Specifications and dimensions subject to change



S Series Slide Switches

DETENT

- 1 WITH DETENT**
Standard with all maintained models: S101, S102, S201, S202, S602, S701, S702, and S802.
- 2 WITHOUT DETENT**
Standard with all momentary models: S112.

MOUNTING STYLE

SS PANEL WITH MOUNTING EARS

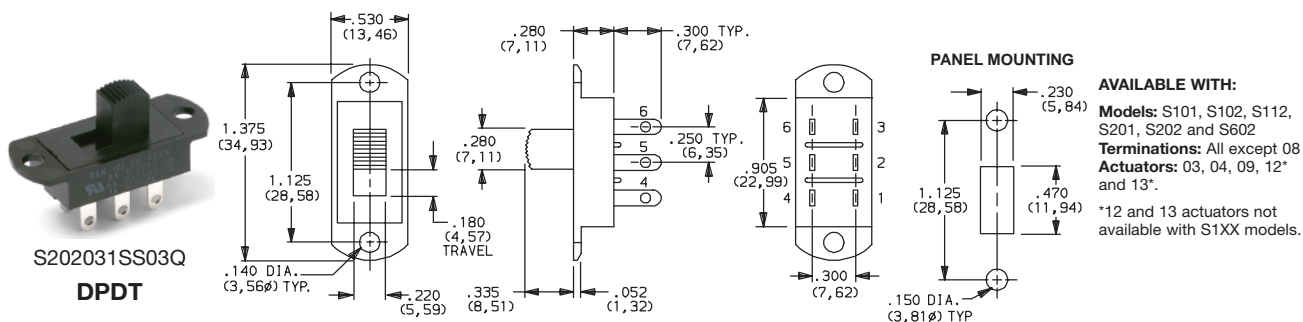

MS PC THRU-HOLE

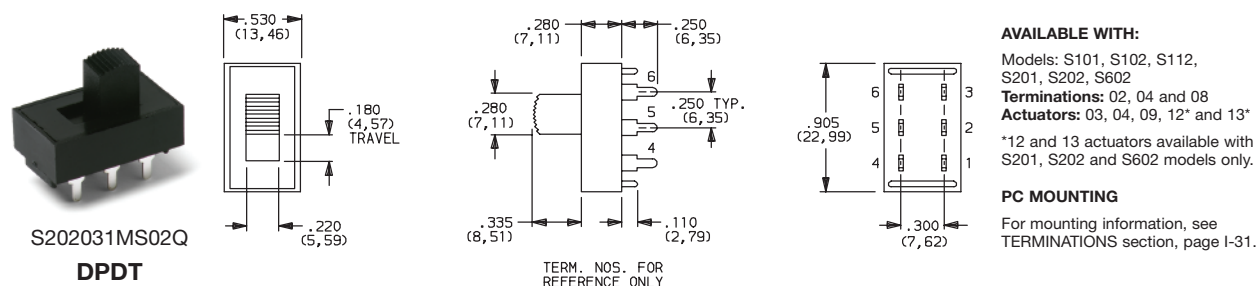

S2 SNAP-IN PANEL

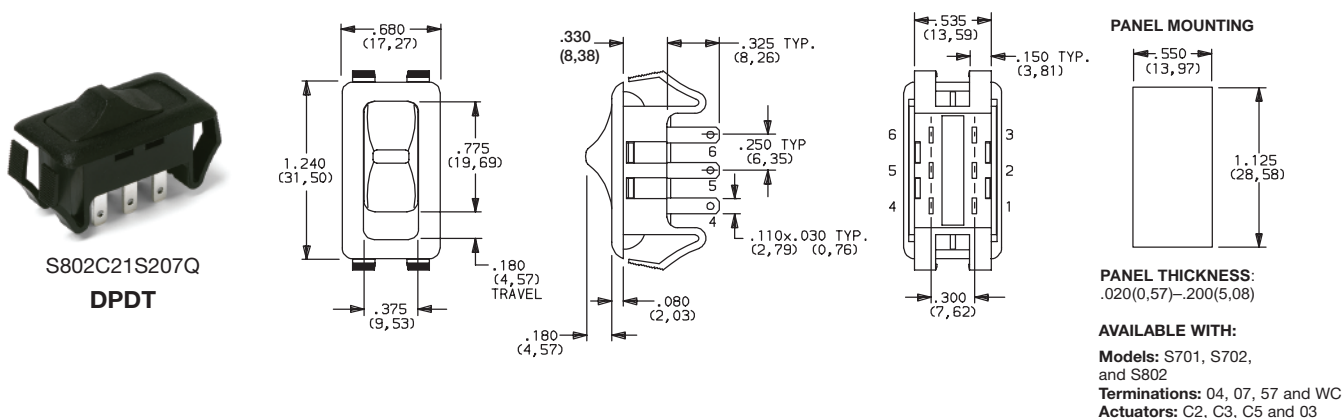

Dimensions are shown: Inch (mm)
 Specifications and dimensions subject to change



S Series Slide Switches

MOUNTING STYLE

TS PANEL WITH MOUNTING EARS

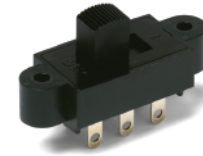
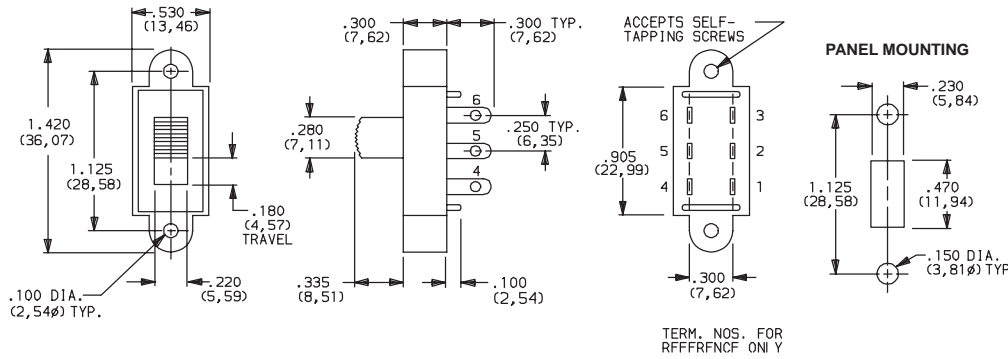

S202031TS03Q
DPDT

AVAILABLE WITH:
Models: S201, S202, and S602
Terminations: All
Actuators: 03, 04 and 12.

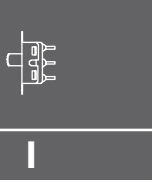

Slide

TERMINATIONS

03 SOLDER LUG WITH HOLE

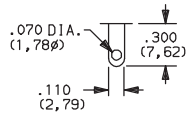

02 PC THRU-HOLE

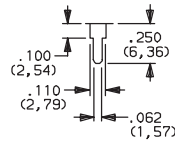

Recommended with 'MS' mounting style only.

04 PC THRU-HOLE

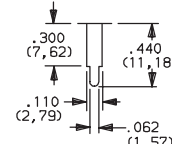

Recommended with double pole models only.

PC MOUNTING

02 & 04 terminations

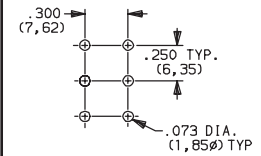

07 QUICK CONNECT

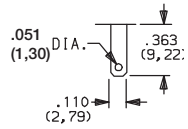

08 PC THRU-HOLE

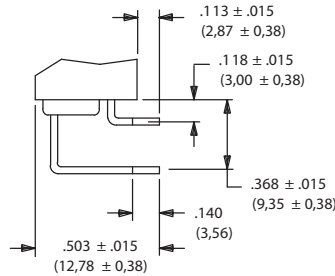

MS mounting style only.

WC WIRE LEAD

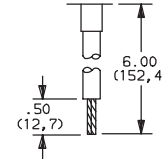

18 AWG wire for S1XX and S2XX models. 16 AWG wire for all other models. Black wire standard, other colors and lengths available, consult Customer Service Center. UL style 1015.

08 terminations with MS mounting style.

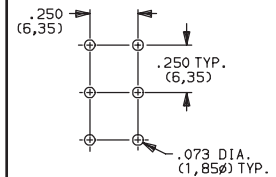

NOTE: All terminals on S1XX, S2XX and S6XX models are .020 (0,51) thick; all terminals on S7XX and S8XX models are .031 (0,79) thick.



Dimensions are shown: Inches (mm)
 Specifications and dimensions subject to change

S Series Slide Switches

TOP PLATE MARKINGS

NONE NO MARKINGS **D** ON-OFF **L** ON **M** ON-OFF **N** RED RECTANGLE ON ONE END

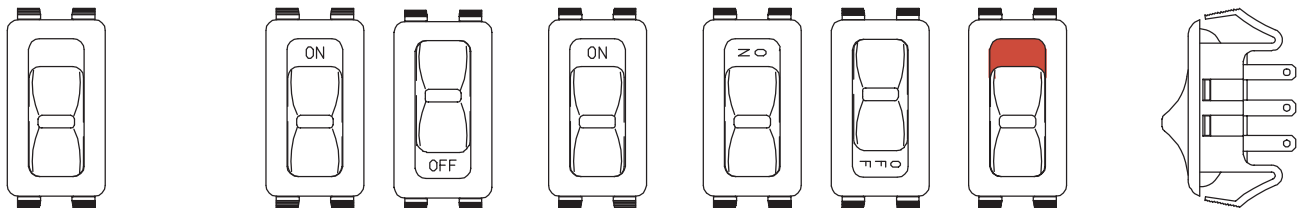

NOTE: Top plate markings are available with 'S2' mounting style only. The marking color on all top plates with marking options 'D, L and M' is white, standard. (except white top plates: marking color is black, standard). The marking color on all top plates with 'N' marking option is red, standard. Other marking colors are available, consult Customer Service Center.

Note: Orientation of actuator markings and terminals.

CONTACT MATERIAL

| OPTION CODE | CONTACT MATERIAL | RATINGS | |
|-------------|-------------------------------|--------------------------------|---|
| Q | SILVER ² | POWER | S1XX, S2XX MODELS: 6 AMPS @ 125 V AC; 6 AMPS @ 250 V AC; 1 AMP @ 125 V DC US S6XX MODELS: 12 AMPS @ 125 V AC; 6 AMPS @ 250 V AC; 1 AMP @ 125 V DC US S7XX, S8XX MODELS: 15 AMPS @ 125 V AC; 6 AMPS @ 250 V AC US |
| B | GOLD ¹ | LOW LEVEL/DRY CIRCUIT | 0.4 VA MAX. @20 V AC OR DC max. |
| G | GOLD OVER SILVER ³ | LOW LEVEL/DRY CIRCUIT OR POWER | S1XX, S2XX MODELS: 0.4 VA MAX. @ 20 V AC OR DC MAX. OR 6 AMPS @ 125 V AC; 6 AMPS @ 250 V AC; 1 AMP @ 125 V DC US S6XX MODELS: 0.4 VA MAX. @ 20 V AC OR DC MAX. OR 12 AMPS @ 125 V AC; 6 AMPS @ 250 V AC; 1 AMP @ 125 V DC US S7XX, S8XX MODELS: 0.4 VA MAX. @ 20 V AC OR DC MAX. OR 15 AMPS @ 125 V AC; 6 AMPS @ 250 V AC US |

* Note: See Technical Data section of this catalog for RoHS compliant and compatible definitions and specifications.

¹ CONTACTS & TERMINALS: Copper, with gold plate over nickel plate.

² CONTACTS & TERMINALS: Copper, silver plated (standard with all termination options).

³ CONTACTS & TERMINALS: Copper, with gold plate over nickel plate over silver plate.

NOTE: Any models supplied with Q, B or G contact material are RoHS compliant. All models US with all options when ordered with 'G' or 'Q' contact material.

NOTE: 'G' contact material is equivalent to both 'B' and 'Q' contact materials.

SEAL

NONE NO SEAL

E EPOXY SEAL

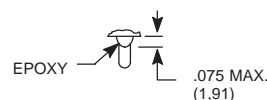

AVAILABLE HARDWARE

Cap, C2; C3 actuators

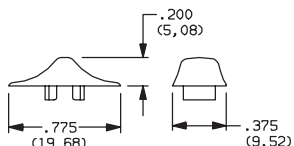

PART NO.

121160100 WHITE
121160200 BLACK
121160300 RED

Material: 6/6 Nylon
Finish: Matte

Cap, 03 actuator

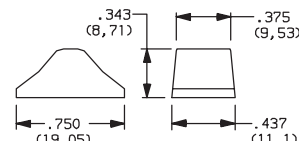

PART NO.

121000101 WHITE
121000102 BLACK
121000103 RED

Material: 6/6 Nylon
Finish: Gloss

NOTE: Other cap colors available, consult Customer Service Center.



Dimensions are shown: Inch (mm)
Specifications and dimensions subject to change



V Series Power & Line Voltage Select Slide Switches

Features/Benefits

- Ratings up to 10 AMPS
- Snap-in panel and PC mounting
- Actuators with screwdriver slot
- Quick connect terminals available
- RoHS compliant

Typical Applications

- Appliances

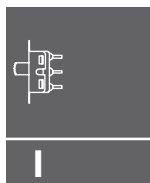

Side

Specifications

CONTACT RATING: 10 GPA @ 125 V AC 50/60 Hz T85;
5 GPA @ 250 V AC 50/60 Hz T85;
2 (0.5)A @ 250 VAC 50/60 Hz T85;
4RA @ 30 VDC T85

ELECTRICAL LIFE: 10,000 make-and-break cycles at full load.

CONTACT RESISTANCE: Below 10 m Ω typ. initial
@ 2-4 V DC, 100 mA.

INSULATION RESISTANCE: 10⁹ Ω min.

DIELECTRIC STRENGTH: 1,000 Vrms min. @ sea level.

OPERATING TEMPERATURE: -30°C to +85°C.

Materials

HOUSING: 6/6 nylon (UL94V-2), black.

TOP PLATE: 6/6 nylon (UL94V-2), black.

ACTUATOR: Glass filled polyester (UL94V-0), '01 and 02' styles, black (standard); '12, 13 and 14' styles, red (standard).

CONTACTS: Copper, silver plated.

TERMINALS: Copper, silver plated.

CONTACT SPRING: Music wire or stainless steel.

TERMINAL SEAL: Epoxy.

NOTE: Any models supplied with Q, B or G contact material are RoHS compliant.

NOTE: Specifications and materials listed above are for switches with standard options. For information on specific and custom switches, consult Customer Service Center.

Build-A-Switch

To order, simply select desired option from each category and place in the appropriate box. Available options are shown and described on pages I-34 through I-36. For additional options not shown in catalog, consult Customer Service Center.

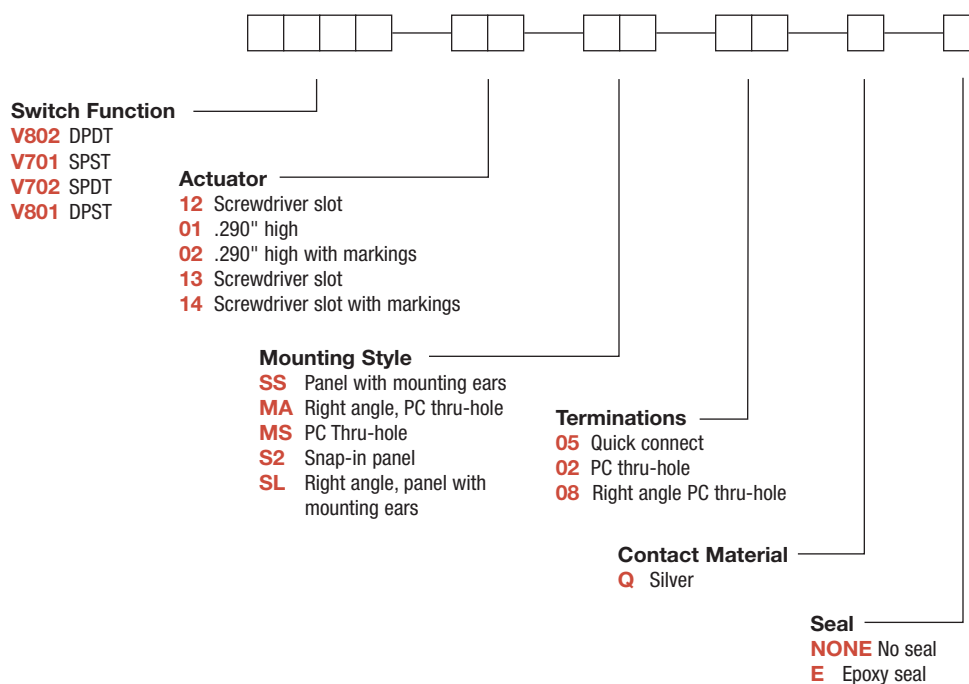

Dimensions are shown: Inches (mm)
Specifications and dimensions subject to change

V Series Power & Line Voltage Select Slide Switches

SWITCH FUNCTION

| NO. POLES | MODEL NO. | SWITCH FUNCTION | SCHEMATIC | AVAILABLE MOUNTING STYLES |
|-----------|-----------|-----------------|-----------|---------------------------|
| SP | V701 | SPST | | ALL |
| | V702 | SPDT | | ALL |

All models with all options.

Contacts make on side actuator throw.

| NO. POLES | MODEL NO. | SWITCH FUNCTION | SCHEMATIC | AVAILABLE MOUNTING STYLES |
|-----------|-----------|-----------------|-----------|---------------------------|
| DP | V801 | DPST | | ALL |
| | V802 | DPDT | | ALL |

ACTUATOR

12 SCREWDRIVER SLOT WITH MARKING

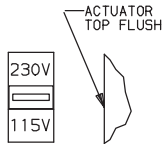

Actuator color is red with white 115V-230V markings (std.).

01 .290" HIGH

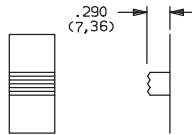

Actuator color is black.

02 .290" HIGH WITH MARKINGS

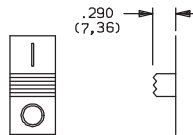

markings are reversed on V702 and V802 models. Actuator color is black with white markings (std.).

13 SCREWDRIVER SLOT NO MARKING

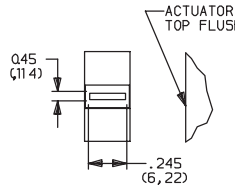

Actuator color is red.

14 SCREWDRIVER SLOT WITH MARKINGS

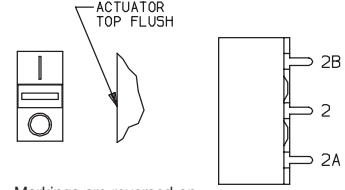

Markings are reversed on V702 and V802 models. Actuator color is red with white markings (std.). **Note:** Orientation of actuator markings and terminals.

MOUNTING STYLE

SS PANEL WITH MOUNTING EARS



V80212SS05Q
DPDT

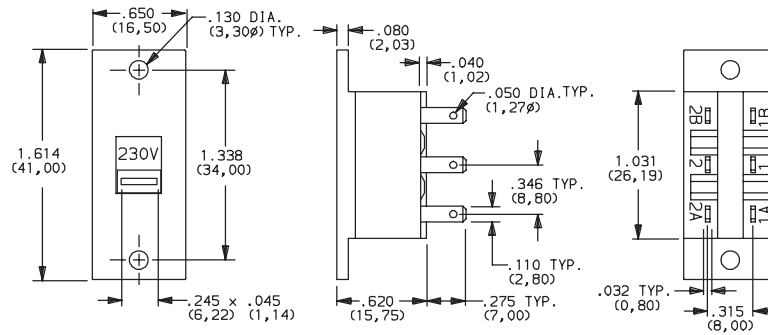

PANEL MOUNTING

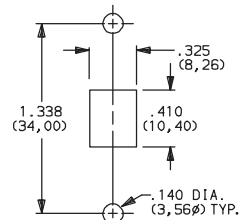

AVAILABLE WITH:
Models: All
Terminations: 02 and 05

MA RIGHT ANGLE, PC THRU-HOLE



V80212MA08Q
Horizontal Actuation
DPDT

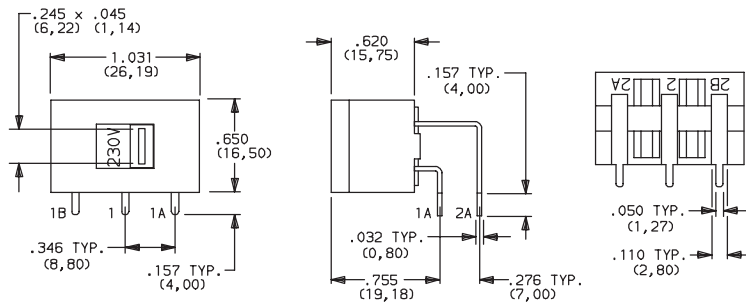

AVAILABLE WITH:

Models: All
Terminations: 08

PC MOUNTING

PC mount, side actuated.
For mounting information, see TERMINATIONS section, page I-36.



Third Angle Projection

Dimensions are shown: Inch (mm)
Specifications and dimensions subject to change



V Series Power & Line Voltage Select Slide Switches

MOUNTING STYLE

MS PC THRU-HOLE

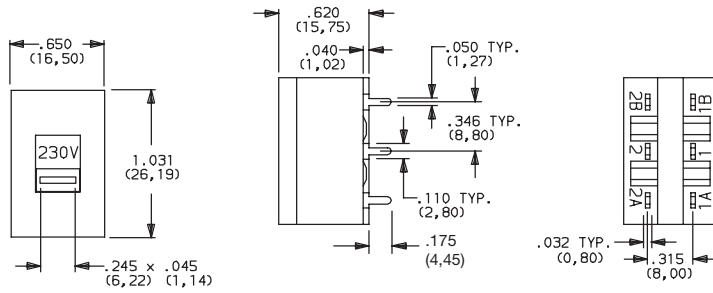

AVAILABLE WITH:
All models with 02 terminations

PC MOUNTING
PC mount, top actuated.
For mounting information,
see TERMINATIONS section, page I-36.



V80212MS02Q
DPDT

SL RIGHT ANGLE PANEL WITH MOUNTING EARS

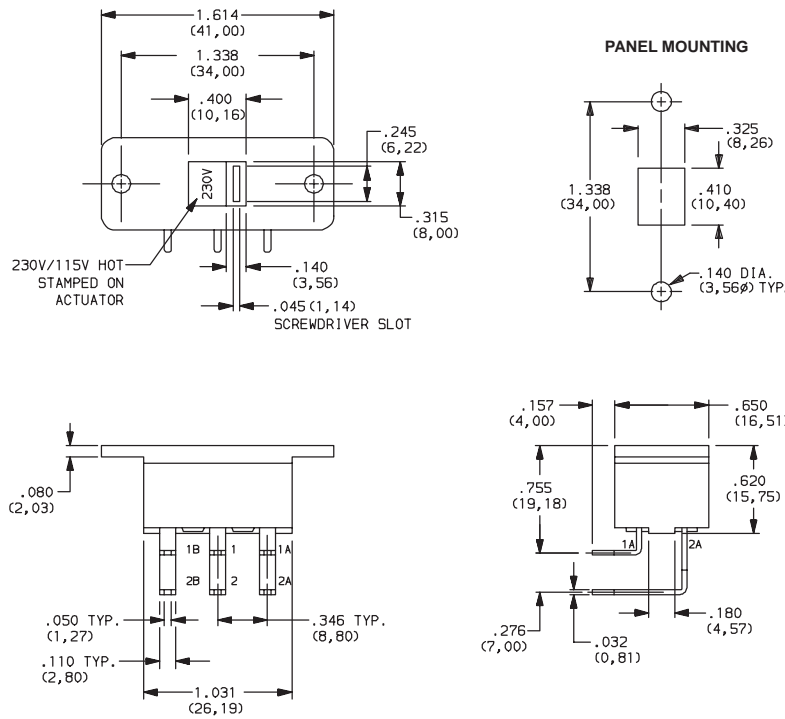

AVAILABLE WITH:
All models with 08 terminations



V80213SL08Q
Horizontal Actuation
DPDT

S2 SNAP-IN PANEL MOUNT

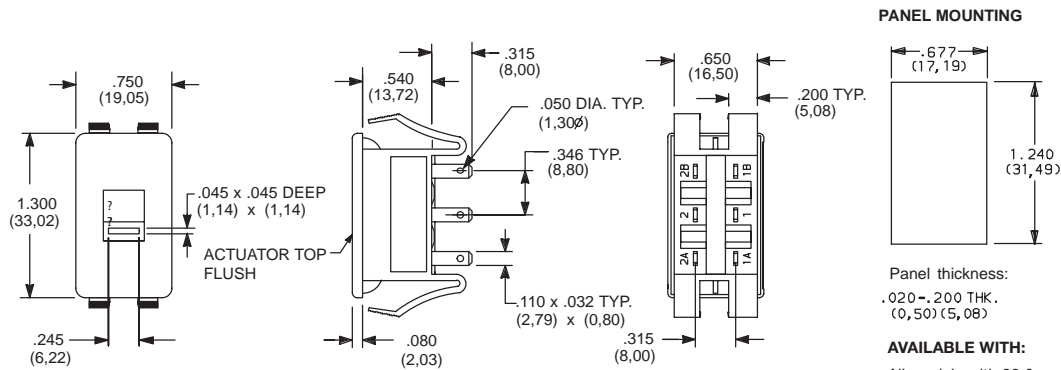

PANEL MOUNTING

Panel thickness:
.020-.200 THK.
(0,50) (5,08)

AVAILABLE WITH:
All models with 02 &
05 terminations



V80212S205Q
DPDT



Dimensions are shown: Inches (mm)
Specifications and dimensions subject to change



V Series Power & Line Voltage Select Slide Switches

TERMINATIONS

05 QUICK CONNECT

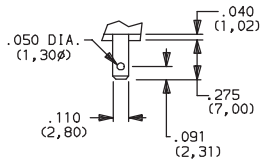

.032 THK.
(0,80)

Fits .110 in. quick connector.

02 PC THRU-HOLE

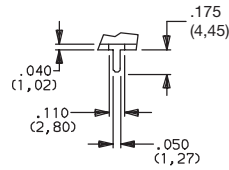

.032 THK.
(0,80)

PC MOUNTING

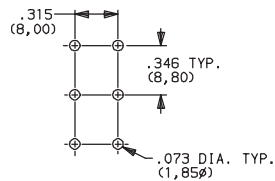

MS, SS Mounting Styles.

08 PC THRU-HOLE

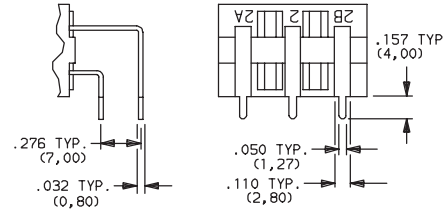

Not available with 'MS, SS or S2' mounting styles.

PC MOUNTING

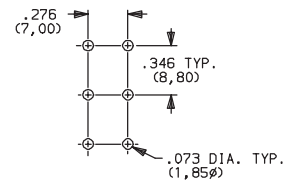

MA, SL Mounting Styles.

CONTACT MATERIAL

| OPTION CODE | CONTACT MATERIAL | RATINGS | |
|-------------|---------------------|---------|--|
| Q | SILVER ¹ | POWER | 10 GPA @ 125 V AC 50/60 Hz T85; 5 GPA @ 250 V AC 50/60 Hz T85; 2 (0.5)A @ 250 VAC 50/60 Hz T85; 4RA @ 30 VDC T85 |

* Note: See Technical Data section of this catalog for RoHS compliant and compatible definitions and specifications.

¹ CONTACTS & TERMINALS: Copper, silver plated (standard with all termination options).

All models   ¹⁵ with all options.

NOTE: Any models supplied with Q contact material are RoHS compliant.

SEAL

NONE NO SEAL

E EPOXY SEAL

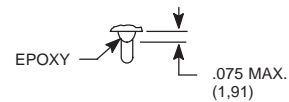

Dimensions are shown: Inch (mm)
Specifications and dimensions subject to change

OS Series Miniature Slide Switches

Features/Benefits

- Variety of actuators & terminations
- PC and panel mounting
- Shorting or non-shorting contacts
- RoHS compliant
- Halogen free material

Typical Applications

- Test & measurement equipment
- Computer peripherals & network products
- Consumer products

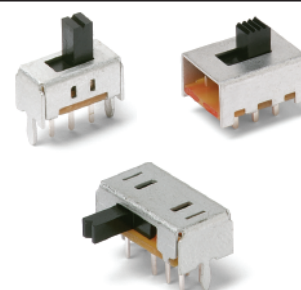

Specifications

CONTACT RATING: See individual parts.
 MECHANICAL & ELECTRICAL LIFE: 10,000 cycles.
 CONTACT RESISTANCE: 20 mΩ or less.
 INSULATION RESISTANCE: 100 MΩ min. at 500 VDC.
 DIELECTRIC STRENGTH: 500 VAC for 1 minute.
 OPERATING TEMPERATURE: -30°C to +70°C.
 PACKAGING: Bulk

* For RoHS compatible switches contact customer service.

Materials

BASE: Phenolic resin.
 ACTUATOR: Standard: POM, Black.
 High Temperature Option: PA46, Black.
 HOUSING PLATE: Non-compatible; SPCC Sn plated.
 Compatible; SPCC Ni plated.
 MOVABLE CONTACT: Copper alloy, silver plated.
 STATIONARY CONTACTS: Brass, silver plated.
 TERMINALS: Brass, silver plated.
 TERMINAL SEALED.

NOTE: Specifications and materials listed above are for switches with standard options. For information on specific and custom switches, consult Customer Service Center.

How To Order

Complete part numbers for OS Series Slide Switches are shown on pages I-37 through I-43.

| PART NUMBER | | | SWITCH FUNCTION | |
|---|----------------|-----------------|-----------------|-------|
| | RoHS Compliant | RoHS Compatible | POS.1 | POS.2 |
| OS102011MS2QN1 (non-shorting) | YES | NO | ON | ON |
| OS102011MS2QN1C* (non-shorting) | YES | YES | ON | ON |
| OS102011MS2QS1 (shorting) | YES | NO | ON | ON |
| OS102011MS2QS1C* (shorting) | YES | YES | ON | ON |
| CONN. TERMINALS | | | 1-2 | 2-3 |
| SCHMATIC | | | | |
| SPDT | | | | |

CONTACT RATING: 0.1A @ 12 VDC

* "C" option at the end of part number designates high temperature actuators

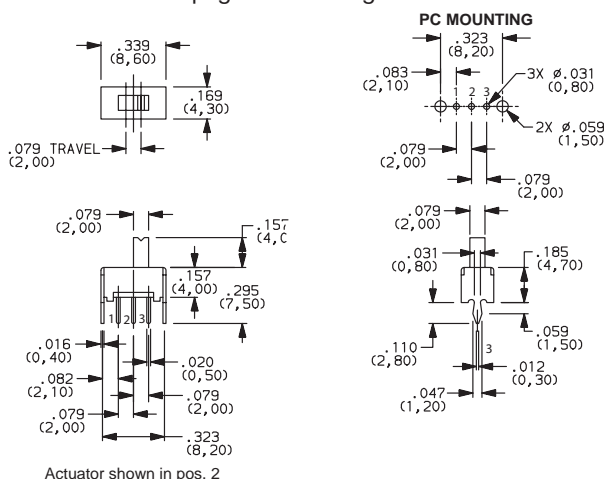

Actuator shown in pos. 2



OS102011MS2QN1
SPDT

| PART NUMBER | | | SWITCH FUNCTION | | |
|--|----------------|-----------------|-----------------|-------|-------|
| | ROHS Compliant | ROHS Compatible | POS.1 | POS.2 | POS.3 |
| OS103011MS8QP1 (Non-specified) | YES | NO | ON | ON | ON |
| OS103011MS8QP1C* (Non-specified) | YES | YES | ON | ON | ON |
| CONN. TERMINALS | | | 1-2 | 2-3 | 2-4 |
| SCHMATIC | | | | | |
| SP3T | | | | | |

CONTACT RATING: 0.1A @ 12 VDC

* "C" option at the end of part number designates high temperature actuators

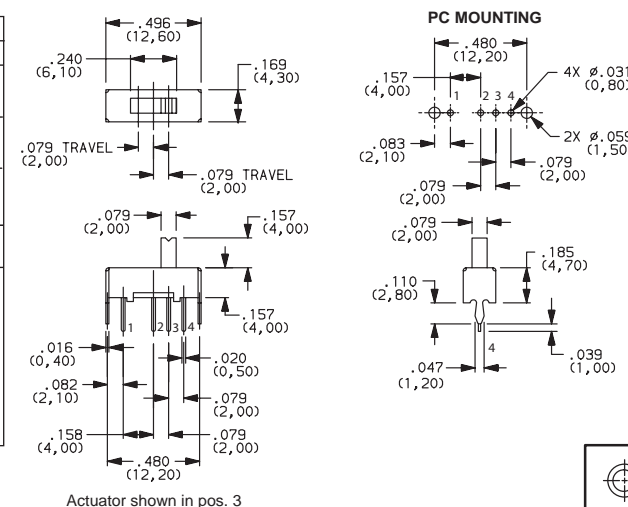

Actuator shown in pos. 3

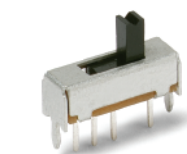

OS103011MS8QP1
SP3T



Third Angle Projection

Dimensions are shown: Inches (mm)
 Specifications and dimensions subject to change



8 aug 17

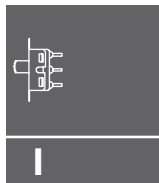

Slide

OS Series Miniature Slide Switches

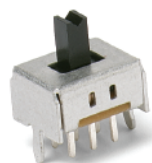

OS202011MS2QS1
DPDT

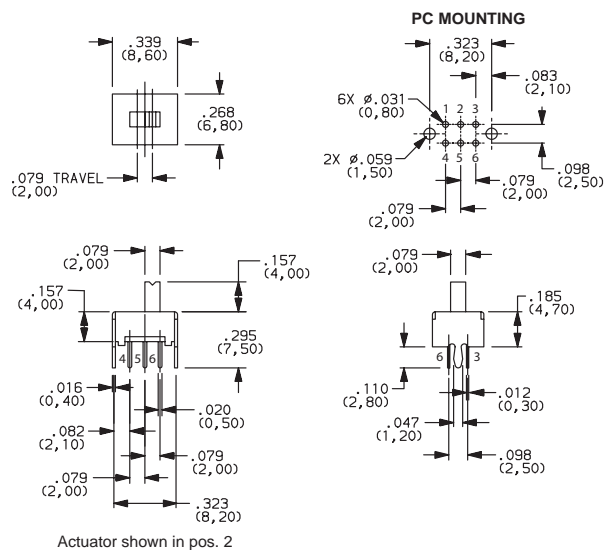

| PART NUMBER | RoHS Compliant | RoHS Compatible | SWITCH FUNCTION | |
|-------------------------------|----------------|-----------------|-----------------|----------|
| | | | POS.1 | POS.2 |
| OS202011MS2QS1 (Shorting) | YES | NO | ON | ON |
| OS202011MS2QN1 (Non-shorting) | YES | NO | ON | ON |
| CONN. TERMINALS | | | 1-2, 4-5 | 2-3, 5-6 |
| SCHEMATIC | | | | |
| DPDT | | | | |

CONTACT RATING: 0.1A @ 12 VDC

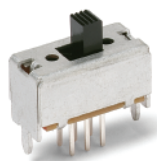

OS203011MS1QP1
DP3T

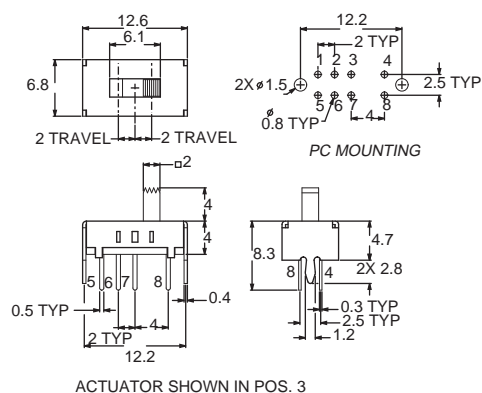

| PART NUMBER | ROHS Compliant | ROHS Compatible | SWITCH FUNCTION | | |
|--------------------------------|----------------|-----------------|-----------------|----------|----------|
| | | | POS.1 | POS.2 | POS.3 |
| OS203011MS1QP1 (Non-specified) | YES | NO | ON | ON | ON |
| CONN. TERMINALS | | | 1-3, 5-7 | 2-3, 6-7 | 3-4, 7-8 |
| SCHEMATIC | | | | | |
| DP3T | | | | | |

CONTACT RATING: 0.3A @ 30 VDC

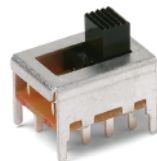

OS202013MT5QN1
DPDT

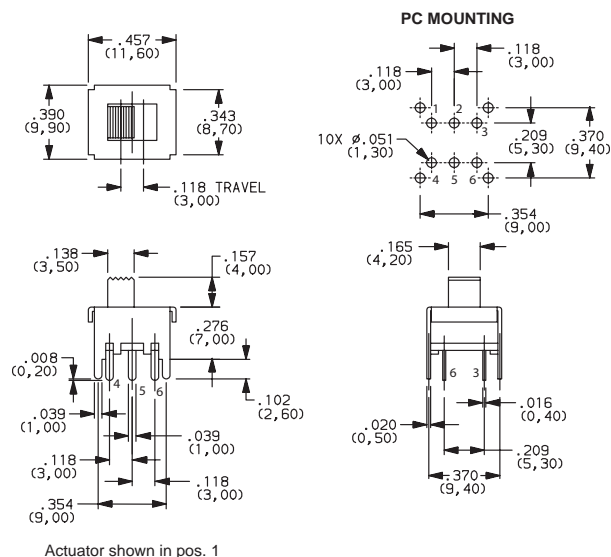

| PART NUMBER | RoHS Compliant | RoHS Compatible | SWITCH FUNCTION | |
|-------------------------------|----------------|-----------------|-----------------|----------|
| | | | POS.1 | POS.2 |
| OS202013MT5QN1 (Non-shorting) | YES | NO | ON | ON |
| CONN. TERMINALS | | | 1-2, 4-5 | 2-3, 5-6 |
| SCHEMATIC | | | | |
| DPDT | | | | |

CONTACT RATING: 0.3A @ 30 VDC

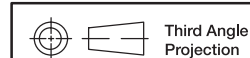

Third Angle Projection

Dimensions are shown: Inch (mm)
Specifications and dimensions subject to change



OS Series Miniature Slide Switches

| PART NUMBER | ROHS | | SWITCH FUNCTION | | |
|---|-----------|------------|-----------------|-------|----------|
| | Compliant | Compatible | POS.1 | POS.2 | POS.3 |
| OS203013MT7QN1 (Non-shorting) | YES | NO | ON | OFF | ON |
| CONN. TERMINALS | | | 1-2, 4-5 | | 2-3, 5-6 |
| SCHEMATIC | | | | | |
| | | | | | |
| DP3T | | | | | |

CONTACT RATING: 0.3A @ 30 VDC

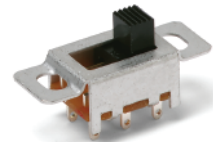
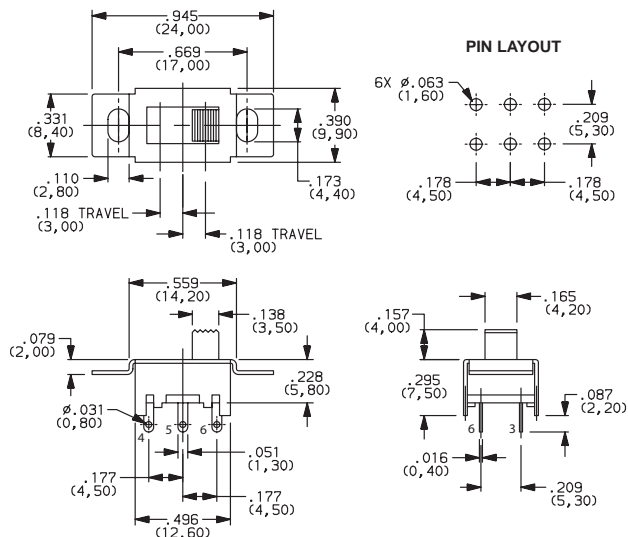

OS203013MT7QN1
DP3T

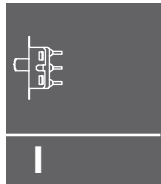

Slide

| PART NUMBER | ROHS | | SWITCH FUNCTION | |
|---|-----------|------------|-----------------|----------|
| | Compliant | Compatible | POS.1 | POS.2 |
| OS202013MT8QN1 (Non-shorting) | YES | NO | ON | ON |
| CONN. TERMINALS | | | 1-2, 4-5 | 2-3, 5-6 |
| SCHEMATIC | | | | |
| | | | | |
| DPDT | | | | |

CONTACT RATING: 0.3A @ 30 VDC

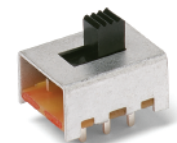
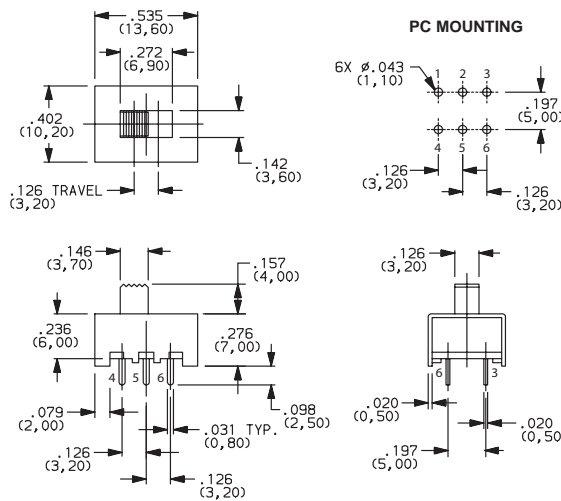

OS202013MT8QN1
DPDT

| PART NUMBER | ROHS | | SWITCH FUNCTION | | |
|---|-----------|------------|-----------------|----------|----------|
| | Compliant | Compatible | POS.1 | POS.2 | POS.3 |
| OS203013MT8QN1 (Non-shorting) | YES | NO | ON | ON | ON |
| CONN. TERMINALS | | | 1-2, 5-6 | 2-3, 6-7 | 3-4, 7-8 |
| SCHEMATIC | | | | | |
| | | | | | |
| DP3T | | | | | |

CONTACT RATING: 0.3A @ 30 VDC

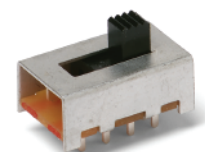
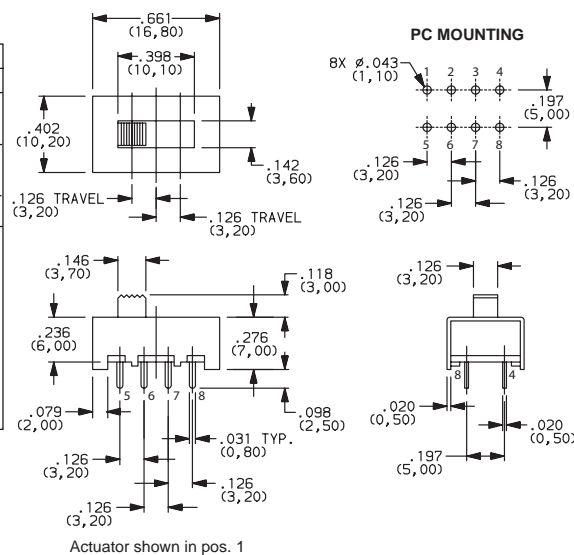

OS203013MT8QN1
DP3T

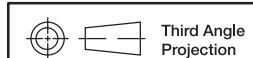

Dimensions are shown: Inches (mm)
Specifications and dimensions subject to change



8 aug 17

OS Series Miniature Slide Switches

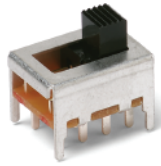

OS203013MT6QN1
DP3T

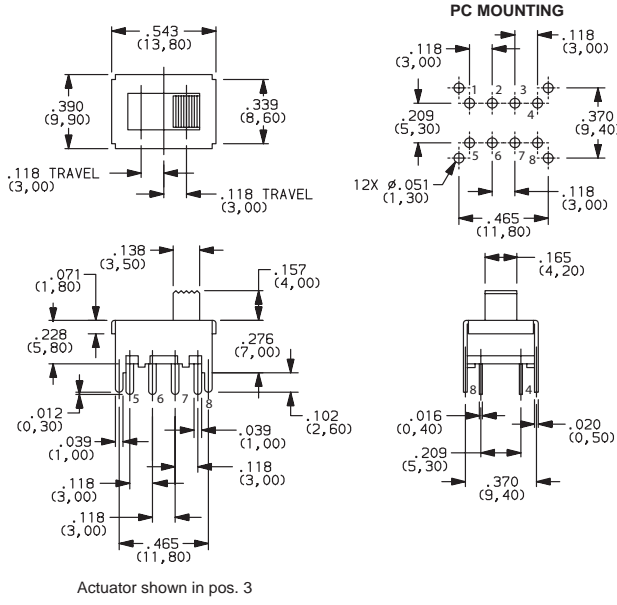

| PART NUMBER | ROHS Compliant | ROHS Compatible | SWITCH FUNCTION | | |
|----------------------------------|----------------|-----------------|-----------------|----------|----------|
| | | | POS.1 | POS.2 | POS.3 |
| OS203013MT6QN1 (Non-shorting) | YES | NO | ON | ON | ON |
| CONN. TERMINALS | | | 1-2, 5-6 | 2-3, 6-7 | 3-4, 7-8 |
| SCHEMATIC | | | | | |
| | | | | | |
| DP3T | | | | | |

CONTACT RATING: 0.2A @ 30 VDC



OS103012MU1QP1
SP3T

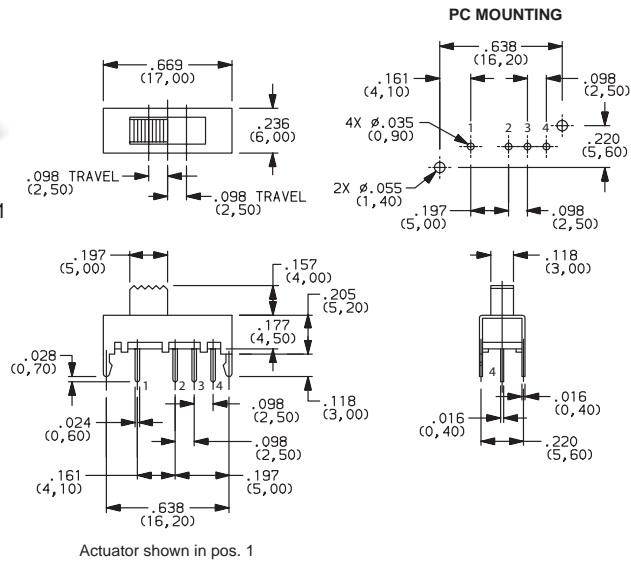

| PART NUMBER | ROHS Compliant | ROHS Compatible | SWITCH FUNCTION | | |
|----------------------------------|----------------|-----------------|-----------------|-------|-------|
| | | | POS.1 | POS.2 | POS.3 |
| OS103012MU1QP1 (Non-shorting) | YES | NO | ON | ON | ON |
| CONN. TERMINALS | | | 1-2 | 2-3 | 2-4 |
| SCHEMATIC | | | | | |
| | | | | | |
| SP3T | | | | | |

CONTACT RATING: 0.2A @ 30 VDC

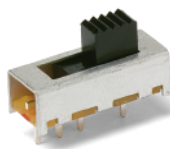

OS103012MU2QP1
SP3T

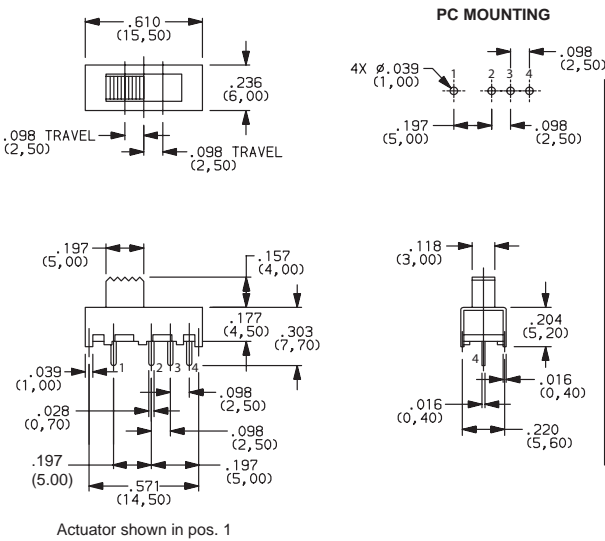

| PART NUMBER | ROHS Compliant | ROHS Compatible | SWITCH FUNCTION | | |
|----------------------------------|----------------|-----------------|-----------------|-------|-------|
| | | | POS.1 | POS.2 | POS.3 |
| OS103012MU2QP1 (Non-shorting) | YES | NO | ON | ON | ON |
| CONN. TERMINALS | | | 1-2 | 2-3 | 2-4 |
| SCHEMATIC | | | | | |
| | | | | | |
| SP3T | | | | | |

CONTACT RATING: 0.2A @ 30 VDC

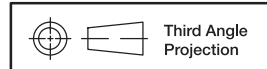

Dimensions are shown: Inch (mm)
Specifications and dimensions subject to change



Slide

OS Series Miniature Slide Switches

| PART NUMBER | ROHS Compliant | ROHS Compatible | SWITCH FUNCTION | | |
|--|----------------|-----------------|-----------------|----------|----------|
| | | | POS.1 | POS.2 | POS.3 |
| OS203012MU5QP1 (Non-specified) | YES | NO | ON | ON | ON |
| CONN. TERMINALS | | | 1-2, 5-6 | 2-3, 6-7 | 2-4, 6-8 |
| SCHEMATIC | | | | | |
| | | | | | |
| DP3T | | | | | |

CONTACT RATING: 0.1A @ 30 VDC

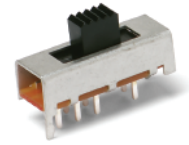
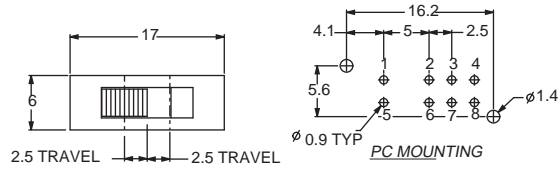

OS203012MU5QP1
DP3T

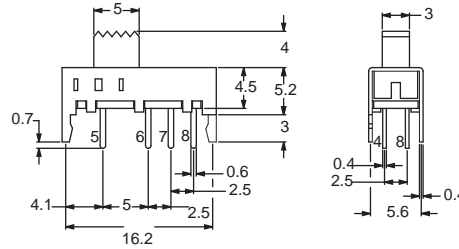

ACTUATOR SHOWN IN POS. 1

| PART NUMBER | RoHS Compliant | RoHS Compatible | SWITCH FUNCTION | |
|---|----------------|-----------------|-----------------|----------|
| | | | POS.1 | POS.2 |
| OS202011MV4QN1 (Non-shorting) | YES | NO | ON | ON |
| OS202011MV4QS1 (Shorting) | YES | NO | ON | ON |
| CONN. TERMINALS | | | 1-2, 4-5 | 2-3, 5-6 |
| SCHEMATIC | | | | |
| | | | | |
| DPDT | | | | |

CONTACT RATING: 0.1A @ 30 VDC

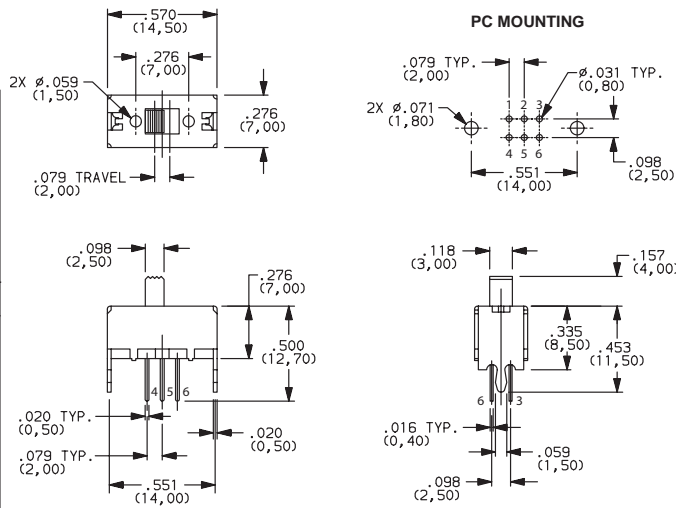

Actuator shown in pos. 1

OS202011MV4QN1
DPDT

| PART NUMBER | ROHS Compliant | ROHS Compatible | SWITCH FUNCTION | | |
|---|----------------|-----------------|-----------------|-----------------|-----------------|
| | | | POS.1 | POS.2 | POS.3 |
| OS203011MV9QS1 (Shorting) | YES | NO | ON | ON | ON |
| OS203011MV9QN1 (Non-Shorting) | YES | NO | ON | ON | ON |
| CONN. TERMINALS | | | 1-2-5 6-7-10 | 1-3-5 6-8-10 | 1-4-5 6-9-10 |
| SCHEMATIC | | | | | |
| | | | | | |
| DP3T | | | | | |

CONTACT RATING: 0.1A @ 30 VDC

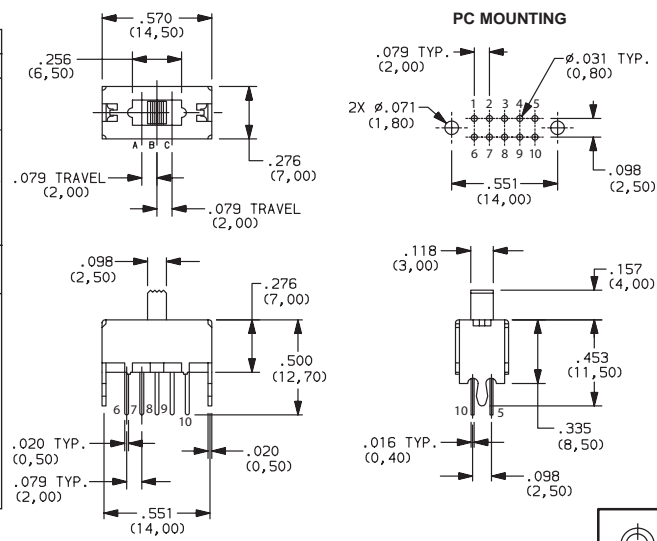

Actuator shown in pos. 2(A)

OS203011MV9QS1
DP3T

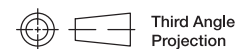

Third Angle Projection

Dimensions are shown: Inches (mm)
Specifications and dimensions subject to change



8 aug 17



OS Series Miniature Slide Switches

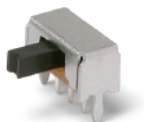

OS102011MA1QN1
SPDT

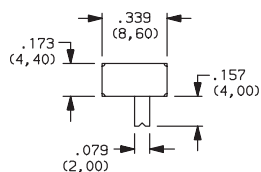

PC MOUNTING

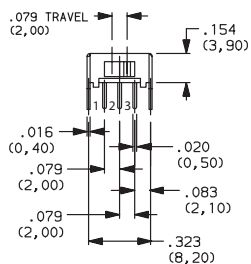
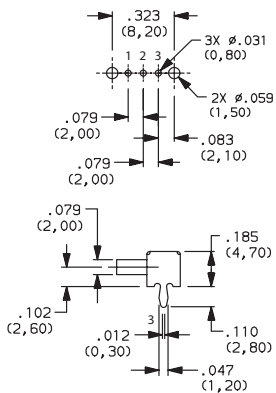

Actuator shown in pos. 2

| PART NUMBER | SWITCH FUNCTION | | POS.1 | POS.2 |
|------------------------------------|-----------------|-----------------|-------|-------|
| | RoHS Compliant | RoHS Compatible | | |
| OS102011MA1QN1 (Non-shorting) | YES | NO | ON | ON |
| OS102011MA1QN1C* (Non-shorting) | YES | YES | ON | ON |
| OS102011MA1QS1 (Shorting) | YES | NO | ON | ON |
| OS102011MA1QS1C* (Shorting) | YES | YES | ON | ON |
| CONN. TERMINALS | | | 1-2 | 2-3 |
| SCHEMATIC | | | | |
| | | | | |
| SPDT | | | | |

CONTACT RATING: 0.1A @ 12 VDC

* "C" option at the end of part number designates high temperature actuators

Slide



OS103011MA7QP1
SP3T

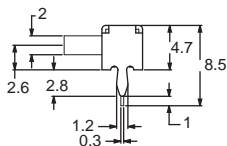
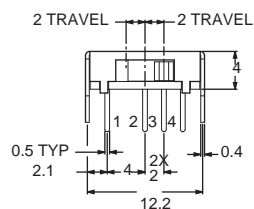
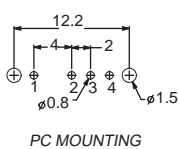
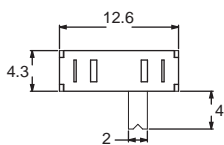

| PART NUMBER | SWITCH FUNCTION | | | | |
|-------------------------------------|-----------------|-----------------|-------|-------|-------|
| | ROHS Compliant | ROHS Compatible | POS.1 | POS.2 | POS.3 |
| OS103011MA7QP1 (Non-specified) | YES | NO | ON | ON | ON |
| OS103011MA7QP1C* (Non-specified) | YES | YES | ON | ON | ON |
| CONN. TERMINALS | | | 1-2 | 2-3 | 2-4 |
| SCHEMATIC | | | | | |
| | | | | | |
| SP3T | | | | | |

CONTACT RATING: 0.1A @ 12 VDC

* "C" option at the end of part number designates high temperature actuators



OS203011MA2QP1
DP3T

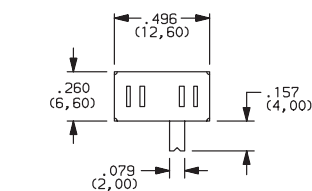

PC MOUNTING

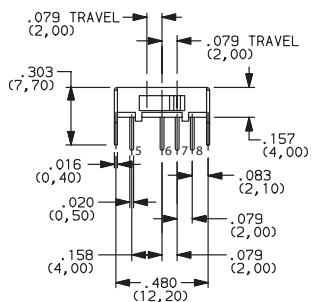
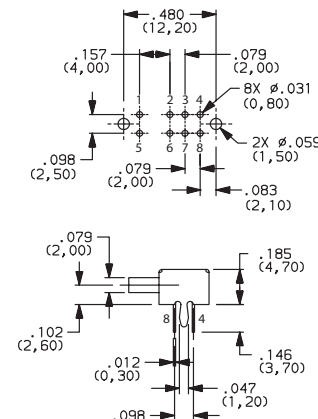

Actuator shown in pos. 3

| PART NUMBER | SWITCH FUNCTION | | | | |
|-----------------------------------|-----------------|-----------------|----------|----------|----------|
| | ROHS Compliant | ROHS Compatible | POS.1 | POS.2 | POS.3 |
| OS203011MA2QP1 (Non-specified) | YES | NO | ON | ON | ON |
| CONN. TERMINALS | | | 1-2, 5-6 | 2-3, 6-7 | 2-4, 6-8 |
| SCHEMATIC | | | | | |
| | | | | | |
| DP3T | | | | | |

CONTACT RATING: 0.1A @ 12 VDC



Third Angle Projection

Dimensions are shown: Inch (mm)
Specifications and dimensions subject to change



8 aug 17

OS Series Miniature Slide Switches

| PART NUMBER | RoHS Compliant | RoHS Compatible | SWITCH FUNCTION | |
|---|-------------------|--------------------|-----------------|----------|
| | | | POS.1 | POS.2 |
| OS202011MA0QN1 (Non-shorting) | YES | NO | ON | ON |
| OS202011MA0QS1 (Shorting) | YES | NO | ON | ON |
| CONN. TERMINALS | | | 1-2, 4-5 | 2-3, 5-6 |
| SCHEMATIC | | | | |
| | | | | |
| DPDT | | | | |

CONTACT RATING: 0.1A @ 12 VDC

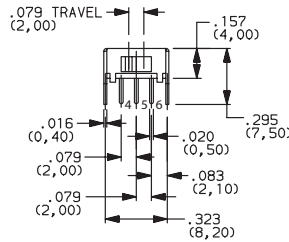
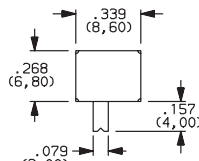

Actuator shown in pos. 1

PC MOUNTING

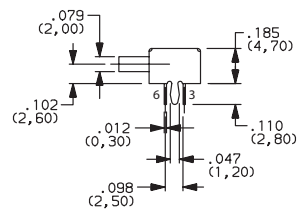
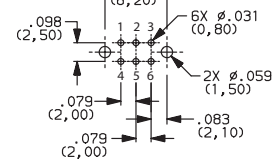

OS202011MA0QN1
DPDT

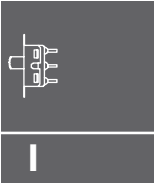

Slide

PCM Series Ultraminiature Surface Mount Slide Switches



Features/Benefits

- Ultraminiature surface mount
- Low profile
- SPDT & SP3T models
- RoHS compliant

Typical Applications

- Computer peripherals & network products
- Telecommunication products
- Test & measurement equipment

Specifications

CONTACT RATING: 0.3A @ 6 VDC.
 MECHANICAL LIFE: 10,000 cycles.
 CONTACT RESISTANCE: 70 m Ω max.
 INSULATION RESISTANCE: 100 M Ω min. @ 500V.
 DIELECTRIC STRENGTH: 500 VAC min.
 OPERATING TEMPERATURE: -20°C to +85°C.
 SOLDERABILITY: 255C max. solder temperature.
 PACKAGING: Tape & reel.

Materials

CASE: PA6T
 COVER: Stainless steel.
 SLIDER: Nylon 4/6
 BRUSH: Copper alloy silver clad.
 TERMINALS: Copper alloy, silver plated.

NOTE: All models RoHS compliant and compatible with all options.

NOTE: Specifications and materials listed above are for switches with standard options. For information on specific and custom switches, consult Customer Service Center.

How To Order

Complete part numbers for PCM Series Ultraminiature Surface Mount Slide Switches are shown below and on page I-45.

PC MOUNTING

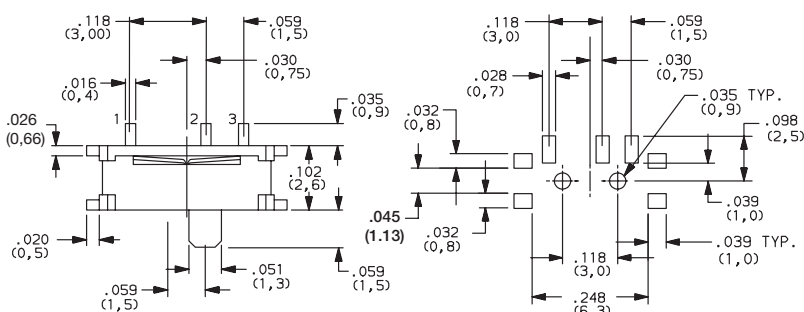

PCM12SMTR
SPDT

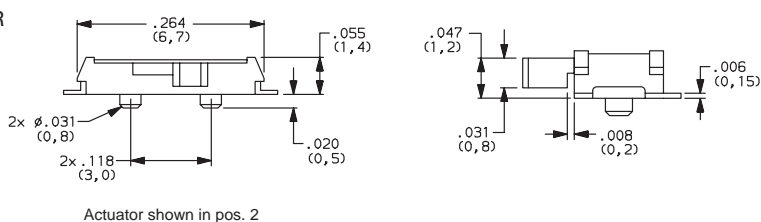

| PART NUMBER | SWITCH FUNCTION | |
|------------------|-----------------|--------|
| | POS. 1 | POS. 2 |
| PCM12SMTR | ON | ON |
| CONN. TERMINALS | 1-2 | 2-3 |
| SCHEMATIC | | |
| SPDT | | |

TAPE & REEL

For part number PCM12SMTR

Quantity per reel 3500

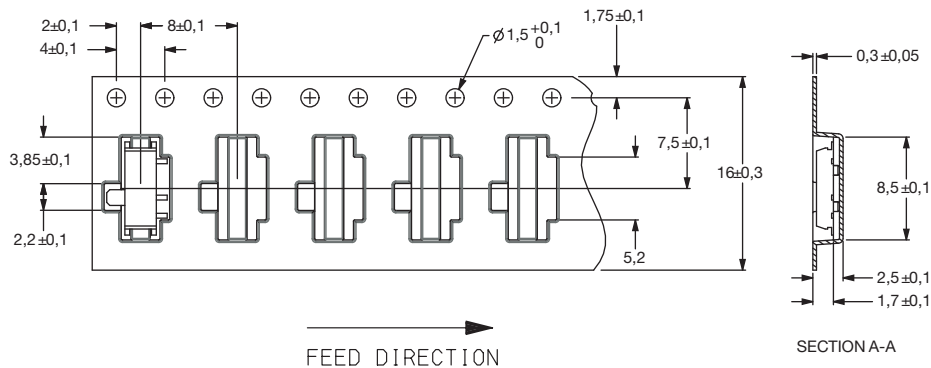

Dimensions are shown: Inch (mm)
 Specifications and dimensions subject to change

PCM Series Ultraminiature Surface Mount Slide Switches

| PART NUMBER | SWITCH FUNCTION | | |
|------------------|-----------------|--------|--------|
| | POS. 1 | POS. 2 | POS. 3 |
| PCM13SMTR | ON | ON | ON |
| CONN. TERMINALS | 1-3 | 2-3 | 3-4 |
| SCHEMATIC | | | |
| SP3T | | | |

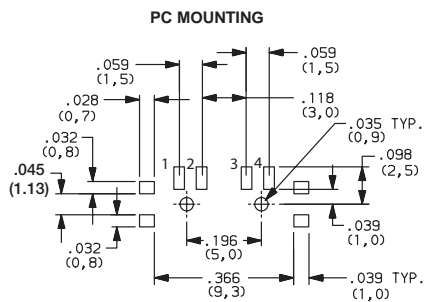
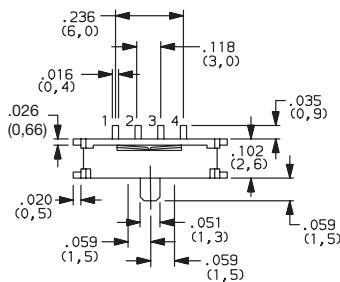

PCM13SMTR
SP3T

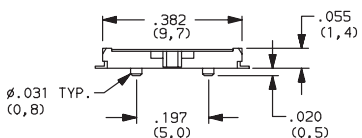

Actuator shown in pos. 2

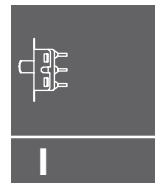
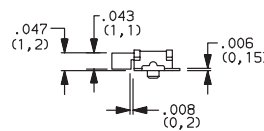

Slide

TAPE & REEL

For part number PCM13SMTR

Quantity per reel 3500

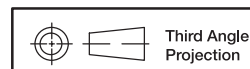
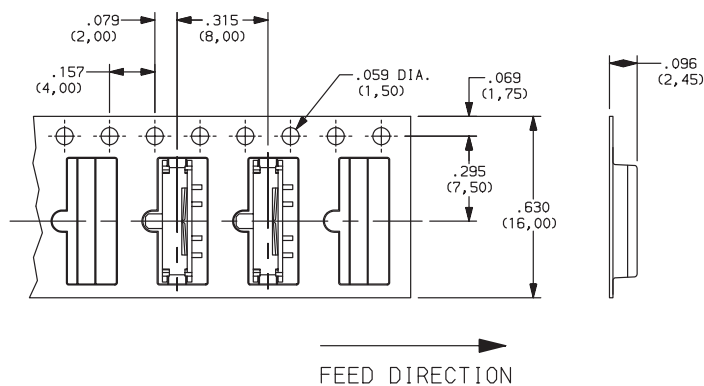

Third Angle
Projection
Dimensions are shown: Inches (mm)
Specifications and dimensions subject to change

AYZ Series Miniature Slide Switches



Features/Benefits

- Low profile
- Single & double pole models
- Double & triple throw models
- RoHS compatible

Typical Applications

- Computer peripherals & network products
- Telecommunication products
- Test & measurement equipment

Specifications

MAX. SWITCHING POWER: 1.2 VA
 MAX. SWITCHING VOLTAGE: 12 VDC
 MAX. SWITCHING CURRENT: 100 mA
 MECHANICAL LIFE: 10,000 operations.
 CONTACT RESISTANCE: <math><80\text{m}\Omega</math>
 INSULATION RESISTANCE: >10 Ω
 DIELECTRIC STRENGTH: 0.1 kV at 50 Hz/1 min.
 OPERATING TEMPERATURE: -10°C to +60°C
 PACKAGING: Tape & reel, see page I-47.

Materials

HOUSING: Glass filled nylon 4/6 (UL 94V-0).
 ACTUATOR: Glass filled nylon 6/6 (UL 94V-0), except options ending in C which are glass filled nylon 4/6 (UL94V-0).
 COVER: Nickel silver.
 MOVABLE CONTACT: Copper alloy, silver plated.
 FIXED CONTACT: Brass, silver plated.
 CONTACT SPRING: Contact bronze.

NOTE: Specifications and materials listed above are for switches with standard options. For information on specific and custom switches, consult Customer Service Center.

How To Order

Complete part numbers for AYZ Series Miniature Slide Switches are shown on pages I-46 through I-48.

PC MOUNTING

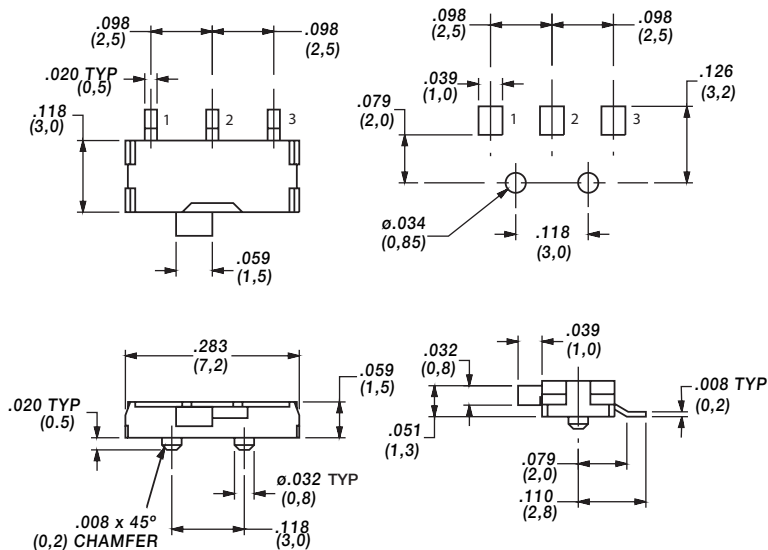

SWITCH SHOWN IN POSITION 1

| PART NUMBER | RoHS | | SWITCH FUNCTION | |
|---------------------|-----------|------------|-----------------|-------|
| | Compliant | Compatible | POS.1 | POS.2 |
| AYZ0102AGRLC | YES | YES | | |
| CONN. TERMINALS | | | 1-2 | 2-3 |
| SCHEMATIC | | | | |
| | | | | |
| SPDT | | | | |



Dimensions are shown: Inch (mm)
 Specifications and dimensions subject to change



Slide

AYZ Series Miniature Slide Switches

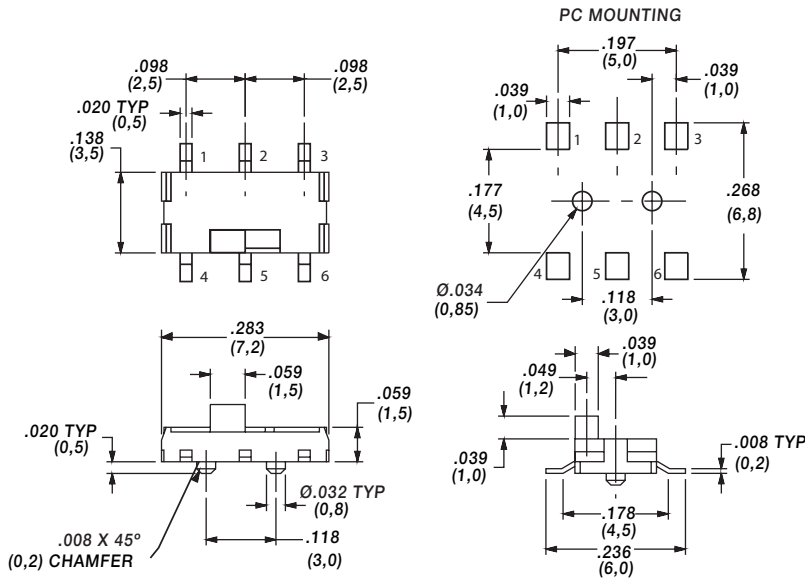

| PART NUMBER | RoHS | | SWITCH FUNCTION | |
|---------------------|-----------|------------|-----------------|---------|
| | Compliant | Compatible | POS.1 | POS.2 |
| AYZ0202AGRLC | YES | YES | ON | ON |
| CONN. TERMINALS | | | 1-2,4-5 | 2-3,5-6 |
| SCHEMATIC | | | | |
| DPDT | | | | |

SWITCH SHOWN IN POSITION 1

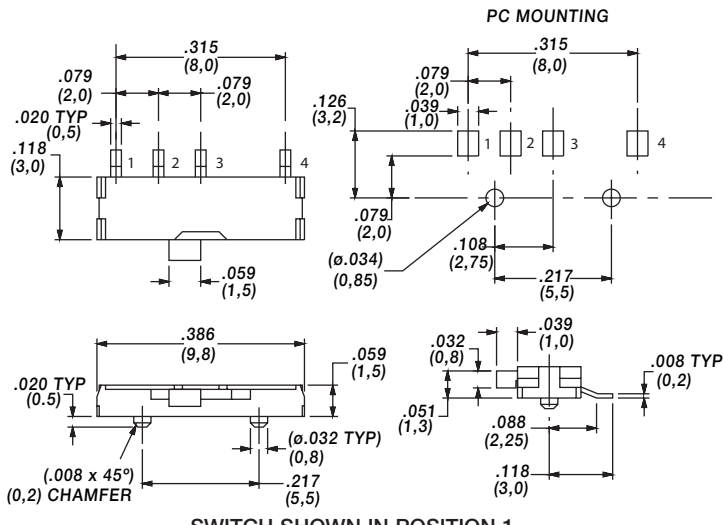

| PART NUMBER | ROHS | | SWITCH FUNCTION | | |
|---------------------|-----------|------------|-----------------|-------|-------|
| | Compliant | Compatible | POS.1 | POS.2 | POS.3 |
| AYZ0103AGRLC | YES | YES | ON | ON | ON |
| CONN. TERMINALS | | | 1-3 | 2-C | 3-4 |
| SCHEMATIC | | | | | |
| SP3T | | | | | |

SWITCH SHOWN IN POSITION 1

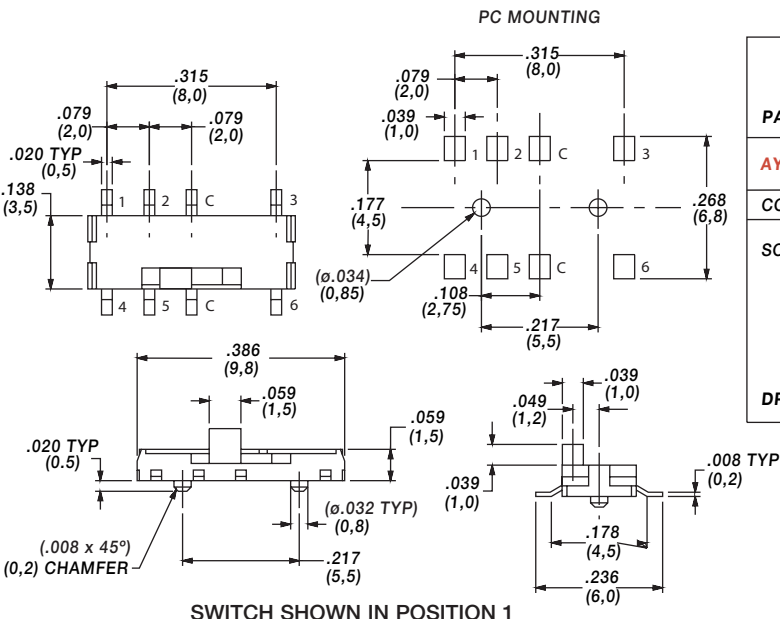

| PART NUMBER | ROHS | | SWITCH FUNCTION | | |
|---------------------|-----------|------------|-----------------|---------|---------|
| | Compliant | Compatible | POS.1 | POS.2 | POS.3 |
| AYZ0203AGRLC | YES | YES | ON | ON | ON |
| CONN. TERMINALS | | | 1-C,4-C | 2-C,5-C | 3-C,6-C |
| SCHEMATIC | | | | | |
| DP3T | | | | | |

SWITCH SHOWN IN POSITION 1



Dimensions are shown: Inches (mm)
Specifications and dimensions subject to change



AYZ Series Miniature Slide Switches

TAPE & REEL

For part number AYZ0102AGRLC

Quantity per reel 4000

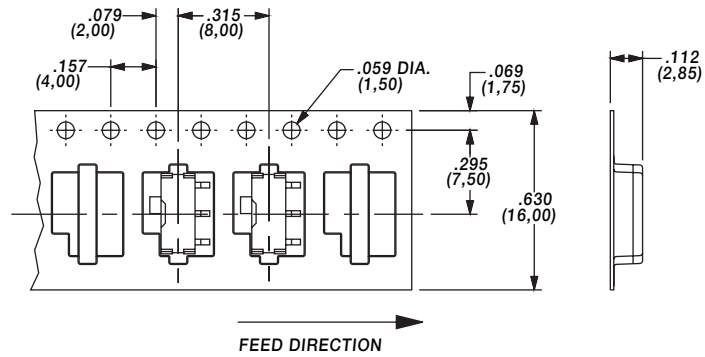

For part number AYZ0103AGRLC

Quantity per reel 4000

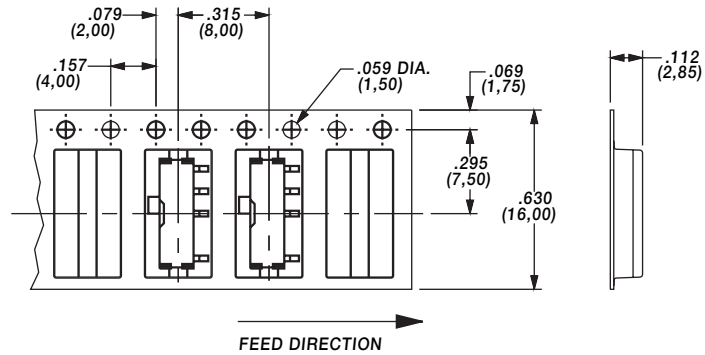

For part number AYZ0202AGRLC

Quantity per reel 3000

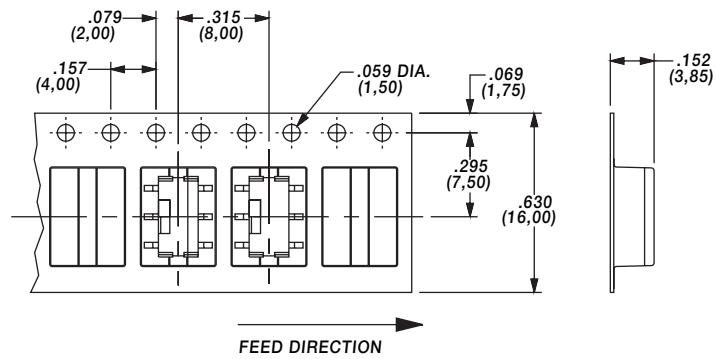

For part number AYZ0203AGRLC

Quantity per reel 3000

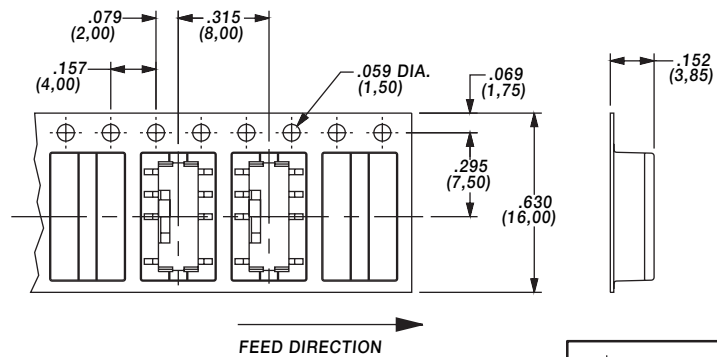

Dimensions are shown: Inch (mm)
Specifications and dimensions subject to change



Slide



—

JS Series Sub-Miniature Slide Switches

Features/Benefits

- Positive detent
- Low profile
- IR reflow to 260° solder profile
- Surface and thru hole mounting
- SPDT, DPDT, DP3T models
- RoHS compliant

Typical Applications

- Telecommunication products
- Computer peripherals
- Thermostat select switch
- Instrumentations

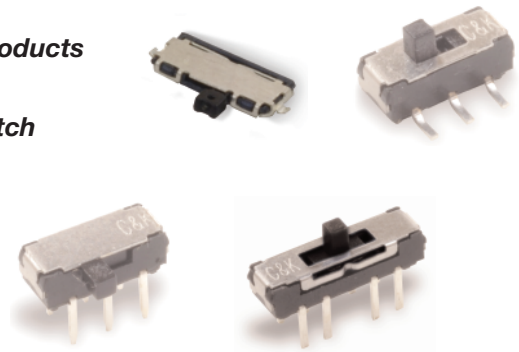

Specifications

CONTACT RATING: 6 VDC @ 0.3A
 ELECTRICAL LIFE: 5,000 make-and-break cycles
 CONTACT RESISTANCE: 70 m Ω max.
 INSULATION RESISTANCE: 100 M Ω min. @ 500V.
 DIELECTRIC STRENGTH: 500 VAC min. @ sea level.
 OPERATING TEMPERATURE: -40°C to +85°C
 STORAGE TEMPERATURE: -40°C to +85°C

NOTE: Specifications and materials listed above are for switches with standard options.
 For information on specific and custom switches, consult Customer Service Center.

Materials

HOUSING: 4/6 nylon (UL94V-2), black.
 ACTUATOR: 4/6 nylon (UL94V-2), black (some options white).
 CONTACTS: Copper alloy, silver plated.
 TERMINALS: Brass, silver plated

RIGHT ANGLE, PC THRU-HOLE

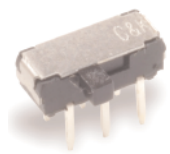
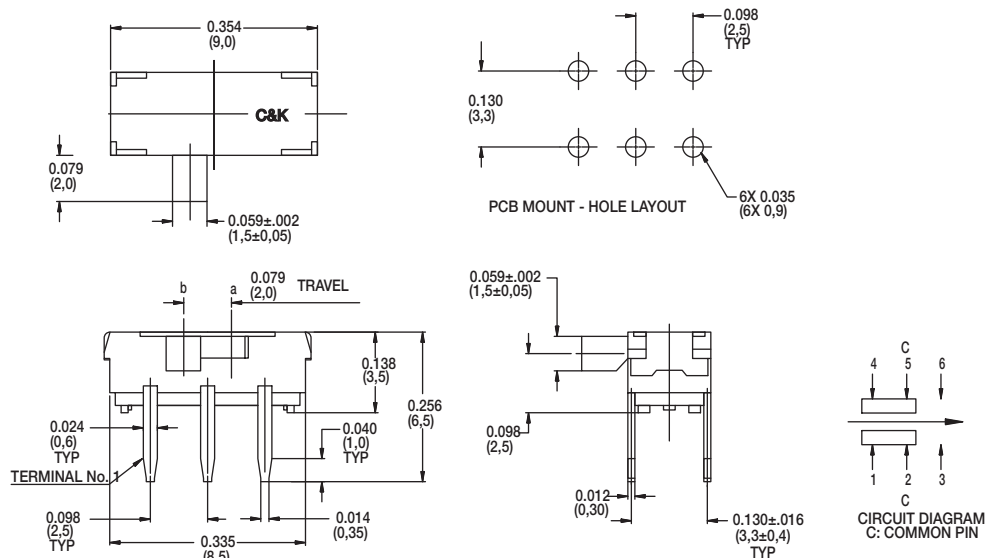

Part Number
JS202011AQN
DPDT

Shown in position b

Shown in position b

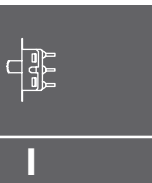

Slide

JS Series Sub-Miniature Slide Switches

RIGHT ANGLE, PC THRU-HOLE

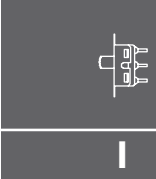

Slide

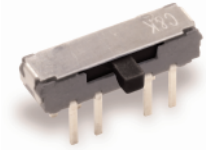
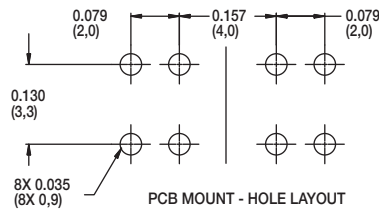
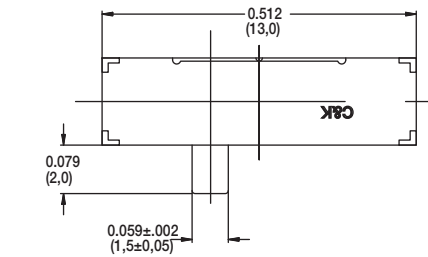

Part Number
JS203011AQN
DP3T

Shown in position b

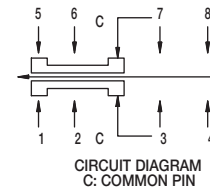
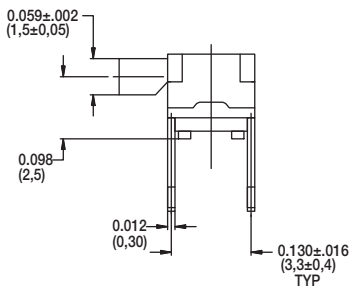
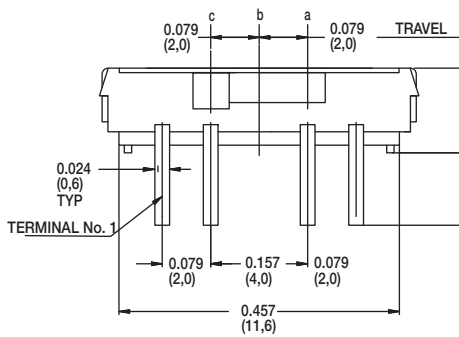

Shown in position c

PC THRU-HOLE

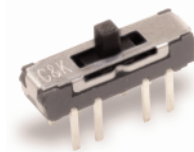
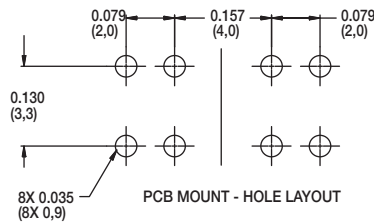
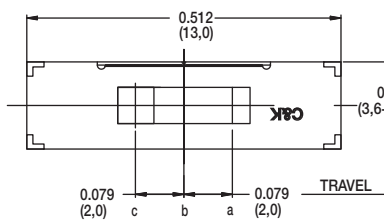

Part Number
JS203011CQN
DP3T

Shown in position b

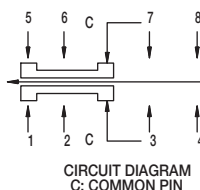
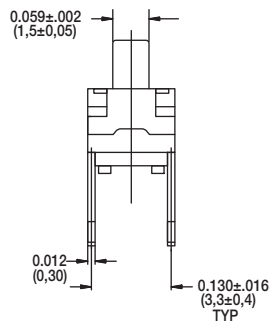
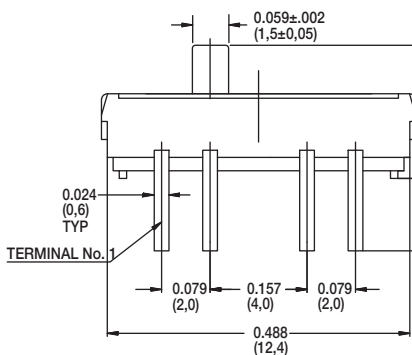

Shown in position c

JS Series Sub-Miniature Slide Switches

PC THRU-HOLE

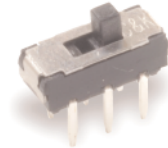
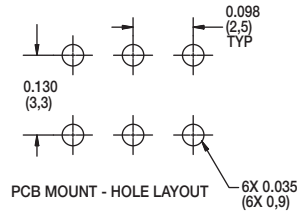
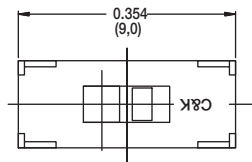

Part Number
JS202011CQN
DPDT

Shown in position a

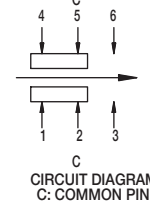
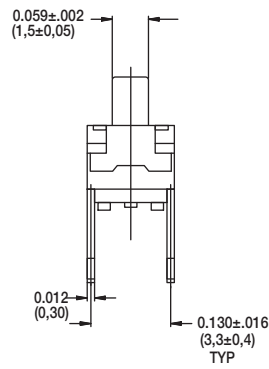
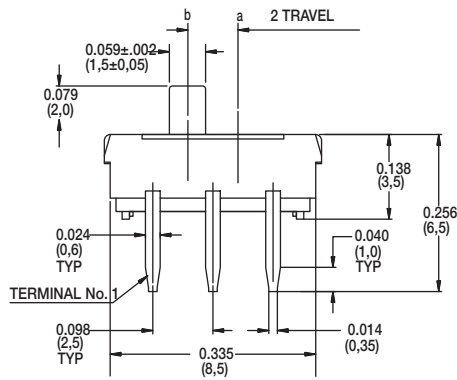

Shown in position b

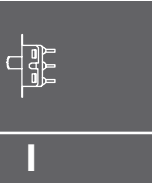

Slide

SURFACE MOUNT

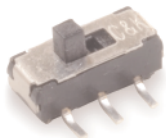

Part number
JS203011SCQN
DP3T

Shown in position b. Quantity per reel 1000
Available in tape & reel only, see page I-58

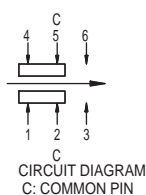
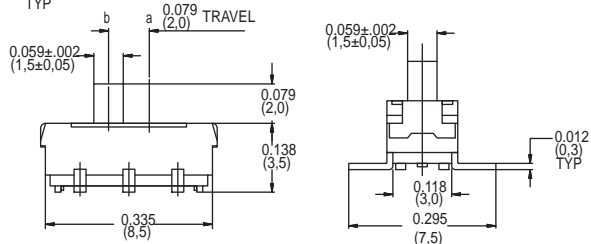
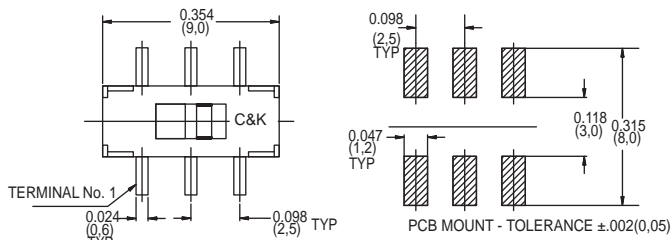

Shown in position b

Part number
JS203011SCQN
DP3T

Quantity per reel 900
Available in tape & reel only, see page I-60

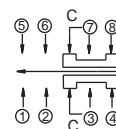
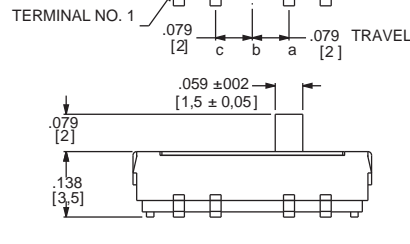
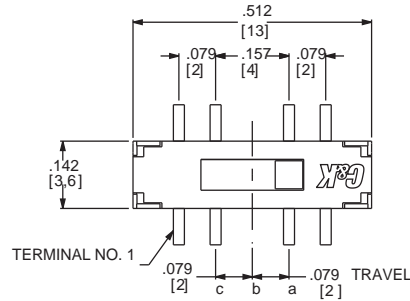

Shown in position a

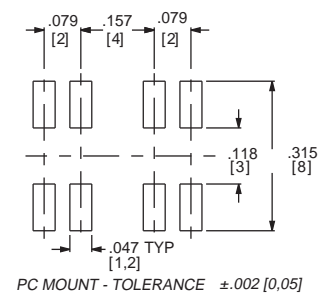

PC MOUNT - TOLERANCE ±.002 [0,05]

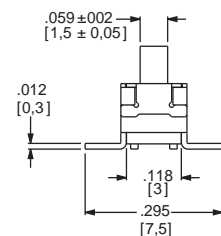

Third Angle Projection

Dimensions are shown: Inches (mm)
Specifications and dimensions subject to change

JS Series Sub-Miniature Slide Switches

RIGHT ANGLE SURFACE MOUNT

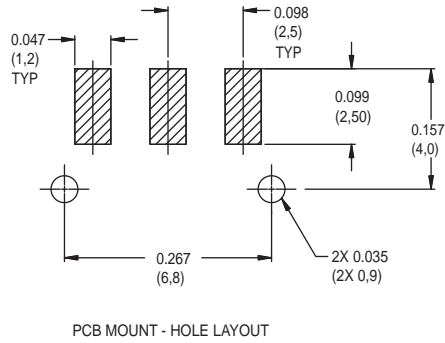
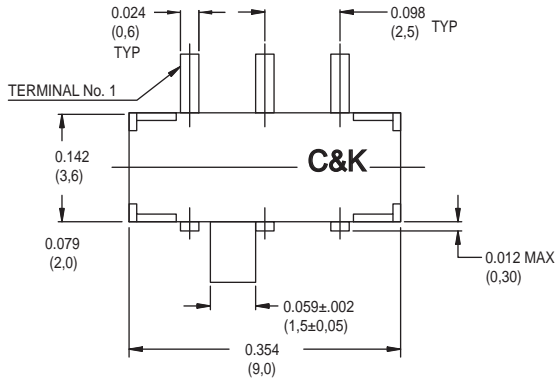

Part Number
JS102011SAQN
SPDT

Shown in position a

Available in tape & reel only, see page I-59

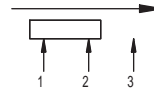
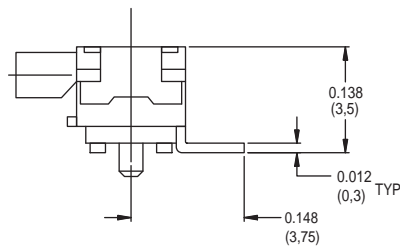
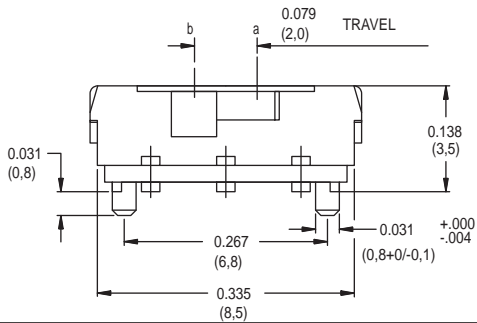

Shown in position b

Slide

PC THRU-HOLE

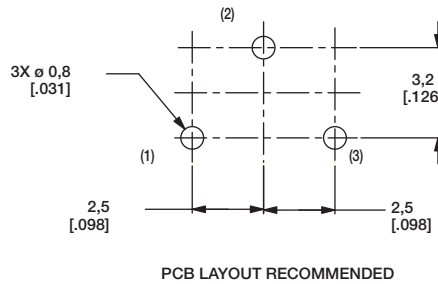
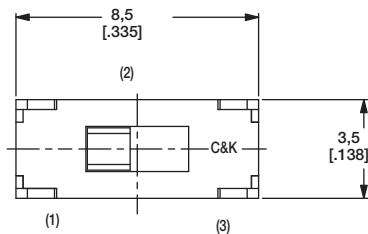

Part Number
JS102011CQN
SPDT

Shown in position a

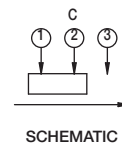
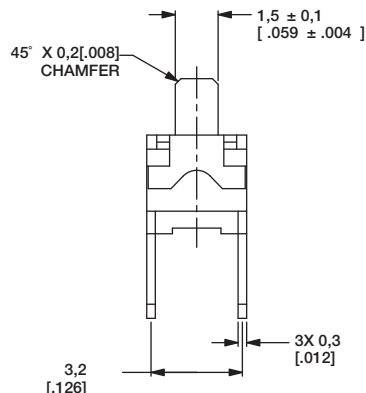
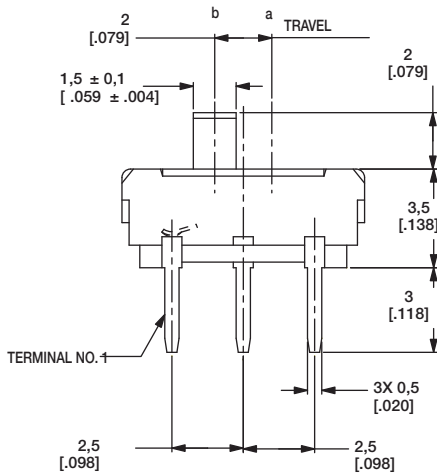

Shown in position b

JS Series Sub-Miniature Slide Switches

SURFACE MOUNT

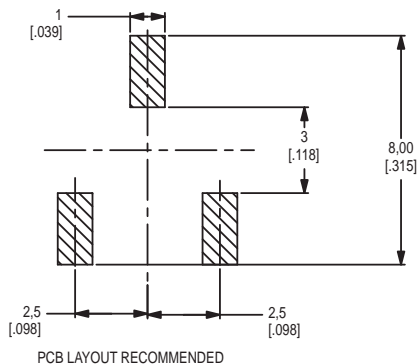
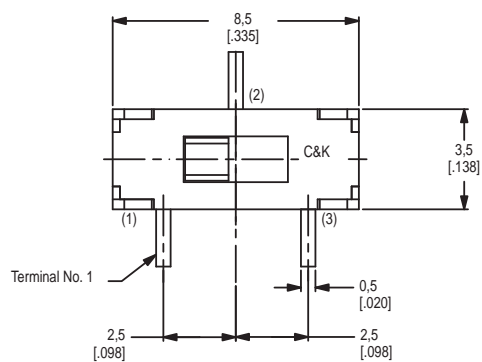

Part Number
JS102011SCQN
SPDT

Shown in position a

Available in tape & reel
only, see page I-59

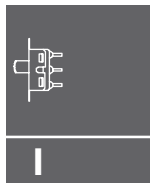

Slide

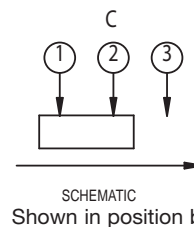
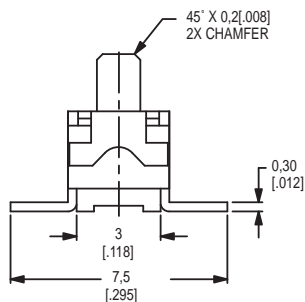
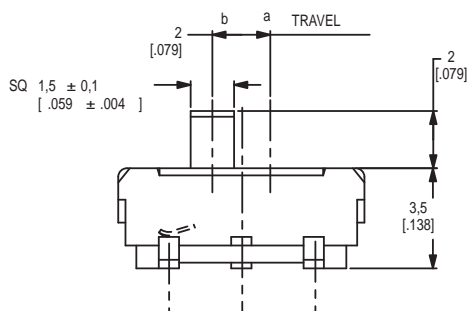

SURFACE MOUNT

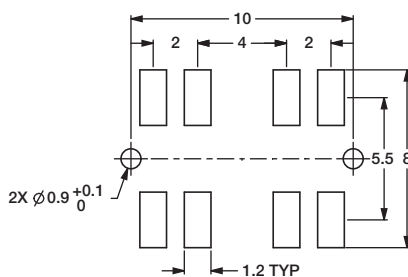
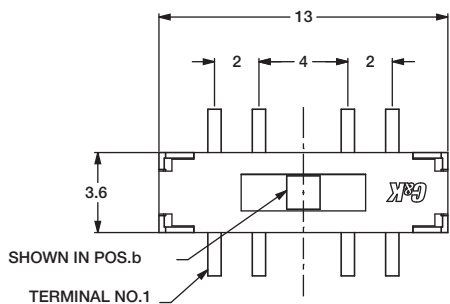

PC MOUNT - TOLERANCE ± .05

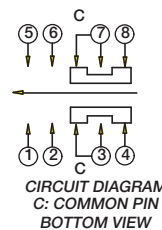

Part Number
JS207011SCQNR
DP3T

Shown in position b

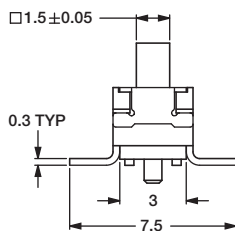
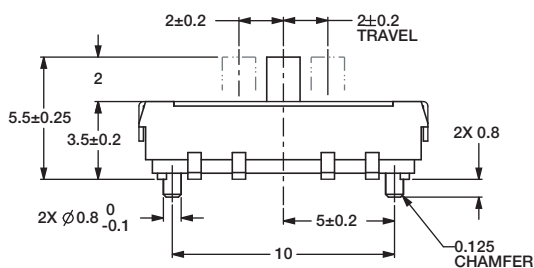

| SWITCH FUNCTION | | |
|---------------------|-----------|-----------|
| POS.c | POS.b | POS.a |
| C&K (MOM) | C&K ON | C&K ON |
| CONNECTED TERMINALS | | |
| 1-3,5-7 | 2-3,6-7 | 3-4,7-8 |

Available in tape & reel
only, see page I-58

JS Series Sub-Miniature Slide Switches

PC THRU-HOLE

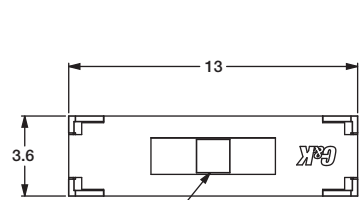

SHOWN IN POS.b

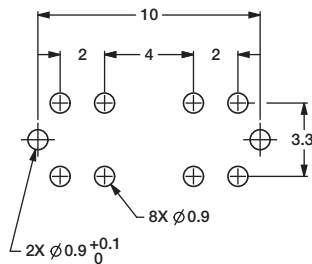

PC MOUNT - TOLERANCE $\pm .05$

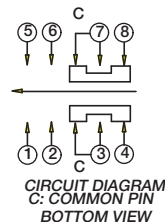

CIRCUIT DIAGRAM
C: COMMON PIN
BOTTOM VIEW

| SWITCH FUNCTION | | |
|---------------------|---------|---------|
| POS.c | POS.b | POS.a |
| | | |
| (MOM) | ON | ON |
| CONNECTED TERMINALS | | |
| 1-3,5-7 | 2-3,6-7 | 3-4,7-8 |

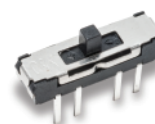

Part Number
JS207011CQNR
DP3T

Shown in position b

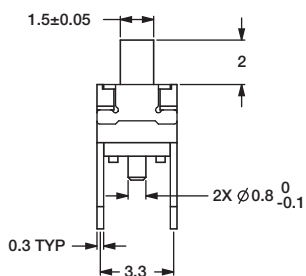
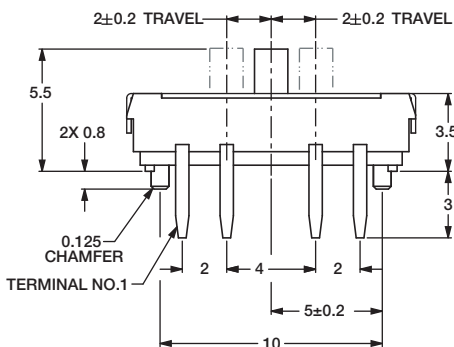

Slide

RIGHT ANGLE SURFACE MOUNT

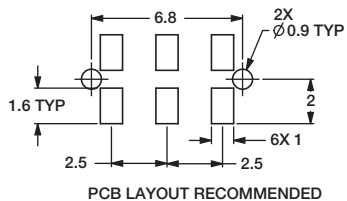
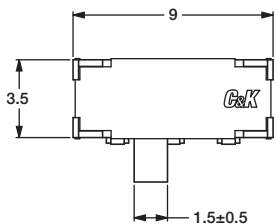

PCB LAYOUT RECOMMENDED

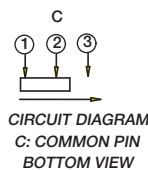

CIRCUIT DIAGRAM
C: COMMON PIN
BOTTOM VIEW



Part Number
JS102011JAQN
SPDT

Shown in position

Available in tape & reel
only, see page I-59

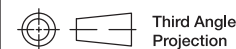
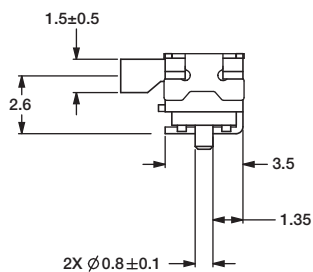
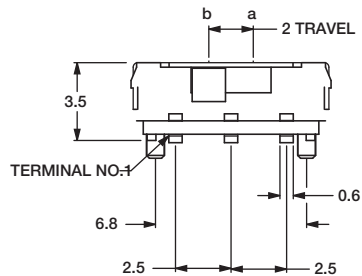

Third Angle
Projection
Dimensions are shown: mm
Specifications and dimensions subject to change



29 jun 16

JS Series Sub-Miniature Slide Switches

VERTICAL MOUNT SMT - J BEND

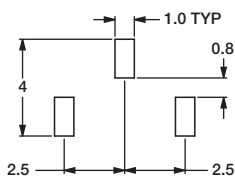
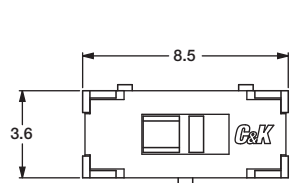

PCB LAYOUT RECOMMENDED

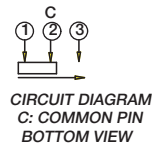

NEW
Part Number
JS102011JCQN
SPDT

Available in tape & reel
only, see page I-59

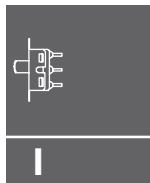

Slide

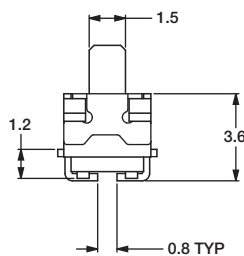
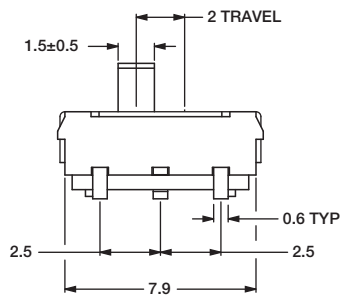

RIGHT ANGLE SURFACE MOUNT

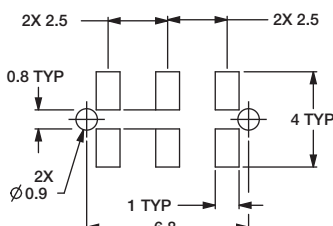
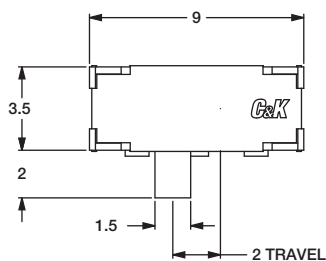

PCB LAYOUT RECOMMENDED

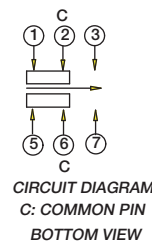

NEW
Part Number
JS202011JAQN
DPDT

Shown in position

Available in tape & reel
only, see page I-61

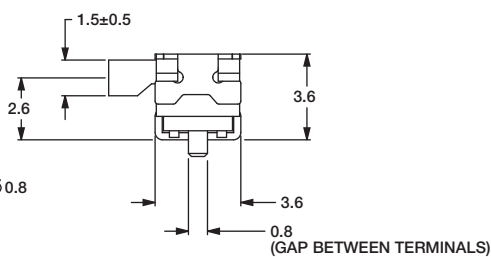
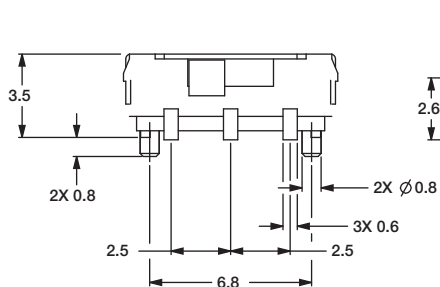

Dimensions are shown: mm
Specifications and dimensions subject to change

JS Series Sub-Miniature Slide Switches

VERTICAL MOUNT SMT - J BEND

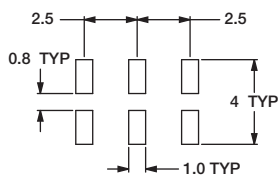
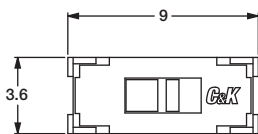

PCB LAYOUT RECOMMENDED

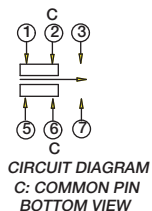

NEW

Part Number
JS202011JCQN

DPDT

Shown in position

Available in tape & reel
only, see page I-61

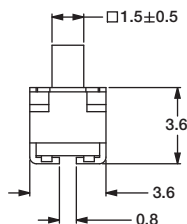
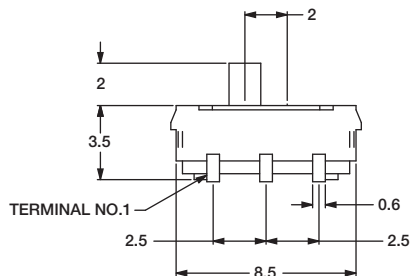

Slide

RIGHT ANGLE MOUNT SMT - J BEND

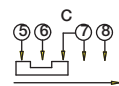
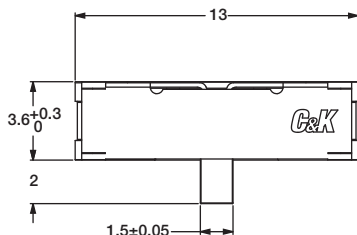

NEW

Part Number
JS203011JAQN

DP3T

Shown in position

Available in tape & reel
only, see page I-60

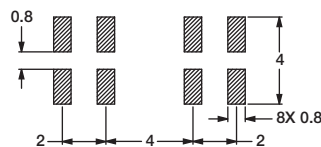
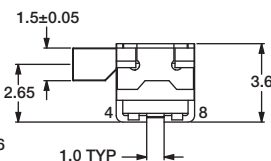
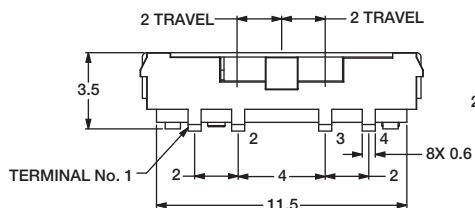

JS Series Sub-Miniature Slide Switches

VERTICAL MOUNT SMT - J BEND

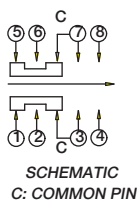
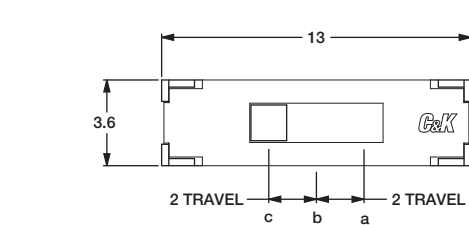

Part Number
JS203011JCQN
DP3T

Available in tape & reel
only, see page I-60

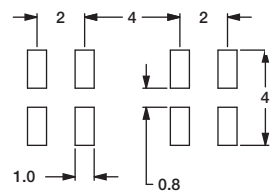
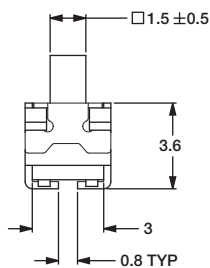
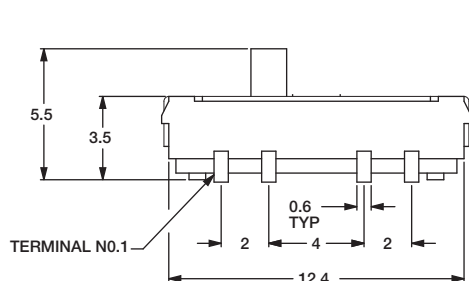

PCB LAYOUT RECOMMENDED

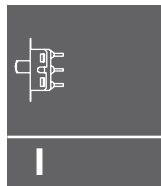

Slide

SURFACE MOUNT - J BEND

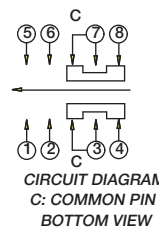
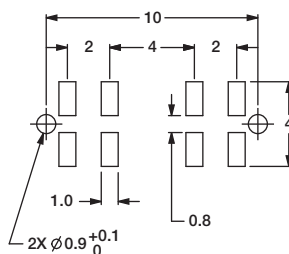
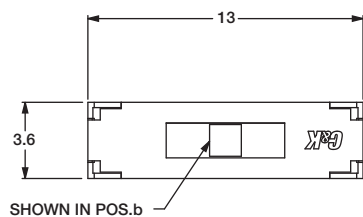

Part Number
JS207011JCQNR
SP3T

Available in tape & reel
only, see page I-58

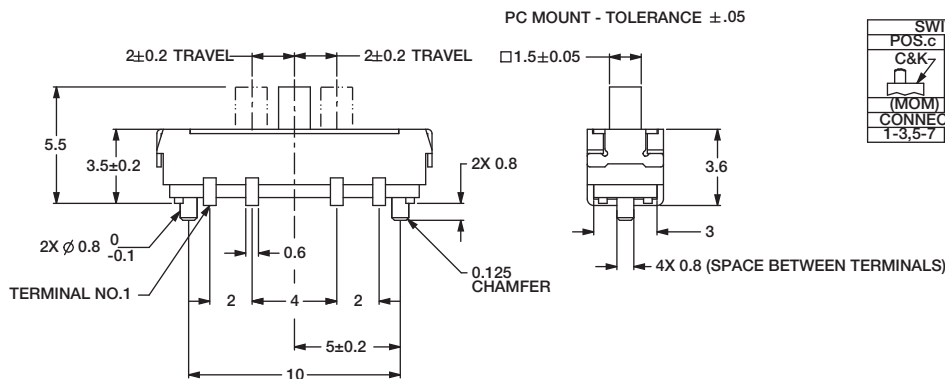

| SWITCH FUNCTION | | |
|---------------------|---------|---------|
| POS.c | POS.b | POS.a |
| C&K | C&K | C&K |
| (MOM) | ON | ON |
| CONNECTED TERMINALS | | |
| 1-3,5-7 | 2-3,6-7 | 3-4,7-8 |

JS Series Sub-Miniature Slide Switches

TAPE AND REEL FOR PART NUMBER JS207011SCQNR, JS207011JCQNR

Quantity per reel 800

PACKING DETAIL 800 PCS

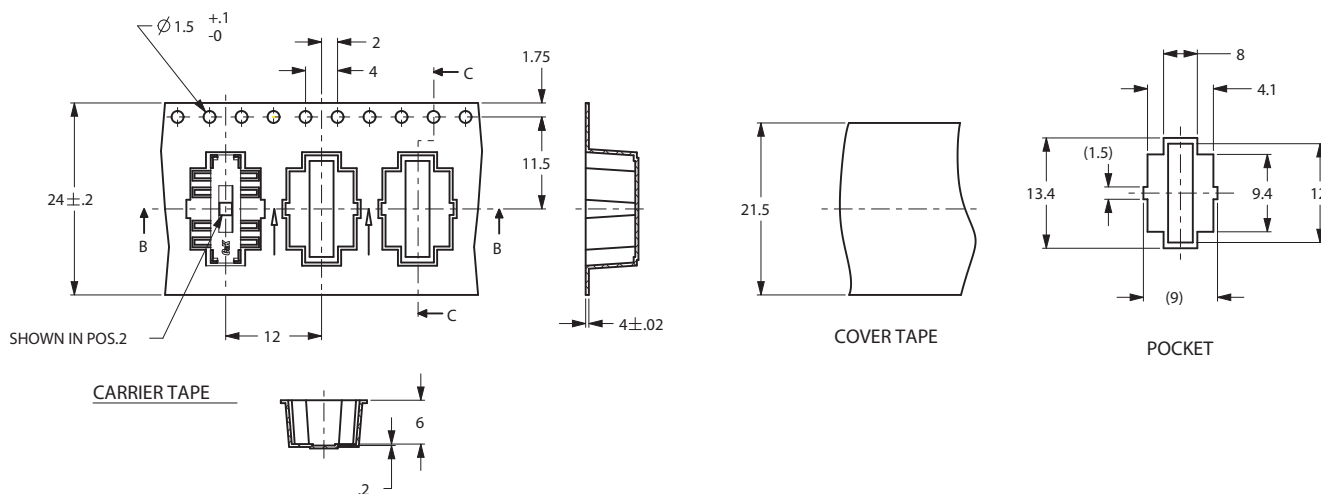
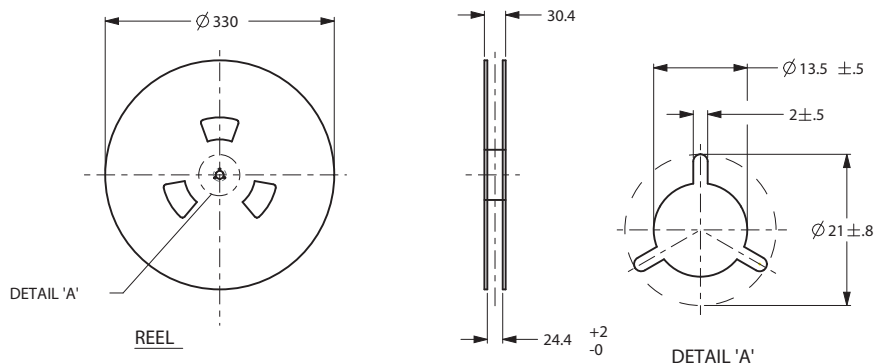

TAPE AND REEL FOR PART NUMBER JS202011SCQN

Quantity per reel 1000

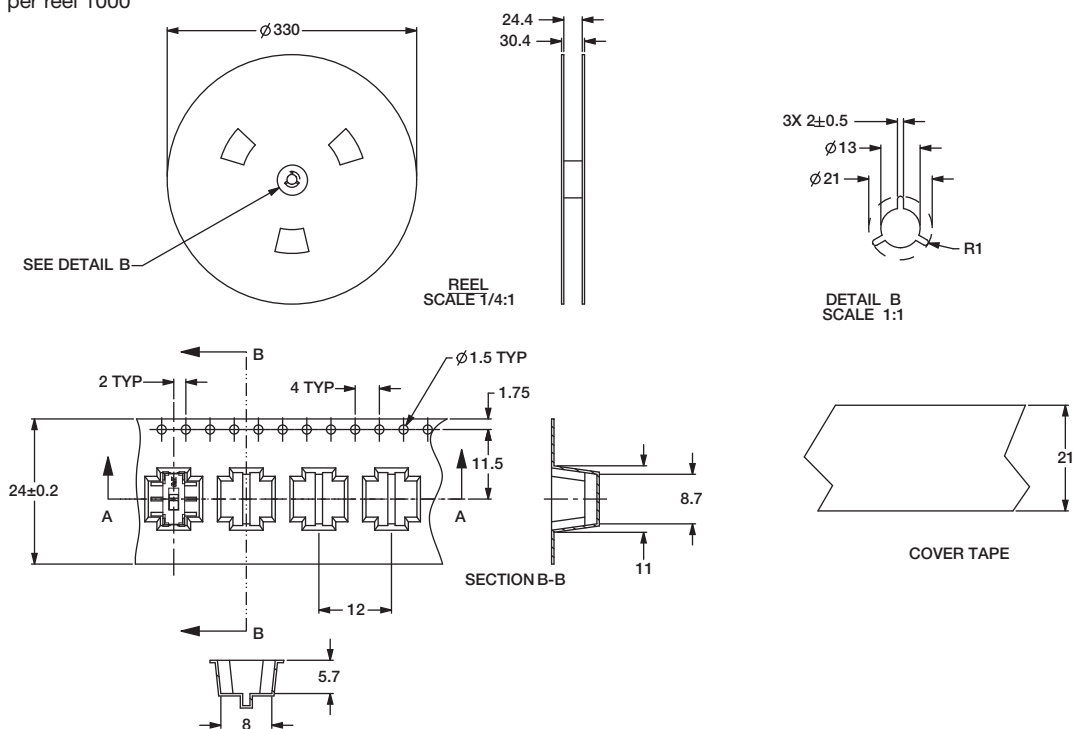

JS Series Sub-Miniature Slide Switches

TAPE AND REEL FOR
PART NUMBER JS102011SCQN, JS102011JCQN
 Quantity per reel 1000

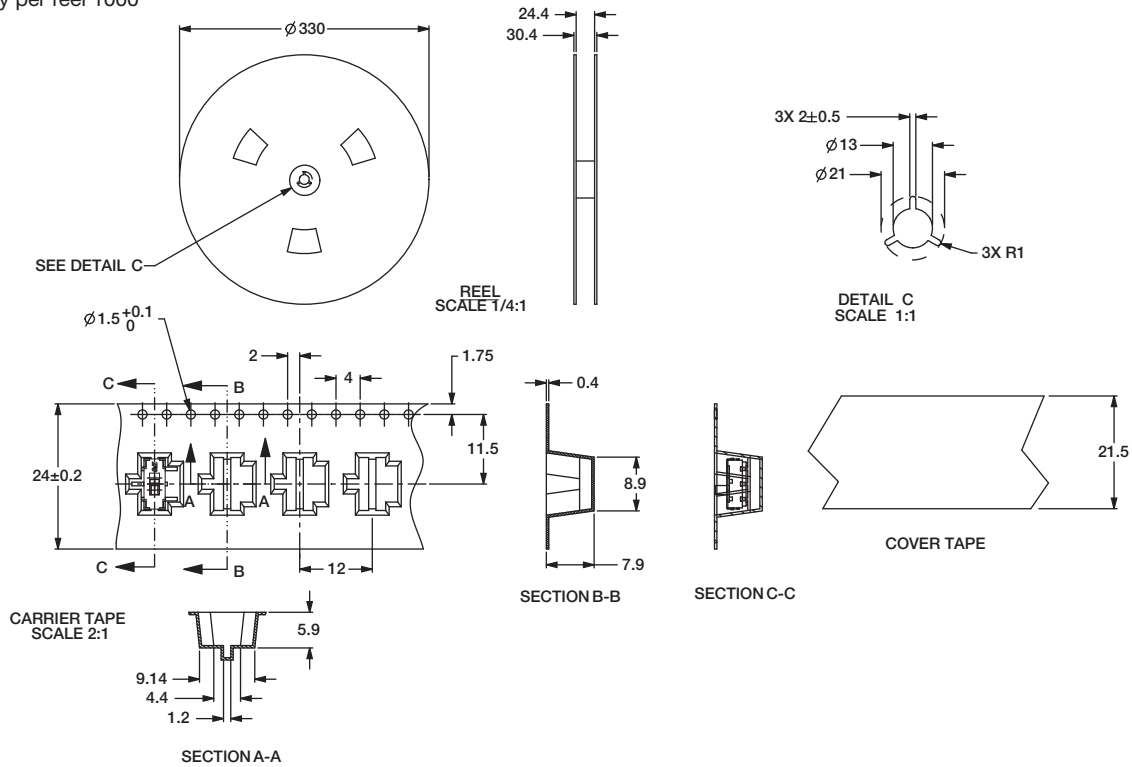

TAPE AND REEL FOR PART NUMBER JS102011SAQN, JS102011JAQN

Quantity per reel 1000

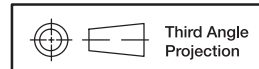
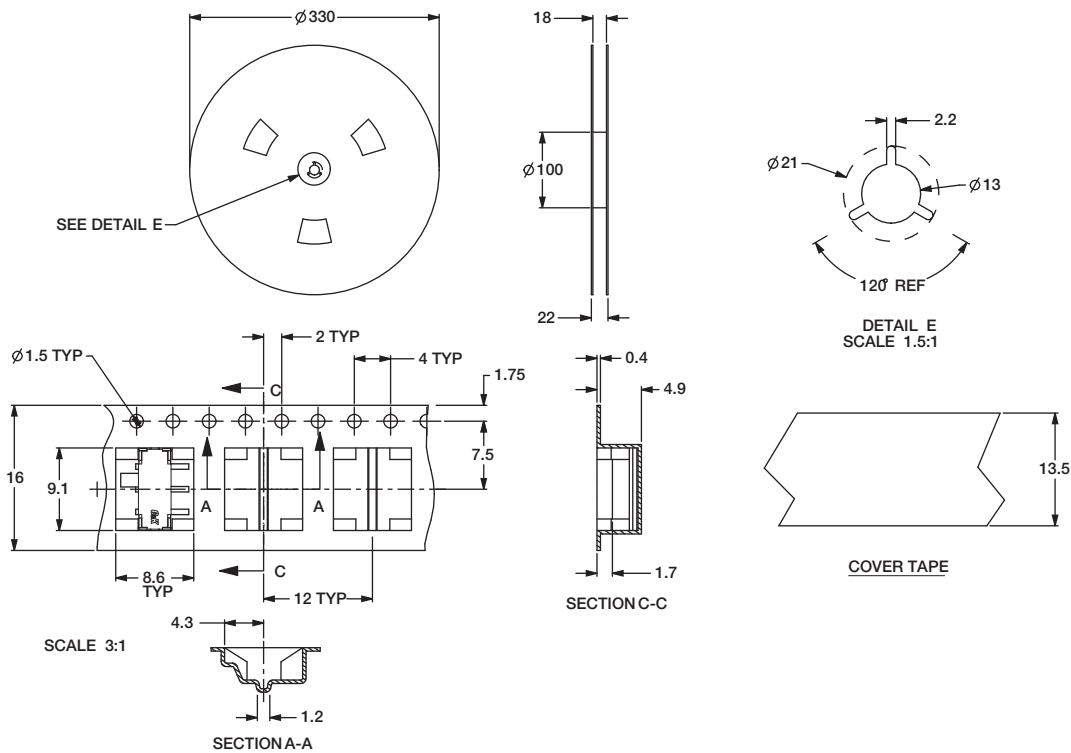

Dimensions are shown: mm
 Specifications and dimensions subject to change

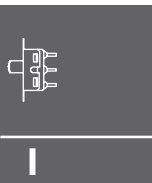

Slide

JS Series Sub-Miniature Slide Switches

TAPE AND REEL FOR PART NUMBER JS203011SCQN, JS203011JCQN
Quantity per reel 900

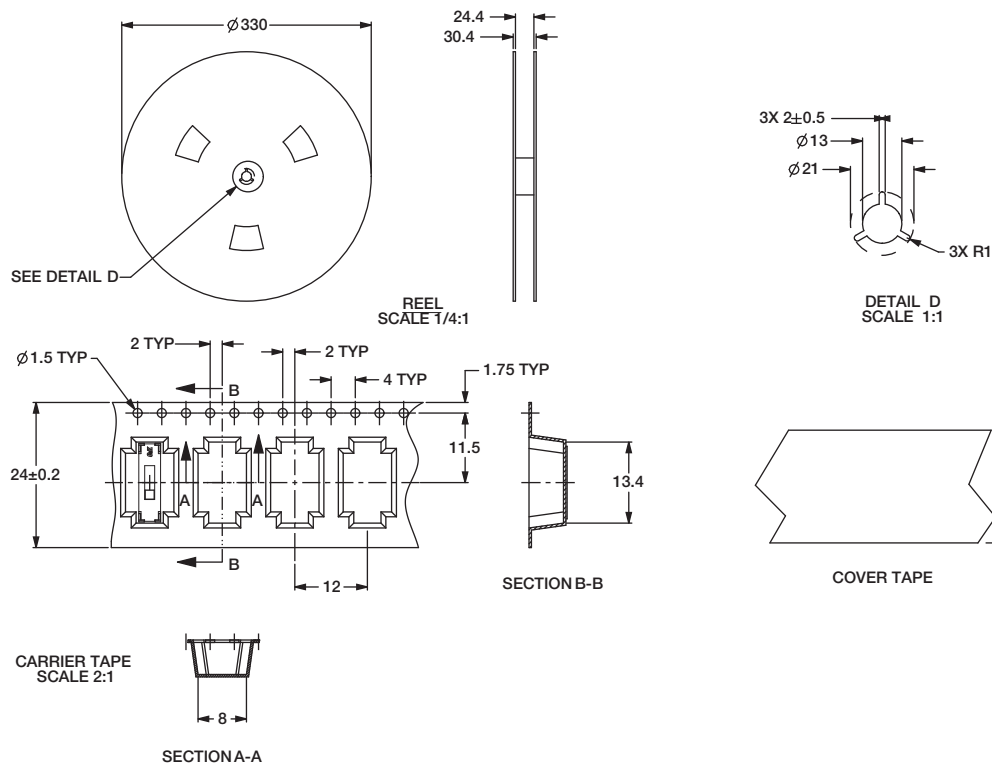

TAPE AND REEL FOR PART NUMBER JS203011JAQN

Quantity per reel 1000

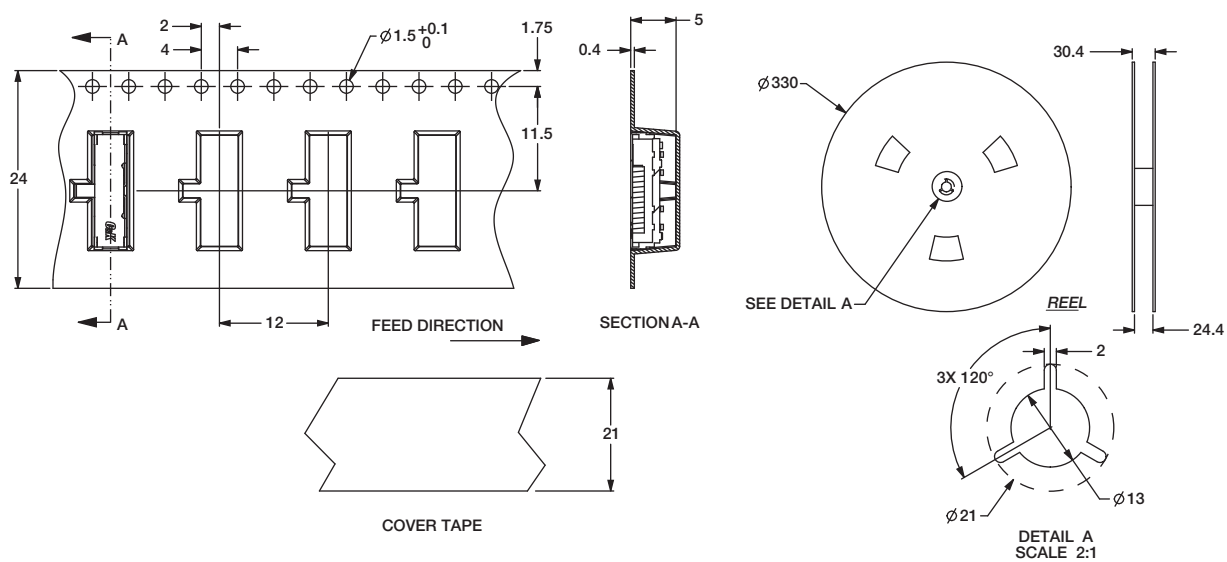

Dimensions are shown: mm
Specifications and dimensions subject to change

JS Series Sub-Miniature Slide Switches

TAPE AND REEL FOR
PART NUMBER JS202011JCQN
Quantity per reel 1300

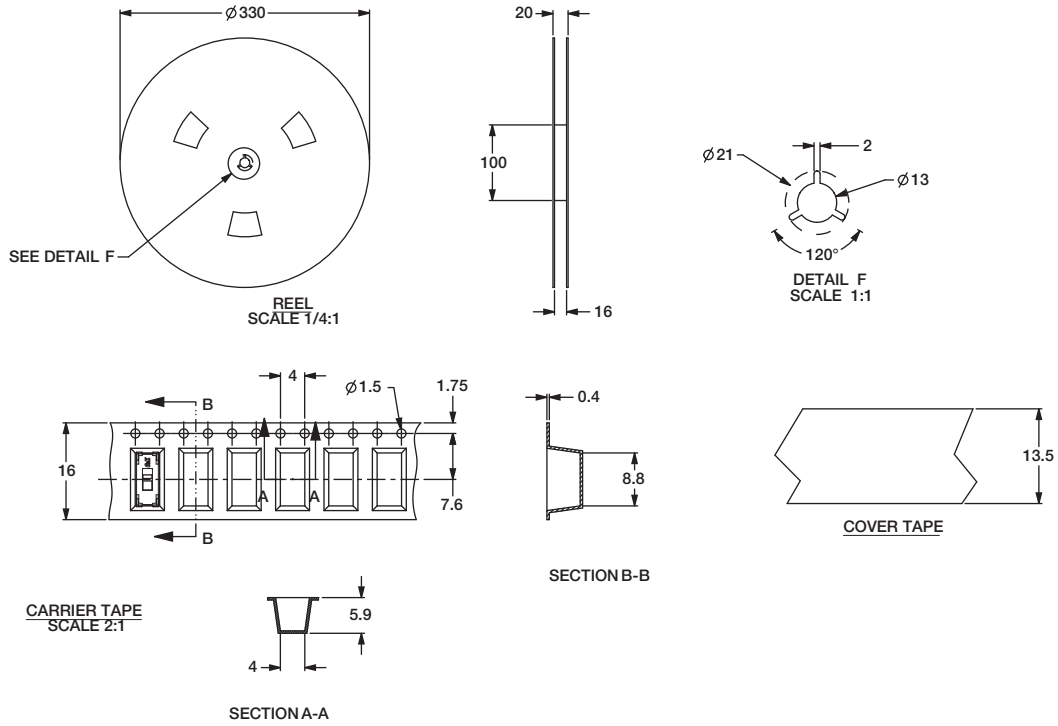

TAPE AND REEL FOR PART NUMBER JS202011JAQN
Quantity per reel 1000

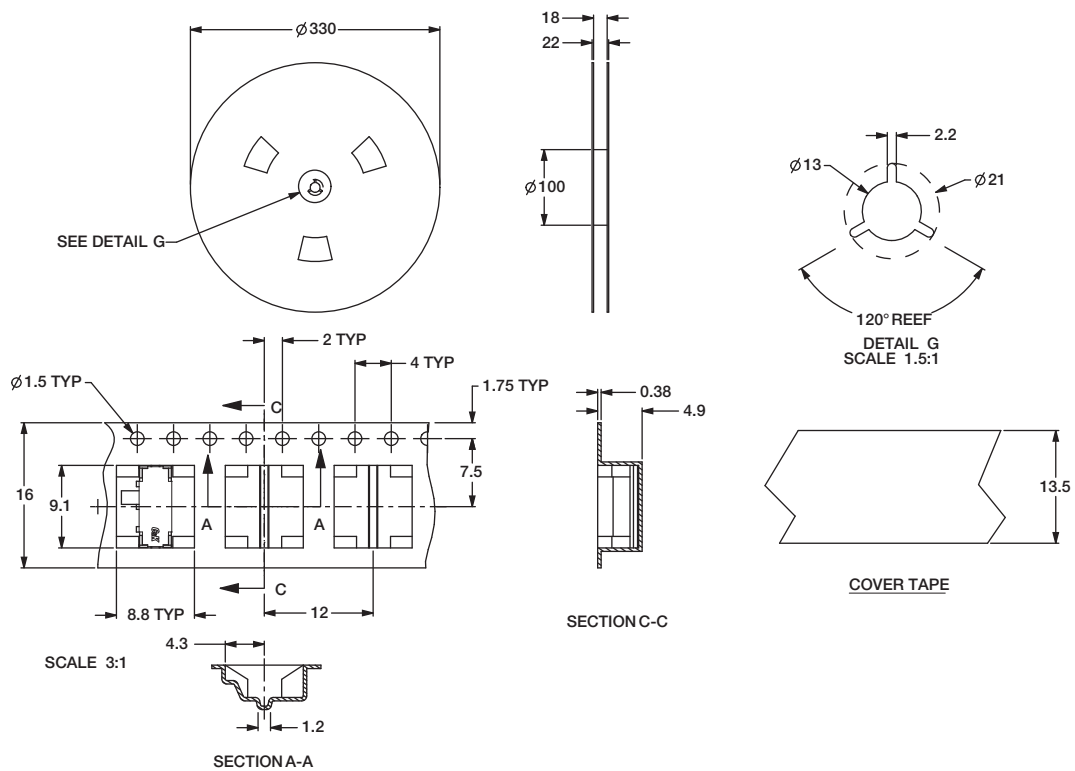

Dimensions are shown: mm
Specifications and dimensions subject to change

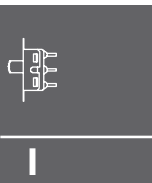

Slide

JS Series Sub-Miniature Slide Switches

RIGHT ANGLE SURFACE MOUNT

LOW PROFILE .028±.004 (0.7±0.1) HIGH



Part Number
JS102000SAQN
SPDT

Specifications

CONTACT RATING: 5 VDC @ 1MA

ELECTRICAL LIFE: 15,000 cycles.

CONTACT RESISTANCE: <100 m ohms (initial) <200 m ohms (after processing).

INSULATION RESISTANCE: 100 m ohms @500 VDC.

DIELECTRIC STRENGTH: 250 VAC.

OPERATING TEMPERATURE: -40°C to +85°C



Slide

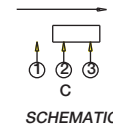
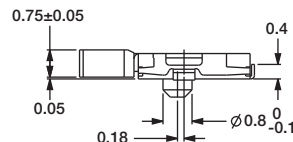
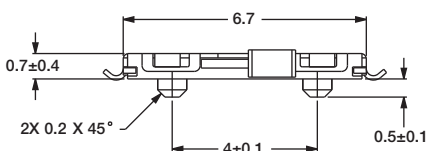
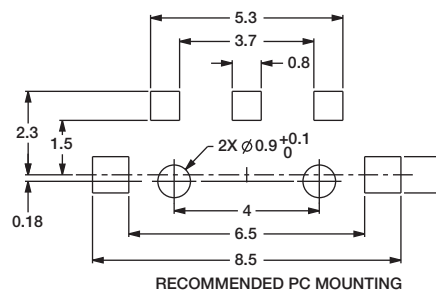
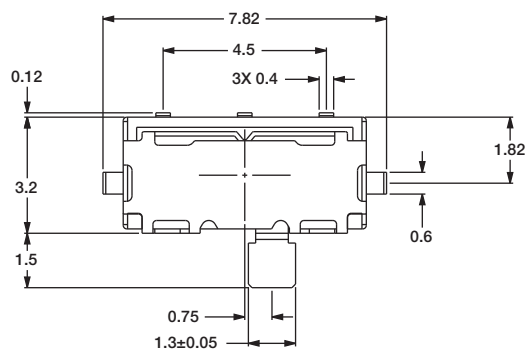

TAPE AND REEL FOR PART NUMBER JS102000SAQN

Quantity per reel 4000

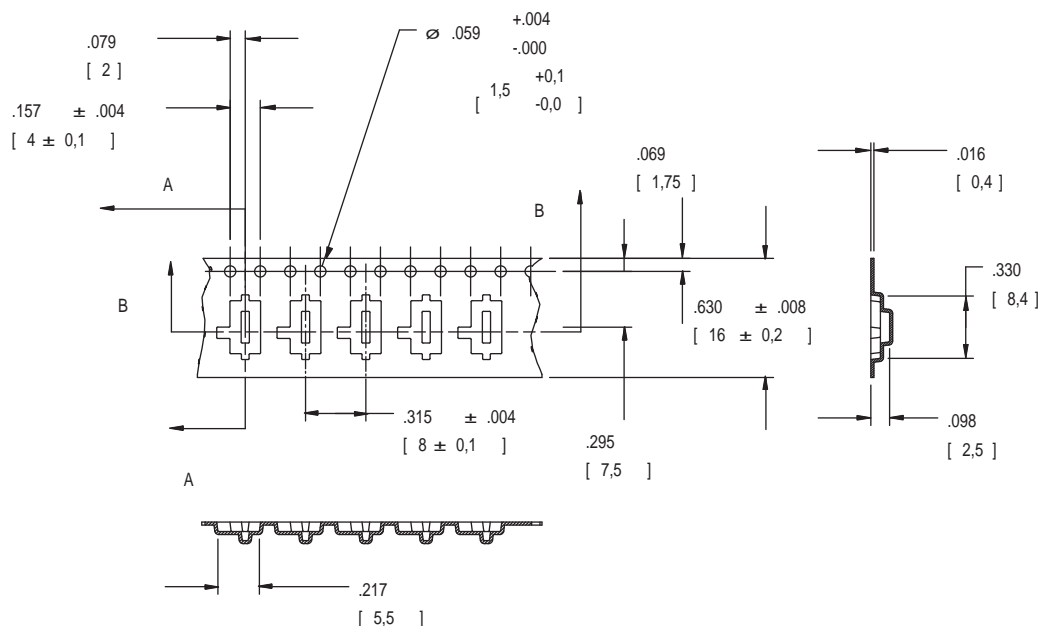

JSM Series Sub-Miniature Slide Switches

Features/Benefits

- RoHS compliant and meets all requirements of RoHS directive 2002/95EC, Halogen Free
- Positive detent
- Low profile
- IR reflow to 260° solder profile
- Surface and thru hole mounting
- Maintained and momentary functions
- SPDT, SP3T models

Typical Applications

- Telecommunication products
- Computer peripherals
- Thermostat select switch
- Instrumentations

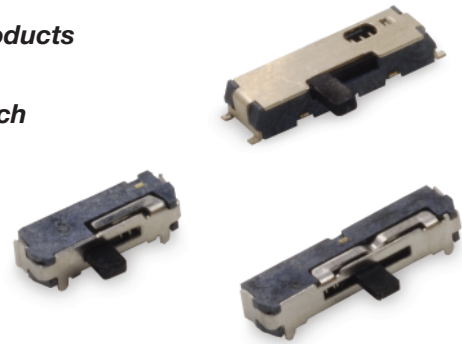

Specifications

CONTACT RATING: 4 VDC @ 0.3A
 ELECTRICAL LIFE: 10,000 make-and-break cycles at full load.
 CONTACT RESISTANCE: 70 m Ω max.
 INSULATION RESISTANCE: 100 M Ω min. @ 500V.
 DIELECTRIC STRENGTH: 100 VAC min. @ sea level.
 OPERATING TEMPERATURE: -10°C to +60°C
 STORAGE TEMPERATURE: -30°C to +85°C

NOTE: Specifications and materials listed above are for switches with standard options. For information on specific and custom switches, consult Customer Service Center.

Materials

HOUSING: LCP, Glass filled (Halogen free)
 ACTUATOR: 4/6 nylon (UL94V-2), black.
 CONTACTS: Beryllium copper, silver plated.
 TERMINALS: Brass, silver plated.
 COVER: Stainless steel
 RETURN SPRING: Stainless steel

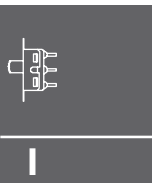

Side

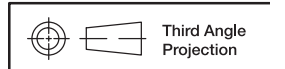
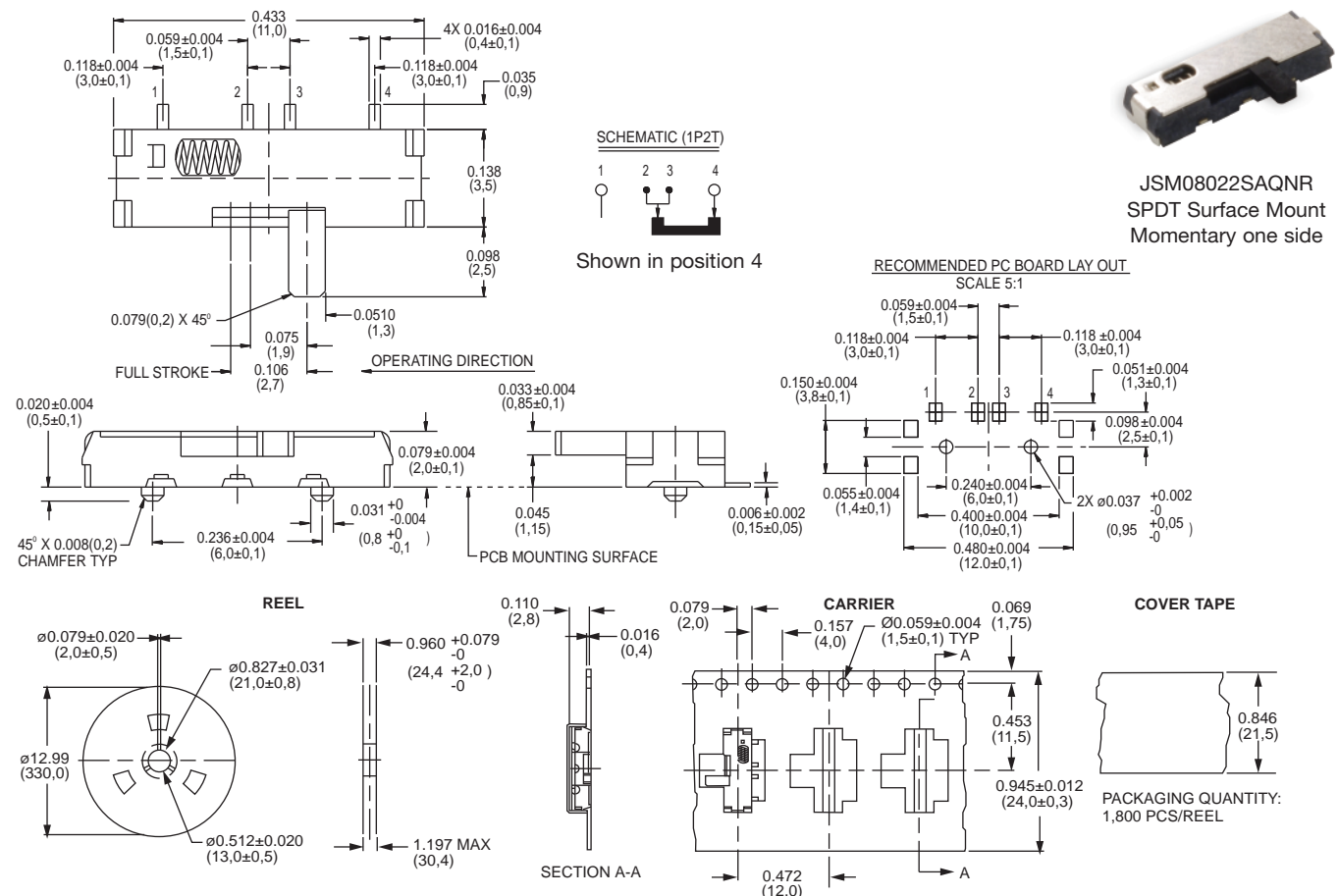

Dimensions are shown: Inches (mm)
 Specifications and dimensions subject to change

www.ck-components.com

JSM Series Sub-Miniature Slide Switches

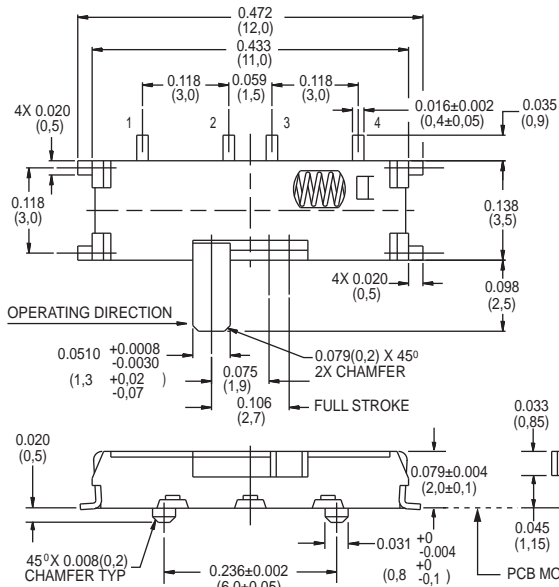

SCHEMATIC (1P2T)

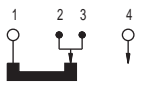

Shown in position 1

RECOMMENDED PC BOARD LAY OUT

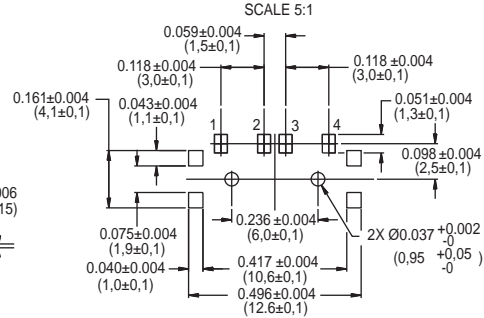

JSM08022SAQNL
SPDT Surface Mount
Momentary only

Slide

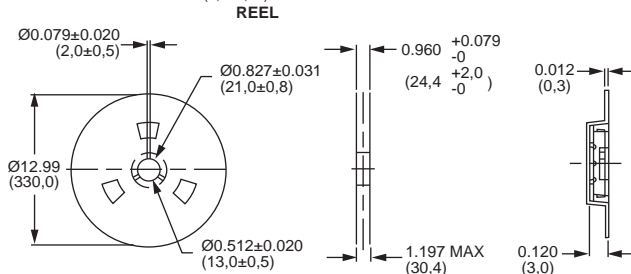

COVER TAPE

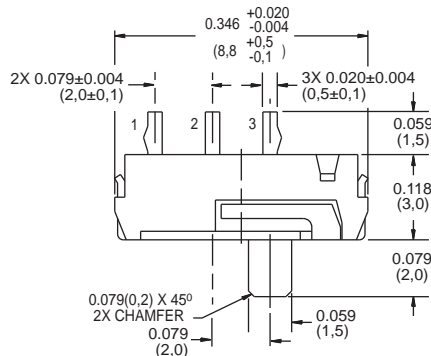
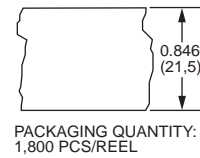

SCHEMATIC (1P2T)

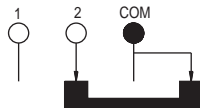

Shown in position 2

RECOMMENDED PC BOARD LAY OUT

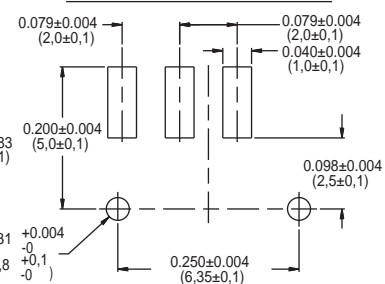

JSM08011SAQNR
SPDT Surface Mount
Momentary only

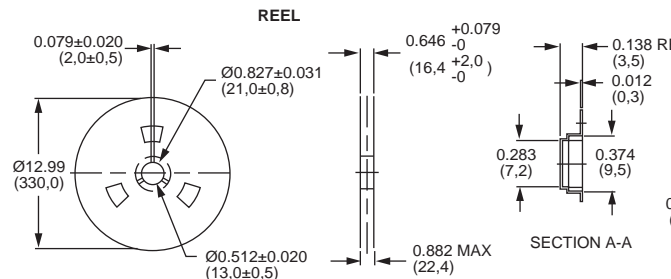

CARRIER TAPE

COVER TAPE

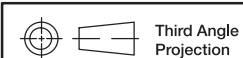
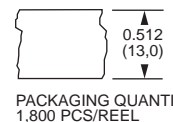

Third Angle Projection

Dimensions are shown: Inch (mm)
Specifications and dimensions subject to change



JSM Series Sub-Miniature Slide Switches

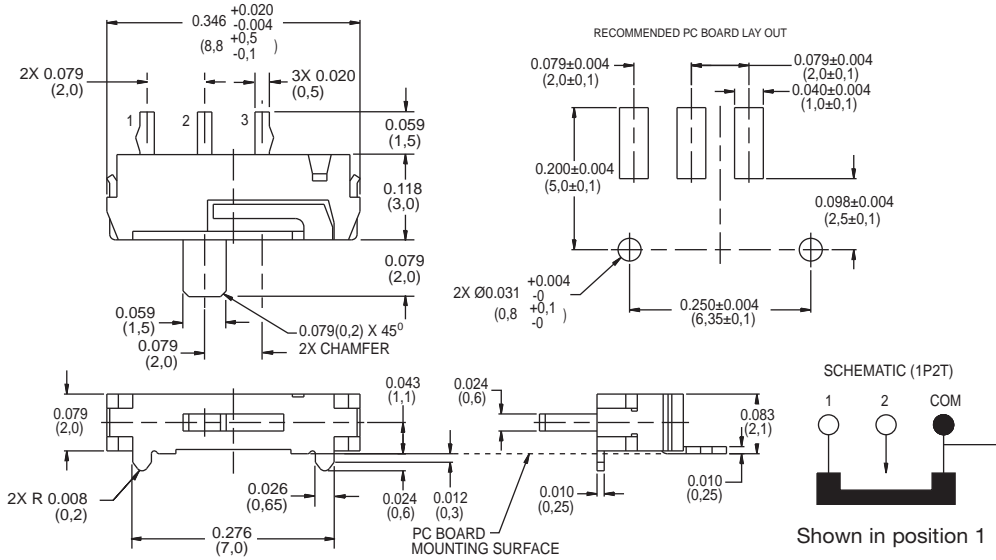

JSM08011SAQNL
SPDT Surface Mount
Momentary only

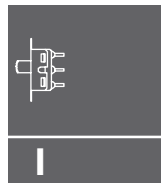

Slide

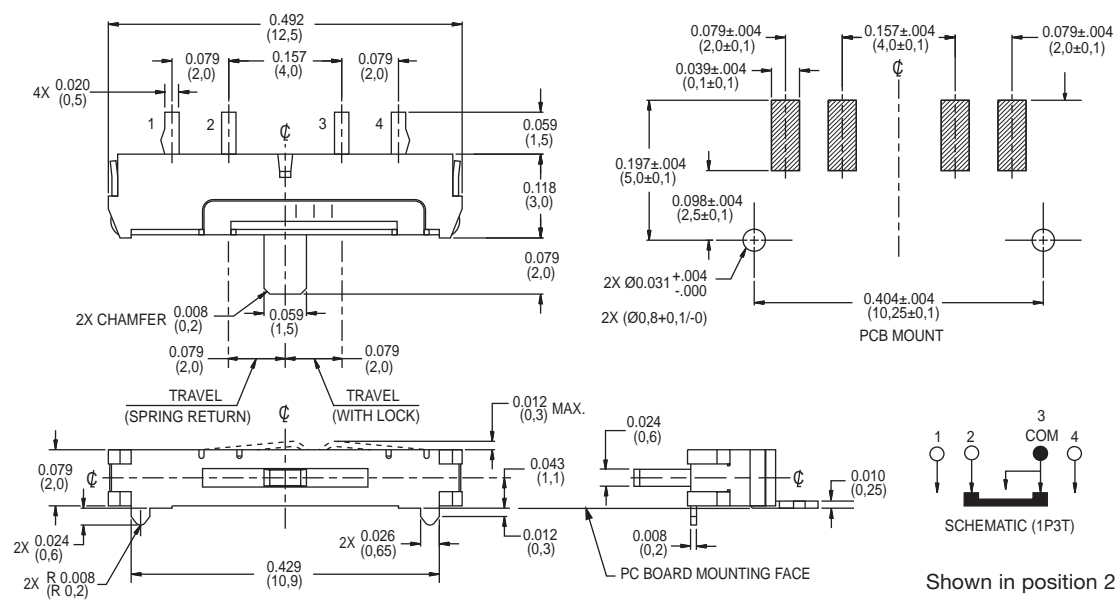
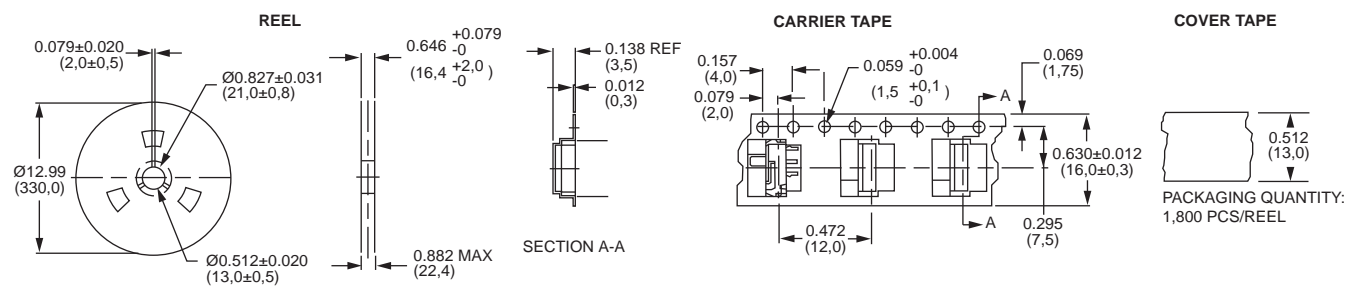

JSM07011SAQNR
SP3T Surface Mount
Momentary one side
& Maintained the other



Dimensions are shown: Inches (mm)
Specifications and dimensions subject to change

JSM Series Sub-Miniature Slide Switches

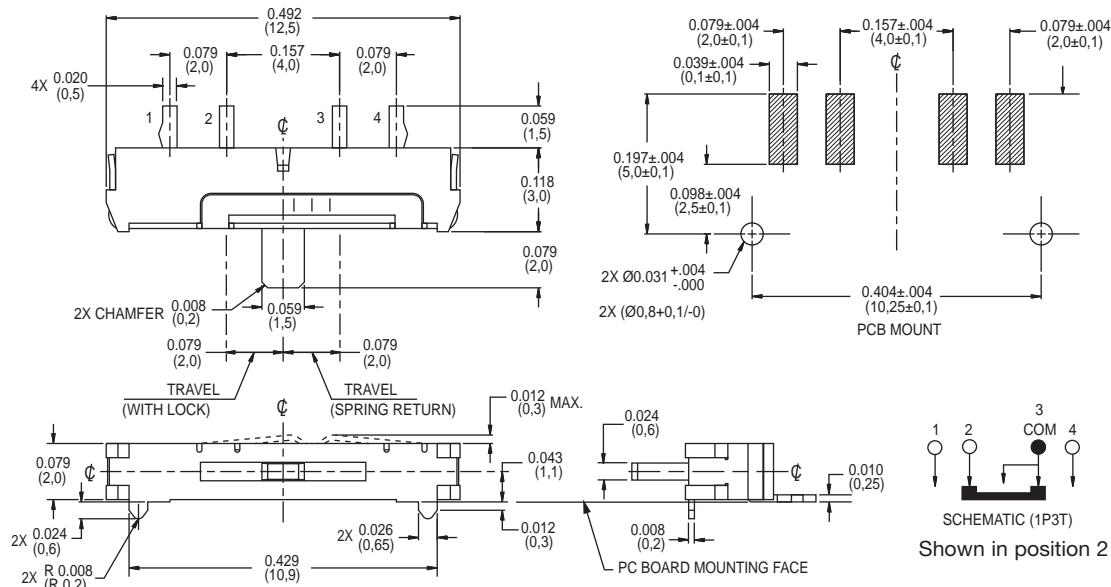

JSM07011SAQNL
SP3T Surface Mount
Momentary one side
& Maintained the other

Packaging for JSM07011SAQNR and JSM07011SAQNL

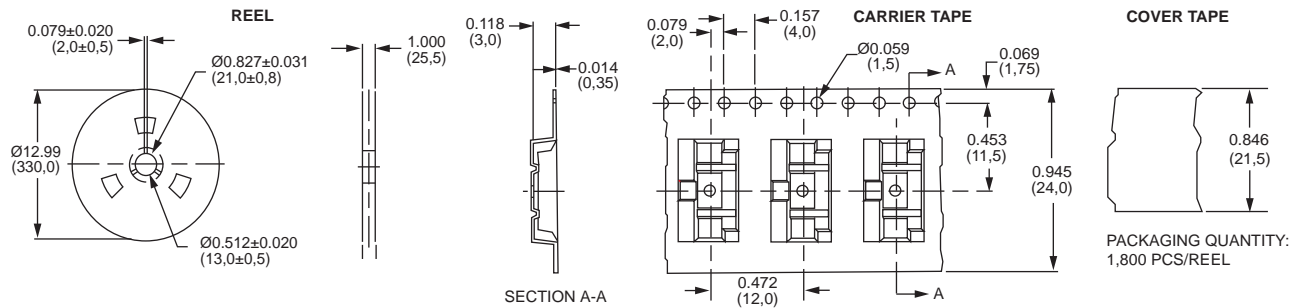

Dimensions are shown: Inch (mm)
Specifications and dimensions subject to change

JSM Series Sub-Miniature Slide Switches

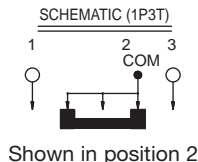
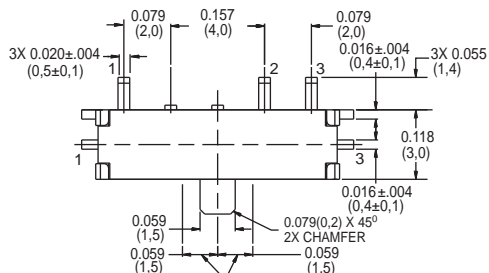

JSM05000SAQN
SP3T Surface Mount
Momentary both
sides

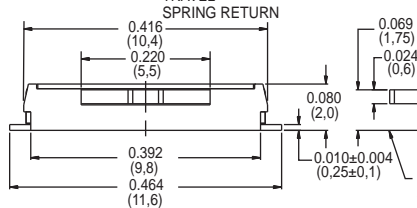

RECOMMENDED PC BOARD LAY OUT
SCALE 5:1

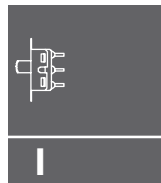
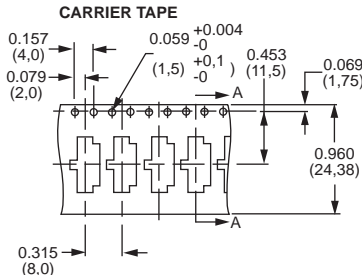
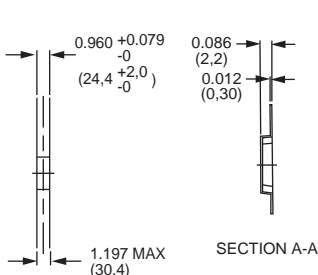
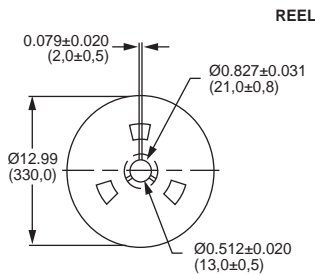
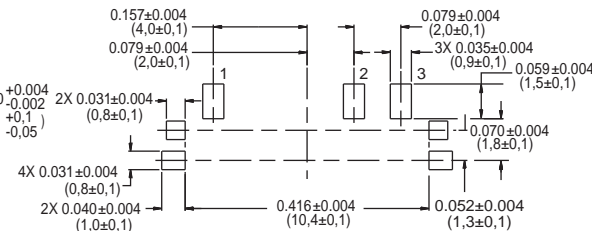

Side

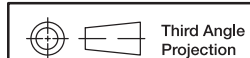

Dimensions are shown: Inches (mm)
Specifications and dimensions subject to change

JSX Series Sub-Miniature Slide Switch



Features/Benefits

- **RoHS compliant and meets all requirements of RoHS directive 2002/95EC**
- **Low profile**
- **SPDT momentary action**
- **Long electrical and mechanical life**

Typical Applications

- **On/Off touch screens**
- **Handheld games**
- **Remote controls**
- **Instrumentation**



Slide

Specifications

CONTACT RATING: 10 mA @ 5VDC (resistive).
 ELECTRICAL LIFE: 100,000 cycles.
 CONTACT RESISTANCE: 70 m Ω max. initial.
 200 m Ω max. after life testing.
 INSULATION RESISTANCE: 100 M Ω min. @ 100VDC.
 DIELECTRIC STRENGTH: 100 VAC for 1 min. @ 50/60 Hz/2mA.
 OPERATING TEMPERATURE: -25°C to +70°C
 STORAGE TEMPERATURE: -40°C to +85°C
 -25°C to +55°C (in tape & reel packaging)

Materials

HOUSING: LCP, Glass filled.
 ACTUATOR: 4/6 nylon (UL94V-2), black.
 CONTACTS: Beryllium copper, silver plated.
 TERMINALS: Phosphur bronze or StSt, silver plated.
 COVER: Nickel silver or Stainless steel, silver plated.
 RETURN SPRING: Stainless steel.

NOTE: Specifications and materials listed above are for switches with standard options. For information on specific and custom switches, consult Customer Service Center.

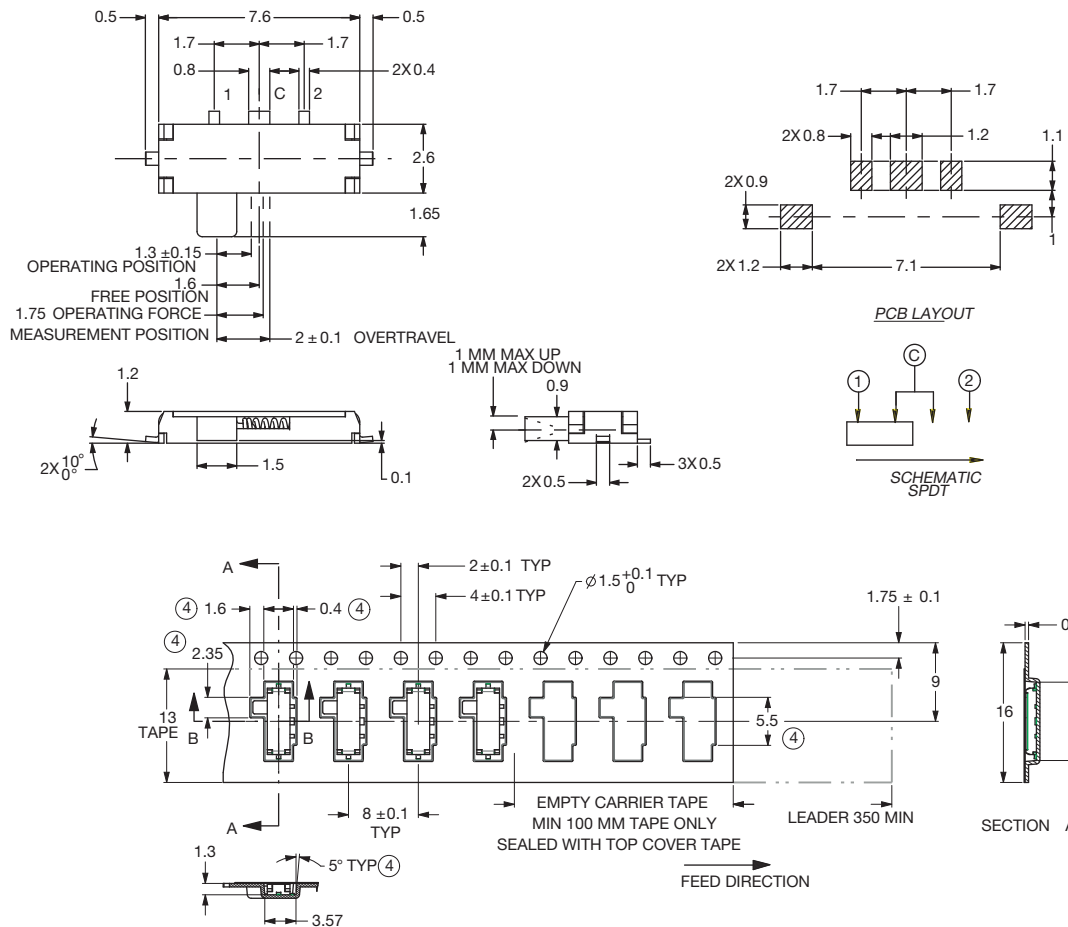

JSX08001SAQNL
SPDT Surface Mount
Momentary only

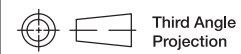

Dimensions are shown: mm
 Specifications and dimensions subject to change

SK Series Miniature Slide Switches

Features/Benefits

- Broad range of products
- Various circuit design, SPDT, 4P3T, vertical, right angle
- Compact miniature slide switch
- Shorting or non-shorting
- Custom design available

Typical Applications

- Consumer electronics
- Computer peripherals
- Telecommunication
- Audio & visual equipment
- Medical
- Automotive



SK-13D21-G 2RT 1P3T NON-SHORTING

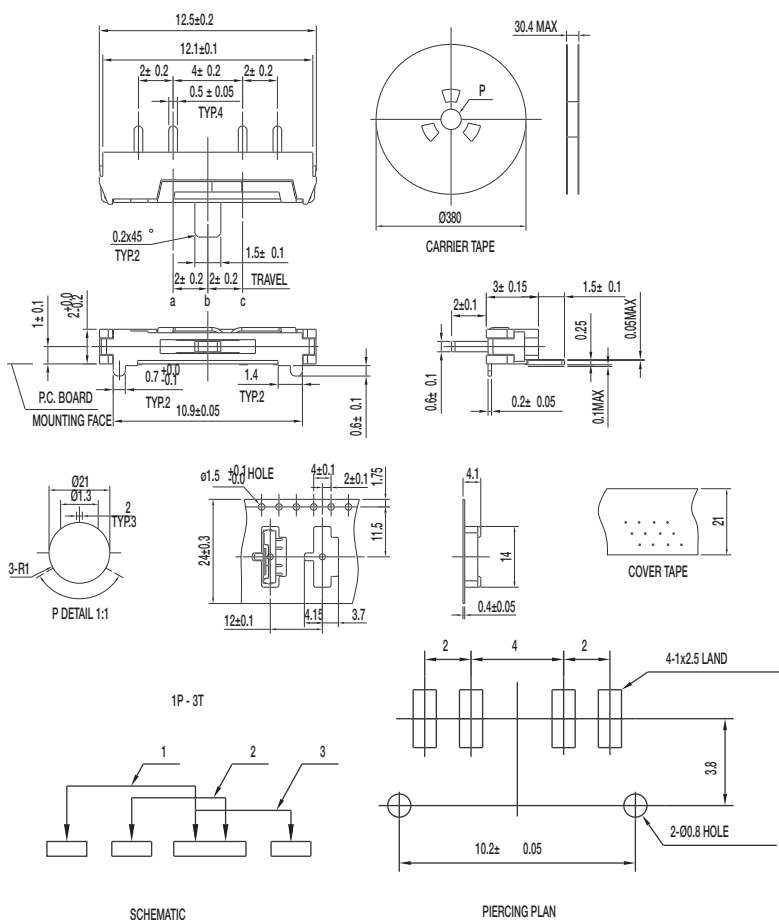

Specifications

CONTACT RATING: 0.3A @ 4 VDC
 INITIAL CONTACT RESISTANCE: 70 m ohms max.
 INSULATION RESISTANCE: 100 M ohms min.
 DIELECTRIC STRENGTH: 500 V AC (50-60 Hz) between open terminals and between the frame and terminal.
 OPERATING LIFE: 10,000 cycles with load
 OPERATING FORCE: 125 ± 50 gf (1.23 ± 0.49N)
 200 ± 50 gf (1.96 ± 0.49N)
 TRAVEL: 2 ± 0.3 mm
 OPERATING TEMPERATURE: -20°C to 70°C

Materials

HOUSE: LCP (UL 94V-0)
 KNOB: PA (UL 94V-0)
 FRAME: SUS
 CONTACT: Silver clad
 TERMINAL: Silver plated



Side

SK Series Miniature Slide Switches

SK-22D01-SG NS DPDT NON-SHORTING

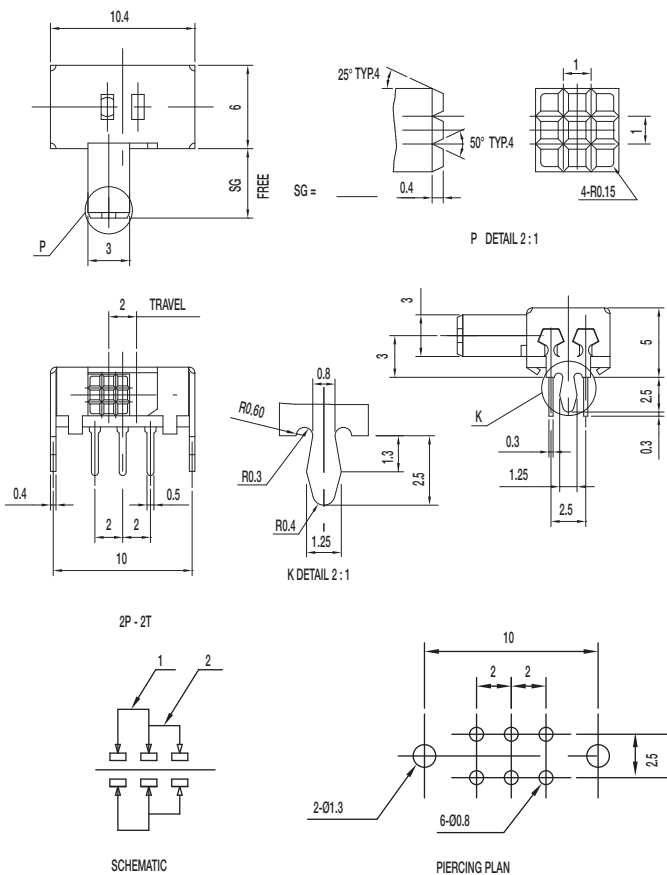

Specifications

CONTACT RATING: 0.3A @ 30 VDC
 INITIAL CONTACT RESISTANCE: 30 m ohms max.
 INSULATION RESISTANCE: 100 M ohms min.
 DIELECTRIC STRENGTH: 500 V AC (50-60 Hz) between open terminals and between the frame and terminal.
 OPERATING LIFE: 10,000 cycles with load
 OPERATING FORCE: 250 ± 100 gf (2.45 ± 0.98N)
 TRAVEL: 2 ± 0.3 mm
 OPERATING TEMPERATURE: -20°C to 70°C

Materials

KNOB: POM
 FRAME: SPCC
 CONTACT: Silver clad
 TERMINAL: Silver plated

SK-22D05-G NS DPDT NON-SHORTING

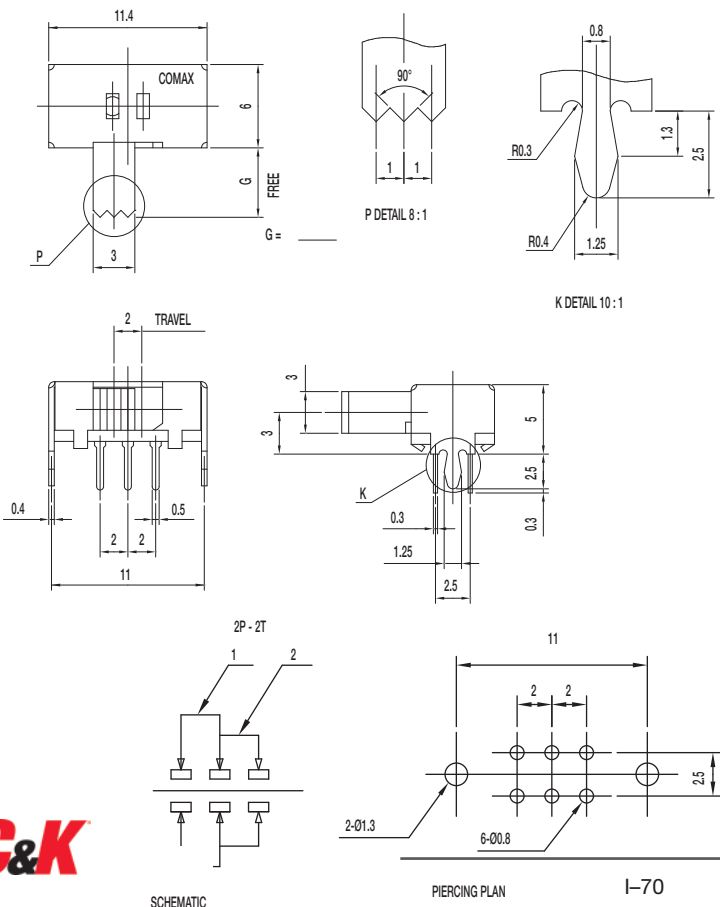

Specifications

CONTACT RATING: 0.3A @ 30 VDC
 INITIAL CONTACT RESISTANCE: 30 m ohms max.
 INSULATION RESISTANCE: 100 M ohms min.
 DIELECTRIC STRENGTH: 500 V AC (50-60 Hz) between open terminals and between the frame and terminal.
 OPERATING LIFE: 10,000 cycles with load
 OPERATING FORCE: 250 ± 100 gf (2.45 ± 0.98N)
 TRAVEL: 2 ± 0.3 mm
 OPERATING TEMPERATURE: -20°C to 70°C

Materials

KNOB: POM
 FRAME: SPCC
 CONTACT: Silver clad
 TERMINAL: Silver plated



Dimensions are shown:mm
 Specifications and dimensions subject to change

www.ck-components.com

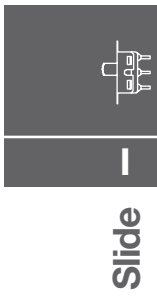

SK Series Miniature Slide Switches

SK-22D06-G NS DPDT NON-SHORTING

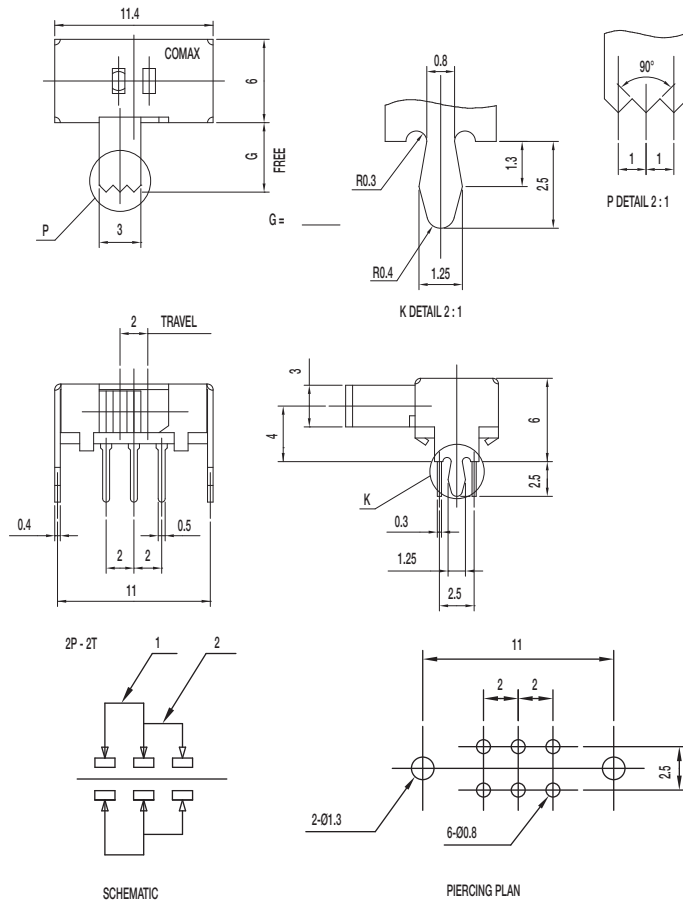

Specifications

CONTACT RATING: 0.3A @ 30 VDC
 INITIAL CONTACT RESISTANCE: 30 m ohms max.
 INSULATION RESISTANCE: 100 M ohms min.
 DIELECTRIC STRENGTH: 500 V AC (50-60 Hz) between open terminals and between the frame and terminal.
 OPERATING LIFE: 10,000 cycles with load
 OPERATING FORCE: 250 ± 100 gf (2.45 ± 0.98N)
 TRAVEL: 2 ± 0.3 mm
 OPERATING TEMPERATURE: -20°C to 70°C

Materials

KNOB: POM
 FRAME: SPCC
 CONTACT: Silver clad
 TERMINAL: Silver plated

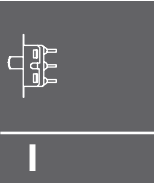

Side

SK-22H06-SG DPDT NON-SHORTING

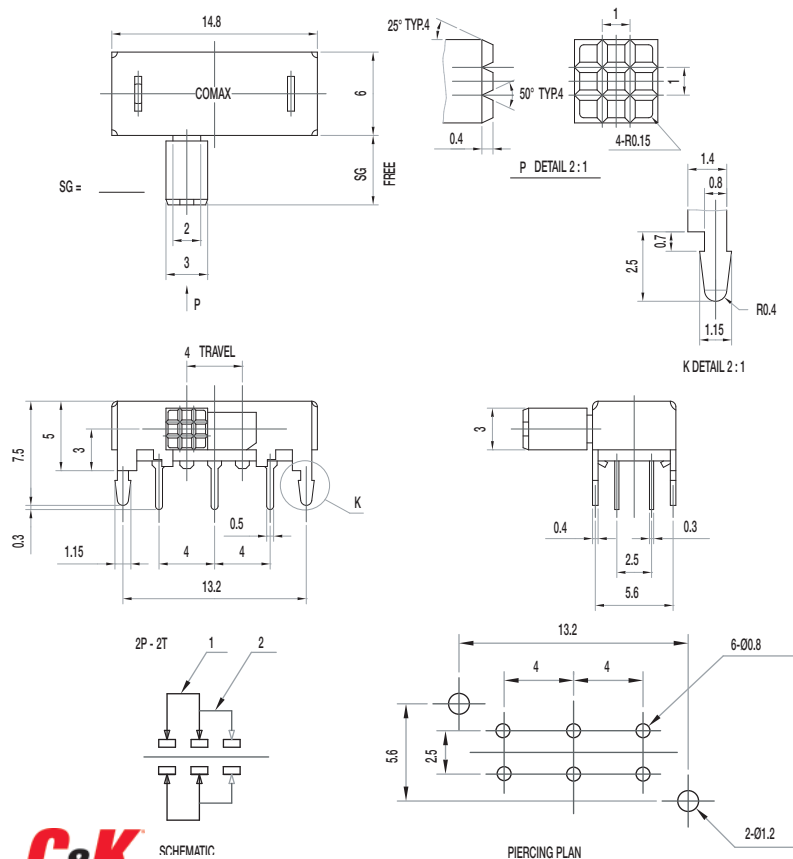

Specifications

CONTACT RATING: 0.3A @ 30 VDC
 INITIAL CONTACT RESISTANCE: 30 m ohms max.
 INSULATION RESISTANCE: 100 M ohms min.
 DIELECTRIC STRENGTH: 500 V AC (50-60 Hz) between open terminals and between the frame and terminal.
 OPERATING LIFE: 10,000 cycles with load
 OPERATING FORCE: 200 ± 100 gf (1.96 ± 0.98N)
 TRAVEL: 4 ± 0.3 mm
 OPERATING TEMPERATURE: -20°C to 70°C

Materials

KNOB: POM
 FRAME: SPCC
 CONTACT: Silver clad
 TERMINAL: Silver plated



SCHMATIC

Dimensions are shown: mm
 Specifications and dimensions subject to change

SK Series Miniature Slide Switches

SK-23D05-G 2P3T

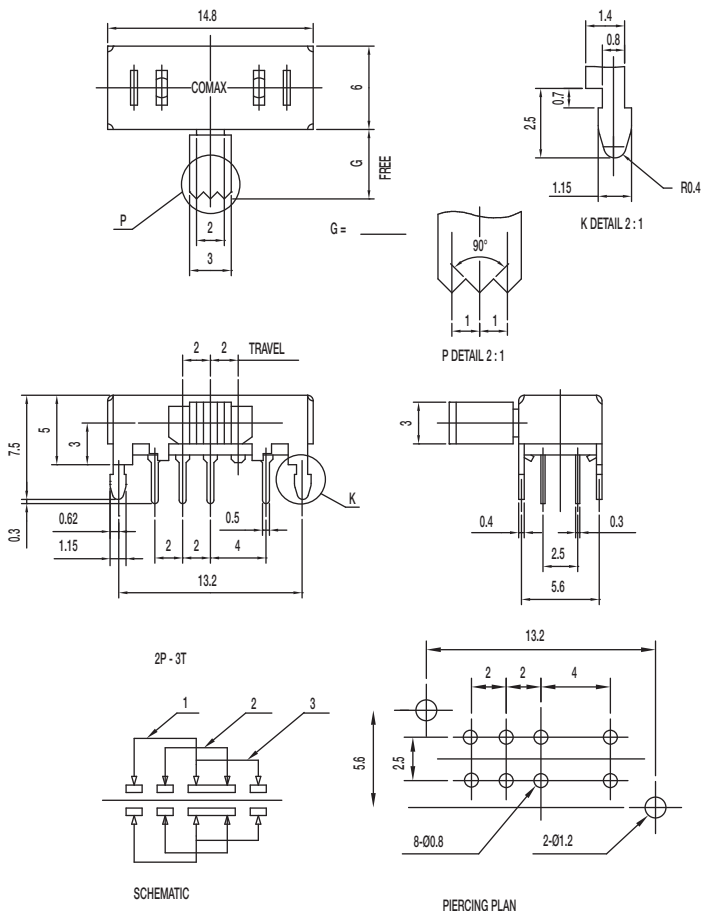

Specifications

CONTACT RATING: 0.3A @ 30 VDC
 INITIAL CONTACT RESISTANCE: 30 m ohms max.
 INSULATION RESISTANCE: 100 M ohms min.
 DIELECTRIC STRENGTH: 500 V AC (50-60 Hz) between open terminals and between the frame and terminal.
 OPERATING LIFE: 10,000 cycles with load
 OPERATING FORCE: 200 ± 100 gf (1.96 ± 0.98N)
 250 ± 100 gf (2.45 ± 0.98N)
 TRAVEL: 2 ± 0.3 mm
 OPERATING TEMPERATURE: -20°C to 70°C

Materials

KNOB: POM
 FRAME: SPCC
 CONTACT: Silver clad
 TERMINAL: Silver plated

SK-42D05-SG NS 4P2T NON-SHORTING

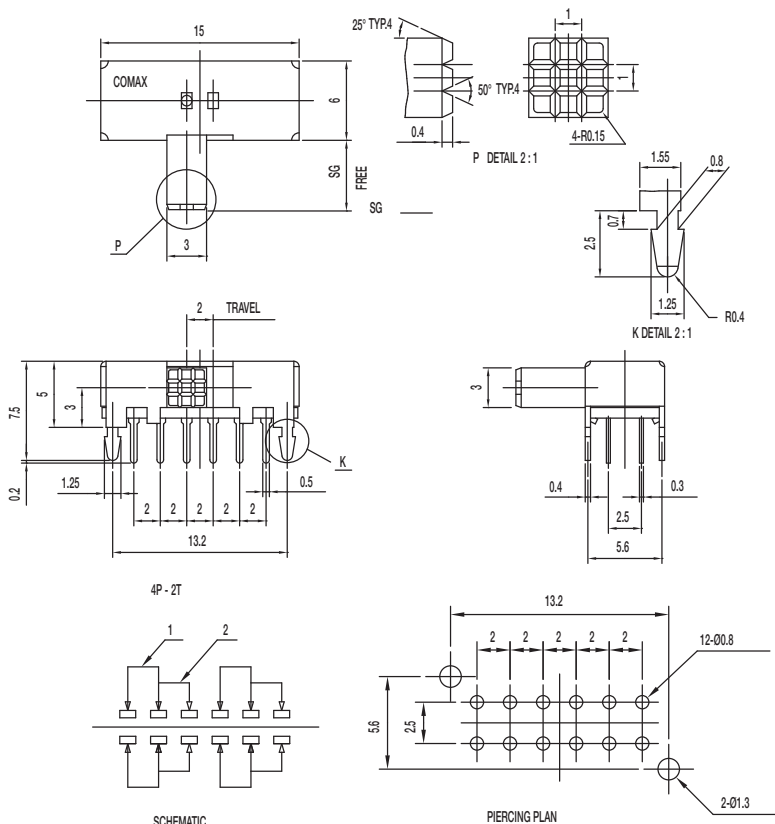

Specifications

CONTACT RATING: 0.3A @ 30 VDC
 INITIAL CONTACT RESISTANCE: 30 m ohms max.
 INSULATION RESISTANCE: 100 M ohms min.
 DIELECTRIC STRENGTH: 500 V AC (50-60 Hz) between open terminals and between the frame and terminal.
 OPERATING LIFE: 10,000 cycles with load
 OPERATING FORCE: 250 ± 100 gf (2.45 ± 0.98N)
 TRAVEL: 2 ± 0.3 mm
 OPERATING TEMPERATURE: -20°C to 70°C

Materials

KNOB: POM
 FRAME: SPCC
 CONTACT: Silver clad
 TERMINAL: Silver plated

Dimensions are shown: mm
 Specifications and dimensions subject to change

SK Series Miniature Slide Switches

SK-43D05-SG 4P3T

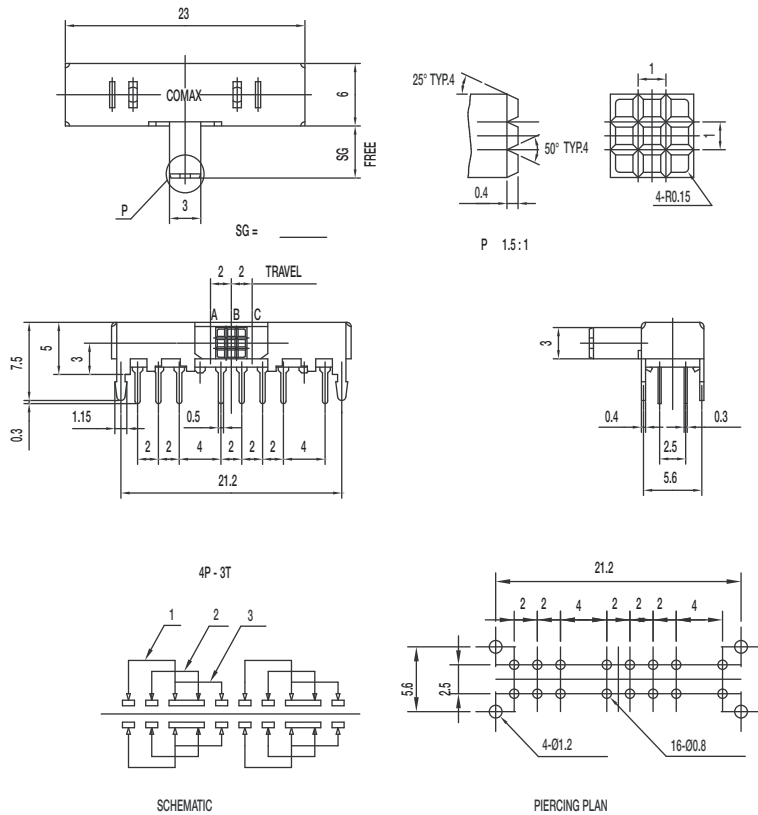

Specifications

CONTACT RATING: 0.3A @ 30 VDC
 INITIAL CONTACT RESISTANCE: 30 m ohms max.
 INSULATION RESISTANCE: 100 M ohms min.
 DIELECTRIC STRENGTH: 500 V AC (50-60 Hz) between open terminals and between the frame and terminal.
 OPERATING LIFE: 10,000 cycles with load
 OPERATING FORCE: 200 ± 100 gf (1.96 ± 0.98N)
 300 ± 100 gf (2.94 ± 0.98N)
 TRAVEL: 2 ± 0.3 mm
 OPERATING TEMPERATURE: -20°C to 70°C

Materials

KNOB: POM
 FRAME: SPCC
 CONTACT: Silver clad
 TERMINAL: Silver plated

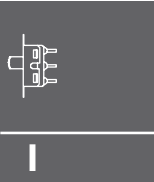

Side

SK-42H03-G 4P2T NON-SHORTING

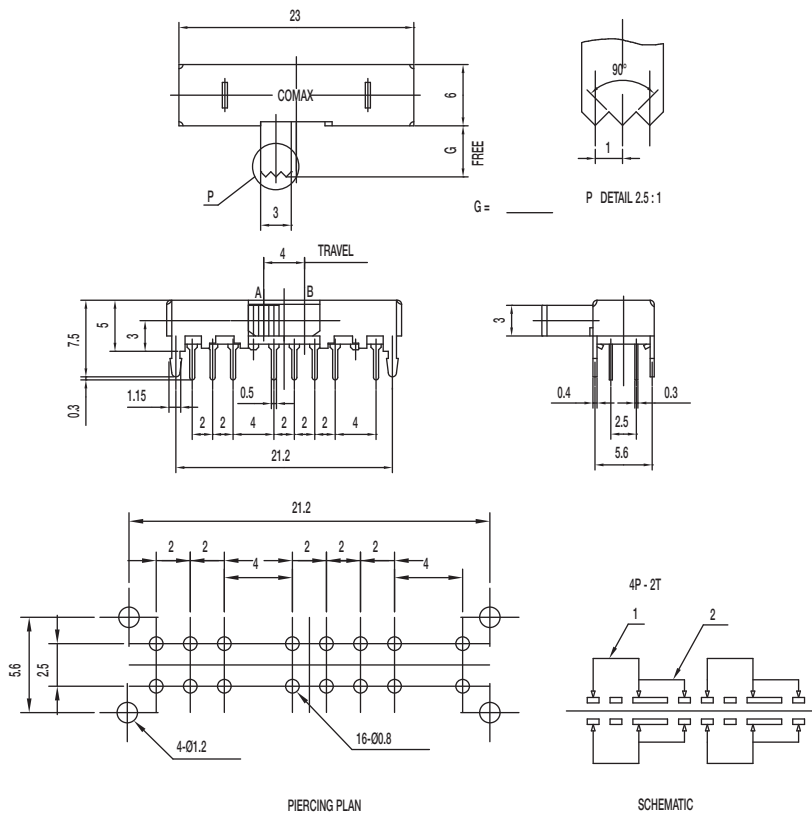

Specifications

CONTACT RATING: 0.3A @ 30 VDC
 INITIAL CONTACT RESISTANCE: 30 m ohms max.
 INSULATION RESISTANCE: 100 M ohms min.
 DIELECTRIC STRENGTH: 500 V AC (50-60 Hz) between open terminals and between the frame and terminal.
 OPERATING LIFE: 10,000 cycles with load
 OPERATING FORCE: 200 ± 100 gf (1.96 ± 0.98N)
 TRAVEL: 4 ± 0.3 mm
 OPERATING TEMPERATURE: -20°C to 70°C

Materials

KNOB: POM
 FRAME: SPCC
 CONTACT: Silver clad
 TERMINAL: Silver plated



Dimensions are shown: mm
 Specifications and dimensions subject to change

SK Series Miniature Slide Switches

SK-22D28-G NS DPDT NON-SHORTING

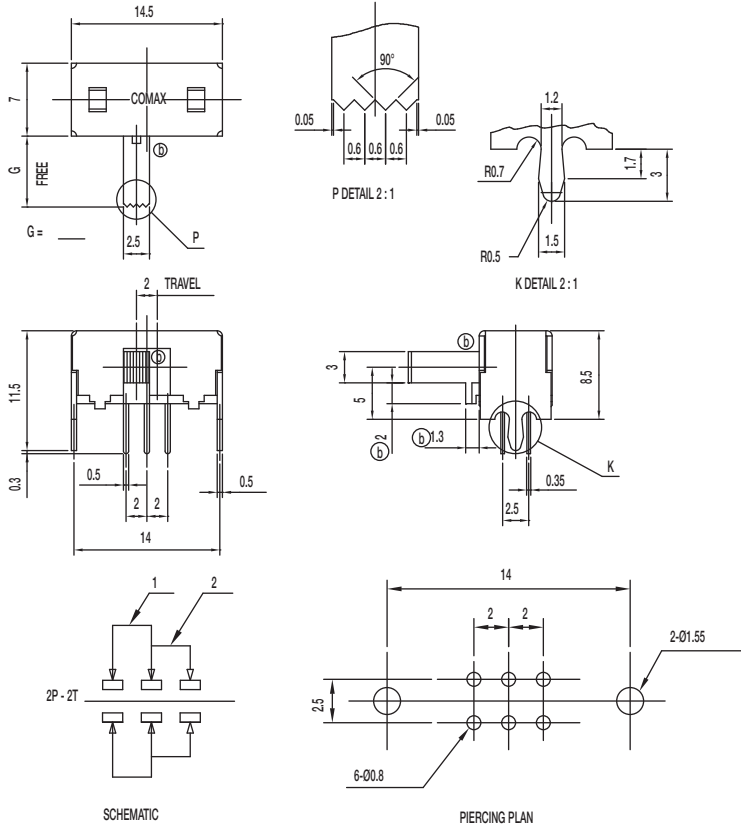

Specifications

CONTACT RATING: 0.3A @ 30 VDC
 INITIAL CONTACT RESISTANCE: 30 m ohms max.
 INSULATION RESISTANCE: 100 M ohms min.
 DIELECTRIC STRENGTH: 500 V AC (50-60 Hz) between open terminals and between the frame and terminal.
 OPERATING LIFE: 10,000 cycles with load
 OPERATING FORCE: 200 ± 100 gf (1.96 ± 0.98N)
 TRAVEL: 2 ± 0.3 mm
 OPERATING TEMPERATURE: -20°C to 70°C

Materials

KNOB: POM
 FRAME: SPCC
 CONTACT: Silver clad
 TERMINAL: Silver plated

SK-23D28-G NS 2P3T NON-SHORTING

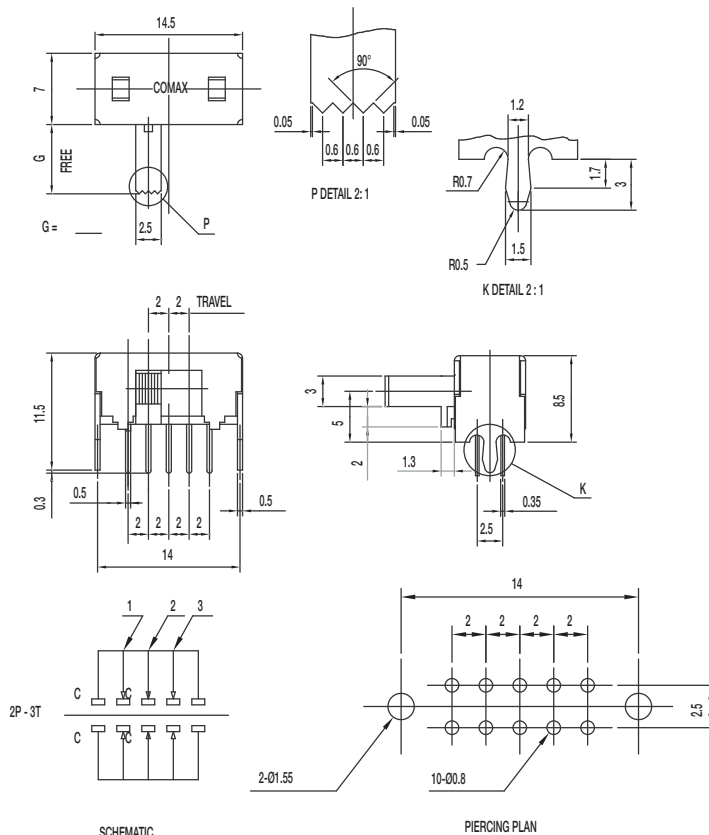

Specifications

CONTACT RATING: 0.3A @ 30 VDC
 INITIAL CONTACT RESISTANCE: 30 m ohms max.
 INSULATION RESISTANCE: 100 M ohms min.
 DIELECTRIC STRENGTH: 500 V AC (50-60 Hz) between open terminals and between the frame and terminal.
 OPERATING LIFE: 10,000 cycles with load
 OPERATING FORCE: 200 ± 100 gf (1.96 ± 0.98N)
 300 ± 150 gf (2.94 ± 1.47N)
 TRAVEL: 2 ± 0.3 mm
 OPERATING TEMPERATURE: -20°C to 70°C

Materials

KNOB: POM
 FRAME: SPCC
 CONTACT: Silver clad
 TERMINAL: Silver plated



Dimensions are shown: mm
 Specifications and dimensions subject to change

SK Series Miniature Slide Switches

SK-24D18-DG NS 2P4T NON-SHORTING

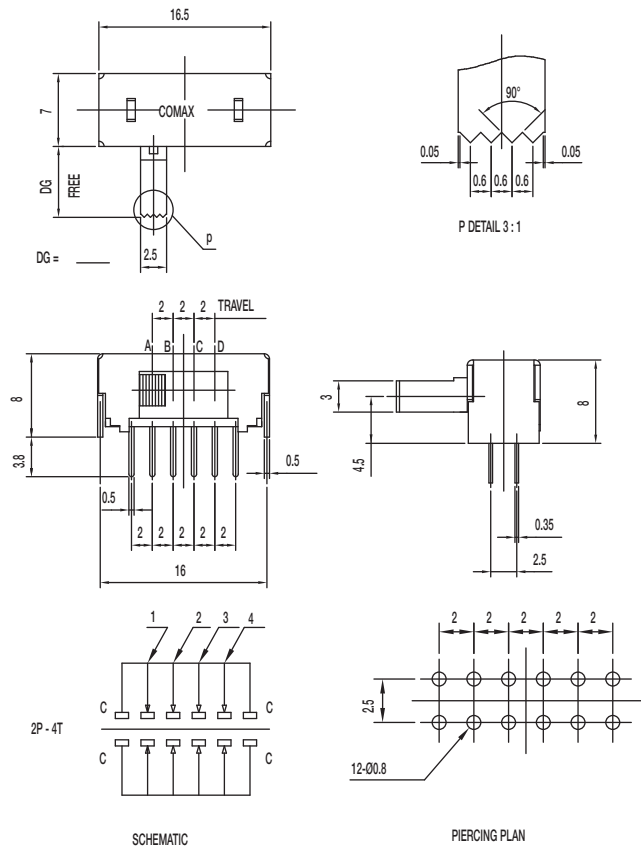

Specifications

CONTACT RATING: 0.3A @ 30 VDC
 INITIAL CONTACT RESISTANCE: 30 m ohms max.
 INSULATION RESISTANCE: 100 M ohms min.
 DIELECTRIC STRENGTH: 500 V AC (50-60 Hz) between open terminals and between the frame and terminal.
 OPERATING LIFE: 10,000 cycles with load
 OPERATING FORCE: 200 ± 100 gf (1.96 ± 0.98N)
 250 ± 100 gf (2.45 ± 0.98N); 300 ± 150 gf (2.94 ± 1.47N)
 TRAVEL: 2 ± 0.3 mm
 OPERATING TEMPERATURE: -20°C to 70°C

Materials

KNOB: POM
 FRAME: SPCC
 CONTACT: Silver clad
 TERMINAL: Silver plated

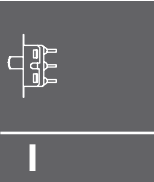

Side

SK-24D28-G NS 2P4T NON-SHORTING

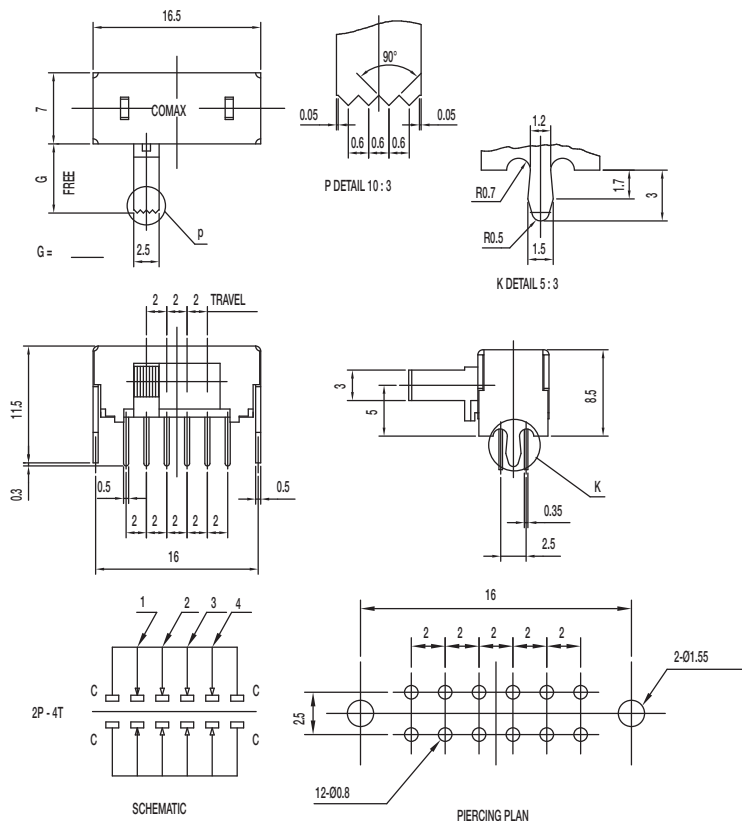

Specifications

CONTACT RATING: 0.3A @ 30 VDC
 INITIAL CONTACT RESISTANCE: 30 m ohms max.
 INSULATION RESISTANCE: 100 M ohms min.
 DIELECTRIC STRENGTH: 500 V AC (50-60 Hz) between open terminals and between the frame and terminal.
 OPERATING LIFE: 10,000 cycles with load
 OPERATING FORCE: 200 ± 100 gf (1.96 ± 0.98N)
 250 ± 100 gf (2.45 ± 0.98N); 300 ± 150 gf (2.94 ± 1.47N)
 TRAVEL: 2 ± 0.3 mm
 OPERATING TEMPERATURE: -20°C to 70°C

Materials

KNOB: POM
 FRAME: SPCC
 CONTACT: Silver clad
 TERMINAL: Silver plated



Dimensions are shown: mm
 Specifications and dimensions subject to change

SK Series Miniature Slide Switches

SK-42D28-G NS 4P2T NON-SHORTING

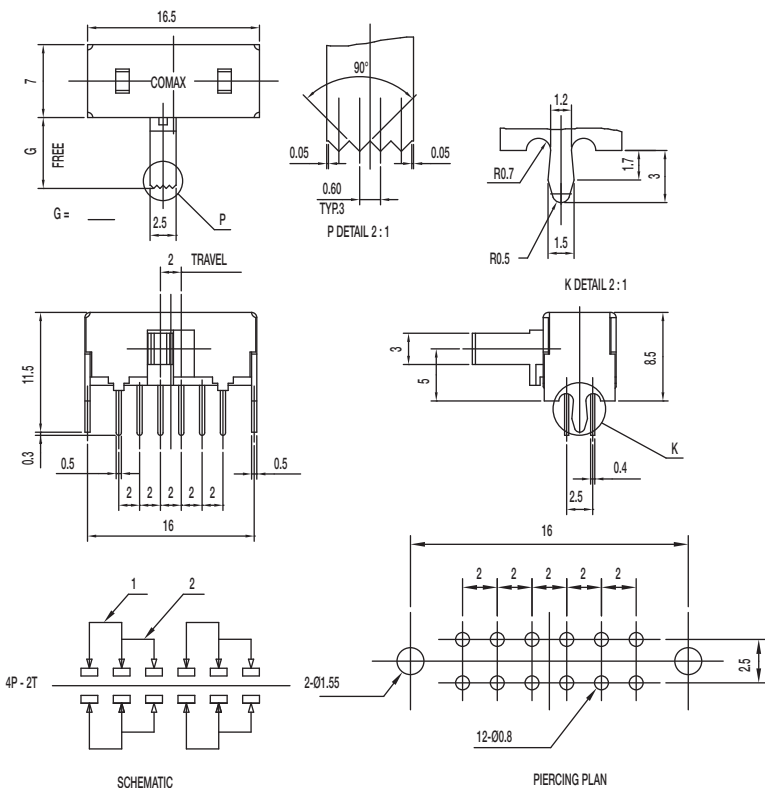

Specifications

CONTACT RATING: 0.3A @ 30 VDC
 INITIAL CONTACT RESISTANCE: 30 m ohms max.
 INSULATION RESISTANCE: 100 M ohms min.
 DIELECTRIC STRENGTH: 500 V AC (50-60 Hz) between open terminals and between the frame and terminal.
 OPERATING LIFE: 10,000 cycles with load
 OPERATING FORCE: 200 ± 100 gf (1.96 ± 0.98N)
 TRAVEL: 2 ± 0.3 mm
 OPERATING TEMPERATURE: -20°C to 70°C

Materials

KNOB: POM
 FRAME: SPCC
 CONTACT: Silver clad
 TERMINAL: Silver plated

SK-43D28-G NS 4P3T NON-SHORTING

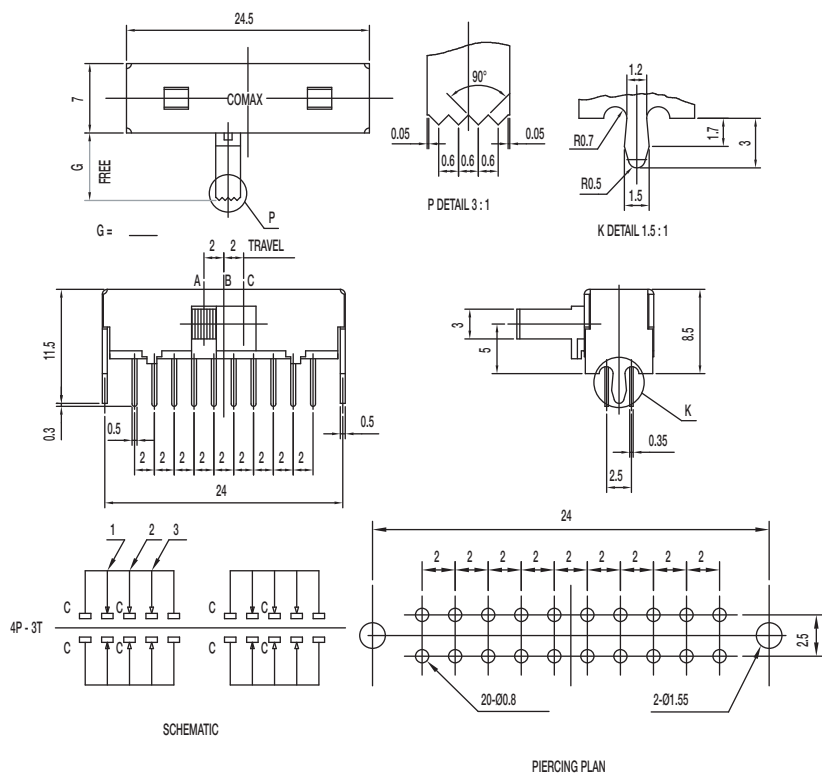

Specifications

CONTACT RATING: 0.3A @ 30 VDC
 INITIAL CONTACT RESISTANCE: 30 m ohms max.
 INSULATION RESISTANCE: 100 M ohms min.
 DIELECTRIC STRENGTH: 500 V AC (50-60 Hz) between open terminals and between the frame and terminal.
 OPERATING LIFE: 10,000 cycles with load
 OPERATING FORCE: 200 ± 100 gf (1.96 ± 0.98N)
 300 ± 150 gf (2.94 ± 1.47N)
 TRAVEL: 2 ± 0.3 mm
 OPERATING TEMPERATURE: -20°C to 70°C

Materials

KNOB: POM
 FRAME: SPCC
 CONTACT: Silver clad
 TERMINAL: Silver plated



Dimensions are shown: mm
 Specifications and dimensions subject to change

SK Series Miniature Slide Switches

SK-12F28-G NS 1P2T NON-SHORTING

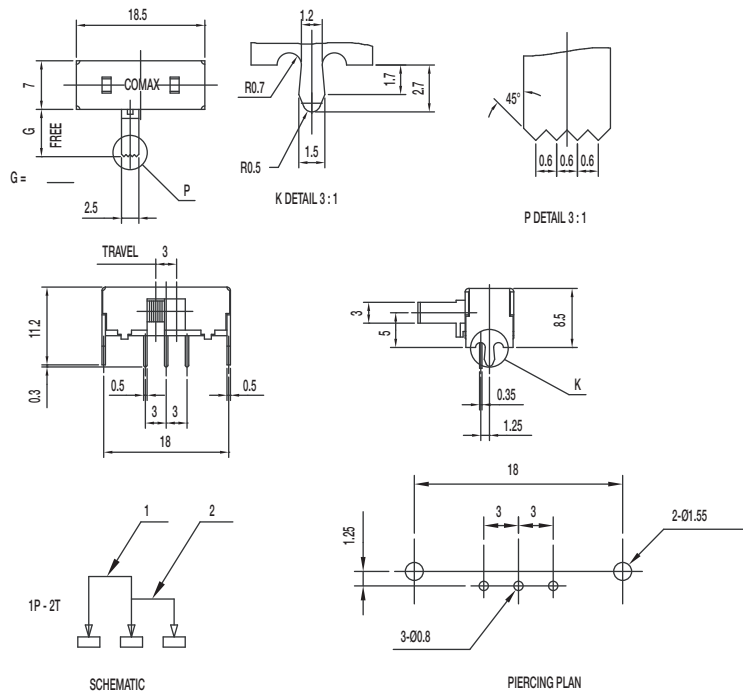

Specifications

CONTACT RATING: 0.3A @ 30 VDC
 INITIAL CONTACT RESISTANCE: 30 m ohms max.
 INSULATION RESISTANCE: 100 M ohms min.
 DIELECTRIC STRENGTH: 500 V AC (50-60 Hz) between open terminals and between the frame and terminal.
 OPERATING LIFE: 10,000 cycles with load
 OPERATING FORCE: 200 ± 100 gf (1.96 ± 0.98N)
 TRAVEL: 3 ± 0.3 mm
 OPERATING TEMPERATURE: -20°C to 70°C

Materials

KNOB: POM
 FRAME: SPCC
 CONTACT: Silver clad
 TERMINAL: Silver plated

SK-22F28-G NS DPDT NON-SHORTING

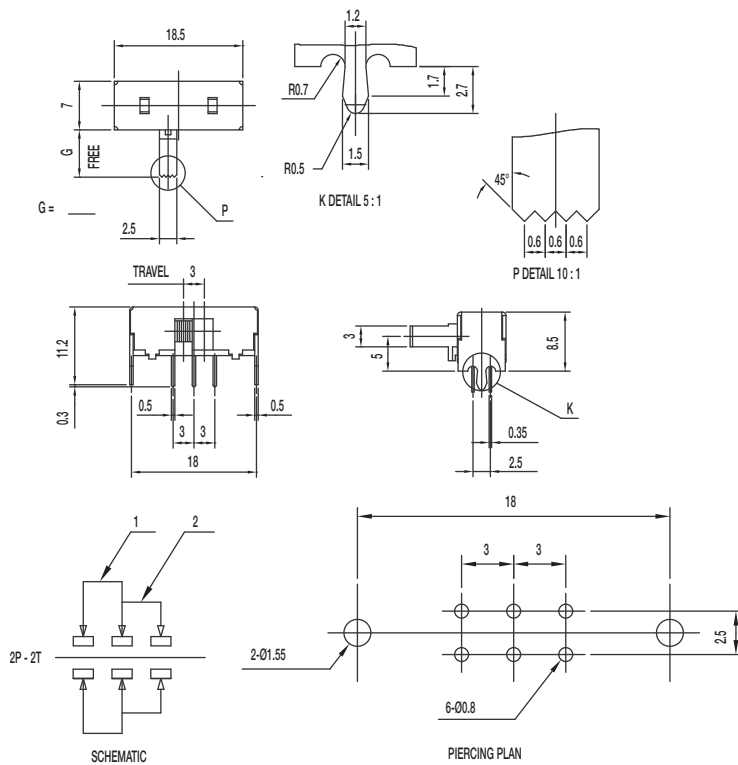

Specifications

CONTACT RATING: 0.3A @ 30 VDC
 INITIAL CONTACT RESISTANCE: 30 m ohms max.
 INSULATION RESISTANCE: 100 M ohms min.
 DIELECTRIC STRENGTH: 500 V AC (50-60 Hz) between open terminals and between the frame and terminal.
 OPERATING LIFE: 10,000 cycles with load
 OPERATING FORCE: 200 ± 100 gf (1.96 ± 0.98N)
 TRAVEL: 3 ± 0.3 mm
 OPERATING TEMPERATURE: -20°C to 70°C

Materials

KNOB: POM
 FRAME: SPCC
 CONTACT: Silver clad
 TERMINAL: Silver plated

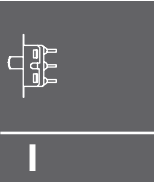

Side

SK Series Miniature Slide Switches

SK-23F28-G NS 2P3T NON-SHORTING

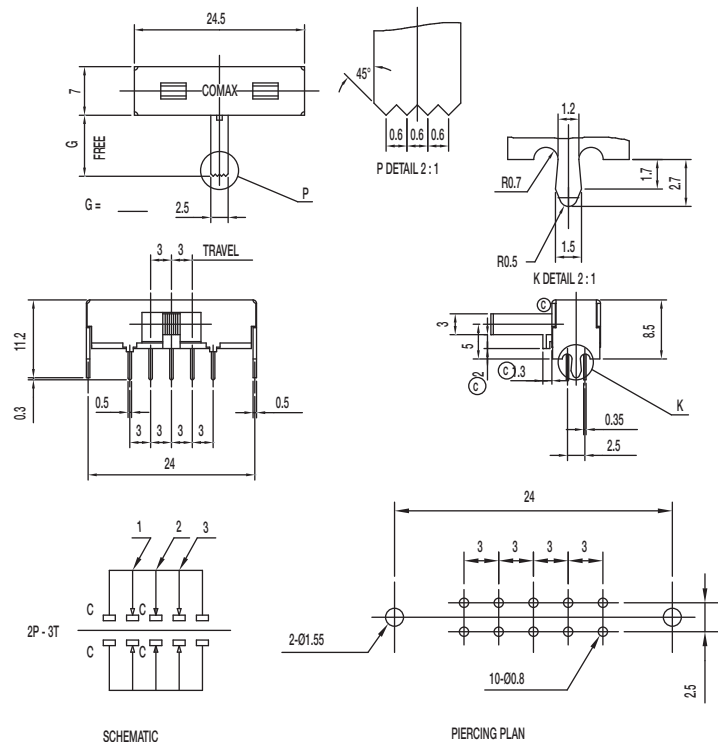

Specifications

CONTACT RATING: 0.3A @ 30 VDC
 INITIAL CONTACT RESISTANCE: 30 m ohms max.
 INSULATION RESISTANCE: 100 M ohms min.
 DIELECTRIC STRENGTH: 500 V AC (50-60 Hz) between open terminals and between the frame and terminal.
 OPERATING LIFE: 10,000 cycles with load
 OPERATING FORCE: 150 ± 80 gf (1.47 ± 0.78N)
 200 ± 100 gf (1.96 ± 0.98N)
 TRAVEL: 3 ± 0.3 mm
 OPERATING TEMPERATURE: -20°C to 70°C

Materials

KNOB: POM
 FRAME: SPCC
 CONTACT: Silver clad
 TERMINAL: Silver plated

SK-24F28-G NS 2P4T NON-SHORTING

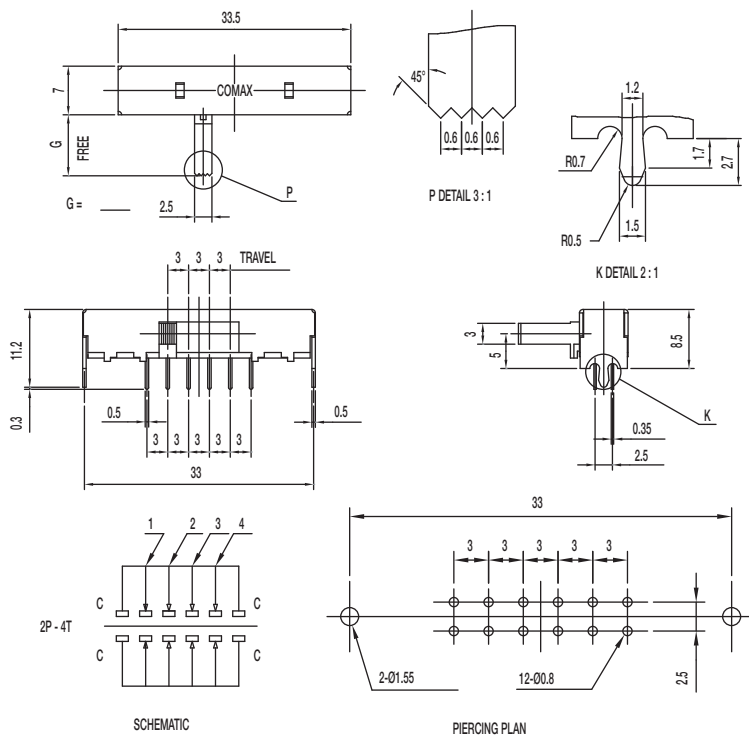

Specifications

CONTACT RATING: 0.3A @ 30 VDC
 INITIAL CONTACT RESISTANCE: 30 m ohms max.
 INSULATION RESISTANCE: 100 M ohms min.
 DIELECTRIC STRENGTH: 500 V AC (50-60 Hz) between open terminals and between the frame and terminal.
 OPERATING LIFE: 10,000 cycles with load
 OPERATING FORCE: 200 ± 100 gf (1.96 ± 0.98N)
 250 ± 100 gf (2.45 ± 0.98N)
 TRAVEL: 3 ± 0.3 mm
 OPERATING TEMPERATURE: -20°C to 70°C

Materials

KNOB: POM
 FRAME: SPCC
 CONTACT: Silver clad
 TERMINAL: Silver plated

SK Series Miniature Slide Switches

SK-42F28-G NS 2P4T NON-SHORTING

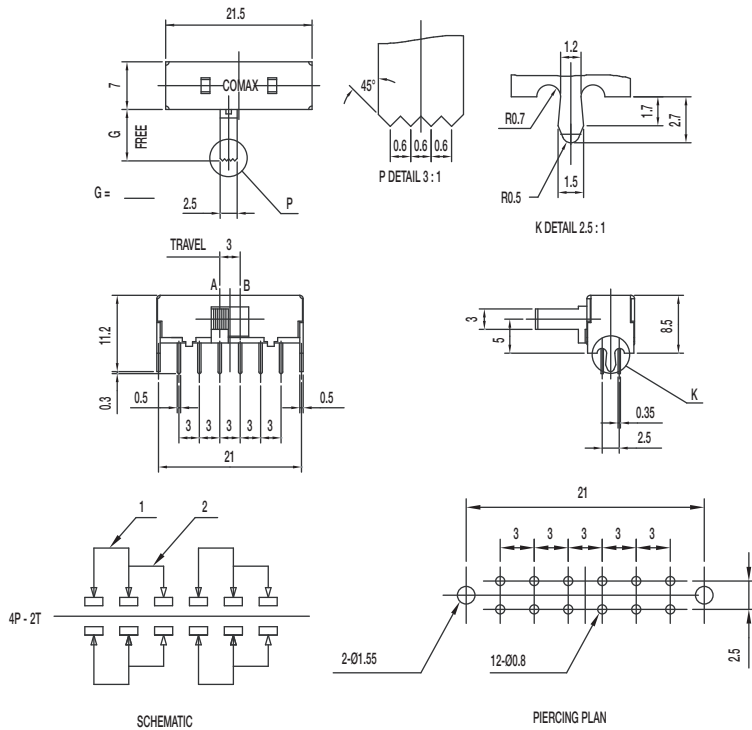

Specifications

CONTACT RATING: 0.3A @ 30 VDC
 INITIAL CONTACT RESISTANCE: 30 m ohms max.
 INSULATION RESISTANCE: 100 M ohms min.
 DIELECTRIC STRENGTH: 500 V AC (50-60 Hz) between open terminals and between the frame and terminal.
 OPERATING LIFE: 10,000 cycles with load
 OPERATING FORCE: 200 ± 100 gf (1.96 ± 0.98 N)
 250 ± 100 gf (2.45 ± 0.98 N)
 TRAVEL: 3 ± 0.3 mm
 OPERATING TEMPERATURE: -20°C to 70°C

Materials

KNOB: POM
 FRAME: SPCC
 CONTACT: Silver clad
 TERMINAL: Silver plated

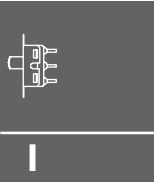

Side

SK-12H04-G NS 1P2T NON-SHORTING

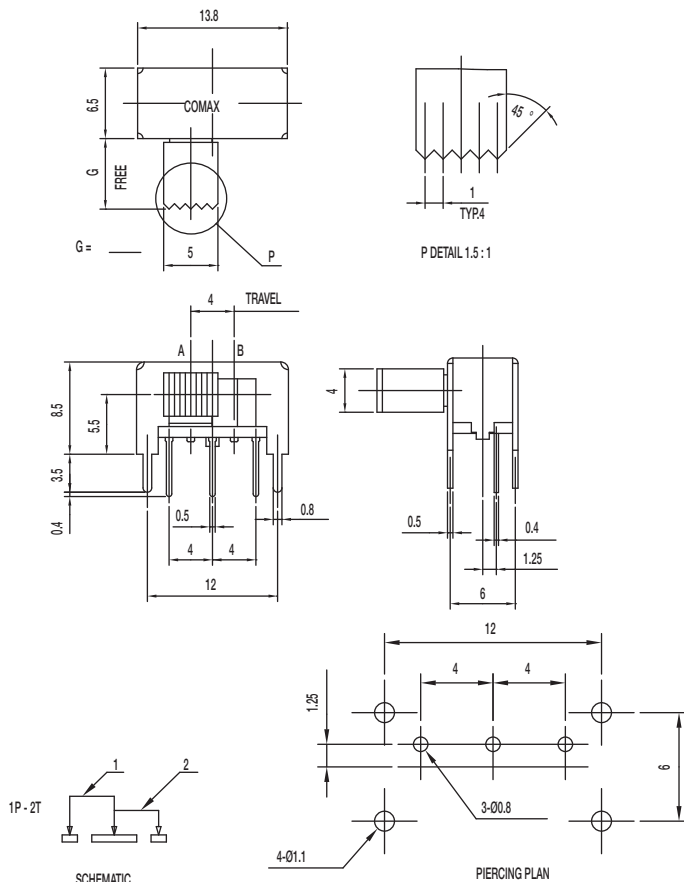

Specifications

CONTACT RATING: 0.3A @ 30 VDC
 INITIAL CONTACT RESISTANCE: 30 m ohms max.
 INSULATION RESISTANCE: 100 M ohms min.
 DIELECTRIC STRENGTH: 500 V AC (50-60 Hz) between open terminals and between the frame and terminal.
 OPERATING LIFE: 10,000 cycles with load
 OPERATING FORCE: 250 ± 100 gf (2.45 ± 0.98 N)
 TRAVEL: 4 ± 0.3 mm
 OPERATING TEMPERATURE: -20°C to 70°C

Materials

KNOB: POM
 FRAME: SPCC
 CONTACT: Silver clad
 TERMINAL: Silver plated



Dimensions are shown: mm
 Specifications and dimensions subject to change

SK Series Miniature Slide Switches

SK-22H04-G NS DPDT NON-SHORTING

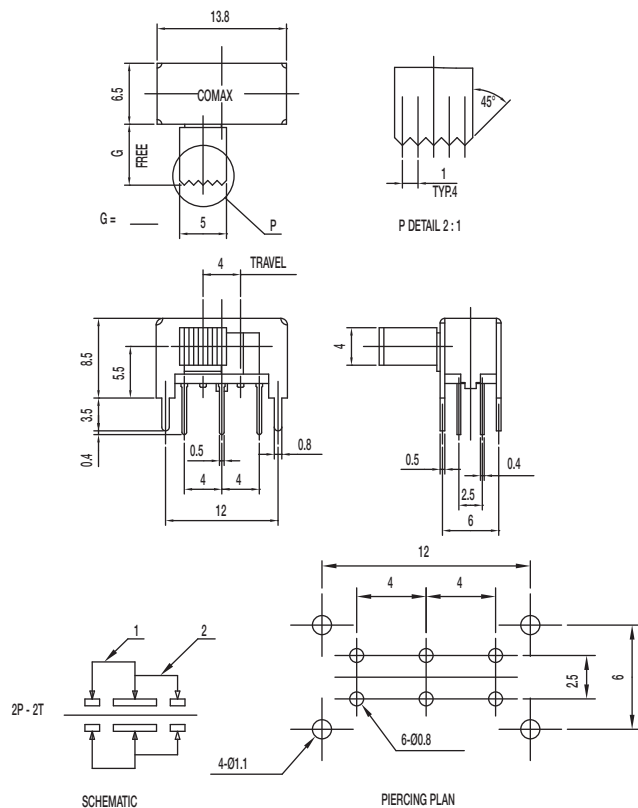

Specifications

- CONTACT RATING: 0.3A @ 30 VDC
- INITIAL CONTACT RESISTANCE: 30 m ohms max.
- INSULATION RESISTANCE: 100 M ohms min.
- DIELECTRIC STRENGTH: 500 V AC (50-60 Hz) between open terminals and between the frame and terminal.
- OPERATING LIFE: 10,000 cycles with load
- OPERATING FORCE: 250 ± 100 gf (2.45 ± 0.98N)
- TRAVEL: 4 ± 0.3 mm
- OPERATING TEMPERATURE: -20°C to 70°C

Materials

- KNOB: POM
- FRAME: SPCC
- CONTACT: Silver clad
- TERMINAL: Silver plated

SK-22H24-G NS DPDT NON-SHORTING

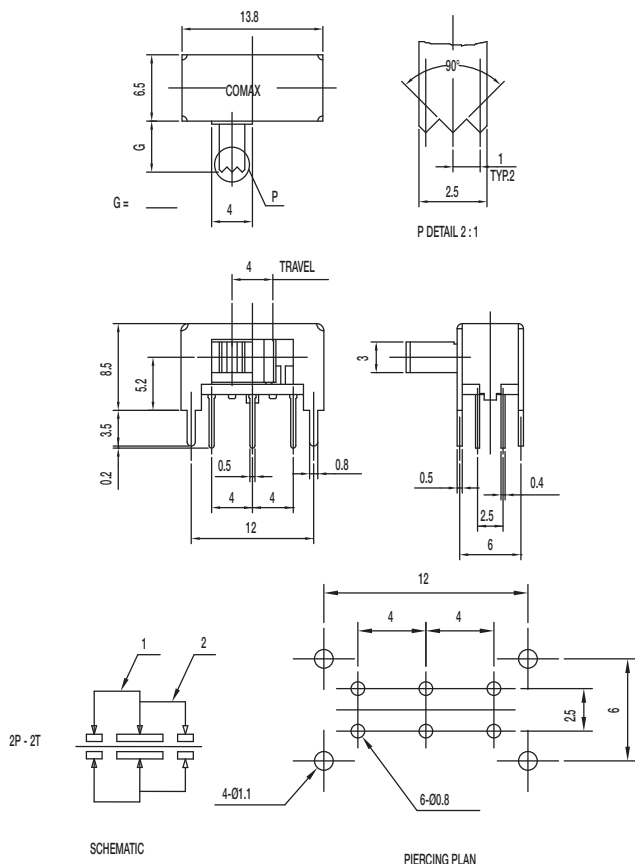

Specifications

- CONTACT RATING: 0.3A @ 30 VDC
- INITIAL CONTACT RESISTANCE: 30 m ohms max.
- INSULATION RESISTANCE: 100 M ohms min.
- DIELECTRIC STRENGTH: 500 V AC (50-60 Hz) between open terminals and between the frame and terminal.
- OPERATING LIFE: 10,000 cycles with load
- OPERATING FORCE: 250 ± 100 gf (2.45 ± 0.98N)
- TRAVEL: 4 ± 0.3 mm
- OPERATING TEMPERATURE: -20°C to 70°C

Materials

- KNOB: POM
- FRAME: SPCC
- CONTACT: Silver clad
- TERMINAL: Silver plated



Dimensions are shown: mm
Specifications and dimensions subject to change

Slide

SK Series Miniature Slide Switches

SK-22H44-G NS DPDT NON-SHORTING

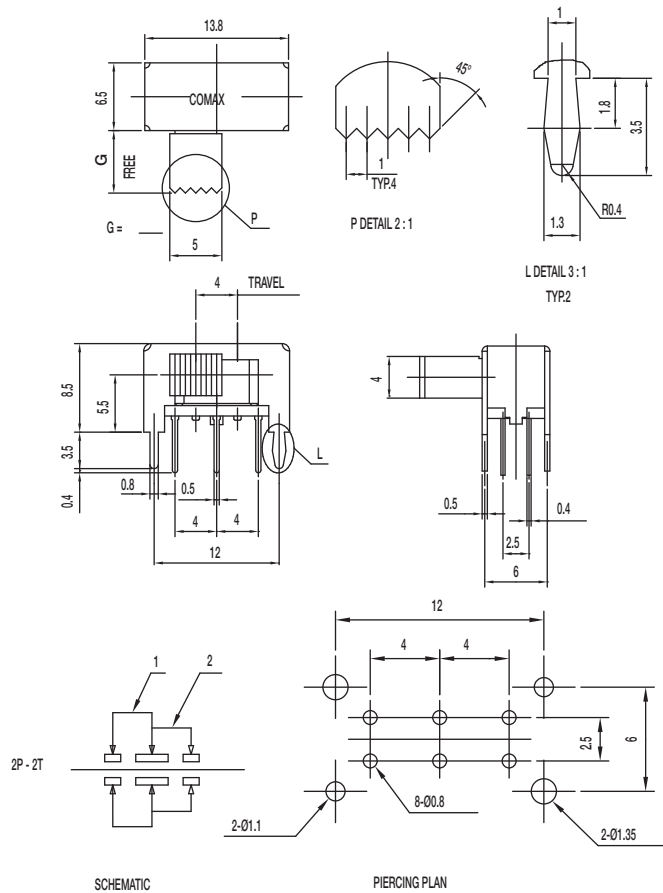

SK-23D04-G 2P3T

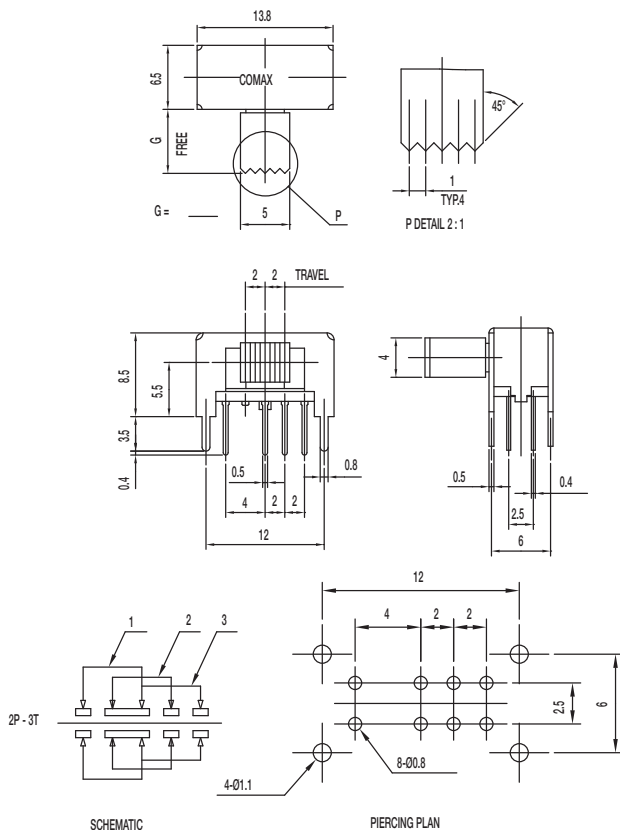

Specifications

CONTACT RATING: 0.3A @ 30 VDC
 INITIAL CONTACT RESISTANCE: 30 m ohms max.
 INSULATION RESISTANCE: 100 M ohms min.
 DIELECTRIC STRENGTH: 500 V AC (50-60 Hz) between open terminals and between the frame and terminal.
 OPERATING LIFE: 10,000 cycles with load
 OPERATING FORCE: 250 ± 150 gf (2.45 ± 1.47N)
 TRAVEL: 4 ± 0.3 mm
 OPERATING TEMPERATURE: -20°C to 70°C

Materials

KNOB: POM
 FRAME: SPCC
 CONTACT: Silver clad
 TERMINAL: Silver plated

Specifications

CONTACT RATING: 0.3A @ 30 VDC
 INITIAL CONTACT RESISTANCE: 30 m ohms max.
 INSULATION RESISTANCE: 100 M ohms min.
 DIELECTRIC STRENGTH: 500 V AC (50-60 Hz) between open terminals and between the frame and terminal.
 OPERATING LIFE: 10,000 cycles with load
 OPERATING FORCE: 200 ± 100 gf (1.96 ± 0.98N)
 300 ± 150 gf (2.94 ± 1.47N)
 TRAVEL: 2 ± 0.3 mm
 OPERATING TEMPERATURE: -20°C to 70°C

Materials

KNOB: POM
 FRAME: SPCC
 CONTACT: Silver clad
 TERMINAL: Silver plated



Dimensions are shown: mm
 Specifications and dimensions subject to change

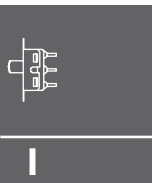

Side

SK Series Miniature Slide Switches

SK-23D23-G NS 2P3T NON-SHORTING

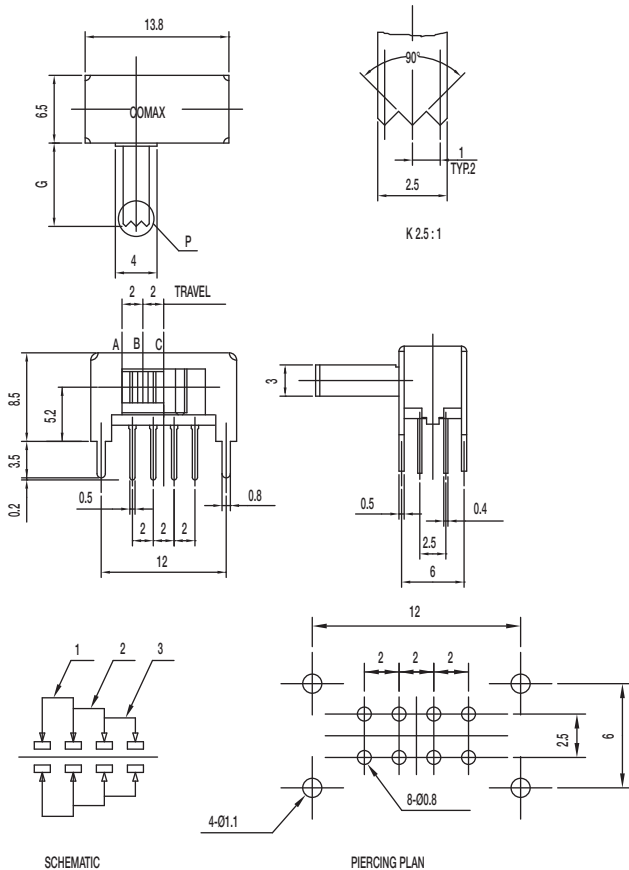

Specifications

CONTACT RATING: 0.3A @ 30 VDC
 INITIAL CONTACT RESISTANCE: 30 m ohms max.
 INSULATION RESISTANCE: 100 M ohms min.
 DIELECTRIC STRENGTH: 500 V AC (50-60 Hz) between open terminals and between the frame and terminal.
 OPERATING LIFE: 10,000 cycles with load
 OPERATING FORCE: 200 ± 100 gf (1.96 ± 0.98N)
 300 ± 150 gf (2.94 ± 1.47N)
 TRAVEL: 2 ± 0.3 mm
 OPERATING TEMPERATURE: -20°C to 70°C

Materials

KNOB: POM
 FRAME: SPCC
 CONTACT: Silver clad
 TERMINAL: Silver plated

SK-23D24-G 2P3T

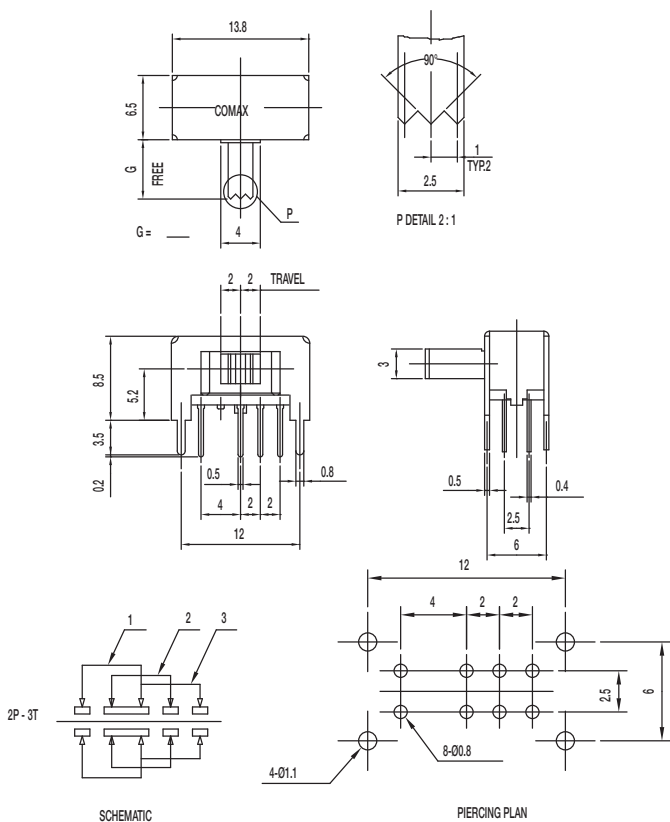

Specifications

CONTACT RATING: 0.3A @ 30 VDC
 INITIAL CONTACT RESISTANCE: 30 m ohms max.
 INSULATION RESISTANCE: 100 M ohms min.
 DIELECTRIC STRENGTH: 500 V AC (50-60 Hz) between open terminals and between the frame and terminal.
 OPERATING LIFE: 10,000 cycles with load
 OPERATING FORCE: 200 ± 100 gf (1.96 ± 0.98N)
 300 ± 150 gf (2.94 ± 1.47N)
 TRAVEL: 2 ± 0.3 mm
 OPERATING TEMPERATURE: -20°C to 70°C

Materials

KNOB: POM
 FRAME: SPCC
 CONTACT: Silver clad
 TERMINAL: Silver plated



Dimensions are shown: mm
 Specifications and dimensions subject to change

SK Series Miniature Slide Switches

SK-23D44-G K 2P3T NON-SHORTING AND SHORTING

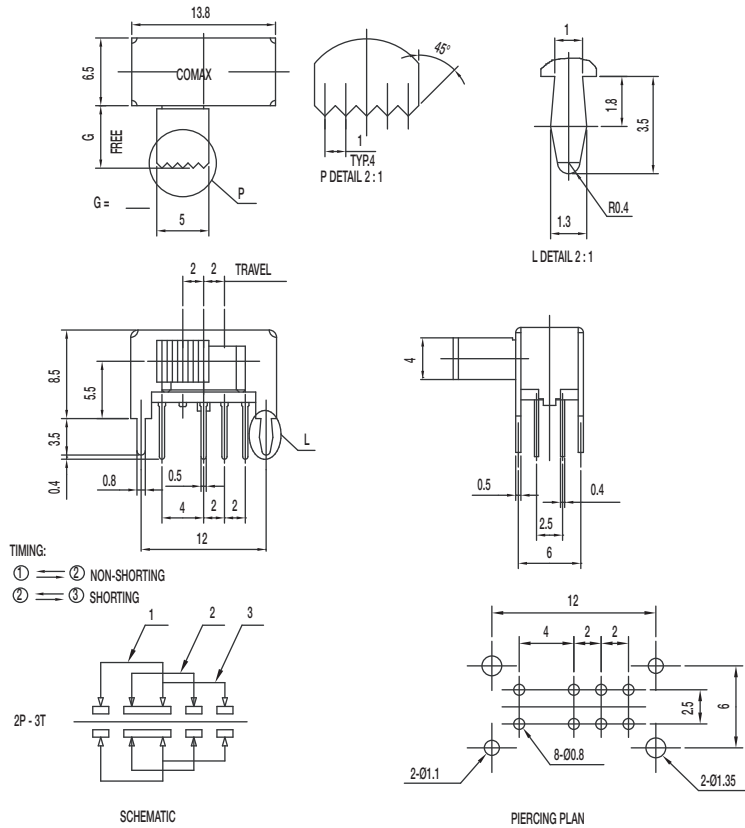

SK-24D04-G 2P4T

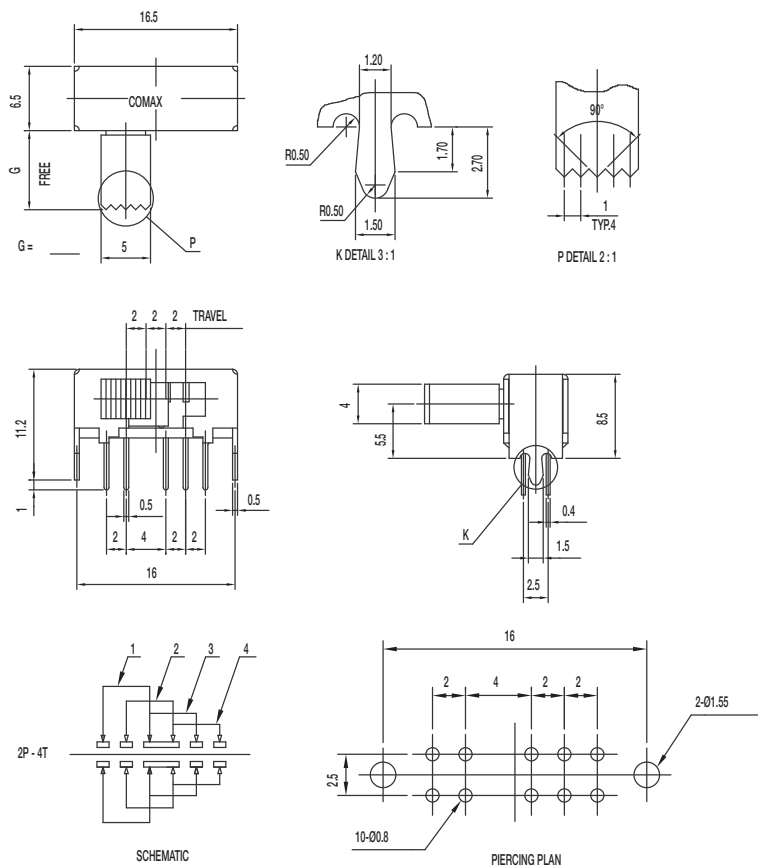

C&K

Dimensions are shown: mm
 Specifications and dimensions subject to change

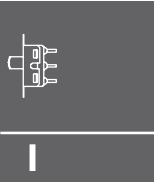

Side

SK Series Miniature Slide Switches

SK-24D24 1P3T NON-SHORTING

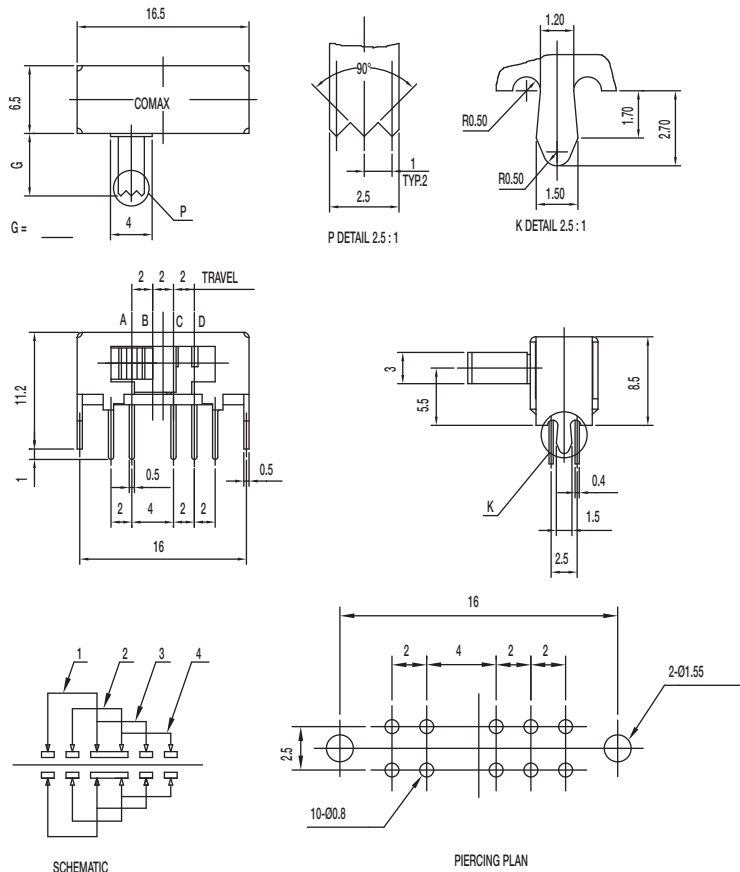

Specifications

CONTACT RATING: 0.3A @ 30 VDC
 INITIAL CONTACT RESISTANCE: 30 m ohms max.
 INSULATION RESISTANCE: 100 M ohms min.
 DIELECTRIC STRENGTH: 500 V AC (50-60 Hz) between open terminals and between the frame and terminal.
 OPERATING LIFE: 10,000 cycles with load
 OPERATING FORCE: 200 ± 100 gf (1.96 ± 0.98N)
 300 ± 150 gf (2.94 ± 1.47N)
 TRAVEL: 2 ± 0.3 mm
 OPERATING TEMPERATURE: -20°C to 70°C

Materials

KNOB: POM
 FRAME: SPCC
 CONTACT: Silver clad
 TERMINAL: Silver plated

SK-12D04-G NS 1P2T NON-SHORTING

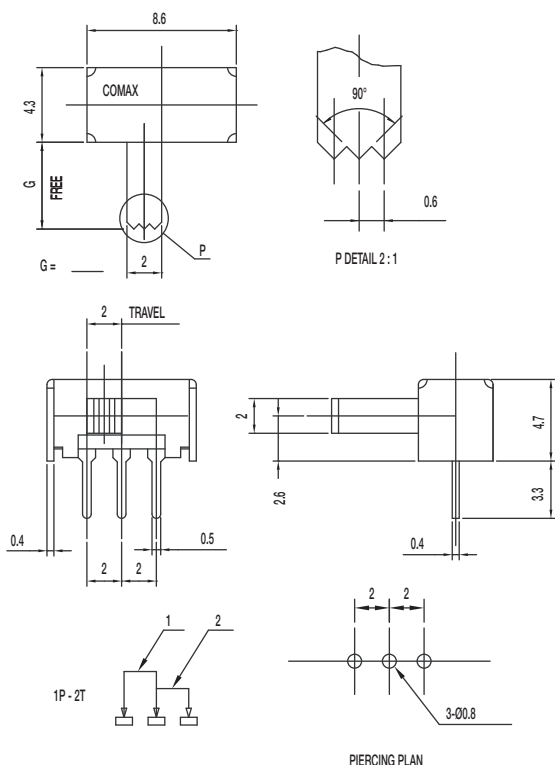

Specifications

CONTACT RATING: 0.3A @ 30 VDC
 INITIAL CONTACT RESISTANCE: 30 m ohms max.
 INSULATION RESISTANCE: 100 M ohms min.
 DIELECTRIC STRENGTH: 500 V AC (50-60 Hz) between open terminals and between the frame and terminal.
 OPERATING LIFE: 10,000 cycles with load
 OPERATING FORCE: 250 ± 100 gf (2.45 ± 0.98N)
 TRAVEL: 2 ± 0.3 mm
 OPERATING TEMPERATURE: -20°C to 70°C

Materials

KNOB: POM
 FRAME: SPCC
 CONTACT: Silver clad
 TERMINAL: Silver plated

Dimensions are shown: mm
 Specifications and dimensions subject to change

SK Series Miniature Slide Switches

SK-12D07-G NS PA 1P2T NON-SHORTING

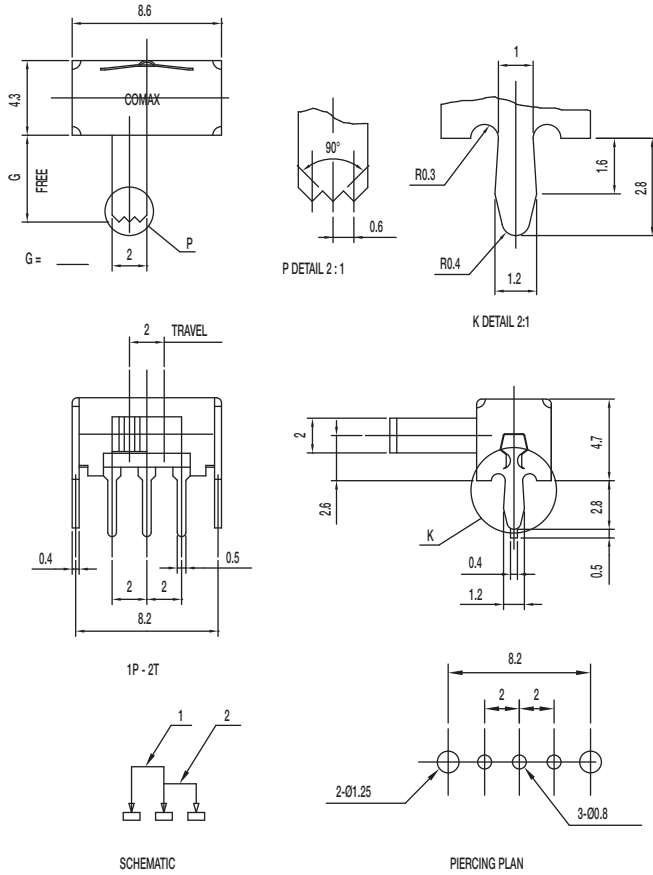

Specifications

CONTACT RATING: 0.3A @ 30 VDC
 INITIAL CONTACT RESISTANCE: 30 m ohms max.
 INSULATION RESISTANCE: 100 M ohms min.
 DIELECTRIC STRENGTH: 500 V AC (50-60 Hz) between open terminals and between the frame and terminal.
 OPERATING LIFE: 10,000 cycles with load
 OPERATING FORCE: 250 ± 100 gf (2.45 ± 0.98N)
 TRAVEL: 2 ± 0.3 mm
 OPERATING TEMPERATURE: -20°C to 70°C

Materials

KNOB: PA
 FRAME: SPCC
 CONTACT: Silver clad
 TERMINAL: Silver plated

SK-13D16-VG PA 1P3T

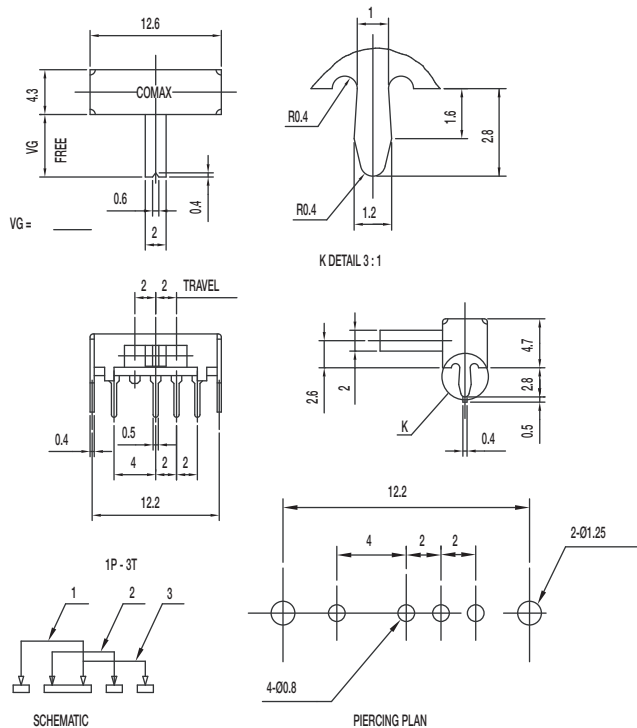

Specifications

CONTACT RATING: 0.3A @ 30 VDC
 INITIAL CONTACT RESISTANCE: 30 m ohms max.
 INSULATION RESISTANCE: 100 M ohms min.
 DIELECTRIC STRENGTH: 500 V AC (50-60 Hz) between open terminals and between the frame and terminal.
 OPERATING LIFE: 10,000 cycles with load
 OPERATING FORCE: 200 ± 100 gf (1.96 ± 0.98N)
 250 ± 100 gf (2.45 ± 0.98N)
 TRAVEL: 2 ± 0.3 mm
 OPERATING TEMPERATURE: -20°C to 70°C

Materials

KNOB: PA
 FRAME: SPCC
 CONTACT: Silver clad
 TERMINAL: Silver plated

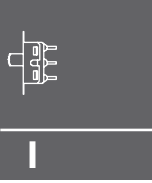

Side

SK Series Miniature Slide Switches

SK-14D01-G 1P4T

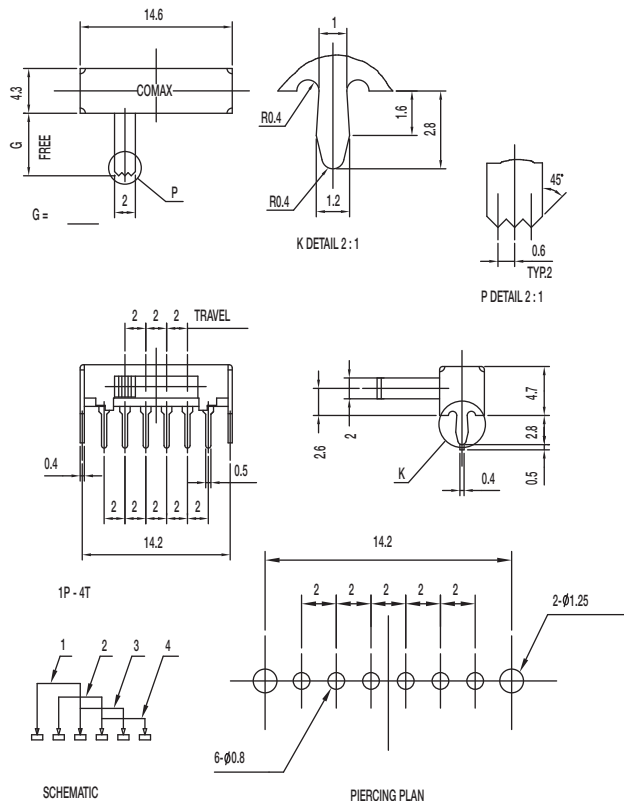

Specifications

CONTACT RATING: 0.3A @ 30 VDC
 INITIAL CONTACT RESISTANCE: 30 m ohms max.
 INSULATION RESISTANCE: 100 M ohms min.
 DIELECTRIC STRENGTH: 500 V AC (50-60 Hz) between open terminals and between the frame and terminal.
 OPERATING LIFE: 10,000 cycles with load
 OPERATING FORCE: 200 ± 100 gf (1.96 ± 0.98N)
 250 ± 100 gf (2.45 ± 0.98N)
 TRAVEL: 2 ± 0.3 mm
 OPERATING TEMPERATURE: -20°C to 70°C

Materials

KNOB: POM
 FRAME: SPCC
 CONTACT: Silver clad
 TERMINAL: Silver plated

SK-14D07-VG PA 1P4T

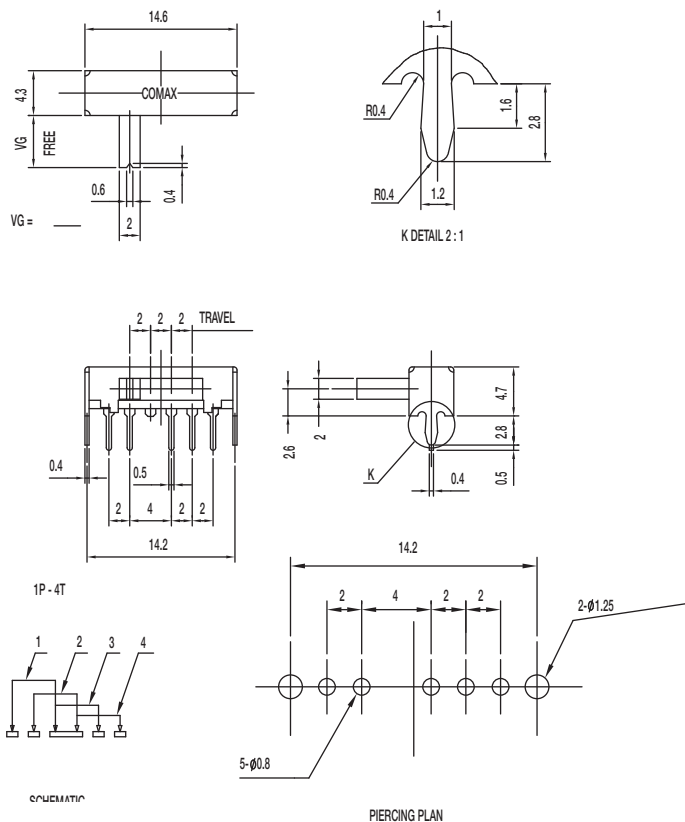

Specifications

CONTACT RATING: 0.3A @ 30 VDC
 INITIAL CONTACT RESISTANCE: 30 m ohms max.
 INSULATION RESISTANCE: 100 M ohms min.
 DIELECTRIC STRENGTH: 500 V AC (50-60 Hz) between open terminals and between the frame and terminal.
 OPERATING LIFE: 10,000 cycles with load
 OPERATING FORCE: 200 ± 100 gf (1.96 ± 0.98N)
 250 ± 100 gf (2.45 ± 0.98N)
 TRAVEL: 2 ± 0.3 mm
 OPERATING TEMPERATURE: -20°C to 70°C

Materials

KNOB: PA (UL94-V0)
 FRAME: SPCC
 CONTACT: Silver clad
 TERMINAL: Silver plated

Dimensions are shown: mm
 Specifications and dimensions subject to change

Slide

SK Series Miniature Slide Switches

SK-22D07-G NS PA DPDT NON-SHORTING

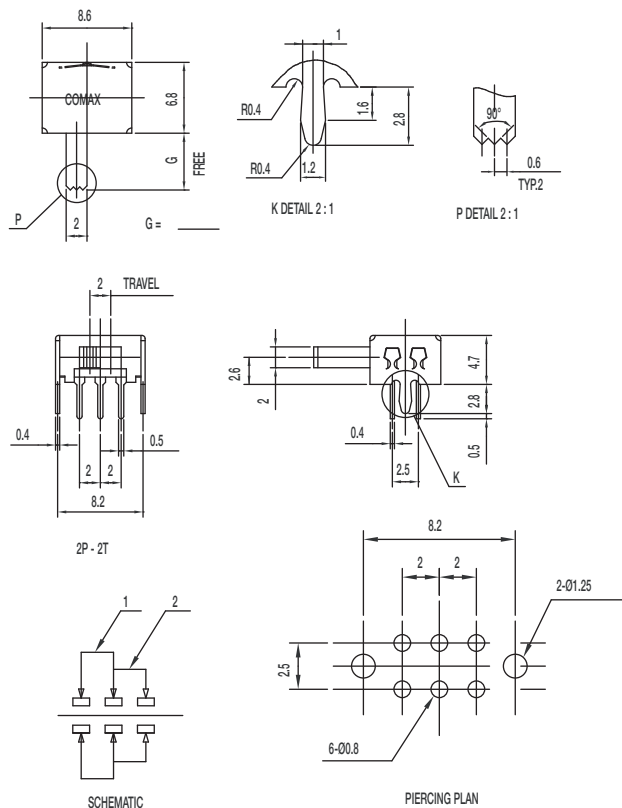

Specifications

CONTACT RATING: 0.3A @ 30 VDC
 INITIAL CONTACT RESISTANCE: 30 m ohms max.
 INSULATION RESISTANCE: 100 M ohms min.
 DIELECTRIC STRENGTH: 500 V AC (50-60 Hz) between open terminals and between the frame and terminal.
 OPERATING LIFE: 10,000 cycles with load
 OPERATING FORCE: 250 ± 100 gf (2.45 ± 0.98N)
 TRAVEL: 2 ± 0.3 mm
 OPERATING TEMPERATURE: -20°C to 70°C

Materials

KNOB: PA (UL94V-0)
 FRAME: SPCC
 CONTACT: Silver clad
 TERMINAL: Silver plated

SK-22H07-VG DPDT NON-SHORTING

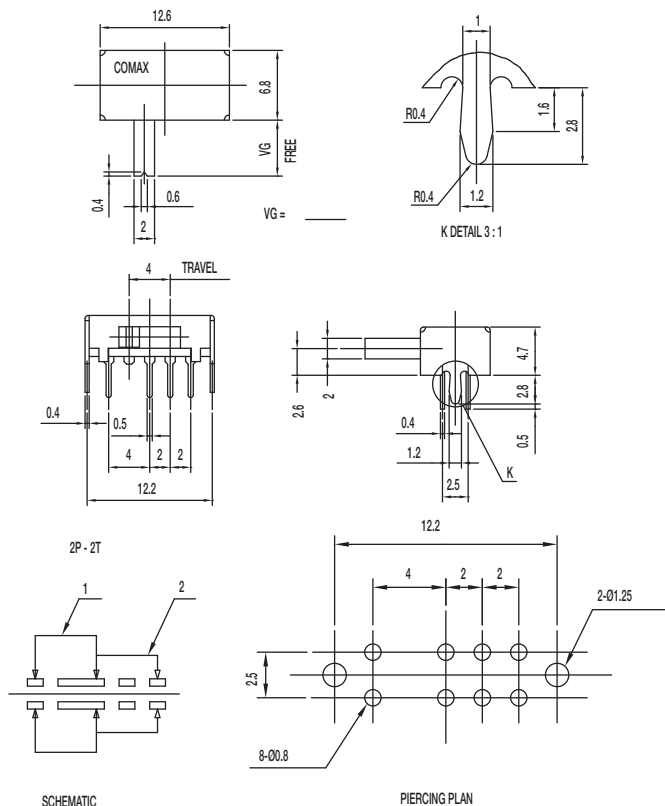

Specifications

CONTACT RATING: 0.3A @ 30 VDC
 INITIAL CONTACT RESISTANCE: 30 m ohms max.
 INSULATION RESISTANCE: 100 M ohms min.
 DIELECTRIC STRENGTH: 500 V AC (50-60 Hz) between open terminals and between the frame and terminal.
 OPERATING LIFE: 10,000 cycles with load
 OPERATING FORCE: 200 ± 100 gf (1.96 ± 0.98N)
 TRAVEL: 4 ± 0.3 mm
 OPERATING TEMPERATURE: -20°C to 70°C

Materials

KNOB: POM
 FRAME: SPCC
 CONTACT: Silver clad
 TERMINAL: Silver plated



Dimensions are shown: mm
 Specifications and dimensions subject to change

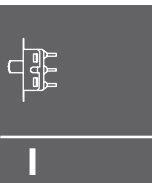

Slide

SK Series Miniature Slide Switches

SK-23D09-G 2P3T

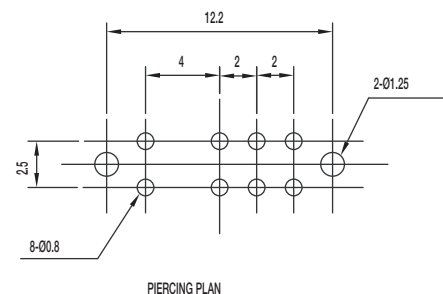
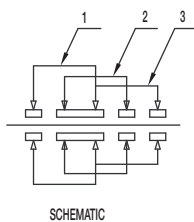
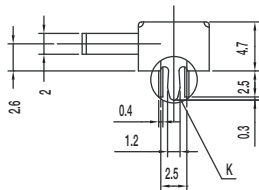
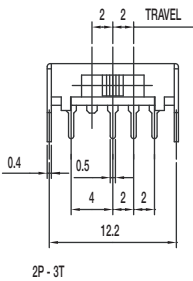
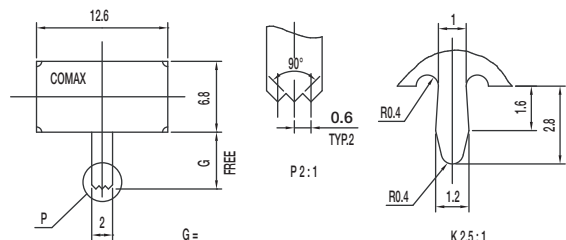

Specifications

CONTACT RATING: 0.3A @ 30 VDC
 INITIAL CONTACT RESISTANCE: 30 m ohms max.
 INSULATION RESISTANCE: 100 M ohms min.
 DIELECTRIC STRENGTH: 500 V AC (50-60 Hz) between open terminals and between the frame and terminal.
 OPERATING LIFE: 10,000 cycles with load
 OPERATING FORCE: 200 ± 100 gf (1.96 ± 0.98N)
 250 ± 100 gf (2.45 ± 0.98N)
 TRAVEL: 2 ± 0.3 mm
 OPERATING TEMPERATURE: -20°C to 70°C

Materials

KNOB: POM
 FRAME: SPCC
 CONTACT: Silver clad
 TERMINAL: Silver plated

SK-24D02-G 2P4T

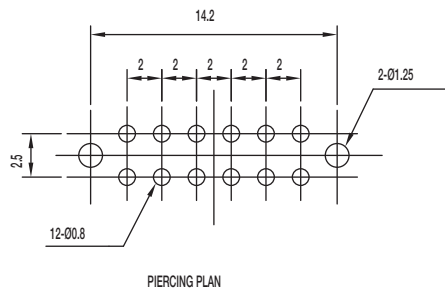
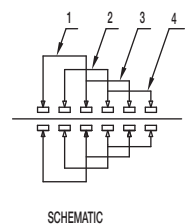
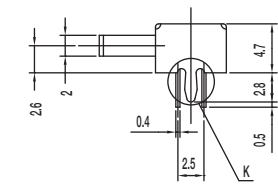
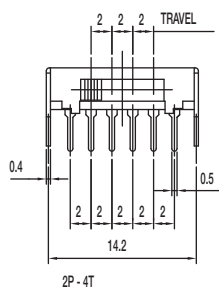
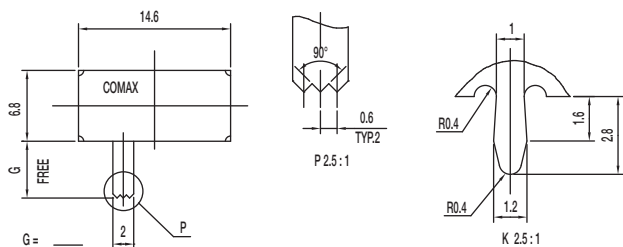

Specifications

CONTACT RATING: 0.3A @ 30 VDC
 INITIAL CONTACT RESISTANCE: 30 m ohms max.
 INSULATION RESISTANCE: 100 M ohms min.
 DIELECTRIC STRENGTH: 500 V AC (50-60 Hz) between open terminals and between the frame and terminal.
 OPERATING LIFE: 10,000 cycles with load
 OPERATING FORCE: 250 ± 100 gf (2.45 ± 0.98N)
 TRAVEL: 2 ± 0.3 mm
 OPERATING TEMPERATURE: -20°C to 70°C

Materials

KNOB: POM
 FRAME: SPCC
 CONTACT: Silver clad
 TERMINAL: Silver plated



Dimensions are shown: mm
 Specifications and dimensions subject to change

SK Series Miniature Slide Switches

SK-24D07-VG NS (S) 2P4T NON-SHORTING

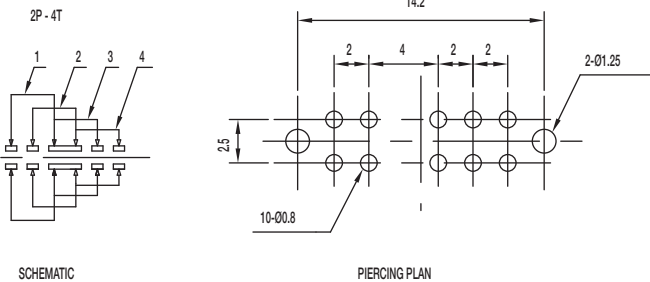
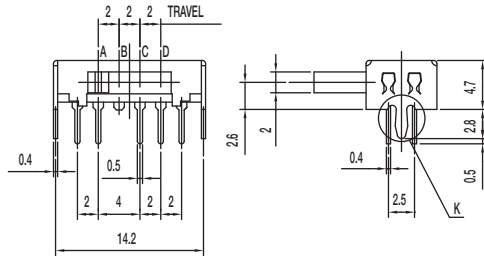
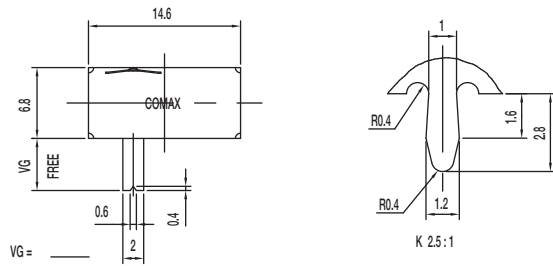

SK-42D07-G NS 4P2T NON-SHORTING

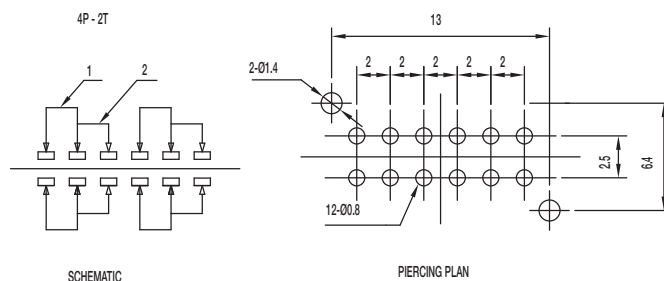
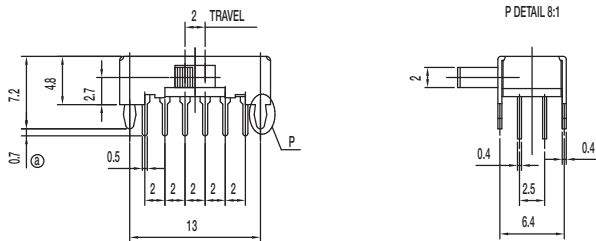
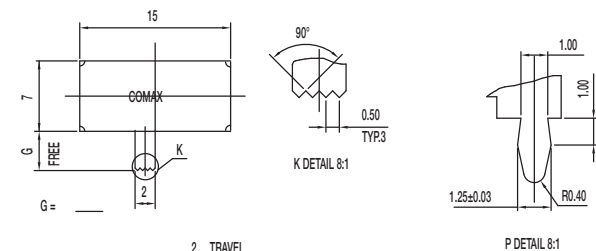

Specifications

CONTACT RATING: 0.3A @ 30 VDC
 INITIAL CONTACT RESISTANCE: 30 m ohms max.
 INSULATION RESISTANCE: 100 M ohms min.
 DIELECTRIC STRENGTH: 500 V AC (50-60 Hz) between open terminals and between the frame and terminal.
 OPERATING LIFE: 10,000 cycles with load
 OPERATING FORCE: 350 ± 150 gf (3.43 ± 1.47N)
 TRAVEL: 2 ± 0.3 mm
 OPERATING TEMPERATURE: -20°C to 70°C

Materials

KNOB: POM
 FRAME: SPCC
 CONTACT: Silver clad
 TERMINAL: Silver plated

Specifications

CONTACT RATING: 0.3A @ 30 VDC
 INITIAL CONTACT RESISTANCE: 30 m ohms max.
 INSULATION RESISTANCE: 100 M ohms min.
 DIELECTRIC STRENGTH: 500 V AC (50-60 Hz) between open terminals and between the frame and terminal.
 OPERATING LIFE: 10,000 cycles with load
 OPERATING FORCE: 250 ± 100 gf (2.45 ± 0.98N)
 TRAVEL: 2 ± 0.3 mm
 OPERATING TEMPERATURE: -20°C to 70°C

Materials

KNOB: POM
 FRAME: SPCC
 CONTACT: Silver clad
 TERMINAL: Silver plated



Dimensions are shown: mm
 Specifications and dimensions subject to change

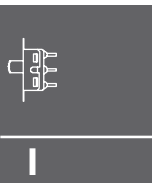

Slide

SK Series Miniature Slide Switches

SK-12D26-G 6.5 NS GY 1P2T NON-SHORTING

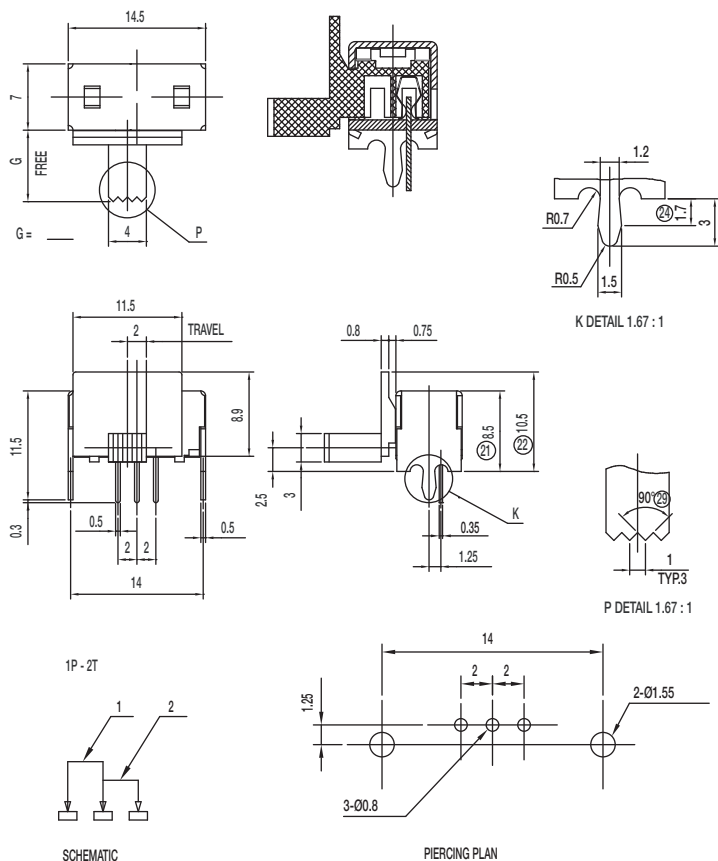

Specifications

CONTACT RATING: 0.3A @ 30 VDC
 INITIAL CONTACT RESISTANCE: 20 m ohms max.
 INSULATION RESISTANCE: 500 M ohms min.
 DIELECTRIC STRENGTH: 500 V AC (50-60 Hz) between open terminals and between the frame and terminal.
 OPERATING LIFE: 10,000 cycles with load
 OPERATING FORCE: 250 ± 100 gf (2.45 ± 0.98N)
 TRAVEL: 2 ± 0.3 mm
 OPERATING TEMPERATURE: -20°C to 70°C

Materials

KNOB: POM
 FRAME: SPCC
 CONTACT: Silver clad
 TERMINAL: Silver plated

SK-12D37-G NS 1P2T NON-SHORTING

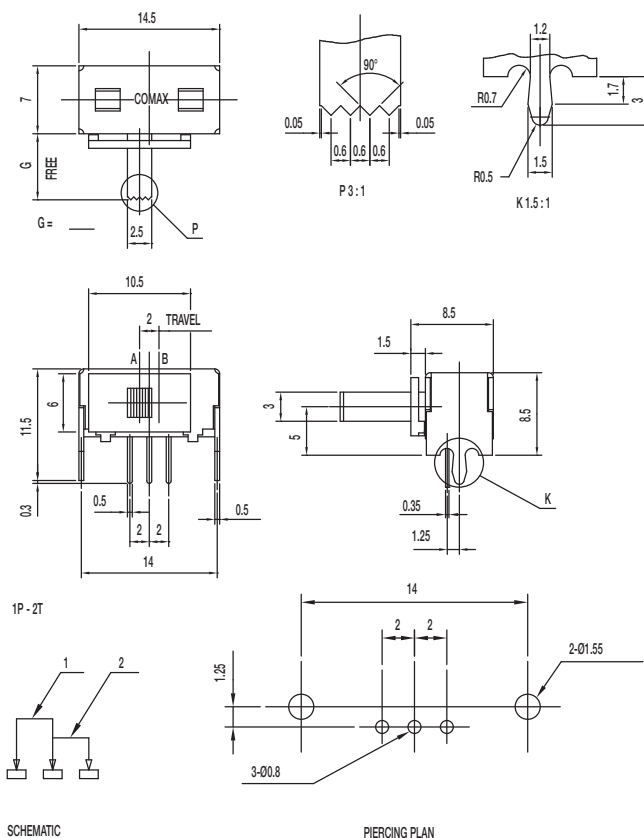

Specifications

CONTACT RATING: 0.3A @ 30 VDC
 INITIAL CONTACT RESISTANCE: 30 m ohms max.
 INSULATION RESISTANCE: 100 M ohms min.
 DIELECTRIC STRENGTH: 500 V AC (50-60 Hz) between open terminals and between the frame and terminal.
 OPERATING LIFE: 10,000 cycles with load
 OPERATING FORCE: 200 ± 100 gf (1.96 ± 0.98N)
 TRAVEL: 2 ± 0.3 mm
 OPERATING TEMPERATURE: -20°C to 70°C

Materials

KNOB: POM
 FRAME: SPCC
 CONTACT: Silver clad
 TERMINAL: Silver plated



Dimensions are shown: mm
 Specifications and dimensions subject to change

SK Series Miniature Slide Switches

SK-13D37-G NS 1P3T NON-SHORTING

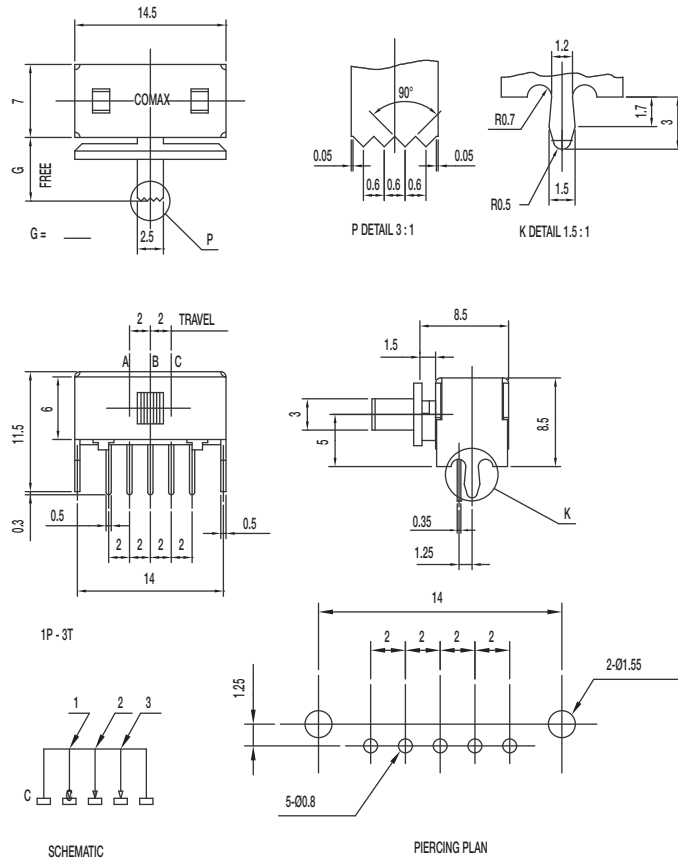

Specifications

CONTACT RATING: 0.3A @ 30 VDC
 INITIAL CONTACT RESISTANCE: 30 m ohms max.
 INSULATION RESISTANCE: 100 M ohms min.
 DIELECTRIC STRENGTH: 500 V AC (50-60 Hz) between open terminals and between the frame and terminal.
 OPERATING LIFE: 10,000 cycles with load
 OPERATING FORCE: 200 ± 100 gf (1.96 ± 0.98N)
 300 ± 150 gf (2.94 ± 1.47N)
 TRAVEL: 2 ± 0.3 mm
 OPERATING TEMPERATURE: -20°C to 70°C

Materials

KNOB: POM
 FRAME: SPCC
 CONTACT: Silver clad
 TERMINAL: Silver plated

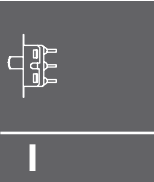

Slide

SK-22D27-G NS DPDT NON-SHORTING

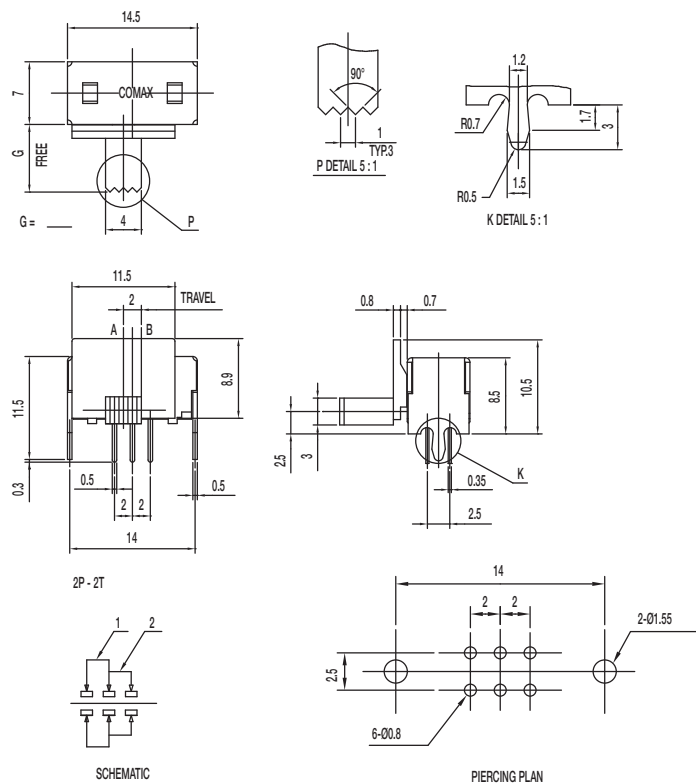

Specifications

CONTACT RATING: 0.3A @ 30 VDC
 INITIAL CONTACT RESISTANCE: 30 m ohms max.
 INSULATION RESISTANCE: 100 M ohms min.
 DIELECTRIC STRENGTH: 500 V AC (50-60 Hz) between open terminals and between the frame and terminal.
 OPERATING LIFE: 10,000 cycles with load
 OPERATING FORCE: 250 ± 100 gf (2.45 ± 0.98N)
 TRAVEL: 2 ± 0.3 mm
 OPERATING TEMPERATURE: -20°C to 70°C

Materials

KNOB: POM
 FRAME: SPCC
 CONTACT: Silver clad
 TERMINAL: Silver plated



Dimensions are shown: mm
 Specifications and dimensions subject to change

SK Series Miniature Slide Switches

SK-22D37-G NS DPDT NON-SHORTING

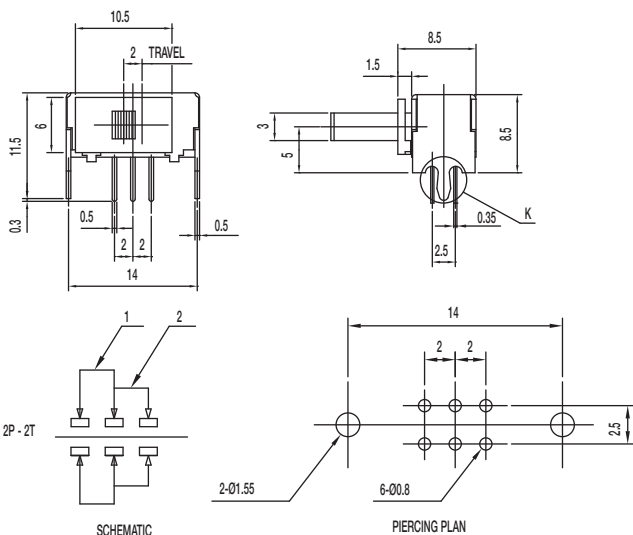
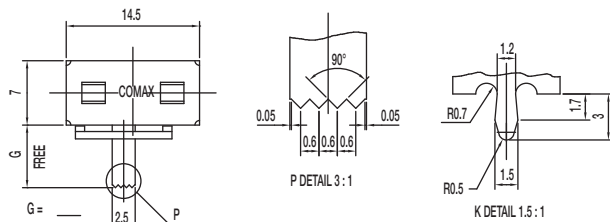

Specifications

CONTACT RATING: 0.3A @ 30 VDC
 INITIAL CONTACT RESISTANCE: 30 m ohms max.
 INSULATION RESISTANCE: 100 M ohms min.
 DIELECTRIC STRENGTH: 500 V AC (50-60 Hz) between open terminals and between the frame and terminal.
 OPERATING LIFE: 10,000 cycles with load
 OPERATING FORCE: 200 ± 100 gf (1.96 ± 0.98N)
 TRAVEL: 2 ± 0.3 mm
 OPERATING TEMPERATURE: -20°C to 70°C

Materials

KNOB: POM
 FRAME: SPCC
 CONTACT: Silver clad
 TERMINAL: Silver plated

SK-23D37-G NS 2P3T NON-SHORTING

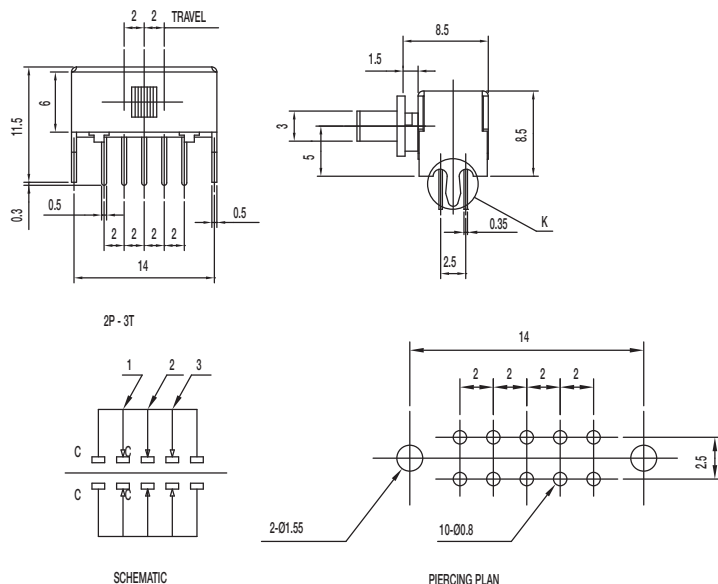
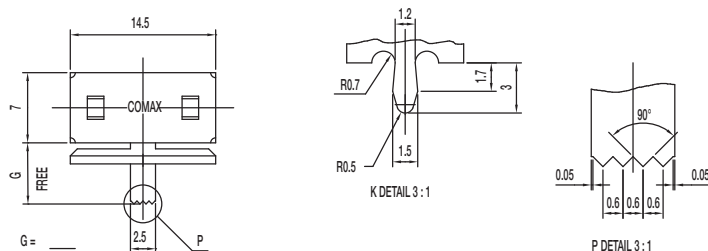

Specifications

CONTACT RATING: 0.3A @ 30 VDC
 INITIAL CONTACT RESISTANCE: 30 m ohms max.
 INSULATION RESISTANCE: 100 M ohms min.
 DIELECTRIC STRENGTH: 500 V AC (50-60 Hz) between open terminals and between the frame and terminal.
 OPERATING LIFE: 10,000 cycles with load
 OPERATING FORCE: 200 ± 100 gf (1.96 ± 0.98N)
 300 ± 150 gf (2.94 ± 1.47N)
 TRAVEL: 2 ± 0.3 mm
 OPERATING TEMPERATURE: -20°C to 70°C

Materials

KNOB: POM
 FRAME: SPCC
 CONTACT: Silver clad
 TERMINAL: Silver plated



Dimensions are shown: mm
 Specifications and dimensions subject to change

SK Series Miniature Slide Switches

SK-22H01-G RP DPDT NON-SHORTING

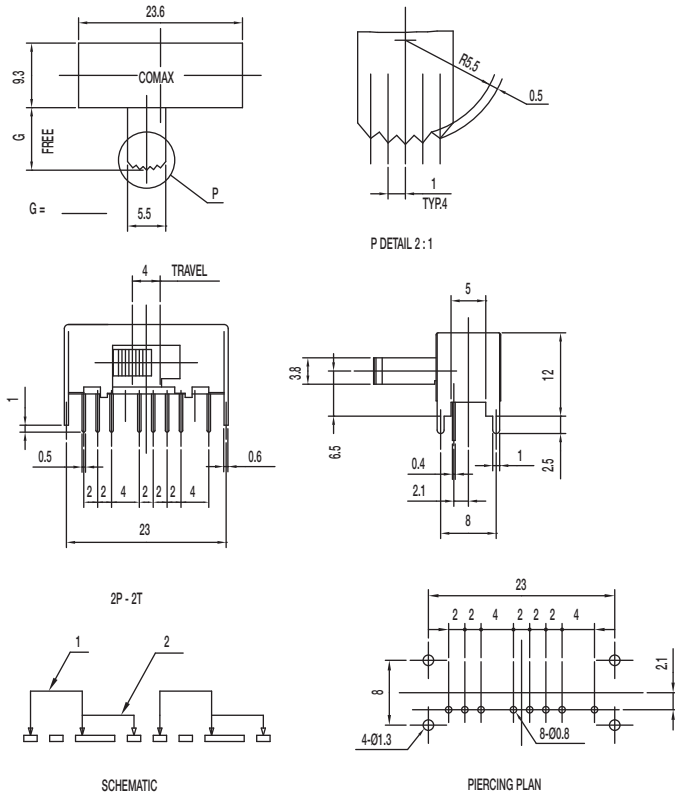

Specifications

CONTACT RATING: 0.3A @ 30 VDC
 INITIAL CONTACT RESISTANCE: 30 m ohms max.
 INSULATION RESISTANCE: 100 M ohms min.
 DIELECTRIC STRENGTH: 500 V AC (50-60 Hz) between open terminals and between the frame and terminal.
 OPERATING LIFE: 10,000 cycles with load
 OPERATING FORCE: 250 ± 100 gf (2.45 ± 0.98N)
 TRAVEL: 4 ± 0.3 mm
 OPERATING TEMPERATURE: -20°C to 70°C

Materials

KNOB: POM
 FRAME: SPCC
 CONTACT: Silver clad
 TERMINAL: Silver plated

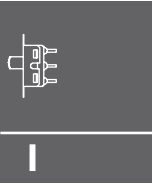

Side

SK-22H17-G DPDT NON-SHORTING

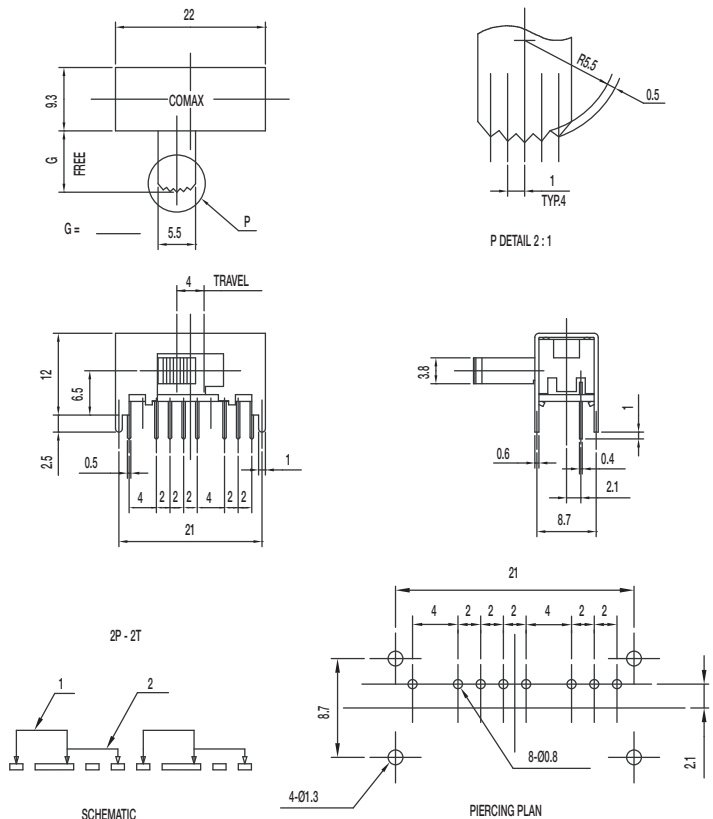

Specifications

CONTACT RATING: 0.3A @ 30 VDC
 INITIAL CONTACT RESISTANCE: 30 m ohms max.
 INSULATION RESISTANCE: 100 M ohms min.
 DIELECTRIC STRENGTH: 500 V AC (50-60 Hz) between open terminals and between the frame and terminal.
 OPERATING LIFE: 10,000 cycles with load
 OPERATING FORCE: 250 ± 100 gf (2.45 ± 0.98N)
 TRAVEL: 4 ± 0.3 mm
 OPERATING TEMPERATURE: -20°C to 70°C

Materials

KNOB: POM
 FRAME: SPCC
 CONTACT: Silver clad
 TERMINAL: Silver plated



Dimensions are shown: mm
 Specifications and dimensions subject to change

SK Series Miniature Slide Switches

SK-23D10-G 2P3T

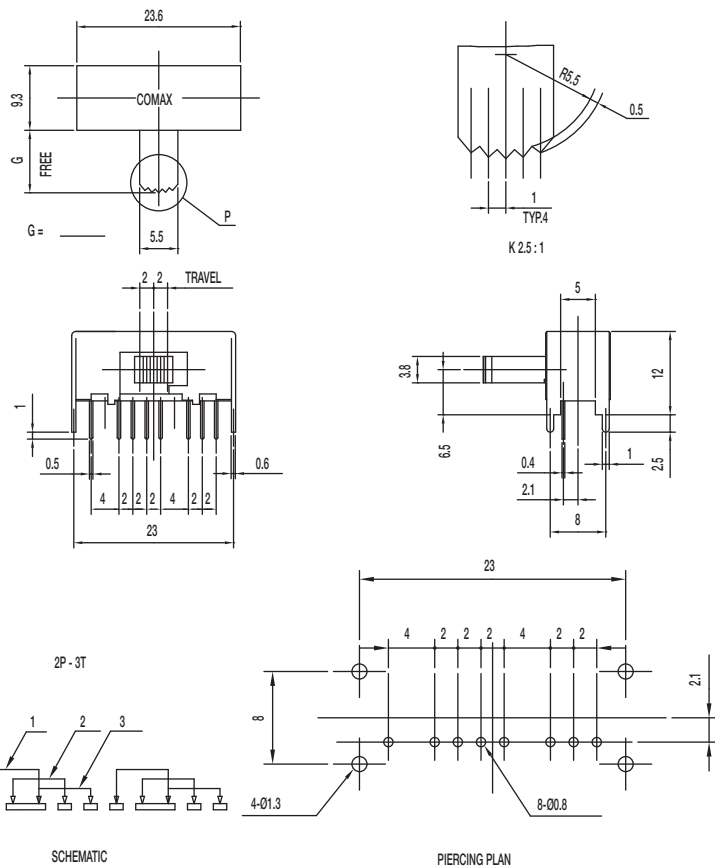

Specifications

CONTACT RATING: 0.3A @ 30 VDC
 INITIAL CONTACT RESISTANCE: 30 m ohms max.
 INSULATION RESISTANCE: 100 M ohms min.
 DIELECTRIC STRENGTH: 500 V AC (50-60 Hz) between open terminals and between the frame and terminal.
 OPERATING LIFE: 10,000 cycles with load
 OPERATING FORCE: 200 ± 100 gf (1.96 ± 0.98N)
 350 ± 150 gf (3.43 ± 1.47N)
 TRAVEL: 2 ± 0.3 mm
 OPERATING TEMPERATURE: -20°C to 70°C

Materials

KNOB: POM
 FRAME: SPCC
 CONTACT: Silver clad
 TERMINAL: Silver plated

SK-23D13-G 2P3T

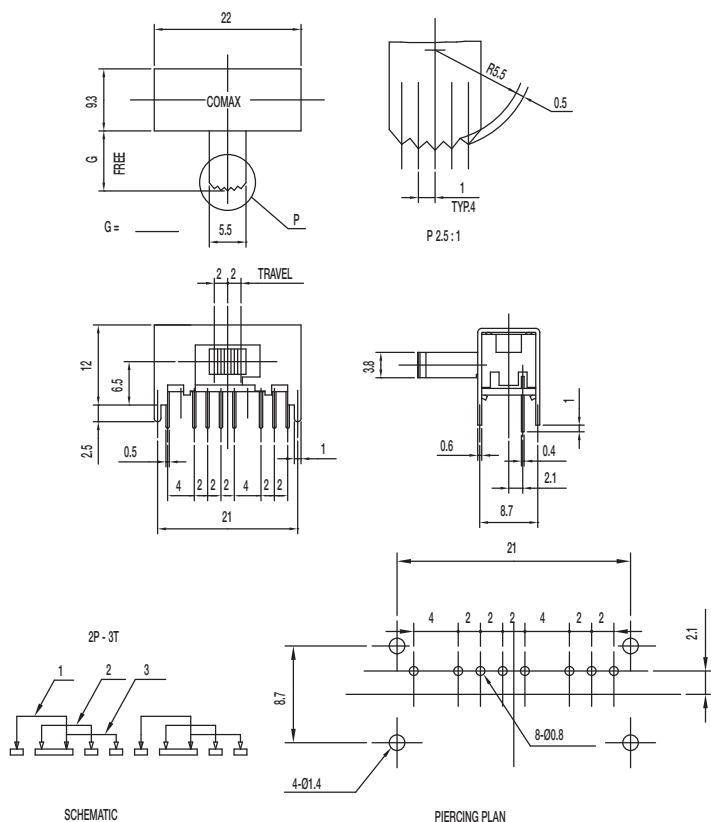

Specifications

CONTACT RATING: 0.3A @ 30 VDC
 INITIAL CONTACT RESISTANCE: 30 m ohms max.
 INSULATION RESISTANCE: 100 M ohms min.
 DIELECTRIC STRENGTH: 500 V AC (50-60 Hz) between open terminals and between the frame and terminal.
 OPERATING LIFE: 10,000 cycles with load
 OPERATING FORCE: 200 ± 100 gf (1.96 ± 0.98N)
 300 ± 150 gf (2.94 ± 1.47N)
 TRAVEL: 2 ± 0.3 mm
 OPERATING TEMPERATURE: -20°C to 70°C

Materials

KNOB: POM
 FRAME: SPCC
 CONTACT: Silver clad
 TERMINAL: Silver plated

Dimensions are shown: mm
 Specifications and dimensions subject to change

SK Series Miniature Slide Switches

SK-42H01-G 4P2T NON-SHORTING

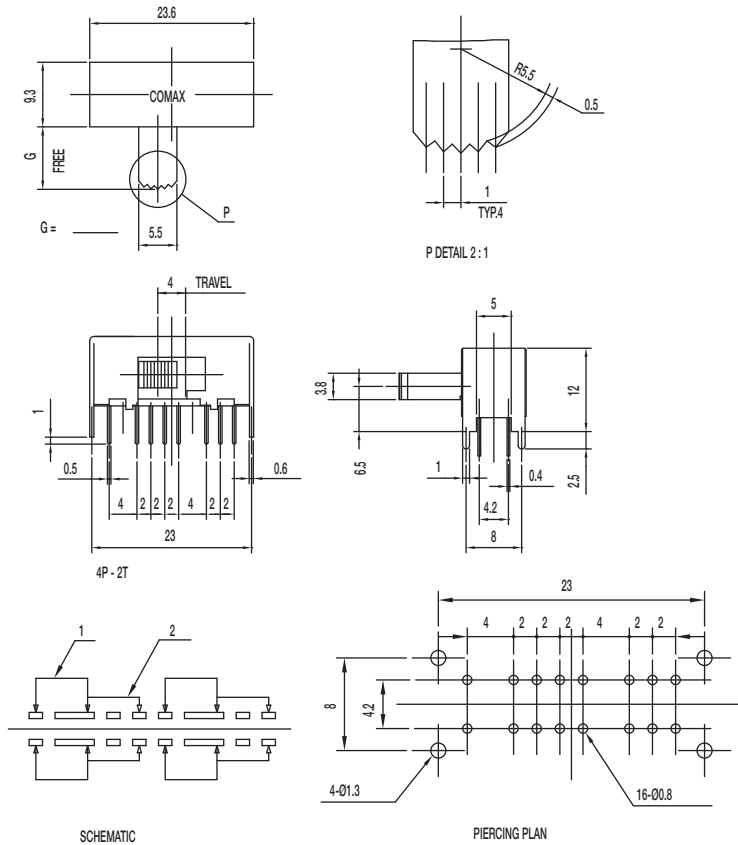

Specifications

CONTACT RATING: 0.3A @ 30 VDC
 INITIAL CONTACT RESISTANCE: 30 m ohms max.
 INSULATION RESISTANCE: 100 M ohms min.
 DIELECTRIC STRENGTH: 500 V AC (50-60 Hz) between open terminals and between the frame and terminal.
 OPERATING LIFE: 10,000 cycles with load
 OPERATING FORCE: 250 ± 100 gf (2.45 ± 0.98 N)
 TRAVEL: 4 ± 0.3 mm
 OPERATING TEMPERATURE: -20°C to 70°C

Materials

KNOB: POM
 FRAME: SPCC
 CONTACT: Silver clad
 TERMINAL: Silver plated

SK-42H02-G 4P2T NON-SHORTING

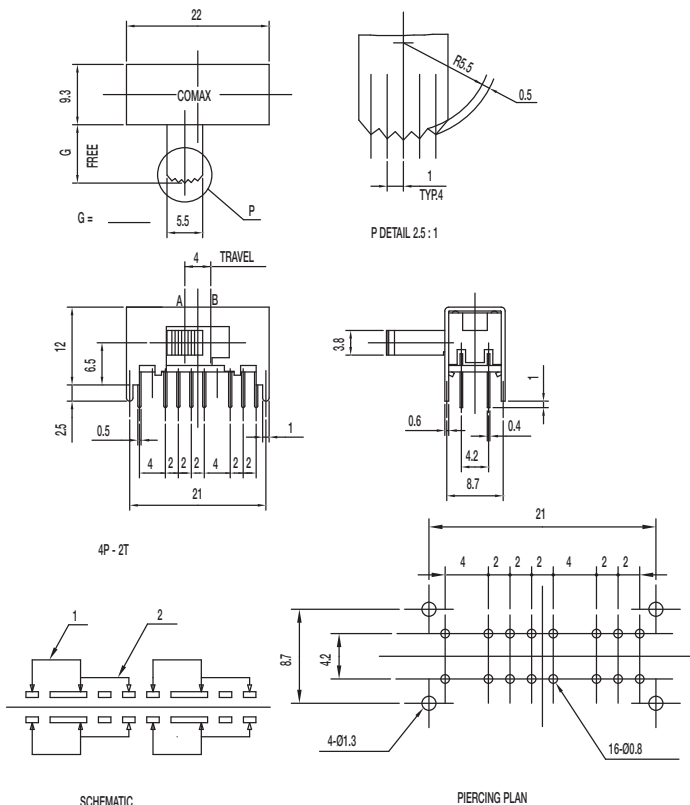

Specifications

CONTACT RATING: 0.3A @ 30 VDC
 INITIAL CONTACT RESISTANCE: 30 m ohms max.
 INSULATION RESISTANCE: 100 M ohms min.
 DIELECTRIC STRENGTH: 500 V AC (50-60 Hz) between open terminals and between the frame and terminal.
 OPERATING LIFE: 10,000 cycles with load
 OPERATING FORCE: 250 ± 100 gf (2.45 ± 0.98 N)
 TRAVEL: 4 ± 0.3 mm
 OPERATING TEMPERATURE: -20°C to 70°C

Materials

KNOB: POM
 FRAME: SPCC
 CONTACT: Silver clad
 TERMINAL: Silver plated



Dimensions are shown: mm
 Specifications and dimensions subject to change

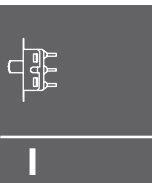

Side

SK Series Miniature Slide Switches

SK-42H05 4P2T NON-SHORTING

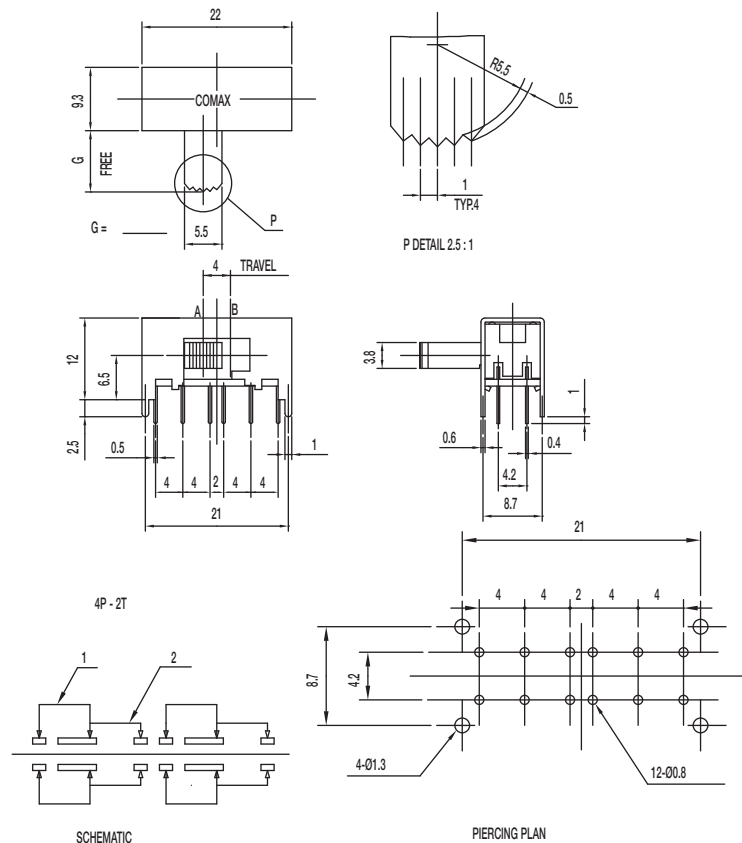

Specifications

CONTACT RATING: 0.3A @ 30 VDC
 INITIAL CONTACT RESISTANCE: 30 m ohms max.
 INSULATION RESISTANCE: 100 M ohms min.
 DIELECTRIC STRENGTH: 500 V AC (50-60 Hz) between open terminals and between the frame and terminal.
 OPERATING LIFE: 10,000 cycles with load
 OPERATING FORCE: 250 ± 100 gf (2.45 ± 0.98 N)
 TRAVEL: 4 ± 0.3 mm
 OPERATING TEMPERATURE: -20°C to 70°C

Materials

KNOB: POM
 FRAME: SPCC
 CONTACT: Silver clad
 TERMINAL: Silver plated

SK-42H06-G 4P2T NON-SHORTING

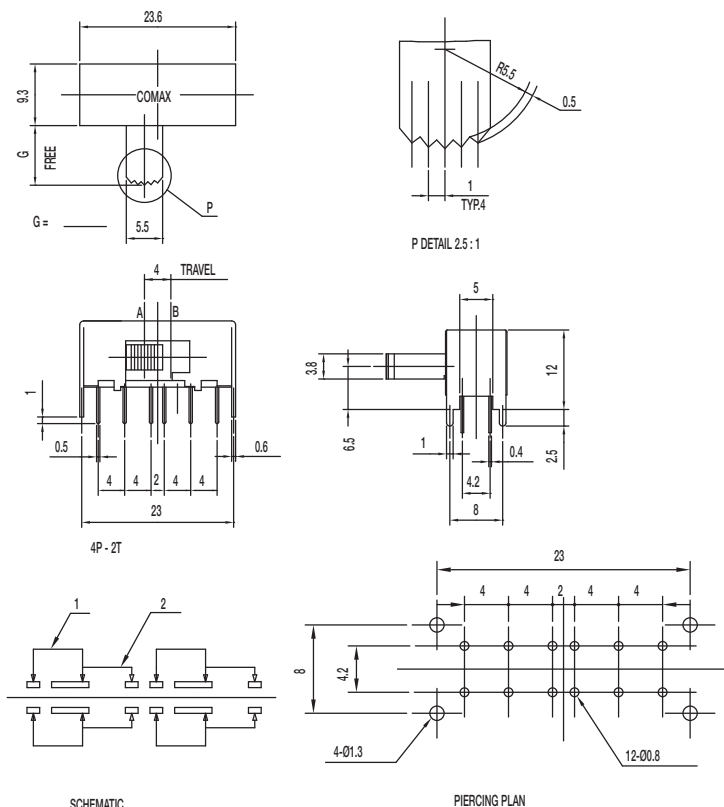

Specifications

CONTACT RATING: 0.3A @ 30 VDC
 INITIAL CONTACT RESISTANCE: 30 m ohms max.
 INSULATION RESISTANCE: 100 M ohms min.
 DIELECTRIC STRENGTH: 500 V AC (50-60 Hz) between open terminals and between the frame and terminal.
 OPERATING LIFE: 10,000 cycles with load
 OPERATING FORCE: 250 ± 100 gf (2.45 ± 0.98 N)
 350 ± 150 gf (3.43 ± 1.47 N)
 TRAVEL: 4 ± 0.3 mm
 OPERATING TEMPERATURE: -20°C to 70°C

Materials

KNOB: POM
 FRAME: SPCC
 CONTACT: Silver clad
 TERMINAL: Silver plated



Dimensions are shown: mm
 Specifications and dimensions subject to change

SK Series Miniature Slide Switches

SK-43D01-G 4P3T

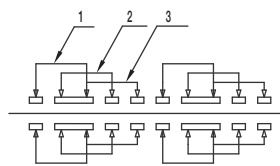
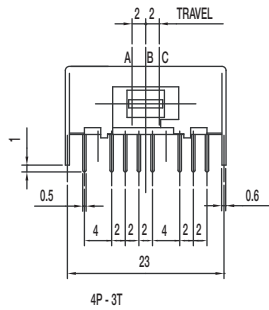
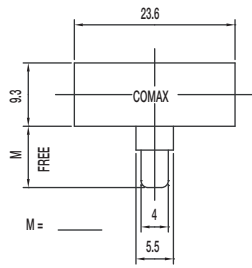

SCHEMATIC

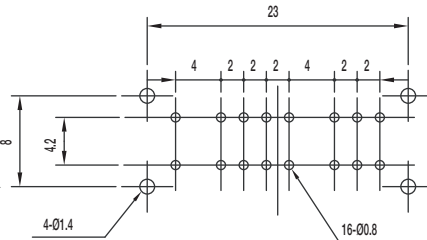
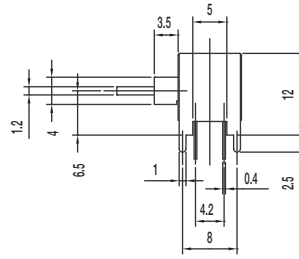

PIERCING PLAN

Specifications

CONTACT RATING: 0.3A @ 30 VDC
 INITIAL CONTACT RESISTANCE: 30 m ohms max.
 INSULATION RESISTANCE: 100 M ohms min.
 DIELECTRIC STRENGTH: 500 V AC (50-60 Hz) between open terminals and between the frame and terminal.
 OPERATING LIFE: 10,000 cycles with load
 OPERATING FORCE: 250 ± 100 gf (2.45 ± 0.98N)
 350 ± 150 gf (3.43 ± 1.47N)
 TRAVEL: 2 ± 0.3 mm
 OPERATING TEMPERATURE: -20°C to 70°C

Materials

KNOB: POM
 FRAME: SPCC
 CONTACT: Silver clad
 TERMINAL: Silver plated

SK-43D03-G 4P3T SHORTING

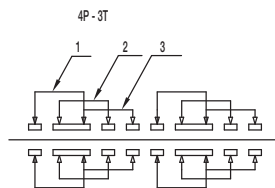
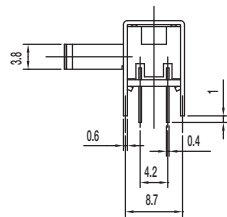
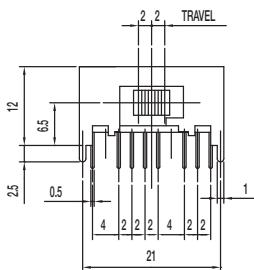
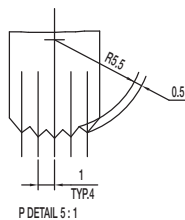
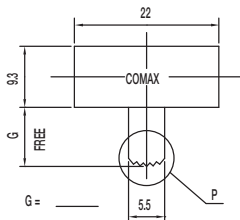

SCHEMATIC

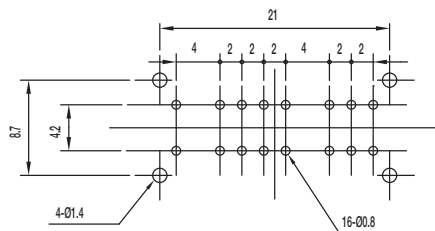

PIERCING PLAN

Specifications

CONTACT RATING: 0.3A @ 30 VDC
 INITIAL CONTACT RESISTANCE: 30 m ohms max.
 INSULATION RESISTANCE: 100 M ohms min.
 DIELECTRIC STRENGTH: 500 V AC (50-60 Hz) between open terminals and between the frame and terminal.
 OPERATING LIFE: 10,000 cycles with load
 OPERATING FORCE: 250 ± 100 gf (2.45 ± 0.98N)
 350 ± 150 gf (3.43 ± 1.47N)
 TRAVEL: 2 ± 0.3 mm
 OPERATING TEMPERATURE: -20°C to 70°C

Materials

KNOB: POM
 FRAME: SPCC
 CONTACT: Silver clad
 TERMINAL: Silver plated



Dimensions are shown: mm
 Specifications and dimensions subject to change

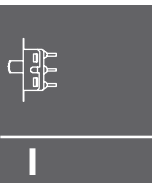

Side

SK Series Miniature Slide Switches

SK-44D01-G 4P4T SHORTING

Specifications

CONTACT RATING: 0.3A @ 30 VDC

INITIAL CONTACT RESISTANCE: 30 m ohms max.

INSULATION RESISTANCE: 100 M ohms min.

DIELECTRIC STRENGTH: 500 V AC (50-60 Hz) between open terminals and between the frame and terminal.

OPERATING LIFE: 10,000 cycles with load

OPERATING FORCE: 150 ± 50 gf (1.47 ± 0.49N)

200 ± 100 gf (1.96 ± 0.98N); 250 ± 100 gf (2.45 ± 0.98N)

TRAVEL: 2 ± 0.3 mm

OPERATING TEMPERATURE: -20°C to 70°C



Slide Materials

KNOB: POM

FRAME: SPCC

CONTACT: Silver clad

TERMINAL: Silver plated

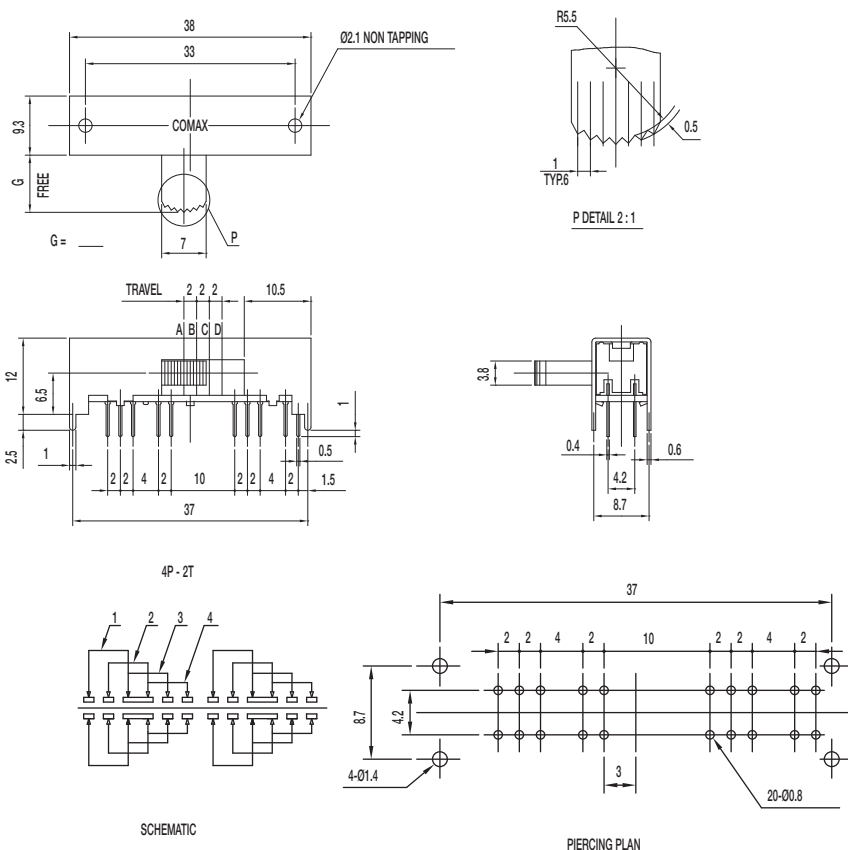

Dimensions are shown: mm
Specifications and dimensions subject to change

SS Series Miniature Slide Switches

Features/Benefits

- Broad range of products
- Various circuit design, SPDT, 4P3T, vertical, right angle
- Compact miniature slide switch
- Shorting or non-shorting
- Custom design available

Typical Applications

- Consumer electronics
- Computer peripherals
- Telecommunication
- Audio & visual equipment
- Medical
- Automotive

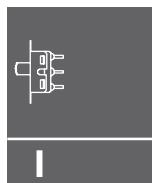
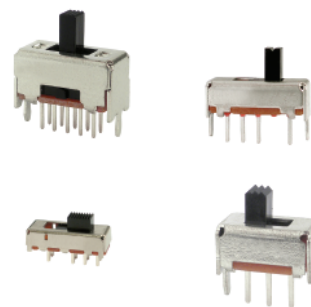

Slide

SS-12D1305-G 2 1P2T NON-SHORTING

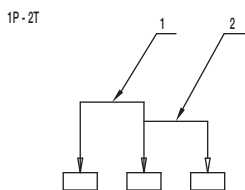
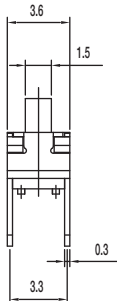
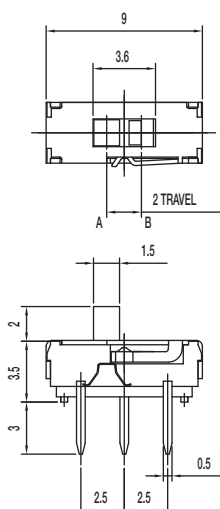

SCHEMATIC

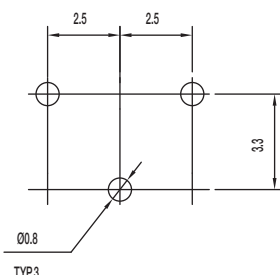

PIERCING PLAN

Specifications

- CONTACT RATING: 0.3A @ 6 VDC
- INITIAL CONTACT RESISTANCE: 70 m ohms max.
- INSULATION RESISTANCE: 100 M ohms min.
- DIELECTRIC STRENGTH: 500 V AC (50-60 Hz) between open terminals and between the frame and terminal.
- OPERATING LIFE: 10,000 cycles with load
- OPERATING FORCE: 200 ± 100 gf (1.96 ± 0.98N)
- TRAVEL: 2 ± 0.3 mm
- OPERATING TEMPERATURE: -20°C to 70°C

Materials

- KNOB: PA
- COVER: SUS
- HOUSING: PA
- CONTACT: Silver clad
- TERMINAL: Silver plated

SS Series Miniature Slide Switches

SS-12D1505-G 1P2T NON-SHORTING

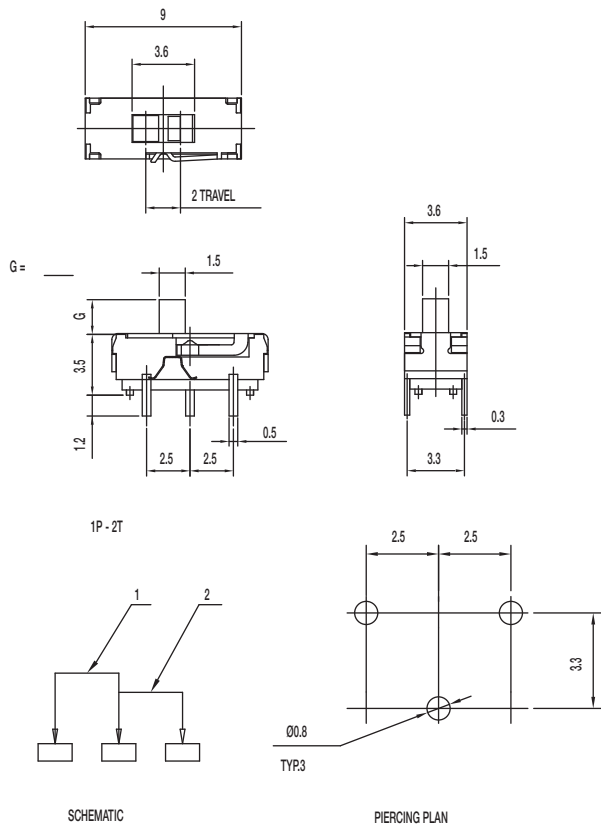

Specifications

CONTACT RATING: 0.3A @ 6 VDC
 INITIAL CONTACT RESISTANCE: 70 m ohms max.
 INSULATION RESISTANCE: 100 M ohms min.
 DIELECTRIC STRENGTH: 500 V AC (50-60 Hz) between open terminals and between the frame and terminal.
 OPERATING LIFE: 10,000 cycles with load
 OPERATING FORCE: 200 ± 100 gf (1.96 ± 0.98N)
 TRAVEL: 2 ± 0.3 mm
 OPERATING TEMPERATURE: -20°C to 80°C

Materials

KNOB: PA
 COVER: SUS
 HOUSING: PA
 CONTACT: Silver clad
 TERMINAL: Silver plated

SS-22D0205-G DPDT NON-SHORTING

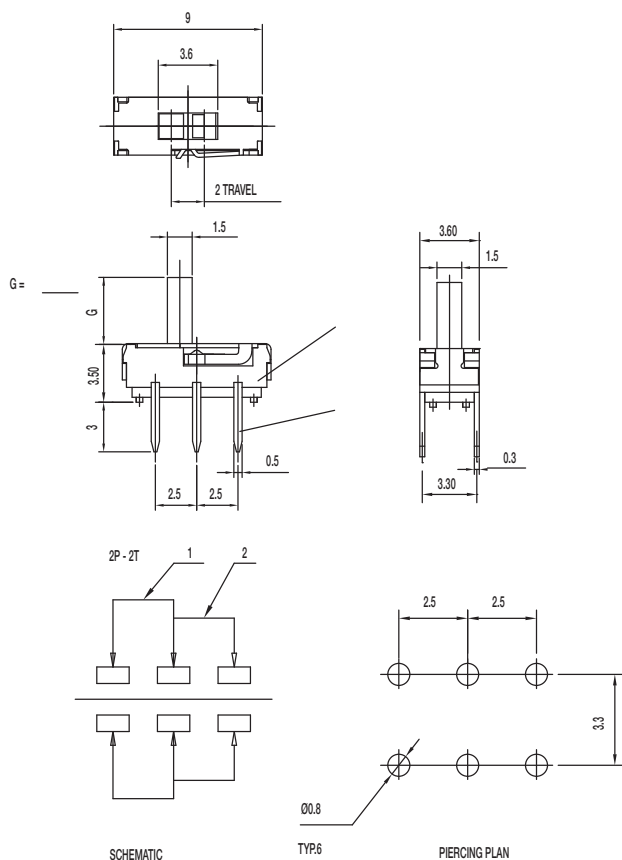

Specifications

CONTACT RATING: 0.3A @ 6 VDC
 INITIAL CONTACT RESISTANCE: 70 m ohms max.
 INSULATION RESISTANCE: 100 M ohms min.
 DIELECTRIC STRENGTH: 500 V AC (50-60 Hz) between open terminals and between the frame and terminal.
 OPERATING LIFE: 10,000 cycles with load
 OPERATING FORCE: 200 ± 100 gf (1.96 ± 0.98N)
 TRAVEL: 2 ± 0.3 mm
 OPERATING TEMPERATURE: -20°C to 80°C

Materials

KNOB: PA
 COVER: SUS
 HOUSING: PA
 CONTACT: Silver clad
 TERMINAL: Silver plated



Dimensions are shown: mm
 Specifications and dimensions subject to change

SS Series Miniature Slide Switches

SS-22D0205-G 2 -LT DPDT NON-SHORTING

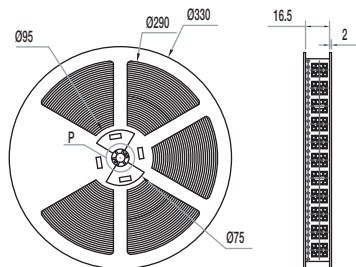
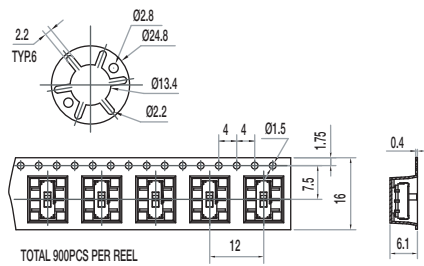
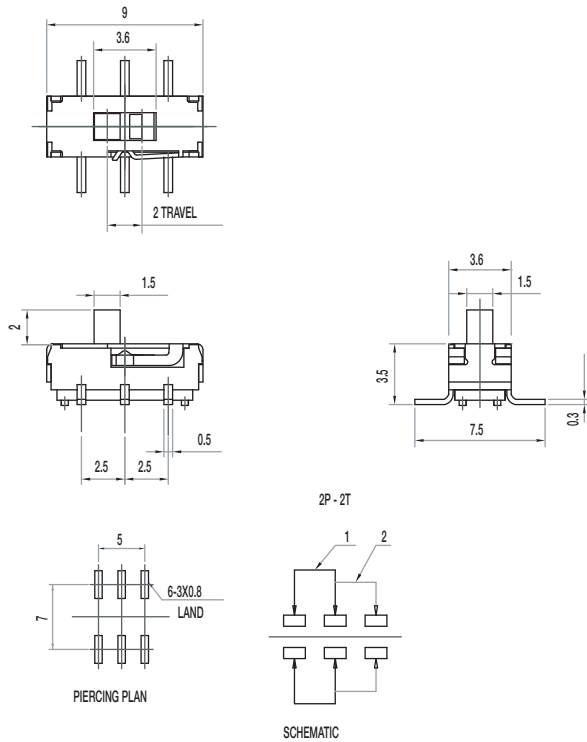

Specifications

CONTACT RATING: 0.3A @ 6 VDC
 INITIAL CONTACT RESISTANCE: 70 m ohms max.
 INSULATION RESISTANCE: 100 M ohms min.
 DIELECTRIC STRENGTH: 500 V AC (50-60 Hz) between open terminals and between the frame and terminal.
 OPERATING LIFE: 10,000 cycles with load
 OPERATING FORCE: 200 ± 100 gf (1.96 ± 0.98N)
 TRAVEL: 2 ± 0.3 mm
 OPERATING TEMPERATURE: -20°C to 70°C

Materials

KNOB: PA
 COVER: SUS
 HOUSING: PA
 CONTACT: Silver clad
 TERMINAL: Silver plated

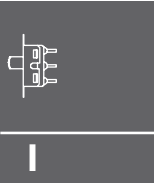

Side

SS Series Miniature Slide Switches

SS-23D31-G 1.5 NS 2P3T NON-SHORTING

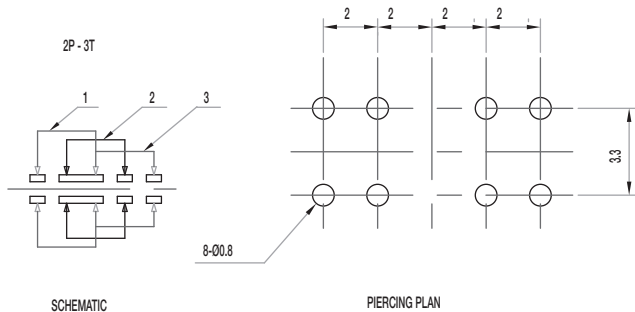
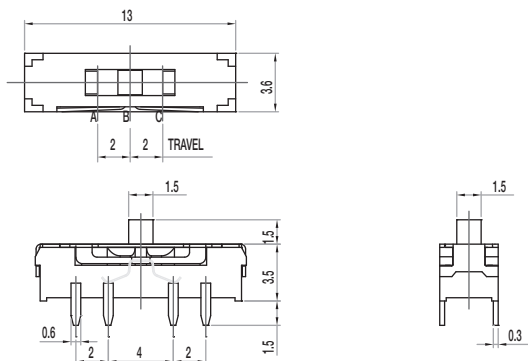

Specifications

CONTACT RATING: 0.3A @ 6 VDC
 INITIAL CONTACT RESISTANCE: 70 m ohms max.
 INSULATION RESISTANCE: 100 M ohms min.
 DIELECTRIC STRENGTH: 500 V AC (50-60 Hz) between open terminals and between the frame and terminal.
 OPERATING LIFE: 10,000 cycles with load
 OPERATING FORCE: 200 ± 100 gf (1.96 ± 0.98N)
 250 ± 100 gf (2.47 ± 0.98N)
 TRAVEL: 2 ± 0.3 mm
 OPERATING TEMPERATURE: -20°C to 70°C

Materials

KNOB: PA
 COVER: SUS
 HOUSING: PA
 CONTACT: Silver clad
 TERMINAL: Silver plated

SS-12D01-G E NS 1P2T NON-SHORTING

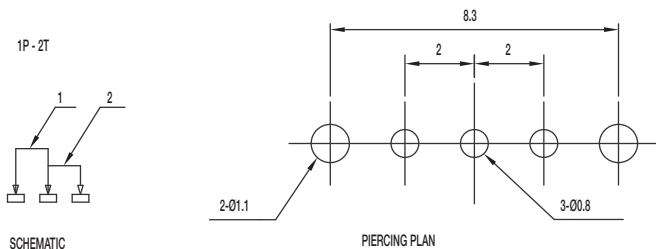
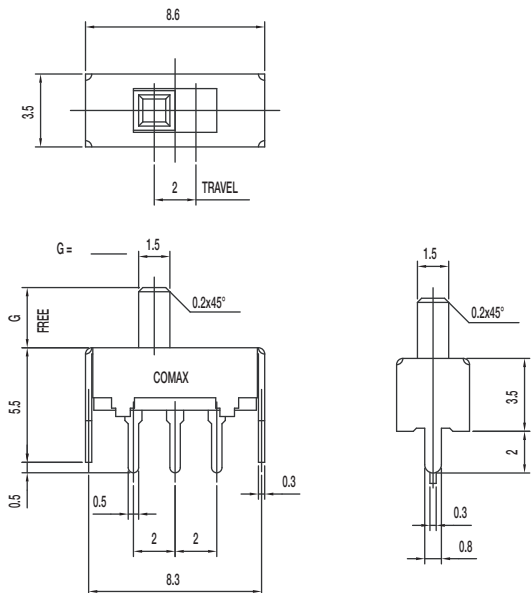

Specifications

CONTACT RATING: 0.3A @ 30 VDC
 INITIAL CONTACT RESISTANCE: 30 m ohms max.
 INSULATION RESISTANCE: 100 M ohms min.
 DIELECTRIC STRENGTH: 500 V AC (50-60 Hz) between open terminals and between the frame and terminal.
 OPERATING LIFE: 10,000 cycles with load
 OPERATING FORCE: 200 ± 100 gf (1.96 ± 0.98N)
 TRAVEL: 2 ± 0.3 mm
 OPERATING TEMPERATURE: -20°C to 70°C

Materials

KNOB: POM
 COVER: SUS
 FRAME: SPTE
 CONTACT: Silver clad
 TERMINAL: Silver plated



Dimensions are shown: mm
 Specifications and dimensions subject to change

SS Series Miniature Slide Switches

SS-12D05-G E NS 1P2T NON-SHORTING

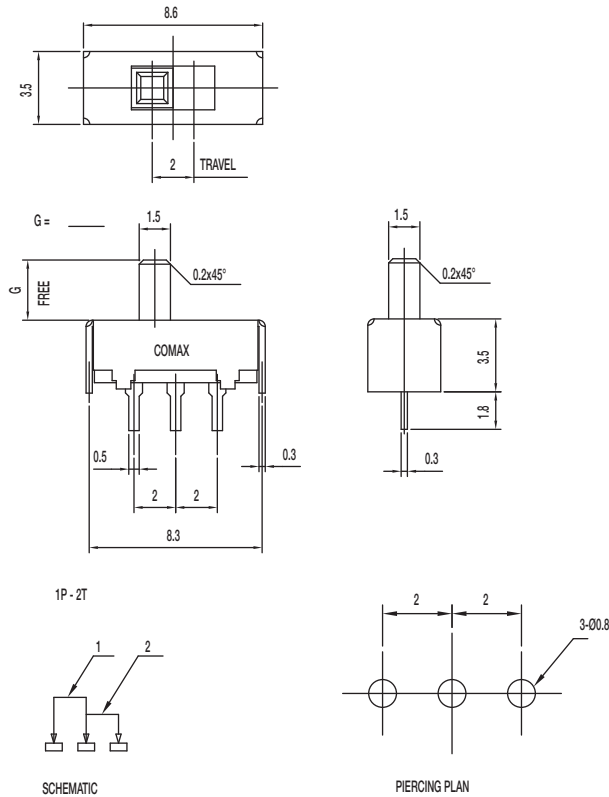

Specifications

CONTACT RATING: 0.3A @ 30 VDC
 INITIAL CONTACT RESISTANCE: 30 m ohms max.
 INSULATION RESISTANCE: 100 M ohms min.
 DIELECTRIC STRENGTH: 500 V AC (50-60 Hz) between open terminals and between the frame and terminal.
 OPERATING LIFE: 10,000 cycles with load
 OPERATING FORCE: 200 ± 100 gf (1.96 ± 0.98N)
 TRAVEL: 2 ± 0.3 mm
 OPERATING TEMPERATURE: -20°C to 70°C

Materials

KNOB: POM
 FRAME: SPTE
 CONTACT: Silver clad
 TERMINAL: Silver plated

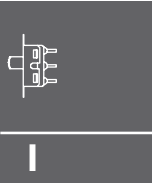

Side

SS-12D06-G E NS 1P2T NON-SHORTING

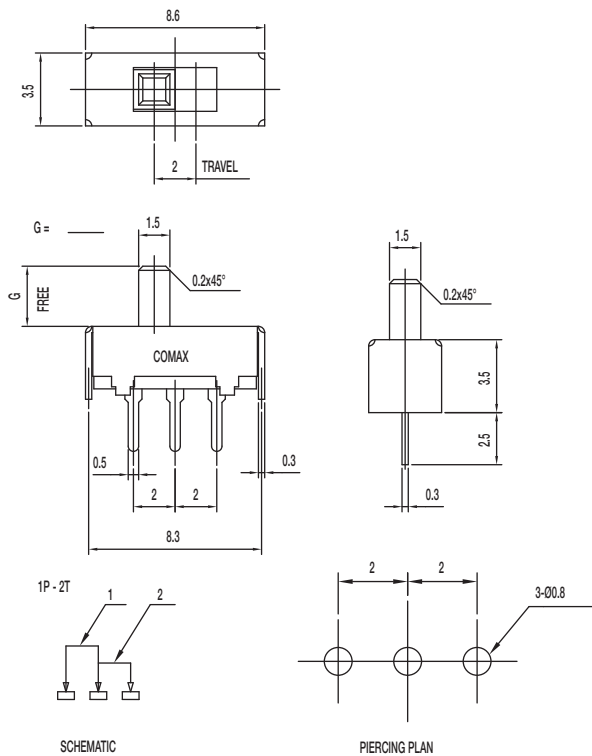

Specifications

CONTACT RATING: 0.3A @ 30 VDC
 INITIAL CONTACT RESISTANCE: 30 m ohms max.
 INSULATION RESISTANCE: 100 M ohms min.
 DIELECTRIC STRENGTH: 500 V AC (50-60 Hz) between open terminals and between the frame and terminal.
 OPERATING LIFE: 10,000 cycles with load
 OPERATING FORCE: 200 ± 100 gf (1.96 ± 0.98N)
 TRAVEL: 2 ± 0.3 mm
 OPERATING TEMPERATURE: -20°C to 70°C

Materials

KNOB: POM
 FRAME: SPTE
 CONTACT: Silver clad
 TERMINAL: Silver plated

SS Series Miniature Slide Switches

SS-12D11-G E NS 1P2T NON-SHORTING

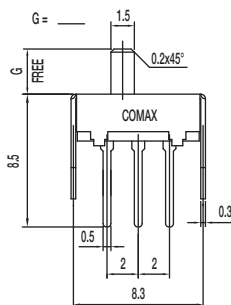
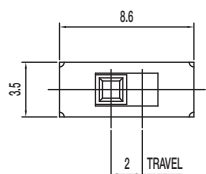

1P - 2T



SCHEMATIC

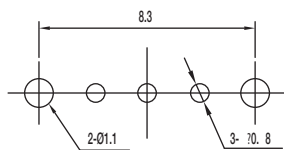
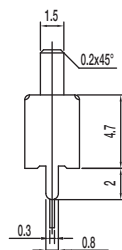

PIERCING PLAN

Specifications

CONTACT RATING: 0.3A @ 30 VDC
 INITIAL CONTACT RESISTANCE: 30 m ohms max.
 INSULATION RESISTANCE: 100 M ohms min.
 DIELECTRIC STRENGTH: 500 V AC (50-60 Hz) between open terminals and between the frame and terminal.
 OPERATING LIFE: 10,000 cycles with load
 OPERATING FORCE: 200 ± 100 gf (1.96 ± 0.98N)
 TRAVEL: 2 ± 0.3 mm
 OPERATING TEMPERATURE: -20°C to 70°C

Materials

KNOB: POM
 FRAME: SPTE
 CONTACT: Silver clad
 TERMINAL: Silver plated

SS-13D01-G 1P3T

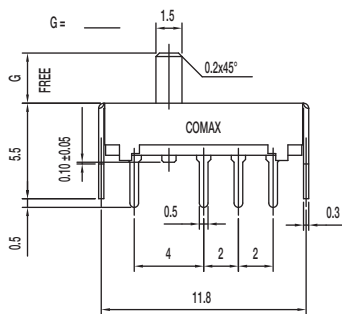
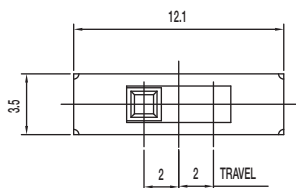

1P - 3T

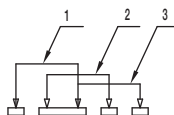

SCHEMATIC

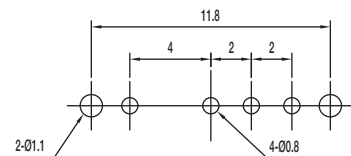
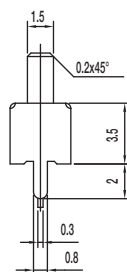

PIERCING PLAN

Specifications

CONTACT RATING: 0.3A @ 30 VDC
 INITIAL CONTACT RESISTANCE: 30 m ohms max.
 INSULATION RESISTANCE: 100 M ohms min.
 DIELECTRIC STRENGTH: 500 V AC (50-60 Hz) between open terminals and between the frame and terminal.
 OPERATING LIFE: 10,000 cycles with load
 OPERATING FORCE: 200 ± 100 gf (1.96 ± 0.98N)
 250 ± 100 gf (2.47 ± 0.98N)
 TRAVEL: 2 ± 0.3 mm
 OPERATING TEMPERATURE: -20°C to 70°C

Materials

KNOB: POM
 FRAME: SPTE
 CONTACT: Silver clad
 TERMINAL: Silver plated

SS Series Miniature Slide Switches

SS-13D04-G 1P3T

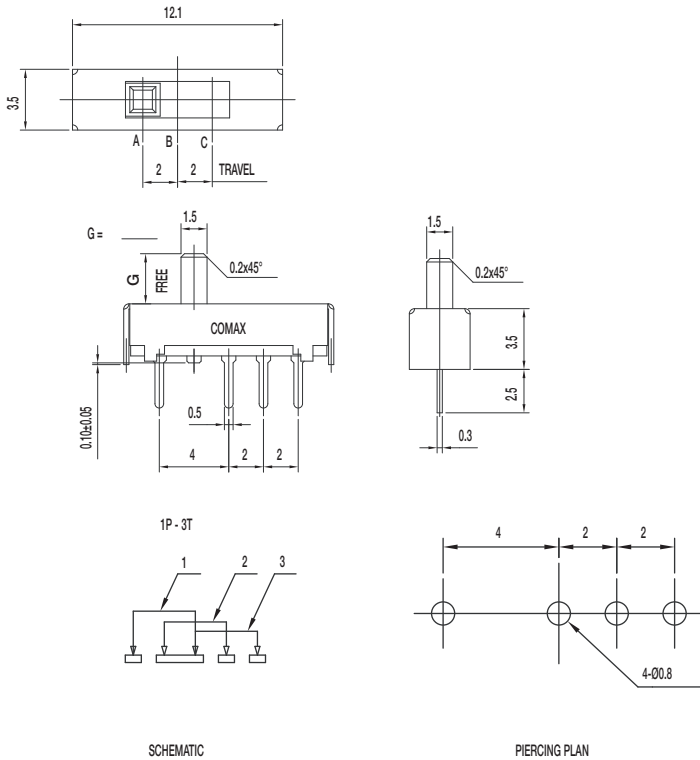

Specifications

CONTACT RATING: 0.3A @ 30 VDC
 INITIAL CONTACT RESISTANCE: 30 m ohms max.
 INSULATION RESISTANCE: 100 M ohms min.
 DIELECTRIC STRENGTH: 500 V AC (50-60 Hz) between open terminals and between the frame and terminal.
 OPERATING LIFE: 10,000 cycles with load
 OPERATING FORCE: 200 ± 100 gf (1.96 ± 0.98N)
 250 ± 100 gf (2.47 ± 0.98N)
 TRAVEL: 2 ± 0.3 mm
 OPERATING TEMPERATURE: -20°C to 70°C

Materials

KNOB: POM
 FRAME: SPTE
 CONTACT: Silver clad
 TERMINAL: Silver plated

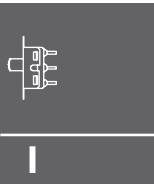

Side

SS-22D28-G NS 2P2T NON-SHORTING

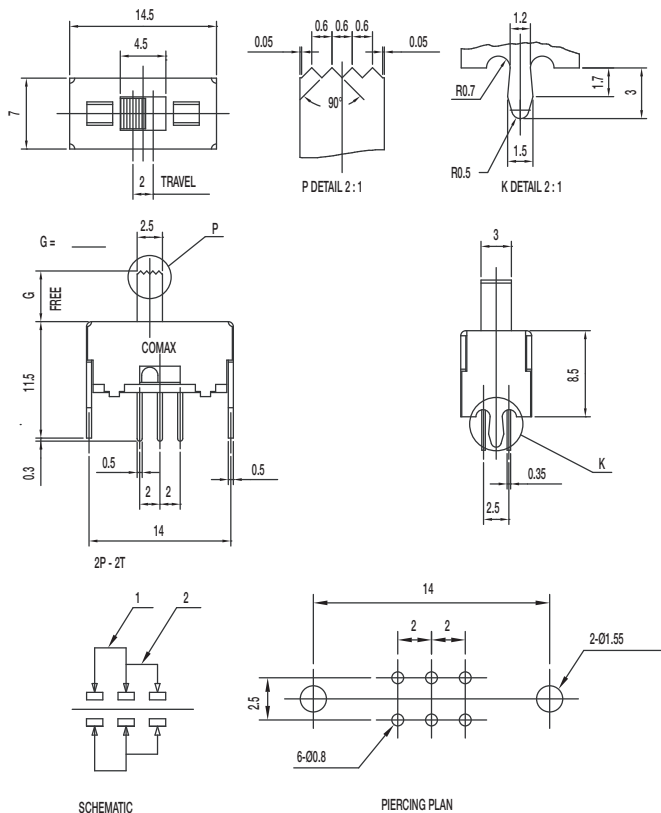

Specifications

CONTACT RATING: 0.3A @ 30 VDC
 INITIAL CONTACT RESISTANCE: 30 m ohms max.
 INSULATION RESISTANCE: 100 M ohms min.
 DIELECTRIC STRENGTH: 500 V AC (50-60 Hz) between open terminals and between the frame and terminal.
 OPERATING LIFE: 10,000 cycles with load
 OPERATING FORCE: 200 ± 100 gf (1.96 ± 0.98N)
 TRAVEL: 2 ± 0.3 mm
 OPERATING TEMPERATURE: -20°C to 70°C

Materials

KNOB: POM
 FRAME: SPCC
 CONTACT: Silver clad
 TERMINAL: Silver plated



Dimensions are shown: mm
 Specifications and dimensions subject to change

SS Series Miniature Slide Switches

SS-23D28-G NS 2P3T NON-SHORTING

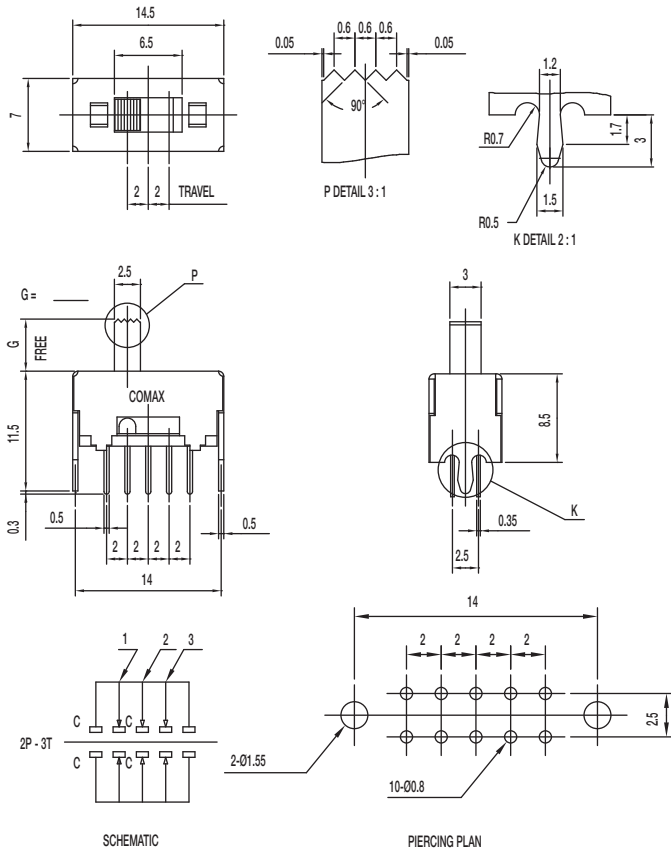

Specifications

CONTACT RATING: 0.3A @ 30 VDC
 INITIAL CONTACT RESISTANCE: 30 m ohms max.
 INSULATION RESISTANCE: 100 M ohms min.
 DIELECTRIC STRENGTH: 500 V AC (50-60 Hz) between open terminals and between the frame and terminal.
 OPERATING LIFE: 10,000 cycles with load
 OPERATING FORCE: 200 ± 100 gf (1.96 ± 0.98N)
 300 ± 150 gf (2.94 ± 1.47N)
 TRAVEL: 2 ± 0.3 mm
 OPERATING TEMPERATURE: -20°C to 70°C

Materials

KNOB: POM
 FRAME: SPCC
 CONTACT: Silver clad
 TERMINAL: Silver plated

SS-24D28-G NS 2P4T NON-SHORTING

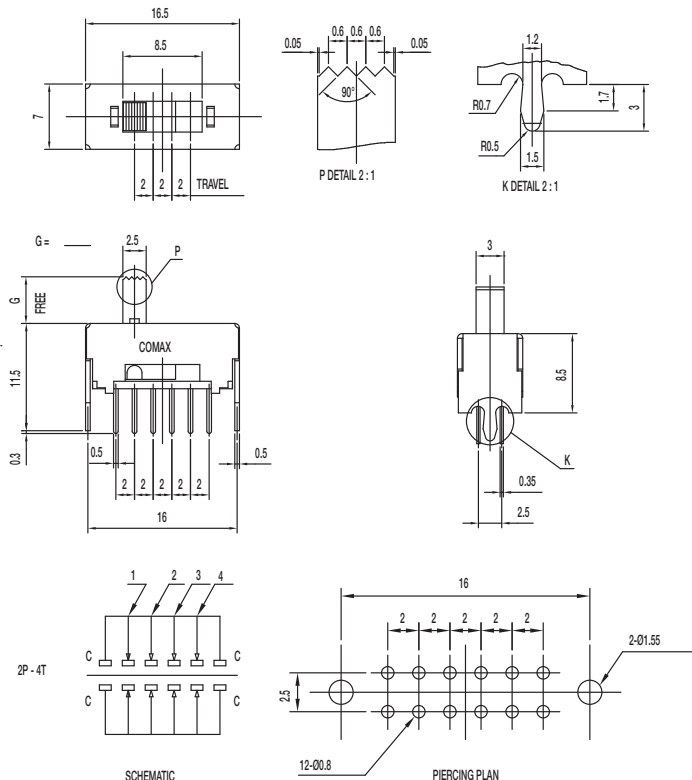

Specifications

CONTACT RATING: 0.3A @ 30 VDC
 INITIAL CONTACT RESISTANCE: 30 m ohms max.
 INSULATION RESISTANCE: 100 M ohms min.
 DIELECTRIC STRENGTH: 500 V AC (50-60 Hz) between open terminals and between the frame and terminal.
 OPERATING LIFE: 10,000 cycles with load
 OPERATING FORCE: 200 ± 100 gf (1.96 ± 0.98N)
 250 ± 100 gf (2.45 ± 0.98N); 300 ± 100 gf (2.94 ± 0.98N)
 TRAVEL: 2 ± 0.3 mm
 OPERATING TEMPERATURE: -20°C to 70°C

Materials

KNOB: POM
 FRAME: SPCC
 CONTACT: Silver clad
 TERMINAL: Silver plated



Dimensions are shown: mm
 Specifications and dimensions subject to change



SS Series Miniature Slide Switches

SS-42D28-G NS 4P2T NON-SHORTING

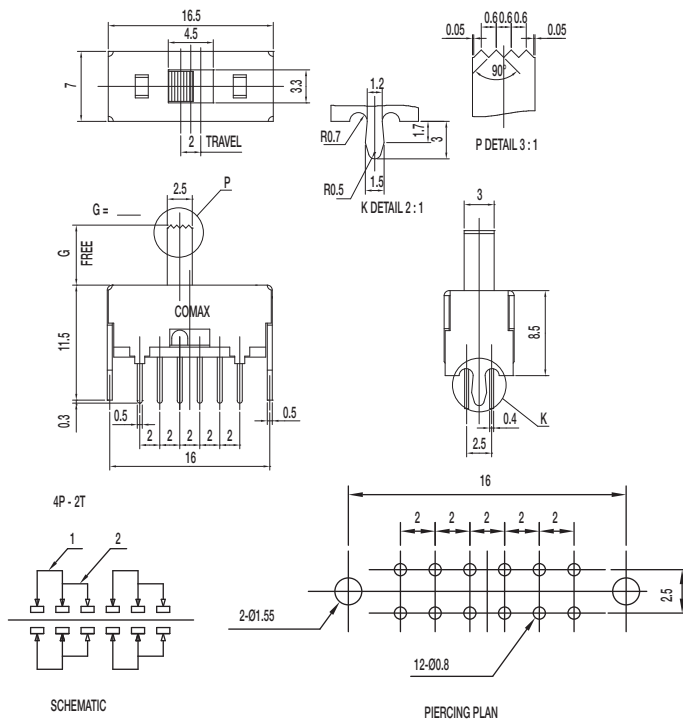

Specifications

CONTACT RATING: 0.3A @ 30 VDC
 INITIAL CONTACT RESISTANCE: 30 m ohms max.
 INSULATION RESISTANCE: 100 M ohms min.
 DIELECTRIC STRENGTH: 500 V AC (50-60 Hz) between open terminals and between the frame and terminal.
 OPERATING LIFE: 10,000 cycles with load
 OPERATING FORCE: 200 ± 100 gf (1.96 ± 0.98 N)
 TRAVEL: 2 ± 0.3 mm
 OPERATING TEMPERATURE: -20°C to 70°C

Materials

KNOB: POM
 FRAME: SPCC
 CONTACT: Silver clad
 TERMINAL: Silver plated

SS-43D28-G NS 4P3T NON-SHORTING

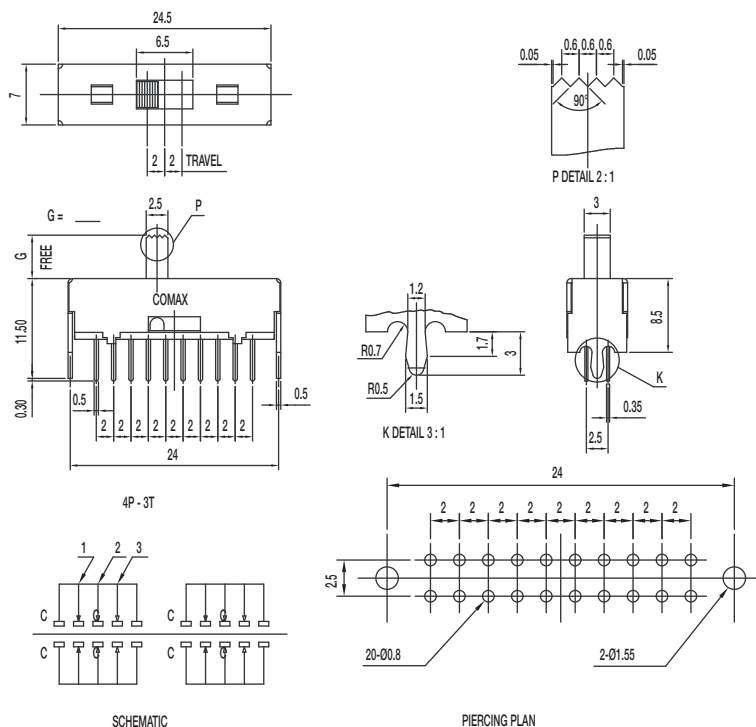

Specifications

CONTACT RATING: 0.3A @ 30 VDC
 INITIAL CONTACT RESISTANCE: 30 m ohms max.
 INSULATION RESISTANCE: 100 M ohms min.
 DIELECTRIC STRENGTH: 500 V AC (50-60 Hz) between open terminals and between the frame and terminal.
 OPERATING LIFE: 10,000 cycles with load
 OPERATING FORCE: 200 ± 100 gf (1.96 ± 0.98 N)
 300 ± 150 gf (2.94 ± 1.47 N)
 TRAVEL: 2 ± 0.3 mm
 OPERATING TEMPERATURE: -20°C to 70°C

Materials

KNOB: POM
 FRAME: SPCC
 CONTACT: Silver clad
 TERMINAL: Silver plated

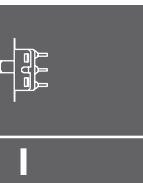

Side

SS Series Miniature Slide Switches

SS-23D32-HG NS 2P3T NON-SHORTING

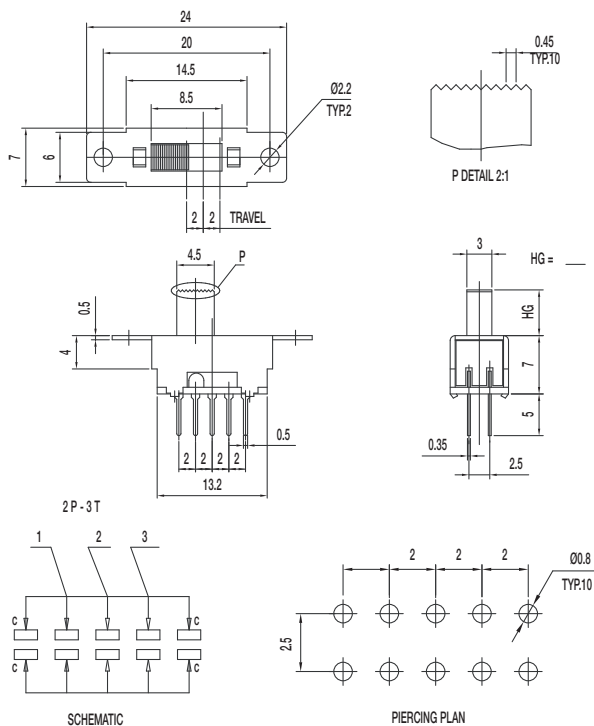

Specifications

CONTACT RATING: 0.3A @ 30 VDC
 INITIAL CONTACT RESISTANCE: 30 m ohms max.
 INSULATION RESISTANCE: 100 M ohms min.
 DIELECTRIC STRENGTH: 500 V AC (50-60 Hz) between open terminals and between the frame and terminal.
 OPERATING LIFE: 10,000 cycles with load
 OPERATING FORCE: 200 ± 100 gf (1.96 ± 0.98N)
 300 ± 100 gf (2.94 ± 0.98N)
 TRAVEL: 2 ± 0.3 mm
 OPERATING TEMPERATURE: -20°C to 70°C

Materials

KNOB: POM
 FRAME: SPCC
 CONTACT: Silver clad
 TERMINAL: Silver plated

SS-23D33-HG NS 2P3T NON-SHORTING

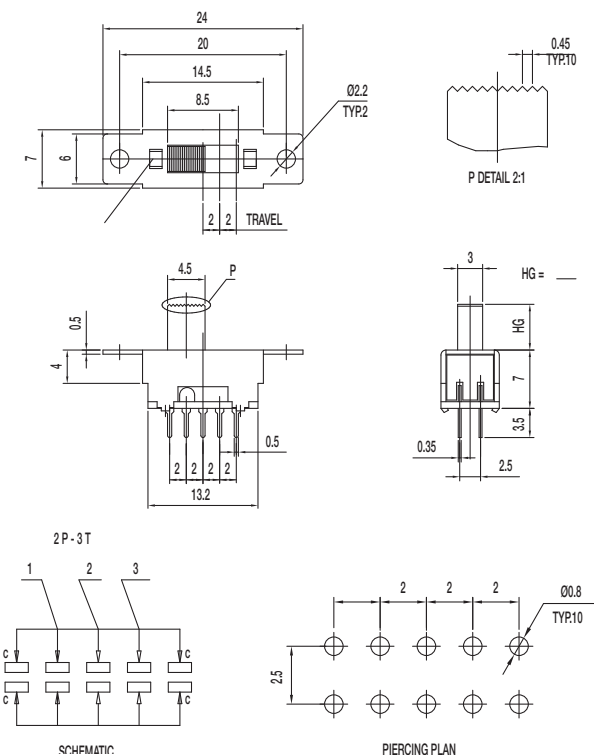

Specifications

CONTACT RATING: 0.3A @ 30 VDC
 INITIAL CONTACT RESISTANCE: 30 m ohms max.
 INSULATION RESISTANCE: 100 M ohms min.
 DIELECTRIC STRENGTH: 500 V AC (50-60 Hz) between open terminals and between the frame and terminal.
 OPERATING LIFE: 10,000 cycles with load
 OPERATING FORCE: 200 ± 100 gf (1.96 ± 0.98N)
 300 ± 100 gf (2.94 ± 0.98N)
 TRAVEL: 2 ± 0.3 mm
 OPERATING TEMPERATURE: -20°C to 70°C

Materials

KNOB: POM
 FRAME: SPCC
 CONTACT: Silver clad
 TERMINAL: Silver plated



Dimensions are shown: Inch (mm)
 Specifications and dimensions subject to change

SS Series Miniature Slide Switches

SS-23D37-G NS 2P3T NON-SHORTING

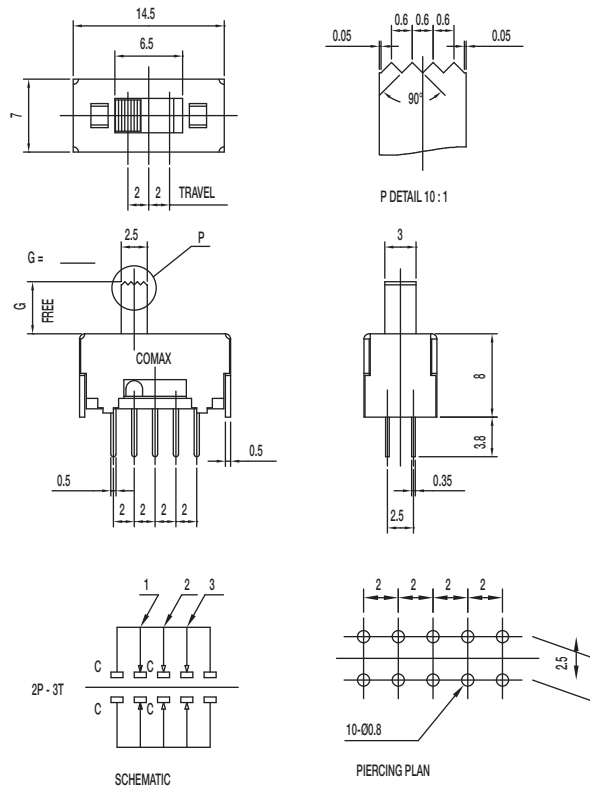

Specifications

CONTACT RATING: 0.3A @ 30 VDC
 INITIAL CONTACT RESISTANCE: 30 m ohms max.
 INSULATION RESISTANCE: 100 M ohms min.
 DIELECTRIC STRENGTH: 500 V AC (50-60 Hz) between open terminals and between the frame and terminal.
 OPERATING LIFE: 10,000 cycles with load
 OPERATING FORCE: 200 ± 100 gf (1.96 ± 0.98N)
 300 ± 100 gf (2.94 ± 0.98N)
 TRAVEL: 2 ± 0.3 mm
 OPERATING TEMPERATURE: -10°C to 60°C

Materials

KNOB: POM
 FRAME: SPCC
 CONTACT: Silver clad
 TERMINAL: Silver plated

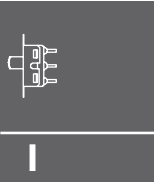

Side

SS-23D47-G NS 2P3T NON-SHORTING

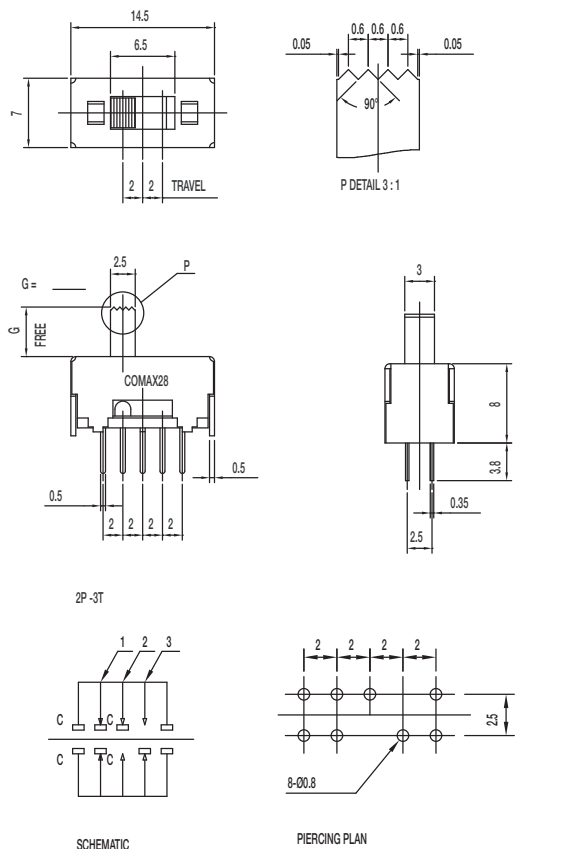

Specifications

CONTACT RATING: 0.3A @ 30 VDC
 INITIAL CONTACT RESISTANCE: 30 m ohms max.
 INSULATION RESISTANCE: 100 M ohms min.
 DIELECTRIC STRENGTH: 500 V AC (50-60 Hz) between open terminals and between the frame and terminal.
 OPERATING LIFE: 10,000 cycles with load
 OPERATING FORCE: 200 ± 100 gf (1.96 ± 0.98N)
 300 ± 100 gf (2.94 ± 0.98N)
 TRAVEL: 2 ± 0.3 mm
 OPERATING TEMPERATURE: -20°C to 70°C

Materials

KNOB: POM
 FRAME: SPCC
 CONTACT: Silver clad
 TERMINAL: Silver plated



Dimensions are shown: mm
 Specifications and dimensions subject to change

SS Series Miniature Slide Switches

SS-12F28-G NS 1P2T NON-SHORTING

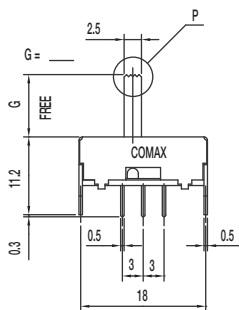
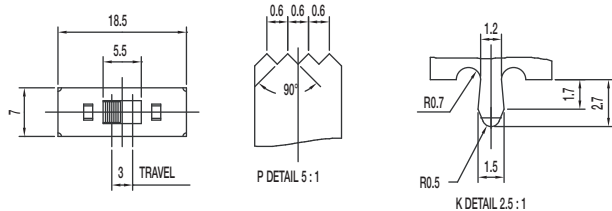

1P - 2T

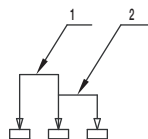

SCHEMATIC

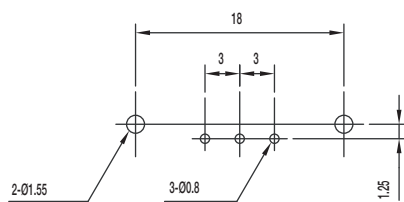

PIERCING PLAN

Specifications

CONTACT RATING: 0.3A @ 30 VDC
 INITIAL CONTACT RESISTANCE: 30 m ohms max.
 INSULATION RESISTANCE: 100 M ohms min.
 DIELECTRIC STRENGTH: 500 V AC (50-60 Hz) between open terminals and between the frame and terminal.
 OPERATING LIFE: 10,000 cycles with load
 OPERATING FORCE: 200 ± 100 gf (1.96 ± 0.98N)
 TRAVEL: 3 ± 0.3 mm
 OPERATING TEMPERATURE: -20°C to 70°C

Materials

KNOB: POM
 FRAME: SPCC
 CONTACT: Silver clad
 TERMINAL: Silver plated

SS-13F28-G NS 1P3T NON-SHORTING

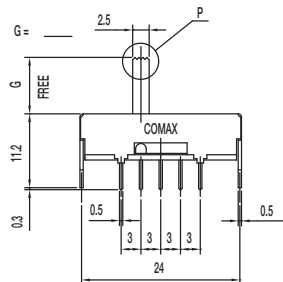
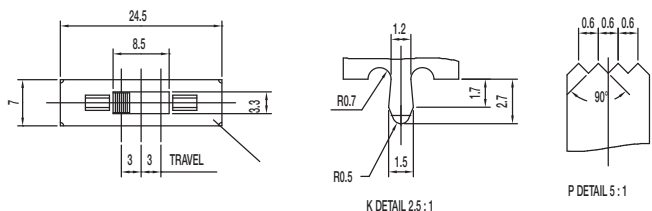

1P - 3T

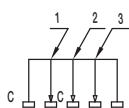

SCHEMATIC

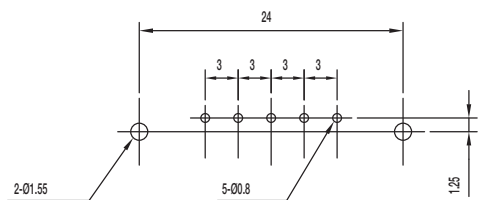

PIERCING PLAN

Specifications

CONTACT RATING: 0.3A @ 30 VDC
 INITIAL CONTACT RESISTANCE: 30 m ohms max.
 INSULATION RESISTANCE: 100 M ohms min.
 DIELECTRIC STRENGTH: 500 V AC (50-60 Hz) between open terminals and between the frame and terminal.
 OPERATING LIFE: 10,000 cycles with load
 OPERATING FORCE: 180 ± 50 gf (1.76 ± 0.49N)
 220 ± 100 gf (2.16 ± 0.98N)
 TRAVEL: 3 ± 0.3 mm
 OPERATING TEMPERATURE: -20°C to 70°C

Materials

KNOB: POM
 FRAME: SPCC
 CONTACT: Silver clad
 TERMINAL: Silver plated

Dimensions are shown: mm
 Specifications and dimensions subject to change



SS Series Miniature Slide Switches

SS-22F28-G S DPDT SHORTING

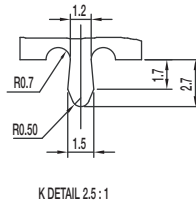
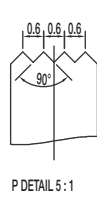
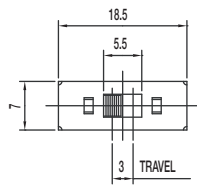

Specifications

CONTACT RATING: 0.3A @ 30 VDC
 INITIAL CONTACT RESISTANCE: 30 m ohms max.
 INSULATION RESISTANCE: 100 M ohms min.
 DIELECTRIC STRENGTH: 500 V AC (50-60 Hz) between open terminals and between the frame and terminal.
 OPERATING LIFE: 10,000 cycles with load
 OPERATING FORCE: 200 ± 100 gf (1.96 ± 0.98N)
 TRAVEL: 3 ± 0.3 mm
 OPERATING TEMPERATURE: -20°C to 70°C

Materials

KNOB: POM
 FRAME: SPCC
 CONTACT: Silver clad
 TERMINAL: Silver plated

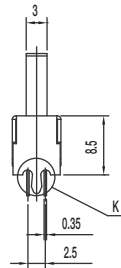
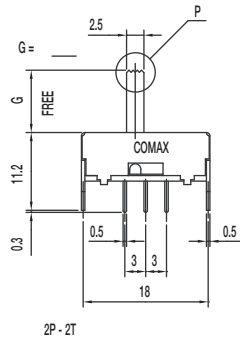

2P-2T

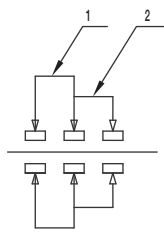

SCHEMATIC

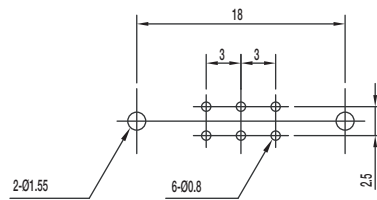

PIERCING PLAN

SS-23F28-G 6 NS 2P3T NON-SHORTING

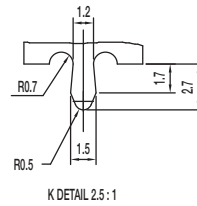
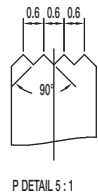
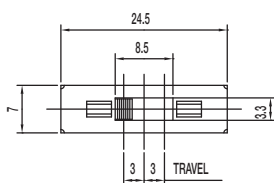

Specifications

CONTACT RATING: 0.3A @ 30 VDC
 INITIAL CONTACT RESISTANCE: 30 m ohms max.
 INSULATION RESISTANCE: 100 M ohms min.
 DIELECTRIC STRENGTH: 500 V AC (50-60 Hz) between open terminals and between the frame and terminal.
 OPERATING LIFE: 10,000 cycles with load
 OPERATING FORCE: 180 ± 50 gf (1.76 ± 0.49N) (A->B / C->B)
 220 ± 100 gf (2.16 ± 0.98N) (B->C / B->A)
 TRAVEL: 3 ± 0.3 mm
 OPERATING TEMPERATURE: -20°C to 70°C
 KNOB LENGTH: 6mm

Materials

KNOB: POM
 FRAME: SPCC
 CONTACT: Silver clad
 TERMINAL: Silver plated

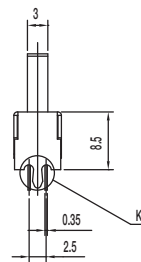
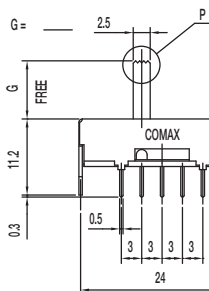

2P-3T

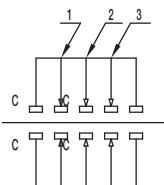

SCHEMATIC

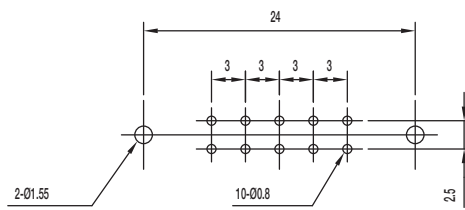

PIERCING PLAN



Dimensions are shown: mm
 Specifications and dimensions subject to change

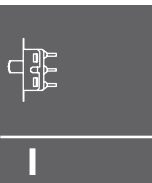

Side

SS Series Miniature Slide Switches

SS-24F28-G 2P4T NON-SHORTING

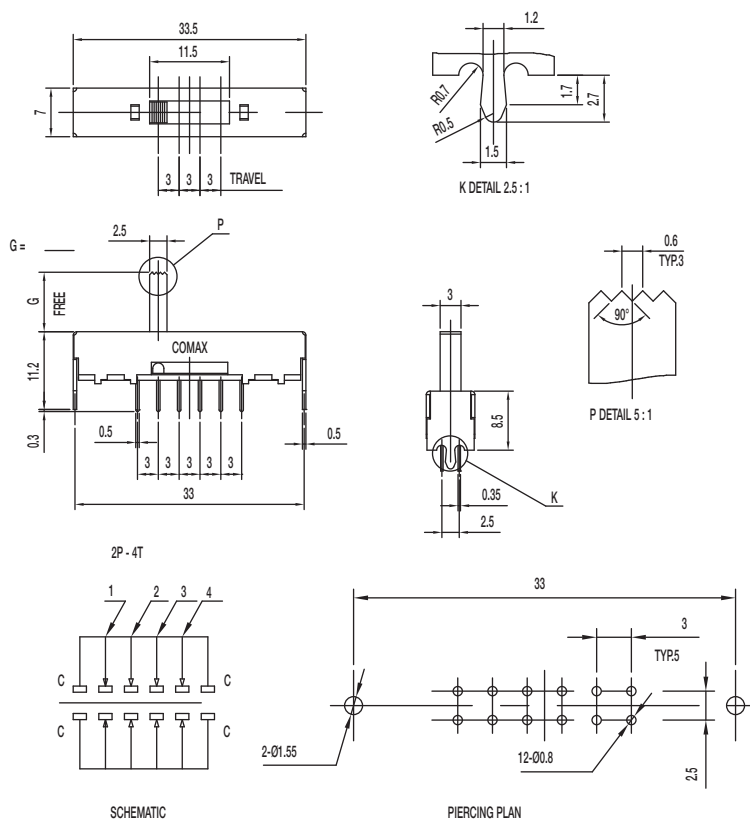

Specifications

CONTACT RATING: 0.3A @ 30 VDC
 INITIAL CONTACT RESISTANCE: 30 m ohms max.
 INSULATION RESISTANCE: 100 M ohms min.
 DIELECTRIC STRENGTH: 500 V AC (50-60 Hz) between open terminals and between the frame and terminal.
 OPERATING LIFE: 10,000 cycles with load
 OPERATING FORCE: 200 ± 100 gf (1.96 ± 0.98N)
 250 ± 100 gf (2.45 ± 0.98N)
 TRAVEL: 3 ± 0.3 mm
 OPERATING TEMPERATURE: -20°C to 70°C

Materials

KNOB: POM
 FRAME: SPCC
 CONTACT: Silver clad
 TERMINAL: Silver plated

SS-42F28-G NS 4P2T NON-SHORTING

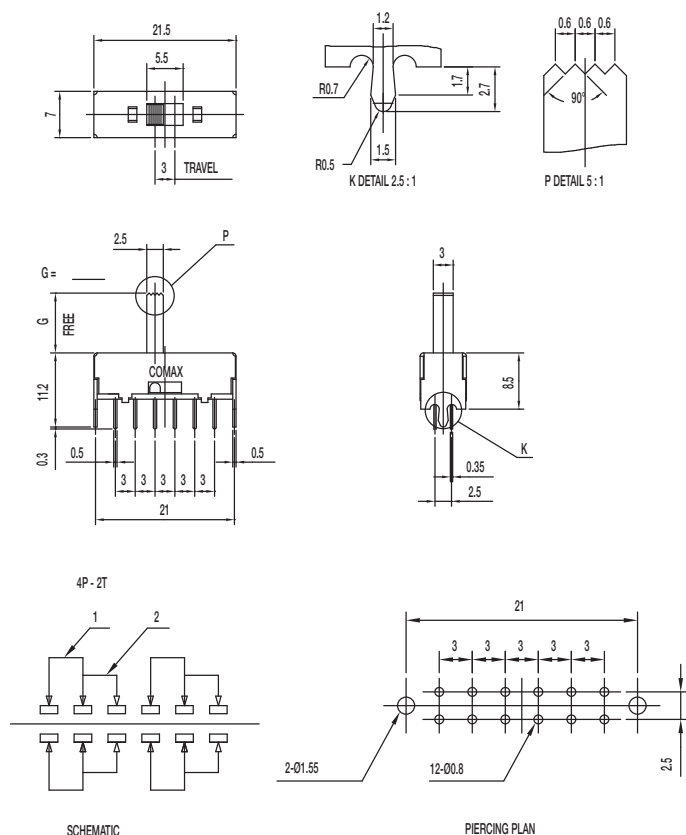

Specifications

CONTACT RATING: 0.3A @ 30 VDC
 INITIAL CONTACT RESISTANCE: 30 m ohms max.
 INSULATION RESISTANCE: 100 M ohms min.
 DIELECTRIC STRENGTH: 500 V AC (50-60 Hz) between open terminals and between the frame and terminal.
 OPERATING LIFE: 10,000 cycles with load
 OPERATING FORCE: 200 ± 100 gf (1.96 ± 0.98N)
 TRAVEL: 3 ± 0.3 mm
 OPERATING TEMPERATURE: -20°C to 70°C

Materials

KNOB: POM
 FRAME: SPCC
 CONTACT: Silver clad
 TERMINAL: Silver plated

SS Series Miniature Slide Switches

SS-43F28-G NS 4P3T NON-SHORTING

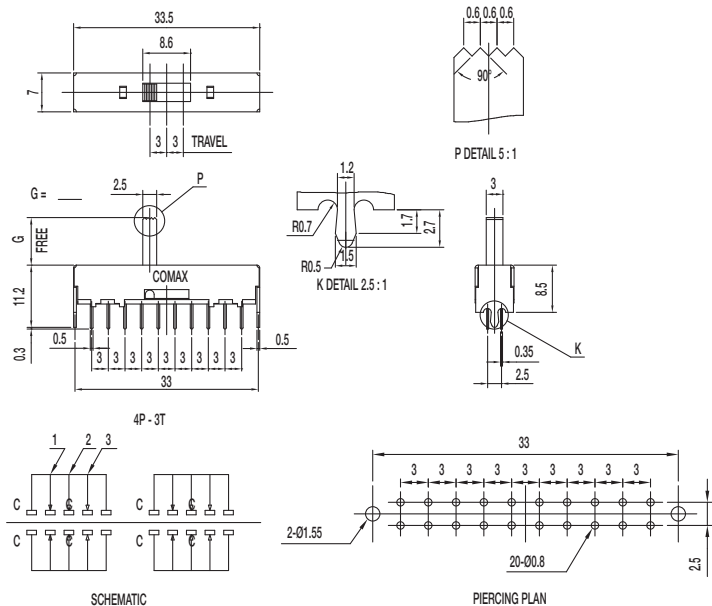

Specifications

CONTACT RATING: 0.3A @ 30 VDC
 INITIAL CONTACT RESISTANCE: 30 m ohms max.
 INSULATION RESISTANCE: 100 M ohms min.
 DIELECTRIC STRENGTH: 500 V AC (50-60 Hz) between open terminals and between the frame and terminal.
 OPERATING LIFE: 10,000 cycles with load
 OPERATING FORCE: 200 ± 100 gf (1.96 ± 0.98N)
 250 ± 100 gf (2.45 ± 0.98N)
 TRAVEL: 3 ± 0.3 mm
 OPERATING TEMPERATURE: -20°C to 70°C

Materials

KNOB: POM
 FRAME: SPCC
 CONTACT: Silver clad
 TERMINAL: Silver plated

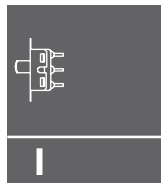

Side

SS-44F28-G NS 4P4T NON-SHORTING

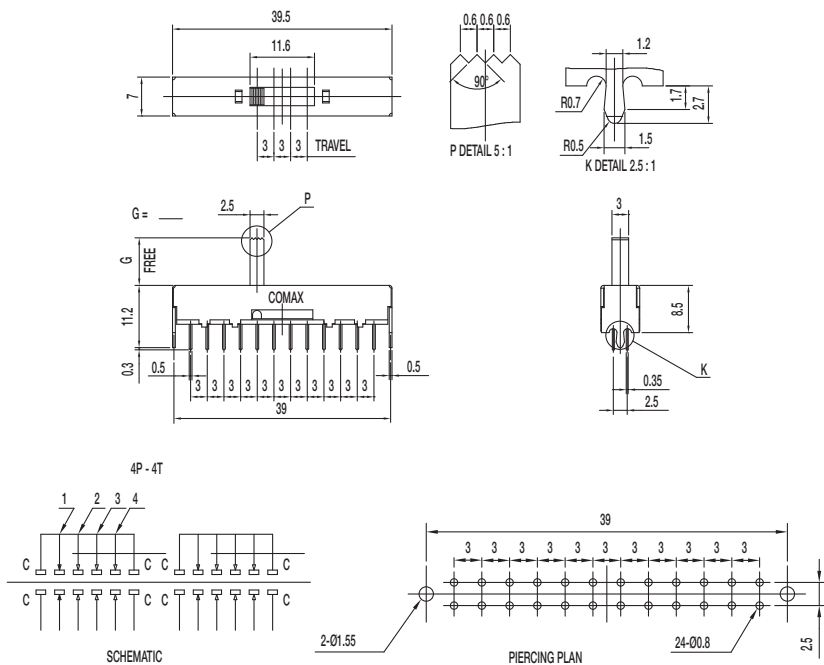

Specifications

CONTACT RATING: 0.3A @ 30 VDC
 INITIAL CONTACT RESISTANCE: 30 m ohms max.
 INSULATION RESISTANCE: 100 M ohms min.
 DIELECTRIC STRENGTH: 500 V AC (50-60 Hz) between open terminals and between the frame and terminal.
 OPERATING LIFE: 10,000 cycles with load
 OPERATING FORCE: 200 ± 100 gf (1.96 ± 0.98N)
 250 ± 100 gf (2.45 ± 0.98N)
 TRAVEL: 3 ± 0.3 mm
 OPERATING TEMPERATURE: -20°C to 70°C

Materials

KNOB: POM
 FRAME: SPCC
 CONTACT: Silver clad
 TERMINAL: Silver plated

SS Series Miniature Slide Switches

SS-12D04-VG NS 1P2T NON-SHORTING

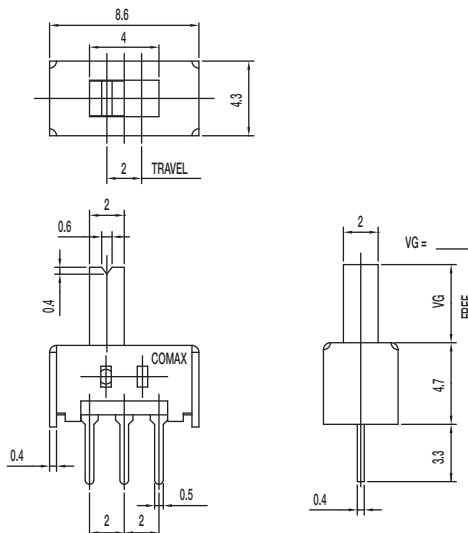

1P-2T

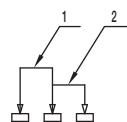

SCHEMATIC

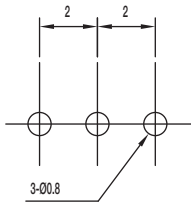

PIERCING PLAN

Specifications

CONTACT RATING: 0.3A @ 30 VDC
 INITIAL CONTACT RESISTANCE: 30 m ohms max.
 INSULATION RESISTANCE: 100 M ohms min.
 DIELECTRIC STRENGTH: 500 V AC (50-60 Hz) between open terminals and between the frame and terminal.
 OPERATING LIFE: 10,000 cycles with load
 OPERATING FORCE: 200 ± 100 gf (1.96 ± 0.98N)
 TRAVEL: 2 ± 0.3 mm
 OPERATING TEMPERATURE: -20°C to 70°C

Materials

KNOB: POM
 FRAME: SPTE
 CONTACT: Silver clad
 TERMINAL: Silver plated

SS-12D07-G NS 1P2T NON-SHORTING

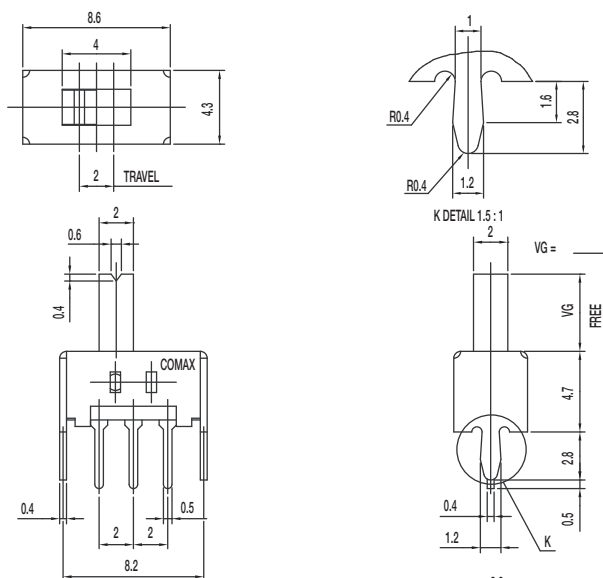

1P-2T

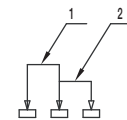

SCHEMATIC

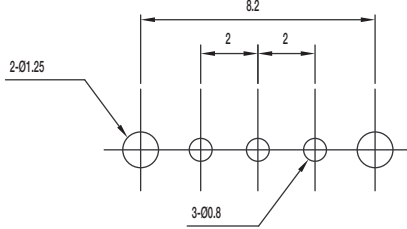

PIERCING PLAN

Specifications

CONTACT RATING: 0.3A @ 30 VDC
 INITIAL CONTACT RESISTANCE: 30 m ohms max.
 INSULATION RESISTANCE: 100 M ohms min.
 DIELECTRIC STRENGTH: 500 V AC (50-60 Hz) between open terminals and between the frame and terminal.
 OPERATING LIFE: 10,000 cycles with load
 OPERATING FORCE: 250 ± 100 gf (2.45 ± 0.98N)
 TRAVEL: 2 ± 0.3 mm
 OPERATING TEMPERATURE: -20°C to 70°C

Materials

KNOB: POM
 FRAME: SPCC
 CONTACT: Silver clad
 TERMINAL: Silver plated



Dimensions are shown: mm
 Specifications and dimensions subject to change

SS Series Miniature Slide Switches

SS-12D17-VG NS 1P2T NON-SHORTING

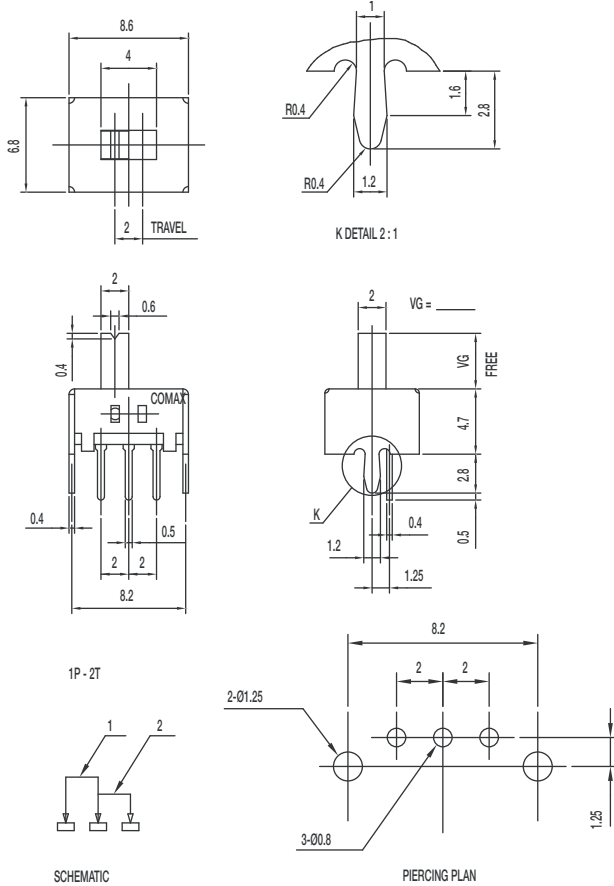

Specifications

CONTACT RATING: 0.3A @ 30 VDC
 INITIAL CONTACT RESISTANCE: 30 m ohms max.
 INSULATION RESISTANCE: 100 M ohms min.
 DIELECTRIC STRENGTH: 500 V AC (50-60 Hz) between open terminals and between the frame and terminal.
 OPERATING LIFE: 10,000 cycles with load
 OPERATING FORCE: 250 ± 100 gf (2.45 ± 0.98N)
 TRAVEL: 2 ± 0.3 mm
 OPERATING TEMPERATURE: -20°C to 70°C

Materials

KNOB: POM
 FRAME: SPCC
 CONTACT: Silver clad
 TERMINAL: Silver plated

SS-12H16-VG 1P2T NON-SHORTING

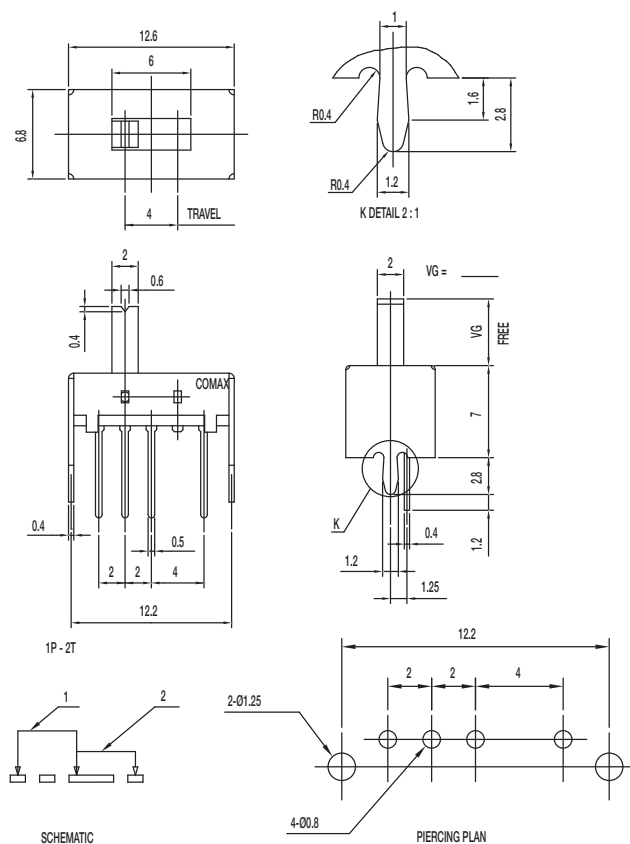

Specifications

CONTACT RATING: 0.3A @ 30 VDC
 INITIAL CONTACT RESISTANCE: 30 m ohms max.
 INSULATION RESISTANCE: 100 M ohms min.
 DIELECTRIC STRENGTH: 500 V AC (50-60 Hz) between open terminals and between the frame and terminal.
 OPERATING LIFE: 10,000 cycles with load
 OPERATING FORCE: 200 ± 100 gf (1.96 ± 0.98N)
 TRAVEL: 4 ± 0.3 mm
 OPERATING TEMPERATURE: -20°C to 70°C

Materials

KNOB: POM
 FRAME: SPCC
 CONTACT: Silver clad
 TERMINAL: Silver plated



Dimensions are shown: mm
 Specifications and dimensions subject to change

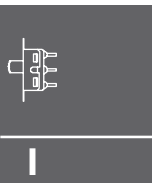

Slide

SS Series Miniature Slide Switches

SS-12H26-VG 1P2T NON-SHORTING

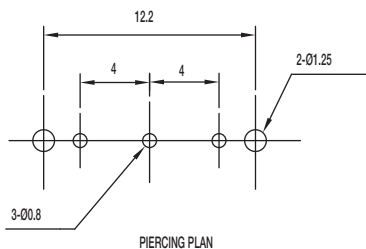
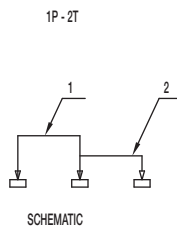
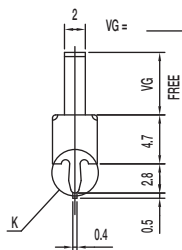
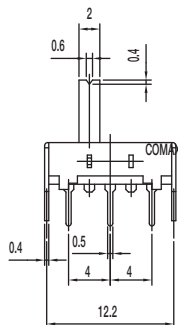
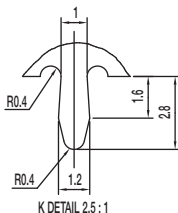
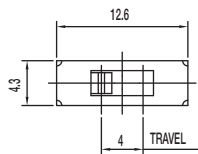

Specifications

CONTACT RATING: 0.3A @ 30 VDC
 INITIAL CONTACT RESISTANCE: 30 m ohms max.
 INSULATION RESISTANCE: 100 M ohms min.
 DIELECTRIC STRENGTH: 500 V AC (50-60 Hz) between open terminals and between the frame and terminal.
 OPERATING LIFE: 10,000 cycles with load
 OPERATING FORCE: 150 ± 100 gf (1.47 ± 0.98N)
 TRAVEL: 2 ± 0.3 mm
 OPERATING TEMPERATURE: -20°C to 70°C

Materials

KNOB: POM
 FRAME: SPCC
 CONTACT: Silver clad
 TERMINAL: Silver plated

SS-13D06-VG 1P3T

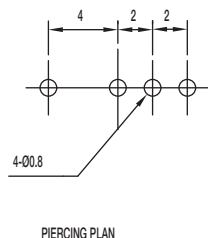
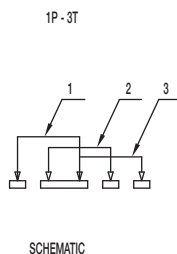
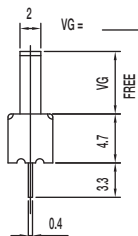
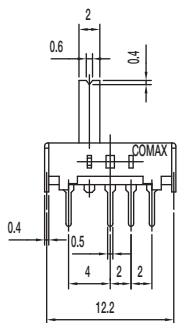
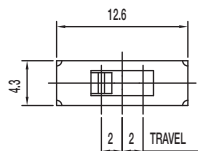

Specifications

CONTACT RATING: 0.3A @ 30 VDC
 INITIAL CONTACT RESISTANCE: 30 m ohms max.
 INSULATION RESISTANCE: 100 M ohms min.
 DIELECTRIC STRENGTH: 500 V AC (50-60 Hz) between open terminals and between the frame and terminal.
 OPERATING LIFE: 10,000 cycles with load
 OPERATING FORCE: 200 ± 100 gf (1.96 ± 0.98N)
 250 ± 100 gf (2.45 ± 0.98N)
 TRAVEL: 2 ± 0.3 mm
 OPERATING TEMPERATURE: -20°C to 70°C

Materials

KNOB: POM
 FRAME: SPCC
 CONTACT: Silver clad
 TERMINAL: Silver plated



Dimensions are shown: mm
 Specifications and dimensions subject to change

SS Series Miniature Slide Switches

SS-13D08-VG 1P3T

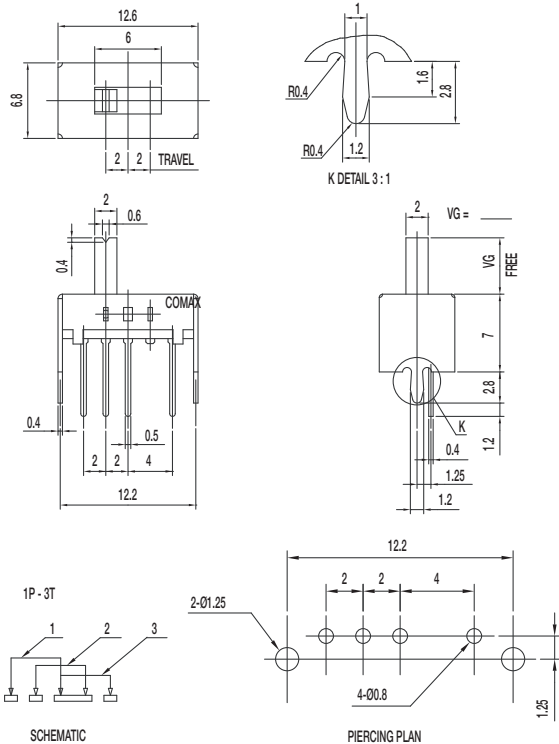

Specifications

CONTACT RATING: 0.3A @ 30 VDC
 INITIAL CONTACT RESISTANCE: 30 m ohms max.
 INSULATION RESISTANCE: 100 M ohms min.
 DIELECTRIC STRENGTH: 500 V AC (50-60 Hz) between open terminals and between the frame and terminal.
 OPERATING LIFE: 10,000 cycles with load
 OPERATING FORCE: 150 ± 50 gf (1.47 ± 0.49N)
 200 ± 100 gf (1.96 ± 0.98N)
 TRAVEL: 2 ± 0.3 mm
 OPERATING TEMPERATURE: -20°C to 70°C

Materials

KNOB: POM
 FRAME: SPCC
 CONTACT: Silver clad
 TERMINAL: Silver plated

SS-13D16-VG 1P3T

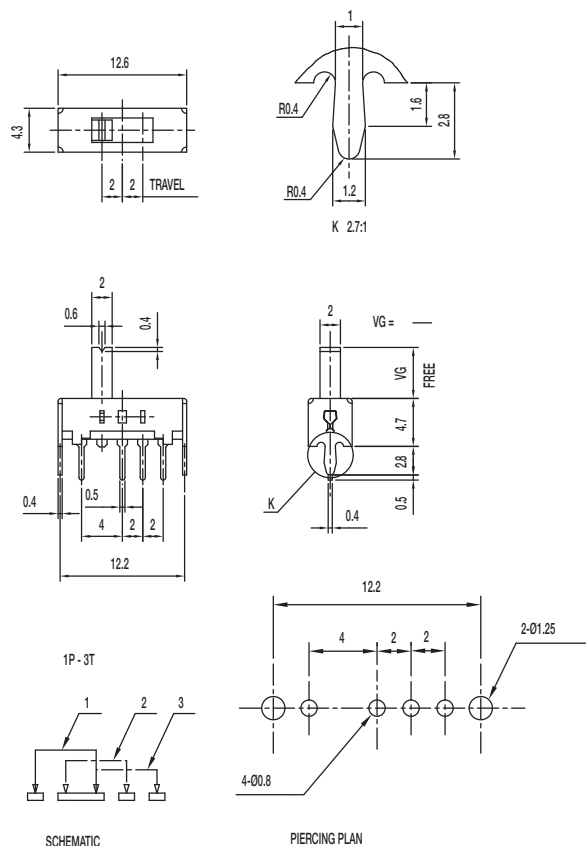

Specifications

CONTACT RATING: 0.3A @ 30 VDC
 INITIAL CONTACT RESISTANCE: 30 m ohms max.
 INSULATION RESISTANCE: 100 M ohms min.
 DIELECTRIC STRENGTH: 500 V AC (50-60 Hz) between open terminals and between the frame and terminal.
 OPERATING LIFE: 10,000 cycles with load
 OPERATING FORCE: 200 ± 100 gf (1.96 ± 0.98N)
 250 ± 100 gf (2.45 ± 0.98N)
 TRAVEL: 2 ± 0.3 mm
 OPERATING TEMPERATURE: -20°C to 70°C

Materials

KNOB: POM
 FRAME: SPCC
 CONTACT: Silver clad
 TERMINAL: Silver plated



Dimensions are shown: mm
 Specifications and dimensions subject to change

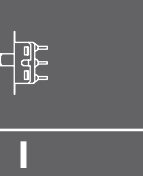

Slide

SS Series Miniature Slide Switches

SS-14D01-VG 1P4T

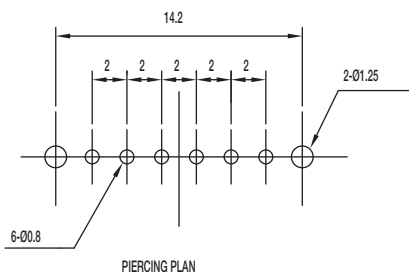
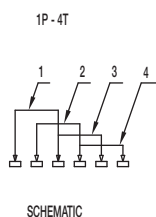
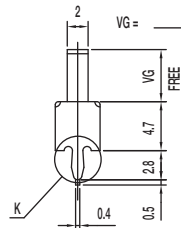
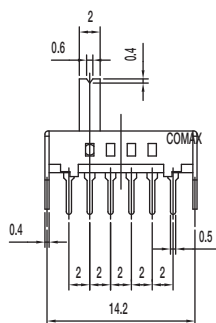
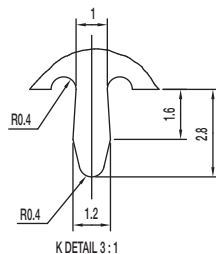
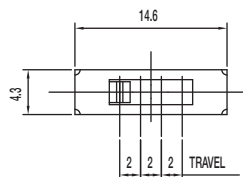

Specifications

CONTACT RATING: 0.3A @ 30 VDC
 INITIAL CONTACT RESISTANCE: 30 m ohms max.
 INSULATION RESISTANCE: 100 M ohms min.
 DIELECTRIC STRENGTH: 500 V AC (50-60 Hz) between open terminals and between the frame and terminal.
 OPERATING LIFE: 10,000 cycles with load
 OPERATING FORCE: 200 ± 100 gf (1.96 ± 0.98N)
 TRAVEL: 2 ± 0.3 mm
 OPERATING TEMPERATURE: -20°C to 70°C

Materials

KNOB: POM
 FRAME: SPCC
 CONTACT: Silver clad
 TERMINAL: Silver plated

SS-14D07-VG 1P4T

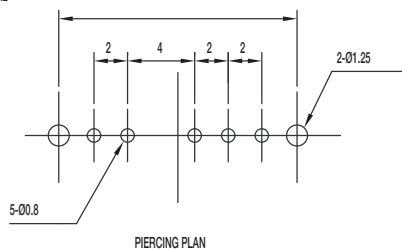
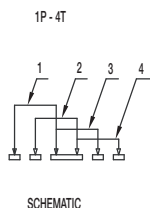
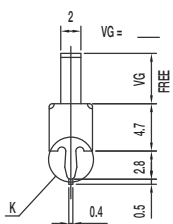
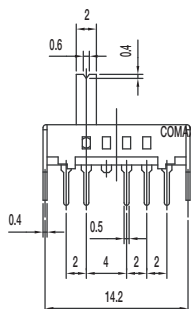
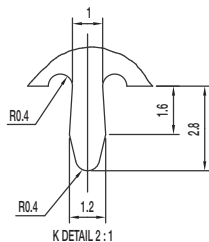
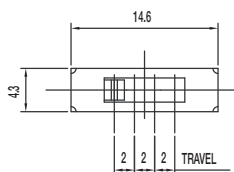

Specifications

CONTACT RATING: 0.3A @ 30 VDC
 INITIAL CONTACT RESISTANCE: 30 m ohms max.
 INSULATION RESISTANCE: 100 M ohms min.
 DIELECTRIC STRENGTH: 500 V AC (50-60 Hz) between open terminals and between the frame and terminal.
 OPERATING LIFE: 10,000 cycles with load
 OPERATING FORCE: 200 ± 100 gf (1.96 ± 0.98N)
 TRAVEL: 2 ± 0.3 mm
 OPERATING TEMPERATURE: -20°C to 70°C

Materials

KNOB: POM
 FRAME: SPCC
 CONTACT: Silver clad
 TERMINAL: Silver plated



Dimensions are shown: mm
 Specifications and dimensions subject to change

SS Series Miniature Slide Switches

SS-22D07-VG S DPDT SHORTING

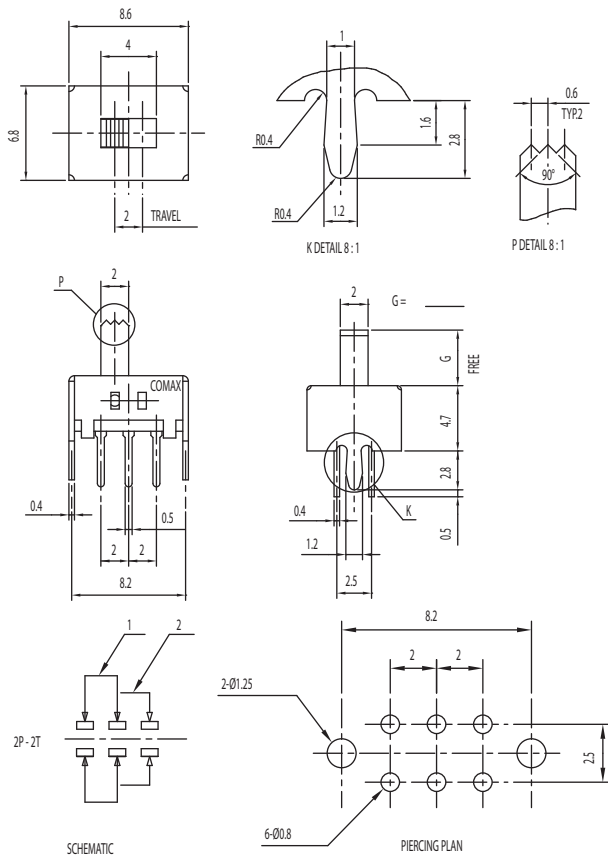

Specifications

CONTACT RATING: 0.3A @ 30 VDC
 INITIAL CONTACT RESISTANCE: 30 m ohms max.
 INSULATION RESISTANCE: 100 M ohms min.
 DIELECTRIC STRENGTH: 500 V AC (50-60 Hz) between open terminals and between the frame and terminal.
 OPERATING LIFE: 10,000 cycles with load
 OPERATING FORCE: 250 ± 100 gf (2.45 ± 0.98N)
 TRAVEL: 2 ± 0.3 mm
 OPERATING TEMPERATURE: -20°C to 70°C

Materials

KNOB: POM
 FRAME: SPCC
 CONTACT: Silver clad
 TERMINAL: Silver plated

SS-22H08-G DPDT NON-SHORTING

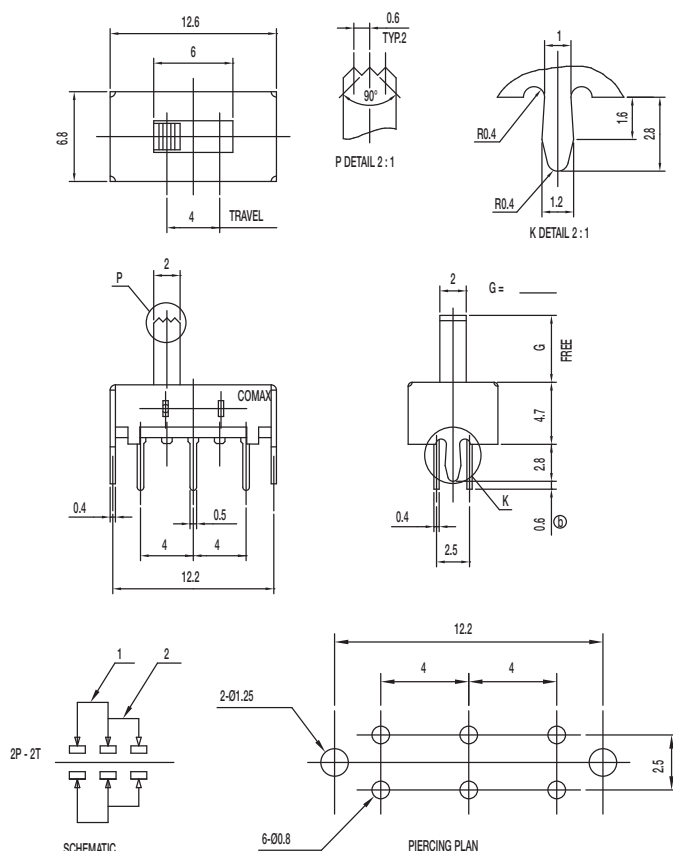

Specifications

CONTACT RATING: 0.3A @ 30 VDC
 INITIAL CONTACT RESISTANCE: 30 m ohms max.
 INSULATION RESISTANCE: 100 M ohms min.
 DIELECTRIC STRENGTH: 500 V AC (50-60 Hz) between open terminals and between the frame and terminal.
 OPERATING LIFE: 10,000 cycles with load
 OPERATING FORCE: 200 ± 100 gf (1.96 ± 0.98N)
 TRAVEL: 4 ± 0.3 mm
 OPERATING TEMPERATURE: -20°C to 70°C

Materials

KNOB: POM
 FRAME: SPCC
 CONTACT: Silver clad
 TERMINAL: Silver plated



Dimensions are shown: mm
 Specifications and dimensions subject to change

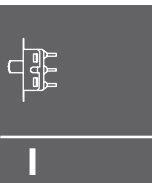

Side

SS Series Miniature Slide Switches

SS-22H16-G DPDT NON-SHORTING

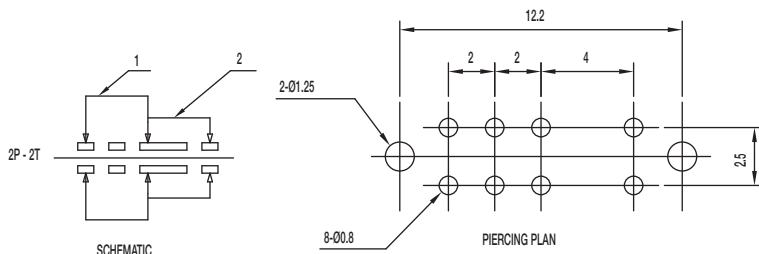
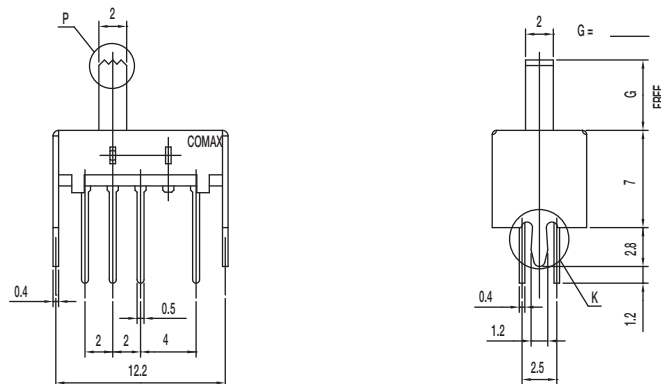
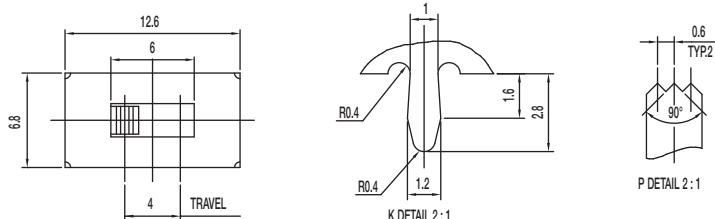

Specifications

CONTACT RATING: 0.3A @ 30 VDC
 INITIAL CONTACT RESISTANCE: 30 m ohms max.
 INSULATION RESISTANCE: 100 M ohms min.
 DIELECTRIC STRENGTH: 500 V AC (50-60 Hz) between open terminals and between the frame and terminal.
 OPERATING LIFE: 10,000 cycles with load
 OPERATING FORCE: 200 ± 100 gf (1.96 ± 0.98N)
 TRAVEL: 4 ± 0.3 mm
 OPERATING TEMPERATURE: -20°C to 70°C

Materials

KNOB: POM
 FRAME: SPCC
 CONTACT: Silver clad
 TERMINAL: Silver plated

SS-23D04-VG 2P3T NON-SHORTING

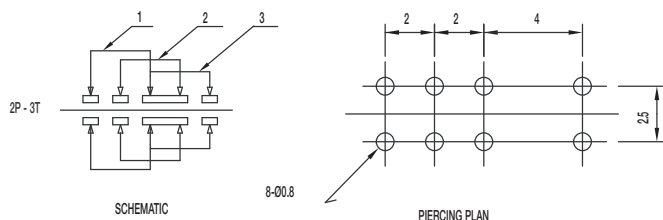
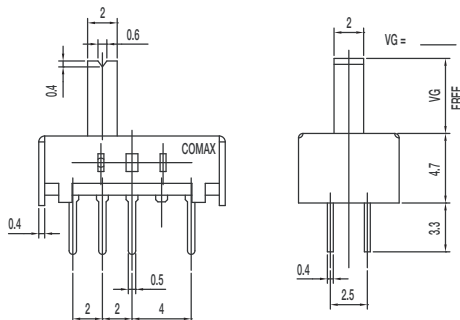
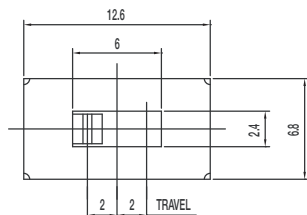

Specifications

CONTACT RATING: 0.3A @ 30 VDC
 INITIAL CONTACT RESISTANCE: 30 m ohms max.
 INSULATION RESISTANCE: 100 M ohms min.
 DIELECTRIC STRENGTH: 500 V AC (50-60 Hz) between open terminals and between the frame and terminal.
 OPERATING LIFE: 10,000 cycles with load
 OPERATING FORCE: 150 ± 50 gf (1.47 ± 0.49N)
 200 ± 100 gf (1.96 ± 0.98N)
 TRAVEL: 2 ± 0.3 mm
 OPERATING TEMPERATURE: -20°C to 70°C

Materials

KNOB: POM
 FRAME: SPCC
 CONTACT: Silver clad
 TERMINAL: Silver plated

Dimensions are shown: mm
 Specifications and dimensions subject to change



Slide



SS Series Miniature Slide Switches

SS-23D07-G PA 2P3T NON-SHORTING

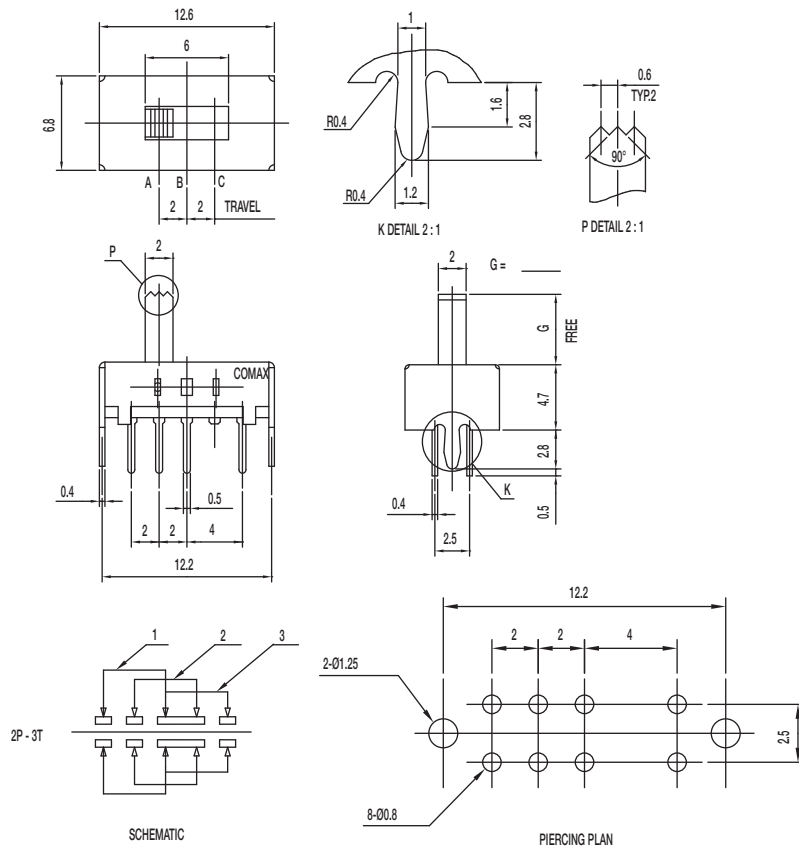

Specifications

CONTACT RATING: 0.3A @ 30 VDC
 INITIAL CONTACT RESISTANCE: 30 m ohms max.
 INSULATION RESISTANCE: 100 M ohms min.
 DIELECTRIC STRENGTH: 500 V AC (50-60 Hz) between open terminals and between the frame and terminal.
 OPERATING LIFE: 10,000 cycles with load
 OPERATING FORCE: 250 ± 150 gf (2.45 ± 1.47N)
 300 ± 150 gf (2.94 ± 1.47N)
 TRAVEL: 2 ± 0.3 mm
 OPERATING TEMPERATURE: -20°C to 80°C

Materials

KNOB: PA
 FRAME: SPCC
 CONTACT: Silver clad
 TERMINAL: Silver plated

SS-23D08-G 2P3T

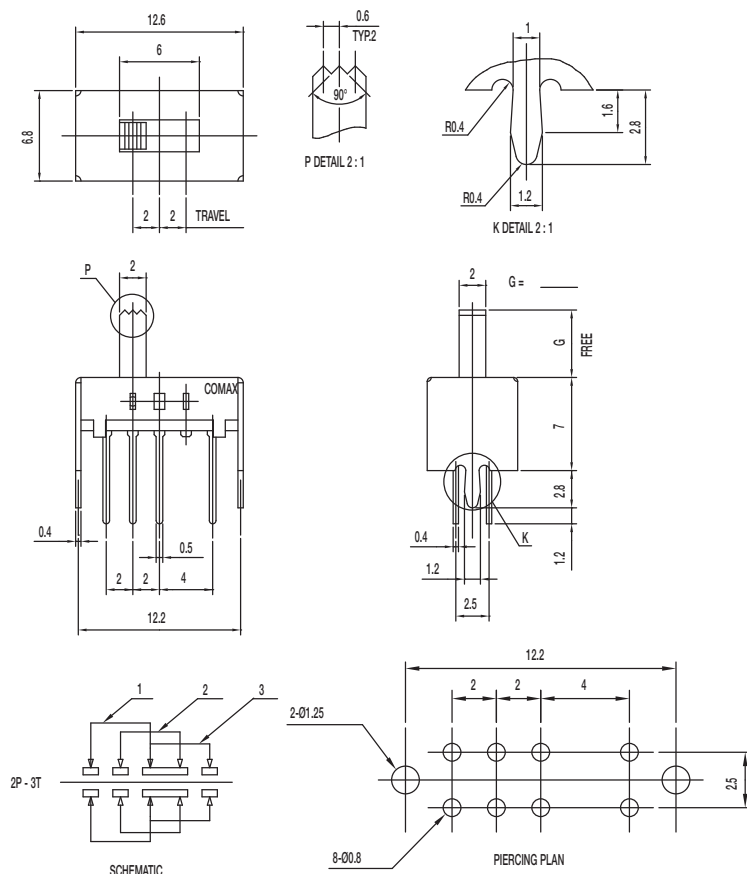

Specifications

CONTACT RATING: 0.3A @ 30 VDC
 INITIAL CONTACT RESISTANCE: 30 m ohms max.
 INSULATION RESISTANCE: 100 M ohms min.
 DIELECTRIC STRENGTH: 500 V AC (50-60 Hz) between open terminals and between the frame and terminal.
 OPERATING LIFE: 10,000 cycles with load
 OPERATING FORCE: 150 ± 50 gf (1.47 ± 0.49N)
 200 ± 100 gf (1.96 ± 0.98N)
 TRAVEL: 2 ± 0.3 mm
 OPERATING TEMPERATURE: -20°C to 70°C

Materials

KNOB: POM
 FRAME: SPCC
 CONTACT: Silver clad
 TERMINAL: Silver plated



Dimensions are shown: mm
 Specifications and dimensions subject to change

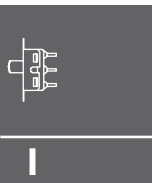

Side

SS Series Miniature Slide Switches

SS-24D02-VG 2P4T

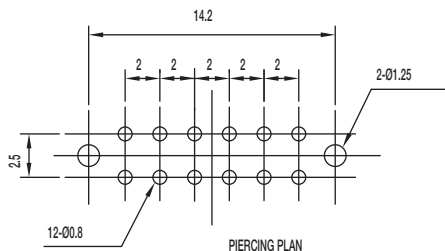
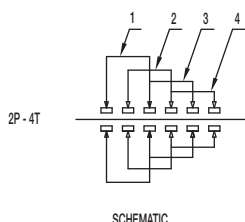
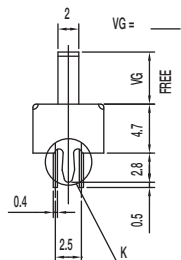
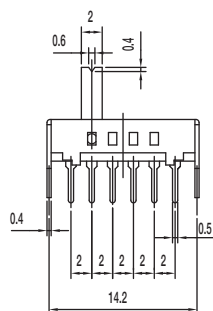
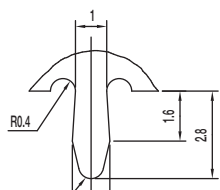
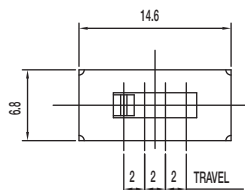

Specifications

CONTACT RATING: 0.3A @ 30 VDC
 INITIAL CONTACT RESISTANCE: 30 m ohms max.
 INSULATION RESISTANCE: 100 M ohms min.
 DIELECTRIC STRENGTH: 500 V AC (50-60 Hz) between open terminals and between the frame and terminal.
 OPERATING LIFE: 10,000 cycles with load
 OPERATING FORCE: 250 ± 100 gf (2.45 ± 0.98N)
 TRAVEL: 2 ± 0.3 mm
 OPERATING TEMPERATURE: -20°C to 70°C

Materials

KNOB: POM
 FRAME: SPCC
 CONTACT: Silver clad
 TERMINAL: Silver plated

SS-24D04-VG PA 2P4T

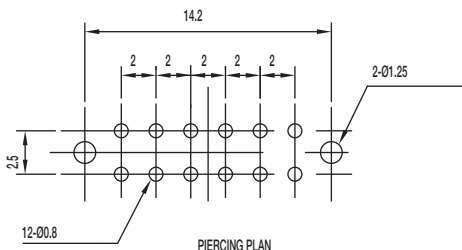
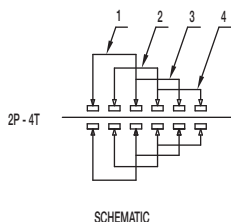
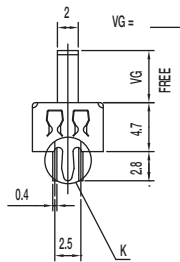
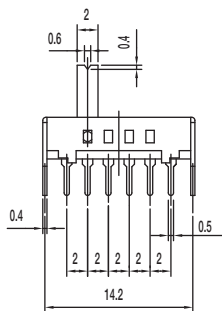
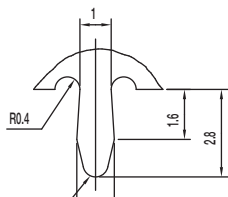
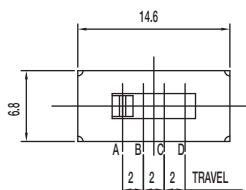

Specifications

CONTACT RATING: 0.3A @ 30 VDC
 INITIAL CONTACT RESISTANCE: 30 m ohms max.
 INSULATION RESISTANCE: 100 M ohms min.
 DIELECTRIC STRENGTH: 500 V AC (50-60 Hz) between open terminals and between the frame and terminal.
 OPERATING LIFE: 10,000 cycles with load
 OPERATING FORCE: 250 ± 100 gf (2.45 ± 0.98N)
 TRAVEL: 2 ± 0.3 mm
 OPERATING TEMPERATURE: -20°C to 70°C

Materials

KNOB: PA
 FRAME: SPCC
 CONTACT: Silver clad
 TERMINAL: Silver plated

SS Series Miniature Slide Switches

SS-24D07-VG PA 2P4T

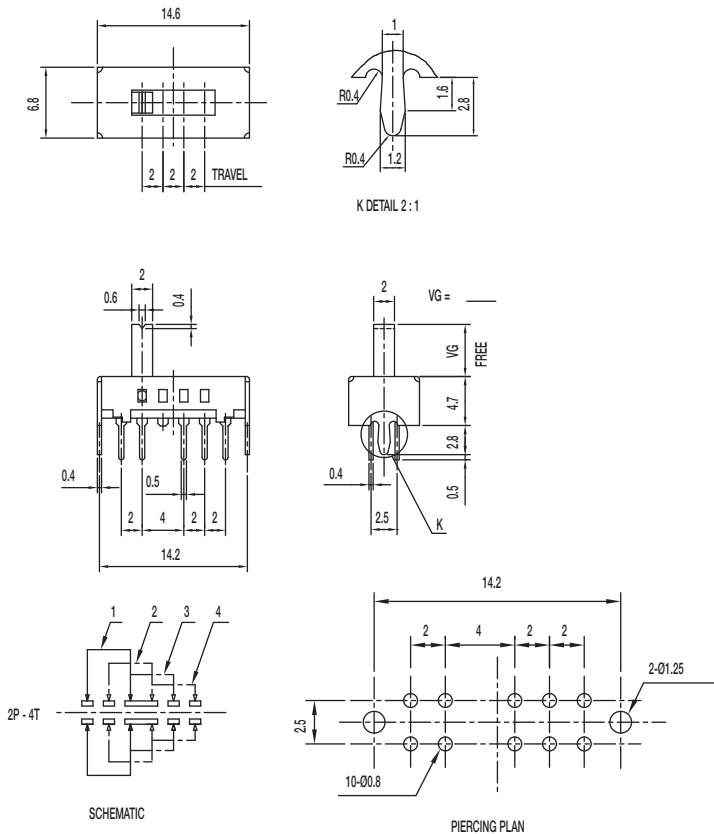

Specifications

CONTACT RATING: 0.3A @ 30 VDC
 INITIAL CONTACT RESISTANCE: 30 m ohms max.
 INSULATION RESISTANCE: 100 M ohms min.
 DIELECTRIC STRENGTH: 500 V AC (50-60 Hz) between open terminals and between the frame and terminal.
 OPERATING LIFE: 10,000 cycles with load
 OPERATING FORCE: 250 ± 100 gf (2.45 ± 0.98N)
 TRAVEL: 2 ± 0.3 mm
 OPERATING TEMPERATURE: -20°C to 70°C

Materials

KNOB: PA
 FRAME: SPCC
 CONTACT: Silver clad
 TERMINAL: Silver plated

SS-42D07-VG NS 4P2T NON-SHORTING

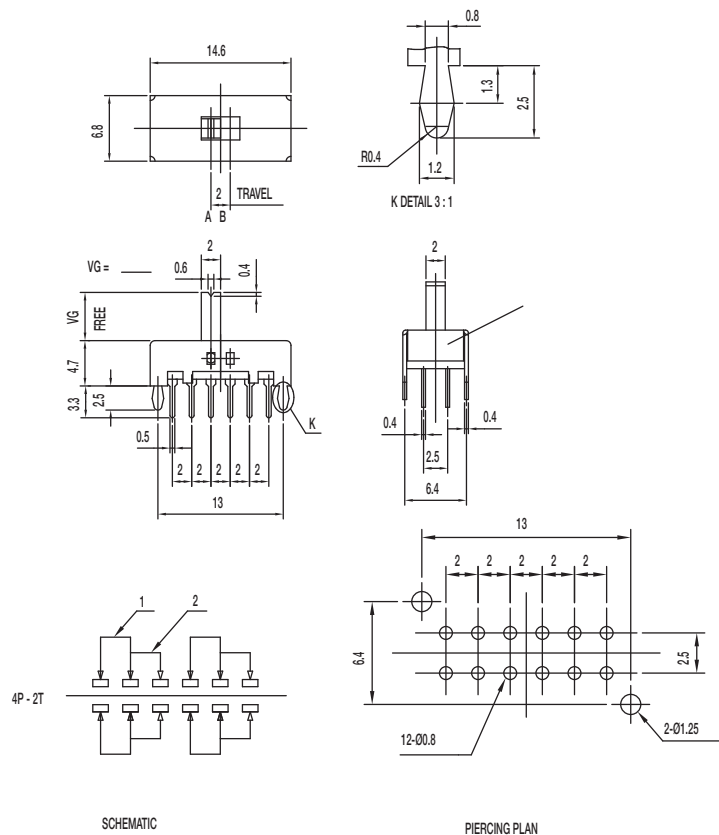

Specifications

CONTACT RATING: 0.3A @ 30 VDC
 INITIAL CONTACT RESISTANCE: 30 m ohms max.
 INSULATION RESISTANCE: 100 M ohms min.
 DIELECTRIC STRENGTH: 500 V AC (50-60 Hz) between open terminals and between the frame and terminal.
 OPERATING LIFE: 10,000 cycles with load
 OPERATING FORCE: 250 ± 100 gf (2.45 ± 0.98N)
 TRAVEL: 2 ± 0.3 mm
 OPERATING TEMPERATURE: -20°C to 70°C

Materials

KNOB: POM
 FRAME: SPCC
 CONTACT: Silver clad
 TERMINAL: Silver plated



Dimensions are shown: mm
 Specifications and dimensions subject to change

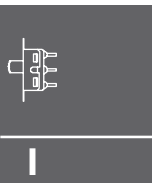

Side

SS Series Miniature Slide Switches

SS-13E08-DG 1P3T

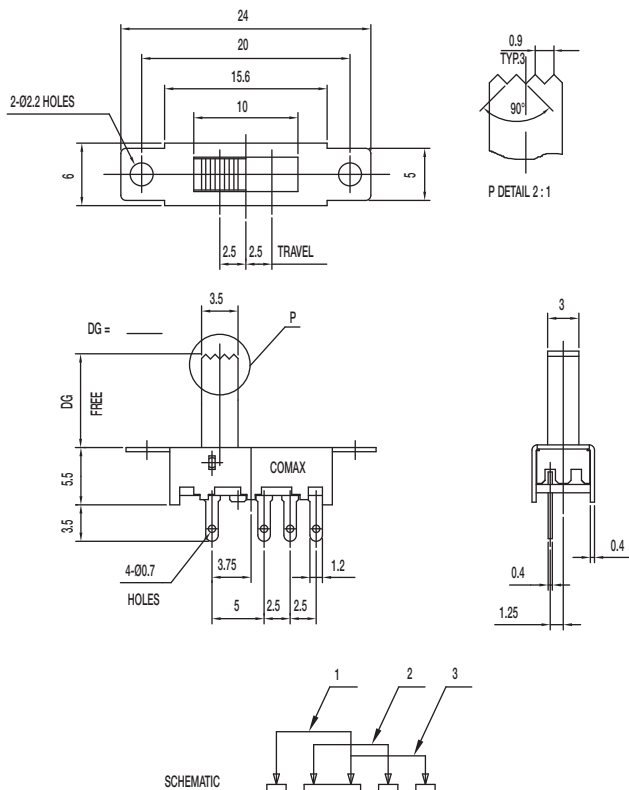

Specifications

CONTACT RATING: 0.3A @ 30 VDC
 INITIAL CONTACT RESISTANCE: 30 m ohms max.
 INSULATION RESISTANCE: 100 M ohms min.
 DIELECTRIC STRENGTH: 500 V AC (50-60 Hz) between open terminals and between the frame and terminal.
 OPERATING LIFE: 10,000 cycles with load
 OPERATING FORCE: 200 ± 100 gf (1.96 ± 0.98N)
 250 ± 100 gf (2.45 ± 0.98N)
 TRAVEL: 2.5 ± 0.3 mm
 OPERATING TEMPERATURE: -20°C to 70°C

Materials

KNOB: POM
 FRAME: SPCC
 CONTACT: Silver clad
 TERMINAL: Silver plated

SS-13E29-TG 1P3T

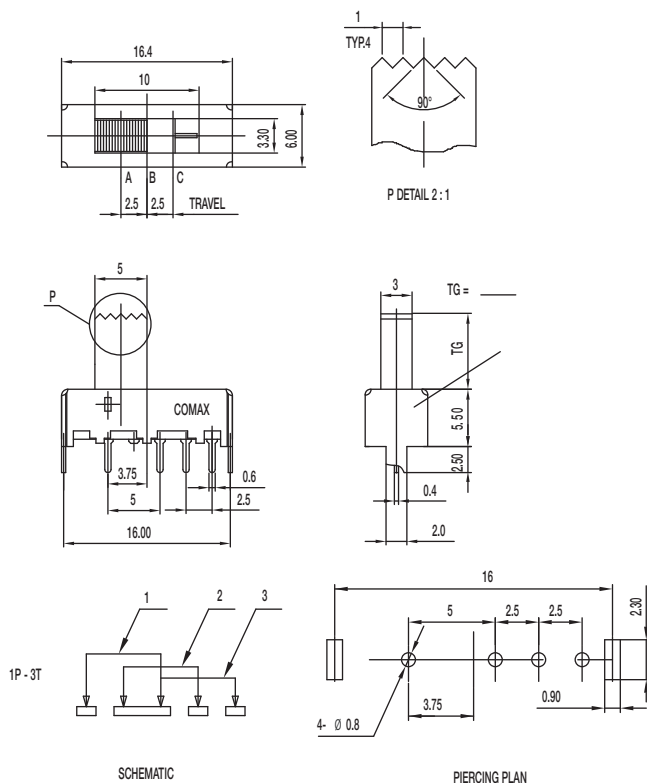

Specifications

CONTACT RATING: 0.3A @ 30 VDC
 INITIAL CONTACT RESISTANCE: 30 m ohms max.
 INSULATION RESISTANCE: 100 M ohms min.
 DIELECTRIC STRENGTH: 500 V AC (50-60 Hz) between open terminals and between the frame and terminal.
 OPERATING LIFE: 10,000 cycles with load
 OPERATING FORCE: 200 ± 100 gf (1.96 ± 0.98N)
 250 ± 100 gf (2.45 ± 0.98N)
 TRAVEL: 2.5 ± 0.3 mm
 OPERATING TEMPERATURE: -20°C to 70°C

Materials

KNOB: POM
 FRAME: SPCC
 CONTACT: Silver clad
 TERMINAL: Silver plated

SS Series Miniature Slide Switches

SS-22J08-G DPDT NON-SHORTING

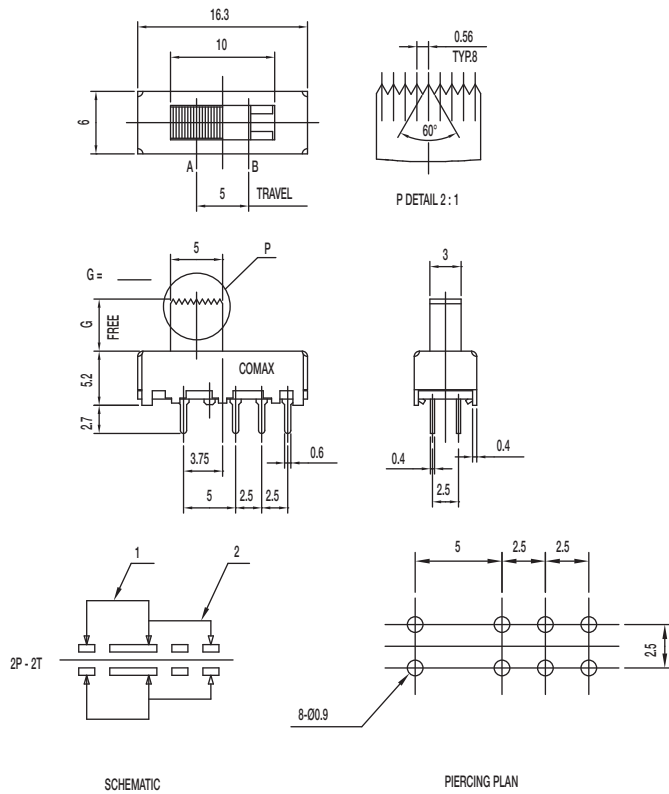

Specifications

CONTACT RATING: 0.3A @ 30 VDC
 INITIAL CONTACT RESISTANCE: 30 m ohms max.
 INSULATION RESISTANCE: 100 M ohms min.
 DIELECTRIC STRENGTH: 500 V AC (50-60 Hz) between open terminals and between the frame and terminal.
 OPERATING LIFE: 10,000 cycles with load
 OPERATING FORCE: 200 ± 100 gf (1.96 ± 0.98N)
 TRAVEL: 5 ± 0.3 mm
 OPERATING TEMPERATURE: -20°C to 70°C

Materials

KNOB: POM
 FRAME: SPCC
 CONTACT: Silver clad
 TERMINAL: Silver plated

SS-23E05-G 4 2P3T

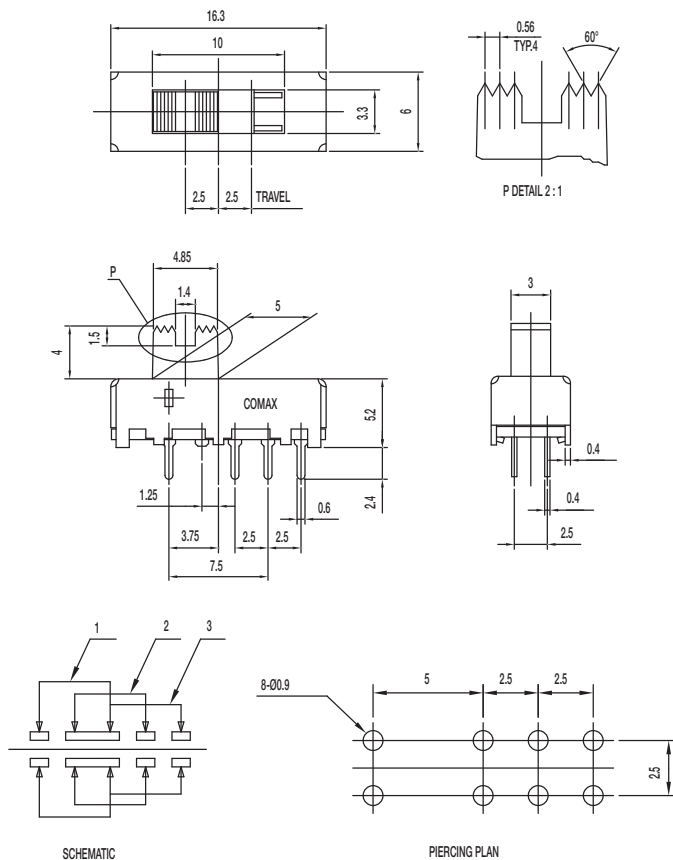

Specifications

CONTACT RATING: 0.3A @ 30 VDC
 INITIAL CONTACT RESISTANCE: 30 m ohms max.
 INSULATION RESISTANCE: 100 M ohms min.
 DIELECTRIC STRENGTH: 500 V AC (50-60 Hz) between open terminals and between the frame and terminal.
 OPERATING LIFE: 10,000 cycles with load
 OPERATING FORCE: 200 ± 100 gf (1.96 ± 0.98N)
 300 ± 100 gf (2.94 ± 0.98N)
 TRAVEL: 2.5 ± 0.3 mm
 OPERATING TEMPERATURE: -20°C to 70°C

Materials

KNOB: POM
 FRAME: SPCC
 CONTACT: Silver clad
 TERMINAL: Silver plated



Dimensions are shown: mm
 Specifications and dimensions subject to change

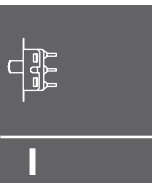

Side

SS Series Miniature Slide Switches

SS-23E06-G 2P3T

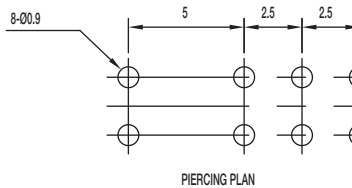
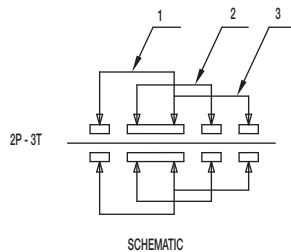
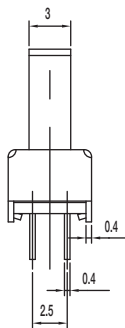
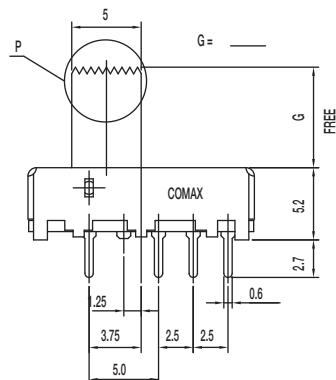
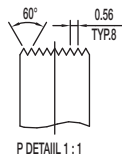
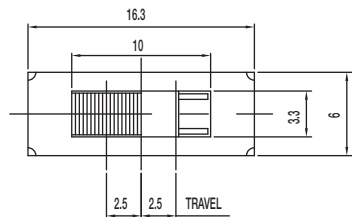

Specifications

CONTACT RATING: 0.3A @ 30 VDC
 INITIAL CONTACT RESISTANCE: 30 m ohms max.
 INSULATION RESISTANCE: 100 M ohms min.
 DIELECTRIC STRENGTH: 500 V AC (50-60 Hz) between open terminals and between the frame and terminal.
 OPERATING LIFE: 10,000 cycles with load
 OPERATING FORCE: 200 ± 100 gf (1.96 ± 0.98N)
 250 ± 100 gf (2.45 ± 0.98N)
 TRAVEL: 2.5 ± 0.3 mm
 OPERATING TEMPERATURE: -20°C to 70°C

Materials

KNOB: POM
 FRAME: SPCC
 CONTACT: Silver clad
 TERMINAL: Silver plated

SS-23E08-TG 2P3T

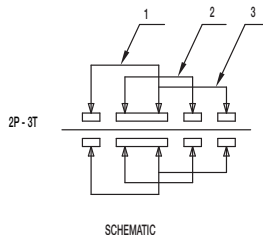
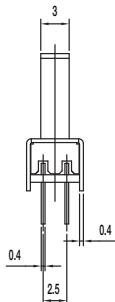
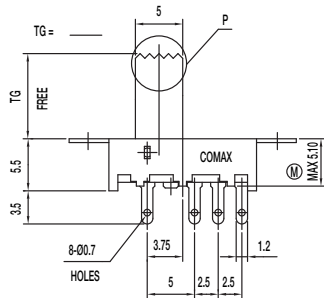
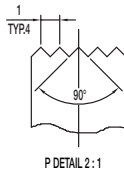
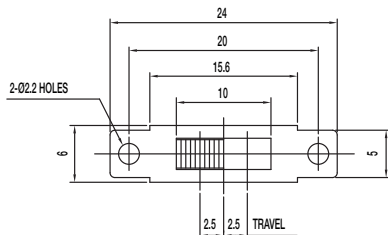

TG=6,8,9mm Max 5.10mm

Specifications

CONTACT RATING: 0.3A @ 30 VDC
 INITIAL CONTACT RESISTANCE: 30 m ohms max.
 INSULATION RESISTANCE: 100 M ohms min.
 DIELECTRIC STRENGTH: 500 V AC (50-60 Hz) between open terminals and between the frame and terminal.
 OPERATING LIFE: 10,000 cycles with load
 OPERATING FORCE: 200 ± 100 gf (1.96 ± 0.98N)
 250 ± 100 gf (2.45 ± 0.98N)
 TRAVEL: 2.5 ± 0.3 mm
 OPERATING TEMPERATURE: -20°C to 80°C

Materials

KNOB: POM
 FRAME: SPCC
 CONTACT: Silver clad
 TERMINAL: Silver plated

Dimensions are shown: mm
 Specifications and dimensions subject to change



Slide



SS Series Miniature Slide Switches

SS-23E10-G 2P3T

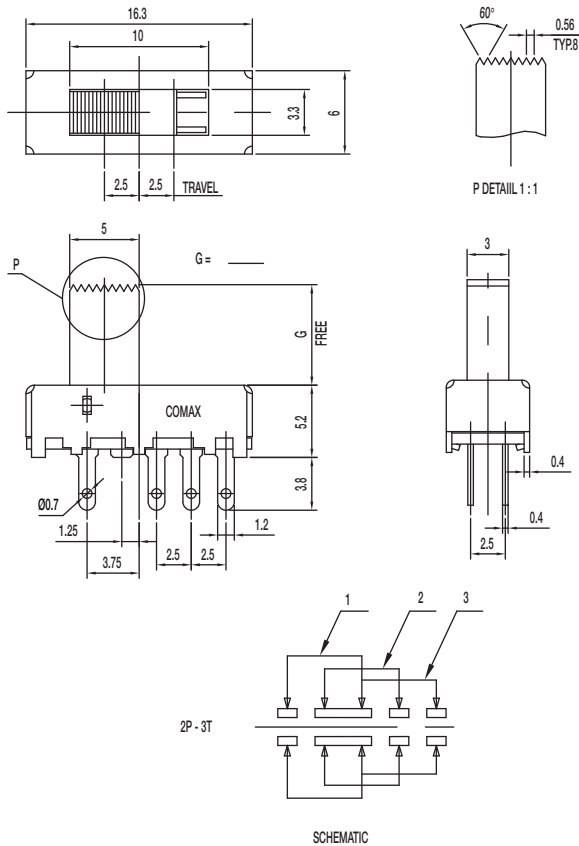

Specifications

CONTACT RATING: 0.3A @ 30 VDC
 INITIAL CONTACT RESISTANCE: 30 m ohms max.
 INSULATION RESISTANCE: 100 M ohms min.
 DIELECTRIC STRENGTH: 500 V AC (50-60 Hz) between open terminals and between the frame and terminal.
 OPERATING LIFE: 10,000 cycles with load
 OPERATING FORCE: 200 ± 100 gf (1.96 ± 0.98N)
 250 ± 100 gf (2.45 ± 0.98N)
 TRAVEL: 2.5 ± 0.3 mm
 OPERATING TEMPERATURE: -20°C to 70°C

Materials

KNOB: POM
 FRAME: SPCC
 CONTACT: Silver clad
 TERMINAL: Silver plated

SS-23E11-G 2P3T

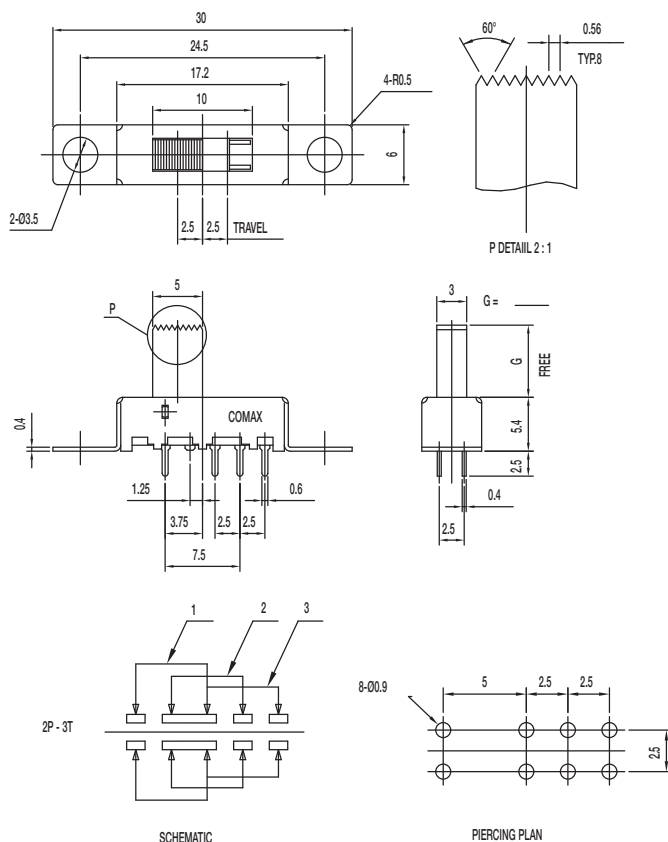

Specifications

CONTACT RATING: 0.3A @ 30 VDC
 INITIAL CONTACT RESISTANCE: 30 m ohms max.
 INSULATION RESISTANCE: 100 M ohms min.
 DIELECTRIC STRENGTH: 500 V AC (50-60 Hz) between open terminals and between the frame and terminal.
 OPERATING LIFE: 10,000 cycles with load
 OPERATING FORCE: 200 ± 100 gf (1.96 ± 0.98N)
 250 ± 100 gf (2.45 ± 0.98N)
 TRAVEL: 2.5 ± 0.3 mm
 OPERATING TEMPERATURE: -20°C to 70°C

Materials

KNOB: POM
 FRAME: SPCC
 CONTACT: Silver clad
 TERMINAL: Silver plated



Dimensions are shown: mm
 Specifications and dimensions subject to change

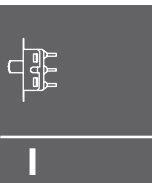

Slide

SS Series Miniature Slide Switches

SS-23E12-TG 2P3T

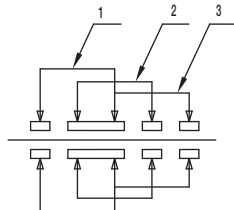
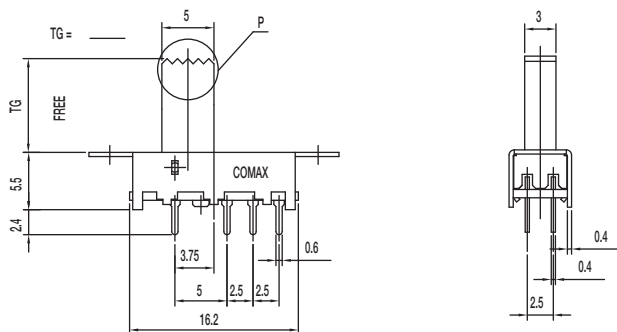
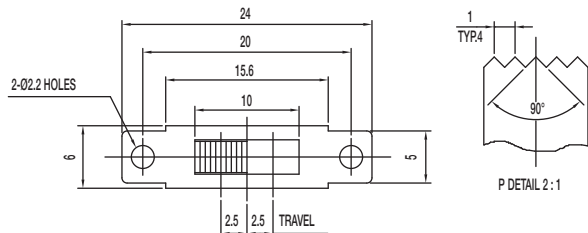

SCHEMATIC

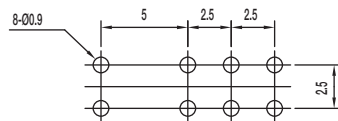

PIERCING PLAN

Specifications

CONTACT RATING: 0.3A @ 30 VDC
 INITIAL CONTACT RESISTANCE: 30 m ohms max.
 INSULATION RESISTANCE: 100 M ohms min.
 DIELECTRIC STRENGTH: 500 V AC (50-60 Hz) between open terminals and between the frame and terminal.
 OPERATING LIFE: 10,000 cycles with load
 OPERATING FORCE: 200 ± 100 gf (1.96 ± 0.98N)
 250 ± 100 gf (2.45 ± 0.98N)
 TRAVEL: 2.5 ± 0.3 mm
 OPERATING TEMPERATURE: -20°C to 70°C

Materials

KNOB: POM
 FRAME: SPCC
 CONTACT: Silver clad
 TERMINAL: Silver plated

SS-23E14-TG NS 2P3T NON-SHORTING

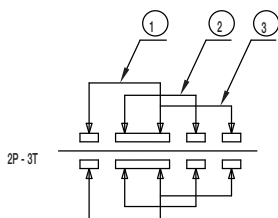
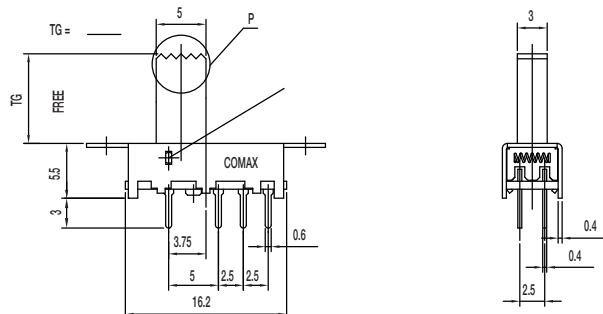
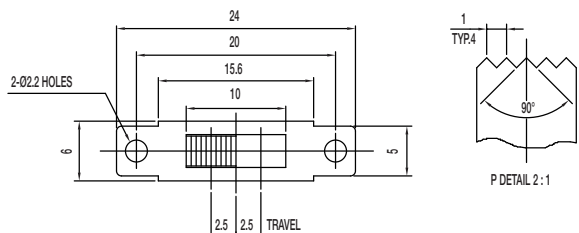

SCHEMATIC

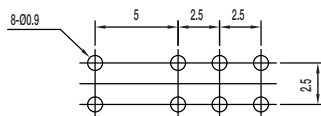

PIERCING PLAN

Specifications

CONTACT RATING: 0.3A @ 30 VDC
 INITIAL CONTACT RESISTANCE: 30 m ohms max.
 INSULATION RESISTANCE: 100 M ohms min.
 DIELECTRIC STRENGTH: 500 V AC (50-60 Hz) between open terminals and between the frame and terminal.
 OPERATING LIFE: 10,000 cycles with load
 OPERATING FORCE: 200 ± 100 gf (1.96 ± 0.98N)
 250 ± 100 gf (2.45 ± 0.98N)
 TRAVEL: 2.5 ± 0.3 mm
 OPERATING TEMPERATURE: -20°C to 70°C

Materials

KNOB: POM
 FRAME: SPCC
 CONTACT: Silver clad
 TERMINAL: Silver plated



Dimensions are shown: mm
 Specifications and dimensions subject to change

SS Series Miniature Slide Switches

SS-24E06-TG 2P4T SHORTING

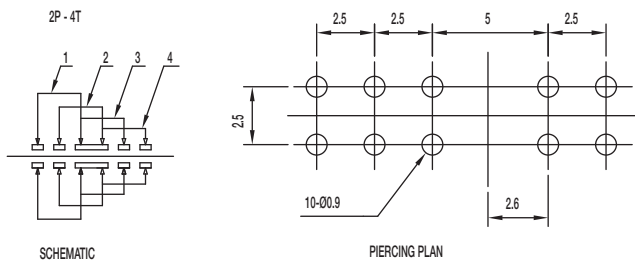
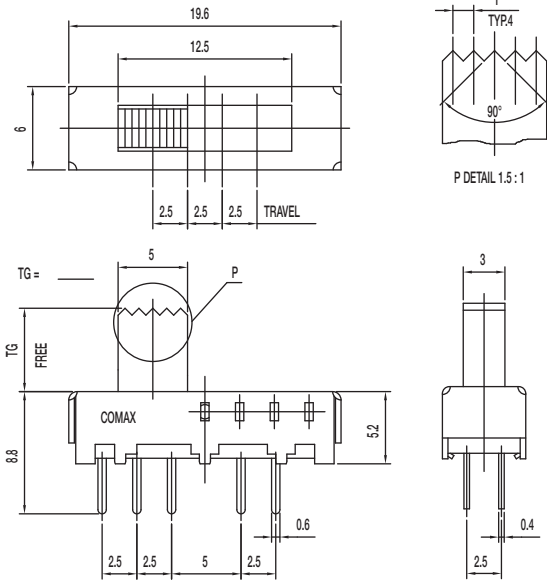

Specifications

CONTACT RATING: 0.3A @ 30 VDC
 INITIAL CONTACT RESISTANCE: 30 m ohms max.
 INSULATION RESISTANCE: 100 M ohms min.
 DIELECTRIC STRENGTH: 500 V AC (50-60 Hz) between open terminals and between the frame and terminal.
 OPERATING LIFE: 10,000 cycles with load
 OPERATING FORCE: 250 ± 100 gf (2.45 ± 0.98N)
 TRAVEL: 2.5 ± 0.3 mm
 OPERATING TEMPERATURE: -20°C to 70°C

Materials

KNOB: POM
 FRAME: SPCC
 CONTACT: Silver clad
 TERMINAL: Silver plated

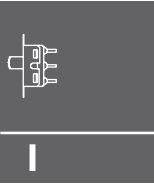

Side

SS-24E08-CG 2P4T

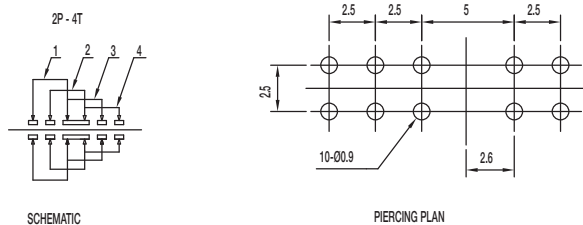
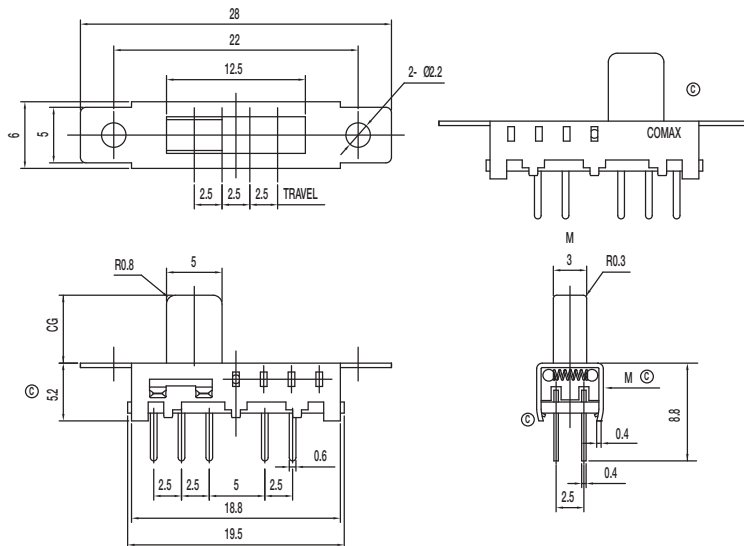

Specifications

CONTACT RATING: 0.3A @ 30 VDC
 INITIAL CONTACT RESISTANCE: 30 m ohms max.
 INSULATION RESISTANCE: 100 M ohms min.
 DIELECTRIC STRENGTH: 500 V AC (50-60 Hz) between open terminals and between the frame and terminal.
 OPERATING LIFE: 10,000 cycles with load
 OPERATING FORCE: 250 ± 100 gf (2.45 ± 0.98N)
 TRAVEL: 2.5 ± 0.3 mm
 OPERATING TEMPERATURE: -20°C to 70°C

Materials

KNOB: POM
 FRAME: SPCC
 CONTACT: Silver clad
 TERMINAL: Silver plated



Dimensions are shown: mm
 Specifications and dimensions subject to change

SS Series Miniature Slide Switches

SS-24E09-TG 2P4T

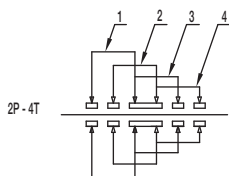
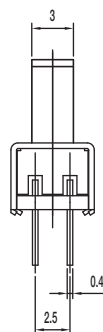
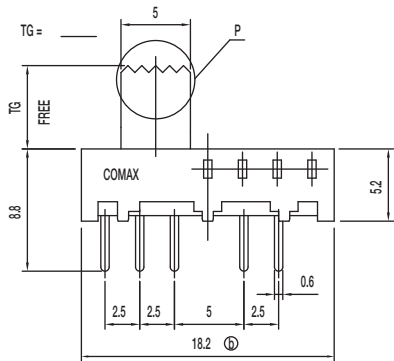
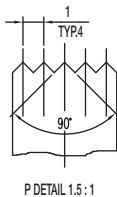
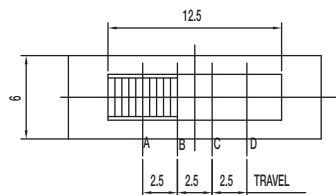

SCHEMATIC

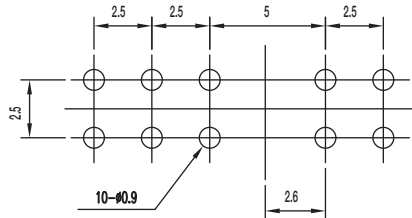

PIERCING PLAN

Specifications

- CONTACT RATING: 0.3A @ 30 VDC
- INITIAL CONTACT RESISTANCE: 30 m ohms max.
- INSULATION RESISTANCE: 100 M ohms min.
- DIELECTRIC STRENGTH: 500 V AC (50-60 Hz) between open terminals and between the frame and terminal.
- OPERATING LIFE: 10,000 cycles with load
- OPERATING FORCE: 250 ± 100 gf (2.45 ± 0.98N)
- TRAVEL: 2.5 ± 0.3 mm
- OPERATING TEMPERATURE: -20°C to 70°C

Materials

- KNOB: POM
- FRAME: SPCC
- CONTACT: Silver clad
- TERMINAL: Silver plated

SS-24E10-TG 2P4T

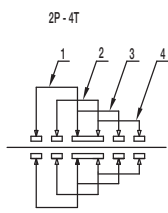
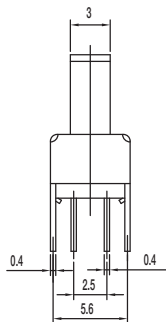
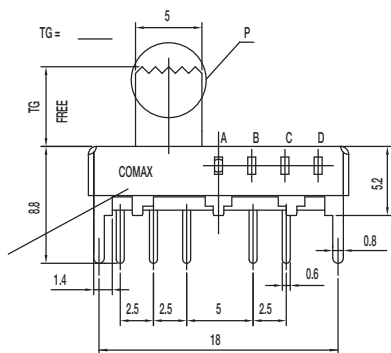
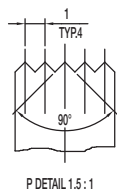
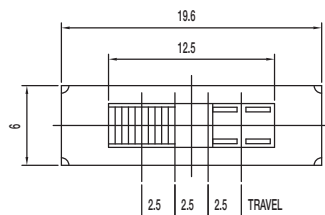

SCHEMATIC

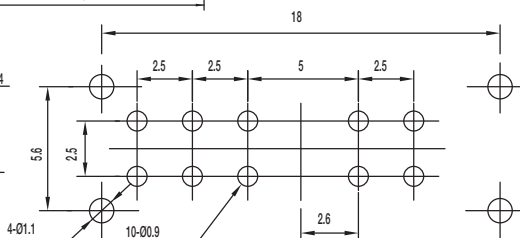

PIERCING PLAN

Specifications

- CONTACT RATING: 0.3A @ 30 VDC
- INITIAL CONTACT RESISTANCE: 30 m ohms max.
- INSULATION RESISTANCE: 100 M ohms min.
- DIELECTRIC STRENGTH: 500 V AC (50-60 Hz) between open terminals and between the frame and terminal.
- OPERATING LIFE: 10,000 cycles with load
- OPERATING FORCE: 250 ± 100 gf (2.45 ± 0.98N)
- TRAVEL: 2.5 ± 0.3 mm
- OPERATING TEMPERATURE: -20°C to 70°C

Materials

- KNOB: POM
- FRAME: SPCC
- CONTACT: Silver clad
- TERMINAL: Silver plated



Dimensions are shown: mm
Specifications and dimensions subject to change

SS Series Miniature Slide Switches

SS-24E18-CG 2P4T

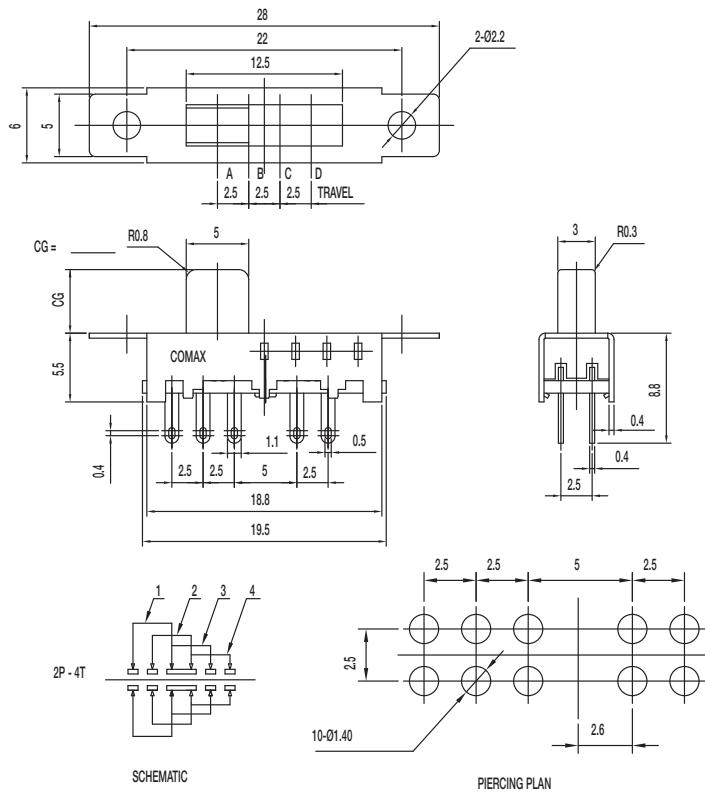

Specifications

CONTACT RATING: 0.3A @ 30 VDC
 INITIAL CONTACT RESISTANCE: 30 m ohms max.
 INSULATION RESISTANCE: 100 M ohms min.
 DIELECTRIC STRENGTH: 500 V AC (50-60 Hz) between open terminals and between the frame and terminal.
 OPERATING LIFE: 10,000 cycles with load
 OPERATING FORCE: 250 ± 100 gf (2.45 ± 0.98N)
 TRAVEL: 2.5 ± 0.3 mm
 OPERATING TEMPERATURE: -20°C to 70°C

Materials

KNOB: POM
 FRAME: SPCC
 CONTACT: Silver clad
 TERMINAL: Silver plated

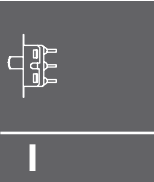

Side

SS-24E19-TG 2P4T

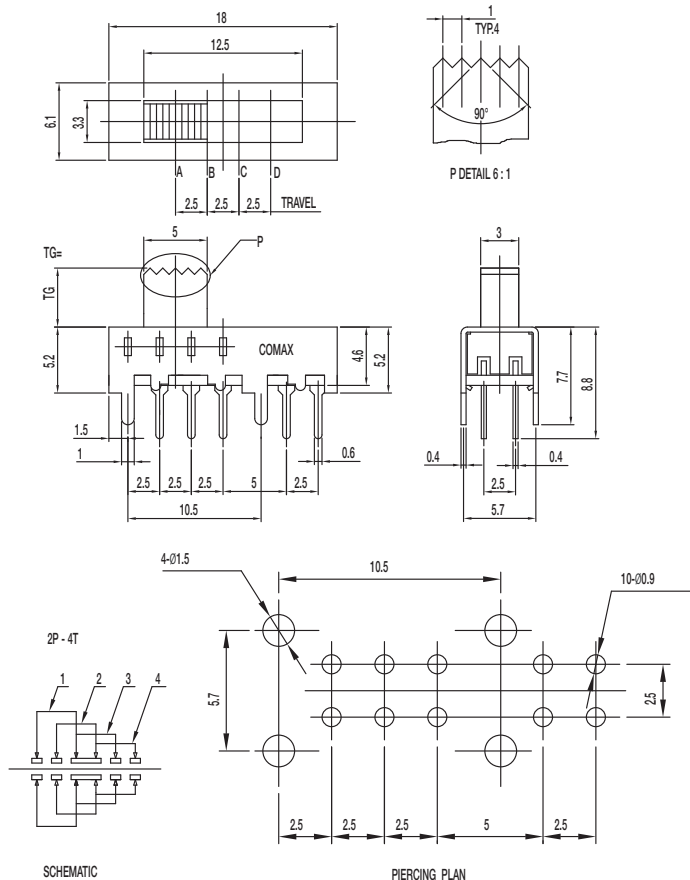

Specifications

CONTACT RATING: 0.3A @ 30 VDC
 INITIAL CONTACT RESISTANCE: 30 m ohms max.
 INSULATION RESISTANCE: 100 M ohms min.
 DIELECTRIC STRENGTH: 500 V AC (50-60 Hz) between open terminals and between the frame and terminal.
 OPERATING LIFE: 10,000 cycles with load
 OPERATING FORCE: 250 ± 100 gf (2.45 ± 0.98N)
 TRAVEL: 2.5 ± 0.3 mm
 OPERATING TEMPERATURE: -10°C to 60°C

Materials

KNOB: POM
 FRAME: SPCC
 CONTACT: Silver clad
 TERMINAL: Silver plated



Dimensions are shown: mm
 Specifications and dimensions subject to change

SS Series Miniature Slide Switches

SS-22H18-G DPDT NON-SHORTING

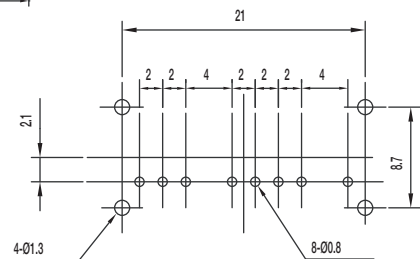
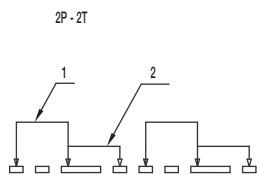
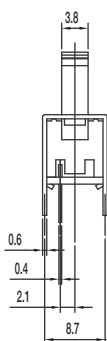
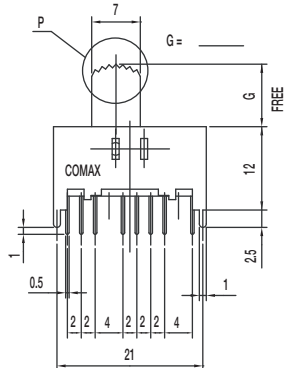
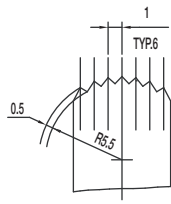
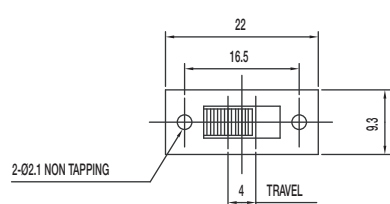

SCHEMATIC

PIERCING PLAN

Specifications

- CONTACT RATING: 0.3A @ 30 VDC
- INITIAL CONTACT RESISTANCE: 30 m ohms max.
- INSULATION RESISTANCE: 100 M ohms min.
- DIELECTRIC STRENGTH: 500 V AC (50-60 Hz) between open terminals and between the frame and terminal.
- OPERATING LIFE: 10,000 cycles with load
- OPERATING FORCE: 200 ± 100 gf (1.96 ± 0.98N)
- TRAVEL: 4 ± 0.3 mm
- OPERATING TEMPERATURE: -10°C to 60°C

Materials

- KNOB: POM
- FRAME: SPCC
- CONTACT: Silver clad
- TERMINAL: Silver plated

SS-23D10-G 2P3T

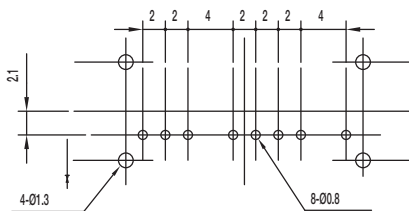
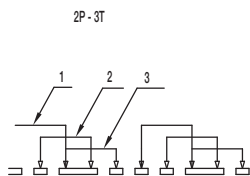
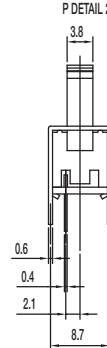
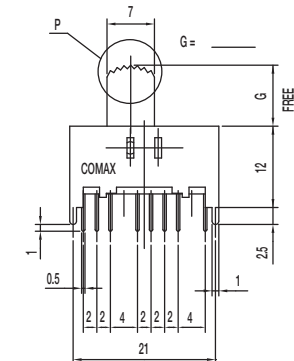
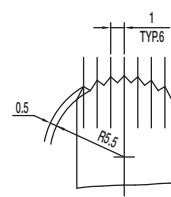
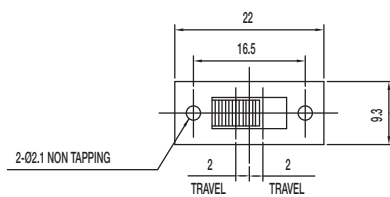

SCHEMATIC

PIERCING PLAN

Specifications

- CONTACT RATING: 0.3A @ 30 VDC
- INITIAL CONTACT RESISTANCE: 30 m ohms max.
- INSULATION RESISTANCE: 100 M ohms min.
- DIELECTRIC STRENGTH: 500 V AC (50-60 Hz) between open terminals and between the frame and terminal.
- OPERATING LIFE: 10,000 cycles with load
- OPERATING FORCE: 200 ± 100 gf (1.96 ± 0.98N)
300 ± 150 gf (2.94 ± 1.47N)
- TRAVEL: 2 ± 0.3 mm
- OPERATING TEMPERATURE: -20°C to 70°C

Materials

- KNOB: POM
- FRAME: SPCC
- CONTACT: Silver clad
- TERMINAL: Silver plated



Dimensions are shown: mm
Specifications and dimensions subject to change

Slide



SS Series Miniature Slide Switches

SS-24D01-M 2P4T

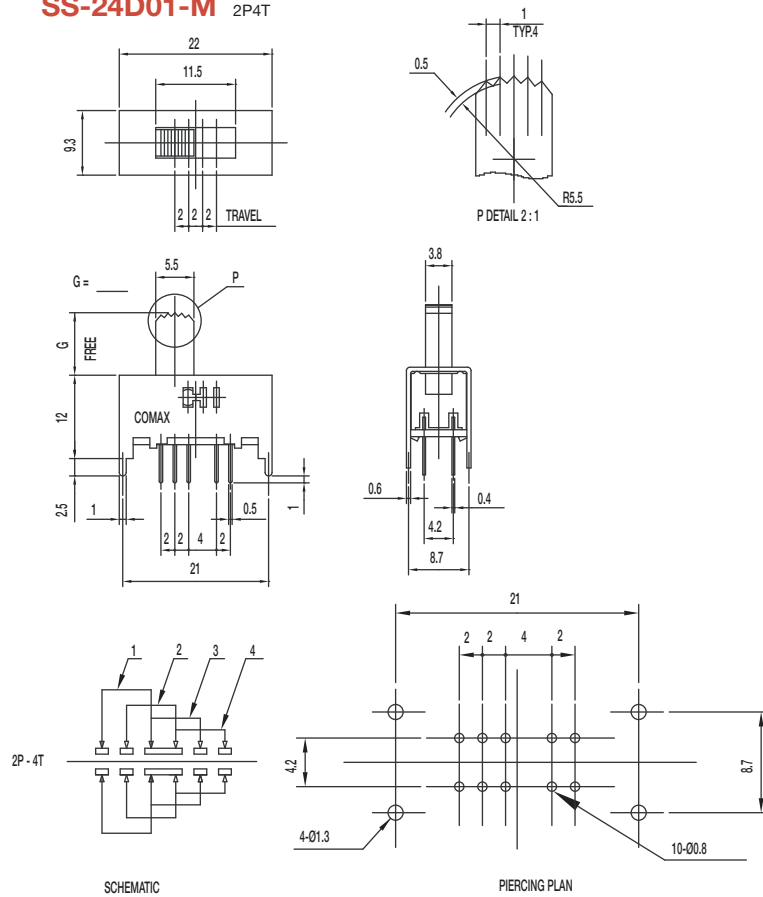

Specifications

CONTACT RATING: 0.3A @ 30 VDC
 INITIAL CONTACT RESISTANCE: 30 m ohms max.
 INSULATION RESISTANCE: 100 M ohms min.
 DIELECTRIC STRENGTH: 500 V AC (50-60 Hz) between open terminals and between the frame and terminal.
 OPERATING LIFE: 10,000 cycles with load
 OPERATING FORCE: 200 ± 100 gf (1.96 ± 0.98N)
 300 ± 100 gf (2.94 ± 0.98N); 450 ± 150 gf (4.41 ± 1.47N)
 TRAVEL: 2 ± 0.3 mm
 OPERATING TEMPERATURE: -20°C to 70°C

Materials

KNOB: POM
 FRAME: SPCC
 CONTACT: Silver clad
 TERMINAL: Silver plated

SS-42D11-G 4P2T SHORTING

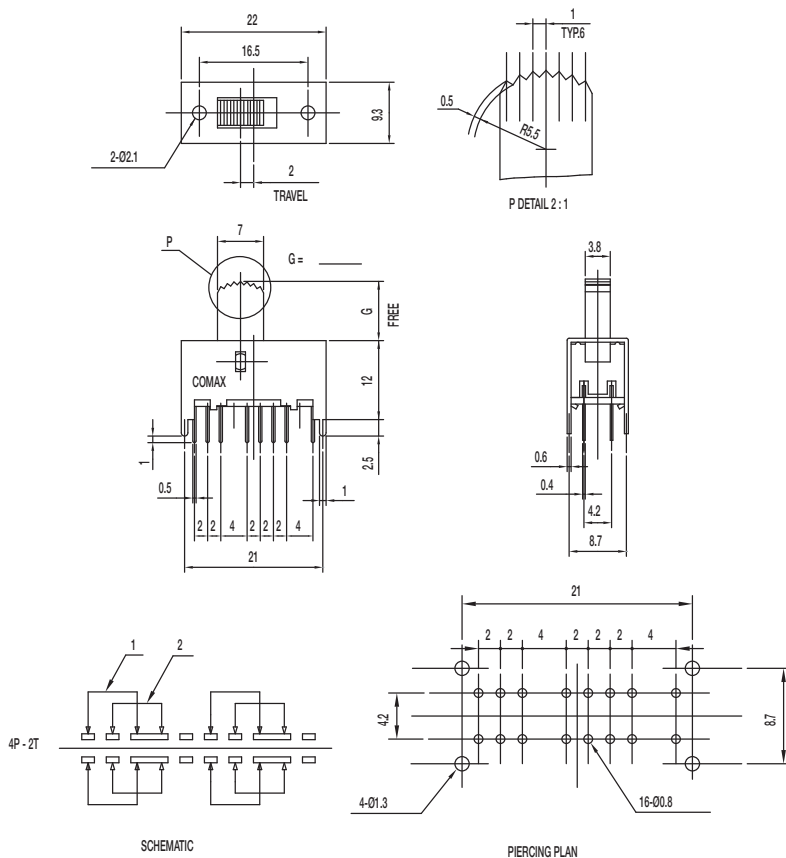

Specifications

CONTACT RATING: 0.3A @ 30 VDC
 INITIAL CONTACT RESISTANCE: 30 m ohms max.
 INSULATION RESISTANCE: 100 M ohms min.
 DIELECTRIC STRENGTH: 500 V AC (50-60 Hz) between open terminals and between the frame and terminal.
 OPERATING LIFE: 10,000 cycles with load
 OPERATING FORCE: 200 ± 100 gf (1.96 ± 0.98N)
 TRAVEL: 2 ± 0.3 mm
 OPERATING TEMPERATURE: -20°C to 70°C

Materials

KNOB: POM
 FRAME: SPCC
 CONTACT: Silver clad
 TERMINAL: Silver plated

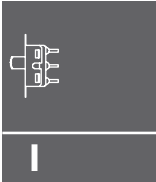

Side



Dimensions are shown: mm
 Specifications and dimensions subject to change

SS Series Miniature Slide Switches

SS-42H06-G 4P2T NON-SHORTING

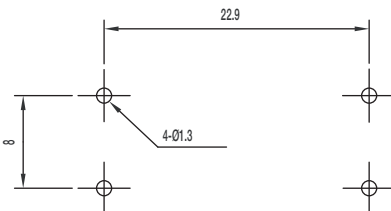
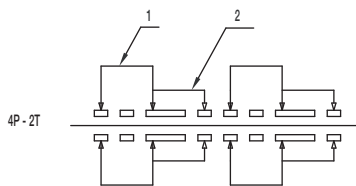
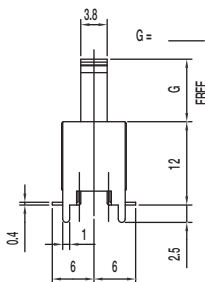
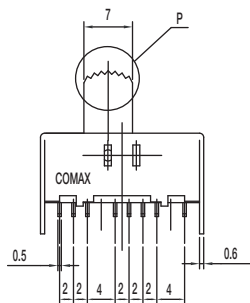
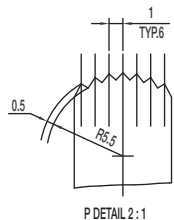
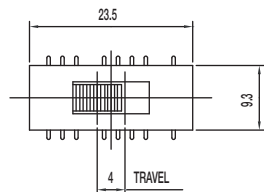

SCHEMATIC

PIERCING PLAN

SS-43D01-G 4P3T

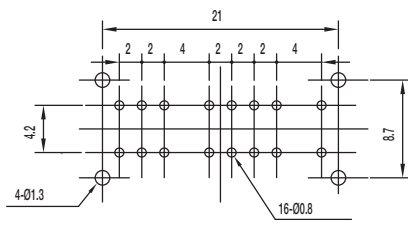
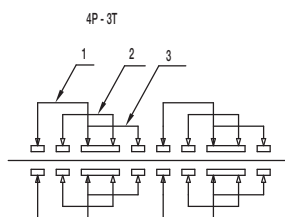
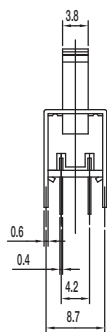
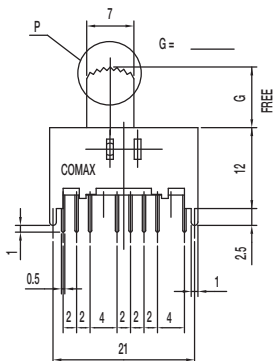
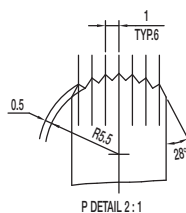
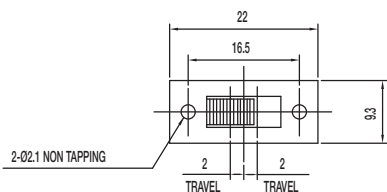

SCHEMATIC

PIERCING PLAN

Specifications

- CONTACT RATING: 0.3A @ 30 VDC
- INITIAL CONTACT RESISTANCE: 30 m ohms max.
- INSULATION RESISTANCE: 100 M ohms min.
- DIELECTRIC STRENGTH: 500 V AC (50-60 Hz) between open terminals and between the frame and terminal.
- OPERATING LIFE: 10,000 cycles with load
- OPERATING FORCE: 200 ± 100 gf (1.96 ± 0.98N)
- TRAVEL: 4 ± 0.3 mm
- OPERATING TEMPERATURE: -20°C to 70°C

Materials

- KNOB: POM
- FRAME: SPCC
- CONTACT: Silver clad
- TERMINAL: Silver plated

Specifications

- CONTACT RATING: 0.3A @ 30 VDC
- INITIAL CONTACT RESISTANCE: 30 m ohms max.
- INSULATION RESISTANCE: 100 M ohms min.
- DIELECTRIC STRENGTH: 500 V AC (50-60 Hz) between open terminals and between the frame and terminal.
- OPERATING LIFE: 10,000 cycles with load
- OPERATING FORCE: 200 ± 100 gf (1.96 ± 0.98N)
300 ± 150 gf (2.94 ± 1.47N)
- TRAVEL: 2 ± 0.3 mm
- OPERATING TEMPERATURE: -20°C to 70°C

Materials

- KNOB: POM
- FRAME: SPCC
- CONTACT: Silver clad
- TERMINAL: Silver plated

Dimensions are shown: mm
Specifications and dimensions subject to change

SS Series Miniature Slide Switches

SS-43D02-G 4P3T

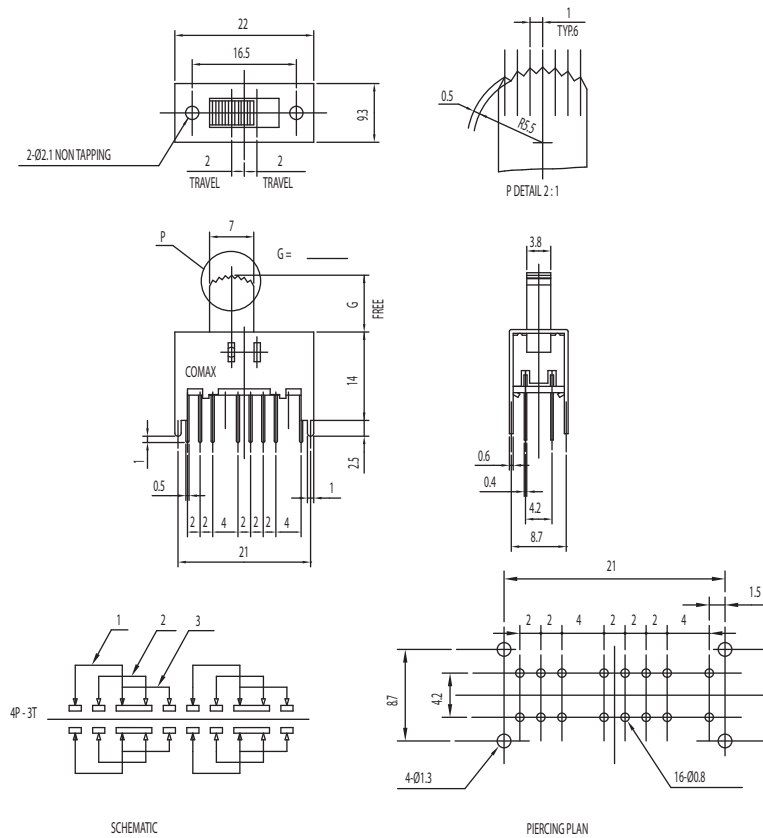

Specifications

CONTACT RATING: 0.3A @ 30 VDC
 INITIAL CONTACT RESISTANCE: 30 m ohms max.
 INSULATION RESISTANCE: 100 M ohms min.
 DIELECTRIC STRENGTH: 500 V AC (50-60 Hz) between open terminals and between the frame and terminal.
 OPERATING LIFE: 10,000 cycles with load
 OPERATING FORCE: 200 ± 100 gf (1.96 ± 0.98N)
 300 ± 150 gf (2.94 ± 1.47N)
 TRAVEL: 2 ± 0.3 mm
 OPERATING TEMPERATURE: -20°C to 70°C

Materials

KNOB: POM
 FRAME: SPCC
 CONTACT: Silver clad
 TERMINAL: Silver plated

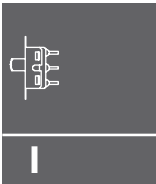

Side

SS-43D03-G 4P3T

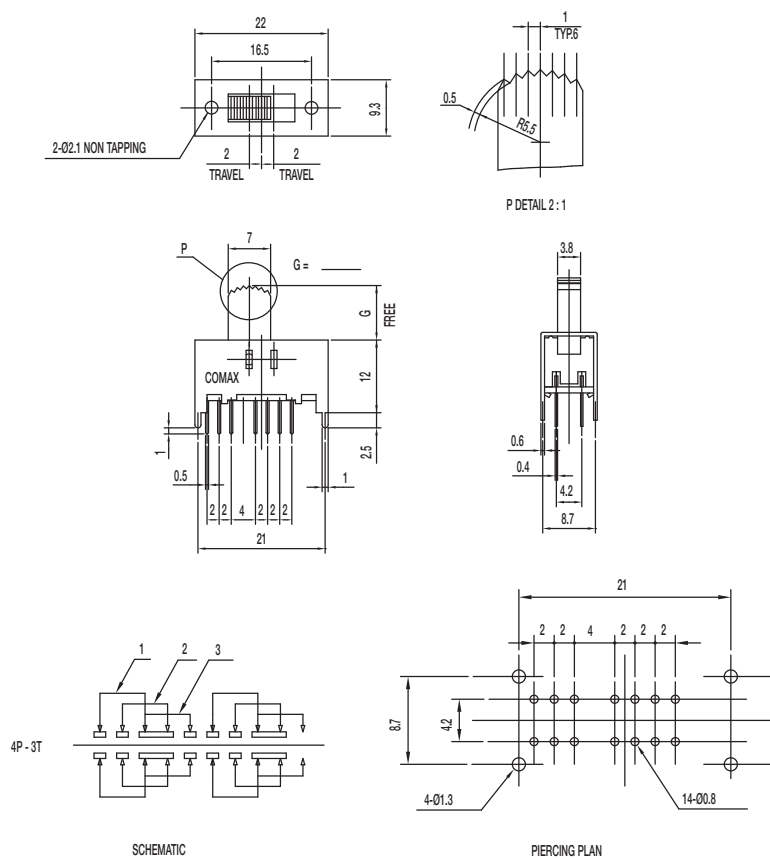

Specifications

CONTACT RATING: 0.3A @ 30 VDC
 INITIAL CONTACT RESISTANCE: 30 m ohms max.
 INSULATION RESISTANCE: 100 M ohms min.
 DIELECTRIC STRENGTH: 500 V AC (50-60 Hz) between open terminals and between the frame and terminal.
 OPERATING LIFE: 10,000 cycles with load
 OPERATING FORCE: 200 ± 100 gf (1.96 ± 0.98N)
 300 ± 150 gf (2.94 ± 1.47N)
 TRAVEL: 2 ± 0.3 mm
 OPERATING TEMPERATURE: -20°C to 70°C

Materials

KNOB: POM
 FRAME: SPCC
 CONTACT: Silver clad
 TERMINAL: Silver plated



Dimensions are shown: mm
 Specifications and dimensions subject to change

SS Series Miniature Slide Switches

SS-43D06-G 4P3T

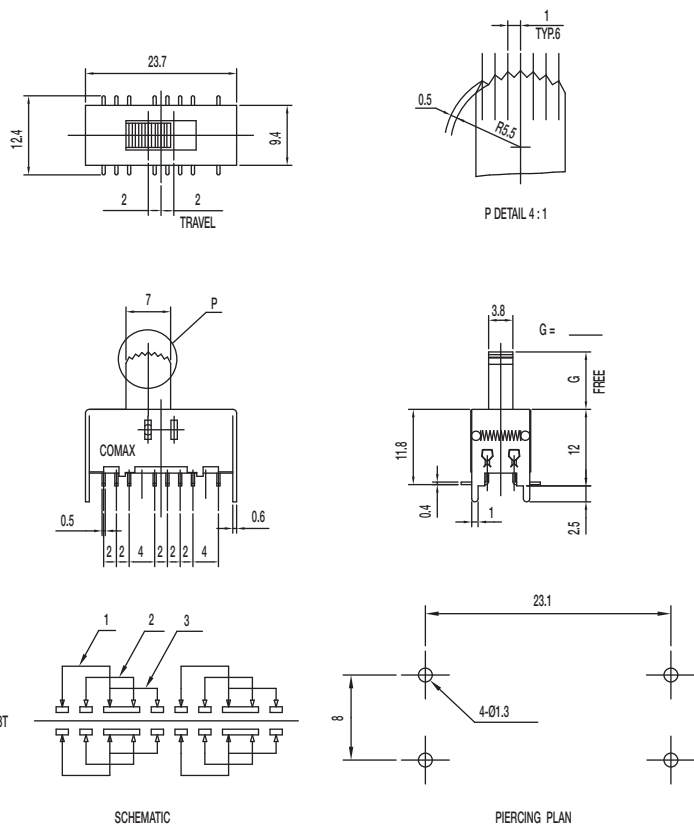

Specifications

CONTACT RATING: 0.3A @ 30 VDC
 INITIAL CONTACT RESISTANCE: 30 m ohms max.
 INSULATION RESISTANCE: 100 M ohms min.
 DIELECTRIC STRENGTH: 500 V AC (50-60 Hz) between open terminals and between the frame and terminal.
 OPERATING LIFE: 10,000 cycles with load
 OPERATING FORCE: 200 ± 100 gf (1.96 ± 0.98N)
 350 ± 150 gf (3.43 ± 1.47N)
 TRAVEL: 2 ± 0.3 mm
 OPERATING TEMPERATURE: -20°C to 70°C

Materials

KNOB: POM
 FRAME: SPCC
 CONTACT: Silver clad
 TERMINAL: Silver plated

SS-14D0839-VG 5 PA 1P4T

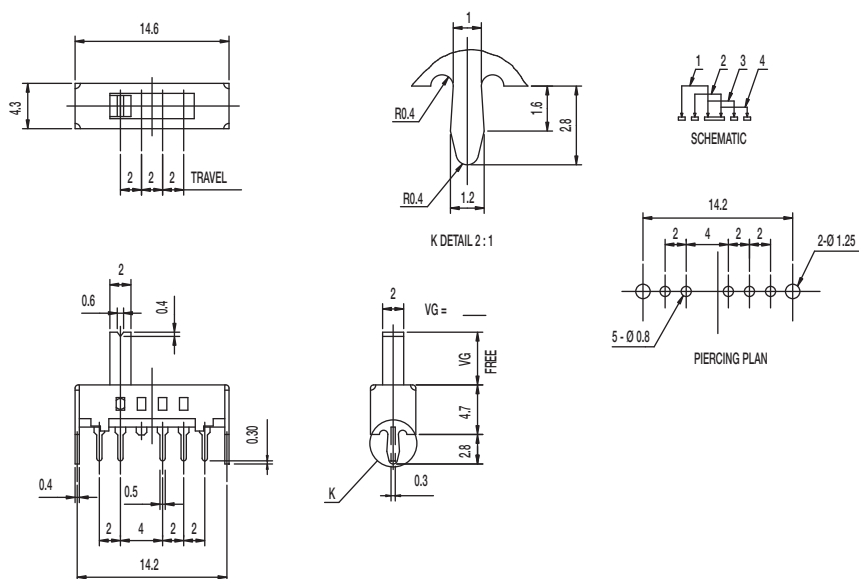

Specifications

CONTACT RATING: 0.3A @ 30 VDC
 INITIAL CONTACT RESISTANCE: 30 m ohms max.
 INSULATION RESISTANCE: 100 M ohms min.
 DIELECTRIC STRENGTH: 500 V AC (50-60 Hz) between open terminals and between the frame and terminal.
 OPERATING LIFE: 10,000 cycles without load; 5,000 cycles with load
 OPERATING FORCE: 250 ± 100 gf (2.45 ± 0.98N)
 TRAVEL: 2 ± 0.3 mm
 OPERATING TEMPERATURE: -20°C to 70°C

Materials



KNOB: PA
 FRAME: SPCC
 CONTACT: Silver clad
 TERMINAL: Silver plated



Dimensions are shown: mm
 Specifications and dimensions subject to change

Snap-acting Product Selection Guide

Snap-acting





| | | | | | | | |
|------------------------|---|---|---|--|---|---|---|
| Snap-acting |  |  |  |  |  |  |  |
| Series | TF | TFS | TF2 | TM | LC | LCA | LCS |
| Switch Type | Miniature | Sealed Miniature | Sealed Miniature | Miniature | Subminiature Precision | Subminiature | Sealed Subminiature |
| Poles/Throws | SPST, SPDT | SPDT | SPDT | SPST, SPDT | SPST, SPDT | SPDT | SPST |
| Maximum Current | 21 Amps | 10 Amps | 10 Amps | 15 Amps | 10.1 Amps | 10 Amps | 6 Amps |
| Terminations | | | | | | | |
| Solder | • | | • | • | • | • | • |
| Turret | | | | | | | |
| Quick Connect | • | • | • | • | • | • | • |
| Screw | | | • | • | | | |
| Wire Leads | | • | | | • | | • |
| PC | | | | | • | • | • |
| Formed PC | | | | | • | • | |
| Extended Operations | • | • | | • | • | • | |
| Sealed | | • | | | | | • |
| Page No. | J-6 | J-12 / J-16 | J-20 | J-26 | J-32 | J-36 | J-40 |

| | | | | | | | | |
|------------------------|---|---|---|---|--|---|---|---|
| Snap-acting |  |  |  |  |  |  |  |  |
| Series | MM | ZM | ZMA | ZMB | ZMS | ZMSM | MDS | HB |
| Switch Type | Subminiature Precision | Subminiature | Subminiature | Subminiature | Sealed Subminiature | Sealed Subminiature | Subminiature | Standard Precision |
| Poles/Throws | SPDT | SPDT | SPDT | SPDT | SPDT | SPDT | SPDT | SPST, SPDT |
| Maximum Current | 7 Amps | 3 Amps | 3 Amps | 0.1 Amps | 3 Amps | 3 Amps | 300 m Amps | 20 Amps |
| Terminations | | | | | | | | |
| Solder | | | • | • | • | • | • | • |
| Quick Connect | | | | | | | | • |
| Wire Leads | | | | | • | • | | |
| Screw | | | | | | | | • |
| PCB Thru-hole | • | • | • | • | • | • | • | |
| Flat & Step Base | | | | | | | | • |
| Bushing | | | | | | | | 15/32-32 |
| Sealed | | | | | • | • | | |
| Page No. | J-44 | J-47 | J-50 | J-54 | J-57 | J-61 | J-65 | J-71 |



Dimensions are shown: Inch (mm)
Specifications and dimensions subject to change

Snap-acting Product Selection Guide

| Snap-acting |  |  |  |  |
|------------------------|---|---|---|--|
| Series | A | TL | DS | LCB |
| Switch Type | General Purpose | Door Interlock | Door Interlock | Subminiature |
| Poles/Throws | SPST, SPDT, DP | SPDT | SPDT, DPDT | SPST, SPDT |
| Maximum Current | 30.1 Amps | 15 Amps | 0.1, 10, 16A | 5A |
| Terminations | | | | |
| Solder | | | | • |
| Quick Connect | • | • | • | • |
| Wire Leads | | | | |
| Screw | | • | | |
| PCB Thru-hole | | | | • |
| Flat & Step Base | | | | |
| Bushing | 3/8-23 | | | |
| Page No. | J-77 | J-82 | J-85 | J-88 |



Snap-acting





Snap-acting Technical Data

HOW TO CHOOSE PRECISION SNAP-ACTING SWITCHES AND ACTUATORS

This catalog describes electric switches that satisfy the following definition: "A precision snap-acting switch is a mechanically operated electric switch having predetermined and accurately controlled characteristics and having contacts other than blade-and-jaw, or mercury-type, where the maximum separation between any butting contacts is 1/8 inch."

In choosing a switch, the first thing to consider is its electrical rating. As a basic part of an electric control system, the switch must be able to carry the full load current in the system, to interrupt this current, and to handle any surge of current that may occur when the switch contacts close or any transients that occur when contacts open.

The method of applying mechanical force to operate the switch influences the choice of actuator. Basic switches are provided with leaf spring, levers, or other linkages between the switch plunger and the actuating device, which are typically used to provide additional overtravel and reduce the operating force. The differential travel measured at the free end of the leaf or lever is considerably greater than that measured at the switch plunger and max. operating force is adequately smaller. Table 1 relates types of actuators to means of applying operating force.

| MOTION OF APPLIED OPERATING FORCES | ACTUATOR | | | | | | | | |
|--|----------------|--------------------|----------------|------|-------------|--------------|---------------------|-----------------------------|------------------------------------|
| | Pin | Overtravel Plunger | Roller Plunger | Leaf | Roller Leaf | Hinged Lever | Hinged Roller Lever | Reverse-Acting Hinged Lever | Reverse-Acting Hinged Roller Lever |
| | Basic | D, Q, J | R | L | W | T | A | Y | F |
|  CAM Rotary | | | √ | √ | √ | √ | √ | √ ¹ | √ ¹ |
|  LEVER Angular | √ | √ ² | √ ² | √ | √ | √ | √ | √ | √ |
|  SLIDE Wedge | | | √ | | √ | | √ | | √ |
|  PLUNGER In-Line | √ ³ | √ | | √ | | √ | | √ | |
|  BI-METAL or BELLOWS Slow In-Line | √ | √ | | | | | | | |

√ Suitable for this actuating method.

¹ Where large overtravel is required.

² Do not use when there is side thrust.

³ Use only where the actuating device contains provisions for absorbing excess over travel.

ELECTRICAL LIFE CHARACTERISTICS FOR SNAP-ACTING SWITCHES

The primary limitation to electrical life of a switch is wear of the contacts. In general, contacts wear out more quickly as current or voltage is increased and as power-factor is decreased. This is indicated by the graph below, which shows electrical life of switches tested under ordinary atmospheric conditions, operated 60 times a minute, with AC power handled on both the normally open and the normally closed contacts. The high inrush current encountered in lamp loads and in motor or other inductive loads is responsible for decreased contact life under such loading.

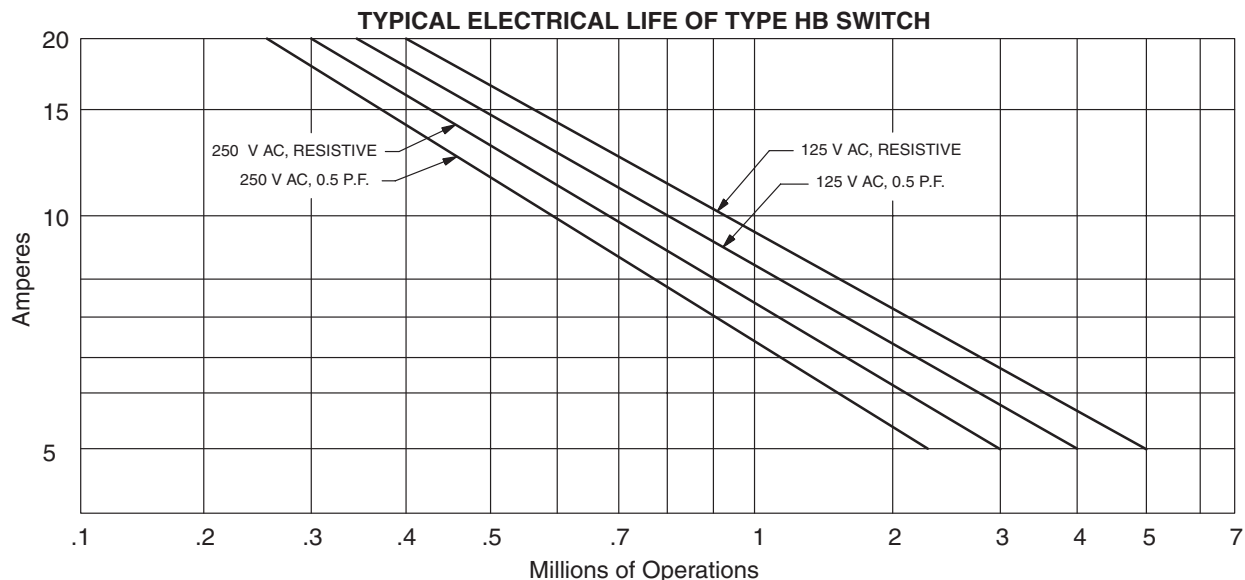

Dimensions are shown: Inch (mm)
Specifications and dimensions subject to change

Snap-acting Technical Data

MECHANICAL LIFE CHARACTERISTICS FOR SNAP-ACTING SWITCHES

Fatigue of the internal spring blade is the limiting factor in the mechanical life of a switch. This fatigue can often be reduced and the life thereby extended, by reducing overtravel. One method is to use a leaf or lever actuator or a plunger containing an overtravel-absorbing spring. Tests on switches of the types covered in this catalog indicate that the mechanical life of a lever actuated switch is more than double that of a switch having the operating force applied directly on the pin.

Mechanical life is also affected by the combination of total travel and operating force. Thus a high-sensitivity switch which has small travel and light force, has about twice the life expectancy of a high current type switch, in which the travel/ force combination is relatively high. Experience indicates that million of operations is a reasonable mechanical life expectancy for a basic snap switch.

For the best mechanical life, the applied overtravel force should not exceed three times the operating force.

AC RATINGS FOR SNAP-ACTING SWITCHES

Switches used to control alternating current loads, up to the ratings shown in this catalog, will maintain repeatability of characteristics and provide long electrical life (refer to graph on page K-3). In special circumstances, higher currents or voltages may be controlled, but changes in performance must be anticipated.

Switches used to control "dry circuits" can be furnished, but factory recommendations should be secured.

DC RATINGS FOR SNAP-ACTING SWITCHES

To use the table below, determine the contact separation of the switch and select the ratings from the appropriate line. The maximum current rating must be limited to the current value listed for that switch type in the body of the catalog.

| CONTACT SEPARATION | DIRECT CURRENT VOLTAGE | ACTUATOR | | | | INDUCTIVE | | | |
|--------------------|------------------------|-----------------------|-------------------------|-----------------------|-------------------------|--------------------------------|-------------------------|-----------------------|-------------------------|
| | | Heater Load | | Lamp Load (tungsten) | | Motor, Relay, or Solenoid Load | | | |
| | | Normally Open Contact | Normally Closed Contact | Normally Open Contact | Normally Closed Contact | Sea Level | | 50,000 Feet | |
| | | | | | | Normally Open Contact | Normally Closed Contact | Normally Open Contact | Normally Closed Contact |
| Inches | Volts | Amperes | Amperes | Amperes | Amperes | Amperes | Amperes | Amperes | Amperes |
| .010 | 6-8 | 15.0 | 20.0 | 1.5 | 3.0 | 8.0 | 8.0 | 7.0 | 7.0 |
| | 12-14 | 15.0 | 20.0 | 1.5 | 3.0 | 5.0 | 5.0 | 5.0 | 5.0 |
| | 24-30 | 2.0 | 2.0 | 1.5 | 2.0 | 1.0 | 1.0 | 1.0 | 1.0 |
| | 110-115 | 0.4 | 0.4 | 0.4 | 0.4 | 0.03 | 0.03 | 0.02 | 0.02 |
| | 220-230 | 0.2 | 0.2 | 0.2 | 0.2 | 0.02 | 0.02 | 0.01 | 0.01 |
| .020 | 6-8 | 15.0 | 20.0 | 1.5 | 3.0 | 15.0 | 20.0 | 15.0 | 15.0 |
| | 12-14 | 15.0 | 20.0 | 1.5 | 3.0 | 10.0 | 10.0 | 8.0 | 8.0 |
| | 24-30 | 6.0 | 6.0 | 1.5 | 2.0 | 5.0 | 5.0 | 2.0 | 2.0 |
| | 110-115 | 0.4 | 0.4 | 0.4 | 0.4 | 0.05 | 0.05 | 0.03 | 0.03 |
| | 220-230 | 0.2 | 0.2 | 0.2 | 0.2 | 0.03 | 0.03 | 0.02 | 0.02 |
| .040 | 6-8 | 15.0 | 20.0 | 1.5 | 3.0 | 15.0 | 20.0 | 15.0 | 15.0 |
| | 12-14 | 15.0 | 20.0 | 1.5 | 3.0 | 15.0 | 20.0 | 15.0 | 15.0 |
| | 24-30 | 10.0 | 10.0 | 1.5 | 2.0 | 10.0 | 10.0 | 5.0 | 5.0 |
| | 110-115 | 0.6 | 0.6 | 0.6 | 0.6 | 0.1 | 0.1 | 0.05 | 0.05 |
| | 220-230 | 0.3 | 0.3 | 0.3 | 0.3 | 0.05 | 0.05 | 0.03 | 0.03 |
| .070 | 6-8 | 15.0 | 20.0 | 1.5 | 3.0 | 15.0 | 20.0 | 15.0 | 15.0 |
| | 12-14 | 15.0 | 20.0 | 1.5 | 3.0 | 15.0 | 20.0 | 15.0 | 15.0 |
| | 24-30 | 15.0 | 20.0 | 1.5 | 2.0 | 10.0 | 10.0 | 7.5 | 7.5 |
| | 110-115 | 0.75 | 0.75 | 0.75 | 0.75 | 0.4 | 0.4 | 0.2 | 0.2 |
| | 220-230 | 0.3 | 0.3 | 0.3 | 0.3 | 0.2 | 0.2 | 0.1 | 0.1 |

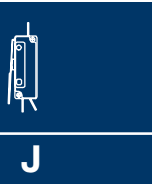

TF Series Miniature Snap-acting Switches



Features/Benefits

- Broad range of operating forces
- Ratings up to 21 AMPS
- Wide variety of actuator styles
- Quick connect terminations

Typical Applications

- Motor controls
- Thermostatics
- Portable tools



Specifications

CONTACT RATING: From low level* to 21 AMPS @ 277 V AC.
 ELECTRICAL LIFE: 300,000 cycles at 10 AMPS @ 250 V AC, consult Customer Service Center for typical life of higher rated switches.
 INSULATION RESISTANCE: 1,000 M ohm min.
 DIELECTRIC STRENGTH: 1,500 Vrms min. @ sea level.
 OPERATING TEMPERATURE: -40°F to 185°F (-40°C to 85°C).
 OPERATING FORCE: From 15 to 400 grams at actuator button available.
 MOUNTING: Torque screws 2-5 in/lbs.

* Low Level=conditions where no arcing occurs during switching, i.e., 0.4 VA max. @ 20 V AC or DC max. Standard electrical life per UL 1054, rated for 6,000 operations.

Materials

SWITCH HOUSING: Thermoplastic (UL 94V-0).
 ACTUATOR BUTTON: Thermoplastic (UL 94V-0).
 SPRING: Copper alloy.
 PIVOT: Brass alloy.
 MOVABLE CONTACTS: Gold alloy for ratings 1 AMP or less.
 Fine silver for ratings greater than 1 AMP up to 15 AMPS.
 Precious metal alloy for ratings greater than 15 AMPS.
 STATIONARY CONTACTS: Gold alloy for ratings 1 AMP or less.
 Fine silver for ratings greater than 1 AMP.
 TERMINALS: Brass alloy for ratings up to 10 AMPS.
 Copper alloy for ratings greater than 10 AMPS.

NOTE: Specifications and materials listed above are switches with standard options. For information on specific and custom switches, consult Customer Service Center.



Snap-acting

Build-A-Switch

To order, simply select desired option from each category and place in the appropriate box. Available options are shown and described on pages J-6 through J-11. For additional options not shown in catalog, consult Customer Service Center.

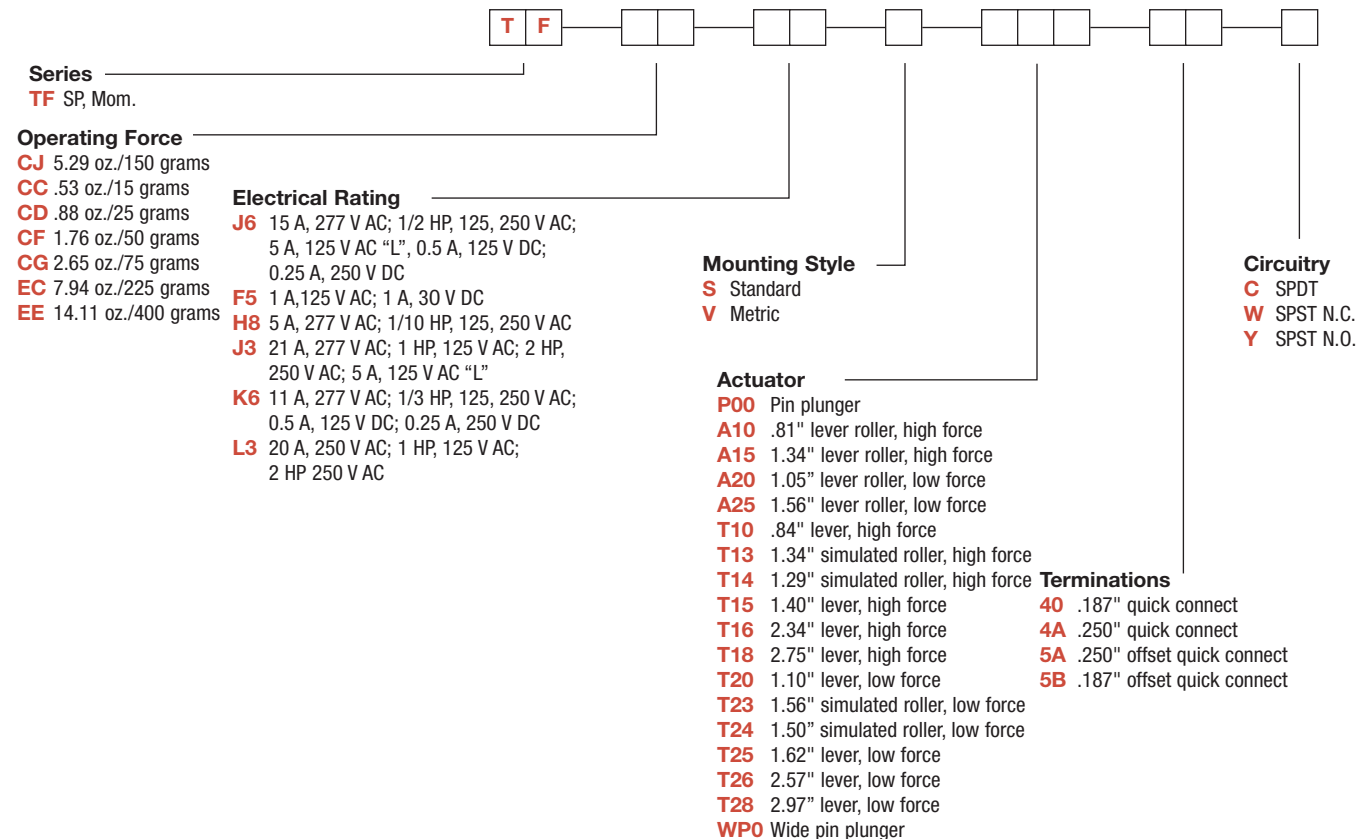

Dimensions are shown: Inch (mm)
 Specifications and dimensions subject to change

TF Series Miniature Snap-acting Switches

SERIES

TF MINIATURE SNAP-ACTING SWITCHES – SP MOMENTARY

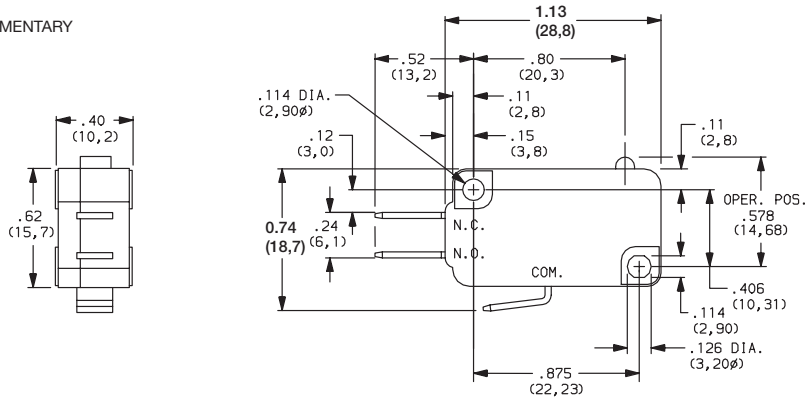

OPERATING FORCE

| OPTION CODE | BASIC SWITCH OPERATING FORCE (OZ./GRAMS) |
|-------------|--|
| CC | .53 15 |
| CD | .88 25 |
| CF | 1.76 50 |
| CG | 2.65 75 |
| CJ | 5.29 150 |
| EC | 7.94 225 |
| EE* | 14.11 400 |

*Minimums may apply, consult Customer Service Center.

Operating Force option 'CC' not available with 'T18 & T26' Actuator options.
Operating force varies with actuator option, see ACTUATOR option section.

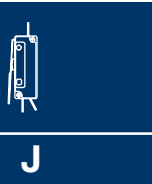

Snap-acting

ELECTRICAL RATING

| OPTION CODE | RoHS COMPLIANT * | RoHS COMPATIBLE * | CONTACT MATERIAL | | ELECTRICAL RATING |
|-------------|------------------|-------------------|------------------|--------------------|--|
| | | | MOVABLE CONTACT | STATIONARY CONTACT | |
| F5 | Yes | Yes | Gold alloy | Gold alloy | From low level* to 1 AMP @ 125 V AC, 1 AMP @ 30 V DC. |
| H8 | Yes | Yes | Fine Silver | Fine Silver | 5 AMPS @ 277 V AC; 1/10 HP @ 125 & 250 V AC. |
| J3 | Yes | Yes | | | 21 AMPS @ 277 V AC; 1 HP @ 125 V AC; 2 HP @ 250 V AC; 5 AMPS @ 125 V AC "L". |
| J6 | Yes | Yes | | | 15 AMPS @ 277 V AC; 1/2 HP @ 125 & 250 V AC; 5 AMPS @ 125 V AC "L". 0.5 AMP @ 125 V DC; 0.25 AMP @ 250 V DC. |
| K6 | Yes | Yes | | | 11 AMPS @ 277 V AC; 1/3 HP @ 125 & 250 V AC; 0.5 AMP @ 125 V DC; 0.25 AMP @ 250 V DC. |
| L3 | Yes | Yes | Silver alloy | | 20 AMPS @ 250 V AC; 1 HP @ 125 V AC; 2 HP @ 250 V AC |

* Note: See Technical Data section of this catalog for RoHS compliant and compatible definitions and specifications.

All models

Consult Customer Service center for availability and delivery of nonstandard ratings.

* Low Level=conditions where no arcing occurs during switching, i.e., 0.4 VA max. @ 20 V AC or DC max.



Third Angle Projection

Dimensions are shown: Inches (mm)
Specifications and dimensions subject to change



TF Series Miniature Snap-acting Switches

ELECTRICAL RATING

| ELECTRICAL RATING | AMPS (REF.) | OPERATING FORCE | | | | | | |
|-------------------|-------------|-----------------|---------|---------|---------|----------|----------|----------|
| | | CC (15) | CD (25) | CF (50) | CG (75) | CJ (150) | EC (225) | EE (400) |
| F5 | 1 | • | • | • | • | • | • | |
| H8 | 5 | • | • | • | • | • | • | • |
| J3 | 21 | X | X | X | X | • | • | • |
| J6 | 15 | X | X | X | X | • | • | • |
| K6 | 11 | X | • | • | • | • | • | • |
| L3 | 20 | X | X | X | X | • | • | • |

- AVAILABLE
- X NOT AVAILABLE
- ** Available with 4A & 5A terminations only, see page J-10.

All models **c** **AL** **us**

Consult Customer Service center for availability and delivery of nonstandard ratings.

* Low Level=conditions where no arcing occurs during switching, i.e., 0.4 VA max. @ 20 V AC or DC max.

MOUNTING STYLE

S STANDARD
For 4-40 screw size

V Metric
For 3 mm screw size

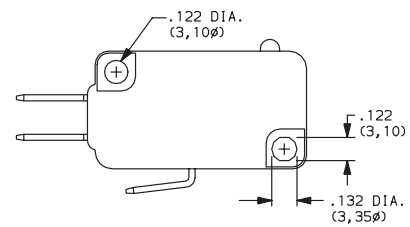
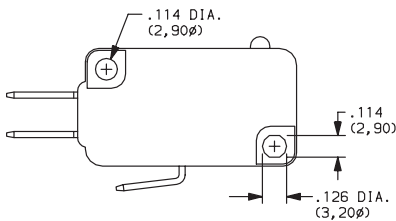

Dimensions are shown: Inch (mm)
Specifications and dimensions subject to change

TF Series Miniature Snap-acting Switches

ACTUATOR

| OPTION CODE | FIG. | DIM. A | DIM. B | DIM. C | DIM. D |
|-------------|------|----------------|---------------|-------------------------------|--------------------|
| P00 | 1 | .80 (20,3) | — | .578 ± .015 (14,68 ± 0,38) | — |
| A10 | 2 | .81 (20,6) | .32 (8,1) | .810 ± .020 (20,57 ± 0,51) | .19 dia. (4,80) |
| A15 | 2 | 1.34 (34,0) | .32 (8,1) | .810 ± .030 (20,57 ± 0,76) | .19 dia. (4,80) |
| A20 | 2 | 1.05 (26,7) | .54 (13,7) | .810 ± .050 (20,57 ± 1,27) | .19 dia. (4,80) |
| A25 | 2 | 1.56 (39,6) | .54 (13,7) | .810 ± .075 (20,57 ± 1,91) | .19 dia. (4,80) |
| T10 | 3 | .84 (21,3) | .32 (8,1) | .600 ± .020 (15,24 ± 0,51) | — |
| T15 | 3 | 1.40 (35,6) | .32 (8,1) | .600 ± .040 (15,24 ± 1,02) | — |
| T16 | 3 | 2.34 (59,4) | .32 (8,1) | .600 ± .065 (15,24 ± 1,65) | — |
| T18 | 3 | 2.75 (69,9) | .32 (8,1) | .600 ± .080 (15,24 ± 2,03) | — |
| T20 | 3 | 1.10 (27,9) | .54 (13,7) | .600 ± .050 (15,24 ± 1,27) | — |
| T25 | 3 | 1.62 (41,1) | .54 (13,7) | .600 ± .070 (15,24 ± 1,78) | — |
| T26 | 3 | 2.57 (65,3) | .54 (13,7) | .600 ± .150 (15,24 ± 3,81) | — |
| T28 | 3 | 2.97 (75,4) | .54 (13,7) | .600 ± .187 (15,24 ± 4,75) | — |
| T13 | 4 | 1.34 (34,0) | .32 (8,1) | .810 ± .030 (20,57 ± 0,76) | .19 dia. (4,80) |
| T14 | 4 | 1.29 (32,8) | .32 (8,1) | .730 ± .030 (18,54 ± 0,76) | .19 dia. (6,40) |
| T23 | 4 | 1.56 (39,6) | .54 (13,7) | .810 ± .065 (20,57 ± 1,65) | .19 dia. (4,80) |
| T24 | 4 | 1.50 (38,1) | .54 (13,7) | .730 ± .060 (18,54 ± 1,52) | .25 dia. (6,40) |
| WP0 | 5 | .80 (20,3) | — | .635 ± .015 (16,13 ± 0,38) | — |

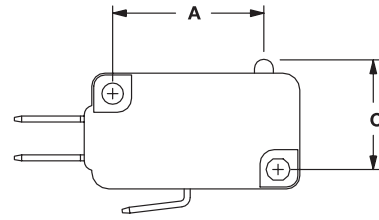

FIG. 1
Pin Plunger

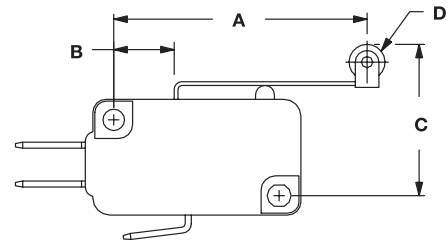

FIG. 2
Lever Roller

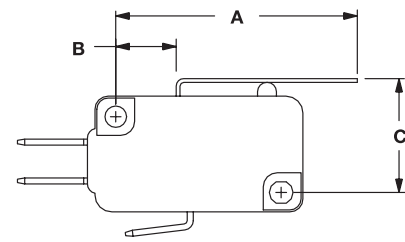

FIG. 3
Lever

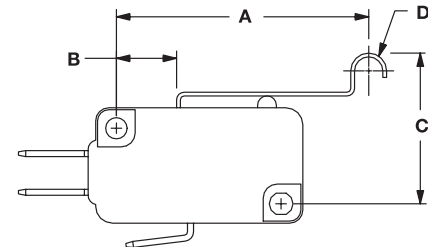

FIG. 4
Simulated Roller

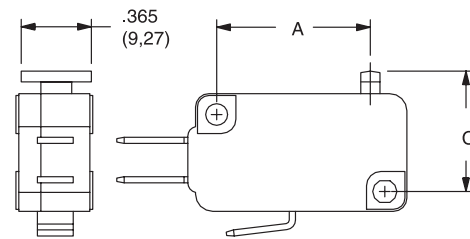
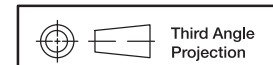

FIG. 5
Wide Pin



Third Angle Projection

Dimensions are shown: Inches (mm)
Specifications and dimensions subject to change

NOTE: Switch characteristics chart on following page.

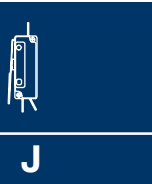

Snap-acting

TF Series Miniature Snap-acting Switches

ACTUATOR 

SWITCH CHARACTERISTICS

| OPTION CODE | MAXIMUM OPERATING FORCE (OZ./GRAMS) | | | | | | MINIMUM RELEASE FORCE (OZ./GRAMS) | | | | | | MAXIMUM DIFFERENTIAL TRAVEL | MAXIMUM PRETRAVEL | MINIMUM OVERTRAVEL | | |
|-------------|-------------------------------------|------------|------------|------------|-------------|-------------|-----------------------------------|-----------|-----------|-----------|------------|------------|-----------------------------|-------------------|--------------------|------------------|-----------------|
| | CC (15) | CD (25) | CF (50) | CG (75) | CJ (150) | EC (225) | EE (400) | CC (15) | CD (25) | CF (50) | CG (75) | CJ (150) | EC (225) | EE (400) | ALL FORCES | ALL FORCES | ALL FORCES |
| A10 | .63 18 | 1.06 30 | 2.29 65 | 3.17 90 | 6.35 180 | 7.94 225 | 14.11 400 | .21 6 | .35 10 | .35 10 | .53 15 | .71 20 | 1.98 56 | 3.88 110 | .015 (0,38) | .060 (1,52) | .030 (0,76) |
| A15 | .28 8 | .42 12 | 1.06 30 | 1.59 45 | 3 85 | 4.59 130 | 7.94 225 | .07 2 | .14 4 | .14 4 | .18 5 | .35 10 | .71 20 | 2.82 80 | .030 (0,76) | .100 (2,54) | .065 (1,65) |
| A20 | 0.53 15 | 0.71 20 | 1.41 40 | 2.12 60 | 4.23 120 | 6 170 | 9.7 275 | 0.07 2 | 0.11 3 | 0.11 3 | 0.18 5 | 0.42 12 | 0.71 20 | 1.41 40 | 0.025 (0,64) | 0.12 (3,05) | 0.055 (1,40) |
| A25 | .18 5 | .28 8 | .56 16 | .85 24 | 1.69 48 | 2.65 75 | 4.41 125 | .04 1 | .07 2 | .07 2 | .07 2 | .21 6 | .35 10 | .71 20 | .050 (1,27) | .250 (6,35) | .120 (3,05) |
| P00 | .53 15 | .88 25 | 1.76 50 | 2.65 75 | 5.29 150 | 7.94 225 | 14.11 400 | .21 6 | .35 10 | .35 10 | .53 15 | 1.23 35 | 1.98 56 | 3.88 110 | .010 (0,25) | .047 (1,19) | .050 (1,27) |
| T10 | .63 18 | 1.06 30 | 2.29 65 | 3.17 90 | 6.35 180 | 7.94 225 | 14.11 400 | .21 6 | .35 10 | .35 10 | .53 15 | .71 20 | 1.98 56 | 3.88 110 | .015 (0,38) | .060 (1,52) | .030 (0,76) |
| T13 | .28 8 | .42 12 | 1.06 30 | 1.59 45 | 3 85 | 4.59 130 | 7.94 225 | .07 2 | .14 4 | .14 4 | .18 5 | .35 10 | .71 20 | 2.82 80 | .030 (0,76) | .100 (2,54) | .065 (1,65) |
| T14 | .28 8 | .42 12 | 1.23 35 | 1.76 50 | 3.17 90 | 4.76 135 | 7.94 225 | .07 2 | .14 4 | .14 4 | .18 5 | .35 10 | .71 20 | 2.82 80 | .030 (0,76) | .100 (2,54) | .060 (1,52) |
| T15 | .25 7 | .42 12 | 1.06 30 | 1.41 40 | 2.82 80 | 4.41 125 | 7.94 225 | .07 2 | .14 4 | .14 4 | .18 5 | .28 8 | .63 18 | 2.82 80 | .030 (0,76) | .110 (2,79) | .065 (1,65) |
| T16 | .18 5 | .28 8 | .53 15 | .78 22 | 1.59 45 | 2.47 70 | 4.23 120 | .04 1 | .07 2 | .07 2 | .07 2 | .28 8 | .35 10 | .71 20 | .045 (1,14) | .250 (6,35) | .125 (3,18) |
| T18 | N/A | .21 6 | .42 12 | .71 20 | 1.41 40 | 2.12 60 | 3.53 100 | N/A | .04 1 | .04 1 | .07 2 | .18 5 | .28 8 | .56 16 | .062 (1,57) | .300 (7,62) | .155 (3,94) |
| T20 | .53 15 | .71 20 | 1.41 40 | 2.12 60 | 4.23 120 | 6 170 | 9.70 275 | .21 6 | .35 10 | .35 10 | .53 15 | .71 20 | 1.98 56 | 3.88 110 | .030 (0,76) | .140 (3,56) | .060 (1,52) |
| T23 | .18 5 | .28 8 | .56 16 | .85 24 | 1.69 48 | 2.65 75 | 4.41 125 | .04 1 | .07 2 | .07 2 | .07 2 | .21 6 | .35 10 | .71 20 | .050 (1,27) | .250 (6,35) | .120 (3,05) |
| T24 | 0.18 5 | 0.28 8 | 0.56 16 | 0.88 25 | 1.76 50 | 2.65 75 | 4.76 135 | 0.04 1 | 0.07 2 | 0.07 2 | 0.11 3 | 0.21 6 | 0.35 10 | 0.71 20 | .005 (1,27) | 0.23 (5,84) | 0.11 (2,79) |
| T25 | .18 5 | .28 8 | .53 15 | .88 25 | 1.59 45 | 2.47 70 | 4.23 120 | .04 1 | .07 2 | .07 2 | .07 2 | .21 6 | .35 10 | .99 28 | .055 (1,40) | .250 (6,35) | .125 (3,18) |
| T26 | N/A | .14 4 | .28 8 | .42 12 | .85 24 | 1.27 36 | 2.26 64 | N/A | .04 1 | .04 1 | .05 1.5 | .12 3.5 | .21 6 | .39 11 | .100 (2,54) | .500 (12,70) | .235 (5,97) |
| T28 | N/A | N/A | N/A | 0.42 12 | 0.71 20 | 1.06 30 | 1.94 55 | N/A | N/A | N/A | 0.04 1 | 0.11 3 | 0.18 5 | 0.32 9 | 0.12 (3,05) | .0560 (14,22) | 0.285 (7,24) |
| WP0 | .53 15 | .88 25 | 1.76 50 | 2.65 75 | 5.29 150 | 7.94 225 | 14.11 400 | .21 6 | .35 10 | .35 10 | .53 15 | 1.23 35 | 1.97 56 | 3.88 110 | .010 (0,25) | .047 (1,19) | .030 (0,51) |

NOTE: For basic switch operating forces, see page J-6.

HIGH FORCE, LOW MOTION PIVOT POSITION

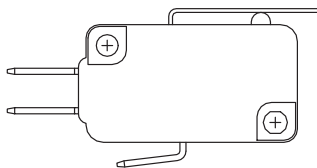

Available with actuators A10, A15, T10, T13, T14, T15, T16 and T18.

LOW FORCE, HIGH MOTION PIVOT POSITION

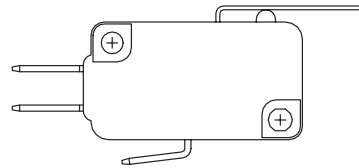

Available with actuators A20, A25, T20, T23, T24, T25, T26, and T28.

NOTE: Lever actuator options are available in either of two pivot positions. Levers located in the forward pivot position have lower forces and higher motions. Levers located in the rear pivot position have higher forces and lower motions.



Dimensions are shown: Inch (mm)
Specifications and dimensions subject to change

TF Series Miniature Snap-acting Switches

TERMINATIONS

40 .187" QUICK CONNECT

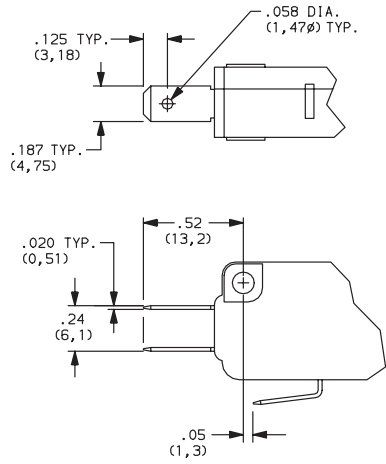

4A .250" QUICK CONNECT

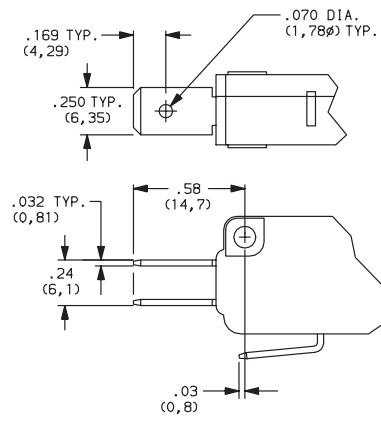

5A OFFSET .250" QUICK CONNECT

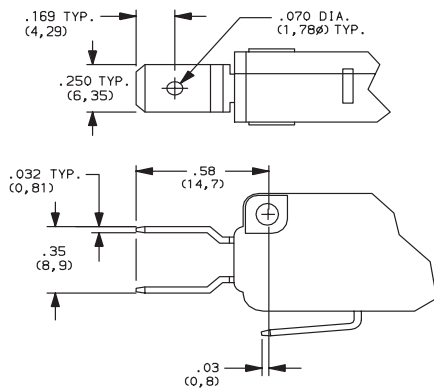

5B OFFSET .187" QUICK CONNECT

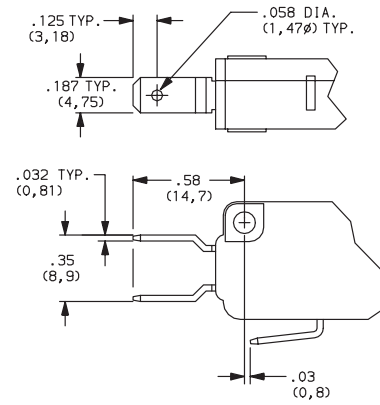

CIRCUITRY

- C** SPDT (Single Pole, Double Throw)
- W** SPST N.C. (Single Pole, Single Throw, Normally Closed)
- Y** SPST N.O. (Single Pole, Single Throw, Normally Open)

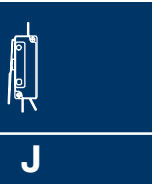

Snap-acting



Dimensions are shown: Inches (mm)
Specifications and dimensions subject to change

TFS Series Splash Proof Miniature Snap-acting Switches



Features/Benefits

- **Reliable snap action mechanism**
- **Low cost - high performance**
- **RoHS compatible**

Typical Applications

- **Alarm devices / Home security**
- **Air conditioner**
- **Food processor**
- **Water heaters**
- **Industrial**
- **Forklifts**

UL61058-1  

Specifications

CONTACT RATING / ELECTRICAL LIFE:

- 0.1A @ 125/250 V AC / 10,000 operations
- 3A @ 125/250 VAC / 10,000 operations
- 6A @ 125/250 VAC / 10,000 operations
- 10A @ 125/250 VAC / 10,000 operations

ELECTRICAL OPERATING FREQUENCY: 10-30 operations per min.

MECHANICAL LIFE: 1,000,000 operations

MECHANICAL OPERATING FREQUENCY: 120 operations per min.

INSULATION RESISTANCE: (at 500 VDC/minute) 100 M ohm min.

DIELECTRIC STRENGTH: 1500 VAC (50 -60 Hz)

OPERATING TEMPERATURE: -40°C to 85°C (with no icing)

OPERATING FORCE: 200 grams.

Materials

CASE: Nylon

COVER: PBT

ACTUATOR: PBT

MOVABLE CONTACTS: Silver alloy

TERMINALS: Brass

LEVER: Stainless steel

WIRE: PVC+CU

NOTE: Specifications and materials listed above are for switches with standard options. For information on specific and custom switches, consult Customer Service Center.



Snap-acting

Build-A-Switch

To order, simply select desired option from each category and place in the appropriate box. Available options are shown and described on pages J-12 thru J-15. For additional options not shown in catalog, consult Customer Service Center.

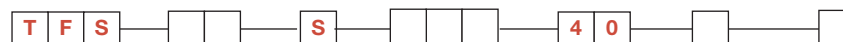

Electrical Rating

| ELECTRICAL RATING | AMPS (GRAMS) | OPERATING FORCE | | | | |
|-------------------|--------------|-----------------|--------|---------|---------|---------|
| | | S (200) | D (50) | J (100) | L (150) | H (300) |
| 01 | 0.1 | • | • | • | • | • |
| 03 | 3 | • | • | • | • | • |
| 06 | 6 | • | • | • | • | • |
| 10 | 10 | • | X | X | X | • |

- Available
- X Not available

Operating Force

- S** 200 grams
- D** 50 grams
- J** 100 grams
- L** 150 grams
- H** 300 grams

Actuator Lever Fixed

- P00** Button
- T10** Lever - high force
- T20** Lever - low force
- A05** Lever roller - High force, short lever
- A10** Lever roller - high force
- A20** Lever roller - low force
- A25** Lever roller - Low force, short lever

Terminal Type

- 40** .187" quick connect

Circuit Arrangement

- C** SPDT
- Y** SPST N.O.
- W** SPST N.C.

Mounting Hole Size

- NONE** 3.1 mm (3 mm screw clearance hole)
- S** 2.9 mm (4-40 screw clearance hole)



TFS Series Splash Proof Miniature Snap-acting Switches

SERIES

TFS SUB-MINIATURE SNAP-ACTING SWITCHES

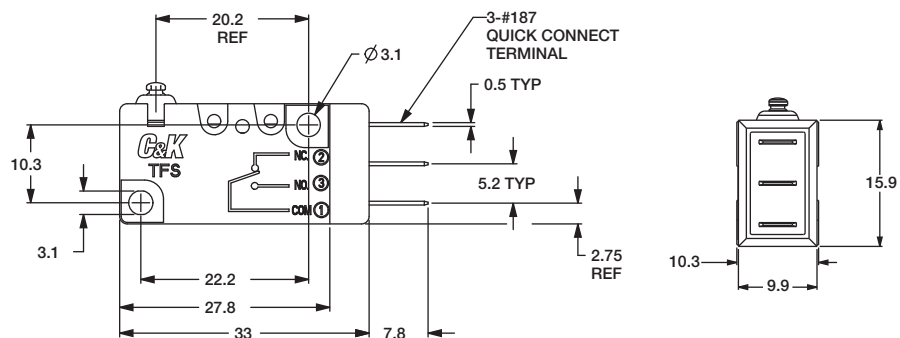

ELECTRICAL RATING

| OPTION CODE | RoHS COMPLIANT | RoHS COMPATIBLE | ELECTRICAL RATING |
|-------------|----------------|-----------------|--|
| 10 | Yes | Yes | 10A @ 125/250 V AC / 10,000 operations |
| 06 | Yes | Yes | 6A @ 125/250 VAC / 10,000 operations |
| 03 | Yes | Yes | 3A @ 125/250 VAC / 10,000 operations |
| 01 | Yes | Yes | 0.1A @ 125/250 VAC / 10,000 operations |



Snap-acting

OPERATING FORCE

| OPTION CODE | BASIC SWITCH OPERATING FORCE |
|-------------|------------------------------|
| S | 200 GRAMS |
| D | 50 grams |
| J | 100 grams |
| L | 150 grams |
| H | 300 grams |



Third Angle Projection

Dimensions are shown: mm
Specifications and dimensions subject to change



TFS Series Splash Proof Miniature Snap-acting Switches

ACTUATOR

P00 BUTTON

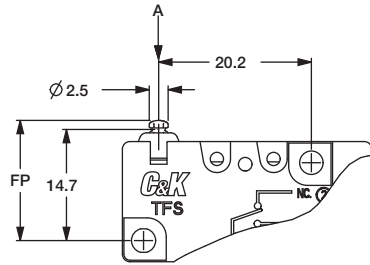

Measure at Point "A"

| | |
|----------------------------|---------------|
| Max. operating force | 200 grams |
| Min. release force | 30 grams |
| Operating position OP | 14.7 ± 0.4 mm |
| Max. movement differential | 0.4 mm |
| Min. over travel OT | 1.0 mm |
| Max. pre-travel PT | 1.2 mm |

T10 LEVER, HIGH FORCE

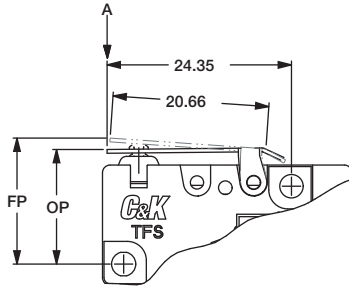

Measure at Point "A"

| | |
|----------------------------|---------------|
| Max. operating force | 160 grams |
| Min. release force | 25 grams |
| Operating position OP | 15.1 ± 0.6 mm |
| Max. movement differential | 0.6 mm |
| Min. over travel OT | 1.1 mm |
| Max. pre-travel PT | 2.6 mm |

T20 LEVER, LOW FORCE

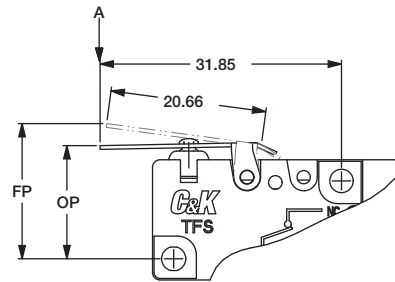

Measure at Point "A"

| | |
|----------------------------|-------------|
| Max. operating force | 90 grams |
| Min. release force | 10 grams |
| Operating position OP | 15 ± 1.1 mm |
| Max. movement differential | 1.1 mm |
| Min. over travel OT | 1.2 mm |
| Max. pre-travel PT | 5.1 mm |

A05 LEVER ROLLER
HIGH FORCE, SHORT LEVER

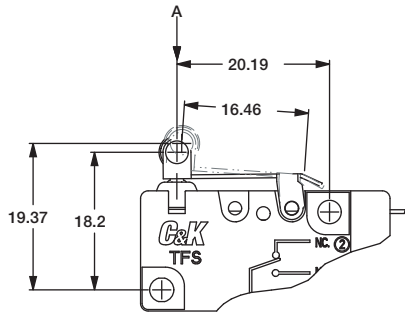

Measure at Point "A"

| | |
|----------------------------|---------------|
| Max. operating force | 200 grams |
| Min. release force | 30 grams |
| Operating position OP | 20.6 ± 0.5 mm |
| Max. movement differential | 0.5 mm |
| Min. over travel OT | 1.0 mm |
| Max. pre-travel PT | 2.1 mm |

A10 LEVER ROLLER
HIGH FORCE

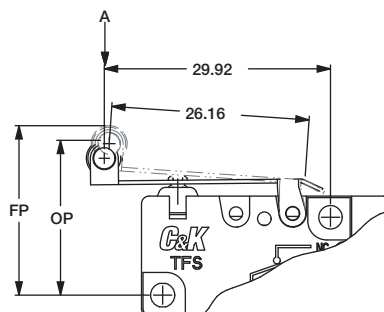

Measure at Point "A"

| | |
|----------------------------|---------------|
| Max. operating force | 130 grams |
| Min. release force | 20 grams |
| Operating position OP | 20.4 ± 0.7 mm |
| Max. movement differential | 0.7 mm |
| Min. over travel OT | 1.3 mm |
| Max. pre-travel PT | 3.3 mm |

A20 LEVER ROLLER
LOW FORCE

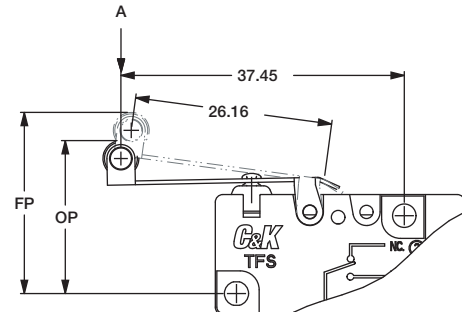

Measure at Point "A"

| | |
|----------------------------|---------------|
| Max. operating force | 70 grams |
| Min. release force | 10 grams |
| Operating position OP | 20.2 ± 1.2 mm |
| Max. movement differential | 1.4 mm |
| Min. over travel OT | 1.5 mm |
| Max. pre-travel PT | 6.5 mm |

Snap-acting

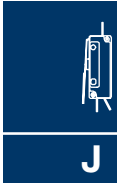

Third Angle
Projection

Dimensions are shown: mm
Specifications and dimensions subject to change



TFS Series Splash Proof Miniature Snap-acting Switches

ACTUATOR

A25 LEVER ROLLER
LOW FORCE, SHORT LEVER

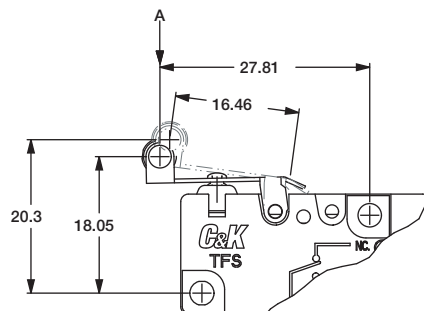

Measure at Point "A"

| | |
|----------------------------|---------------|
| Max. operating force | 150 grams |
| Min. release force | 15 grams |
| Operating position OP | 20.4 ± 0.9 mm |
| Max. movement differential | 0.9 mm |
| Min. over travel OT | 1.2 mm |
| Max. pre-travel PT | 4.2 mm |

TERMINAL TYPE

40 .187" QUICK CONNECT

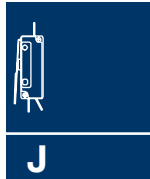
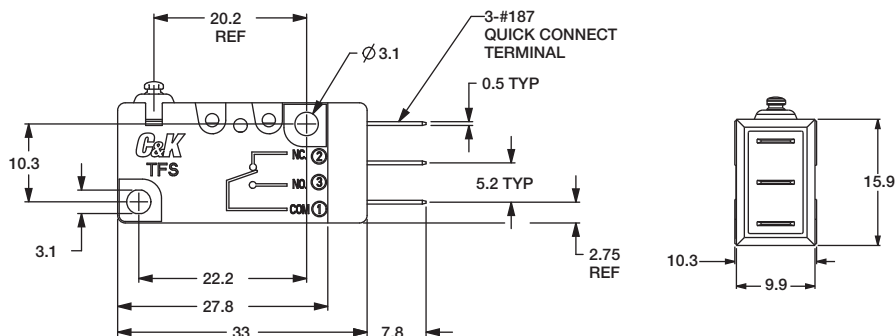

Snap-acting

CIRCUITRY

- C** SPDT (Single Pole, Double Throw)
- Y** SPST N.O. (Single Pole, Single Throw, Normally Open)
- W** SPST N.C. (Single Pole, Single Throw, Normally Closed)

MOUNTING HOLE SIZE

NONE 3.1 mm (3mm SCREW CLEARANCE HOLE)

S 2.9 mm (4-40 SCREW CLEARANCE HOLE)

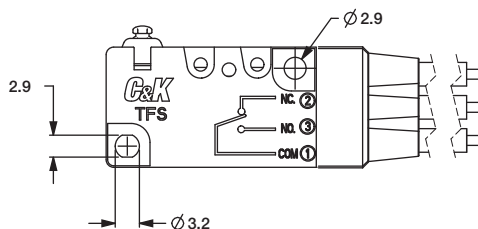
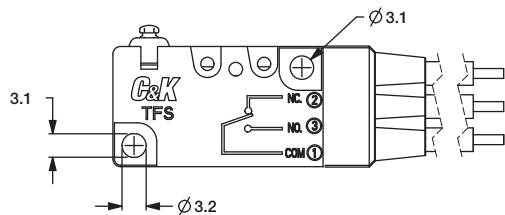

Third Angle
Projection
Dimensions are shown: mm
Specifications and dimensions subject to change

C&K

TFS Series Sealed Miniature Snap-acting Switches (Water Proof)



Features/Benefits

- IP67
- Reliable snap action mechanism
- Low cost - high performance
- RoHS compatible

Typical Applications

- Alarm devices / Home security
- Air conditioner
- Food processor
- Water heaters
- Industrial
- Forklifts

UL61058-1



Specifications

CONTACT RATING / ELECTRICAL LIFE:
 0.1A @ 125/250 V AC / 10,000 operations
 3A @ 125/250 VAC / 10,000 operations
 6A @ 125/250 VAC / 10,000 operations
 10A @ 125/250 VAC / 10,000 operations
 ELECTRICAL OPERATING FREQUENCY: 10-30 operations per min.
 MECHANICAL LIFE: 1,000,000 operations
 MECHANICAL OPERATING FREQUENCY: 120 operations per min.
 INSULATION RESISTANCE: (at 500 VDC/minute) 100 M ohm min.
 DIELECTRIC STRENGTH: 1500 VAC (50 -60 Hz)
 OPERATING TEMPERATURE: see wire type
 OPERATING FORCE: 200 grams.

Materials

CASE: Nylon
 COVER: PBT
 ACTUATOR: PBT
 MOVABLE CONTACTS: Silver alloy.
 TERMINALS: Brass.
 LEVER: Stainless steel
 WIRE: PVC+CU

NOTE: Specifications and materials listed above are for switches with standard options. For information on specific and custom switches, consult Customer Service Center.

Snap-acting

Build-A-Switch

To order, simply select desired option from each category and place in the appropriate box. Available options are shown and described on pages J-17 thru J-19. For additional options not shown in catalog, consult Customer Service Center.

Electrical Rating
see chart below

Operating Force
S 200 grams
D 50 grams
J 100 grams
L 150 grams
H 300 grams

Actuator Lever Fixed
P00 Button
T10 Lever - high force
T20 Lever - low force
A05 Lever roller - High force, short lever
A10 Lever roller - high force
A20 Lever roller - low force
A25 Lever roller - Low force, short lever

Circuit Arrangement
C SPDT
Y SPST N.O.
W SPST N.C.

Terminal Type
W Wire

Wire Type
C 16 AWG
D 18 AWG
E 20 AWG
F 22 AWG
G 24 AWG
H 26 AWG

OPERATING TEMPERATURE
 -40°C to + 85°C (with UL1015 wire)

Wire UL #
B UL1015 (T55)

Mounting Hole Size
NONE 3.1 mm (3 mm screw clearance hole)
S 2.9 mm (4-40 screw clearance hole)

| ELECTRICAL RATING | AMPS | WIRE TYPE | | | | |
|-------------------|------|-----------|---------|---------|---------|--------------------|
| | | C 16AWG | D 18AWG | E 20AWG | F 22AWG | G 24AWG H 26AWG |
| 01 | 0.1 | • | • | • | • | • |
| 03 | 3 | • | • | • | X | X |
| 06 | 6 | • | • | X | X | X |
| 10 | 10 | • | X | X | X | X |

• Available
 X Not available



Dimensions are shown: mm
 Specifications and dimensions subject to change

TFS Series Sealed Miniature Snap-acting Switches (Water Proof)

SERIES

TFS SUB-MINIATURE SNAP-ACTING SWITCHES – WATERPROOF

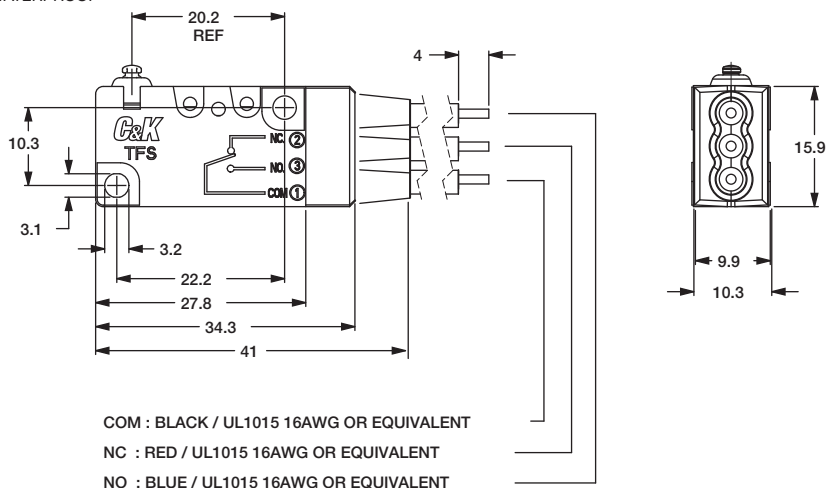

ELECTRICAL RATING

| OPTION CODE | RoHS COMPLIANT | RoHS COMPATIBLE | ELECTRICAL RATING |
|-------------|----------------|-----------------|--|
| 10 | Yes | Yes | 10A @ 125/250 V AC / 10,000 operations |
| 06 | Yes | Yes | 6A @ 125/250 VAC / 10,000 operations |
| 03 | Yes | Yes | 3A @ 125/250 VAC / 10,000 operations |
| 01 | Yes | Yes | 0.1A @ 125/250 VAC / 10,000 operations |

OPERATING FORCE

| OPTION CODE | BASIC SWITCH OPERATING FORCE |
|-------------|------------------------------|
| S | 200 GRAMS |
| D | 50 grams |
| J | 100 grams |
| L | 150 grams |
| H | 300 grams |



Snap-acting

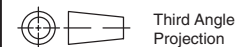

Third Angle Projection

Dimensions are shown: mm
Specifications and dimensions subject to change

TFS Series Sealed Miniature Snap-acting Switches (Water Proof)

ACTUATOR

P00 BUTTON

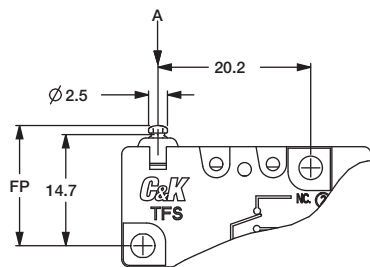

Measure at Point "A"

| | |
|----------------------------|---------------|
| Max. operating force | 200 grams |
| Min. release force | 30 grams |
| Operating position OP | 14.7 ± 0.4 mm |
| Max. movement differential | 0.4 mm |
| Min. over travel OT | 1.0 mm |
| Max. pre-travel PT | 1.2 mm |

T10 LEVER, HIGH FORCE

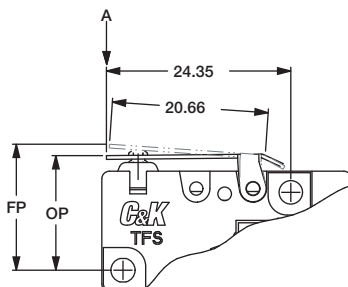

Measure at Point "A"

| | |
|----------------------------|---------------|
| Max. operating force | 160 grams |
| Min. release force | 25 grams |
| Operating position OP | 15.1 ± 0.6 mm |
| Max. movement differential | 0.6 mm |
| Min. over travel OT | 1.1 mm |
| Max. pre-travel PT | 2.6 mm |

T20 LEVER, LOW FORCE

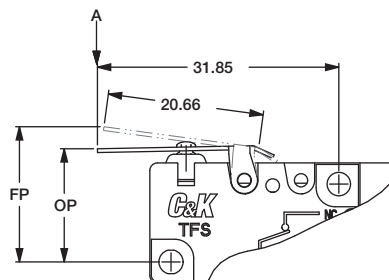

Measure at Point "A"

| | |
|----------------------------|-------------|
| Max. operating force | 90 grams |
| Min. release force | 10 grams |
| Operating position OP | 15 ± 1.1 mm |
| Max. movement differential | 1.1 mm |
| Min. over travel OT | 1.2 mm |
| Max. pre-travel PT | 5.1 mm |

A05 LEVER ROLLER
HIGH FORCE, SHORT LEVER

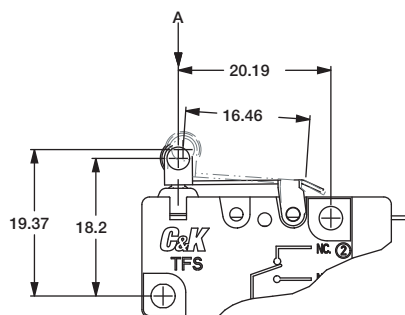

Measure at Point "A"

| | |
|----------------------------|---------------|
| Max. operating force | 200 grams |
| Min. release force | 30 grams |
| Operating position OP | 20.6 ± 0.5 mm |
| Max. movement differential | 0.5 mm |
| Min. over travel OT | 1.0 mm |
| Max. pre-travel PT | 2.1 mm |

A10 LEVER ROLLER
HIGH FORCE

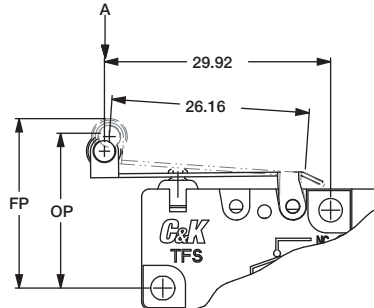

Measure at Point "A"

| | |
|----------------------------|---------------|
| Max. operating force | 130 grams |
| Min. release force | 20 grams |
| Operating position OP | 20.4 ± 0.7 mm |
| Max. movement differential | 0.7 mm |
| Min. over travel OT | 1.3 mm |
| Max. pre-travel PT | 3.3 mm |

A20 LEVER ROLLER
LOW FORCE

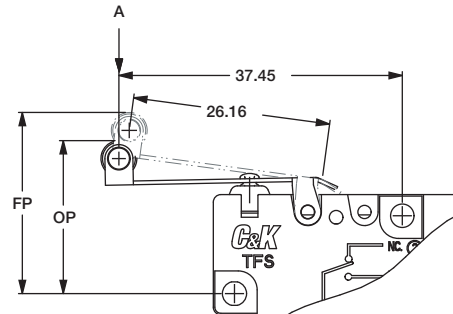

Measure at Point "A"

| | |
|----------------------------|---------------|
| Max. operating force | 70 grams |
| Min. release force | 10 grams |
| Operating position OP | 20.2 ± 1.2 mm |
| Max. movement differential | 1.4 mm |
| Min. over travel OT | 1.5 mm |
| Max. pre-travel PT | 6.5 mm |

Snap-acting

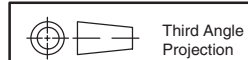

Third Angle
Projection

Dimensions are shown: (mm)
Specifications and dimensions subject to change



TFS Series Sealed Miniature Snap-acting Switches (Water Proof)

ACTUATOR

A25 LEVER ROLLER
LOW FORCE, SHORT LEVER

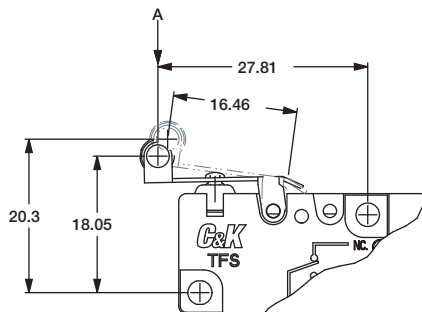

Measure at Point "A"

| | |
|----------------------------|---------------|
| Max. operating force | 150 grams |
| Min. release force | 15 grams |
| Operating position OP | 20.4 ± 0.9 mm |
| Max. movement differential | 0.9 mm |
| Min. over travel OT | 1.2 mm |
| Max. pre-travel PT | 4.2 mm |

TERMINAL TYPE

W WIRE UL1015

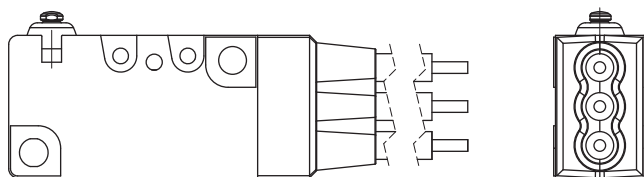

Snap-acting

CIRCUITRY

- C** SPDT (Single Pole, Double Throw)
- Y** SPST N.O. (Single Pole, Single Throw, Normally Open)
- W** SPST N.C. (Single Pole, Single Throw, Normally Closed)

WIRE TYPE

- C** 16 AWG
- D** 18 AWG
- E** 20 AWG
- F** 22 AWG
- G** 24 AWG
- H** 26 AWG

MOUNTING HOLE SIZE

NONE 3.1 mm (3mm SCREW CLEARANCE HOLE)

S 2.9 mm (4-40 SCREW CLEARANCE HOLE)

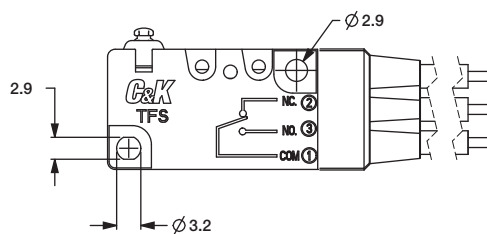
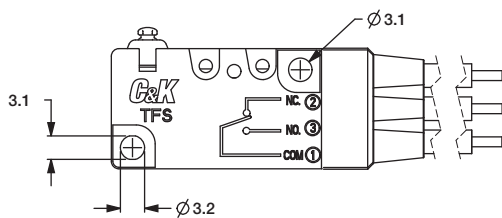

Third Angle Projection

Dimensions are shown: (mm)
Specifications and dimensions subject to change



TF2 Series Miniature Snap-acting Switches



Features/Benefits

- Broad range of operating forces
- Ratings up to 10 AMPS
- Wide variety of actuator styles
- Quick connect terminations

Typical Applications

- Motor controls
- Thermostatics
- Portable tools
- Air Conditioner



Specifications

CONTACT RATING: From low level* to 10 AMPS @125/250 V AC.
 ELECTRICAL LIFE: 10,000 cycles
 MECHANICAL LIFE: 1,000,000 cycles at 0.1A and 6A
 400,000 cycles at 10A
 INSULATION RESISTANCE: 1,000 M ohm min.
 DIELECTRIC STRENGTH: 1,500 Vrms min. @ sea level.
 OPERATING TEMPERATURE: -40°C to 125°C (-40°C to 85°C).
 OPERATING FORCE: From 18 to 330 grams at actuator button available.
 MOUNTING: Torque screws 2-5 in/lbs.

* Low Level=conditions where no arcing occurs during switching, i.e., 0.4 VA max. @ 20 V AC or DC max. Standard electrical life per UL 1054, rated for 6,000 operations.

Materials

SWITCH HOUSING: Nylon 6/6
 ACTUATOR BUTTON: Nylon 6/6
 SPRING: Stainless Steel
 PIVOT: Brass Alloy
 MOVABLE CONTACTS: See electric rating page J-21
 MOVABLE BLADE: BeCu
 STATIONARY CONTACTS: See electric rating page J-21
 TERMINALS: Brass Alloy

NOTE: Specifications and materials listed above are switches with standard options. For information on specific and custom switches, consult Customer Service Center.



Snap-acting

Build-A-Switch

To order, simply select desired option from each category and place in the appropriate box. Available options are shown and described on pages J-21 through J-25. For additional options not shown in catalog, consult Customer Service Center.

Series **TF2** SP, Mom.

Operating Force
CC 18 grams
CF 45 grams
CG 75 grams
CH 110 grams
CJ 170 grams
EC 230 grams
EE 330 grams

Electrical Rating Chart

| OPTION CODE | UL US 61058-1 | ENEC 15 |
|-------------|---|-----------------------------------|
| F5 | 0.1A 125/250 V AC (T85) Min. 10,000 operations | 0.1A 125/250 V AC μT125, 1E4 |
| H8 | 6A 125/250 V AC (T85) Min. 10,000 operations | 6A 125/250 V AC μT125, 1E4 |
| K6 | 10A 125/250 V AC (T85) Min. 10,000 operations | 10(4)A 125/250 V AC μT125, 1E4 |

Mounting Style
S Standard
V Metric

Actuator
P00 Pin plunger
A10 Lever roller 12.5 mm
A15 Lever roller 25.9 mm
A20 Lever roller 12.5 mm
A25 Lever roller 25.9 mm
T10 Lever 14 mm
T14 Simulated roller 24.5 mm
T15 Lever 27.5 mm
T16 Lever 31.7 mm
T17 Lever 35 mm
T20 Lever 14 mm
T24 Simulated lever 24.5 mm
T25 Lever 27.5 mm
T26 Lever 31.7 mm
T27 Lever 35 mm

Circuitry
C SPDT
W SPST N.C.
Y SPST N.O.

* Note: No UL & ENEC 15 safety for Termination option "60"

Terminations
40 .187" quick connect
4A .250" quick connect
5A .250" off set quick connect
5B .187" off set quick connect
60 Screw style *
10 Solder

see chart on following pages for detailed information



Dimensions are shown: mm
 Specifications and dimensions subject to change

TF2 Series Miniature Snap-acting Switches

SERIES

TF2 MINIATURE SNAP-ACTING SWITCHES

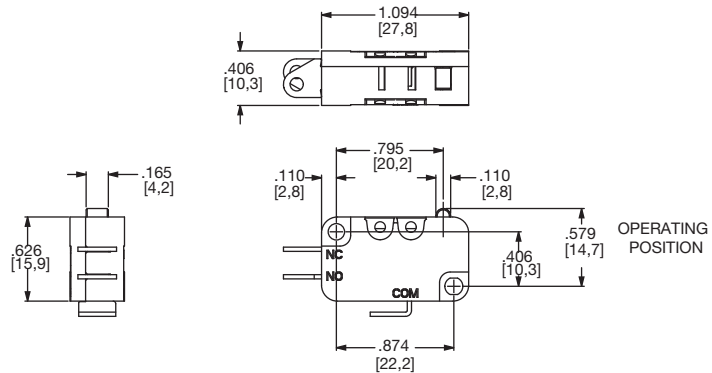

OPERATING FORCE

| OPTION CODE | BASIC SWITCH OPERATING FORCE (grams) |
|-------------|--------------------------------------|
| CC | 18 |
| CF | 45 |
| CG | 75 |
| CH | 110 |
| CJ | 170 |
| EC | 230 |
| EE* | 330 |

*Minimums may apply, consult Customer Service Center.

ELECTRICAL RATING

| OPTION CODE | CONTACT MATERIAL | | MOVABLE CONTACT | STATIONARY CONTACT |
|-------------|------------------|-------------------|-----------------|--------------------|
| | RoHS COMPLIANT * | RoHS COMPATIBLE * | | |
| F5 | Yes | Yes | Silver alloy | Silver alloy |
| H8 | Yes | Yes | | |
| K6 | Yes | Yes | | |

* Note: See Technical Data section of this catalog for RoHS compliant and compatible definitions and specifications.

All models  



Dimensions are shown: inches (mm)
Specifications and dimensions subject to change

www.ck-components.com



TF2 Series Miniature Snap-acting Switches

ELECTRICAL RATING

| INTERNATIONAL RATING SYMBOLS | |
|------------------------------|--|
| μ | Microgap construction (less than 3 mm). |
| ~ | Alternating current. |
| T__ | Maximum rated use temperature. |
| 50E3 | Cycles over 50,000 at rated current. |
| 10E3 | Cycles over 10,000 at rated current. |
| 10(3) | Current Rating: First number represents resistive rating; second number represents inductive (motor) rating. |

| ELECTRICAL RATING | AMPS (REF.) | OPERATING FORCE | | | | | | |
|-------------------|-------------|-----------------|---------|---------|----------|----------|----------|----------|
| | | CC (18) | CF (45) | CG (75) | CH (110) | CJ (170) | EC (230) | EE (330) |
| F5 | 0.1 | • | • | • | • | • | • | X |
| H8 | 6 | X | • | • | • | • | • | • |
| K6 | 10 | X | X | X | • | • | • | • |

• AVAILABLE
X NOT AVAILABLE



Snap-acting

All models

Consult Customer Service center for availability and delivery of nonstandard ratings.

* Low Level=conditions where no arcing occurs during switching, i.e., 0.4 VA max. @ 20 V AC or DC max.

MOUNTING STYLE

S STANDARD
For 4-40 screw size

V Metric
For 3 mm screw size

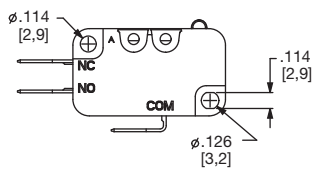

TF2 SWITCH WITH TYPE 40 (.187 QC) TERMINALS AND P00 ACTUATOR SHOWN

NOTE: TORQUE MOUNTING SCREWS 2-5 IN/LBS.

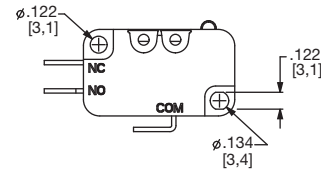

TF2 SWITCH WITH TYPE 10 (SOLDER) TERMINALS AND P00 ACTUATOR SHOWN

NOTE: TORQUE MOUNTING SCREWS 2-5 IN/LBS.

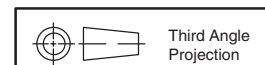

Dimensions are shown: inches (mm)
Specifications and dimensions subject to change

TF2 Series Miniature Snap-acting Switches

ACTUATOR

| OPTION CODE | FIG | DIM. A | DIM. B | DIM. C | DIM. D | DIM. E |
|-------------|-----|------------------|---------------|-------------------------------|-----------------|------------------|
| P00 | 2 | .795 (20,2) | - | .578 ± .019 (14,70 ± 0,05) | 0.068 (1,72) | - |
| A10 | 1 | .822 (20,9) | .33 (8,4) | .816 ± .050 (20,73 ± 1,27) | .106 (2,70) | ∅.19 (∅ 4,8) |
| A15 | 1 | 1.35 (34,3) | .33 (8,4) | .816 ± .059 (20,73 ± 1,5) | .165 (4,20) | ∅.19 (∅ 4,8) |
| A20 | 1 | 1.05 (26,8) | .56 (14,3) | .816 ± .050 (20,73 ± 1,27) | .183 (4,65) | ∅.19 (∅ 4,8) |
| A25 | 1 | 1.58 (40,2) | .56 (14,3) | .816 ± .086 (20,73 ± 2,2) | .366 (9,30) | ∅.19 (∅ 4,8) |
| T10 | 3 | .882 (22,39) | .33 (8,4) | .602 ± .020 (15,3 ± 0,50) | .110 (2,80) | - |
| T14 | 4 | 1.295 (32,9) | .33 (8,4) | .737 ± .059 (18,72 ± 1,5) | .216 (5,50) | ∅.275 (∅ 7,0) |
| T15 | 3 | 1.405 (35,69) | .33 (8,4) | .600 ± .059 (15,24 ± 1,5) | .232 (5,90) | - |
| T16 | 3 | 1.58 (40,01) | .33 (8,4) | .604 ± .068 (15,35 ± 1,75) | .196 (5,0) | - |
| T17 | 3 | 1.708 (43,39) | .33 (8,4) | .603 ± .062 (15,33 ± 1,57) | .216 (5,50) | - |
| T20 | 3 | 1.11 (28,3) | .56 (14,3) | .604 ± .045 (15,34 ± 1,14) | .204 (5,20) | - |
| T24 | 4 | 1.527 (38,8) | .56 (14,3) | .742 ± .090 (18,84 ± 2,29) | .342 (8,70) | ∅.275 (∅ 7,0) |
| T25 | 3 | 1.631 (41,43) | .56 (14,3) | .609 ± .090 (15,47 ± 2,3) | .381 (9,70) | - |
| T26 | 3 | 1.811 (46,00) | .56 (14,3) | .616 ± .125 (15,65 ± 3,18) | .389 (9,90) | - |
| T27 | 3 | 1.94 (49,3) | .56 (14,3) | .598 ± .150 (15,2 ± 3,8) | .433 (11,0) | - |

NOTE: Switch characteristics chart on following page.

Lever Roller

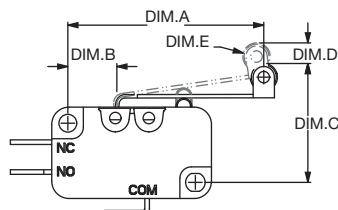

FIG. 1
LEVER ROLLER
TF2XXXXMA1510C

Pin Roller

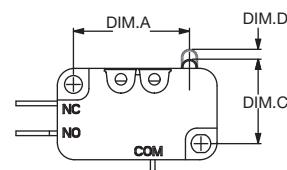

FIG. 2
PIN ROLLER
TF2XXXXMP0010C

Lever

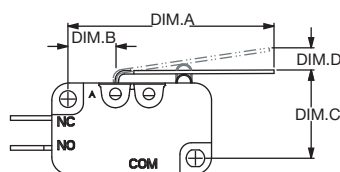

FIG. 3
LEVER
TF2XXXXST1510C SHOWN

Simulated Roller

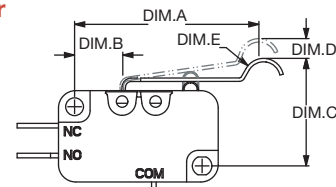

FIG. 4
SIMULATED ROLLER
TF2XXXXST1410C



Third Angle
Projection

Dimensions are shown: inches (mm)
Specifications and dimensions subject to change

C&K

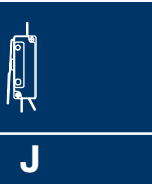

Snap-acting

TF2 Series Miniature Snap-acting Switches

ACTUATOR 

| Lever Type | | CC | CF | CG | CH Grams | CJ | EC | EE | Pre-Travel max. mm | Max Differential max. mm | Over Travel Min. mm |
|------------|----|----|----|----|-------------|-----|-----|-----|-----------------------|--------------------------------|------------------------|
| P00 | OF | 18 | 45 | 75 | 110 | 170 | 230 | 330 | 1.72 | 0.4 | 0.8 |
| | RF | 3 | 7 | 14 | 20 | 34 | 42 | 60 | | | |
| T10 | OF | 18 | 45 | 75 | 110 | 170 | 230 | 330 | 2.8 | 0.5 | 0.6 |
| | RF | - | 6 | 11 | 17 | 25 | 35 | 50 | | | |
| T20 | OF | 8 | 27 | 43 | 50 | 85 | 120 | 175 | 5.2 | 0.9 | 1.55 |
| | RF | - | 3 | 5 | 7 | 13 | 17 | 25 | | | |
| T14 | OF | 10 | 28 | 43 | 65 | 110 | 140 | 205 | 5.5 | 1.1 | 1.4 |
| | RF | - | 3 | 5 | 8 | 14 | 17 | 31 | | | |
| T24 | OF | 7 | 16 | 24 | 35 | 56 | 70 | 100 | 8.7 | 1.7 | 3.2 |
| | RF | - | - | - | 4 | 5 | 9 | 12 | | | |
| A10 | OF | 20 | 55 | 80 | 110 | 170 | 230 | 330 | 2.7 | 0.45 | 0.6 |
| | RF | - | 5 | 11 | 16 | 28 | 31 | 45 | | | |
| A20 | OF | 8 | 35 | 55 | 70 | 100 | 120 | 175 | 4.65 | 0.8 | 1.4 |
| | RF | - | 3 | 5 | 7 | 14 | 18 | 28 | | | |
| A15 | OF | 8 | 30 | 45 | 65 | 100 | 125 | 180 | 4.2 | 1.25 | 1.6 |
| | RF | - | - | 5 | 7 | 12 | 16 | 25 | | | |
| A25 | OF | 7 | 20 | 30 | 40 | 51 | 65 | 90 | 9.3 | 1.8 | 2.8 |
| | RF | - | - | - | - | 6 | 8 | 9 | | | |
| T17 | OF | 16 | 25 | 35 | 50 | 80 | 100 | 140 | 5.5 | 1.2 | 0.55 |
| | RF | - | 2 | 4 | 6 | 11 | 14 | 20 | | | |
| T27 | OF | 13 | 18 | 24 | 32 | 45 | 55 | 90 | 11 | 2.3 | 3.6 |
| | RF | - | - | 2 | 3 | 5 | 7 | 10 | | | |
| T16 | OF | 15 | 17 | 32 | 55 | 85 | 110 | 150 | 5 | 1.05 | 1.8 |
| | RF | - | - | 4 | 6 | 12 | 15 | 22 | | | |
| T26 | OF | 10 | 12 | 18 | 35 | 45 | 65 | 90 | 9.9 | 2.05 | 3.6 |
| | RF | - | - | 2 | 4 | 6 | 8 | 11 | | | |
| T15 | OF | 18 | 22 | 37 | 50 | 86 | 125 | 180 | 5.9 | 1 | 1.6 |
| | RF | - | 3 | 5 | 9 | 14 | 17 | 24 | | | |
| T25 | OF | 5 | 16 | 25 | 30 | 51 | 65 | 90 | 9.7 | 2.2 | 3.1 |
| | RF | - | - | 3 | 4 | 6 | 8 | 11 | | | |

HIGH FORCE, LOW MOTION PIVOT POSITION

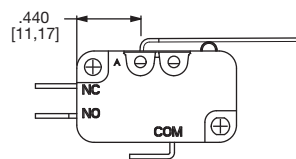

Available with actuators A10, A15, T10, T13, T14, T15, T16 and T18.

LOW FORCE, HIGH MOTION PIVOT POSITION

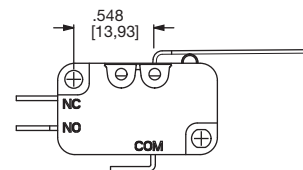

Available with actuators A20, A25, T20, T23, T24, T25, T26, and T28.

NOTE: Lever actuator options are available in either of two pivot positions. Levers located in the forward pivot position have lower forces and higher motions. Levers located in the rear pivot position have higher forces and lower motions.



Third Angle
Projection

Dimensions are shown: mm

Specifications and dimensions subject to change



TF2 Series Miniature Snap-acting Switches

TERMINATIONS

40 .187" QUICK CONNECT

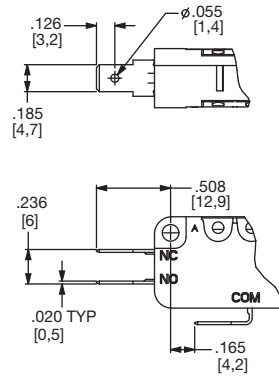

4A .250" QUICK CONNECT

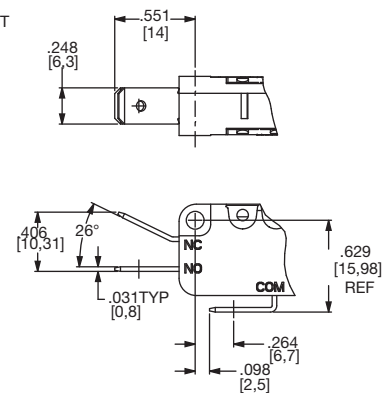

5A .250" OFF SET QUICK CONNECT

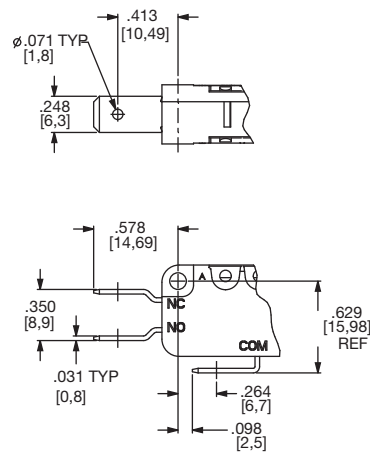

5B .187" OFF SET QUICK CONNECT

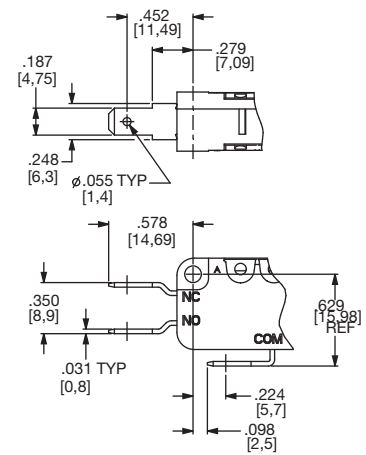

60 SCREW STYLE

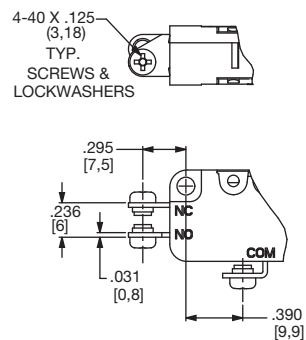

10 SOLDER

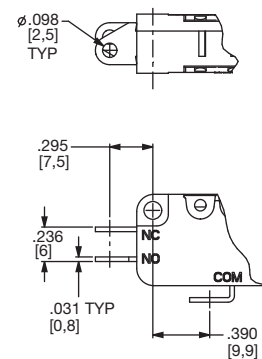

CIRCUITRY

- C** SPDT (Single Pole, Double Throw)
- W** SPST N.C. (Single Pole, Single Throw, Normally Closed)
- Y** SPST N.O. (Single Pole, Single Throw, Normally Open)



Third Angle
Projection

Dimensions are shown: inches (mm)
Specifications and dimensions subject to change

C&K



Snap-acting

TM Series Miniature Snap-acting Switches



Features/Benefits

- Broad range of operating forces available
- Wide variety of actuator and terminal styles
- Cost-effective solution

Typical Applications

- Pumps and motors
- White goods
- Consumer appliances



Specifications

CONTACT RATING: From low level* to 15 AMPS @ 250 V AC.
 ELECTRICAL LIFE: 150,000 cycles at 15 AMPS @ 250 V AC, models with 150 grams operating force. 350,000 cycles at 10 AMPS @ 250 V AC, models with 75 grams operating force.
 INSULATION RESISTANCE: 1,000 M ohms min.
 DIELECTRIC STRENGTH: 1,000 Vrms min. @ sea level.
 OPERATING TEMPERATURE: -67°F to 302°F (-55°C to 150°C).
 OPERATING FORCE: 50, 75 and 150 grams at actuator available; refer to chart for lever style forces.
 MOUNTING: Torque screws 2-5 in/lbs.

* Low Level=conditions where no arcing occurs during switching, i.e., 0.4 VA max. @ 20 V AC or DC max.

Materials

SWITCH HOUSING: Thermoplastic or general purpose phenolic (UL 94V-0).
 ACTUATOR BUTTON: Thermoplastic (UL 94V-0).
 SPRING: Copper alloy.
 PIVOT: Brass alloy.
 MOVABLE CONTACTS: Gold alloy for ratings 1 AMP @ 125 V AC or less. Fine silver for ratings greater than 1 AMP @ 125 V AC.
 STATIONARY CONTACTS: Gold alloy for ratings 1 AMP or less. Fine silver for ratings greater than 1 AMP.
 TERMINALS: Brass alloy for ratings up to 10 AMPS @ 250 V AC. Copper alloy for 15 AMPS @ 250 V AC ratings.

NOTE: Specifications and materials listed above are for switches with standard options. For information on specific and custom switches, consult Customer Service Center.



Snap-acting

Build-A-Switch

To order, simply select desired option from each category and place in the appropriate box. Available options are shown and described on pages J-26 through J-31. For additional options not shown in catalog, consult Customer Service Center. Available extended electrical life per UL 1054, rated for 100,000 operations, consult factory.

| | | | | | | | | |
|---|--|--|--|--|--|--|--|--|
| <div style="border: 1px solid black; padding: 5px; display: inline-block;"> T M </div> | | | | | | | | |
| Series | _____ | | | | | | | |
| TM | SP, Mom. | | | | | | | |
| Operating Force | _____ | | | | | | | |
| CG | 2.65 oz./75 grams | | | | | | | |
| CJ | 5.29 oz./150 grams | | | | | | | |
| CF | 1.76 oz./50 grams | | | | | | | |
| Electrical Rating | _____ | | | | | | | |
| D6 | 10 A @ 125 & 250 V AC; 1/3 HP @ 125 & 250 V AC; 1/2 A @ 125 V DC; 1/4 A @ 250 V DC | | | | | | | |
| G6 | 15 A @ 125 & 250 V AC; 1/4 A @ 250 V DC; 1/2 A @ 125 V DC; 1/2 HP @ 125 & 250 V AC; 3 A @ 125 V AC "L" | | | | | | | |
| F5 | 1 A @ 125 V AC; 1 A @ 30 V DC | | | | | | | |
| H3 | 5 A @ 250 V AC; 1/6 HP @ 125 & 250 V AC | | | | | | | |
| Mounting Style | _____ | | | | | | | |
| S | Standard | | | | | | | |
| V | Metric | | | | | | | |
| Actuator | _____ | | | | | | | |
| P00 | Pin plunger | | | | | | | |
| A10 | .81" lever roller, high force | | | | | | | |
| A15 | 1.34" lever roller, high force | | | | | | | |
| A20 | 1.02" lever roller, low force | | | | | | | |
| A25 | 1.56" lever roller, low force | | | | | | | |
| T10 | .84" lever, high force | | | | | | | |
| T13 | 1.34" simulated roller, high force | | | | | | | |
| T14 | 1.29" simulated roller, high force | | | | | | | |
| T15 | 1.40" lever, high force | | | | | | | |
| T16 | 2.34" lever, high force | | | | | | | |
| T17 | 2.00" lever, high force | | | | | | | |
| T18 | 2.75" lever, high force | | | | | | | |
| T20 | 1.06" lever, low force | | | | | | | |
| T23 | 1.56" simulated roller, low force | | | | | | | |
| T24 | 1.50" simulated roller, low force | | | | | | | |
| T25 | 1.62" lever, low force | | | | | | | |
| T26 | 2.56" lever, low force | | | | | | | |
| T27 | 2.22" lever, low force | | | | | | | |
| T28 | 2.97" lever, low force | | | | | | | |
| Terminations | _____ | | | | | | | |
| 40 | .187" quick connect | | | | | | | |
| 10 | Solder | | | | | | | |
| 4A | .250" quick connect | | | | | | | |
| 60 | Screw | | | | | | | |
| Circuitry | _____ | | | | | | | |
| C | SPDT | | | | | | | |
| W | SPST N.C. | | | | | | | |
| Y | SPST N.O. | | | | | | | |

* All models



Dimensions are shown: Inch (mm)

Specifications and dimensions subject to change

TM Series Miniature Snap-acting Switches

SERIES

TM MINIATURE SNAP-ACTING SWITCHES – SP MOMENTARY

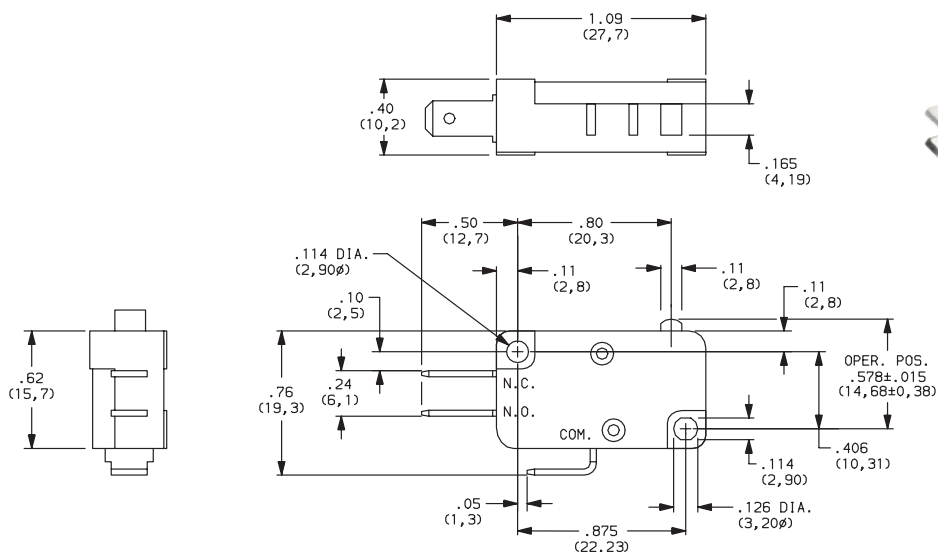

OPERATING FORCE

| OPTION CODE | BASIC SWITCH OPERATING FORCE (OZ./GRAMS) |
|-------------|--|
| CG | 2.65 75 |
| CJ | 5.29 150 |
| CF | 1.76 50 |

Operating Force option 'CF' not available with 'T18, T27 and T28' actuator options. Operating force varies with actuator option, see ACTUATOR option section.

ELECTRICAL RATING

| OPTION CODE | RoHS COMPLIANT* | RoHS COMPATIBLE* | CONTACT MATERIAL | | ELECTRICAL RATING |
|-------------|--------------------|---------------------|--------------------|-----------------------|--|
| | | | MOVABLE CONTACT | STATIONARY CONTACT | |
| D6 | Yes | Yes | Fine Silver | Fine Silver | 10 AMPS @ 125 & 250 V AC; 1/3 HP @ 125 & 250 V AC; 1/2 AMP @ 125 V DC; 1/4 AMP @ 250 V DC. |
| F5 | Yes | Yes | Gold alloy | Gold alloy | From low level* to 1 AMP @ 125 V AC, 1 AMP @ 30 V DC. |
| G6 | Yes | Yes | Fine Silver | Fine Silver | 15 AMPS @ 125 & 250 V AC; 0.25 AMP @ 250 V DC; 0.5 AMP @ 125 V DC; 1/2 HP @ 125 & 250 V AC; 3 AMPS @ 125 V AC "L". |
| H3 | Yes | Yes | | | 5 AMPS @ 250 V AC; 1/6 HP @ 125 & 250 V AC. |

* Note: See Technical Data section of this catalog for RoHS compliant and compatible definitions and specifications.

* All models us

Contact Customer Service Center for availability and delivery of nonstandard ratings.

* Low Level=conditions where no arcing occurs during switching, i.e., 0.4 VA max. @ 20 V AC or DC max.



Third Angle
Projection

Dimensions are shown: Inches (mm)
Specifications and dimensions subject to change



Snap-acting

TM Series Miniature Snap-acting Switches

ELECTRICAL RATING

AVAILABLE COMBINATIONS

| ELECTRICAL RATING | MAXIMUM OPERATING FORCE (OZ./GRAMS) | | |
|-------------------|-------------------------------------|---------------|----------------|
| | 1.76/50 CF | 2.65/75 CG | 5.29/150 CJ |
| D6 | • | • | • |
| F5 | • | • | • |
| G6 | X | X | • |
| H3 | • | • | • |

• AVAILABLE
X NOT AVAILABLE



* All models US

Contact Customer Service Center for availability and delivery of nonstandard ratings.

* Low Level=conditions where no arcing occurs during switching, i.e., 0.4 VA max. @ 20 V AC or DC max.

MOUNTING STYLE

Snap-acting

S Standard

V Metric

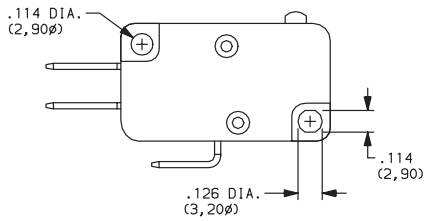

Recommended maximum screw size: 4-40.

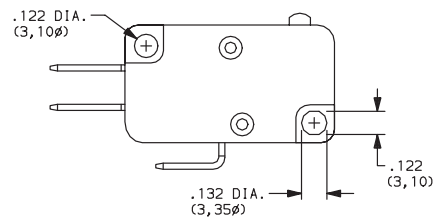

Recommended maximum screw size: 3 mm.

NOTE: Torque mounting screws 2-5 in/lbs.



Dimensions are shown: Inch (mm)
Specifications and dimensions subject to change

TM Series Miniature Snap-acting Switches

ACTUATOR

| OPTION CODE | FIG. | DIM. A | DIM. B | DIM. C | DIM. D |
|-------------|------|----------------|---------------|-------------------------------|---------------------|
| P00 | 2 | .80 (20,3) | — | .578 ± .015 (14,68 ± 0,38) | — |
| A10 | 1 | .81 (20,6) | .36 (9,1) | .810 ± .020 (20,57 ± 0,51) | .19 dia. (4,80) |
| A15 | 1 | 1.34 (34,0) | .36 (9,1) | .810 ± .040 (20,57 ± 1,02) | .19 dia. (4,80) |
| A20 | 1 | 1.03 (26,2) | .58 (14,7) | .810 ± .050 (20,57 ± 1,27) | .19 dia. (4,80) |
| A25 | 1 | 1.56 (39,6) | .58 (14,7) | .810 ± .080 (20,57 ± 2,03) | .19 dia. (4,80) |
| T10 | 3 | .84 (21,3) | .36 (9,1) | .600 ± .020 (15,24 ± 0,51) | — |
| T13 | 4 | 1.34 (34,0) | .36 (9,1) | .810 ± .040 (20,57 ± 1,02) | .19 dia. (4,80) |
| T14 | 4 | 1.28 (32,5) | .36 (9,1) | .743 ± .050 (18,9 ± 1,3) | .236 dia. (6,00) |
| T15 | 3 | 1.40 (35,6) | .36 (9,1) | .600 ± .040 (15,24 ± 1,02) | — |
| T16 | 3 | 2.34 (59,4) | .36 (9,1) | .600 ± .062 (15,24 ± 1,57) | — |
| T17 | 3 | 2.00 (50,8) | .36 (9,1) | .600 ± .052 (15,24 ± 1,33) | — |
| T18 | 3 | 2.75 (69,9) | .36 (9,1) | .600 ± .093 (15,24 ± 2,36) | — |
| T20 | 3 | 1.06 (26,9) | .58 (14,7) | .600 ± .045 (15,24 ± 1,14) | — |
| T23 | 4 | 1.56 (39,6) | .58 (14,7) | .810 ± .065 (20,57 ± 1,65) | .19 dia. (4,80) |
| T24 | 4 | 1.50 (38,1) | .58 (14,7) | .743 ± .090 (18,80 ± 2,29) | .236 dia. (6,00) |
| T25 | 3 | 1.62 (41,1) | .58 (14,7) | .600 ± .080 (15,24 ± 2,03) | — |
| T26 | 3 | 2.56 (65,0) | .56 (14,7) | .600 ± .125 (15,24 ± 3,18) | — |
| T27 | 3 | 2.22 (56,4) | .58 (14,7) | .600 ± .125 (15,24 ± 3,18) | — |
| T28 | 3 | 2.97 (75,4) | .58 (14,7) | .600 ± .187 (15,24 ± 4,75) | — |

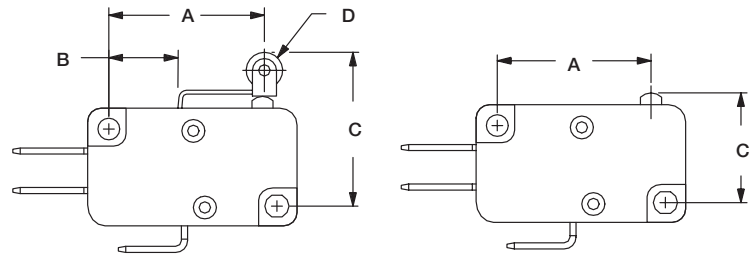

FIG. 1
Lever Roller

FIG. 2
Pin Roller

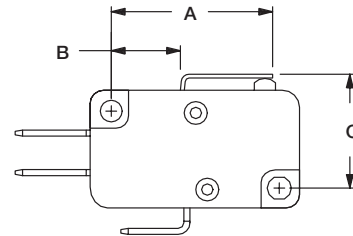

FIG. 3
Lever

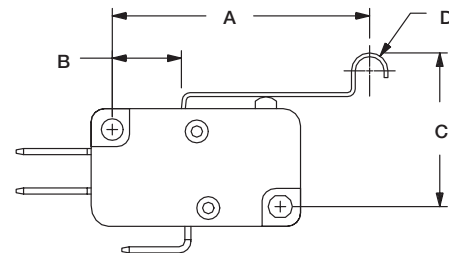
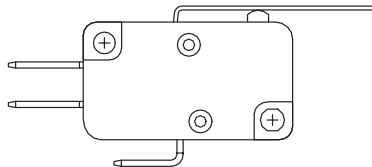

FIG. 4
Simulated Roller



Snap-acting

HIGH FORCE, LOW MOTION PIVOT POSITION



Available with actuators A10, A15, T10, T13, T14, T15, T16, T17 and T18.

LOW FORCE, HIGH MOTION PIVOT POSITION

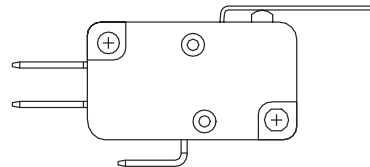

Available with actuators A20, A25, T20, T23, T24, T25, T26, T27 and T28.

NOTE: Lever actuator options are available in either of two pivot positions.
Levers located in the forward pivot position have lower forces and higher motions.
Levers located in the rear pivot position have higher forces and lower motions.

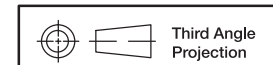

Dimensions are shown: Inches (mm)
Specifications and dimensions subject to change

TM Series Miniature Snap-acting Switches

ACTUATOR ■■■■■■

SWITCH CHARACTERISTICS

| OPTION CODE | MAXIMUM OPERATING FORCE (OZ./GRAMS) | | | MINIMUM RELEASE FORCE (OZ./GRAMS) | | | MINIMUM RETURN FORCE (OZ./GRAMS) | | | MAXIMUM DIFFERENTIAL TRAVEL | MAXIMUM PRETRAVEL | MINIMUM OVERTRAVEL |
|-------------|-------------------------------------|------------|-------------|-----------------------------------|-----------|------------|----------------------------------|-----------|------------|-----------------------------|-------------------|--------------------|
| | CF (50) | CG (75) | CJ (150) | CF (50) | CG (75) | CJ (150) | CF (50) | CG (75) | CJ (150) | ALL FORCES | ALL FORCES | ALL FORCES |
| T10 | 2.12 60 | 3.17 90 | 6.35 180 | .49 14 | .99 28 | 1.69 48 | .25 7 | .53 15 | 1.06 30 | .013 (0,33) | .080 (2,03) | .035 (0,89) |
| T13 | 1.06 30 | 1.59 45 | 2.82 80 | .21 6 | .35 10 | .71 20 | .11 3 | .14 4 | .35 10 | .030 (0,76) | .160 (4,06) | .065 (1,65) |
| T13 | 1.06 30 | 1.76 50 | 3.17 90 | .25 7 | .35 10 | .71 20 | .11 3 | .14 4 | .35 10 | .050 (1,27) | .140 (3,56) | .062 (1,57) |
| T15 | 1.06 30 | 1.59 45 | 2.28 80 | .21 6 | .32 9 | .71 20 | .11 3 | .14 4 | .35 10 | .032 (0,81) | .160 (4,06) | .075 (1,90) |
| T16 | .53 15 | .71 20 | 1.41 40 | .11 3 | .18 5 | .35 10 | .05 1.5 | .07 2 | .18 5 | .090 (2,29) | .312 (7,92) | .140 (3,56) |
| T17 | .71 20 | .88 25 | 1.76 50 | .14 4 | .21 6 | .42 12 | .07 2 | .07 2 | .21 6 | .062 (1,57) | .220 (5,59) | .110 (2,79) |
| T18 | N/A | .71 20 | 1.23 35 | N/A | .14 4 | .28 8 | N/A | .04 1 | .14 4 | .078 (1,98) | .375 (9,52) | .160 (4,06) |
| T20 | 1.06 30 | 1.59 45 | 3.17 90 | .21 6 | .32 9 | .71 20 | .11 3 | .18 5 | .35 10 | .030 (0,76) | .160 (4,06) | .065 (1,65) |
| T23 | .53 15 | 1.06 30 | 1.59 45 | .11 3 | .18 5 | .35 10 | .04 1 | .07 2 | .18 5 | .070 (1,78) | .312 (7,92) | .125 (3,18) |
| T24 | .53 15 | 1.23 35 | 1.76 50 | .11 3 | .18 5 | .35 10 | .05 1.5 | .07 2 | .18 5 | .080 (2,03) | .312 (7,92) | .110 (2,79) |
| T25 | .71 20 | 1.06 30 | 1.41 40 | .07 2 | .14 4 | .32 9 | .04 1 | .07 2 | .16 4.5 | .070 (1,78) | .330 (8,38) | .100 (2,54) |
| T26 | N/A | .35 10 | .71 20 | N/A | .07 2 | .18 5 | N/A | .04 1 | .07 2 | .110 (2,79) | .500 (12,7) | .250 (6,35) |
| T27 | N/A | .60 17 | .88 25 | N/A | .11 3 | .21 6 | N/A | .04 1 | .11 3 | .125 (3,18) | .500 (12,70) | .200 (5,08) |
| T28 | N/A | .42 12 | .63 18 | N/A | .07 2 | .14 4 | N/A | .04 1 | .07 2 | .187 (4,75) | .750 (19,05) | .280 (7,11) |
| A10 | 2.12 60 | 3.17 90 | 6.35 180 | .49 14 | .99 28 | 1.69 48 | .25 7 | .53 15 | 1.06 30 | .013 (0,33) | .070 (1,78) | .035 (0,89) |
| A15 | 1.06 30 | 1.59 45 | 2.82 80 | .21 6 | .35 10 | .71 20 | .11 3 | .14 4 | .35 10 | .030 (0,76) | .160 (4,06) | .065 (1,65) |
| A20 | 1.06 30 | 1.76 50 | 3.17 90 | .25 7 | .35 10 | .71 20 | .11 3 | .18 5 | .35 10 | .025 (0,64) | .140 (3,56) | .060 (1,52) |
| A25 | .53 15 | 1.06 30 | 1.59 45 | .11 3 | .18 5 | .35 10 | .04 1 | .07 2 | .18 5 | .070 (1,78) | .312 (7,92) | .125 (3,18) |
| P00 | 1.76 50 | 2.65 75 | 5.29 150 | .71 20 | .99 28 | 2.12 60 | .35 10 | .53 15 | 1.06 30 | .013 (0,33) | .056 (1,42) | .035 (0,89) |

Snap-acting

NOTE: For basic switch operating forces, see page J-26.

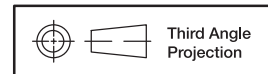

Dimensions are shown: Inch (mm)
Specifications and dimensions subject to change

TM Series Miniature Snap-acting Switches

TERMINATIONS

40 .187" QUICK CONNECT

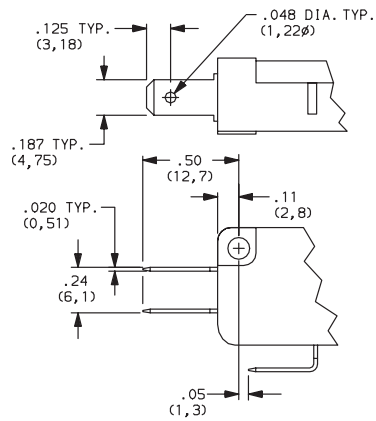

60 SCREW TERMINALS

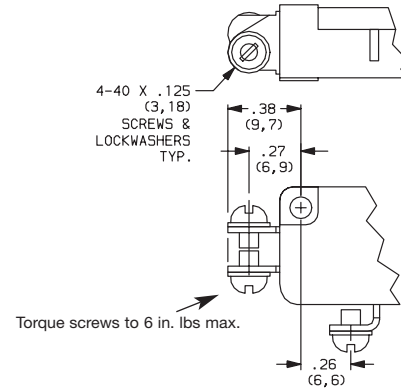

Not available with 'F5' rating option.

10 SOLDER

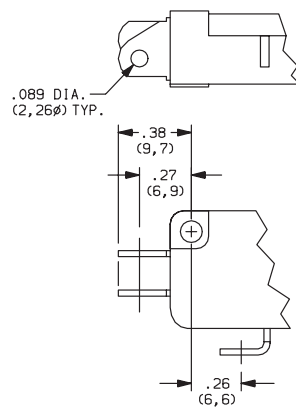

Not available with 'F5' rating option.

4A .250" QUICK CONNECT

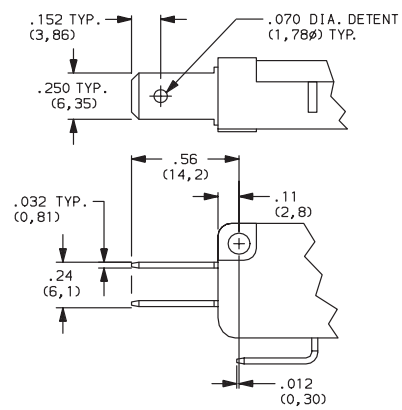

Not available with 'F5' rating option.

CIRCUITRY

- C** SPDT (Single Pole, Double Throw)
- W** SPST N.C. (Single Pole, Single Throw, Normally Closed)
- Y** SPST N.O. (Single Pole, Single Throw, Normally Open)

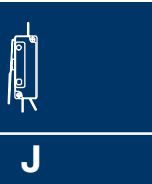

Snap-acting



Dimensions are shown: Inches (mm)
Specifications and dimensions subject to change

LC Series Subminiature Precision Snap-acting Switches



Features/Benefits

- Compact design
- Long life and high electrical capacity
- Quick connect, wire lead or PC mounting
- Wide variety of actuator styles

Typical Applications

- Motorized equipment
- Sump pump
- Thermostatic controls

UL61058-1  

Specifications

CONTACT RATING: From low level* to 10.1 AMPS @ 250 V AC.
 ELECTRICAL LIFE: 100,000 cycles
 INSULATION RESISTANCE: 1,000 M Ω min.
 DIELECTRIC STRENGTH: 1,000 Vrms min. @ sea level.
 OPERATING TEMPERATURE: -17°F to 185°F (-25°C to 85°C).
 OPERATING FORCE: From 142 to 170 grams at actuator button.
 Forces are less at free end of lever actuators; (see OPERATING FORCE and ACTUATOR option sections).
 MOUNTING: 2-56 screws, torque 2.3 in/lbs max.

* Low Level=conditions where no arcing occurs during switching, i.e., 0.4 VA max. @ 20 V AC or DC max.

NOTE: Specifications and materials listed above are for switches with standard options. For information on specific and custom switches, consult Customer Service center.

Materials

SWITCH HOUSING: Thermoplastic polyester or high temperature thermoplastic (PTS) (UL 94V-0).
 ACTUATOR BUTTON: Thermoplastic polyester (UL 94V-0).
 SPRING: Copper alloy.
 PIVOT: Copper alloy.
 MOVABLE CONTACTS: Fine silver for ratings greater than 1 AMP @ 125 V AC. Fine silver with 24K gold plate for 1 AMP @ 125 V AC or less.
 STATIONARY CONTACTS: Fine silver welded on copper alloy for ratings greater than 1 AMP @ 125 V AC. Gold alloy welded on copper alloy for ratings less than 1 AMP @ 125 V AC.
 TERMINALS: Copper alloy.
 TERMINAL SEAL: Epoxy.



Snap-acting

Build-A-Switch

To order, simply select desired option from each category and place in the appropriate box. Available options are shown and described on pages J-33 through J-35. For additional options not shown in catalog, consult Customer Service Center.

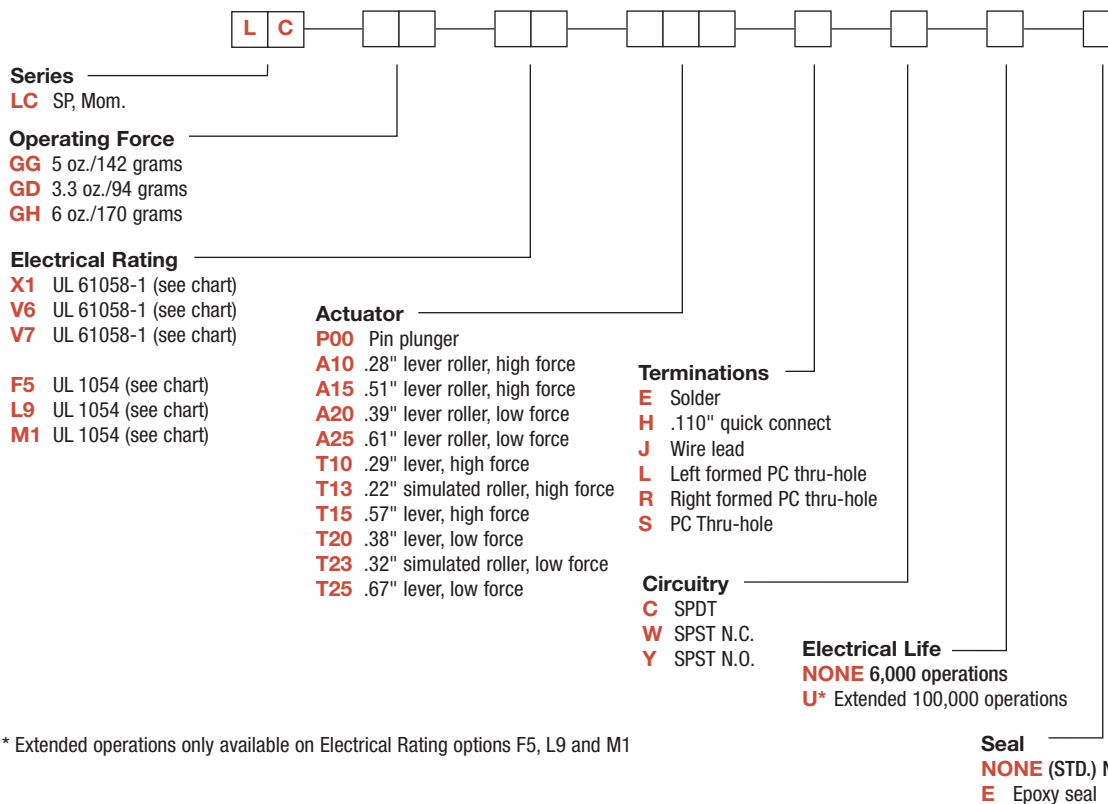

* Extended operations only available on Electrical Rating options F5, L9 and M1



Dimensions are shown: Inch (mm)
 Specifications and dimensions subject to change

LC Series Subminiature Precision Snap-acting Switches

SERIES

LC SUBMINIATURE PRECISION SNAP-ACTING SWITCHES
SP MOMENTARY

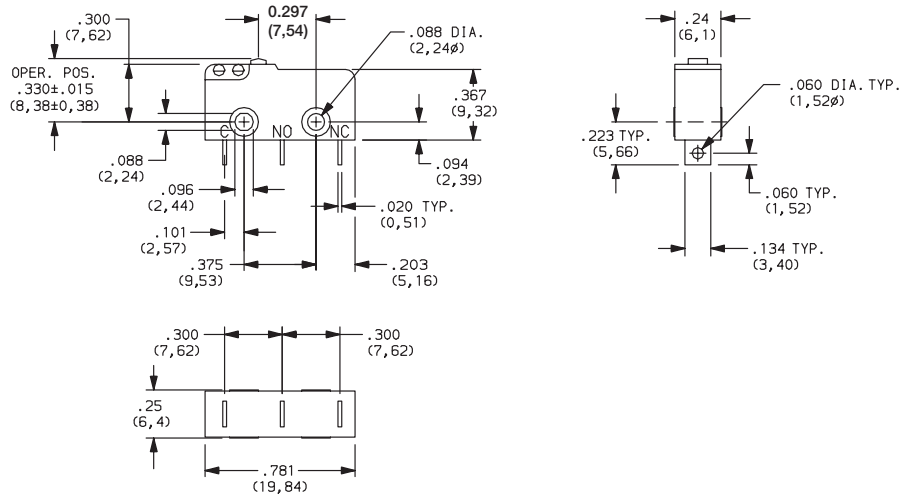

OPERATING FORCE

| OPTION CODE | BASIC SWITCH OPERATING FORCES (OZ./GRAMS) |
|-------------|---|
| GG | 5 142 |
| GD | 3.3 94 |
| GH | 6 170 |

NOTE: Operating force varies with actuator option, see ACTUATOR option section.

ELECTRICAL RATING

| OPTION CODE | ELECTRICAL RATING | CONTACT MATERIAL | | RoHS COMPLIANT* | RoHS COMPATIBLE* |
|-------------|--|---------------------------------|--|-----------------|------------------|
| | | MOVABLE CONTACT | STATIONARY CONTACT | | |
| X1 | 1A GP, 250 Vac, 50/60 Hz, 25E3, T85 1RA, 30 Vdc, 1E4, T85 | Fine silver with 24K gold plate | Fine silver with 24K gold plate on copper base alloy | Yes | Yes |
| V6 | 5(2)A RM, 250 Vac, 50/60 Hz, 1E4, T85 5A GP, 250 Vac, 50/60 Hz, 1E4, T85 5RA, 30 Vdc, 1E4, T85 1/3 HP, 125/250 Vac, 50/60 Hz, 1E4, T85 | Fine silver | Fine silver welded on copper base alloy | Yes | Yes |
| V7 | 10(2)A RM, 250 Vac, 50/60 Hz, 1E4, T85 10A GP, 250 Vac, 50/60 Hz, 1E4, T85 10RA, 30 Vdc, 1E4, T85 1/3 HP, 125/250 Vac, 50/60 Hz, 1E4, T85 | Fine silver | Fine silver welded on copper base alloy | Yes | Yes |

| OPTION CODE | ELECTRICAL RATING | CONTACT MATERIAL | | RoHS COMPLIANT* | RoHS COMPATIBLE* |
|-------------|---|---------------------------------|--|-----------------|------------------|
| | | MOVABLE CONTACT | STATIONARY CONTACT | | |
| F5 | 1A, 125 V AC, 30 VDC 100,000 cycles ("U" option) | Fine silver with 24K gold plate | Fine silver with 24K gold plate on copper base alloy | Yes | Yes |
| L9 | 5A, 1/3 HP @ 125 and 250 V AC 100,000 cycles ("U" option) | Fine silver | Fine silver welded on copper base alloy | Yes | Yes |
| M1 | 10.1A, 1/3 HP @ 125 and 250 V AC 100,000 cycles ("U" option) | Fine silver | Fine silver welded on copper base alloy | Yes | Yes |



* Note: See Technical Data section of this catalog for RoHS compliant and compatible definition and specifications.
Consult Customer Service Center for availability and delivery of nonstandard ratings.
*Low Level = conditions where no arcing occurs during switching, i.e., 0.4 VA max. @ 20 V AC or DC max.



Third Angle Projection
Dimensions are shown: Inches (mm)
Specifications and dimensions subject to change



Snap-acting

LC Series Subminiature Precision Snap-acting Switches

ACTUATOR 

| OPTION CODE | FIG. | DIM. A | DIM. B | DIM. C |
|-------------|------|-----------------|-------------------------------|--------------------|
| P00 | 1 | 0.297 (7,6) | .330 ± .015 (8,38 ± 0,38) | — |
| A10 | 7 | 0.28 (7,1) | .570 ± .070 (14,48 ± 1,78) | .19 dia. (4,80) |
| A25 | 2 | 0.61 (15,5) | .570 ± .175 (14,22 ± 4,45) | .19 dia. (4,80) |
| T10 | 3 | 0.29 (7,4) | .340 ± .070 (8,64 ± 1,78) | — |
| T13 | 5 | 0.220 (5,3) | .455 ± .065 (11,56 ± 1,65) | — |
| T20 | 4 | 0.39 (9,9) | .340 ± .140 (8,64 ± 3,56) | — |
| T23 | 6 | 0.32 (8,1) | .455 ± .125 (11,56 ± 3,18) | — |
| T25 | 4 | 0.67 (17,0) | .340 ± .091 (8,64 ± 4,70) | — |
| A15 | 7 | 0.51 (13,0) | .560 ± .090 (14,22 ± 2,29) | .19 dia. (4,80) |
| A20 | 2 | 0.38 (9,7) | .560 ± .135 (14,22 ± 2,29) | .19 dia. (4,80) |
| T15 | 3 | 0.57 (14,51) | .340 ± .100 (8,64 ± 2,54) | — |

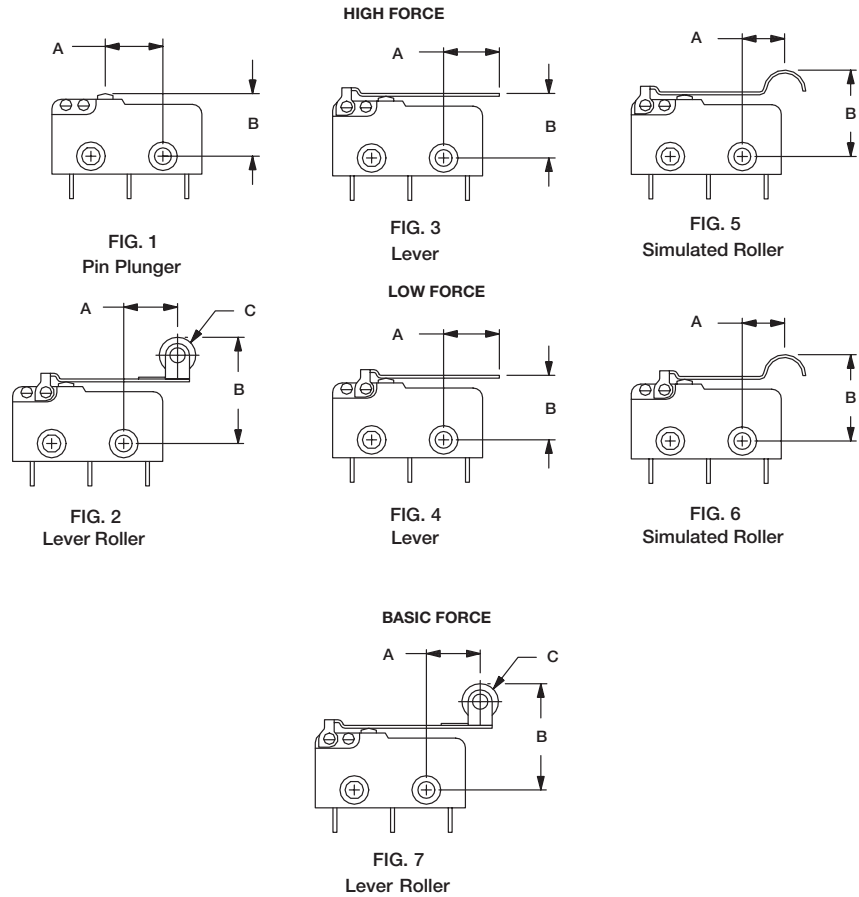

SWITCH CHARACTERISTICS

| OPTION CODE | MAXIMUM OPERATING FORCE (OZ./GRAMS) | | | MINIMUM RELEASE FORCE (OZ./GRAMS) | | | MAXIMUM DIFFERENTIAL TRAVEL | MAXIMUM PRETRAVEL | MINIMUM OVERTRAVEL |
|-------------|-------------------------------------|-----------|-----------|-----------------------------------|-----------|------------|-----------------------------|-------------------|--------------------|
| | GG | GD | GH | GG | GD | GH | ALL FORCES | ALL FORCES | ALL FORCES |
| A10 | 1.69 48 | 1 28 | 2.0 57 | .21 6 | .11 3 | .42 12 | .034 (0,86) | .140 (3,56) | .029 (0,74) |
| A15 | 1.3 37 | .68 19 | 1.6 44 | .16 4.5 | .07 2 | .32 9 | .044 (1,12) | .180 (4,57) | .037 (0,94) |
| A20 | 0.9 26 | .52 15 | 1.1 31 | .11 3 | .05 15 | .21 6 | .067 (1,70) | .272 (6,91) | .053 (1,53) |
| A25 | .70 20 | .42 12 | .85 24 | .07 2 | .04 1 | .16 4.5 | .086 (2,18) | .351 (8,92) | .068 (1,73) |
| P00 | 5 142 | 3.3 95 | 6 170 | 1 28 | .05 14 | 2.0 57 | .004 (0,10) | .030 (0,76) | .010 (0,25) |
| T10 | 1.7 48 | 1 28 | 2.1 60 | .21 6 | .10 3 | .39 11 | .035 (0,90) | .140 (3,56) | .029 (0,74) |
| T13 | 1.8 52 | 1.2 34 | 2.2 62 | .21 6 | .03 1 | .42 12 | .032 (0,81) | .130 (3,30) | .026 (0,66) |
| T20 | 0.9 26 | .52 15 | 1.1 30 | .10 3 | .03 1 | .21 6 | .067 (1,70) | .276 (7,01) | .053 (1,35) |
| T23 | 1.0 28 | .52 15 | 1.2 34 | .10 3 | .03 1 | .21 6 | .062 (1,57) | .252 (6,40) | .049 (1,24) |
| T25 | 0.7 19 | .05 14 | 0.8 24 | .07 2 | .03 1 | .14 4 | .090 (2,29) | .372 (9,45) | .072 (1,83) |
| T15 | 1.2 35 | 1.3 39 | 1.5 42 | 0.14 4 | .21 6 | .28 81 | .047 (1,19) | .190 (4,83) | .040 (1,02) |

NOTE: For basic switch operating forces, see page J-32.



Dimensions are shown: Inch (mm)
Specifications and dimensions subject to change



LC Series Subminiature Precision Snap-acting Switches

TERMINATIONS

E SOLDER

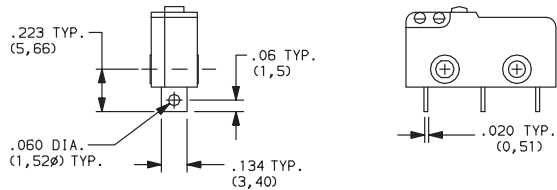

H .110" QUICK CONNECT

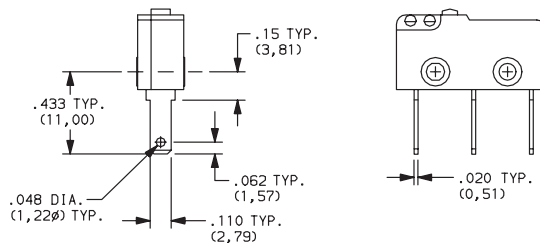

NOTE: Use Amp Quick Connect Part No. 640932-1.

J WIRE LEAD

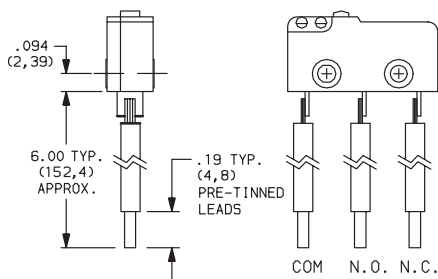

| RATING | WIRE SIZE |
|-----------|-----------|
| 1 AMP | 22 AWG |
| 5 AMPS | 20 AWG |
| 10.1 AMPS | 18 AWG |

| TERMINAL | WIRE COLOR |
|-----------------|------------|
| COMMON | BLACK |
| NORMALLY OPEN | WHITE |
| NORMALLY CLOSED | RED |

L LEFT FORMED PC THRU-HOLE

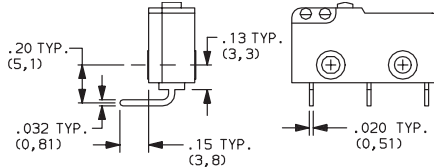

PC MOUNTING

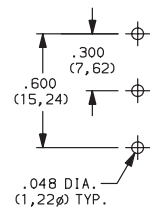

R RIGHT FORMED PC THRU-HOLE

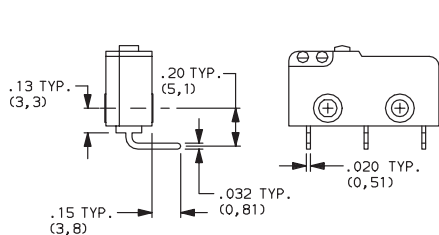

PC MOUNTING

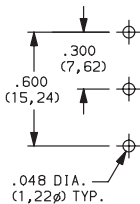

S PC THRU-HOLE

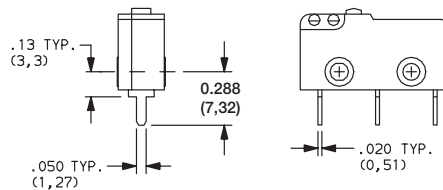

PC MOUNTING

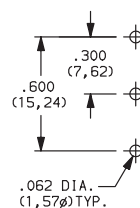

CIRCUITRY

C SPDT (Single Pole, Double Throw)

W SPST N.C. (Single Pole, Single Throw, Normally Closed)

Y SPST N.O. (Single Pole, Single Throw, Normally Open)

ELECTRICAL LIFE

NONE 6,000 OPERATIONS

U EXTENDED 100,000 OPERATIONS

SEAL

NONE NO SEAL

E EPOXY SEAL

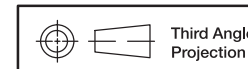
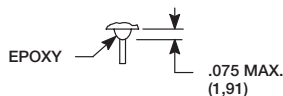

Third Angle Projection

Dimensions are shown: mm
Specifications and dimensions subject to change

C&K

LCA Series Subminiature Snap-acting Switches



Features/Benefits

- Compact design
- Long life and high electrical capacity
- Quick connect, solder terminals, PC terminals
- Wide variety of actuator styles
- RoHS compatible

Typical Applications

- Motorized equipment
- Sump pump
- Thermostatic controls

UL61058-1



Specifications

CONTACT RATING: From low level to 10.1 AMPS @ 125/250 V AC
 ELECTRICAL LIFE: see chart below
 MECHANICAL LIFE: 300,000 cycles.
 INSULATION RESISTANCE: 100 M ohm min.
 DIELECTRIC STRENGTH: 1,500 Vrms min. @ sea level.
 OPERATING TEMPERATURE: -40°C to +125°C
 OPERATING FORCE: 150 grams at actuator button MAX.
 Forces are less at free end of lever actuators; (see ACTUATOR'S option sections).
 MOUNTING: 2-56 screws, torque 2.3 in/lbs max.

Materials

SWITCH HOUSING: Thermoplastic polyester
 ACTUATOR BUTTON: Thermoplastic polyester.
 SPRING: Copper alloy.
 PIVOT: Copper alloy.
 MOVABLE CONTACTS: Silver alloy
 STATIONARY CONTACTS: Silver alloy
 TERMINALS: Copper alloy.
 ACTUATOR LEVER: Stainless steel.

NOTE: Specifications and materials listed above are for switches with standard options.
 For information on specific and custom switches, consult Customer Service center.

Build-A-Switch

To order, simply select desired option from each category and place in the appropriate box. Available options are shown and described on pages J-36 thru J-39. For additional options not shown in catalog, consult Customer Service Center.

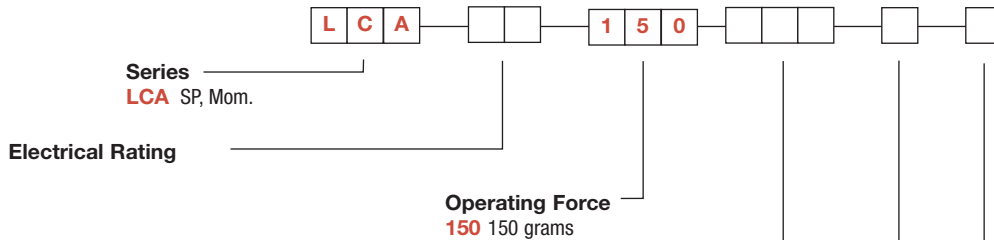

| Option Code | UL 1054 | UL 61058-1 | RoHS |
|-------------|-------------------------|-------------------------|-------------------------|
| 01 | 0.1 A 125/250 V AC 1E4 | 0.1 A 125/250 V AC 1E4 | 0.1 A 125/250 V AC 1E4 |
| 06 | 6 A 125/250 V AC 1E4 | 6 A 125/250 V AC 1E4 | 6 (2)A 125/250 V AC 1E4 |
| 10 | 10.1 A 125/250 V AC 1E4 | 10.1 A 125/250 V AC 1E4 | 10.1 A 125/250 V AC 1E4 |
| S5 | NA | 5 A 125/250 V AC 1E5 | NA |

Actuator

- P00 Pin plunger
- T05 4.8 mm short lever
- T06 6.8 mm lever
- T09 8.8 mm lever
- T12 12.9 mm lever
- T16 15.2 mm lever
- T18 18.1 mm lever
- T21 20.1 mm lever
- T23 23.4 mm lever
- T43 43.5 mm lever
- S06 6.0 mm simulated lever
- S09 9.2 mm simulated lever
- A05 5.0 mm lever roller

Terminations

- S Solder
- Q .110 Quick Connect
- P PC Thru Hole
- L Left Form PC
- R Right Form PC

Circuitry

- C SPDT
- W SPST N.C.
- Y SPST N.O.

Snap-acting

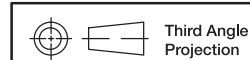

Dimensions are shown: mm
 Specifications and dimensions subject to change

LCA Series Subminiature Snap-acting Switches

SERIES 

LCA

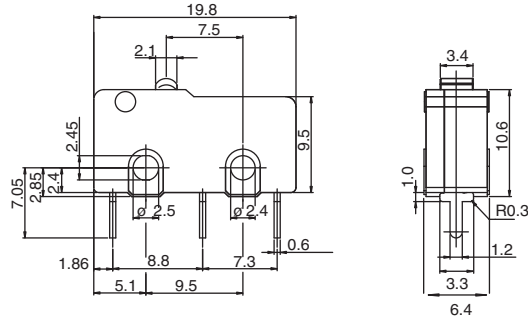

ELECTRICAL RATING 

| RoHS COMPLIANT * | RoHS COMPATIBLE * | OPTION CODE | ELECTRICAL RATING |
|------------------|-------------------|-------------|--------------------|
| YES | YES | 01 | 0.1A, 125/250 VAC |
| YES | YES | 06 | 6A, 125/250 VAC |
| YES | YES | 10 | 10.1A, 125/250 VAC |
| YES | YES | S5 | 5A, 125/250 VAC |

* Note: See Technical Data section of this catalog for RoHS compliant and compatible definition and specifications.

OPERATING FORCE 

| OPTION CODE | OPERATING FORCES (grams) |
|-------------|--------------------------|
| 150 | 150 grams max. |

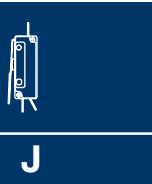

Snap-acting

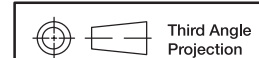

Dimensions are shown: mm
Specifications and dimensions subject to change

LCA Series Subminiature Snap-acting Switches

ACTUATOR

A05 LEVER ROLLER

SXX SIMULATED ROLLER

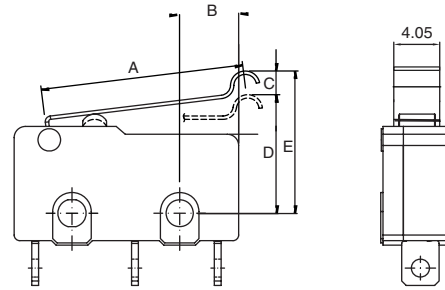
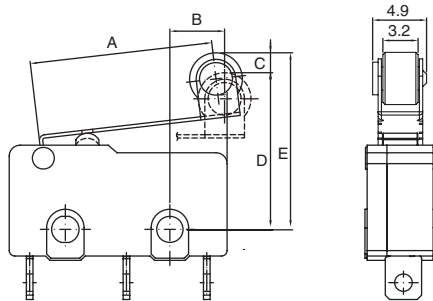

Snap-acting

TXX LEVER

P00

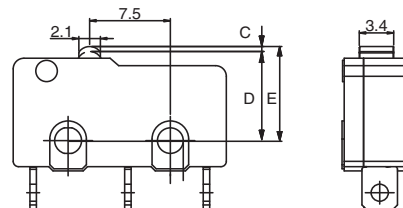
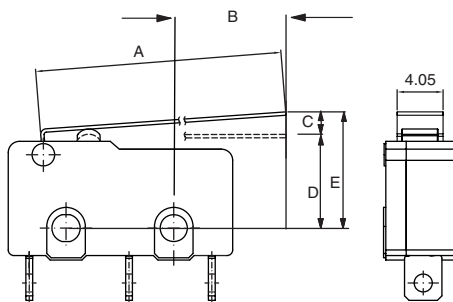

| ACTUATOR OPTION CODE | A mm | B mm | eC mm | D mm | E mm | Diff. Motion mm max | Oper. Force max. grams | Release Force min. grams | Over Travel min. |
|----------------------------|-----------------------|--|------------------------|-----------------------|---------------------------|---------------------------|---------------------------------|-----------------------------------|------------------------|
| | LENGTH OF LEVER | Lever length for front mtg. hole to OP | PRE TRAVEL (MAX) | OPERATING POSITION | FREE POSITION (MAX) | | | | |
| P00 | NA | NA | 1.10 | 8.55 ± 0.3 | 9.35 | 0.20 | 150 | 25 | 0.4 |
| T05 | 16.70 | 4.80 | 3.60 | 8.95 ± 0.8 | 11.75 | 0.80 | 50 | 6 | 0.6 |
| T06 | 18.70 | 6.80 | 4.03 | 8.9 ± 0.9 | 12.09 | 0.90 | 45 | 5 | 0.67 |
| T09 | 20.60 | 9.10 | 5.64 | 9.15 ± 1.35 | 13.45 | 1.83 | 33 | 2 | 0.75 |
| T12 | 24.80 | 12.90 | 3.35 | 8.95 ± 1.5 | 13.10 | 1.19 | 34 | 2 | 0.89 |
| T16 | 27.10 | 15.20 | 7.20 | 9.15 ± 1.7 | 15.15 | 1.30 | 40 | 1 | 0.70 |
| T18 | 30.00 | 18.10 | 7.70 | 8.95 ± 1.9 | 14.65 | 1.50 | 32 | 1 | 1.2 |
| T21 | 32.00 | 20.10 | 8.00 | 8.15 ± 1.85 | 15.55 | 1.60 | 35 | 1 | 1.0 |
| T23 | 35.20 | 23.40 | 8.60 | 8.95 ± 2.0 | 15.55 | 1.80 | 25 | 1 | 1.5 |
| T43 | 55.20 | 43.50 | 10.45 | 8.95 ± 3.0 | 19.25 | 2.90 | 15 | 1 | 1.0 |
| S06 | 17.90 | 6.00 | 3.86 | 10.85 ± 0.9 | 17.81 | 0.86 | 47 | 5 | 0.64 |
| S09 | 21.10 | 9.20 | 5.7 | 16.15 ± 1.5 | 20.35 | 1.00 | 42 | 2 | 1.0 |
| A05 | 16.60 | 5.00 | 3.8 | 14.65 ± 0.8 | 17.65 | 0.80 | 50 | 6 | 0.6 |



Third Angle
Projection

Dimensions are shown: mm
Specifications and dimensions subject to change



LCA Series Subminiature Snap-acting Switches

TERMINATIONS

S SOLDER

Q QUICK CONNECT

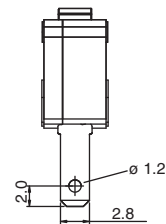
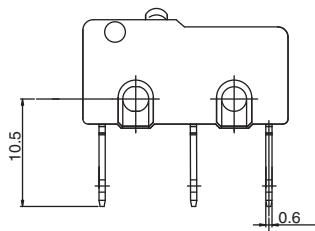
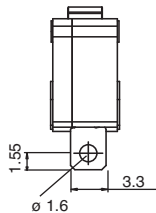
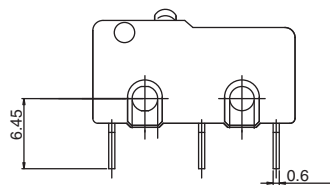

P PC THRU HOLE

L LEFT FORM PC

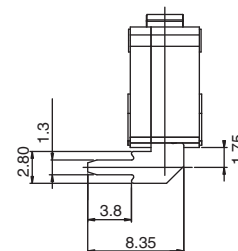
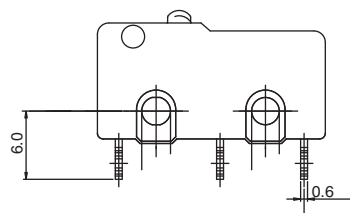
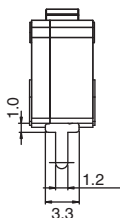
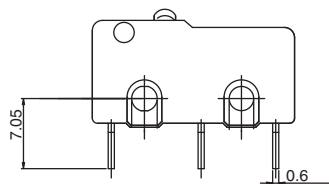

R RIGHT FORM PC

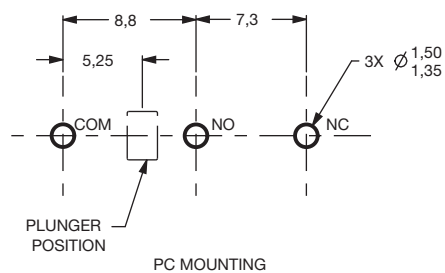
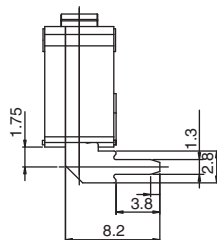
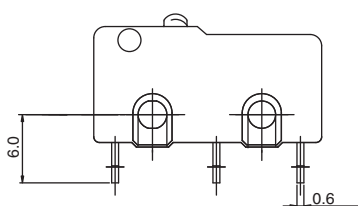

Snap-acting

CIRCUITRY

C SPDT (Single Pole, Double Throw)

W SPST N.C. (Single Pole, Single Throw, Normally Closed)

Y SPST N.O. (Single Pole, Single Throw, Normally Open)



Third Angle Projection

Dimensions are shown: mm
Specifications and dimensions subject to change



LCS Series Subminiature Sealed Snap-acting Switches



UL61058-1

Features/Benefits

- Compact design
- Long life and high electrical capacity
- Quick connect, solder terminals, PC terminals, wire leads
- Wide variety of actuator styles
- RoHS compatible, RoHS compliant
- IP67

Typical Applications

- Motorized equipment
- Sump pump
- Thermostatic controls
- Computers
- Air conditioners

Specifications

CONTACT RATING: from low level to 5 Amp
 ELECTRICAL LIFE: 10,000 cycles
 INSULATION RESISTANCE: 100 M ohm min.
 DIELECTRIC STRENGTH: 1,000 VAC
 OPERATING TEMPERATURE:
 -40°C to +120°C (without wire)
 -40°C to +85°C (with UL1007 wire)
 -40°C to +105°C (with UL1015 wire)
 -40°C to +105°C (with UL1430 wire)
 -40°C to +80°C (with UL1061 wire)
 -40°C to +120°C (with UL1330 wire)
 OPERATING FORCE: (see ACTUATOR'S option sections).
 MOUNTING: 2-56 screws, torque 2.3 in/lbs max.

Materials

SWITCH HOUSING: Thermoplastic polyester or high temperature thermoplastic (PTS) (UL 94V-0).
 ACTUATOR BUTTON: Thermoplastic polyester.
 SPRING: Copper alloy.
 PIVOT: Copper alloy.
 MOVABLE CONTACTS: Option "01" Gold plating over silver alloy
 Option "05" Silver alloy
 STATIONARY CONTACTS: Option "01" Gold plating over silver alloy
 Option "05" Silver alloy
 TERMINALS: Copper alloy.
 ACTUATOR LEVEL: Stainless steel.

NOTE: Specifications and materials listed above are for switches with standard options.
 For information on specific and custom switches, consult Customer Service center.

Snap-acting

Build-A-Switch

To order, simply select desired option from each category and place in the appropriate box. Available options are shown and described on pages J-40 thru J-43. For additional options not shown in catalog, consult Customer Service Center.

| | | | | | | |
|----------------------|--------------------|--------------|---------------------------------------|----------------------------------|--|--|
| Series LCS | | | Operating Force 2 203 grams | | Circuitry C SPDT W SPST N.C. Y SPST N.O. | |
| Electrical Rating | | | Actuator | | Wire Type AWG | |
| Option Code | UL 61058-1 | | P00 Pin plunger | Wire UL # (when required) | | |
| 01 | 0.1 A 125/250 V AC | NA | T00 11.9 mm short lever | 20 20 AWG | A UL1007 | |
| 05 | 5 A 125/250 V AC | 6 A 250 V AC | T05 17.4 mm short lever | 22 22 AWG | B UL1015 | |
| | | | T07 19.4 mm short lever | 24 24 AWG | C UL1430 | |
| | | | T13 25.5 mm lever | 26 26 AWG | D UL1061 | |
| | | | T19 33.3 mm lever | Wire Side (when required) | | |
| | | | T28 40.7 mm lever | A Wire out the bottom | | |
| | | | T43 55.9 mm lever | B Wire out the right side | | |
| | | | S26 18.6 mm simulated lever | C Wire out the left side | | |
| | | | A05 17.2 mm lever roller | D None | | |
| | | | Terminations | | | |
| | | | S Solder | | | |
| | | | Q 0.110 Quick Connect | | | |
| | | | P PC Thru Hole | | | |
| | | | W Wire leads potted | | | |
| | | | Z Wire leads non-potted | | | |



Dimensions are shown: mm
 Specifications and dimensions subject to change

LCS Series Subminiature Sealed Snap-acting Switches

SERIES

LCS

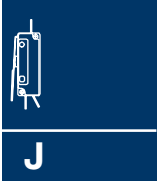
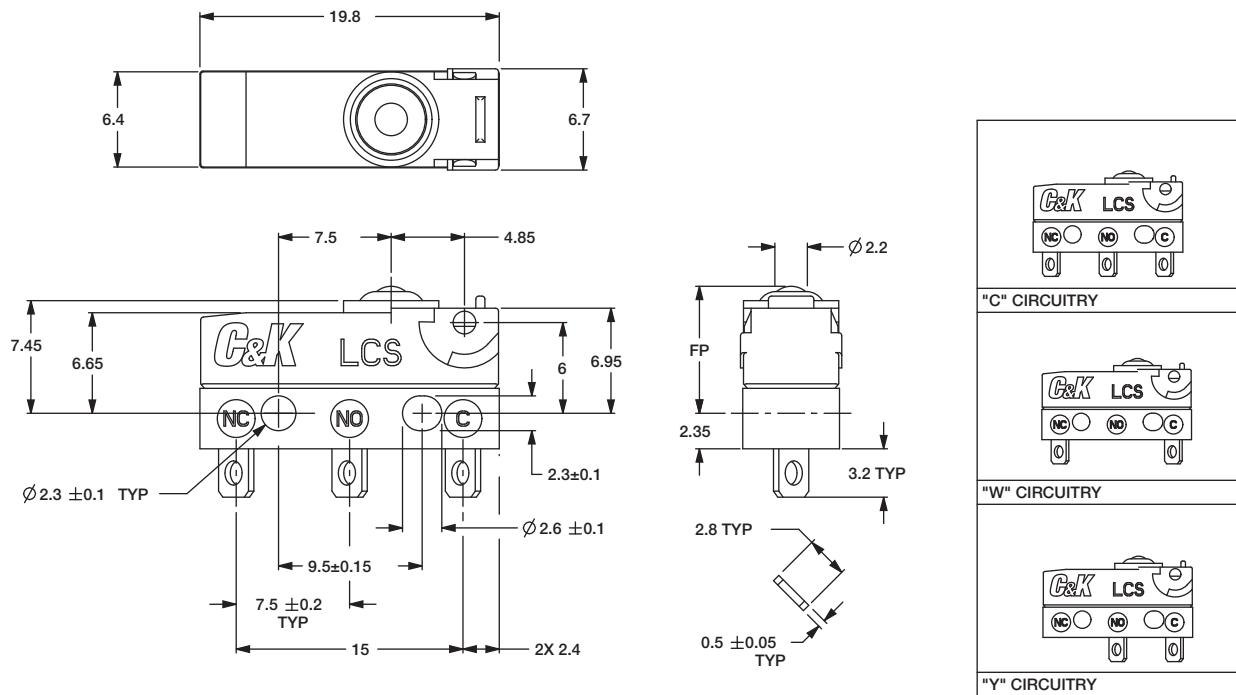

Snap-acting

ELECTRICAL RATING

| RoHS COMPLIANT * | RoHS COMPATIBLE * | OPTION CODE | ELECTRICAL RATING |
|------------------|-------------------|-------------|-----------------------|
| YES | YES | 05 | 5 AMP, 125/250 V AC |
| YES | YES | 01 | 0.1 AMP, 125/250 V AC |

OPERATING FORCE

| OPTION CODE | OPERATING FORCES (grams) |
|-------------|--------------------------|
| 2 | 203 g. max. |

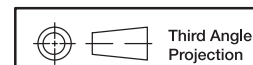

Third Angle Projection
Dimensions are shown: mm
Specifications and dimensions subject to change

LCS Series Subminiature Sealed Snap-acting Switches

ACTUATOR

P00

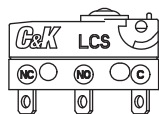

T19

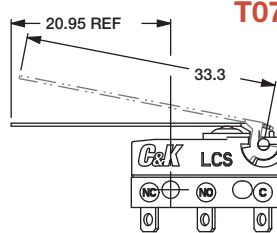

T07

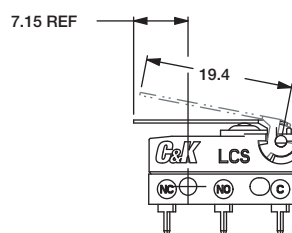

A05

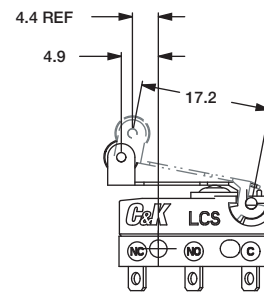

T00

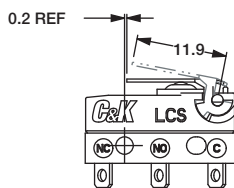

T28

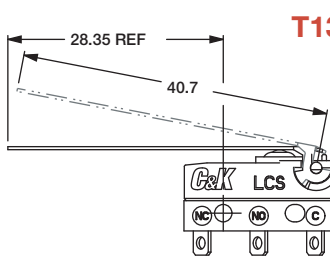

T13

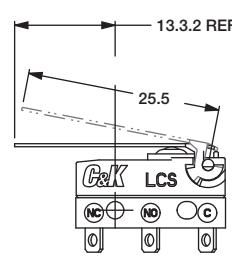

S26

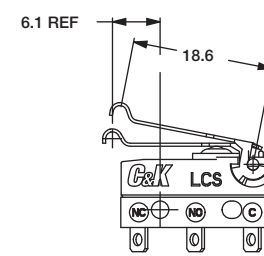

T05

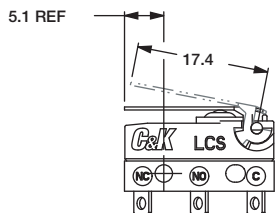

T43

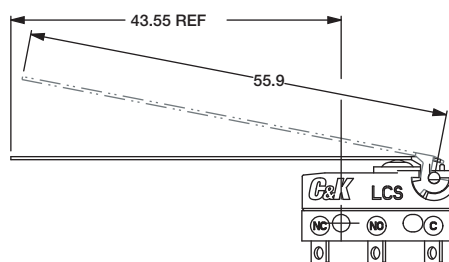

Snap-acting

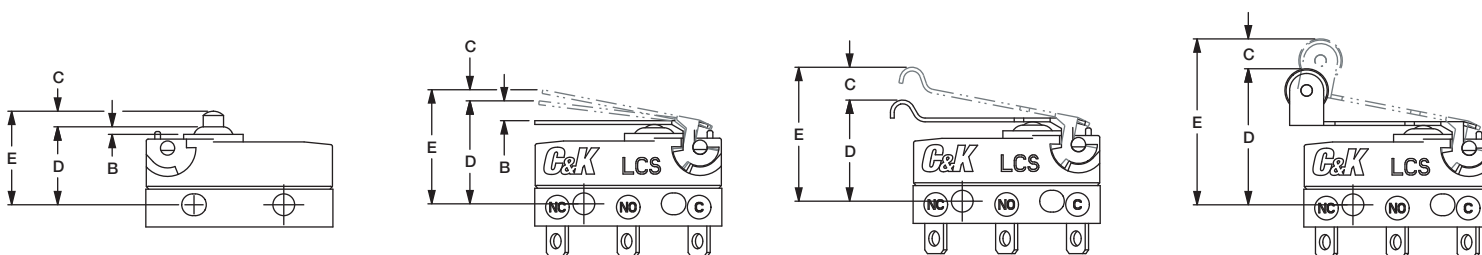

| ACTUATOR OPTION CODE | A | B | C | D | E | DIFFERENTIAL MOTION (MAX) | OPERATING FORCE (MAX) | RELEASE FORCE (MIN) |
|----------------------------|-----------------------|-------------------------|------------------------|-----------------------|---------------------------|------------------------------|--------------------------|------------------------|
| | LENGTH OF LEVER | OVER TRAVEL (MIN) | PRE TRAVEL (MAX) | OPERATING POSITION | FREE POSITION (MAX) | 203 | 203 | 203 |
| P00 | N/A | 0.6 | 1.2 | 8.4 ± 0.3 | 9.9 | 0.2 | 203 | 50 |
| T00 | 11.9 | 0.6 | 3.2 | 8.8 ± 0.9 | 11.1 | 0.5 | 98 | 21 |
| T05 | 17.40 | 0.9 | 4.3 | 8.8 ± 1.1 | 12 | 0.6 | 82 | 16 |
| T07 | 19.40 | 1 | 4.8 | 8.8 ± 1.2 | 12.4 | 0.7 | 66 | 13 |
| T13 | 25.5 | 1.6 | 6.3 | 8.8 ± 1.6 | 13.5 | 0.9 | 54 | 11 |
| T19 | 33.3 | 1.95 | 8 | 8.8 ± 2.0 | 15 | 1.75 | 40 | 5 |
| T28 | 40.7 | 2.1 | 10.1 | 8.8 ± 2.6 | 16.3 | 2.3 | 39 | 8 |
| T43 | 55.9 | 2.9 | 13.8 | 8.8 ± 3.5 | 19.1 | 3.6 | 33 | 7 |
| S26 | 18.6 | 1 | 4.6 | 10.7 ± 1.2 | 14.1 | 0.65 | 68 | 14 |
| A05 | 17.20 | 0.9 | 4.3 | 14.5 ± 1.1 | 17.7 | 0.6 | 72 | 15 |

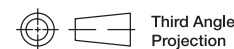

Third Angle
Projection
Dimensions are shown: mm
Specifications and dimensions subject to change



LCS Series Subminiature Sealed Snap-acting Switches

TERMINATIONS

S SOLDER

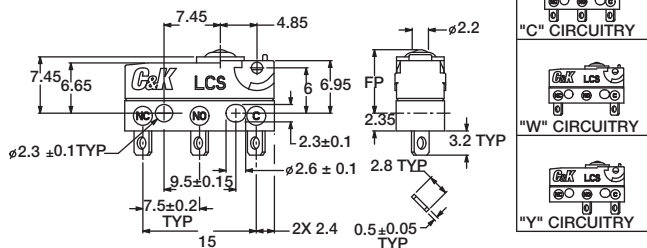

Q QUICK CONNECT 2.8mm / 0.110"

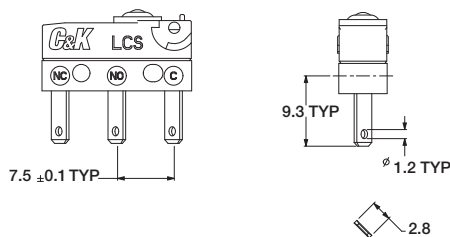

P PC THRU HOLE

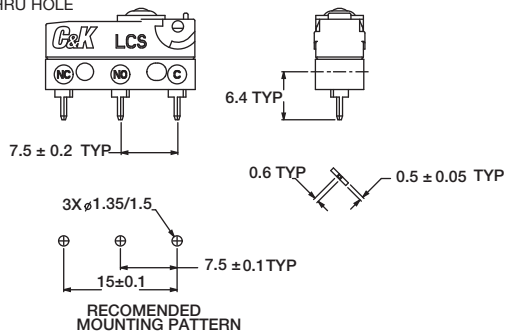

Z or W "A" WIRE ORIENTATION

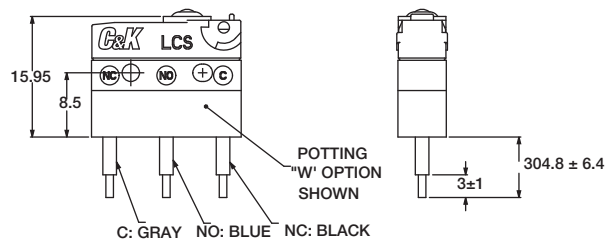

Z or W "B" WIRE ORIENTATION "Y" OR "W" CIRCUITRY

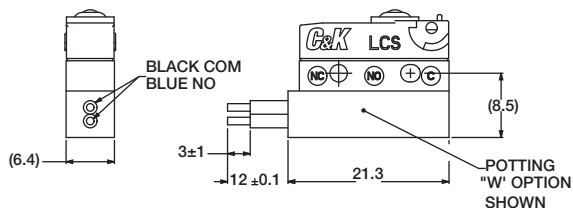

Z or W "C" WIRE ORIENTATION "Y" OR "W" CIRCUITRY

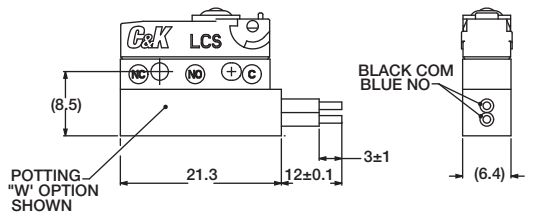

Z or W "B" WIRE ORIENTATION "C" CIRCUITRY

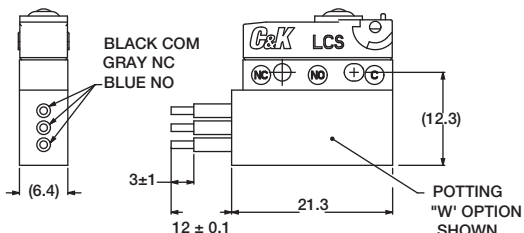

Z or W "C" WIRE ORIENTATION "C" CIRCUITRY

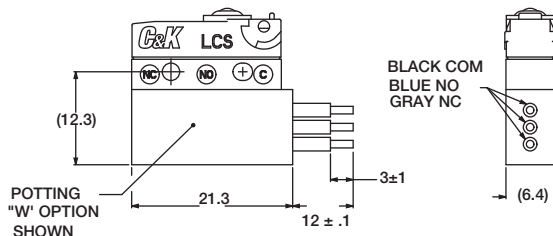

CIRCUITRY

- C** SPDT (Single Pole, Double Throw)
- W** SPST N.C. (Single Pole, Single Throw, Normally Closed)
- Y** SPST N.O. (Single Pole, Single Throw, Normally Open)



Third Angle
Projection

Dimensions are shown: mm
Specifications and dimensions subject to change

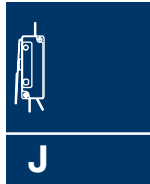

Snap-acting

MM Series Subminiature Precision Snap-acting Switches



Features/Benefits

- Low level and power switching
- Long electrical and mechanical life
- Increased overtravel
- Reliable snap-acting mechanism

Typical Applications

- Limited space constraints
- Communication devices

Specifications

CONTACT RATING: From low level* to 7 AMPS @ 250 V AC.
 ELECTRICAL LIFE: 100,000 cycles at full rated load.
 INSULATION RESISTANCE: 1,000 ohm min.
 DIELECTRIC STRENGTH: 1,000 V RMS min. @ sea level.
 OPERATING TEMPERATURE: -67 F to 275 F (-55 C to 135 C).
 OPERATING FORCE: 5 oz. (142 grams) max. at actuator button.
 MOUNTING: 2-56 screws, torque 2 in/lbs max.

*Low Level=conditions where no arcing occurs during switching, i.e., 0.4 VA max. @ 20 V AC or DC max.

NOTE: Specifications and materials listed above are for switches with standard options. For information on specific and custom switches, consult Customer Service center.

Materials

SWITCH HOUSING: Heat resistant phenolic (UL 94V-0).
 ACTUATOR BUTTON: Heat resistant phenolic (UL 94V-0).
 SPRING: Beryllium copper CDA alloy C17200.
 PIVOT: Brass CDA alloy 260.
 MOVABLE CONTACTS: Fine silver for ratings greater than 1 AMP @ 125 V AC. 24K gold for 1 AMP @ 125 V AC or less.
 STATIONARY CONTACTS: Fine silver inlay on copper CDA alloy C10200 for ratings greater than 1 AMP @ 125 V AC. 24K gold on copper CDA alloy C10200 for 1 AMP @ 125 V AC or less.
 TERMINALS: Copper CDA alloy C18700.



Build-A-Switch

To order, simply select desired option from each category and place in the appropriate box. Available options are shown and described on pages J-44 through J-49. For additional options not shown in catalog, consult Customer Service Center.

Snap-acting

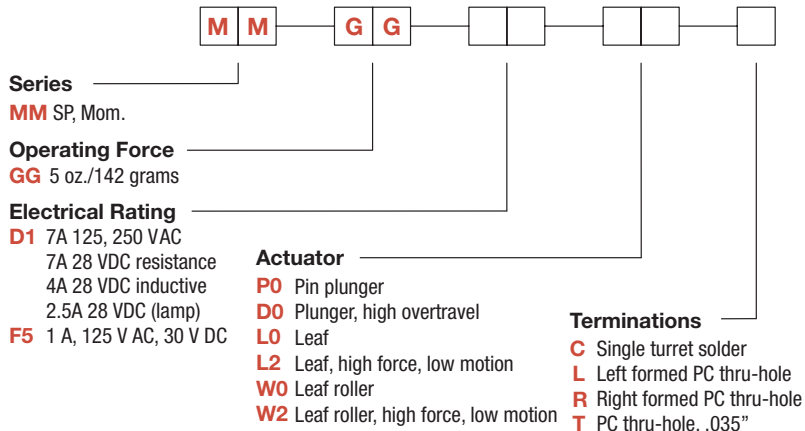

Dimensions are shown: Inch (mm)
 Specifications and dimensions subject to change

MM Series Subminiature Precision Snap-acting Switches

SWITCH WITH STANDARD OPTIONS



MMGGD1P0C

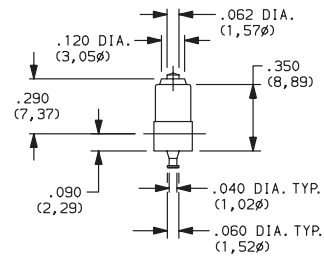
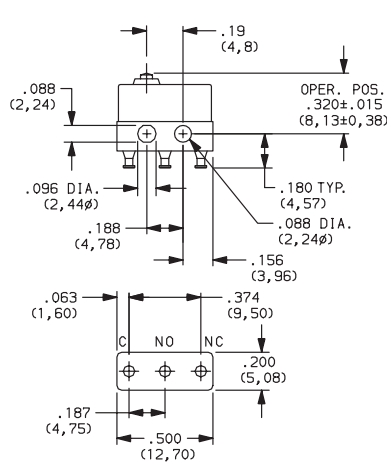

| PART NUMBER | BASIC OPERATING FORCE (OZ./GRAMS) | ELECTRICAL RATING |
|------------------|-----------------------------------|--------------------|
| MMGGD1P0C | 5 142 | 7 AMPS @ 250 V AC. |

SERIES ■ ■ ■ ■ ■ ■ ■ ■

MM SPDT MOMENTARY

OPERATING FORCE ■ ■ ■ ■ ■ ■ ■ ■

| OPTION CODE | BASIC SWITCH OPERATING FORCE |
|-------------|--|
| GG | 5 oz. (142 grams) maximum for basic switch with pin plunger actuator ('PO' actuator option). |

NOTE: Operating force varies with actuator option, see ACTUATOR option section.

ELECTRICAL RATING ■ ■ ■ ■ ■ ■ ■ ■

| OPTION CODE | RoHS COMPLIANT* | RoHS COMPATIBLE* | CONTACT MATERIAL | | ELECTRICAL RATING |
|-------------|-----------------|------------------|------------------|------------------------------------|--|
| | | | MOVABLE CONTACT | STATIONARY CONTACT | |
| D1 | Yes | Yes | Fine silver. | Fine silver inlay on copper alloy. | 7A 125, 250 VAC; 7A 28 VDC resistance 4A 28 VDC inductive; 2.5A 28 VDC (lamp) |
| F5 | Yes | Yes | 24K Gold. | 24K Gold on copper alloy. | From low level* to 1 AMP @ 125 V AC, 30 V DC. |

Note: See Technical Data section of this catalog for RoHS compliant and compatible definition and specifications.

All models with all options.

Consult Customer Service Center for availability and delivery of nonstandard ratings.

* Low Level=conditions where no arcing occurs during switching, i.e., 0.4 VA max. @ 20 V AC or DC max.

ACTUATOR ■ ■ ■ ■ ■ ■ ■ ■

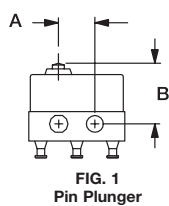

FIG. 1
Pin Plunger

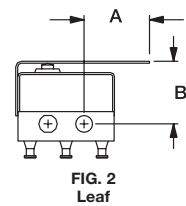

FIG. 2
Leaf

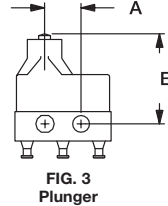

FIG. 3
Plunger

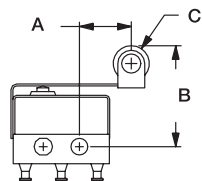

FIG. 4
Leaf Roller

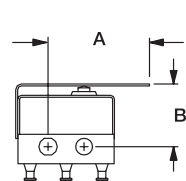

FIG. 5
Leaf

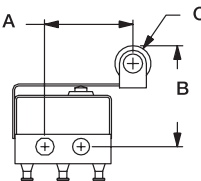

FIG. 6
Leaf Roller

| OPTION CODE | FIG. | DIM. A | DIM. B | DIM. C |
|-------------|------|---------------|-------------------------------|----------------------|
| P0 | 1 | .19 (4,8) | .320 ± .015 (8,13 ± 0,38) | — |
| D0 | 3 | .19 (4,8) | .475 ± .031 (12,07 ± 0,79) | — |
| L0 | 2 | .34 (8,6) | .330 ± .015 (8,38 ± 0,38) | — |
| L2 | 5 | .53 (13,5) | .330 ± .015 (8,38 ± 0,38) | — |
| W0 | 4 | .27 (6,9) | .532 ± .025 (13,51 ± 0,64) | .188 dia. (4,780) |
| W2 | 6 | .46 (11,7) | .532 ± .025 (13,51 ± 0,64) | .188 dia. (4,780) |



Third Angle Projection

Dimensions are shown: Inches (mm)
Specifications and dimensions subject to change

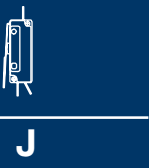

Snap-acting

MM Series Subminiature Precision Snap-acting Switches

ACTUATOR

SWITCH CHARACTERISTICS

| OPTION CODE | MAXIMUM OPERATING FORCE (OZ./GRAMS) | MINIMUM RELEASE FORCE (OZ./GRAMS) | MAXIMUM DIFFERENTIAL TRAVEL | MAXIMUM PRETRAVEL | MINIMUM OVERTRAVEL |
|-------------|-------------------------------------|-----------------------------------|-----------------------------|-------------------|--------------------|
| D0 | 5 142 | .7 20 | .004 (0,10) | .030 (0,76) | .040 (1,02) |
| L0 | 4 115 | .7 20 | .025 (0,64) | .090 (2,29) | .045 (1,14) |
| L2 | 6 170 | .7 20 | .012 (0,30) | .075 (1,90) | .015 (0,38) |
| P0 | 5 142 | 1 28 | .002 (0,05) | .020 (0,51) | .004 (0,10) |
| W0 | 4 115 | .7 20 | .025 (0,64) | .090 (2,29) | .045 (1,14) |
| W2 | 6 170 | .7 20 | .012 (0,30) | .075 (1,90) | .015 (0,38) |

NOTE: For basic switch operating forces, see page J-44

TERMINATIONS

C SINGLE TURRET SOLDER

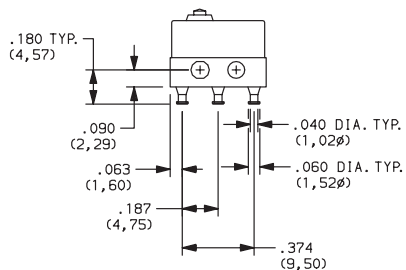

L LEFT FORMED PC THRU-HOLE

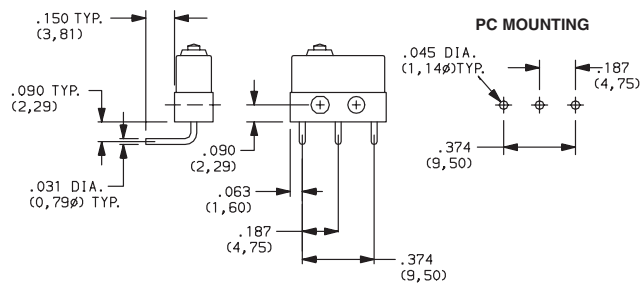

T PC THRU-HOLE, .035"

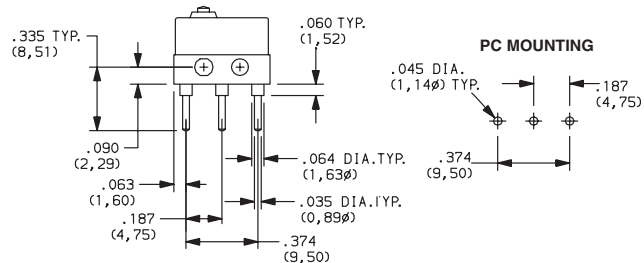

R RIGHT FORMED PC THRU-HOLE

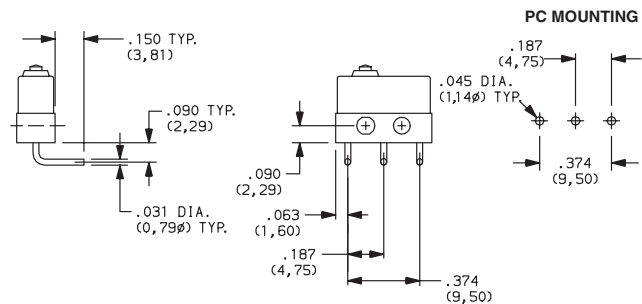

Snap-acting



Dimensions are shown: Inch (mm)
Specifications and dimensions subject to change

ZM Series Subminiature Snap-acting Switches

Features/Benefits

- **Reliable snap-acting mechanism**
- **Long electrical and mechanical life**
- **Compact size—Ideal when space is limited**
- **Various PCB terminals and actuators**
- **RoHS compliant / compatible**

Typical Applications

- **PCB detection switch**
- **Communication devices**
- **Testing equipment**
- **Security/Alarm systems**
- **Consumer electronics**

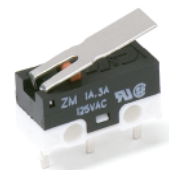

UL61058-1



Specifications

CONTACT RATING: F7: 3A @ 125 VAC
M9: 0.2A @ 60 VDC.

ELECTRICAL LIFE: 10,000 Cycles. @ 3A

INSULATION RESISTANCE: 100 M ohm min.

DIELECTRIC STRENGTH: 1000 Vrms.

OPERATING TEMPERATURE: -30°C to 85°C.

OPERATING FORCE: CJ: 150 grams, CH: 90 grams.

* Low Level=conditions where no arcing occurs during switching, i.e., 0.4 VA max. @ 20 V AC or DC max.

Materials

COVER: Nylon 6/6

ACTUATOR BUTTON: Nylon 6/6

CASE: Nylon 6/6

SPRING: SUS

MOVABLE BLADE: BeCu

MOVABLE CONTACT: Silver alloy (M9 option gold plated)

FIXED CONTACTS: Silver alloy (M9 option gold plated)

FIXED TERMINALS: Brass - Ag plated.

ACTUATOR (Leaf / Roller options): SUS

NOTE: Specifications and materials listed above are for switches with standard options. For information on specific and custom switches, consult Customer Service Center.

Build-A-Switch

To order, simply select desired option from each category and place in the appropriate box. Available options are shown and described on pages J-48 and J-49. For additional options not shown in catalog, consult Customer Service Center.

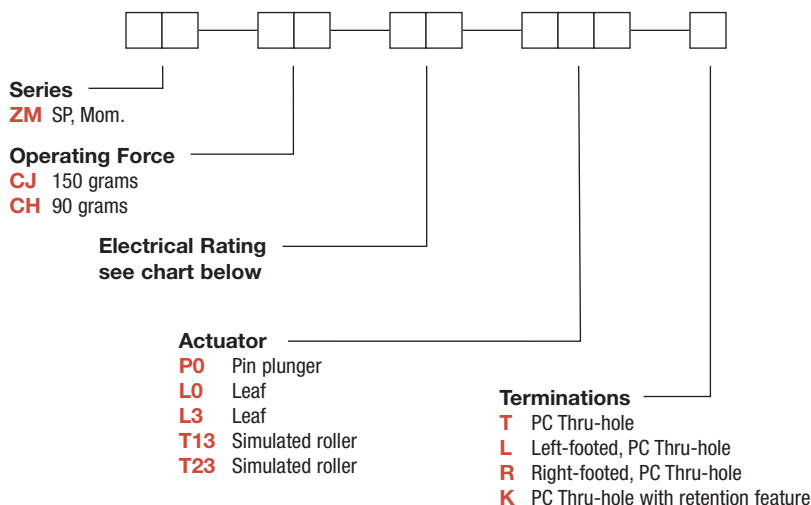

| Option Code | UL cUL US 1054 | UL cUL US 61058-1 | RoHS |
|-------------|--|--|--|
| F7 | 3 A 125 V AC | 3 A 125 V AC 3 A 30 V DC | 3 A 125 V AC |
| M9 | 0.1 A 48 V DC 0.2 A 60 V DC 0.1 A 125 V AC | 0.1 A 48 V DC 0.2 A 60 V DC 0.1 A 125 V AC | 0.1 A 48 V DC 0.2 A 60 V DC 0.1 A 125 V AC |



Dimensions are shown: Inches (mm)
Specifications and dimensions subject to change



Snap-acting

ZM Series Subminiature Snap-acting Switches

SERIES **ZM** ■ ■ ■ ■ ■ ■ ■ ■

ZM SUBMINIATURE SNAP-ACTING SWITCHES – SP MOMENTARY

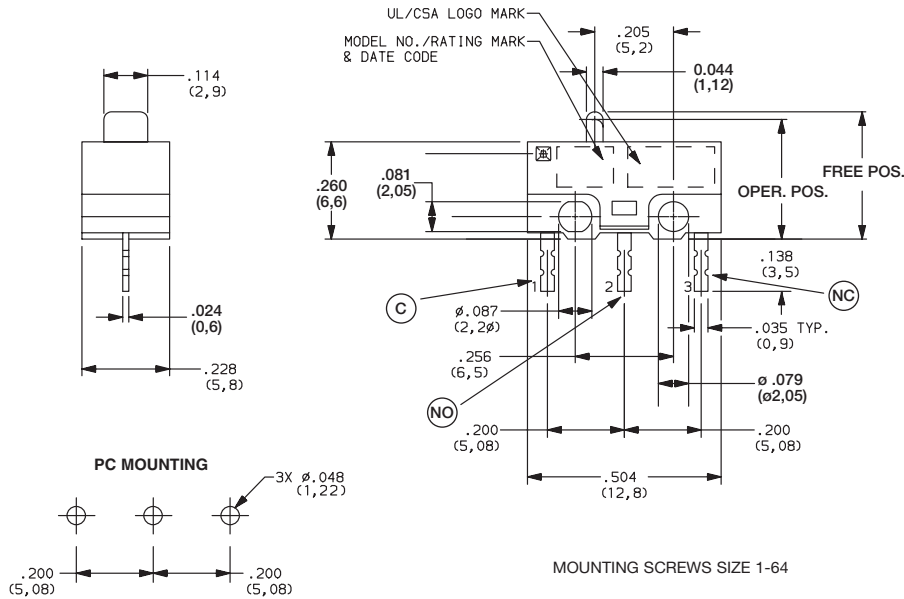

ZMCJF7L0T
SPDT

OPERATING FORCE ■ ■ ■ ■ ■ ■ ■ ■

| OPTION CODE | BASIC SWITCH OPERATING FORCE (OZ./GRAMS) |
|-------------|--|
| CJ | 5.29 150 |
| CH | 3.15 90 |

ELECTRICAL RATING ■ ■ ■ ■ ■ ■ ■ ■

| OPTION CODE | RoHS COMPLIANT* | RoHS COMPATIBLE* | CONTACT MATERIAL | | ELECTRICAL RATING |
|-------------|-----------------|------------------|------------------------------|--------------------|-------------------|
| | | | MOVABLE CONTACT | STATIONARY CONTACT | |
| F7 | Yes | Yes | Silver alloy | | see chart |
| M9 | Yes | Yes | Gold plating or silver alloy | | see chart |

* Note: See Technical Data section of this catalog for RoHS compliant and compatible definition and specifications.

All models **cULus** with all options.

Consult Customer Service center for availability and delivery of nonstandard ratings.

| Option Code | cULus 1054 | cULus 61058-1 | |
|-------------|--|--|--|
| F7 | 3 A 125 V AC | 3 A 125 V AC 3 A 30 V DC | 3 A 125 V AC |
| M9 | 0.1 A 48 V DC 0.2 A 60 V DC 0.1 A 125 V AC | 0.1 A 48 V DC 0.2 A 60 V DC 0.1 A 125 V AC | 0.1 A 48 V DC 0.2 A 60 V DC 0.1 A 125 V AC |

Snap-acting

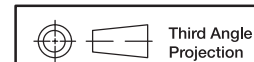

Dimensions are shown: Inch (mm)
Specifications and dimensions subject to change

ZM Series Subminiature Snap-acting Switches

ACTUATOR

P0 PIN PLUNGER

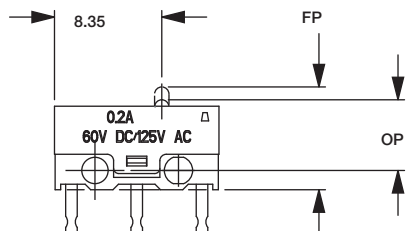

L0 LEAF, 50 GRAMS (CJ ONLY)
L3 LEAF, 30 GRAMS (CH ONLY)

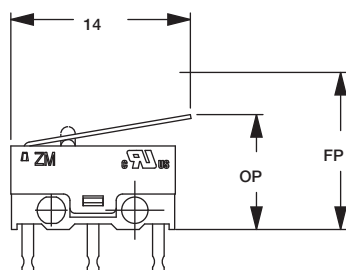

T13 SIMULATED ROLLER, 40 GRAMS (CJ ONLY)
T23 SIMULATED ROLLER, 25 GRAMS (CH ONLY)

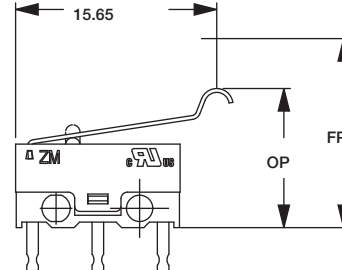

| ACTUATOR OPTION CODE | A (mm) | B Ref (mm) | C (mm) | D (mm) | E (mm) | DIFF. MOTION mm MAX | OPER. FORCE grams MAX | | RELEASED FORCE Grams MAX | OVER TRAVEL MIN |
|-------------------------|-----------------------|---------------------------------------|-----------------------|-----------------------|-------------------------|------------------------------|--------------------------------|----|-----------------------------------|-----------------------|
| | LENGTH OF LEVER | LEVER LENGTH MTG. HOLE TO OP | PRE- TRAVEL MAX | OPERATING POSITION | FREE POSITION MAX | | CJ | CH | | |
| P0 PIN PLUNGER | NA | NA | 1.3 | 7.0 ±0.3 | 8.0 | 0.3 | 150 | 90 | 15-20 | 0.2 |
| L0 LEAF | 13.0 | 4.03 | 3.4 | 8.4 ±0.8 | 11.0 | 1.3 | 50 | - | 8 | 0.6 |
| L3 LEAF | 13.0 | 4.03 | 3.4 | 8.4 ±0.8 | 11.0 | 1.3 | - | 30 | 5 | 0.6 |
| T13 SIMULATED ROLLER | 15.0 | 5.36 | 3.8 | 10.5 ±0.8 | 13.0 | 1.5 | 40 | - | 7 | 0.6 |
| T23 SIMULATED ROLLER | 15.0 | 5.36 | 3.8 | 10.5 ±0.8 | 13.0 | 1.5 | - | 25 | 4 | 0.6 |



Snap-acting

TERMINATIONS

T (STD.) PC THRU-HOLE

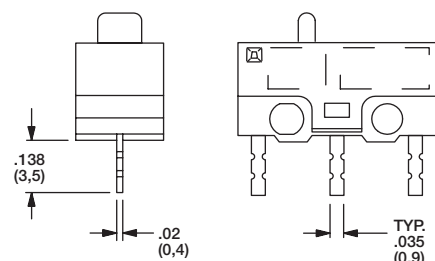

K PC THRU-HOLE WITH RETENTION FEATURE

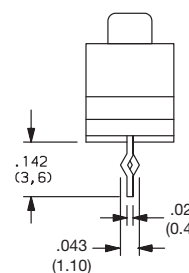

L LEFT FOOTED, PC THRU-HOLE

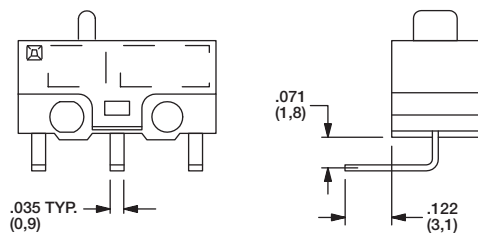

R RIGHT FOOTED, PC THRU-HOLE

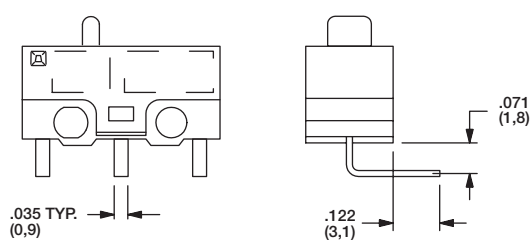

Third Angle
Projection

Dimensions are shown: Inches (mm)
Specifications and dimensions subject to change

C&K

ZMA Series Subminiature Snap-acting Switches



Features/Benefits

- **Reliable snap-acting mechanism**
- **Long electrical and mechanical life**
- **Compact size—Ideal when space is limited**
- **Various PCB terminals and actuators**
- **RoHS compatible & compliant**

Typical Applications

- **PCB detection switch**
- **Communication devices**
- **Testing equipment**
- **Security/Alarm systems**
- **Consumer electronics**

UL61058-1



Specifications

CONTACT RATING: 3A @ 125 V AC 24 V DC
 1 A @125 / 250 V AC 24 V DC
 0.1A @ 125 V AC 60 V DC

ELECTRICAL LIFE: 300,000 cycles @ 0.1A / 10,000 cycles @ 3A.
 MECHANICAL LIFE: 1,000,000 cycles.
 INSULATION RESISTANCE: 100 M ohm min.
 DIELECTRIC STRENGTH: 500 Vrms.
 OPERATING TEMPERATURE: -40°C to 85°C
 OPERATING FORCE: 80 or 150 grams.

Materials

CASE/COVER: PBT
 ACTUATOR: Button nylon 6/6
 MOVABLE CONTACTS: Silver alloy or gold plated
 STATIONARY CONTACTS: Silver alloy or gold plated
 TERMINALS: Brass, silver plated.

NOTE: Specifications and materials listed above are for switches with standard options. For information on specific and custom switches, consult Customer Service Center.

* Low Level=conditions where no arcing occurs during switching, i.e., 0.4 VA max.
 @ 20 V AC or DC max.



Snap-acting

Build-A-Switch

To order, simply select desired option from each category and place in the appropriate box. Available options are shown and described on pages J-51 and J-53. For additional options not shown in catalog, consult Customer Service Center.

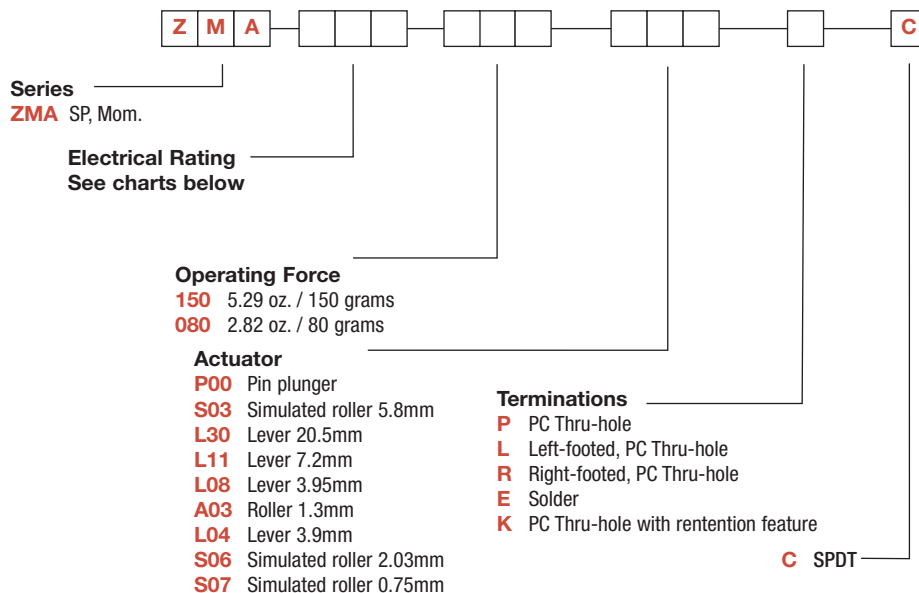

Silver Contacts

| Option Code | UL 1054 | UL 61058-1 | 14 | 15 |
|-------------|-------------------------------|-----------------------------------|---------------|-----------------------------------|
| 00A | 0.1A 60 V DC 0.1A 125 V AC | 0.1A 60 V DC 0.1A 125 V AC | 0.1A 125 V AC | |
| 03A | 3 A 125 V AC | 3 A 125 V AC 3 A 24 V DC | 3A 125 V AC | |
| 01A | | 1 A 24 V DC 1 A 125 / 250 V AC | | 1 A 24 V DC 1 A 125 / 250 V AC |

Gold Plated Contacts

| Option Code | UL 1054 | UL 61058-1 | 14 | 15 |
|-------------|-------------------------------|-----------------------------------|---------------|-----------------------------------|
| G00 | 0.1A 60 V DC 0.1A 125 V AC | 0.1A 60 V DC 0.1A 125 V AC | 0.1A 125 V AC | |
| G03 | 3 A 125 V AC | 3 A 125 V AC 3 A 24 V DC | 3A 125 V AC | |
| G01 | | 1 A 24 V DC 1 A 125 / 250 V AC | | 1 A 24 V DC 1 A 125 / 250 V AC |



Dimensions are shown: Inch (mm)
 Specifications and dimensions subject to change

ZMA Series Subminiature Snap-acting Switches

SERIES **Z M** ■ ■ ■ ■ ■ ■ ■ ■

ZMA SUBMINIATURE SNAP-ACTING SWITCHES – SP MOMENTARY

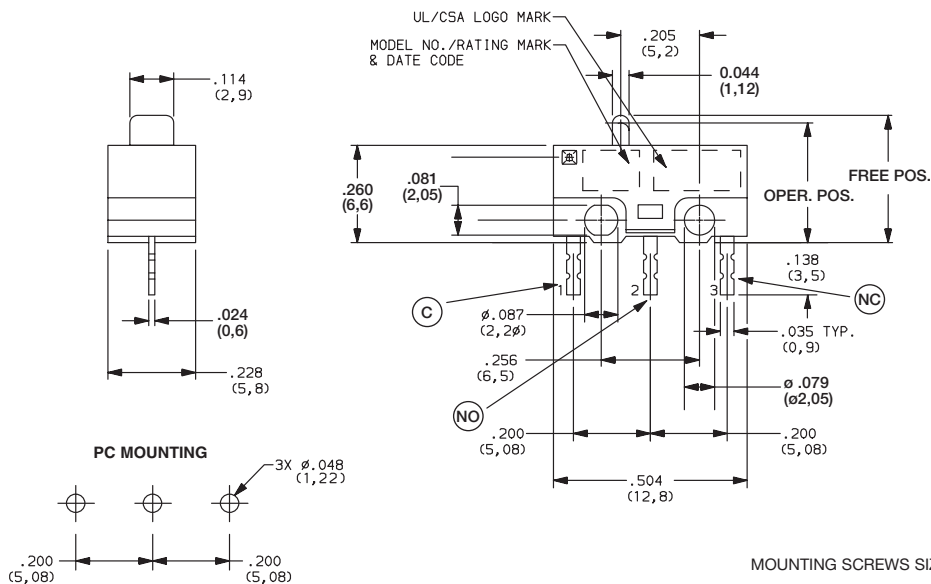

ZMA03A150L04PC
SPDT

MOUNTING SCREWS SIZE 1-64

ELECTRICAL RATING ■ ■ ■ ■ ■ ■ ■ ■



Snap-acting

Silver Contacts

Gold Plated Contacts

| Option Code | UL cUL ^{us} 1054 | UL cUL ^{us} 61058-1 | UL ¹⁴ | UL ¹⁵ | Option Code | UL cUL ^{us} 1054 | UL cUL ^{us} 61058-1 | UL ¹⁴ | UL ¹⁵ |
|-------------|-------------------------------|-----------------------------------|------------------|-----------------------------------|-------------|-------------------------------|-----------------------------------|------------------|-----------------------------------|
| 00A | 0.1A 60 V DC 0.1A 125 V AC | 0.1A 60 V DC 0.1A 125 V AC | 0.1A 125 V AC | | G00 | 0.1A 60 V DC 0.1A 125 V AC | 0.1A 60 V DC 0.1A 125 V AC | 0.1A 125 V AC | |
| 03A | 3 A 125 V AC | 3 A 125 V AC 3 A 24 V DC | 3A 125 V AC | | G03 | 3 A 125 V AC | 3 A 125 V AC 3 A 24 V DC | 3A 125 V AC | |
| 01A | | 1 A 24 V DC 1 A 125 / 250 V AC | | 1 A 24 V DC 1 A 125 / 250 V AC | G01 | | 1 A 24 V DC 1 A 125 / 250 V AC | | 1 A 24 V DC 1 A 125 / 250 V AC |

* Note: See Technical Data in section N of this catalog for RoHS compliant and compatible definition and specifications.

All models **cUL^{us}** with all options.

Consult Customer Service center for availability and delivery of nonstandard ratings.

OPERATING FORCE ■ ■ ■ ■ ■ ■ ■ ■

| OPTION CODE | BASIC SWITCH OPERATING FORCE (OZ./GRAMS) |
|-------------|--|
| 150 | 5.29 150 |
| 080 | 2.82 80 |

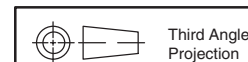

Third Angle
Projection

Dimensions are shown: Inches (mm)
Specifications and dimensions subject to change



ZMA Series Subminiature Snap-acting Switches

ACTUATOR

P00 PIN PLUNGER

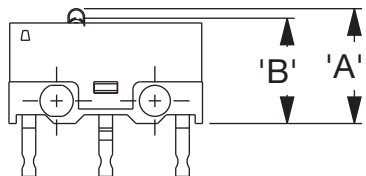

L08 LEVER
3.95MM

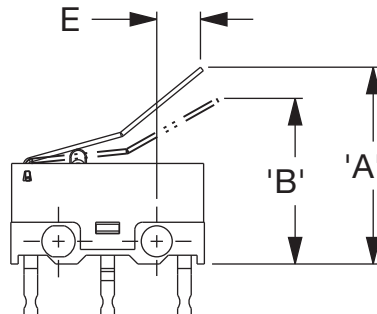

S03 SIMULATED ROLLER
5.8MM

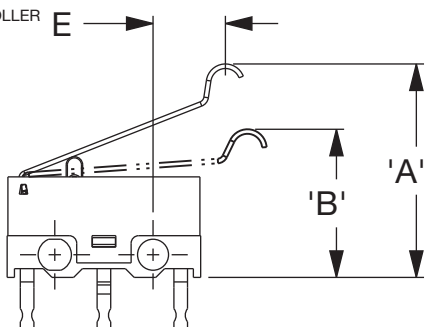

A03 ROLLER
1.3MM

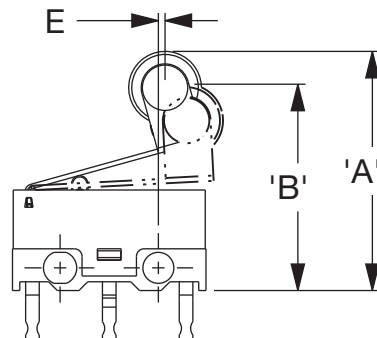

L30 LEVER
20.5MM

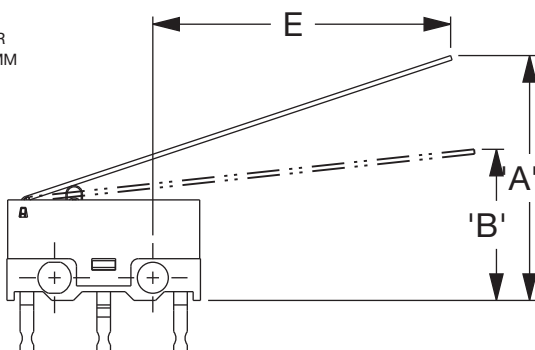

L04 LEVER
3.49MM

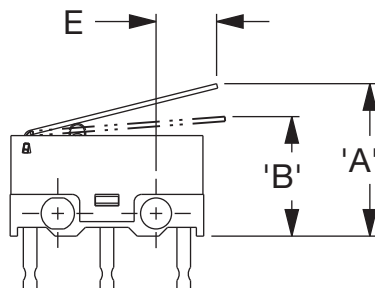

L11 LEVER
7.2MM

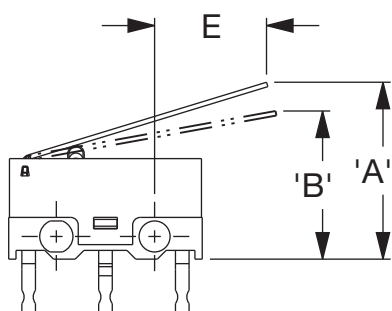

S06 SIMULATED ROLLER
2.03MM

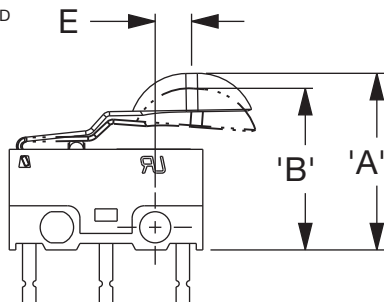

S07 SIMULATED ROLLER
0.75MM

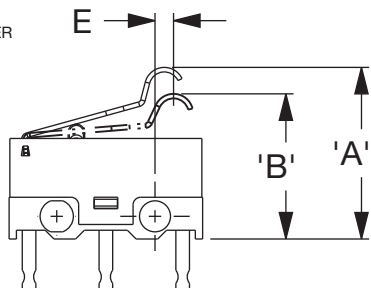

Third Angle
Projection
Dimensions are shown: Inch (mm)
Specifications and dimensions subject to change



Snap-acting

ZMA Series Subminiature Snap-acting Switches

SWITCH CHARACTERISTICS

| CODE | OPER. FORCE MAX. (GRAMS) | | REL. FORCE MIN. (GRAMS) | | 'A' FP MAX. (MM) | 'B' OP MAX. (MM) | 'C' PT MAX. (MM) | 'D' OT MIN. (MM) | 'E' MIN. (MM) |
|--------------|-----------------------------|-----|----------------------------|----|------------------------|------------------------|------------------------|------------------------|---------------------|
| P00 | 80 | 150 | 21 | 35 | 7.35 | 6.9 ±0.3 | 0.62 | 0.2 | |
| S03 | 25 | 43 | 5 | 7 | 14.2 | 9.8 ±0.9 | 3.5 | 0.7 | 5.41 |
| L30 (80gf) | 13 | 21 | 2 | 3 | 16.8 | 9.5 ±1.9 | 6.9 | 0.55 | 20.15 |
| L30 (150 gf) | 13 | 21 | 2 | 3 | 16.8 | 9.75 ±1.9 | 6.9 | 0.55 | 20.15 |
| L11 | 25 | 39 | 4 | 6 | 11.7 | 8.68 ±1 | 4.4 | 0.6 | 7.33 |
| L08 | 27 | 48 | 3 | 8 | 13.5 | 10.75 ±0.8 | 3.5 | 0.3 | 3.82 |
| A03 | 34 | 65 | 6 | 10 | 16.55 | 13.65 ±1 | 3.9 | 0.5 | 0.56 |
| L04 | 30 | 50 | 5 | 8 | 10.1 | 7.9 ±0.7 | 3.0 | 0.5 | 3.49 |
| S06 | 33 | 49 | 5 | 11 | 12.43 | 10.7 ±0.8 | 1.43 | 1.25 | 1.97 |
| S07 | 40 | 65 | 2 | 5 | 13.0 | 9.7 ±1 | 4.3 | 0.5 | 0.49 |

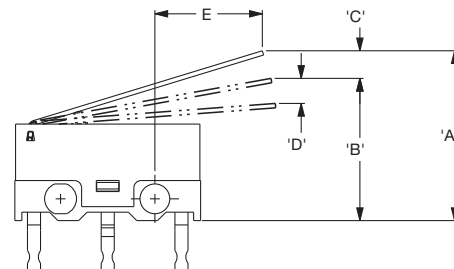

TERMINATIONS

P PC THRU-HOLE

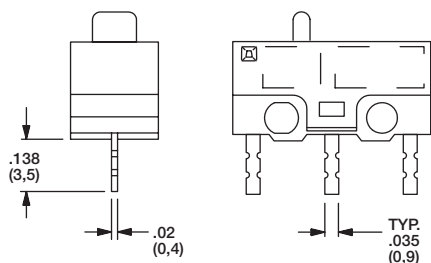

L LEFT FOOTED, PC THRU-HOLE

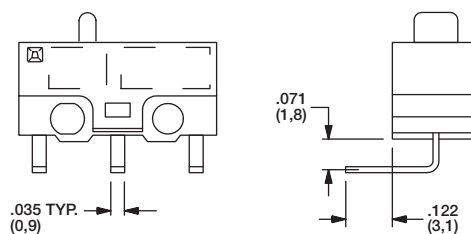

R RIGHT FOOTED, PC THRU-HOLE

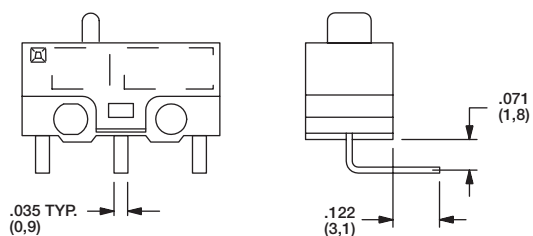

E SOLDER

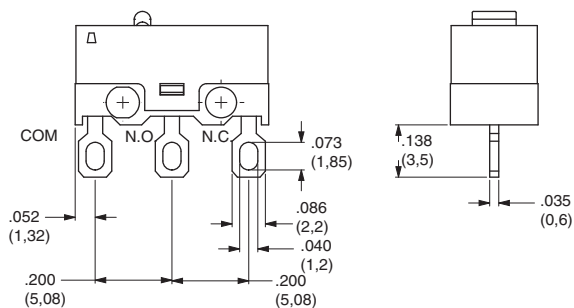

K PC THRU-HOLE WITH RETENTION FEATURE

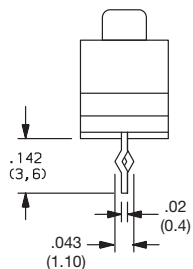

Snap-acting



Third Angle
Projection

Dimensions are shown: Inches (mm)
Specifications and dimensions subject to change

C&K

ZMB Series Subminiature Snap-acting Switches

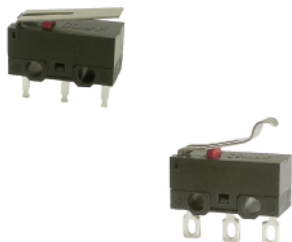

Features/Benefits

- **Compact design**
- **Various operating forces**
- **Different lever options**
- **PCB or solder terminal options**
- **Detect interlock and movement**

Typical Applications

- **Consumer electronics**
- **Communications**
- **Industrial meters**
- **Security systems**
- **Office equipment**

Specifications

CONTACT ARRANGEMENT: SPDT
 CONTACT RATING: 0.1 A @ 30 V DC
 INITIAL CONTACT RESISTANCE: 50 mΩ max.
 INSULATION RESISTANCE: 100 M Ω min. @ 500 VDC
 DIELECTRIC STRENGTH: 1000 VAC (50-60 Hz)
 MECHANICAL LIFE: 500,000 cycles
 ELECTRICAL LIFE: 50,000 cycles
 PRE-TRAVEL: 0.5 mm max.
 OVER-TRAVEL: 0.5 mm min.
 OPERATING TEMPERATURE: -20°C to + 70°C

Materials

COVER / HOUSING: PBT (black)
 KNOB: PBT (red)
 CONTACT: Copper alloy, silver plated
 TERMINALS: Copper alloy, silver plated
 LEVER: Stainless steel

NOTE: Specifications and materials listed above are for switches with standard options. For information on specific and custom switches, consult Customer Service Center.



Snap-acting

Build-A-Switch

To order, simply select desired option from each category and place in the appropriate box. Available options are shown and described on pages J-55 and J-56. For additional options not shown in catalog, consult Customer Service Center.

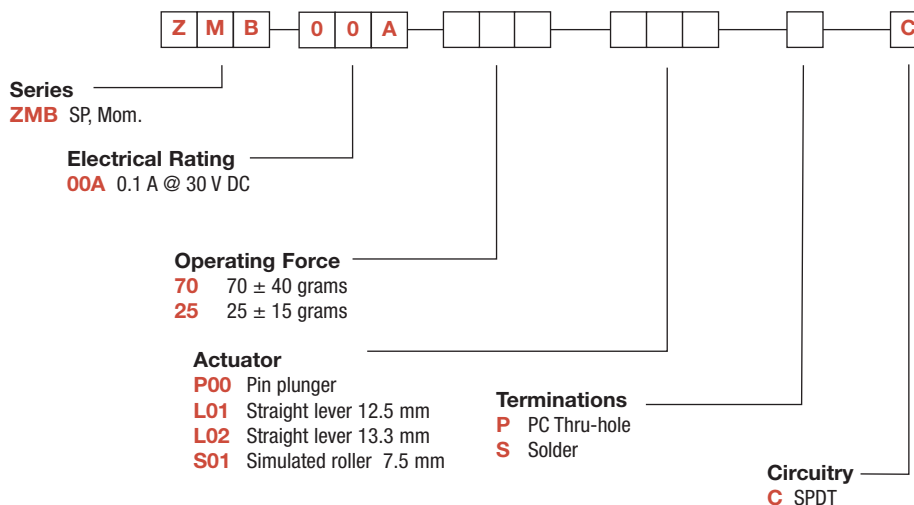

Dimensions are shown: Inch (mm)
 Specifications and dimensions subject to change

ZMB Series Subminiature Snap-acting Switches

ZMB00A70P00PC

PIN PLUNGER, PC THRU-HOLE

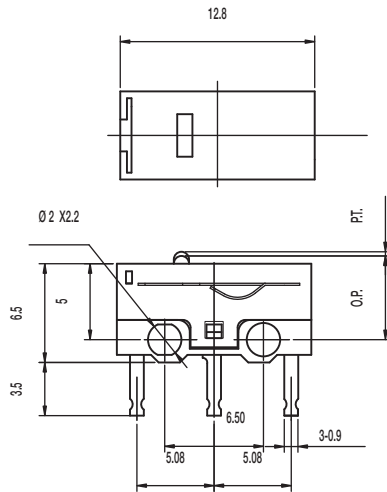

OPERATING FORCE: 70 ± 40 gf
 OPERATING POSITION (OP): 5.5 ± 0.30 mm
 FREE POSITION (FP): N/A

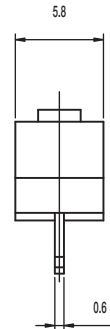

1 P - 2 T

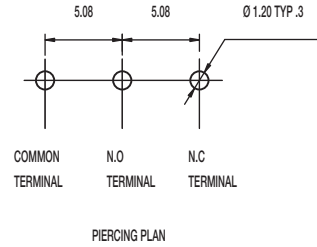
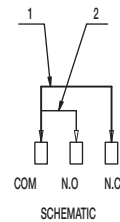

ZMB00A25L01PC

STRAIGHT LEVER 12.5 MM, PC THRU-HOLE

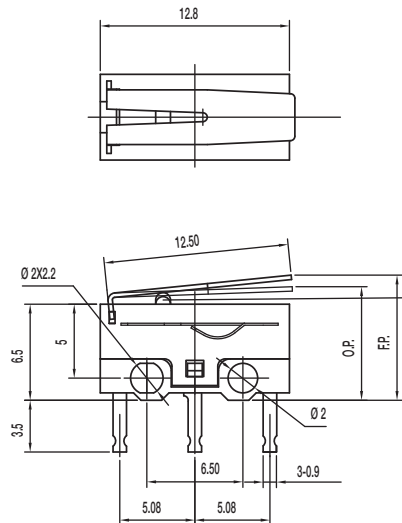

OPERATING FORCE: 25 ± 15 gf
 OPERATING POSITION (OP): 7.2 ± 0.8 mm
 FREE POSITION (FP): 10 mm max.

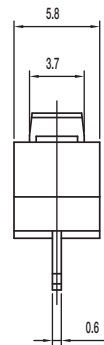

1 P - 2 T

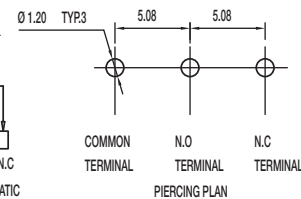
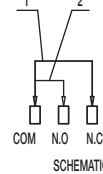

ZMB00A25L02PC

STRAIGHT LEVER 13.3 MM, PC THRU-HOLE

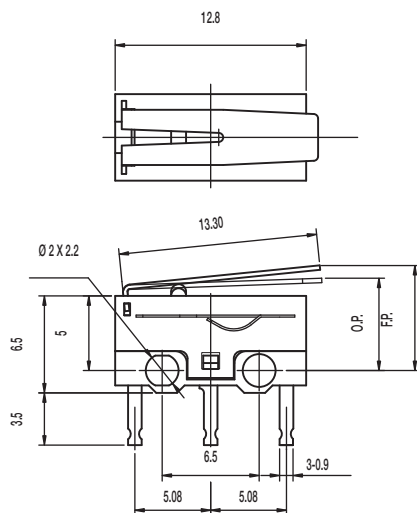

OPERATING FORCE: 25 ± 15 gf
 OPERATING POSITION (OP): 6.0 ± 0.8 mm
 FREE POSITION (FP): 8.5 mm max.

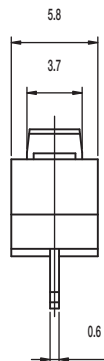

1 P - 2 T

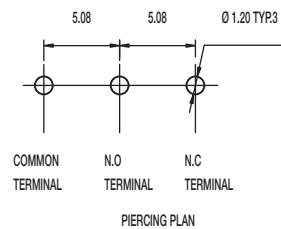
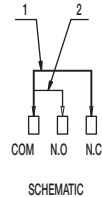

Snap-acting

ZMB Series Subminiature Snap-acting Switches

ZMB00A70P00SC

PIN PLUNGER, SOLDER

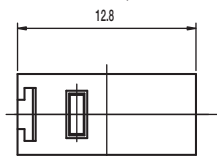

OPERATING FORCE: 70 ± 40 gf
 OPERATING POSITION (OP): 7.0 ± 0.30 mm
 FREE POSITION (FP): N/A

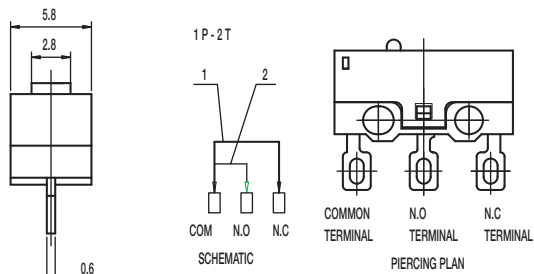
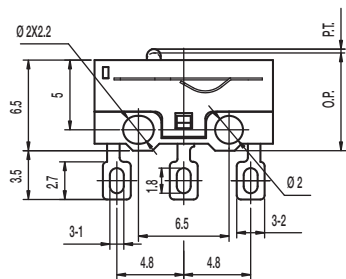

ZMB00A25L02SC

STRAIGHT LEVER 13.3 MM, SOLDER

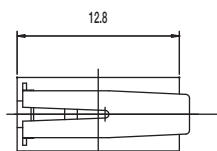

OPERATING FORCE: 25 ± 15 gf
 OPERATING POSITION (OP): 7.5 ± 0.8 mm
 FREE POSITION (FP): 10 mm max.

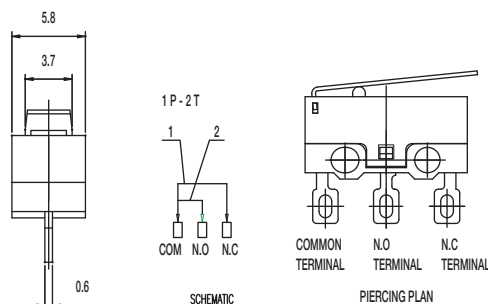
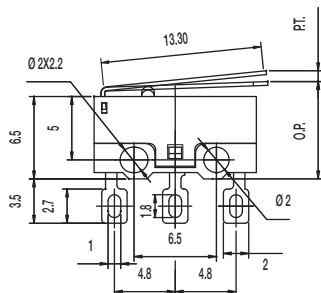

ZMB00A25S01SC

SIMULATED ROLLER 7.5 MM, SOLDER

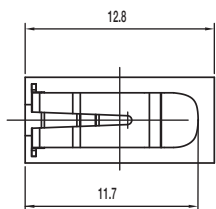

OPERATING FORCE: 25 ± 15 gf
 OPERATING POSITION (OP): 8.5 ± 0.8 mm
 FREE POSITION (FP): 9.5 mm max.

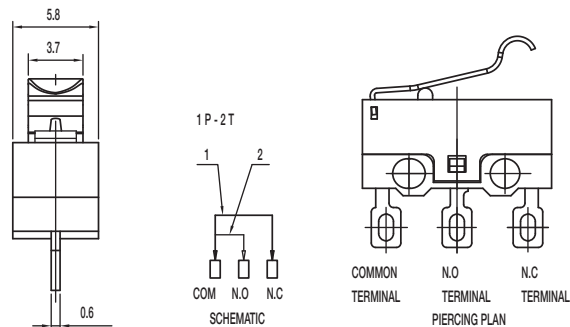
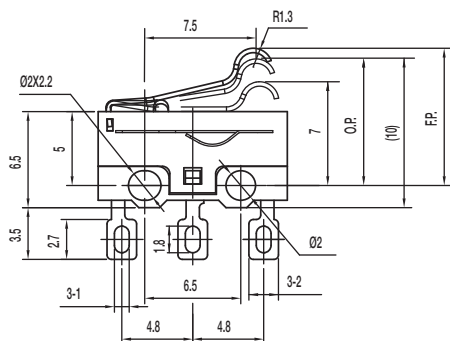

Snap-acting

ZMS Series Subminiature Snap-acting Switches (IP65)

Features/Benefits

- **Reliable snap-acting mechanism**
- **Long electrical and mechanical life**
- **Compact size—Ideal when space is limited**
- **Various PCB terminals and actuators**
- **RoHS compatible**
- **IP67 with potted wires only**

Typical Applications

- **PCB detection switch**
- **Communication devices**
- **Testing equipment**
- **Security/Alarm systems**
- **Consumer electronics**



UL61058-1
UL1054



Specifications

CONTACT RATING: 3A@ 125 V AC/ 3A@ 12 V DC, 0.01A @ 12 V DC
ELECTRICAL LIFE: 100,000 cycles @ 0.01A 12V DC
100,000 cycles @ 3A 12 V DC
6,000 cycles @ 3A 125 V AC
MECHANICAL LIFE: 500,000 cycles
INSULATION RESISTANCE: 100 M ohm min.
DIELECTRIC STRENGTH: 500 Vrms.
OPERATING TEMPERATURE: -40°C + 85°C.
OPERATING FORCE: 130 grams.

* Low Level=conditions where no arcing occurs during switching, i.e., 0.4 VA max.
@ 20 V AC or DC max.

Materials

CASE: Nylon
COVER/ACTUATOR: PBT
MOVABLE CONTACTS: 3 Amp silver alloy, 0.01A gold plating over silver alloy
STATIONARY CONTACTS: 3 Amp silver alloy, 0.01 A gold plating over silver alloy
TERMINALS: Brass, silver plated
LEVER: Stainless steel

NOTE: Specifications and materials listed above are for switches with standard options. For information on specific and custom switches, consult Customer Service Center.

Build-A-Switch

To order, simply select desired option from each category and place in the appropriate box. Available options are shown and described on pages J-58 through J-60. For additional options not shown in catalog, consult Customer Service Center.

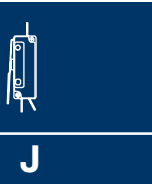
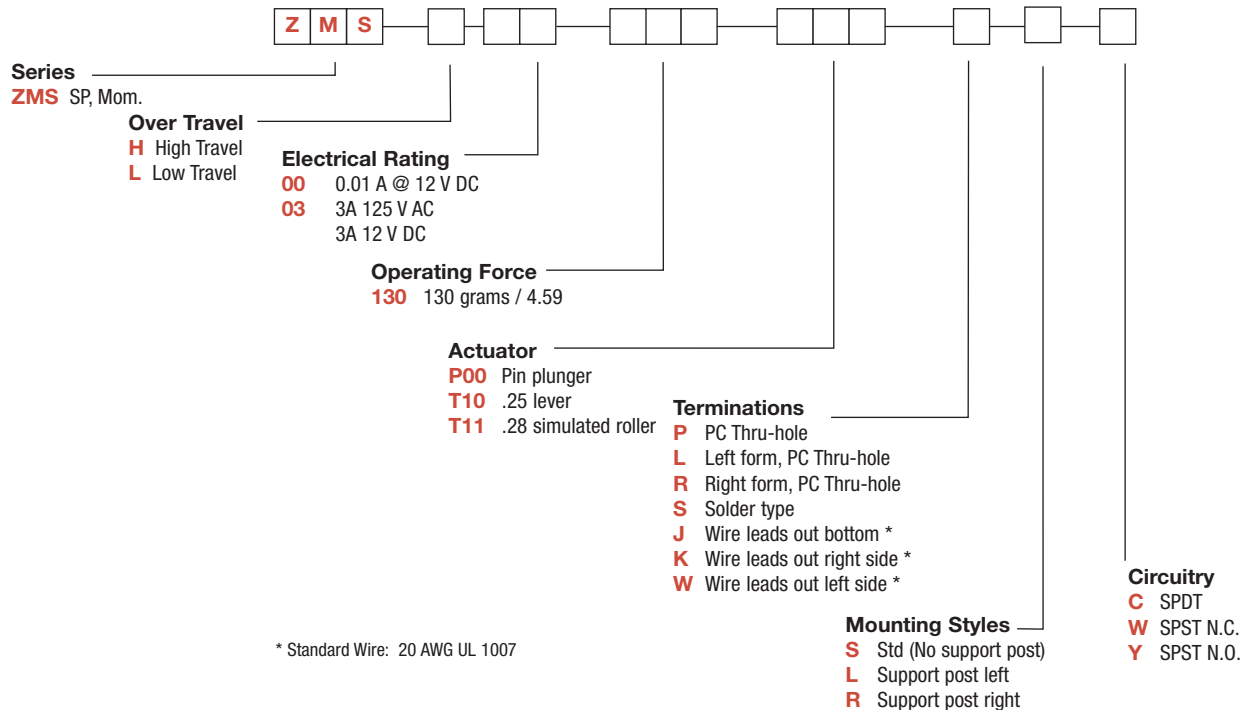

Snap-acting



Dimensions are shown: Inches (mm)
Specifications and dimensions subject to change

ZMS Series Subminiature Snap-acting Switches (IP65)

ACTUATOR

P00 PIN PLUNGER (IP65)

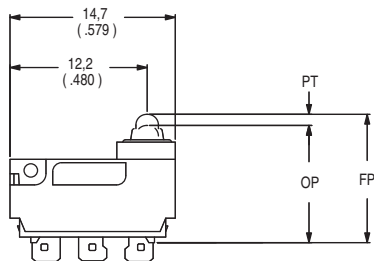

C&K US approved

T10 .25 LEVER (IP65)

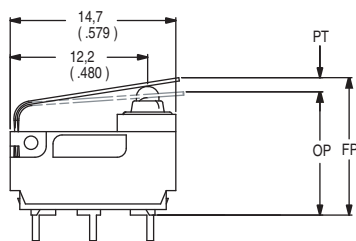

T11 LEVER (IP65)

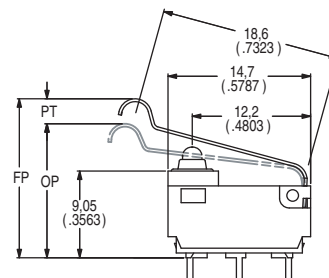

SWITCH CHARACTERISTICS

| Actuator code | Maximum Operate Force (grams/oz.) | Minimum Release Force (grams/oz.) | Free Position Max | Maximum Pre-travel | Operate Position | Maximum Differential | Low Overtravel min. (L) | High Overtravel min. (H) |
|---------------|-----------------------------------|-----------------------------------|-------------------|--------------------|-----------------------------|----------------------|-------------------------|--------------------------|
| P00 | 130 4.59 | 13 0.45 | .472 (12) | 0.032 (0,8) | .415 ± .012 (10.55 ± .3) | .012 (0,3) | 0.031 (0,8) | 0.068 (1,72) |
| T10 | 195 6.88 | 55 1.93 | .604 (15.35) | 0.152 (3.85) | .440 ± .020 (11.2 ± .5) | 0.020 (0,5) | 0.053 (1,35) | 0.084 (2,14) |
| T11 | 160 5.64 | 45 1.58 | .726 (18.45) | 0.186 (4.8) | .539 ± .032 (13.7 ± .8) | 0.030 (0,7) | 0.062 (1,65) | 0.101 (2,57) |

P00 PIN PLUNGER (IP67)

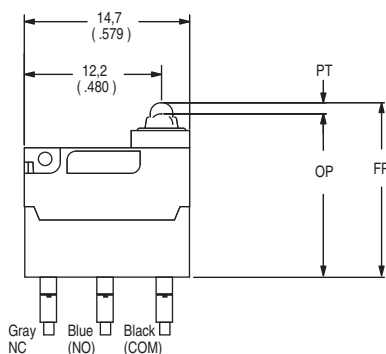

T10 .25 LEVER (IP67)

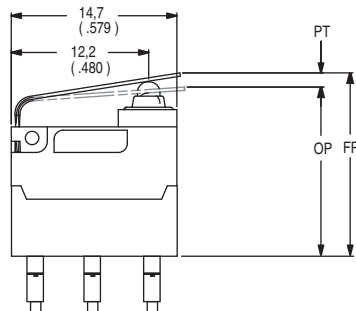

T11 .28 LEVER (IP67)

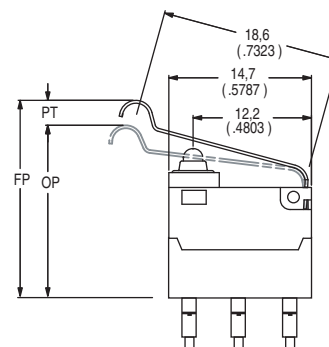

SWITCH CHARACTERISTICS "J" TERMINATION ONLY

| Actuator code | Maximum Operate Force (grams/oz.) | Minimum Release Force (grams/oz.) | Free Position Max | Maximum Pre-travel | Operate Position | Maximum Differential | Low Overtravel min. (L) | High Overtravel min. (H) |
|---------------|-----------------------------------|-----------------------------------|-------------------|--------------------|------------------------------|----------------------|-------------------------|--------------------------|
| P00 | 130 4.59 | 13 0.45 | .650 (16.50) | 0.032 (0,8) | .593 ± .020 (15.05 ± 0.5) | .012 (0,3) | 0.031 (0,8) | 0.068 (1,72) |
| T10 | 195 6.88 | 55 1.93 | .781 (19.85) | 0.152 (3.85) | .618 ± .028 (15.7 ± .7) | 0.020 (0,5) | 0.053 (1,35) | 0.084 (2,14) |
| T11 | 160 5.64 | 45 1.58 | .904 (22.95) | 0.188 (4.8) | .717 ± .039 (18.2 ± 1.0) | 0.030 (0,7) | 0.062 (1,65) | 0.101 (2,57) |



Snap-acting



Third Angle Projection

Dimensions are shown: mm (inch)
Specifications and dimensions subject to change



ZMS Series Subminiature Snap-acting Switches (IP65)

TERMINATIONS

P PC THRU-HOLE

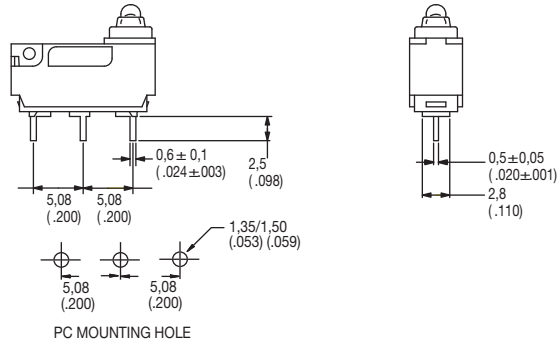

L LEFT FOOTED, PC THRU-HOLE

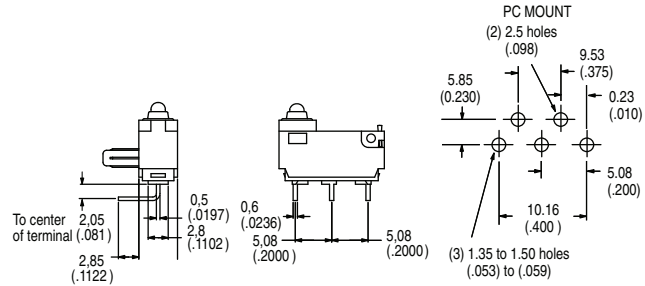

R RIGHT FOOTED, PC THRU-HOLE

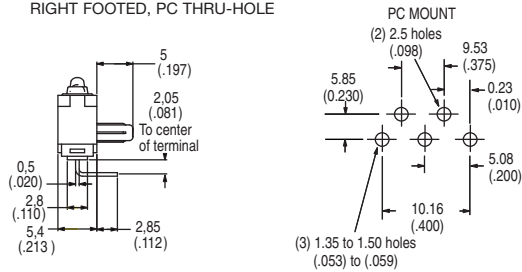

J WIRE LEADS BOTTOM (IP67)

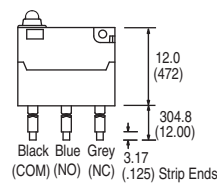

K RIGHT SIDE (IP67)

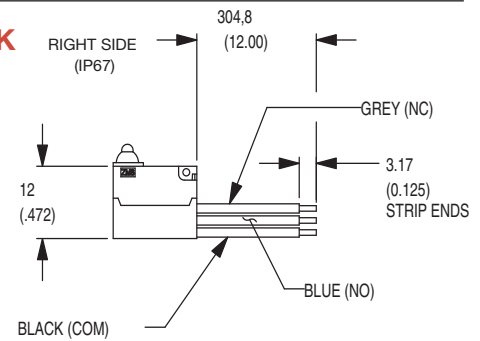

S SOLDER TYPE

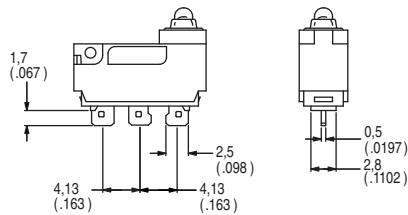

W LEFT SIDE (IP67)

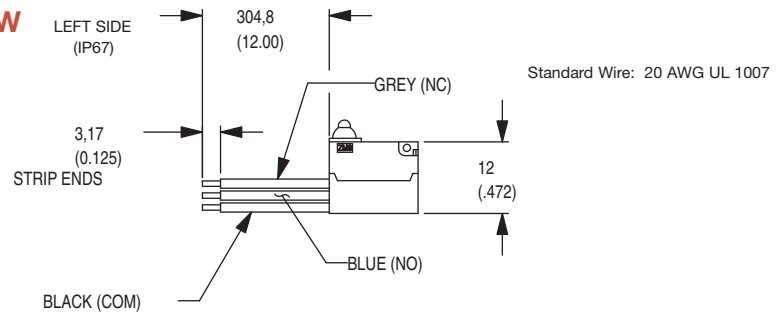

MOUNTING STYLES

S STD (NO SUPPORT POST)

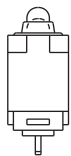

L SUPPORT POST LEFT

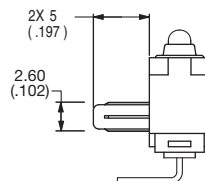

R SUPPORT POST RIGHT

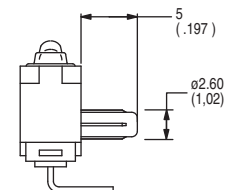

CIRCUITRY

C SPDT (Single Pole, Double Throw)

W SPST, NC (Single Pole, Single Throw, Normally Closed)

Y SPST, NO (Single Pole, Single Throw, Normally Open)

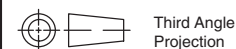

Third Angle
Projection

Dimensions are shown: mm (inch)
Specifications and dimensions subject to change

C&K

ZMSM Series with Mounting Hole Subminiature Snap-acting Switches (IP65)

Features/Benefits

- Reliable snap-acting mechanism
- Long electrical and mechanical life
- Various PCB terminals and actuators
- RoHS compatible
- IP67 with potted wires only

Typical Applications

- Communication devices
- Testing equipment
- Security/Alarm systems

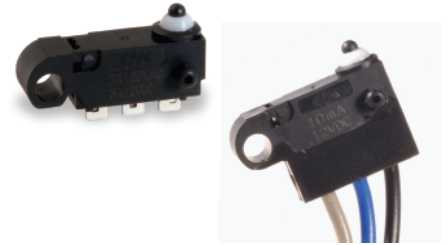

UL61058-1  US

Specifications

CONTACT RATING: 3A@ 125 V AC/ 3A@ 12 V DC, 0.01 A@ 12 V DC.

ELECTRICAL LIFE: 100,000 cycles @ 0.01 A, 12 V DC / 100,000 cycles @ 3A, 12 V DC, 6,000 cycles @ 3A, 125 VAC

INSULATION RESISTANCE: 100 M ohm min.

DIELECTRIC STRENGTH: 500 Vrms.

OPERATING TEMPERATURE: see chart below.

OPERATING FORCE: 130 grams.

* Low Level=conditions where no arcing occurs during switching, i.e., 0.4 VA max. @ 20 V AC or DC max.

Materials

CASE: Nylon

COVER/ACTUATOR: PBT

MOVABLE CONTACTS: 3 Amp silver, 0.01A gold

STATIONARY CONTACTS: 3 Amp silver, 0.01A gold

TERMINALS: Brass, Pre-plated with silver

LEVER: Stainless steel

NOTE: Specifications and materials listed above are for switches with standard options. For information on specific and custom switches, consult Customer Service Center.

Build-A-Switch

To order, simply select desired option from each category and place in the appropriate box. Available options are shown and described on pages J-62 through J-64. For additional options not shown in catalog, consult Customer Service Center.

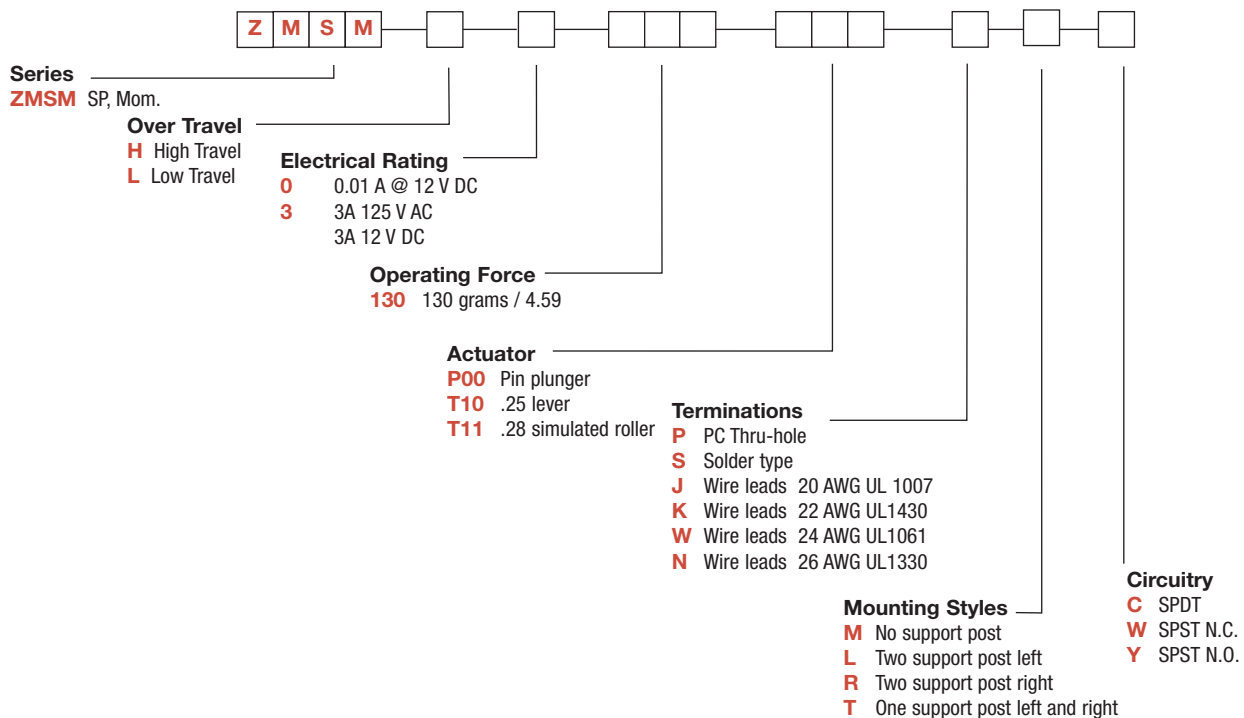

Dimensions are shown: mm
 Specifications and dimensions subject to change



Snap-acting

ZMSM Series with Mounting Hole Subminiature Snap-acting Switches (IP65)

SERIES

ZMSMH HIGH OVER TRAVEL

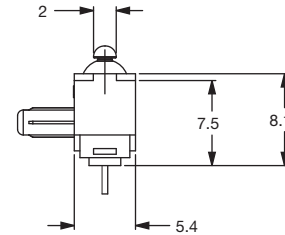
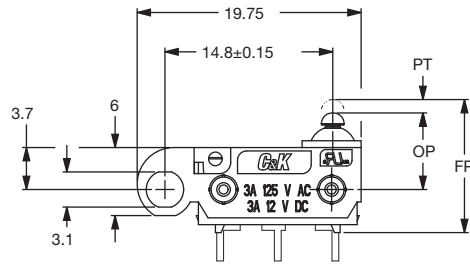
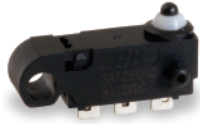

ZMSML LOW OVER TRAVEL

MODEL SHOWN: ZMSMHXXXXP00PLC

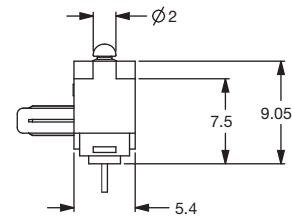
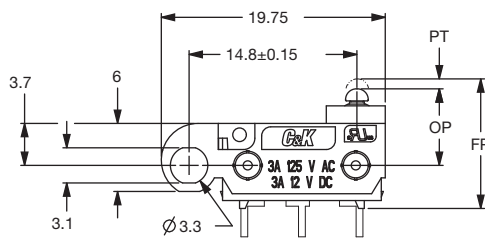

MODEL SHOWN: ZMSMLXXXXP00PLC



Snap-acting

ELECTRICAL RATING

| OPTION CODE | RoHS COMPLIANT* | RoHS COMPATIBLE* | CONTACT MATERIAL | | ELECTRICAL RATING |
|-------------|-----------------|------------------|------------------|--------------------|---------------------------------------|
| | | | MOVABLE CONTACT | STATIONARY CONTACT | |
| 0 | Yes | Yes | Gold alloy | | 0.01 A @ 12 V DC |
| 3 | Yes | Yes | Silver alloy | | 3 AMPS @ 125 V AC 3 AMPS @ 12 V DC |

Model **C&K** with option "S" (solder type) only.
Consult Customer Service center for availability and delivery of nonstandard ratings.

OPERATING FORCE

| OPTION CODE | BASIC SWITCH OPERATING FORCE (OZ./GRAMS) |
|-------------|--|
| 130 | 130 4.59 |



Dimensions are shown: mm
Specifications and dimensions subject to change



ZMSM Series with Mounting Hole Subminiature Snap-acting Switches (IP65)

ACTUATOR

P00 PIN PLUNGER (IP65)

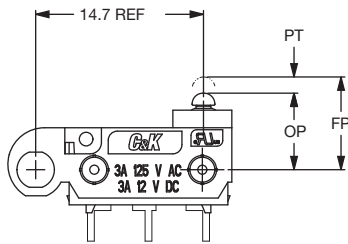

MODEL SHOWN: ZMSMLXXXP00PLC

T10 .25 LEVER (IP65)

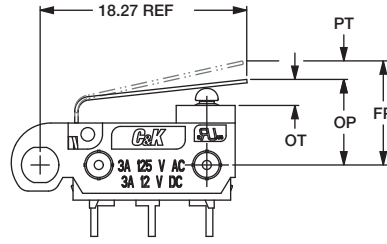

MODEL SHOWN: ZMSMLXXXT10PLC

T11 LEVER (IP65)

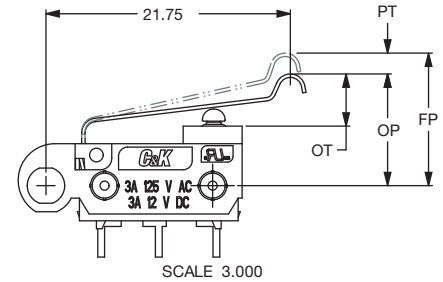

MODEL SHOWN: ZMSMLXXXT11PLC

SWITCH CHARACTERISTICS

| Actuator code | Maximum Operate Force (grams/oz.) | Minimum Release Force (grams/oz.) | Free Position Max (mm) | Maximum Pre-travel (mm) | Operate Position (mm) | Maximum Differential (mm) | Low Overtravel min. (mm) | High Overtravel min. (mm) |
|---------------|-----------------------------------|-----------------------------------|------------------------|-------------------------|-----------------------|---------------------------|--------------------------|---------------------------|
| P00 | 130 4.59 | 13 0.45 | 7.35 | 0.8 | 6.75 ± 0.3 | 0.3 | 0.8 | 1.75 |
| T10 | 195 6.88 | 55 1.93 | 10.70 | 3.85 | 7.40 ± 0.8 | 0.5 | 1.35 | 2.3 |
| T11 | 160 5.64 | 45 1.58 | 13.80 | 4.8 | 9.90 ± 0.8 | 0.7 | 1.65 | 2.6 |

TERMINATIONS

P PC THRU-HOLE (IP65)

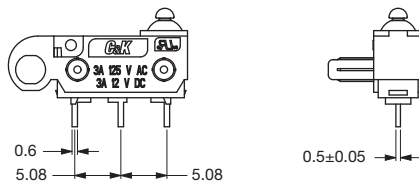

MODEL SHOWN: ZMSMHXXXP00PLC

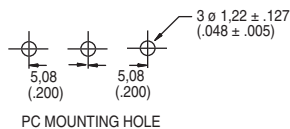

PC MOUNTING HOLE

S SOLDER TYPE (IP65)

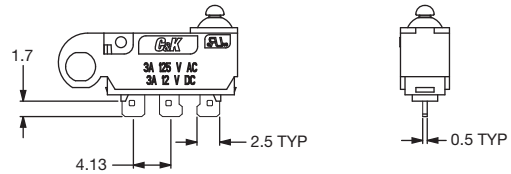

MODEL SHOWN: ZMSMHXXXP00SMC

J WIRE LEADS BOTTOM (IP67)

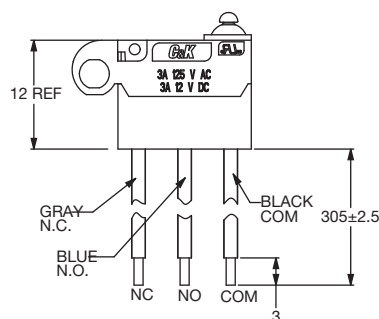

Standard Wire: 20 AWG UL 1007

Available options - must specify

22AWG UL1430

24AWG UL1061

26AWG UL1330



Third Angle Projection

Dimensions are shown: mm
Specifications and dimensions subject to change

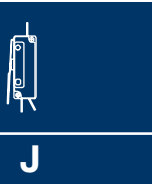

Snap-acting

ZMSM Series with Mounting Hole Subminiature Snap-acting Switches (IP65)

MOUNTING STYLES

M NO SUPPORT POSTS

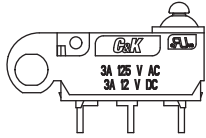
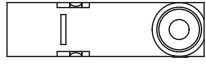

MODEL SHOWN:
ZMSMHXXXXP00PMC

L TWO SUPPORT POSTS LEFT

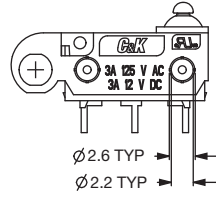
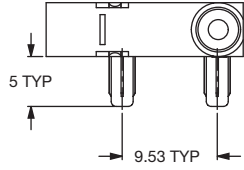

POSTS LEFT
MODEL SHOWN:
ZMSMHXXXXP00PLC

R TWO SUPPORT POSTS RIGHT

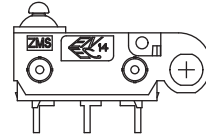
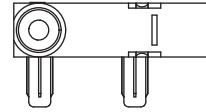

POSTS RIGHT
MODEL SHOWN:
ZMSMHXXXXP00PRC

T ONE SUPPORT POST
LEFT & RIGHT

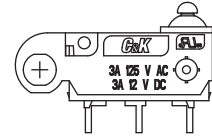
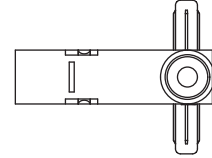

LEFT & RIGHT
MODEL SHOWN:
ZMSMHXXXXP00PTC



Snap-acting

CIRCUITRY

- C** SPDT (Single Pole, Double Throw)
- W** SPST, NC (Single Pole, Single Throw, Normally Closed)
- Y** SPST, NO (Single Pole, Single Throw, Normally Open)

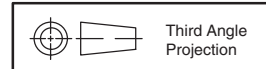

Dimensions are shown: mm
Specifications and dimensions subject to change

MDS Series Micro Snap-acting Detect Switches

Features/Benefits

- Snap-acting tactile feel
- Small package size
- Available in vertical or right angle PCB mount
- RoHS compliant and compatible

Typical Applications

- Detect the presence of a mechanical device
- Medical devices
- Consumer electronic devices
- ATCA applications

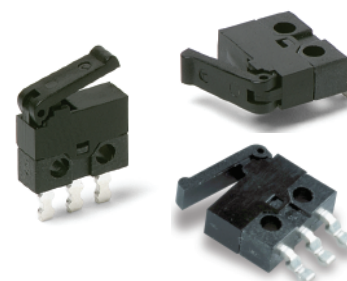

Specifications

CONTACT RATING: 300mA @ 30 VDC.
 MECHANICAL & ELECTRICAL LIFE: 30,000 operations.
 CONTACT RESISTANCE: 100 m Ω max. initial
 OPERATING TEMPERATURE: -25°C to +70°C.
 SOLDERABILITY: According to lead free solder profiles.
 PACKAGING: Available in bulk or tape and reel.
 OPERATING FORCE: 50g Max.
 RELEASE FORCE: 3g Min.

Materials

BASE: PA9T
 COVER & ACTUATOR: PA9T
 MOVABLE CONTACT: Copper alloy, silver plated.
 STATIONARY CONTACTS: Copper alloy, silver plated.
 TERMINALS: Copper alloy, silver plated.

NOTE: MDS series is RoHS compliant, and compatible. See technical data section of this catalog for RoHS compliant and compatible definitions and specifications.

NOTE: Specifications and materials listed above are for switches with standard options. For information on specific and custom switches, consult Customer Service Center.



Build-A-Switch

To order, simply select desired option from each category and place in the appropriate box. Available options are shown and described on pages J-66 through J-70. For additional options not shown in catalog, consult Customer Service Center.

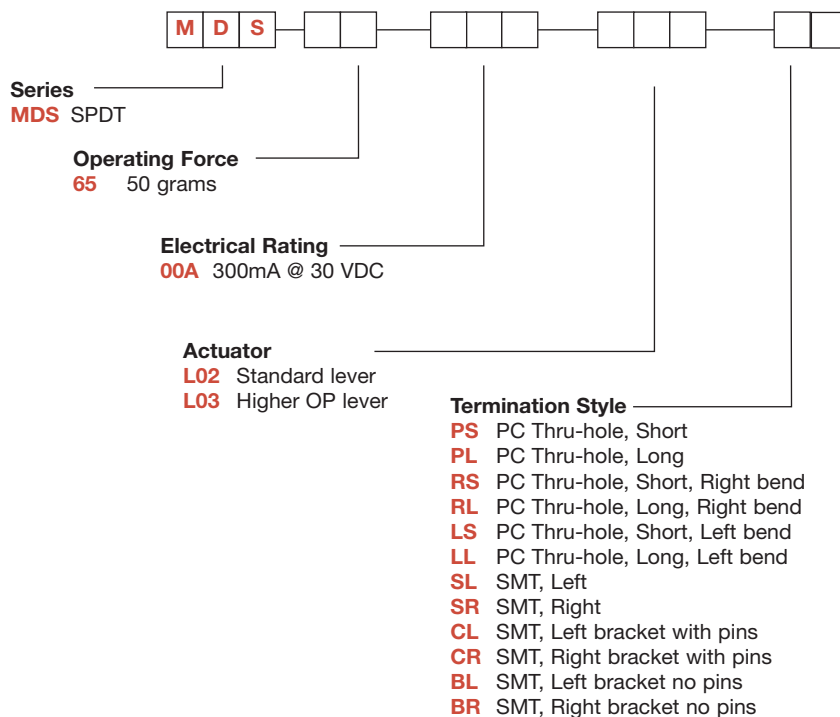

Snap-acting

MDS Series Micro Snap-acting Detect Switches

SERIES MDS ■■■■■■■■

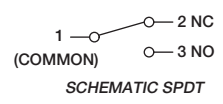
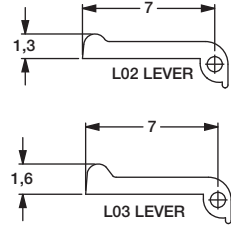
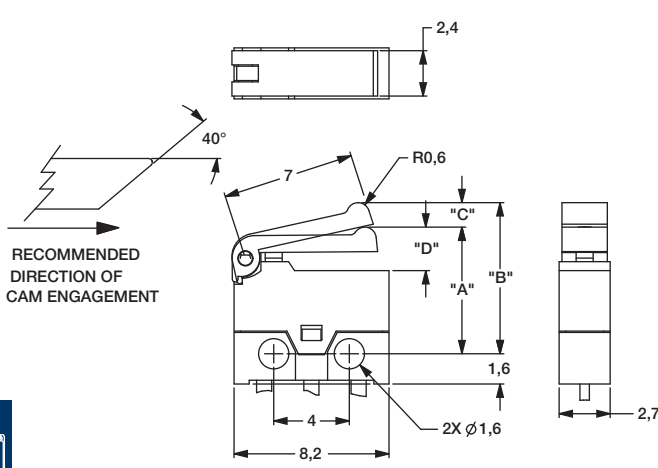

| OPERATING CHARACTERISTICS | | | |
|---------------------------|---------|-----------------|-----------------|
| | | LEVER L02 | LEVER L03 |
| OPERATING POSITION | DIM 'A' | 6.7±0.5 | 7.0 +/-0.5 |
| FREE POSITION | DIM 'B' | 8 MAX | 8.5 MAX |
| PRETRAVEL | DIM 'C' | 1.8 MAX | 1.8 MAX |
| OVER TRAVEL | DIM 'D' | 0.3 MIN | 0.3 MIN |
| CONTACT RATING | | 0.3A @ 30 VDC | 0.3A @ 30VDC |
| OPERATING FORCE | | 50 GRAMS F. MAX | 50 GRAMS F. MAX |

Snap-acting

OPERATING FORCE ■■■■■■■■

| OPTION CODE | OPERATING FORCE |
|-------------|-----------------|
| 65 | 50 grams max. |

ELECTRICAL RATING ■■■■■■■■

| OPTION CODE | ELECTRICAL RATING |
|-------------|-------------------|
| 00A | 300mA @ 30 V DC |

ACTUATOR ■■■■■■■■

L02 STANDARD LEVER

L03 HIGHER OP LEVER

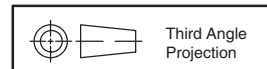

Dimensions are shown: mm
Specifications and dimensions subject to change

MDS Series Micro Snap-acting Detect Switches

TERMINATIONS

PCB Mounting Pattern

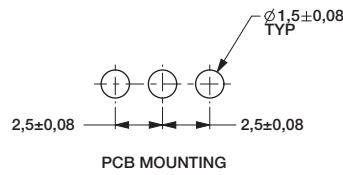

PS PC THRU-HOLE, SHORT STRAIGHT

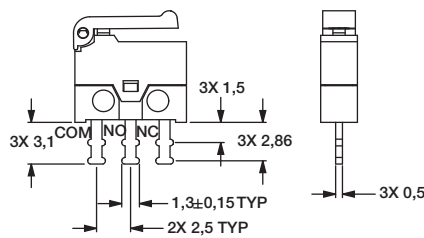

PL PC THRU-HOLE, LONG STRAIGHT

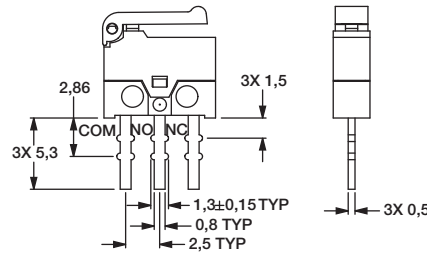

RS PC THRU-HOLE, SHORT RIGHT BEND

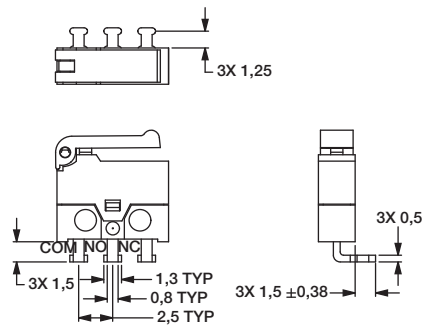

RL PC THRU-HOLE, LONG SHORT BEND

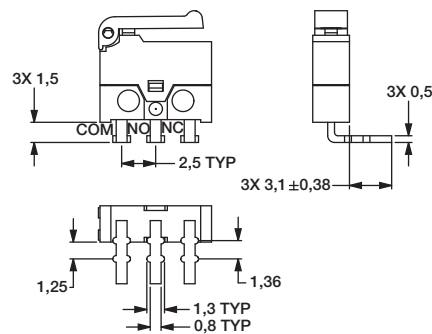

LS PC THRU-HOLE, SHORT LEFT BEND

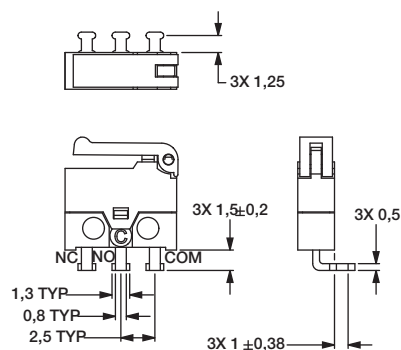

LL PC THRU-HOLE, LONG LEFT BEND

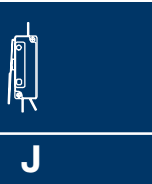
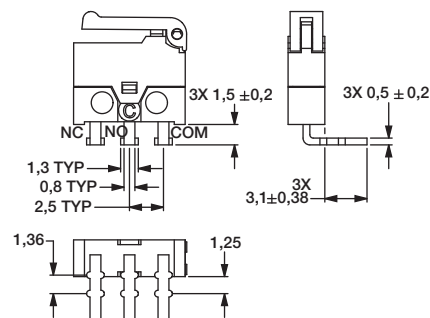

Snap-acting

MDS Series Micro Snap-acting Detect Switches

TERMINATIONS

SL SMT, LEFT MOUNT

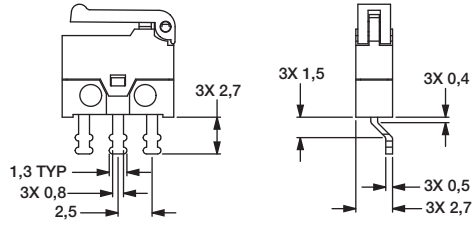

SMT Mounting Pattern

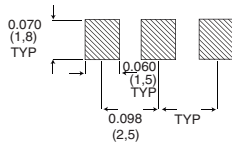

SR SMT, RIGHT MOUNT

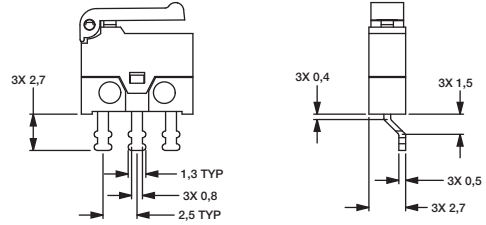

SMT Mounting Pattern

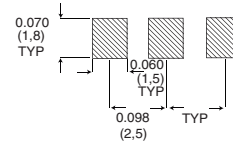

CL SMT, LEFT BRACKET WITH PINS

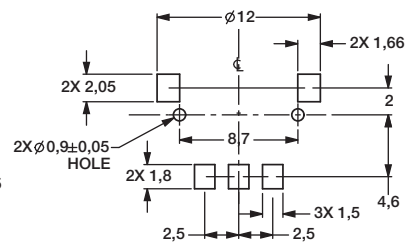
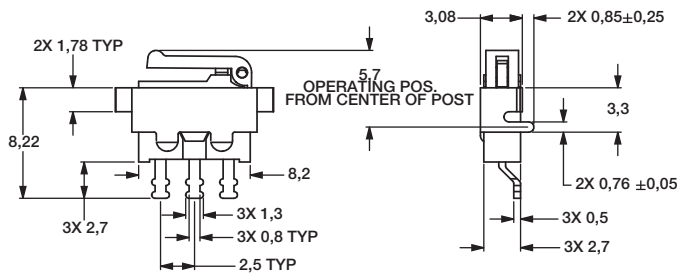
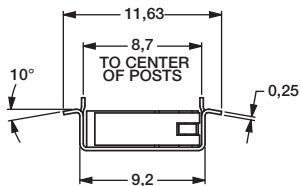

CR SMT, RIGHT BRACKET WITH PINS

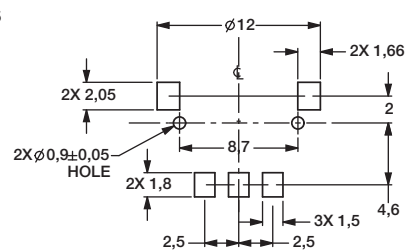
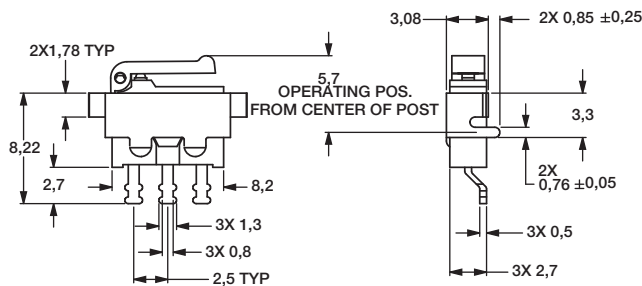
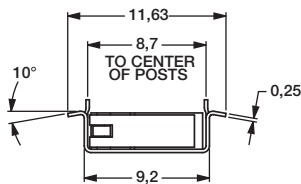

Snap-acting



Snap-acting

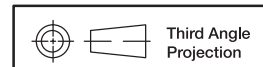

Dimensions are shown: mm
Specifications and dimensions subject to change

MDS Series Micro Snap-acting Detect Switches

TERMINATIONS

BL SMT, LEFT BRACKET NO PINS

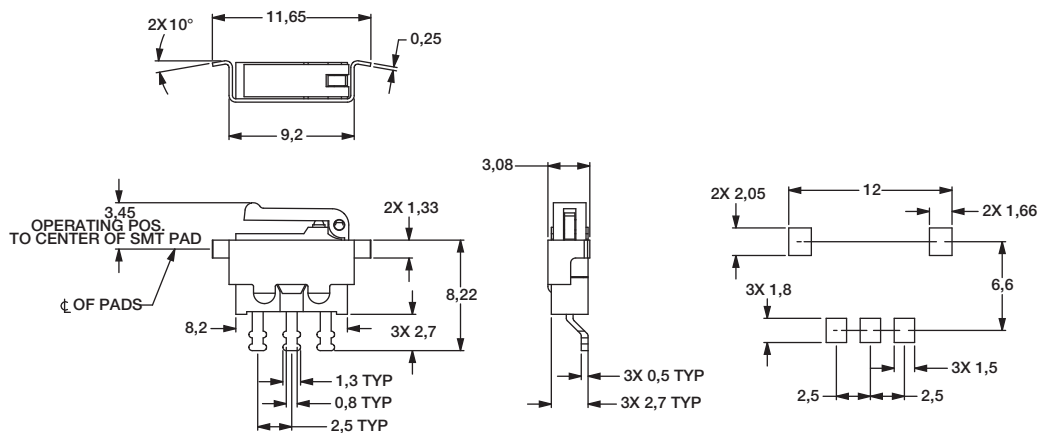

BR SMT, RIGHT BRACKET NO PINS

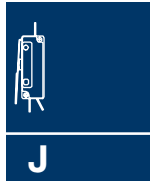
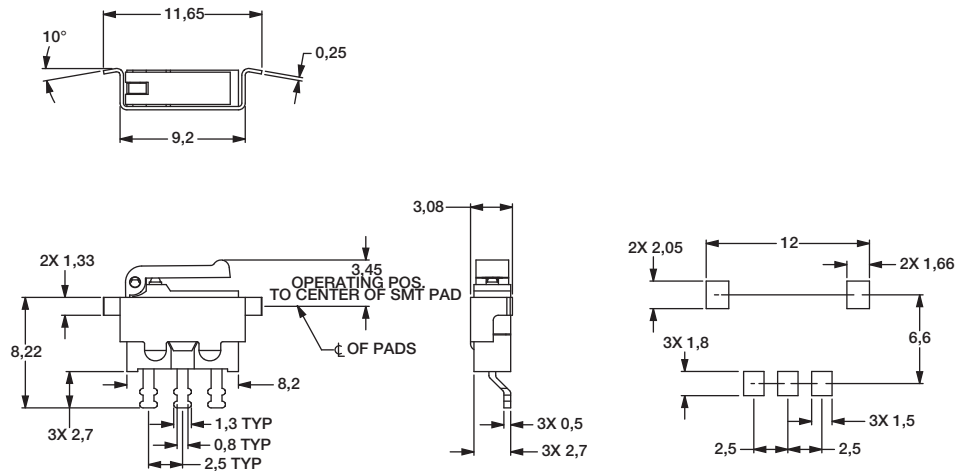

Snap-acting

MDS Series Micro Snap-acting Detect Switches

TAPE AND REEL

SL SMT, LEFT MOUNT

SR SMT, RIGHT MOUNT

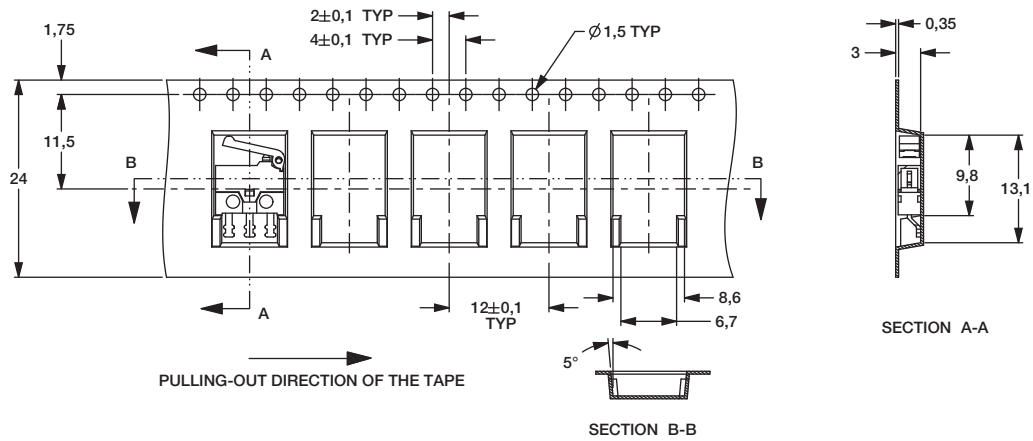

Snap-acting

CL SMT, LEFT MOUNT

CR SMT, RIGHT MOUNT

BL SMT, LEFT MOUNT

BR SMT, RIGHT MOUNT

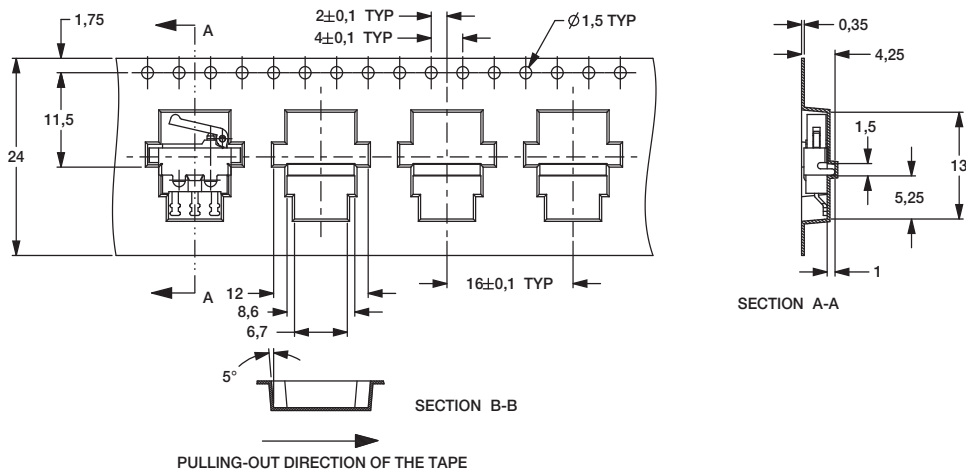

Supplied in carrier tape meeting the EIA-481-2 standard for 24mm tape.

Packaging quantity: SL and SR; 1,600 pieces per reel
CL, CR, BL and BR; 1,000 pieces per reel

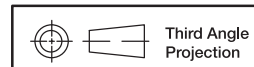

Dimensions are shown: mm
Specifications and dimensions subject to change

HB Series Single Pole Standard Precision Snap-acting Switches

Features/Benefits

- Low differential travel, high repeatability
- Long life—150,000 cycles typical
- Single and double pole circuitry
- Sealed actuator and case

Typical Applications

- Thermostats
- Motors
- Industrial controls



Specifications

CONTACT RATING: From low level* to 20 AMPS @ 480 V AC; see ELECTRICAL RATING option section for complete listings.
 ELECTRICAL LIFE: 150,000 cycles at 20 AMPS @ 250 V AC. consult Customer Service Center for typical life at other ratings.
 INSULATION RESISTANCE: 1,000 M ohm min.
 DIELECTRIC STRENGTH: 1,500 Vrms min. @ sea level.
 OPERATING TEMPERATURE: -67°F to 302°F (-55°C to 150°C).
 OPERATING FORCE: From 4 oz. to 26 oz. max. at actuator button available.
 MOUNTING SCREWS: Torque 3 in/lbs max.
 (Note: Exceeding 3 in/lbs torque may change operating characteristics and increase the possibility of cracking switch case).
 TERMINAL SCREWS: Torque 4 in/lbs max.
 PANEL MOUNTING BUSHING: Torque 4-6 in/lbs max.
 DEGREE OF PROTECTION: IP65; Dust-proof, water splash and dew condensation.

* Low Level=conditions where no arcing occurs during switching, i.e., 0.4 VA max. @ 20 V AC or DC max.

Materials

SWITCH HOUSING: Heat resistant/electrical grade phenolic.
 INSERTS: Brass alloy.
 ACTUATOR BUTTON: Moisture resistant phenolic.
 SPRING: Copper alloy.
 PIVOT: Brass alloy.
 MOVABLE CONTACTS: Gold alloy for ratings 1 AMP or less. Fine silver for ratings greater than 1 AMP and motor load ratings less than 1/2 HP @ 125 V AC. Silver alloy for motor load ratings 1/2 HP @ 125 V AC or greater.
 STATIONARY CONTACTS: Gold alloy for ratings 1 AMP or less. Fine silver welded to copper base for ratings greater than 1 AMP and motor load ratings less than 1/2 HP @ 125 V AC. Silver alloy on copper base for motor load ratings 1/2 HP @ 125 V AC or greater.
 TERMINALS: Brass alloy, bright tin plated.

NOTE: Specifications and materials listed above are for switches with standard options. For information on specific and custom switches, consult Customer Service Center.

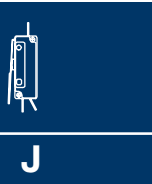

Snap-acting

Build-A-Switch

To order, simply select desired option from each category and place in the appropriate box. Available options are shown and described on pages J-72 through J-76. For additional options not shown in catalog, consult Customer Service Center.

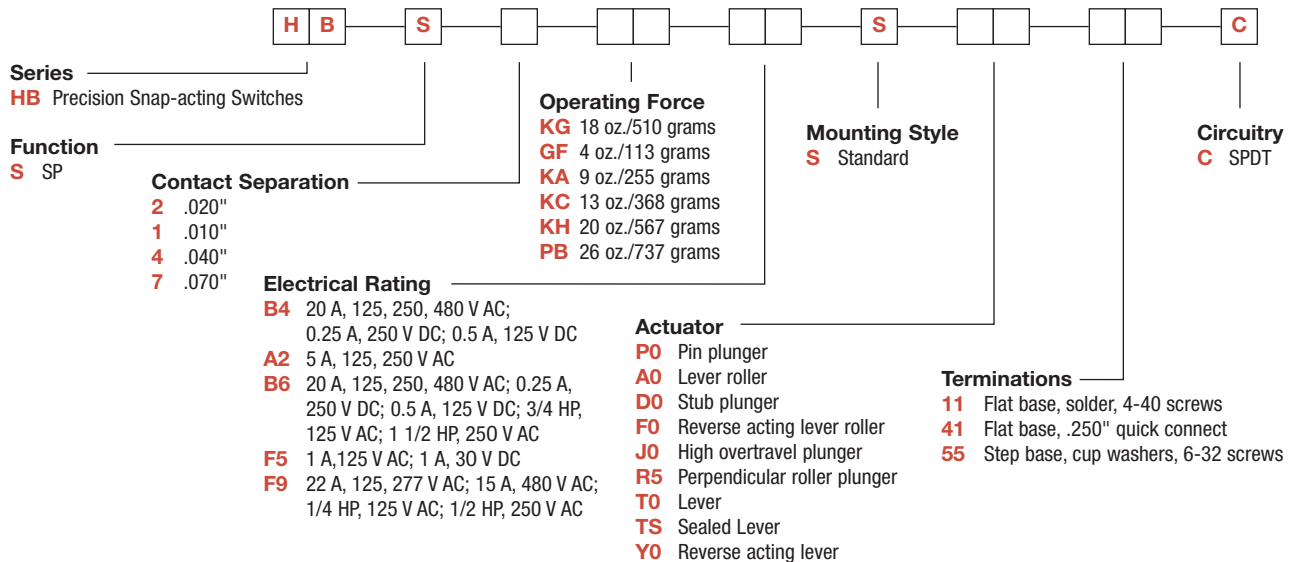

Dimensions are shown: mm
 Specifications and dimensions subject to change

HB Series Single Pole Standard Precision Snap-acting Switches

Sealed Actuator and Case

To provide reliable service under environmental conditions that might damage standard precision switches, various HB Series switch models are sealed against the entrance of airborne contaminants and/or splashing liquids. The clearance between the operating plunger and the cover is sealed with a silicone boot and the base cover joint is sealed with an epoxy adhesive. These models are designed to meet requirements of IP65 (dust proof, water splash and dew condensation). For additional information on sealed switches, consult our Customer Service Center.

SERIES

HB PRECISION SNAP-ACTING SWITCHES

FUNCTION

S SINGLE POLE SWITCH



Snap-acting

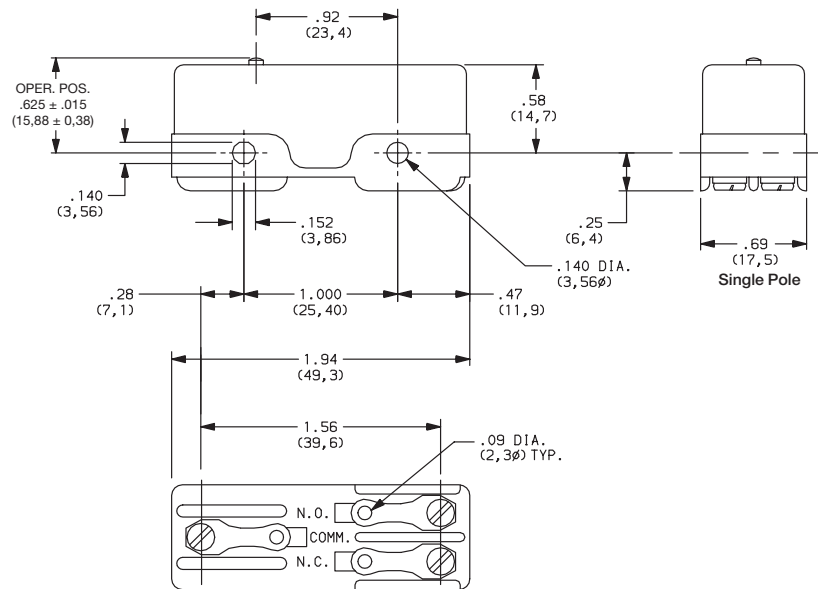

NOTE: To select switching function, see CIRCUITRY section, page J-52.

CONTACT SEPARATION

| OPTION CODE | NOMINAL CONTACT SEPARATION (in./mm) |
|-------------|-------------------------------------|
| 2 | .020 (0,51) |
| 1 | .010 (0,25) |
| 4 | .040 (1,02) |
| 7 | .070 (1,78) |

Switches with 1 AMP rating (option code 'F5') are available only with .020 contact separation (option '2').
Switches with 1/2 HP, 125 V AC rating or greater (option codes 'B5 and B6') are not available with .010 contact separation (option code '1').

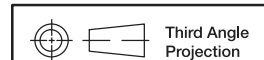
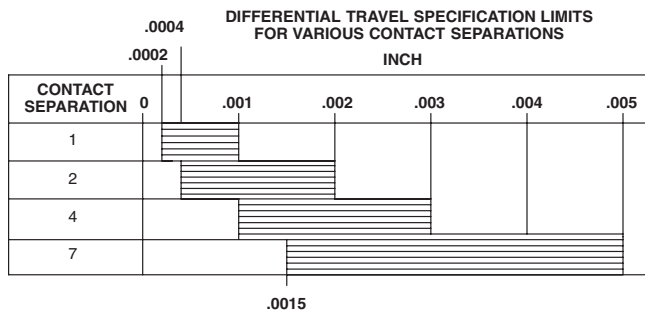

Dimensions are shown in (mm)

Specifications and dimensions subject to change



HB Series Single Pole Standard Precision Snap-acting Switches

OPERATING FORCE

| OPTION CODE | MAXIMUM OPERATING FORCE (OZ./GRAMS) | STANDARD CONTACT SEPARATION (inch) |
|-------------|-------------------------------------|------------------------------------|
| KG | 18 510 | .020 |
| GF | 4 115 | .010 |
| KA | 9 255 | .010 |
| KC | 13 370 | .020 |
| KH | 20 570 | .040 |
| PB | 26 740 | .070 |

OPERATING FORCE SPECIFICATION LIMITS FOR VARIOUS CONTACT SEPARATIONS

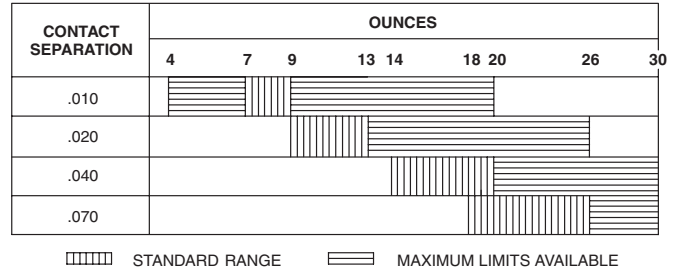

NOTE: All listed differential travel characteristics are based on standard operating force and contact separation. For any other force or contact separation, consult Customer Service Center.
Operating force varies with actuator option, see ACTUATOR option section.

ELECTRICAL RATING

| OPTION CODE | MOVABLE CONTACT | STATIONARY CONTACT | ELECTRICAL RATING |
|-------------|-----------------------|------------------------------------|--|
| B4 | Fine silver. | Fine silver welded to copper base. | 20 AMPS @ 125, 250 & 480 V AC; 0.25 AMPS @ 250 V DC; 0.5 AMPS @ 125 V DC (UL). |
| A2 | | | 5 AMPS @ 125 & 250 V AC (UL). |
| B6 | Precious metal alloy. | Precious metal alloy. | 20 AMPS @ 125, 250 & 480 V AC; 0.25 AMP @ 250 V DC; 0.5 AMP @ 125 V DC; 3/4 HP @ 125 V AC; 1 1/2 HP @ 250 V AC (UL). |
| F5 | Gold alloy. | Gold alloy. | Low level* to 1 AMP @ 125 V AC; 1 AMP @ 30 V DC (UL). |
| F9 | Fine silver. | Fine silver welded to copper base. | 22 AMPS @ 125 & 277 V AC; 15 AMPS @ 480 V AC; 1/4 HP @ 125 V AC; 1/2 HP @ 250 V AC; 277 V AC (UL). |

* Note: See Technical Data section of this catalog for RoHS compliant and compatible definition and specifications.

AVAILABLE COMBINATIONS

| ELECTRICAL RATING | OPERATING FORCE (oz.) | | | | | |
|-------------------|-----------------------|------|-------|-------|-------|-------|
| | 4 GF | 9 KA | 13 KC | 18 KG | 20 KH | 26 PB |
| A2 | • | • | • | • | • | • |
| B4 | x | • | • | • | • | • |
| B6 | x | x | x | • | • | • |
| F5 | x | x | • | • | • | • |
| F9 | x | x | x | • | • | • |

• AVAILABLE
x NOT AVAILABLE

All models with all options

Consult Customer Service center for availability and delivery of nonstandard ratings.

* Low Level=conditions where no arcing occurs during switching, i.e., 0.4 VA max. @ 20 V AC or DC max.

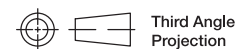

Dimensions are shown: Inch (mm)

Specifications and dimensions subject to change



HB Series Single Pole Standard Precision Snap-acting Switches

MOUNTING STYLE

S Standard

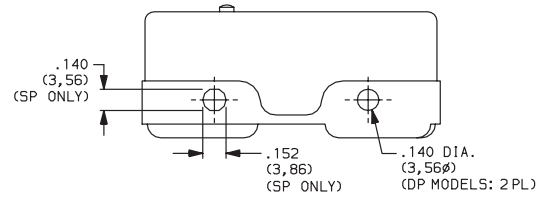

NOTE: Mounting holes will accept pins or screws of .139 dia. (3,53) max. on 1.000 ± .002 (25,4 ± 0,05) centers.

NOTE: Torque mounting screws 3 inlbs max.

ACTUATOR

| OPTION CODE | NO. POLES | FIG. | DIM. A | DIM. B | DIM. C | DIM. D |
|-------------|-----------|------|------------------|--------------------------------|----------------------|----------------|
| A0 | SP | 1 | .86 (21,8) | 1.120 ± .060 (28,45 ± 1,52) | .38 dia. (9,70) | 1.03 (26,2) |
| D0 | SP | 3 | .92 (23,4) | .844 ± .020 (21,44 ± 0,51) | — | — |
| F0 | SP | 2 | .09 (2,3) | 1.120 ± .050 (28,45 ± 1,27) | .38 dia. (9,70) | .74 (18,8) |
| J0 | SP | 4 | .86 (21,8) | .860 ± .030 (21,84 ± 0,76) | — | — |
| P0 | SP | 5 | .92 (23,4) | .625 ± .010 (15,88 ± 0,25) | — | — |
| R5 | SP | 6 | .92 (23,4) | .62 (15,7) | .50 dia. (12,70) | 0.61 (15,5) |
| T0 | SP | 7 | 1.310 (33,27) | .720 ± .060 (18,28 ± 1,52) | 1.03 dia. (26,20) | — |
| TS* | SP | 7 | 1.47 (37,3) | .720 ± .060 (18,28 ± 1,52) | 1.03 dia. (26,20) | — |
| Y0 | SP | 8 | .05 (1,3) | .720 ± .030 (18,29 ± 0,76) | .74 dia. (18,80) | 2.65 (6,73) |

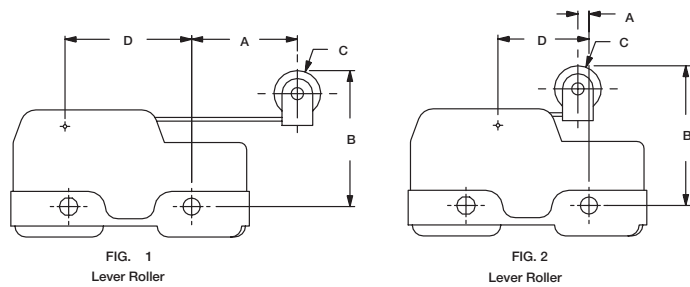

FIG. 1
Lever Roller

FIG. 2
Lever Roller

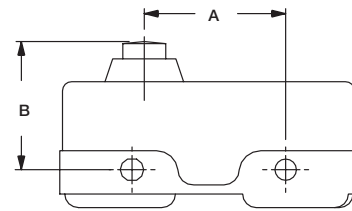

FIG. 3
Stub Plunger

Snap-acting

* Actuators sealed against the entrance of airborne contaminants and/or splashing liquids.

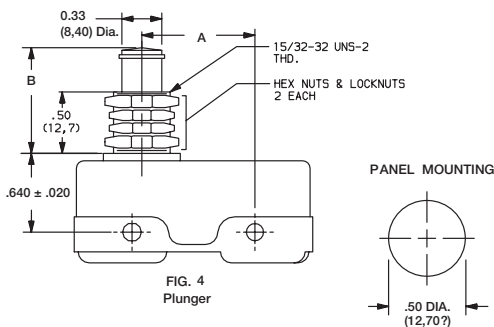

FIG. 4
Plunger

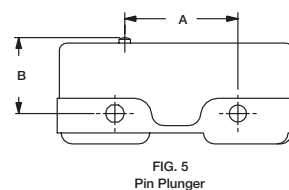

FIG. 5
Pin Plunger

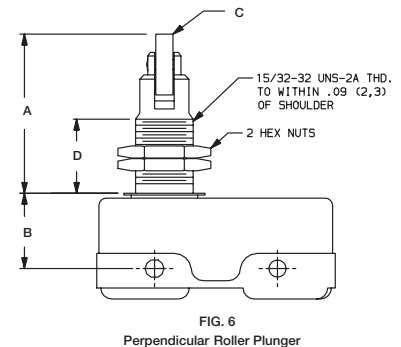

FIG. 6
Perpendicular Roller Plunger

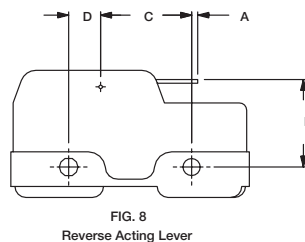

FIG. 8
Reverse Acting Lever

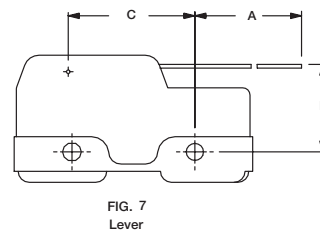
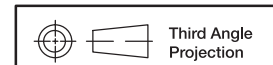

FIG. 7
Lever



Third Angle Projection

Dimensions are shown: Inches (mm)
Specifications and dimensions subject to change



HB Series Single Pole Standard Precision Snap-acting Switches

ACTUATOR

| | OPTION CODE | ACTUATOR | | | | | | | | * SEALED ACTUATOR |
|-------------------------------------|-------------|------------|------------|-----------|-----------|-----------|-----------|------------|-----------|-------------------|
| | | A0 | D0 | F0 | J0 | P0 | R5 | T0 | Y0 | TS |
| MAXIMUM OPERATING FORCE (OZ./GRAMS) | GF | — | — | — | — | 4 115 | — | — | — | — |
| | KA | 3 85 | 9.5 269 | 10 284 | 10 284 | 9 255 | 10 284 | 2 60 | 10 284 | 2 56 |
| | KC | — | 13 370 | 10 284 | 13 370 | 13 370 | 13 370 | — | 10 284 | — |
| | KG | 3.5 100 | — | — | — | 18 510 | — | 2.5 71 | — | 2.5 71 |
| | KH | 4 115 | 20 570 | 20 570 | 20 570 | 20 570 | 20 570 | 3 85 | 20 570 | 3 85 |
| | PB | 4.5 130 | 26 740 | 20 570 | 26 740 | 26 740 | 26 740 | 3.5 100 | 20 570 | 3.5 100 |
| MINIMUM RELEASE FORCE (OZ./GRAMS) | GF | — | — | — | — | 1 28 | — | — | — | — |
| | KA | .75 21 | 4 110 | 3 85 | 4 110 | 4 110 | 4 110 | .5 14 | 3 85 | .5 14 |
| | KC | 1.7 48 | 4 110 | 3 85 | 4 110 | 4 110 | 4 110 | — | 3 85 | — |
| | KG | .75 21 | — | — | — | 4 110 | — | .5 14 | — | .5 14 |
| | KH | .75 21 | 4 110 | 3 85 | 4 110 | 4 110 | 4 110 | .5 14 | 3 85 | .5 14 |
| | PB | .75 21 | 4 110 | 3 85 | 4 110 | 4 110 | 4 110 | .5 14 | 3 85 | .5 14 |

NOTE: For basic switch operating forces, see page J-71. * Actuators sealed against the entrance of airborne contaminants and/or splashing liquids.

| | OPTION CODE | ACTUATOR | | | | | | | | * SEALED ACTUATOR |
|-------------------------------------|-------------|----------------|------------------|----------------|----------------|------------------|----------------|----------------|----------------|-------------------|
| | | A0 | D0 | F0 | J0 | P0 | R5 | T0 | Y0 | TS |
| MAXIMUM DIFFERENTIAL TRAVEL (IN/MM) | GF | — | — | — | — | .0005 (0,013) | — | — | — | — |
| | KA | .020 (0,51) | .0005 (0,013) | .005 (0,13) | — | .0005 (0,013) | — | .047 (1,19) | .005 (0,13) | .047 (1,19) |
| | KC | — | .002 (0,05) | .008 (0,20) | — | .002 (0,05) | — | — | .009 (0,23) | — |
| | KG | .062 (1,57) | — | — | — | .003 (0,08) | — | .078 (1,98) | — | .078 (1,98) |
| | KH | .080 (2,03) | .003 (0,76) | .020 (0,51) | — | .003 (0,08) | — | .093 (2,36) | .020 (0,51) | .093 (2,36) |
| | PB | .125 (3,18) | .007 (0,18) | .030 (0,76) | — | .005 (0,13) | — | .156 (3,96) | .031 (0,79) | .156 (3,96) |
| MAXIMUM PRETRAVEL (IN/MM) | GF | — | — | — | — | .020 (0,51) | — | — | — | — |
| | KA | .312 (7,92) | .020 (0,51) | 0.8 (2,0) | .015 (0,38) | .015 (0,38) | .015 (0,38) | .38 (9,7) | .09 (2,3) | .38 (9,7) |
| | KC | — | .020 (0,51) | 0.8 (2,0) | .020 (0,51) | .020 (0,51) | .020 (0,51) | — | .09 (2,3) | — |
| | KG | .312 (7,92) | — | — | — | .025 (0,64) | — | .38 (9,7) | — | .38 (9,7) |
| | KH | .38 (9,7) | .025 (0,64) | 0.9 (2,3) | .025 (0,64) | .025 (0,64) | .025 (0,64) | .38 (9,7) | 0.9 (2,3) | .38 (9,7) |
| | PB | .38 (9,7) | .030 (0,76) | 0.9 (2,3) | .030 (0,76) | .030 (0,76) | .030 (0,76) | .38 (9,7) | 0.9 (2,3) | .38 (9,7) |
| MINIMUM OVERTRAVEL (IN/MM) | GF | — | — | — | — | .005 (0,13) | — | — | — | — |
| | KA | .156 (3,96) | .055 (1,40) | .06 (1,5) | .22 (5,6) | .005 (0,13) | .141 (3,58) | .19 (4,8) | .06 (1,5) | .19 (4,8) |
| | KC | — | .055 (1,40) | 0.9 (2,3) | .22 (5,6) | .005 (0,13) | .141 (3,58) | — | 0.9 (2,3) | — |
| | KG | .156 (3,96) | — | — | — | .005 (0,13) | — | .19 (4,8) | — | .19 (4,8) |
| | KH | .156 (3,96) | .055 (1,40) | 0.9 (2,3) | .22 (5,6) | .005 (0,13) | .141 (3,58) | .19 (4,8) | 0.9 (2,3) | .19 (4,8) |
| | PB | .156 (3,96) | .055 (1,40) | 0.9 (2,3) | .22 (5,6) | .005 (0,13) | .141 (3,58) | .19 (4,8) | 0.9 (2,3) | .19 (4,8) |



Dimensions are shown: Inch (mm)
Specifications and dimensions subject to change

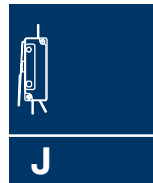

Snap-acting

HB Series Single Pole Standard Precision Snap-acting Switches

TERMINATIONS

11 FLAT BASE, SOLDER TERMINALS AND 4-40 SCREWS

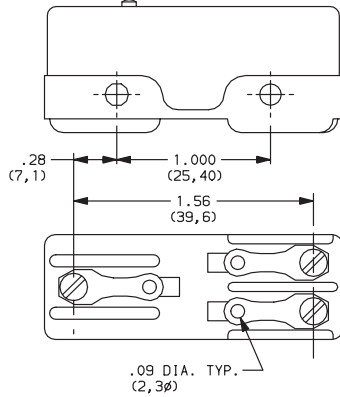

NOTE: Switches with flat base option have molded ribs that provide increased creep distance.

55 STEP BASE, 6-32 SCREWS AND CUP WASHERS

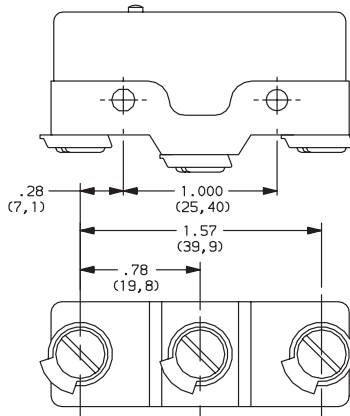

NOTE: Switches with step base option provide wide electrical clearance for screw terminal options.

41 FLAT BASE, .250" QUICK CONNECT TERMINALS

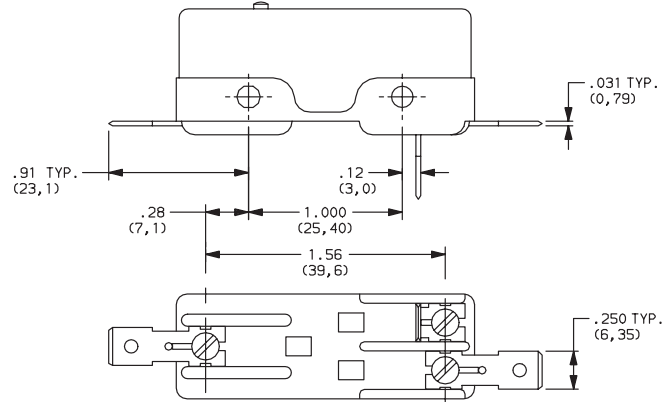

CIRCUITRY

C DT (Double Throw, Normally Closed & Normally Open)

Snap-acting



A Series General Purpose Snap-acting Switches

Features/Benefits

- Low cost—high performance
- Long electrical life
- Single and double pole
- Sealed actuator option available

Typical Applications

- Enclosure equipment
- Garage door openers
- Vending machines



Specifications

CONTACT RATING: From low level* to 30 AMPS @ 277 V AC.
 ELECTRICAL LIFE: 75,000 cycles at 25 AMPS @ 250 V AC,
 200,000 cycles at 15 AMPS @ 250 V AC.
 INSULATION RESISTANCE: 1,000 M ohm min.
 DIELECTRIC STRENGTH: 1,000 Vrms min. @ sea level.
 OPERATING TEMPERATURE: -67°F to 185°F (-55°C to 85°C).
 OPERATING FORCE: 20 oz. (567 grams) max. SP models.
 40 oz. (1134 grams) max. DP models at actuator button.
 MOUNTING: Torque screws 3 in/lbs max.
 MOUNTING NUT: 20 in/lbs max. torque

* Low Level=conditions where no arcing occurs during switching, i.e., 0.4 VA max. @ 20 V AC or DC max.

NOTE: Specifications and materials listed above are for switches with standard options. For information on specific and custom switches, consult Customer Service Center.

Materials

SWITCH HOUSING: Heat resistant phenolic (UL 94V-0).
 ACTUATOR BUTTON: Heat resistant phenolic (UL 94V-0).
 SPRING: Copper alloy.
 PIVOT: Brass alloy for models up to 15 AMPS.
 Copper for 25 AMP models.
 MOVABLE CONTACTS: Gold alloy for ratings 1 AMP or less.
 Fine silver for ratings up to 15 AMPS. Silver alloy for ratings of 30.1 AMPS.
 STATIONARY CONTACTS: Gold alloy on brass base alloy for ratings 1 AMP or less. Fine silver welded on brass base alloy for ratings greater than 1 AMP up to 15 AMPS. Fine silver welded on copper alloy for ratings 30.1 AMPS.
 TERMINALS: Brass alloy for 1 AMP up to 15 AMPS.
 Copper alloy for 30.1 AMPS.

Build-A-Switch

To order, simply select desired option from each category and place in the appropriate box. Available options are shown and described on pages J-78 through J-81. For additional options not shown in catalog, consult Customer Service Center.

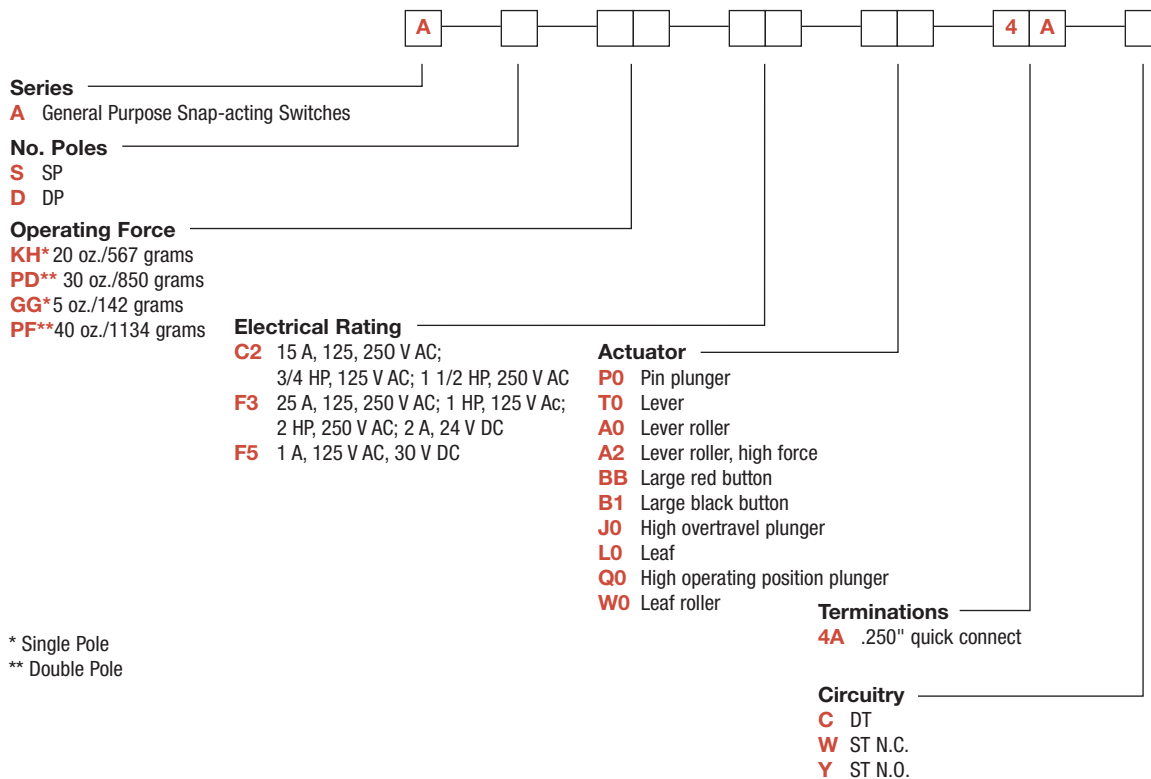

Snap-acting



Dimensions are shown: Inch (mm)
 Specifications and dimensions subject to change

A Series General Purpose Snap-acting Switches

SERIES ■ ■ ■ ■ ■ ■ ■ ■ ■ ■

A GENERAL PURPOSE SNAP-ACTING SWITCHES

NO. POLES ■ ■ ■ ■ ■ ■ ■ ■ ■ ■

S SINGLE POLE SWITCH

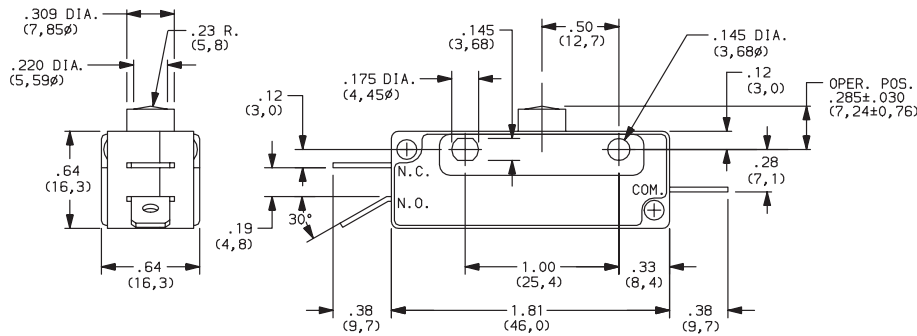
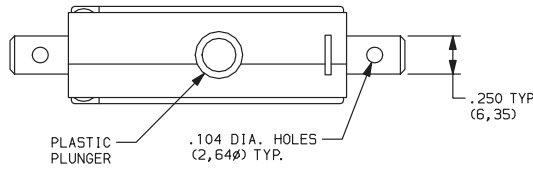

Mounting holes will accept pins or screws of .139 dia. (3,53) max., on 1.000 (25,40) centers.

D DOUBLE POLE SWITCH

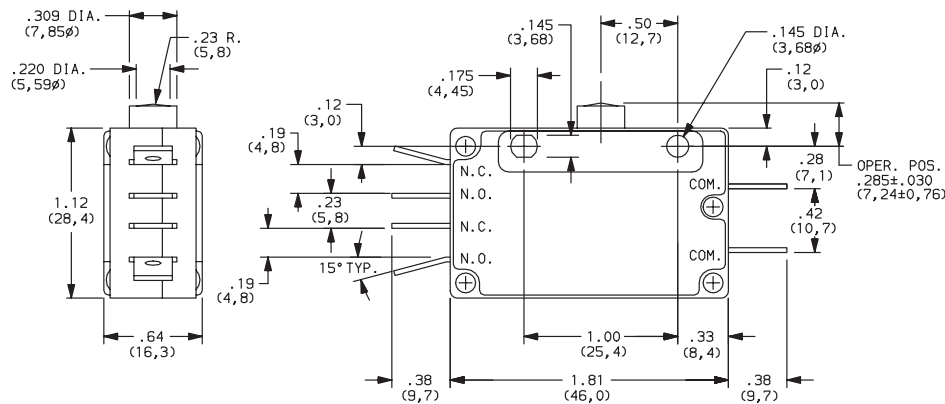
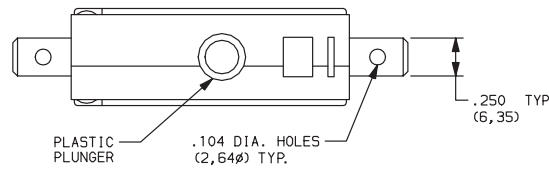

Mounting holes will accept pins or screws of .139 dia. (3,53) max., on 1.000 (25,40) centers.

NOTE: To select switching function, see CIRCUITRY section, page J-81.



Dimensions are shown: Inches (mm)
Specifications and dimensions subject to change



Snap-acting

A Series General Purpose Snap-acting Switches

OPERATING FORCE

| OPTION CODE | NO. POLES | BASIC SWITCH OPERATING FORCE (OZ./GRAMS) |
|-------------|-----------|--|
| KH | SP | 20 567 |
| PD | DP | 30 850 |
| GG | SP | 5 142 |
| PF | DP | 40 1134 |

NOTE: Operating force varies with actuator, see ACTUATOR option section.

ELECTRICAL RATING

| OPTION CODE | CONTACT MATERIAL | | ELECTRICAL RATING |
|-------------|------------------|---|---|
| | MOVABLE CONTACT | STATIONARY CONTACT | |
| C2 | Fine silver. | Fine silver welded on brass base alloy. | 15 AMPS @ 125 & 250 V AC; 3/4 HP @ 125 V AC; 1-1/2 HP @ 250 V AC. |
| F3 | Silver alloy. | Silver welded on copper base alloy. | 25 AMPS @ 125 & 250 V AC; 1 HP @ 125 V AC; 2 HP @ 250 V AC; 2 AMPS @ 24 V DC. |
| F5 | Gold alloy. | Gold alloy on brass base alloy. | From low level* to 1 AMP @ 125 V AC, 30 V DC. |

All models  with all options.

Contact Customer Service Center for availability and delivery of nonstandard ratings.

* Low Level=conditions where no arcing occurs during switching, i.e., 0.4 VA max. @ 20 V AC or DC max.

* Note: See Technical Data section of this catalog for RoHS compliant and compatible definition and specifications.

AVAILABLE COMBINATIONS

| ELECTRICAL RATING | OPERATING FORCE (OZ./GRAMS) | | | |
|-------------------|-----------------------------|-----------------|-----------------|------------------|
| | GG 5 142 | KH 20 567 | PD 30 850 | PF 40 1134 |
| C2 | • | • | • | • |
| F3 | X | • | • | • |
| F5 | • | • | • | • |

• AVAILABLE

X NOT AVAILABLE

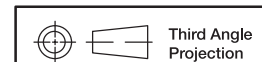

Dimensions are shown: Inch (mm)

Specifications and dimensions subject to change



A Series General Purpose Snap-acting Switches

ACTUATOR

| OPTION CODE | FIG. | DIM. A | DIM. B | DIM. C | DIM. D | DIM. E | DIM. F |
|-------------|------|----------------|-------------------------------|----------------------|--------------------|---------------|--------|
| P0 | 1 | .50 (12,7) | .285 ± .030 (7,24 ± 0,76) | — | — | — | — |
| A0 | 3 | 1.38 (35,1) | .718 ± .062 (18,24 ± 1,57) | .375 dia. (9,530) | .50 (12,7) | .50 (12,7) | — |
| A2 | 4 | 1.25 (31,8) | .718 ± .062 (18,24 ± 1,57) | .375 dia. (9,530) | .50 (12,7) | — | — |
| B1 | 6 | 1.50 (38,1) | .40 ± 0.1 (10,2 ± 2,54) | .98 dia. (24,90) | — | — | — |
| BB | 6 | 1.50 (38,1) | .40 ± 0.1 (10,2 ± 2,54) | .98 dia. (24,90) | — | — | — |
| J0 | 5 | .50 (12,7) | .810 ± .030 (20,6 ± 0,8) | .38 (9,7) | .25 dia. (6,40) | — | — |
| L0 | 2 | 1.62 (41,1) | .312 ± .062 (17,92 ± 1,57) | .50 (12,7) | — | — | — |
| Q0 | 5 | .50 (12,7) | .670 ± .030 (17,02 ± 0,76) | .38 (9,6) | .25 dia. (6,40) | — | — |
| T0 | 7 | 1.50 (38,1) | .318 ± .062 (8,08 ± 1,57) | .50 (12,7) | .50 (12,7) | — | — |
| W0 | 8 | 1.50 (38,1) | .801 ± .062 (20,34 ± 1,57) | .375 dia. (9,530) | .50 (12,7) | — | — |

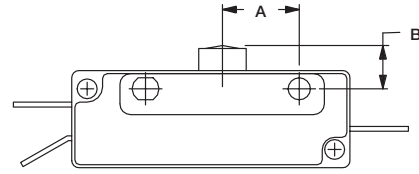

FIG. 1
High Overtravel Plunger

NOTE: The "H0" high overtravel plunger option provides .100 (2,54) min. overtravel and longer mechanical life (1,000,000 operations typical).

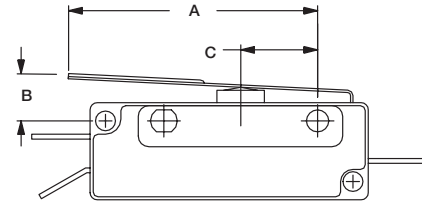

FIG. 2
Leaf

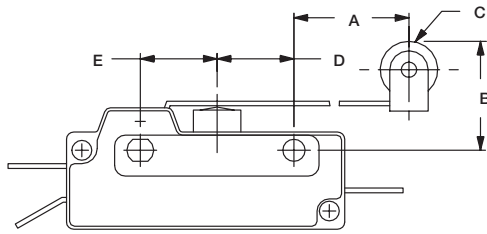

FIG. 3
Lever Roller

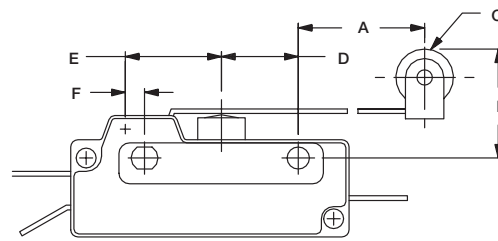

FIG. 4
Lever roller (High Force)

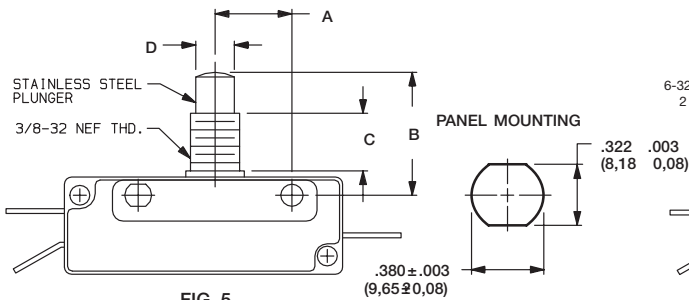

FIG. 5
High Overtravel Plunger

Torque 20 in/lbs max. (Nut)

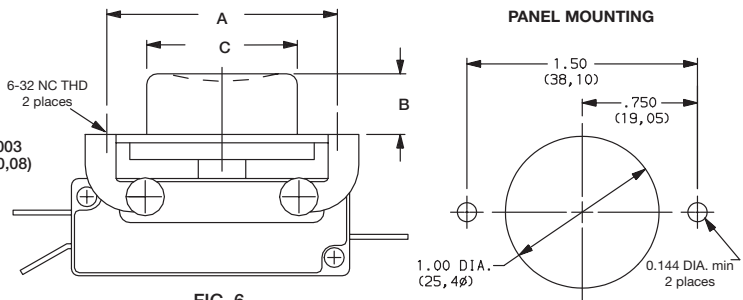

FIG. 6
B1 - Black Button
BB - Red Button

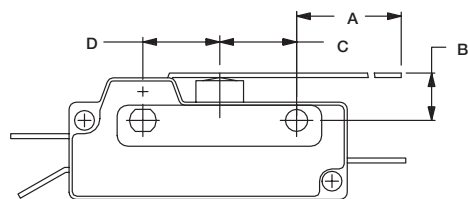

FIG. 7
Lever

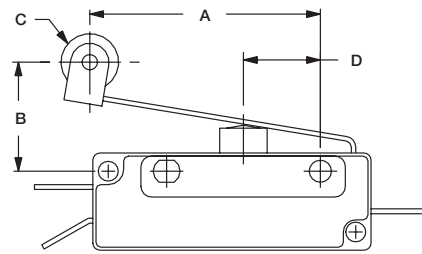
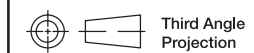

FIG. 8
Leaf Roller

Snap-acting



Dimensions are shown in inches (mm)

Specifications and dimensions subject to change



A Series General Purpose Snap-acting Switches

ACTUATOR

SWITCH CHARACTERISTICS

| OPTION CODE | MAXIMUM OPERATING FORCE (OZ./GRAMS) | | | | MINIMUM RELEASE FORCE (OZ./GRAMS) | | | | MAXIMUM PRETRAVEL | | | | MINIMUM OVERTRAVEL | | | | OPERATING POSITION | | | |
|-------------|-------------------------------------|-----------|-----------|------------|-----------------------------------|-----------|-----------|---------|-------------------|---------|---------|---------|--------------------|----------------|---------|---------|--------------------|---------|---------|---------|
| | GG S.P. | KH S.P. | PD D.P. | PF D.P. | GG S.P. | KH S.P. | PD D.P. | PF D.P. | GG S.P. | KH S.P. | PD D.P. | PF D.P. | GG S.P. | KH S.P. | PD D.P. | PF D.P. | GG S.P. | KH S.P. | PD D.P. | PF D.P. |
| A0 | 1.5 42.5 | 4 113 | 6 170 | 10 283 | 0.3 8.5 | 0.5 14 | 1 28 | | .312 (7,92) | | | | 312 (7,92) | .187 (4,75) | | | .718 (18,24) | | | |
| A2 | 1.5 42.5 | 4 113 | 6 170 | 10 283 | 0.4 11 | 0.5 14 | 1 28 | | .25 (6,4) | | | | .14 (5,6) | | | | .718 (18,24) | | | |
| B1 | 8 227 | 20 567 | 30 850 | 40 1134 | 1 28 | 3 85 | 6 170 | | .050 (1,27) | | | | .050 (1,27) | | | | — | | | |
| BB | 8 227 | 20 567 | 30 850 | 40 1134 | 1 28 | 3 85 | 6 170 | | .050 (1,27) | | | | .050 (1,27) | | | | — | | | |
| J0 | 5 142 | 20 567 | 30 850 | 40 1134 | 1 28 | 3 85 | 6 170 | | .050 (1,27) | | | | .187 (4,75) | | | | — | | | |
| L0 | 3 85 | 12 340 | 18 510 | 22 624 | 0.5 14 | 1 28 | 2 56.7 | | .281 (7,14) | | | | .062 (1,57) | | | | .312 (7,92) | | | |
| P0 | 8 227 | 20 567 | 30 850 | 40 1134 | 1 28 | 3 85 | 6 170 | | .050 (1,27) | | | | .050 (1,27) | | | | — | | | |
| Q0 | 5 142 | 20 567 | 30 850 | 40 1134 | 1 28 | 3 85 | 6 170 | | .050 (1,27) | | | | .050 (1,27) | | | | — | | | |
| T0 | 1.5 42.5 | 4 113 | 6 170 | 10 283 | 0.3 8.5 | 0.5 14 | 1 28 | | .312 (7,92) | | | | .187 (4,75) | | | | 312 (7,92) | | | |
| W0 | 3 85 | 12 340 | 18 510 | 22 624 | 0.5 14 | 1 28 | 2 56.7 | | .281 (7,14) | | | | .062 (1,57) | | | | .718 (18,24) | | | |

NOTE: For basic switch operating forces, see page J-77.

TERMINATIONS

4A .250" QUICK CONNECT

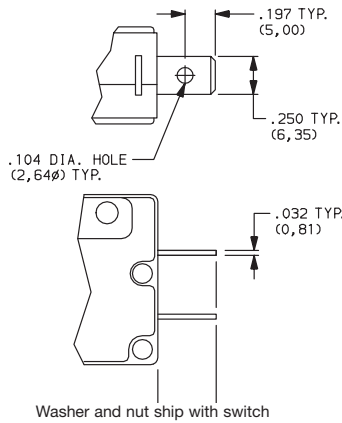

NOTE: Terminals can be supplied at various angles. Other terminal styles can be supplied for special applications. Consult Customer Service Center for special requirements.

CIRCUITRY

- C** DT (Double Throw, Normally Open & Normally Closed)
- W** ST N.C. (Single Throw, Normally Closed)
- Y** ST N.O. (Single Throw, Normally Open)

NOTE: To select number of poles, see NO. POLES section, page J-56



Dimensions are shown: Inches (mm)
Specifications and dimensions subject to change

C&K



Snap-acting

TL Series Door Interlock Switches

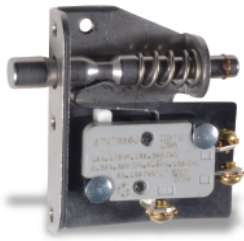

Features/Benefits

- Push/pull motion
- Multiple mounting configurations
- Wide variety of termination options
- Ratings up to 15 AMPS

Typical Applications

- Computer enclosures
- Panel builders
- Industrial enclosures

Specifications

CONTACT RATING: 15 AMPS @ 125 & 250 V AC; 0.25 AMP @ 250 V DC; 0.5 AMP @ 125 V DC; 1/2 HP @ 125 & 250 V AC; 3 AMPS @ 125 V AC "L".

ELECTRICAL LIFE: 150,000 cycles at 15 AMPS @ 250 V AC.

INSULATION RESISTANCE: 1,000 M ohm min.

DIELECTRIC STRENGTH: 1,000 Vrms min. @ sea level.

OPERATING TEMPERATURE: -67°F to 302°F (-55°C to 150°C).

NOTE: Specifications and materials listed above are for switches with standard options. For information on specific and custom switches, consult Customer Service Center.

Materials

SWITCH HOUSING: Thermoplastic or general purpose phenolic (UL 94V-0).

MOUNTING BRACKET: Stainless steel.

PLUNGER: Stainless steel.

ACTUATOR BUTTON: Thermoplastic (UL 94V-0).

SPRING: Copper alloy.

PIVOT: Brass alloy.

MOVABLE CONTACT: Fine silver.

STATIONARY CONTACTS: Fine silver.

TERMINALS: Copper alloy.



Snap-acting

Build-A-Switch

To order, simply select desired option from each category and place in the appropriate box. Available options are shown and described on pages J-83 and J-84. For additional options not shown in catalog, consult Customer Service Center.

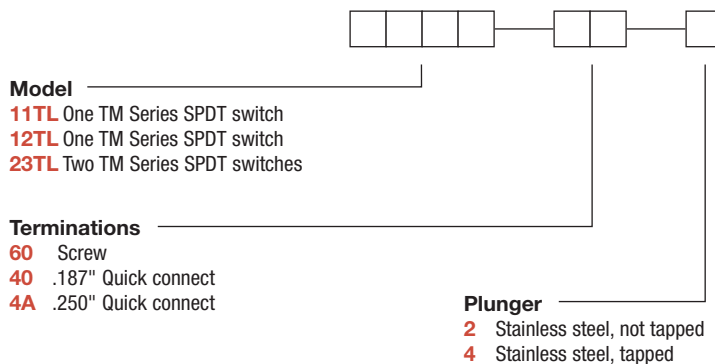

TL Series Door Interlock Switches

MODEL

23TL WITH TWO SWITCHES

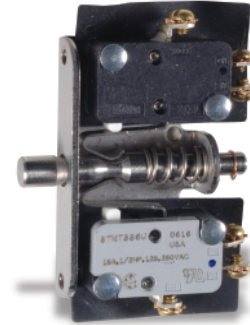
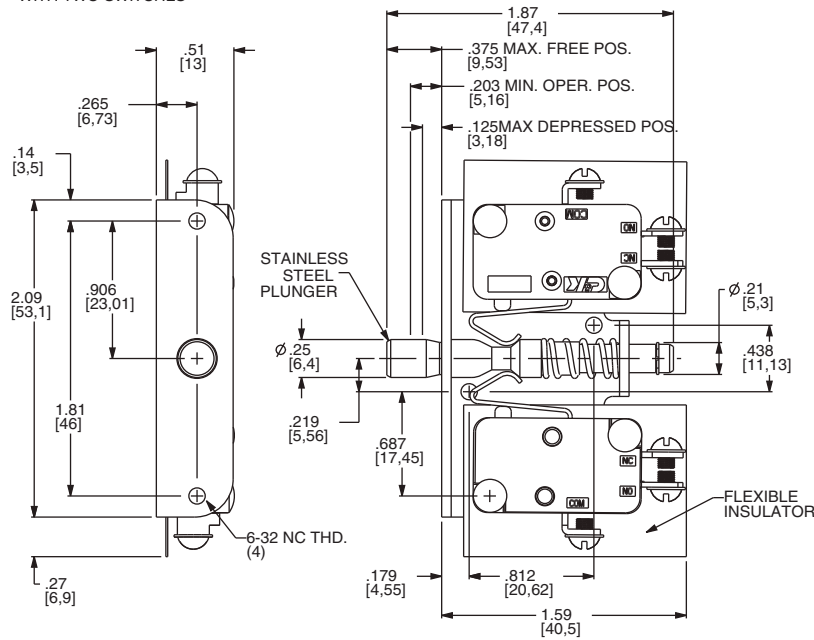

**23TL602
SPDT**

TERMINATIONS

60 SCREW TERMINALS

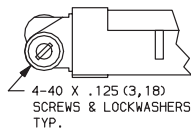

Torque screws to 6in lbs max

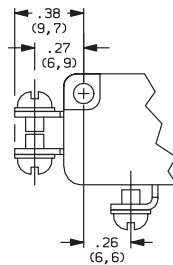

40 .187" QUICK CONNECT

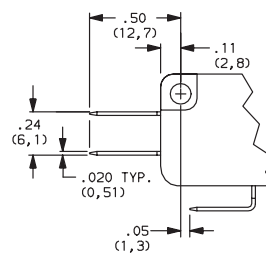
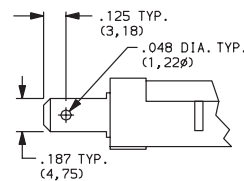

4A .250" QUICK CONNECT

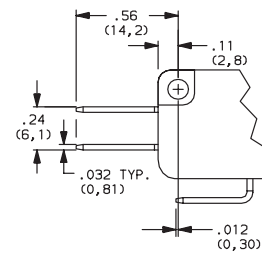
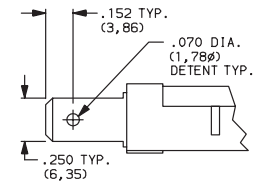

PLUNGERS

2 STAINLESS STEEL, NOT TAPPED

4 STAINLESS STEEL, TAPPED 4-40 x .375 (9,52) min. depth

Snap-acting



Third Angle Projection

Dimensions are shown: Inches (mm)
Specifications and dimensions subject to change



DS Series Interlock Pushbutton Switches

Features/Benefits

- Snap-in mounting
- Reliable snap action mechanism
- Latch or momentary
- RoHS compliant
- Halogen free material

Typical Applications

- Interlock switch
- Detection switch
- Circuit interrupt



Specifications

FUNCTION: Single pole double throw / Double pole double throw
MOUNTING TYPE: Snap in style

Electrical

ELECTRICAL LIFE: see ratings chart below
DIELECTRIC STRENGTH: 1500 V (50-60 Hz @ sea level)
INSULATION RESISTANCE: 100 M Ω min.
INITIAL CONTACT RESISTANCE: 30 milli-ohms

Materials

HOUSING, COVER, ACTUATOR, KNOB: PA 66/6 halogen free, UL94V-0
NO & NC FIXED TERMINALS: Copper alloy
COMMON TERMINALS: Copper alloy, silver plate
CONTACTS: Silver alloy / F5 rating gold plated over silver alloy
RETURN SPRINGS: Stainless steel

Operating Environment

OPERATING TEMPERATURE: -40°C to +85°C

NOTE: Specifications and materials listed above are for switches with standard options. For information on specific and custom switches, please contact Customer Service.



Snap-acting

Build-A-Switch

To order, simply select desired option from each category and place in the appropriate box.

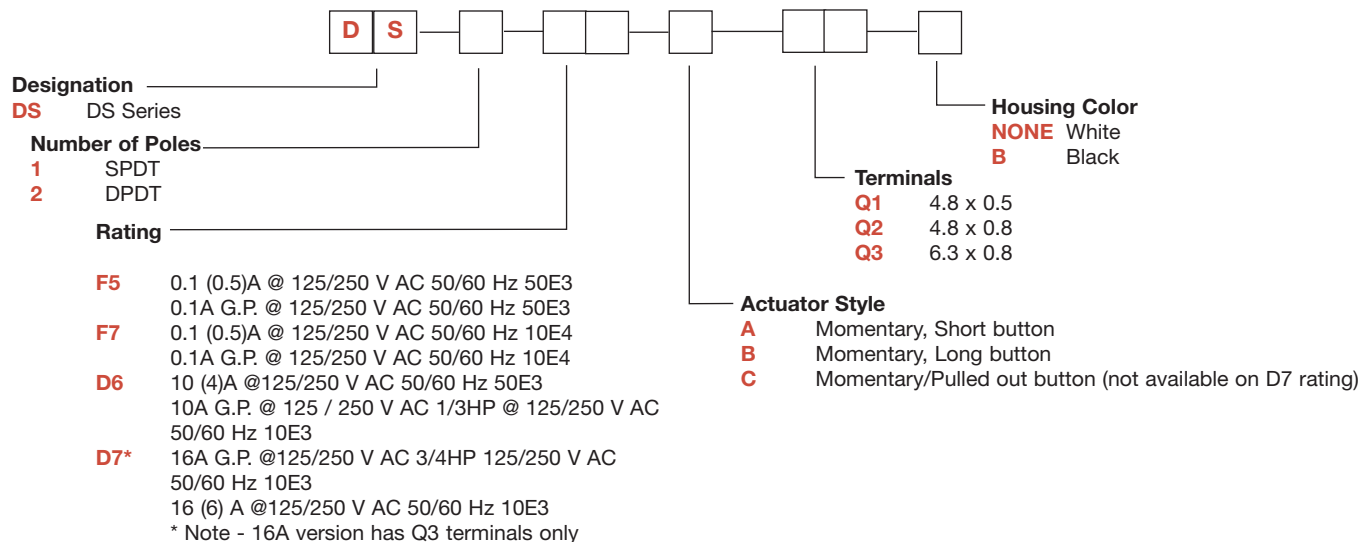

International Rating Symbols

| | |
|-------|---|
| 10E3 | Cycles 10,000 |
| 10E4 | Cycles 100,000 |
| 50E3 | Cycles 50,000 |
| 10(4) | Current rating: First number represents resistive rating. Second number represents inductive (motor) rating |
| GP | General purpose rating UL1054 |



DS Series Interlock Pushbutton Switches

NUMBER OF POLES

1 SPDT

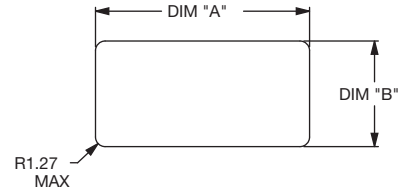
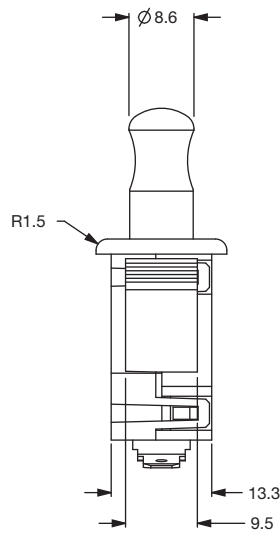
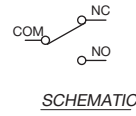
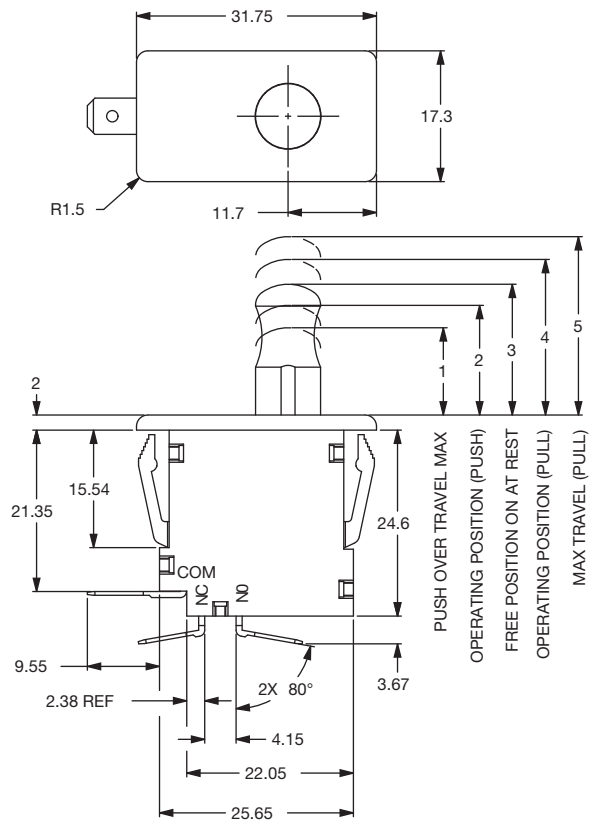

| PANEL MOUNTING | | |
|-----------------|------------|------------|
| PANEL THICKNESS | DIM "A" mm | DIM "B" mm |
| 1.14 | 28.32 | 13.97 |
| 2.54 | 28.58 | 13.97 |

Snap-acting

2 DPDT

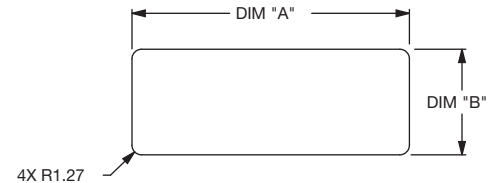
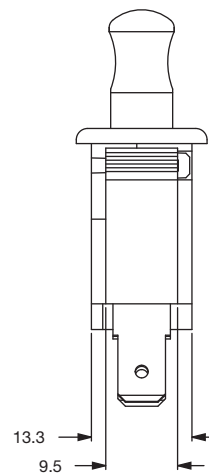
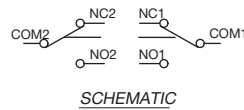
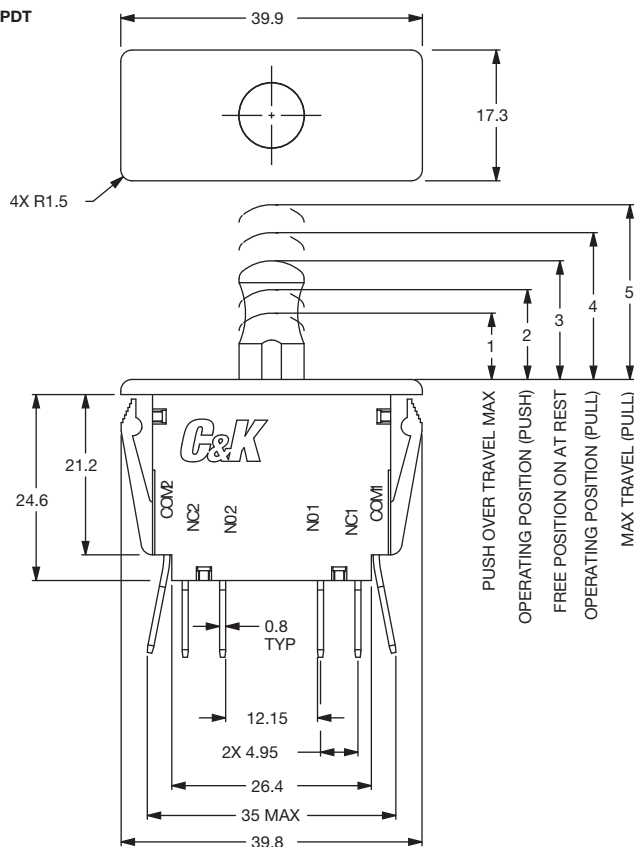

| PANEL MOUNTING | | |
|-----------------|------------|------------|
| PANEL THICKNESS | DIM "A" mm | DIM "B" mm |
| 1.14 | 36.70 | 13.97 |
| 2.54 | 36.96 | 13.97 |



31 oct 16

J-86



Dimensions are shown: mm
Specifications and dimensions subject to change

www.ck-components.com

DS Series Interlock Pushbutton Switches

ACTUATOR STYLE / SPECIFICATIONS

A SHORT BUTTON

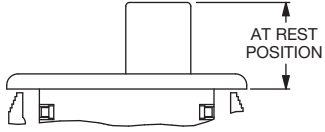

SHORT BUTTON

B LONG BUTTON

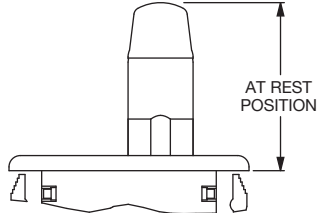

LONG BUTTON

C MOMENTARY/PULLED OUT

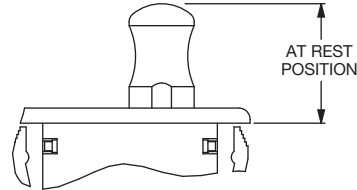

FREE POSITION

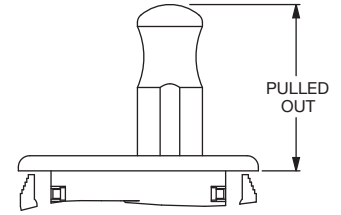

PULLED OUT POSITION

SPDT Specification

| BUTTON STYLE | OVER TRAVEL POSITION PUSH MAX | OVER TRAVEL POSITION PULL MAX | OPERATING POSITION PUSH | OPERATING POSITION PULL | FREE POSITION AT REST | OPERATING FORCE | |
|--------------|-------------------------------|-------------------------------|-------------------------|-------------------------|-----------------------|-----------------|---------------|
| A | 3.20 | NA | 8.90 ± 1.25 | NA | 11.45 ± 0.75 | 425 gf | |
| B | 10.15 | NA | 19.55 ± 1.25 | NA | 22.25 ± 0.75 | 425 gf | |
| C | 13.20 | 24.90 | 16.75 ± 1.25 | 21.60 ± 1.25 | 19.30 ± 0.75 | PUSH 385gf | PULL 475gf |

DPDT Specification

| BUTTON STYLE | OVER TRAVEL POSITION PUSH MAX | OVER TRAVEL POSITION PULL MAX | OPERATING POSITION PUSH | OPERATING POSITION PULL | FREE POSITION AT REST | OPERATING FORCE | |
|--------------|-------------------------------|-------------------------------|-------------------------|-------------------------|-----------------------|-----------------|---------------|
| A | 3.20 | NA | 8.90 ± 1.25 | NA | 11.45 ± 0.75 | 680 gf | |
| B | 10.15 | NA | 19.55 ± 1.25 | NA | 22.25 ± 0.75 | 680gf | |
| C | 13.20 | 24.90 | 16.75 ± 1.25 | 21.60 ± 1.25 | 19.30 ± 0.75 | PUSH 560gf | PULL 750gf |

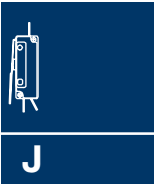

Snap-acting

TERMINALS

Q1 4.8 x 0.5
Q2 4.8 x 0.8

Q3 6.3 x 0.8

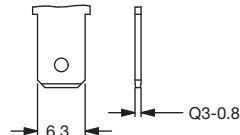
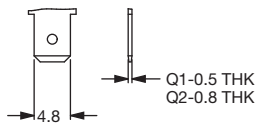

31 oct 16









Third Angle Projection

Dimensions are shown: mm
Specifications and dimensions subject to change

Rotary Switches

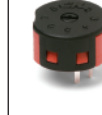
Product Selection Guide

| Rotary |  |  |  |  |  |  |  |
|---------------------------------------|---|---|---|---|---|--|---|
| Series | A | RTA | M | R | F | H | RW |
| Switch Type | Multi-pole/ Multi-position | Multi-pole/ Multi-position | Half-inch | Rota-slide | Rota-slide | Power Rota-slide | Subminiature Rotary SMT |
| Miniature | | • | | | • | | • |
| Low Profile | | | | | • | | • |
| Screwdriver Slot | • | • | • | • | • | | |
| Illumination | | | | | | | |
| Power | | | | | | • | |
| Maximum Current | 2.5 Amps | 150 mA | 6 Amps | 5 Amps | 4 Amps | 12 Amps | 0.1 A 10mA |
| Poles | 1-4 | 1-4 | 1 & 2 | 1 & 2 | 1 & 2 | 1 & 2 | 1 |
| Indexing | 30°, 45°, 90° | 22.5°, 30° 36° | 30° & 36° | 36° | 45° & 90° | 45° & 90° | 36° & 45° |
| Splashproof | • | | • | | | | |
| Sealed | | | • F option | | | | |
| Non-shorting/ Shorting Contacts | • | | | | | | |
| Panel Mount Options | | | | | | | |
| Front Mount | | | | | | | |
| Rear Mount | • | • | • | • | • | • | |
| PCB Mount Options | | | | | | | |
| Vertical | • | • | • | • | • | | • |
| Terminations | | | | | | | |
| Solder Lug | • | • | • | • | • | • | |
| Wire Lead | | | | • | • | • | |
| Quick Connect | | | | | | • | |
| PC | • | • | • | • | • | | • |
| Page No. | K-3 | K-8 | K-13 | K-18 | K-21 | K-25 | K-28 |

A Series 1-4 Pole Rotary Switches

Features/Benefits

- Multi-pole and multi-position
- Positive detent
- Shorting & non-shorting contacts
- Panel and PCB mounting
- RoHS Compliant



Models Available

Typical Applications

- Automotive
- Major and small appliances
- Industrial equipment



Specifications

CONTACT RATING: Q contact material: Switch - 2.5 AMPS @ 125 V AC; 350 mA @ 125 V DC (UL/CSA). Carry - 5 AMPS continuous. See page K-6 for additional ratings.

ELECTRICAL LIFE: 15,000 make-and-break cycles at full load up to 300,000 detent operations.

CONTACT RESISTANCE: Below 20 m Ω typ. initial @ 2-4 V DC, 100 mA, for both silver and gold plated contacts.

INSULATION RESISTANCE: 10⁹ Ω min.

DIELECTRIC STRENGTH: 1,000 Vrms min. @ sea level.
Operating and storage temp: -30° to 85°C

OPERATING & STORAGE TEMPERATURE: -30°C to 85°C

NOTE: Any models supplied with Q, B or G contact material are RoHS compliant.

NOTE: Specifications and materials listed above are for switches with standard options. For information on specific and custom switches, consult Customer Service Center.

Materials

HOUSING & BUSHING: Glass filled 6/6 nylon (UL 94V-0).

ACTUATOR: Glass filled 6/6 nylon (UL 94V-0).

MOVABLE CONTACTS: Q contact material: Coin silver, silver plated. See page K-6 for additional contact materials.

STATIONARY CONTACTS & TERMINALS: Q contact material: Brass, silver plated. See page K-6 for additional contact materials.

HARDWARE: Nut - zinc, nickel plated. Lockwasher — steel, bright zinc plated. Stop Ring - brass, nickel plated.

TERMINAL SEAL: Epoxy.

Build-A-Switch

To order, simply select desired option from each category and place in the appropriate box. Available options are shown and described on pages K-4 through K-7. For additional options not shown in catalog, consult Customer Service Center.

| | | | | | | | |
|---|---|---|---|--|---|--|--|
| | | | | | | | |
| Switch Function | Actuator | Mounting Style | Shorting/ Non-shorting Contacts | Terminations | Contact Material | Seal | |
| A100 SP, 30° Index, 12 pos. no stops A102 SPDT, 30° Index A103 SP, 30° Index, 3 pos. A104 SP, 30° Index, 4 pos. A105 SP, 30° Index, 5 pos. A106 SP, 30° Index, 6 pos. A107 SP, 30° Index, 7 pos. A108 SP, 30° Index, 8 pos. A109 SP, 30° Index, 9 pos. A110 SP, 30° Index, 10 pos. A112 SP, 30° Index, 12 pos. A114 SP, 90° Index, 2 pos. A115 SP, 45° Index, 3 pos. A124 SP, 90° Index, 4 pos. A125 SP, 45° Index, 8 pos. A203 DP, 30° Index, 3 pos. A204 DP, 30° Index, 4 pos. A205 DP, 30° Index, 5 pos. A206 DP, 30° Index, 6 pos. A214 DP, 90° Index, 2 pos. A303 3P, 30° Index, 3 pos. A304 3P, 30° Index, 4 pos. A402 4PDT, 30° Index A403 4P, 30° Index, 3 pos | 15 1.500" high, flatted 03 .375" high, flatted 05 .500" high, flatted 14 1.500" high, flatted 42 1.654" high, metric S1 Screwdriver Slot | R 3/8-32 threaded M M10 x .75 metric | N Non-shorting contacts S Shorting contacts (Not available with models A114, A124 & A214) | Z Solder lug C PC Thru-hole MC Modular base | Q Silver B Gold G Gold over silver | NONE No seal E Epoxy seal F Splashproof bushing seal K Epoxy & splashproof bushing seal | |

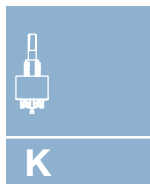

Rotary



Dimensions are shown: Inch (mm)
Specifications and dimensions subject to change

A Series 1-4 Pole Rotary Switches

SWITCH FUNCTION

| 30° INDEXING | | | |
|--------------|-------------|----------------------|--------------------|
| NO. POLES | MODEL NO. | SWITCH FUNCTION | TERMINALS |
| SP | A100 | 12 Position No Stops | A,1-12 |
| | A102 | SPDT | A,1,2* |
| | A103 | 3 Position | A,1-3* |
| | A104 | 4 Position | A,1-4* |
| | A105 | 5 Position | A,1-5* |
| | A106 | 6 Position | A,1-6* |
| | A107 | 7 Position | A,1-7 |
| | A108 | 8 Position | A,1-8 |
| | A109 | 9 Position | A,1-9 |
| | A110 | 10 Position | A,1-10 |
| A112 | 12 Position | A,1-12 | |
| DP | A203 | 3 Position | A,C,1-3,7-9 |
| | A204 | 4 Position | A,C,1-4,7-10 |
| | A205 | 5 Position | A,C,1-5,7-11 |
| | A206 | 6 Position | A,C,1-12 |
| 3P | A303 | 3 Position | A,B,C,1-3,5-7,9-11 |
| | A304 | 4 Position | A,B,C,1-12 |

SP MODELS SCHEMATIC

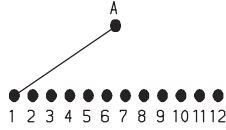

DP MODELS SCHEMATIC

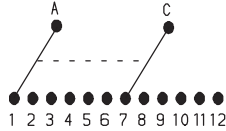

3P MODELS SCHEMATIC

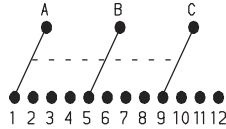

4P MODELS SCHEMATIC

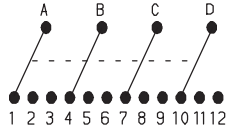

| 30° INDEXING | | | |
|--------------|-----------|-----------------|---------------------------|
| NO. POLES | MODEL NO. | SWITCH FUNCTION | TERMINALS |
| 4P | A402 | 4PDT | A,B,C,D,1,2,4,5,7,8,10,11 |
| | A403 | 3 Position | All Terminals |

| 45° INDEXING | | | |
|--------------|-----------|-----------------|---------------------|
| NO. POLES | MODEL NO. | SWITCH FUNCTION | TERMINALS |
| SP | A115 | 3 Position | A,1,2,4* |
| | A125 | 8 Position | A,1,2,4,5,7,8,10,11 |

| 90° INDEXING | | | |
|--------------|-----------|-----------------|--------------|
| NO. POLES | MODEL NO. | SWITCH FUNCTION | TERMINALS |
| SP | A114 | 2 Position | A,1,4* |
| | A124 | 4 Position | A,1,4,7,10 |
| DP | A214 | 2 Position | A,C,1,4,7,10 |

TERMINAL NUMBERS

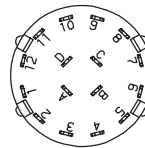

Terminal numbers molded on bottom of housing.

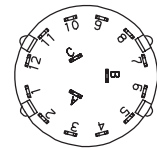

3P MODELS

4P MODELS
SP MODELS (omit terminals B, C & D)
DP MODELS (omit terminals B & D)

NOTE: * These models with 'C' or 'MC' terminations have additional terminal no. 9 as switch support only. This terminal is not connected electrically inside switch.

All models **C&K** with all options when ordered with 'G' or 'Q' contact material, see page K-6.

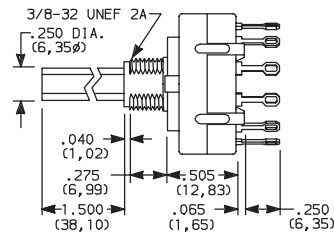
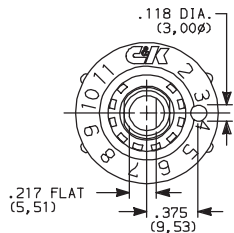

TERM. NOS.
MOLDED ON HOUSING

Rotary
K



Dimensions are shown: Inch (mm)
Specifications and dimensions subject to change

A Series 1-4 Pole Rotary Switches

ACTUATOR

- 15** 1.500" HIGH **03** .375" HIGH **05** .500" HIGH **14** 1.500" HIGH **42** 1.654" METRIC **S1** SCREWDRIVER SLOT

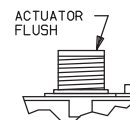
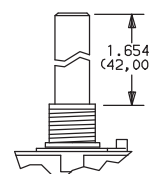
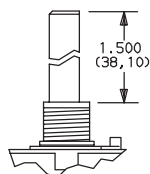
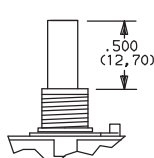
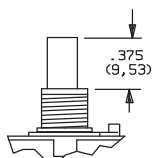
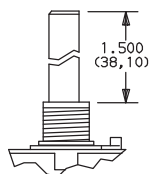
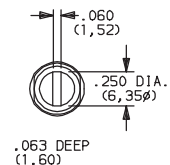
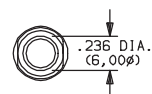
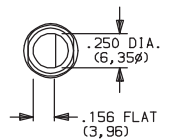
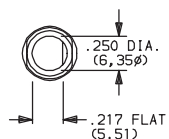
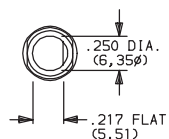
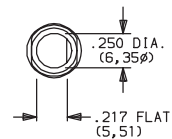

NOTE: Actuators shown in position 1, fully CCW.

MOUNTING STYLE

- R** 3/8-32 THREAD

- M** M10 x .75 METRIC

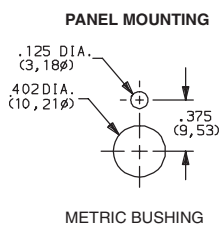
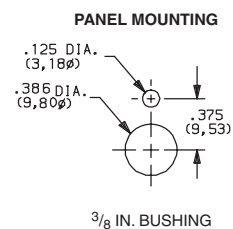
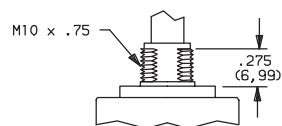
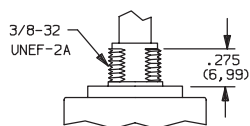

TYPICAL INSTALLATION

Maximum force to push on knob should not exceed 10 lbs.

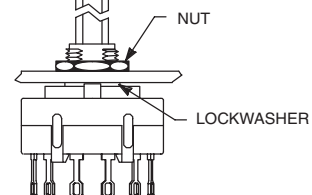

Install switch with stop ring (if used) and lockwasher in back of panel. Tighten hex nut from front of panel.

On PC mounted switches, use hex nut and lockwasher to hold stop ring in place.

Actuation torque: 8-16 oz./in.
Maximum torque: 30 oz./in.

SHORTING/NON-SHORTING CONTACTS

- N** NON-SHORTING CONTACTS (break-before-make)
S SHORTING CONTACTS (make-before-break)

NOTE: 'S' shorting contacts are not available with A114, A124 and A214 models.



Third Angle
Projection

Dimensions are shown: Inch (mm)
Specifications and dimensions subject to change

A Series 1-4 Pole Rotary Switches

TERMINATIONS

Z SOLDER LUG

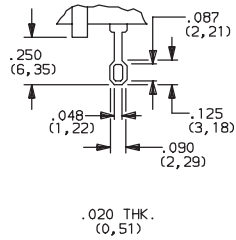

C PC THRU-HOLE

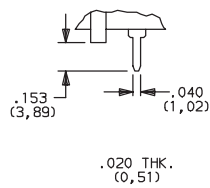

MC MODULAR BASE (for wave soldering)

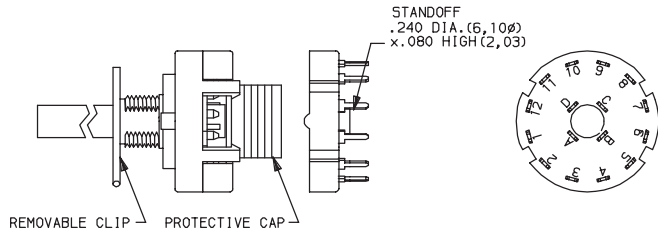

NOTE: Switches with 'C' or 'MC' terminations have additional terminal no. 9 as switch support only. This terminal is not connected electrically inside switch. Solder and clean switch base on PC board with other components, then snap on housing/actuator assembly. See page K-7 for installation instructions.

PC MOUNTING

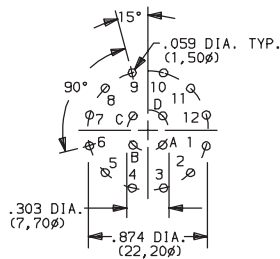

4P MODEL
SP MODEL (omit terminals B, C & D)
DP MODEL (omit terminals B & D)

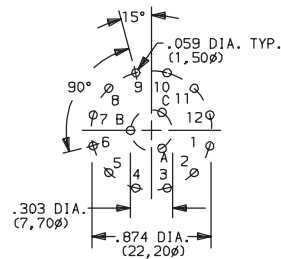

3P MODEL

CONTACT MATERIAL

| OPTION CODE | CONTACT AND TERMINAL MATERIAL | RATING | |
|-------------|-------------------------------|-----------------------------------|---|
| Q | SILVER ² | POWER | SWITCH-2.5 AMPS @ 125 V AC; 350 mA @ 125V DC (UL/CSA). CARRY-5 AMPS CONTINUOUS. |
| B | GOLD ¹ | LOW LEVEL/DRY CIRCUIT | 0.4 VA MAX. @ 20 V AC or DC MAX |
| G | GOLD OVER SILVER ³ | LOW LEVEL/DRY CIRCUIT OR POWER | 0.4 VA MAX. @ 20 V AC or DC MAX. or SWITCH-2.5 AMPS @ 125 V AC; 350 mA @ 125 V DC (UL/CSA). CARRY-5 AMPS CONTINUOUS. |

* Note: See Technical Data section of this catalog for RoHS compliant and compatible definition and specifications.

¹ MOVABLE CONTACTS: Copper alloy, with gold plate over nickel plate.
STATIONARY CONTACTS & TERMINALS: Brass, with gold plate over nickel plate.

² MOVABLE CONTACTS: Coin silver, silver plated.
STATIONARY CONTACTS & TERMINALS: Brass, silver plated (standard with all termination options).

³ MOVABLE CONTACTS: Coin silver, with gold plate over nickel plate over silver plate.
STATIONARY CONTACTS & TERMINALS: Brass, with gold plate over nickel plate over silver plate.

NOTE: Any models supplied with Q, B or G contact material are RoHS compliant.

All models  with all options when ordered with 'G' or 'Q' contact material.

NOTE: 'G' contact material is equivalent to both 'B' and 'Q' contact materials.

Rotary



K

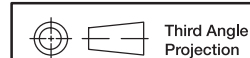

Dimensions are shown: Inch (mm)
Specifications and dimensions subject to change

A Series 1-4 Pole Rotary Switches

FUNCTION

NONE NO SEAL

E EPOXY SEAL

F SPLASHPROOF BUSHING SEAL

K EPOXY & SPLASHPROOF BUSHING SEAL

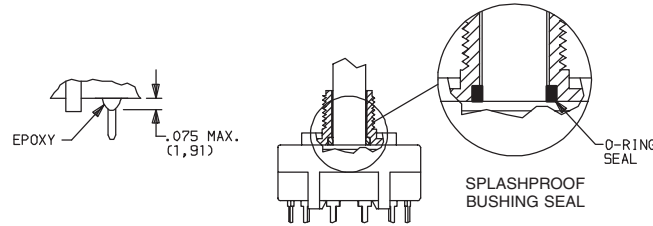

Setting Stops on A112 and A125 Models

The number of switch positions is adjustable on A112 and A125 models only by means of a stop ring provided with each switch. The number of positions is pre-set on all other models and the stop ring is factory installed.

To set stops: Turn shaft fully counter-clockwise and insert stop ring tab in desired hole. Install lockwasher and nut to retain stop ring for both PC and panel mounting. Switch without stop ring has 12 positions.

Soldering, Cleaning and Assembly Instructions for 'MC' Termination Option

Soldering

1. Insert switch base only into PC board.
2. Do not bend terminals.
3. Wave soldering recommended at 500F solder temperature.
4. Hand solder at 500F, 10 sec. max./terminal.

Cleaning

1. Flux clean using vapor degreaser and forced rinse or triple bath method.
2. Do not allow switch base to 'trap' fluids.
3. Freon TMC, TF or Methylene Chloride give excellent results.

Switch Assembly

1. Hold housing/shaft assembly by housing. Remove protective cap by squeezing tabs and discard. (FIG. 1)
2. Do not push on switch shaft. Detent mechanism will come apart.
3. While holding switch housing, align locating tab on base with notch on housing and engage 4 housing latches in slots on base. (FIG. 2)
4. Push firmly on housing until latches snap in place.
5. Remove clip from shaft and discard. Assembly is complete. (FIG. 3)

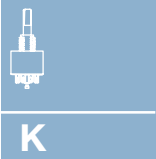
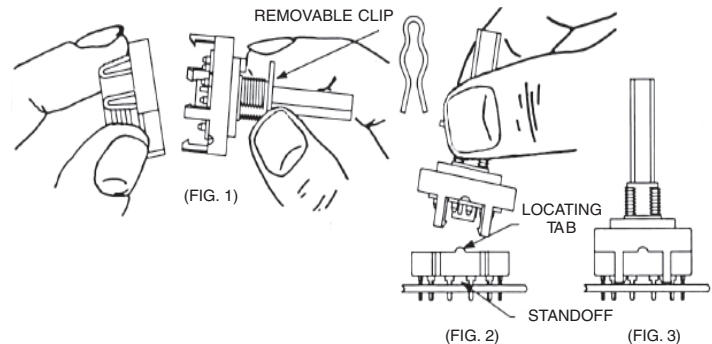

Rotary

AVAILABLE HARDWARE

Stop ring

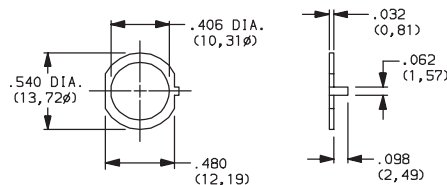

PART NO.

767B00201

Material: Brass

Finish: Nickel plated

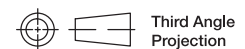

Third Angle Projection

Dimensions are shown: Inch (mm)
Specifications and dimensions subject to change

C&K

RTA Series 1-4 Poles Coded Rotary Switches



Features/Benefits

- PCB or hand soldering versions
- Bushing mounting
- Multiple poles
- Decimal and hexadecimal codes
- Screwdriver slot or extended actuator
- RoHS Compliant

Typical Applications

- Appliances
- Electronic alarm systems
- Medical
- Building automation
- HVAC air conditioning

Electrical Data

| | Silver | Gold |
|---|-------------------|-------------------|
| SWITCHING MODE: | BBM | BBM |
| MAX. SWITCHING POWER | 5 VA | 0.5 VA |
| MAX. SWITCHING CURRENT: | 150 mA | 20 mA |
| MAX. CARRYING CURRENT: | 5 A | 1 A |
| NOMINAL VOLTAGE AT 50 Hz | 60 V | 25 V |
| CONTACT RESISTANCE: | < 150 mΩ | < 150 mΩ |
| DIELECTRIC STRENGTH AT 50 Hz BETWEEN CONTACTS AND GROUND TERMINALS: | 500 V r | 500 V r |
| INSULATION RESISTANCE BETWEEN CONTACTS OR CONTACTS AND FRAME (500 V ⇒): | 10 ⁹ Ω | 10 ⁹ Ω |
| NO. OF OPERATIONS: | 10,000 | 10,000 |
| BOUNCE: | < 5 ms | < 5 ms |

Mechanical Data

MAX. NO. OF BANKS: 1.
 OPERATING TORQUE: 5 Ncm±20%.
 END STOP TORQUE: < 60 Ncm.
 STOP: With/without or adjustable
 MOUNTING: By fixed index 9.5 mm (0.374) of center, for bushing mount only

Materials

BUSHING/HOUSING: PETP Thermoplastic
 STATIONARY CONTACTS & TERMINALS: Nickel Plated Brass with additional plating of Gold or Silver.
 ROTOR: Gold or Silver plated Brass or PCB.
 CODING PLATE: PA thermoplastic
 ACTUATOR: Polysulfon thermoplastic
 HARDWARE: Stop pin: Aluminum. Ball & Spring: Stainless steel. Washer: PA. Nut: Brass.

Environmental Data

OPERATING TEMPERATURE: -20°C to + 70°C -20°C to + 70°C
 STORAGE TEMPERATURE: -40°C to + 85°C -40°C to + 85°C

NOTE: Specifications and materials listed above are for switches with standard options. For information on specific and custom switches, consult Customer Service Center.

Build-A-Switch

To order, simply select desired option from each category and place in the appropriate box. Available options are shown and described on pages K-9 thru K-12. For additional options not shown in catalog, consult Customer Service Center.

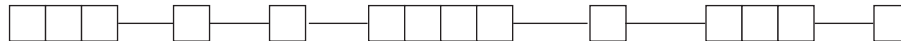

Designation

RTA

Termination

- P** With PC Thru-hole
- H** Horizontal with PC Thru-hole

Indexing

- 2** 22.5 index (coded only)
- 3** 30° index (12 positions max.)
- 4** 36° index (10 positions max.)

Switch Function

- 1W12** SP, 30° Index, 12 pos. no stop
- 1W10** SP, 36° Index, 10 pos. no stop
- 1S02** SP, 30° /36° Index, 2 pos.
- 1S03** SP, 30° /36° Index, 3 pos.
- 1S04** SP, 30° /36° Index, 4 pos.
- 1S05** SP, 30° /36° Index, 5 pos.
- 1S06** SP, 30° /36° Index, 6 pos.
- 1S07** SP, 30° /36° Index, 7 pos.
- 1S08** SP, 30° /36° Index, 8 pos.
- 1S09** SP, 30° /36° Index, 9 pos.
- 1S10** SP, 30° /36° Index, 10 pos.
- 1S11** SP, 30° Index, 11 pos.
- 1S12** SP, 30° Index, 12 pos.
- 2S02** DP, 30° /36° Index, 2 pos.
- 2S03** DP, 30° /36° Index, 3 pos.
- 2S04** DP, 30° /36° Index, 4 pos.
- 2S05** DP, 30° /36° Index, 5 pos.
- 2S06** DP, 30° Index, 6 pos.
- 3S02** 3P, 30° /36° Index, 2 pos.

- 3S03** 3P, 30° /36° Index, 3 pos.
- 4S02** 4P, 30° /36° Index, 2 pos.
- EW10** Direct + complement, 36° Index, no stop
- EW12** Direct + complement, 30° Index, no stop
- DW16** Direct, 22.5° Index, no stop
- ES__** Direct + complement, 30°/36° Index, with stop (specify stop position)
- DS__** Direct, 22.5° Index, with stop (specify stop position)

Mounting Style

- W** Without bushing
- R** 3/8-32 Threaded Bushing
- M** M10x.75 Metric Threaded Bushing
- A** 3/8-32 Threaded Bushing with Offset Bracket
- B** M10x.75 Metric Threaded Bushing with Offset Bracket

Contact Material

- S** Silver plated, matte-tin terminal
- P** Gold plated, matte-tin terminal

Actuator (max.)

- 25N** .984 (25,0) with screwdriver slot
- 50N** 1.97 (50,0) with screwdriver slot
- FLS** Flush shaft with screwdriver slot and position indicator
- 25F** .984 (25,0) Shaft with flat
- 06F** .236 (6,0) Shaft with flat

- C** 3/8-32 Threaded Bushing with Straight Bracket
- D** M10x.75 Metric Threaded Bushing with Straight Bracket



7 nov 16

Dimensions are shown: Inch (mm)
 Specifications and dimensions subject to change

RTA Series 1-4 Poles Coded Rotary Switches

DESIGNATION



RTA

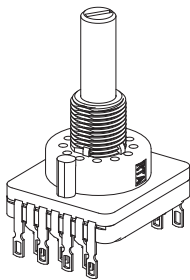

TERMINATION



P

WITH PC PINS

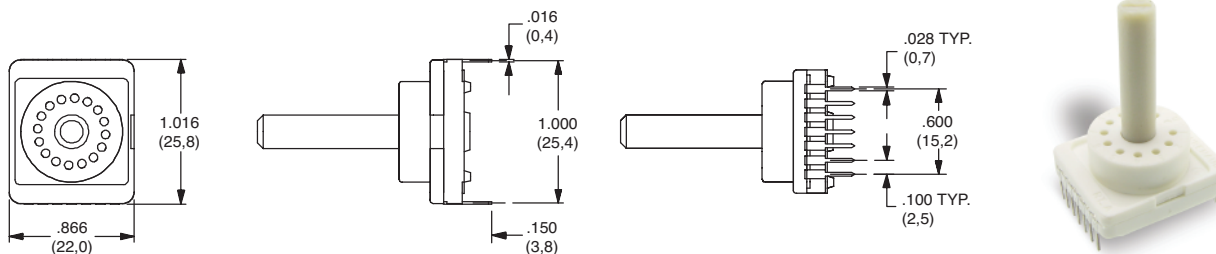

H

Horizontal with PC Thru-hole

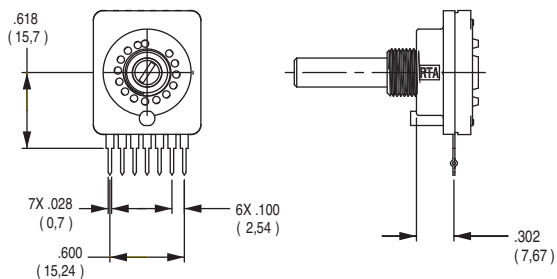

Note: "H" termination only available with the following options:

1. With A or B mounting styles
2. 36° degree indexing
3. Up to 5 positions max

INDEXING



- 2** 22.5 index, 16 positions max.
- 3** 30 index, 12 positions max.
- 4** 36 index, 10 positions max.

Both commons must be connected by user to ground.



Rotary

RTA Series 1-4 Poles Coded Rotary Switches

SWITCH FUNCTION

| NO. POLES | MODEL NO. | SWITCH FUNCTION | INDEX |
|-----------|-------------|----------------------|---------|
| SP | 1W12 | 12 Positions No Stop | 30° |
| | 1W10 | 10 Positions No Stop | 36° |
| | 1S02 | 2 Positions | 30°/36° |
| | 1S03 | 3 Positions | 30°/36° |
| | 1S05 | 5 Positions | 30°/36° |
| | 1S06 | 6 Positions | 30°/36° |
| | 1S08 | 8 Positions | 30°/36° |
| | 1S09 | 9 Positions | 30°/36° |
| | 1S10 | 10 Positions | 30°/36° |
| | 1S11 | 11 Positions | 30° |
| | 1S12 | 12 Positions | 30° |

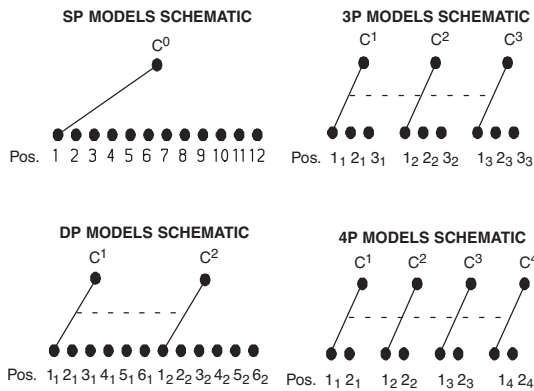

| MODEL NO. | SWITCH FUNCTION | INDEX |
|-------------|--|-----------|
| EW10 | Direct + complement, No stop | 36° |
| EW12 | Direct + complement, No stop | 30° |
| DW16 | Direct, No stop | 22.5° |
| ES__ | Direct + complement, with stop (specify stop position) | 30° & 36° |
| DS__ | Direct, with stop (specify stop position) | 22.5° |

| NO. POLES | MODEL NO. | SWITCH FUNCTION | INDEX |
|-------------|-------------|---------------------|-------------|
| DP | 2W05 | 5 Positions No Stop | 30°/36° |
| | 2W06 | 6 Positions No Stop | 30° |
| | 2S02 | 2 Positions | 30°/36° |
| | 2S03 | 3 Positions | 30°/36° |
| | 2S04 | 4 Positions | 30°/36° |
| | 2S05 | 5 Positions | 30°/36° |
| | 2S06 | 6 Positions | 30° |
| | 3P | 3S02 | 2 Positions |
| 3S03 | | 3 Positions | 30°/36° |
| 4P | 4S02 | 2 Positions | 30°/36° |

| 22.5° | 30° | 36° | | Pos. | 1 | 2 | 3 | 4 | 5 | 6 | 7 | 8 | 9 | 10 | 11 | 12 | 13 | 14 | 15 | 16 | |
|-------|-------|-------|---|------|---|---|---|---|---|---|---|---|---|----|----|----|----|----|----|----|---|
| Term. | Term. | Term. | | | | | | | | | | | | | | | | | | | |
| E,J | M,N | L,N | C | | * | * | * | * | * | * | * | * | * | * | * | * | * | * | * | * | * |
| F,I | H | D | 1 | | | * | | | | * | | * | | * | | * | | * | | * | |
| D,K | D | B | 2 | | | | * | * | | | * | * | | | * | * | | | * | * | |
| A,N | A | I | 4 | | | | | * | * | * | * | | | | | * | * | * | * | * | * |
| B | J | J | 8 | | | | | | | | | * | * | * | * | * | * | * | * | * | * |
| - | C | K | 1 | | * | | * | | * | | * | | * | | * | | * | | * | | * |
| - | K | H | 2 | | * | * | | | * | * | | | * | * | | * | * | | | * | * |
| - | B | A | 4 | | * | * | * | * | | | | * | * | * | * | | * | * | | | * |
| - | I | C | 8 | | * | * | * | * | * | * | * | * | * | * | * | * | * | * | * | * | * |

Indexing Option Code 2, 22.5 INDEXING ANGLE PCB LAYOUT

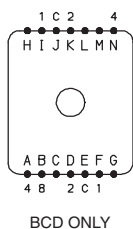

BCD ONLY

Indexing Option Code 3, 30 INDEXING ANGLE PCB LAYOUT

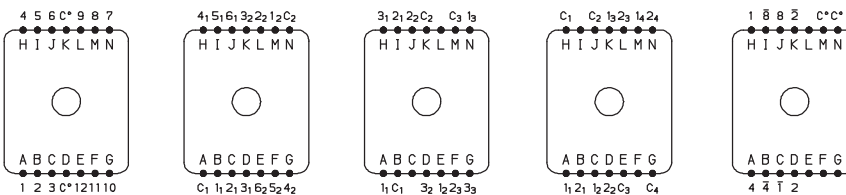

1 POLE

2 POLES

3 POLES

4 POLES

BCD + COMPLEMENTS

Indexing Option Code 4, 36 INDEXING ANGLE PCB LAYOUT

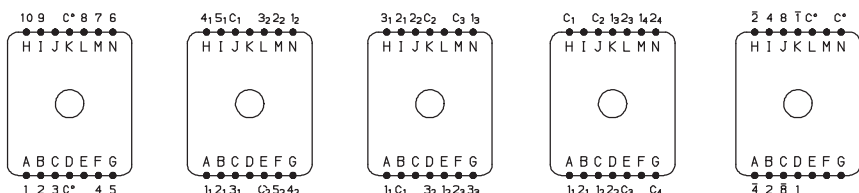

1 POLE

2 POLES

3 POLES

4 POLES

BCD + COMPLEMENTS

NOTE: Layout view from component side.

Common terminals that are in locations A-G are not connected to common terminals that are in locations H-N. For 7-12 position output customer must tie these commons together.

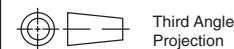

Third Angle Projection

Dimensions are shown: Inch (mm)
Specifications and dimensions subject to change



7 nov 16

RTA Series 1-4 Poles Coded Rotary Switches

MOUNTING STYLE

W WITHOUT BUSHING

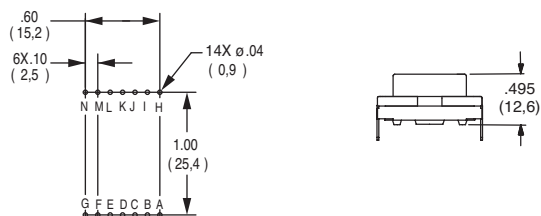

Note: W mounting style not available with H termination.

M M10 x .75 METRIC THREADED BUSHING

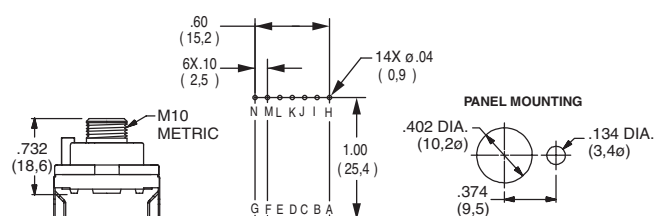

Note: M mounting style not available with H termination.

R 3/8-32 THREADED BUSHING

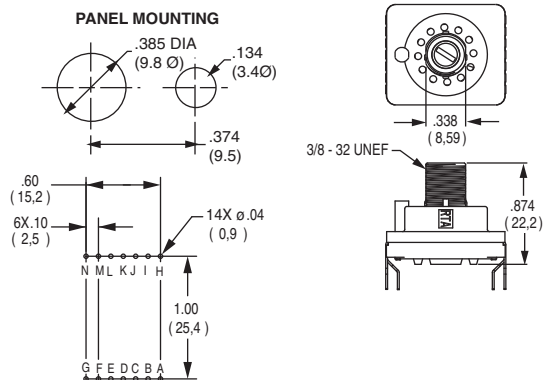

Note: R mounting style not available with H termination.

A 3/8-32 THREADED BUSHING WITH BRACKET

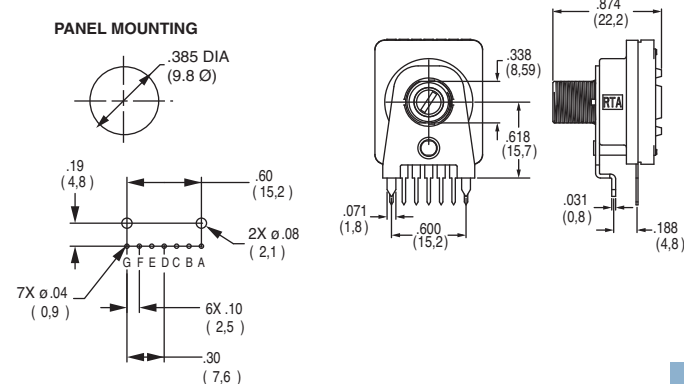

Note: A mounting style only available with H termination.

B M10 x .75 METRIC THREADED BUSHING WITH BRACKET

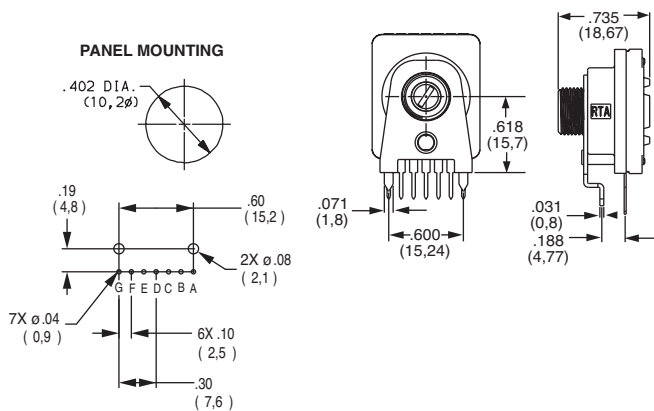

Note: B mounting style only available with H termination.

C 3/8-32 THREADED BUSHING WITH STRAIGHT BRACKET

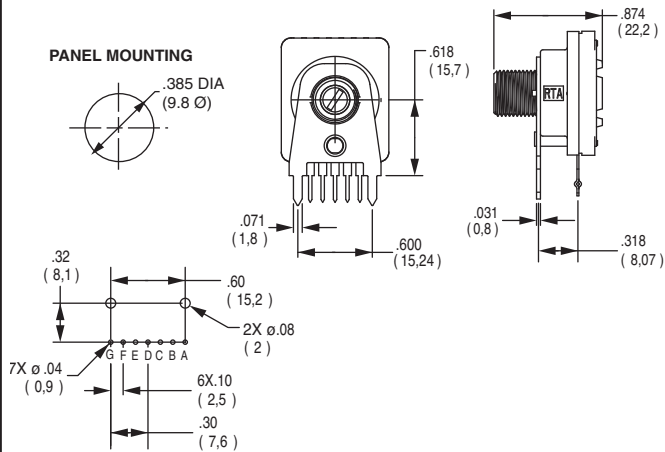

D M10 x .75 METRIC THREADED BUSHING WITH STRAIGHT BRACKET

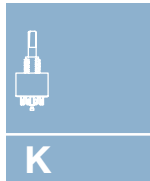
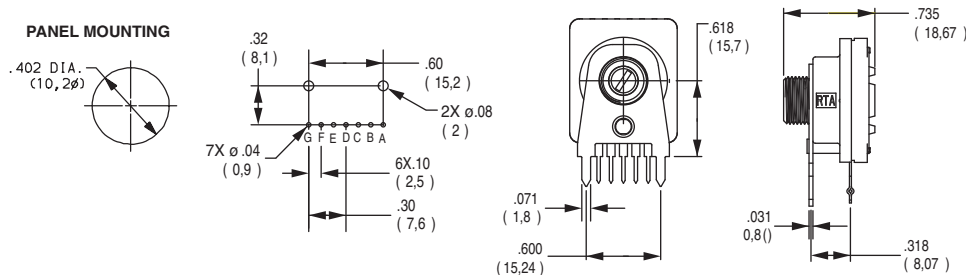

K

Rotary

RTA Series 1-4 Poles Coded Rotary Switches

ACTUATOR

25N .984 (25,0) WITH SCREWDRIVER SLOT

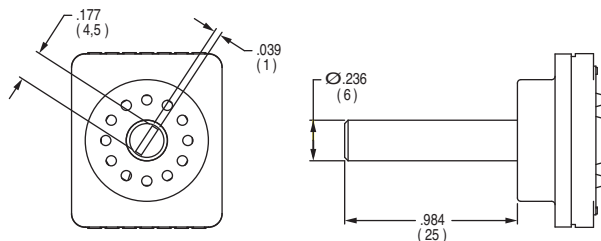

50N 1.97 (50,0) WITH SCREWDRIVER SLOT

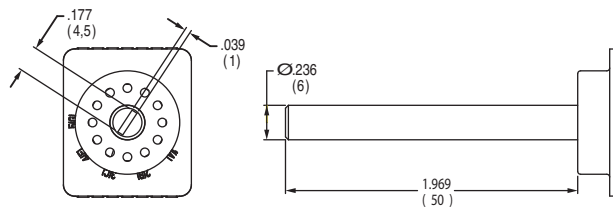

FLS FLUSH SHAFT WITH SCREWDRIVER SLOT AND POSITION INDICATOR

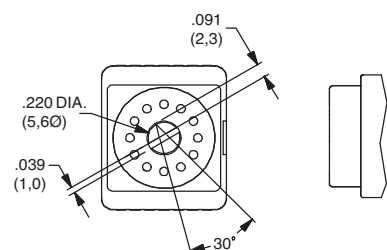

Note: only available with "W" Mounting Style

25F .984 (25,0) SHAFT WITH FLAT

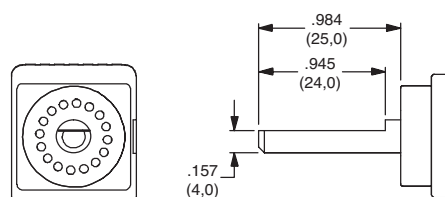

Note: only available with "W" Mounting Style

06F .236 (6,0) SHAFT WITH FLAT

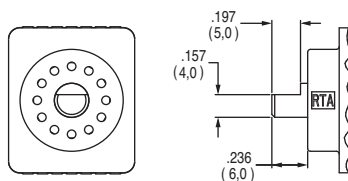

Note: only available with "W" Mounting Style

CONTACT MATERIAL

| OPTION CODE | CONTACT AND TERMINAL MATERIAL | RATING | |
|-------------|-------------------------------|--------------------------------|--|
| S | SILVER | LOW LEVEL/DRY CIRCUIT | SWITCH: 150 mA MAXIMUM, 60 V NOMINAL. POWER: 5 VA MAXIMUM. CARRY-5 AMPS MAXIMUM. |
| P | GOLD | LOW LEVEL/DRY CIRCUIT OR POWER | SWITCH: 20 mA MAXIMUM, 25 V NOMINAL. POWER: 0.5 VA MAXIMUM. CARRY: 1 AMP MAXIMUM. |

* Note: See Technical Data section of this catalog for RoHS compliant and compatible definition and specifications.

AVAILABLE HARDWARE

Mounting Nuts

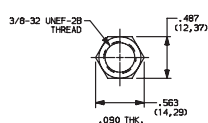

PART NO.
472706201
Standard

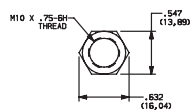

PART NO.
495100201
Metric

Stop pins



PART NO.
Y200300200PCH

Lockwasher

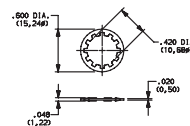

PART NO.
472800202

NOTE: Additional nuts and lockwashers available separately, see section "Technical Data and Additional Hardware".



Third Angle
Projection

Dimensions are shown: Inch (mm)
Specifications and dimensions subject to change



K

Rotary

M Series Half-inch Rotary Switches

Features/Benefits

- Multi-pole and multi-positions
- Panel and PCB mounting
- Stainless steel actuator
- Non-shorting contacts
- RoHS Compliant
- IP67 (F option only)

Typical Applications

- Test equipment
- Industrial equipment
- Medical equipment



C&K[®]
US

Models Available

Specifications

CONTACT RATING: Q contact material: Carry-6 AMPS continuous. Switch-250 mA max. @ 125 V AC or 28 DC. Non-shorting contacts standard. See page K-16 for additional ratings.

ELECTRICAL LIFE: 10,000 make-and-break cycles at 150 mA, 125 V AC or 28 DC.

CONTACT RESISTANCE: Below 20 mΩ typ. initial @ 2-4 V DC, 100 mA, for both silver and gold plated contacts.

INSULATION RESISTANCE: 10¹⁰ Ω min.

DIELECTRIC STRENGTH: 600 Vrms min. @ sea level.

OPERATING & STORAGE TEMPERATURE: -30°C to 85°C.

OPERATING TORQUE: 4-7 ounces-inches typ. initial.

SOLDERABILITY: Per MIL-STD-202F method 208D, or EIA RS-186E method 9 (1 hour steam aging).

NOTE: Specifications and materials listed above are for switches with standard options. For information on specific and custom switches, consult Customer Service Center.

Materials

HOUSING AND BUSHING: Zinc alloy, bright zinc plated, with clear chromate finish.

ACTUATOR: Zinc alloy, nickel plated or stainless steel.

BASE: Diallylphthalate (DAP) or melamine phenolic, with insert molded terminals.

ROTOR: Glass filled polyester (UL 94V-0).

MOVABLE CONTACTS:
Non-shorting: Q contact material: Copper alloy, silver plated. See page K-16 for additional contact materials.

STATIONARY CONTACT & ALL TERMINALS: Q contact material: Copper alloy, silver plated. All terminals insert molded. All terminals present regardless of number of switch positions. See page K-16 for additional contact materials.

CONTACT SPRING: Music wire, phosphate coated.

STOP PIN: Stainless steel.

STOP RING: Brass.

HARDWARE: Nut: Brass, nickel plated; Lockwasher: Steel, nickel plated.

Build-A-Switch

To order, simply select desired option from each category and place in the appropriate box. Available options are shown and described on pages K-14 thru K-17. For additional options not shown in catalog, consult Customer Service Center.

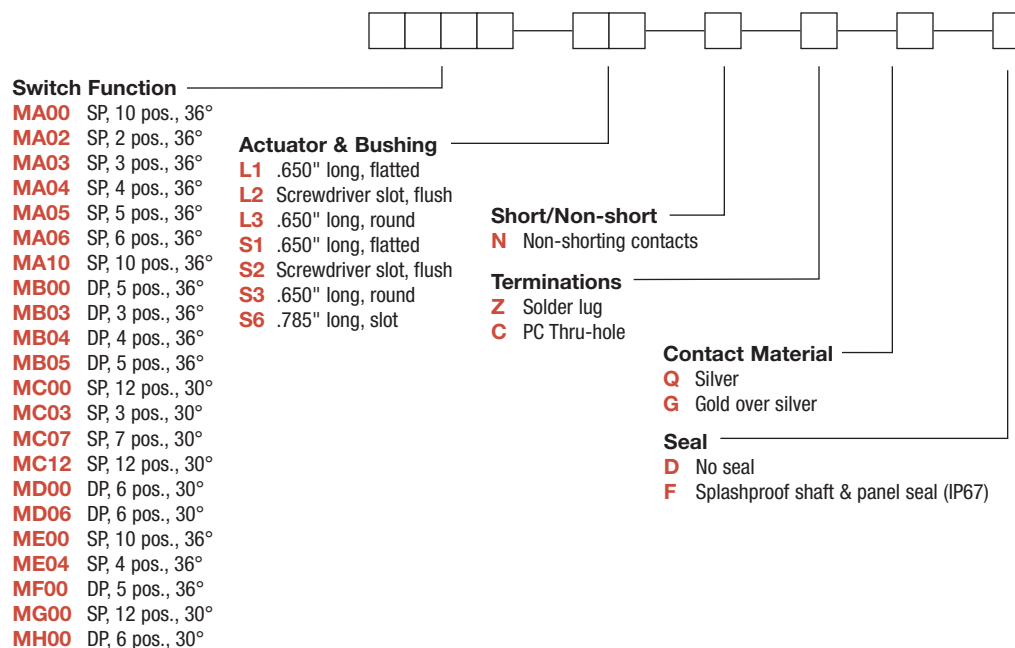

Dimensions are shown: Inch (mm)
Specifications and dimensions subject to change

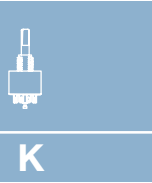

Rotary

M Series Half-inch Rotary Switches

SWITCH FUNCTION

| 36° INDEXING | | | |
|--------------|--------------------------|---------------------------|-----------------------|
| NO. POLES | MODEL NO. WITH STOP PINS | MODEL NO. WITH STOP RINGS | SWITCH FUNCTION |
| SP | MA00 | ME00 | 10 Positions No Stops |
| | MA02 | — | 2 Positions |
| | MA03 | — | 3 Positions |
| | MA04 | ME04 | 4 Positions |
| | MA05 | — | 5 Positions |
| | MA06 | — | 6 Positions |
| | MA10 | — | 10 Positions |
| DP | MB00 | MF00 | 5 Positions No Stops |
| | MB03 | — | 3 Positions |
| | MB04 | — | 4 Positions |
| | MB05 | — | 5 Positions |

SP MODELS 36° INDEXING SCHEMATIC

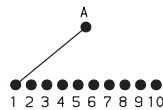

DP MODELS 36° INDEXING SCHEMATIC

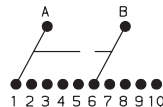

| 30° INDEXING | | | |
|--------------|--------------------------|---------------------------|-----------------------|
| NO. POLES | MODEL NO. WITH STOP PINS | MODEL NO. WITH STOP RINGS | SWITCH FUNCTION |
| SP | MC00 | MG00 | 12 Positions No Stops |
| | MC03 | — | 3 Positions |
| | MC07 | — | 7 Positions |
| | MC12 | — | 12 Positions |
| DP | MD00 | MH00 | 6 Positions No Stops |
| | MD06 | — | 6 Positions |

SP MODELS 30° INDEXING SCHEMATIC

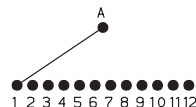

DP MODELS 30° INDEXING SCHEMATIC

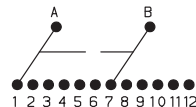

All models  with all options when ordered with S1-S6 stainless steel actuator options.

NOTE: Number of positions or stops preset at factory (NOTE: MX00 models have full 360 rotation with no stops. Stop pins or stop rings supplied for user-selectable stops, see above). All terminals present regardless of number of switch positions. Hardware is available separately, see section "Technical Data and Additional Hardware".

Rotary

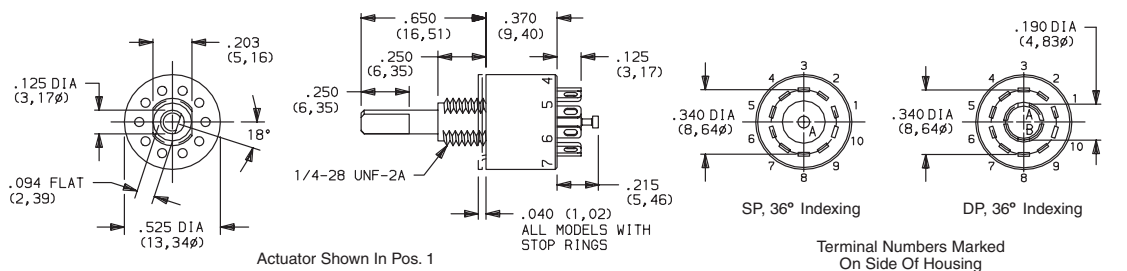

Part number shown: MA00L1NZQD

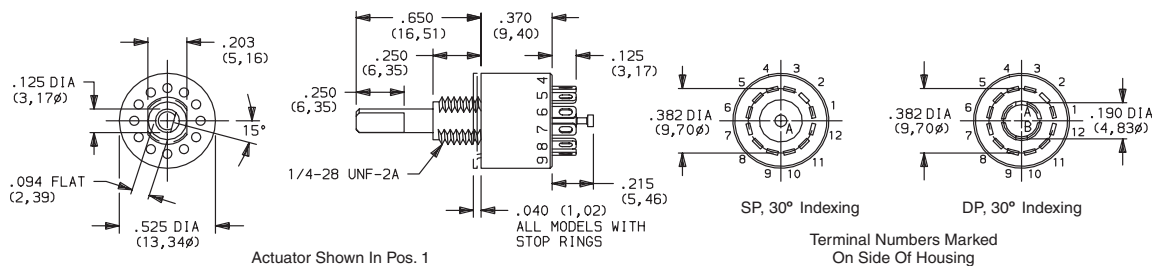

Part number shown: MC00L1NZQD

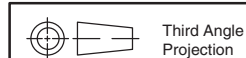

Dimensions are shown: Inch (mm)
Specifications and dimensions subject to change



M Series Half-inch Rotary Switches

ACTUATOR (ZINC ALLOY)



L1 .650" LONG, FLATTED

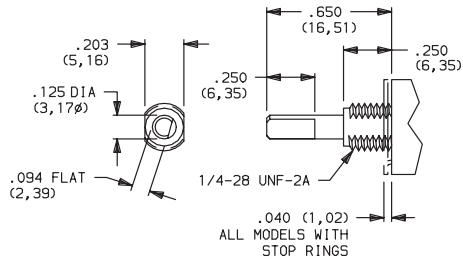

L2 SCREWDRIVER SLOT, FLUSH

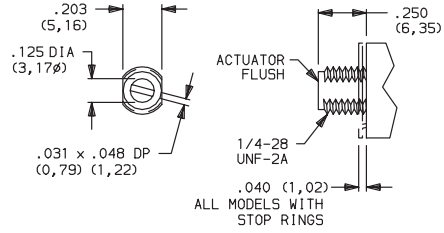

L3 .650" LONG, ROUND

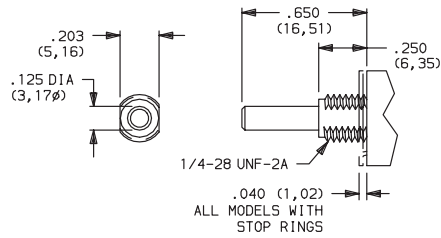

All actuators shown in pos. 1

ACTUATOR (STAINLESS STEEL)



S1 .650" LONG, FLATTED

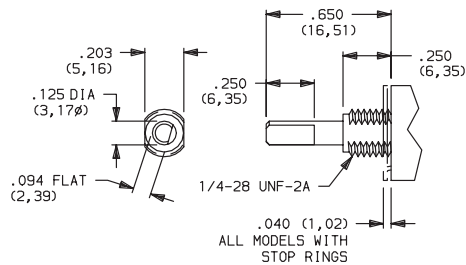

S2 SCREWDRIVER SLOT, FLUSH

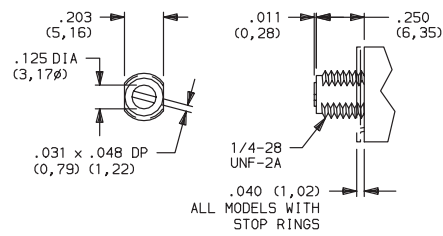

S3 .650" LONG, ROUND

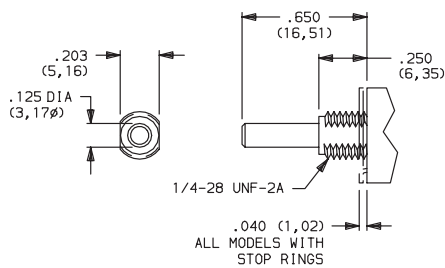

S6 .785" LONG, SLOT

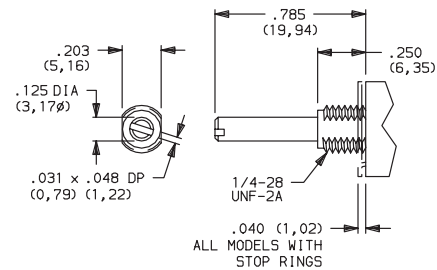

All actuators shown in pos. 1

All models  when ordered with stainless steel actuators.



Third Angle
Projection



K

Rotary

M Series Half-inch Rotary Switches

SHORTING/NON-SHORTING CONTACTS

N NON-SHORTING CONTACTS

Break-before-make

TERMINATIONS

Z SOLDER LUG

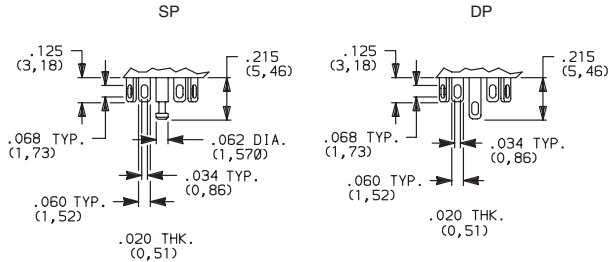

C PC THRU-HOLE

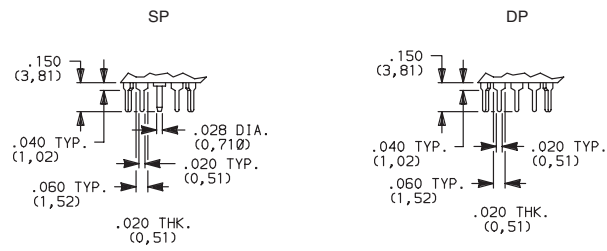

PANEL MOUNTING

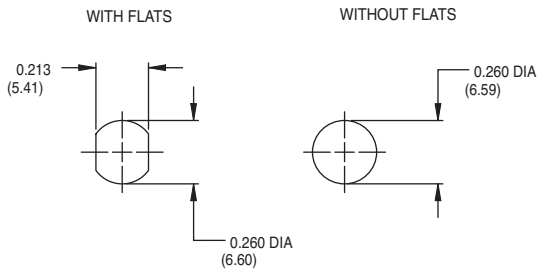

PC MOUNTING 36° INDEXING

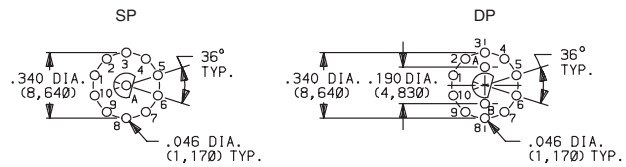

PC MOUNTING 30° INDEXING

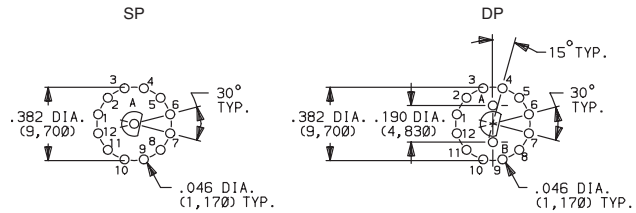

Rotary

Hardware: All models, one mounting nut and lockwasher supplied standard. MA00 thru MD00 models: two stop pins and adhesive mylar washer supplied. ME00 thru MH00 models: two stop rings supplied. Hardware is available separately, see section "Technical Data and Additional Hardware".

* Will withstand 12 in. - lbs of torque with no distortion.

NOTE: Q contact material standard. Terminal numbers marked on side of housing. All terminals insert molded. All terminals present regardless of number of switch positions.

Actuators and schematics shown in pos. 1.

CONTACT MATERIAL

| OPTION CODE | CONTACT MATERIAL | TERMINAL PLATING | RATING | |
|-------------|---------------------------------|---------------------|--------------------------------|--|
| | | | POWER | CARRY: 6 AMPS CONTINUOUS. SWITCH: 250 mA @ 125 V AC or 28 V DC. |
| Q | SILVER ^{1,2} | SILVER ² | LOW LEVEL/DRY CIRCUIT OR POWER | 0.4 VA MAX. @ 20 V AC or DC MAX. or, CARRY: 6 AMPS CONTINUOUS. SWITCH: 250 mA @ 125 V AC or 28 V DC. |
| G | GOLD OVER SILVER ^{3,4} | GOLD ⁴ | | |

* Note: See Technical Data section of this catalog for RoHS compliant and compatible definition and specifications.

¹ MOVABLE CONTACTS: Non-shorting: Copper alloy, silver plated.

² STATIONARY CONTACTS & ALL TERMINALS: Copper alloy, silver plated.

³ MOVABLE CONTACTS: Non-shorting: Copper alloy, with gold plate over nickel plate, over silver plate.

⁴ STATIONARY CONTACTS & ALL TERMINALS: Copper alloy, with gold plate over nickel plate over silver plate.

NOTE: Any models supplied with Q, G contact material are RoHS compliant.

All models  us when ordered with S1-S6 stainless steel actuator options.



Third Angle
Projection

Dimensions are shown: Inch (mm)
Specifications and dimensions subject to change

C&K

M Series Half-inch Rotary Switches

SEAL 

D NO EPOXY SEAL

F SPLASHPROOF SHAFT AND PANEL SEAL
IP67 approved

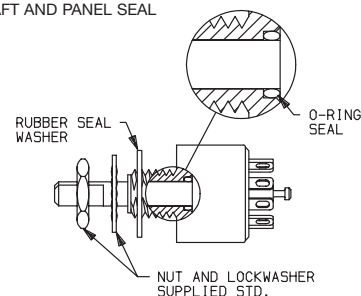

Setting Stops With Stop Pins

MA00, MB00, MC00 & MD00 Models Only:

The number of switch positions or stops are adjustable by means of stop pins provided with each switch. Switches are normally shipped with stop pins and hardware in bulk, not installed. Without stop pins, switches have full 360° rotation and no stops. Note that all two pole models begin to repeat when actuated 180° or more.

To set stops, refer to figures 1 & 2. Orient switch so that terminal no. 1 is as shown. Turn actuator to position 1, using flats on bushing and terminal no. 1 as reference. Install CCW stop pin in hole designated 'X'. Install second stop pin in hole number corresponding to the number of positions desired. Note that two pole models will begin to repeat when actuated 180° or more. To retain stop pins, use adhesive mylar washer included; see figure 3.

All models except MX00 models have number of switch positions or stops pre-set at factory and are not adjustable.

Hardware:

Two stop pins, mounting nut, and lockwasher supplied standard.

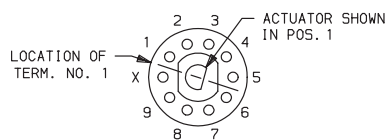

36° Indexing Models
Top View

Fig. 1

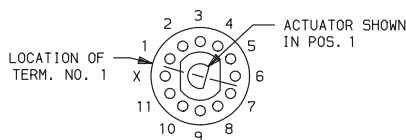

30° Indexing Models
Top View

Fig. 2

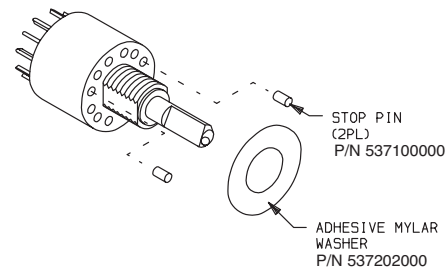

Fig. 3

Setting Stops With Stop Rings

ME00, MF00, MG00 & MH00 Models Only:

The number of switch positions or stops are adjustable by means of stop rings provided with each switch. These models are normally shipped with stop rings and hardware in bulk, not installed. Without stop rings, switches have full 360° rotation and no stops. Note that all two pole models begin to repeat when actuated 180° or more.

To set stops refer to figures 4 & 5. Orient switch so that terminal no. 1 is as shown. Turn actuator to pos. 1 using flats on bushing and terminal no. 1 as reference. See figure 6 and install inner stop ring with short tab in hole designated 'X'. Install outer stop ring with long tab in hole number corresponding to the number of positions desired. Note that all two pole models begin to repeat when actuated 180° or more. Use mounting nut and lockwasher to retain stop rings.

All MEXX, MFXX, MGXX & MHXX Models (Except MX00 models):

Number of switch positions or stops are preset at factory, but are user adjustable.

Hardware:

Two stop rings, mounting nut and lockwasher supplied standard.

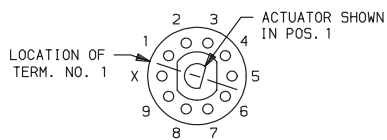

36° Indexing Models
Top View

Fig. 4

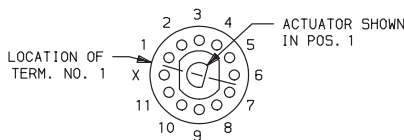

30° Indexing Models
Top View

Fig. 5

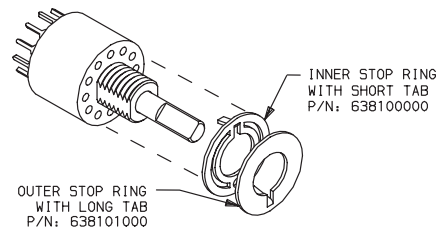
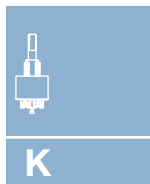

Fig. 6



R Series ROTA-SLIDE® Rotary Switches



Models Available

Features/Benefits

- Multi-pole and multi-position
- Positive detent
- Panel and PCB mounting
- Enclosed
- RoHS Compliant

Typical Applications

- Ceiling fans
- Industrial equipment
- Portable tools

Specifications

CONTACT RATING: Q contact material: 5 AMPS @ 125 V AC; 2.5 AMPS @ 250 V AC; 0.5 AMP @ 125 V DC; 1/8 HP @ 125 and 250 VAC (UL/CSA).

See page K-20 for additional ratings.

ELECTRICAL LIFE: 10,000 make-and-break cycles at full load.

CONTACT RESISTANCE: Below 10 m Ω typ. initial @ 2-4 V DC, 100 mA, for both silver and gold plated contacts.

INSULATION RESISTANCE: 10⁹ Ω min.

DIELECTRIC STRENGTH: 1,000 Vrms min. @ sea level.

INDEXING: 36°-one contact models, 10 position max.; two contact models, 5 position max.

OPERATING & STORAGE TEMPERATURE: -30°C to 95°C

Materials

HOUSING & BUSHING: 6/6 nylon (UL 94V-2).

ACTUATOR: 6/6 nylon (UL 94V-2).

CONTACTS & TERMINALS: Q contact material: Copper, silver plated. See page K-20 for additional contact materials.

CONTACT SPRING: Music wire or stainless steel.

MOUNTING NUT: Steel, zinc plated.

TERMINAL SEAL: Epoxy.

NOTE: Any models supplied with Q or B contact material are RoHS compliant.

NOTE: Specifications and materials listed above are for switches with standard options. For information on specific and custom switches, consult Customer Service Center.

Build-A-Switch

To order, simply select desired option from each category and place in the appropriate box. Available options are shown and described on pages K-19 and K-20. For additional options not shown in catalog, consult Customer Service Center.



Switch Function

- R100** SP, 36° Index, 10 pos. no stops
- R103** SP, 36° Index, 3 pos.
- R104** SP, 36° Index, 4 pos.
- R108** SP, 36° Index, 8 pos.
- R203** DP, 36° Index, 3 pos.
- R204** DP, 36° Index, 4 pos.
- R205** DP, 36° Index, 5 pos.

Actuator

- 07** .500" high with .156" flat
- 05** .375" high with .156" flat
- 15** Screwdriver slot without bushing

Mounting Style

- RR** 3/8-32 threaded bushing
- RN** PC without bushing
- RS** PC without bushing

Terminations

- 03** Solder lug with hole
- 01** Solder lug with notch
- 02** PC Thru-hole
- WC** Wire Lead

Contact Material

- Q** Silver
- B** Gold

Seal

- NONE** No seal
- E** Epoxy seal



K

Rotary



Dimensions are shown: Inch (mm)
Specifications and dimensions subject to change

R Series ROTA-SLIDE® Rotary Switches

SWITCH FUNCTION

| SP MODELS 36° INDEXING | | | |
|------------------------|-----------|-------------------------|--------------------|
| NO. POLES | MODEL NO. | SWITCH FUNCTION | TERMINALS |
| SP | R100 | 10 Position No Stops | All Terminals |
| | R103 | 3 Position | 10-1-2-3 |
| | R104 | 4 Position | 10-1-2-3-4 |
| | R108 | 8 Position | 10-1-2-3-4-5-6-7-8 |

SP MODELS 36° INDEXING
SCHEMATIC

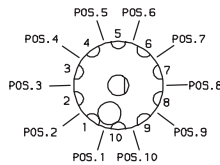

| DP MODELS 36° INDEXING | | | |
|------------------------|-----------|-----------------|------------------|
| NO. POLES | MODEL NO. | SWITCH FUNCTION | TERMINALS |
| DP | R203 | 3 Position | 10-1-2-3-5-6-7-8 |
| | R204 | 4 Position | All Terminals |
| | R205 | 5 Position | All Terminals |

DP MODELS 36° INDEXING
SCHEMATIC

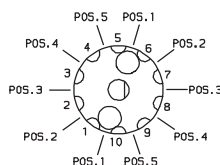

All models with all options when ordered with 'Q' contact material.

NOTE: Break-before-make contacts. Actuators and contacts are shown in position 1. No common terminal is present. Switching function is provided by movable contacts shorting adjacent pairs of stationary contacts.

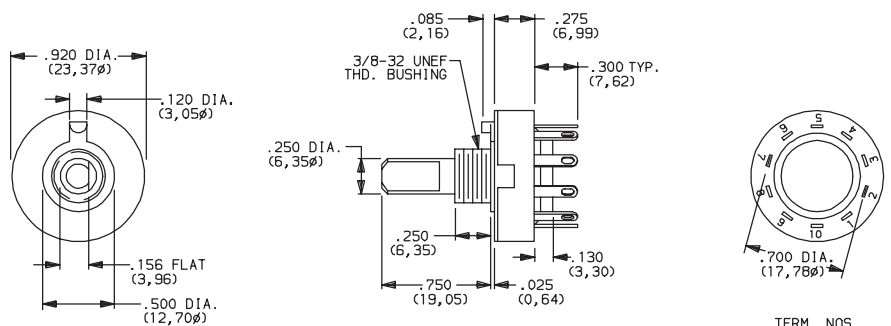

TERM. NOS.
MOLDED ON HOUSING

Part number show: R10007RR03Q

ACTUATOR

07 .500" HIGH WITH .156" FLAT

05 .375" HIGH WITH .156" FLAT

15 SCREWDRIVER SLOT

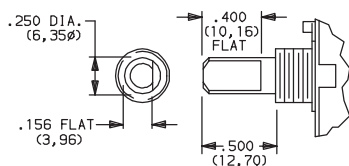

Shown with 'RR' mounting style. For mounting styles without bushing, add .250 (6,35) to actuator length.

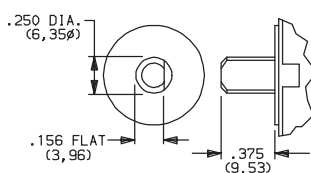

Shown with 'RN' mounting style.

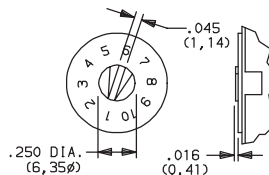

Arrow on actuator marked red (std.). Shown with 'RS' mounting style.



Third Angle
Projection



Dimensions are shown: Inch (mm)
Specifications and dimensions subject to change



R Series ROTA-SLIDE® Rotary Switches

MOUNTING STYLE

RR 3/8-32 THREADED BUSHING

RN PC WITHOUT BUSHING

RS PC SCREWDRIVER SLOT WITHOUT BUSHING

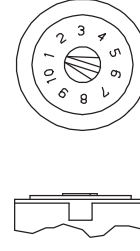
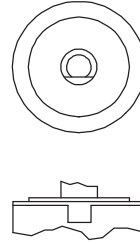
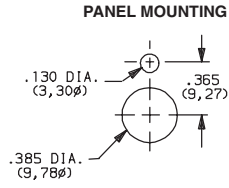
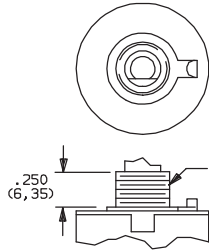

Position numbers and characters are molded on housing.

Mounting nut included (part number 175000100).

TERMINATIONS

03 SOLDER LUG WITH HOLE

01 SOLDER LUG WITH NOTCH

02 PC THRU-HOLE

WC WIRE LEAD

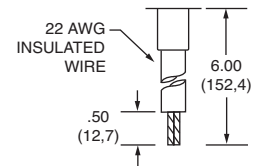
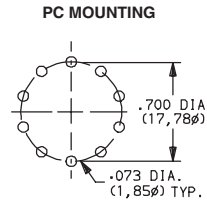
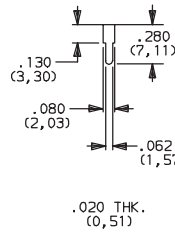
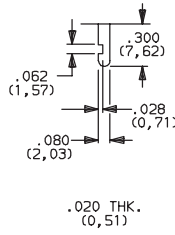
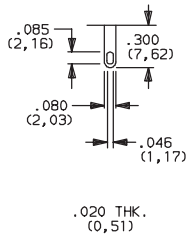

K

Rotary

CONTACT MATERIAL

| OPTION CODE | CONTACT AND TERMINAL MATERIAL | RATING | |
|-------------|-------------------------------|-----------------------|--|
| | | | |
| Q | SILVER ² | POWER | 5 AMPS @ 125 V AC; 2.5 AMPS @ 250 V AC; 0.5 AMP @ 125 V DC (UL/CSA); 1/8 HP @ 125 and 250 VAC (UL/CSA). |
| B | GOLD ¹ | LOW LEVEL/DRY CIRCUIT | 0.4 VA MAX. @ 20 V AC or DC MAX. |

* Note: See Technical Data section of this catalog for RoHS compliant and compatible definition and specifications.

¹ CONTACTS & TERMINALS: Copper, with gold plate over nickel plate.
² CONTACTS & TERMINALS: Copper, silver plated. (Standard with all termination options.)

NOTE: Any models supplied with Q, B or G contact material are RoHS compliant.

All models  with all options when ordered with 'Q' contact material.

SEAL

NONE NO SEAL

E EPOXY SEAL

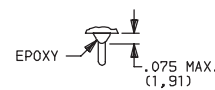

Dimensions are shown: Inch (mm)
Specifications and dimensions subject to change

F Series Miniature ROTA-SLIDE® Rotary Switches

Features/Benefits

- Multi-pole and multi-position
- Panel and PCB mounting
- Positive detent
- Value added capability
- RoHS Compliant

Typical Applications

- Small appliances
- Testing fixtures
- Safety equipment



Models Available

Specifications

CONTACT RATING: Q contact material: 4 AMPS @ 125 V AC or 28 V DC; 2 AMPS @ 250 V AC (UL/CSA). See page K-24 for additional ratings.

ELECTRICAL LIFE: 10,000 make-and-break cycles at full load.

CONTACT RESISTANCE: Below 10 m Ω typ. initial @ 2-4 V DC, 100 mA, for both silver and gold plated contacts.

INSULATION RESISTANCE: 10⁹ Ω min.

DIELECTRIC STRENGTH: 1,000 Vrms min. @ sea level.

INDEXING: 45° or 90° -one contact models; two contact models, 4 pos. max. Models with common terminal -90°, 4 pos. max.

OPERATING & STORAGE TEMPERATURE: -30°C to 65°C

Materials

HOUSING & BUSHING: 6/6 Nylon (UL 94V-2).

ACTUATOR: 6/6 nylon (UL 94V-2).

CONTACTS: Q contact material: Copper, silver plated. See page K-24 for additional contact materials.

TERMINALS: Q contact material: Copper, silver plated. See page K-24 for additional contact materials.

CONTACT SPRING: Music wire or stainless steel.

MOUNTING NUT: Brass, nickel plated.

TERMINAL SEAL: Epoxy.

NOTE: Any models supplied with Q or B contact material are RoHS compliant.

NOTE: Specifications and materials listed above are for switches with standard options. For information on specific and custom switches, consult Customer Service Center.

Build-A-Switch

To order, simply select desired option from each category and place in the appropriate box. Available options are shown and described on pages K-22 thru K-24. For additional options not shown in catalog, consult Customer Service Center.

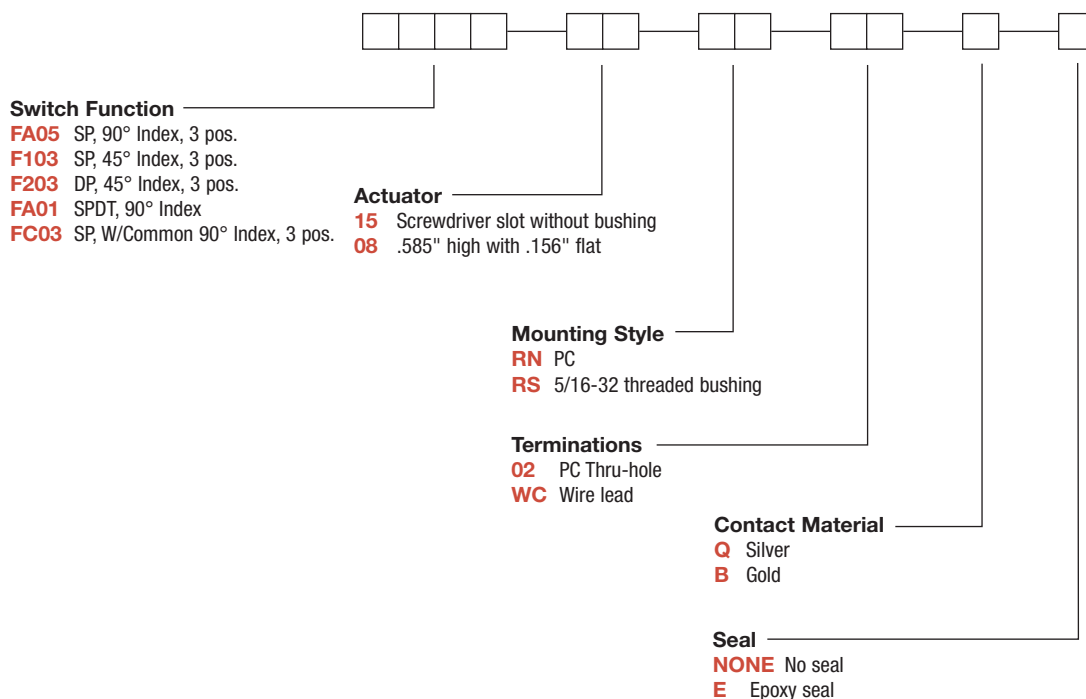

Dimensions are shown: Inch (mm)
Specifications and dimensions subject to change



Rotary

F Series Miniature ROTA-SLIDE® Rotary Switches

SWITCH FUNCTION

| 45° INDEXING | | | |
|--------------|-------------|-----------------|---------------|
| NO. POLES | MODEL NO. | SWITCH FUNCTION | TERMINALS |
| SP | F103 | 3 Position | 8-1-2-3* |
| DP | F203 | 3 Position | All Terminals |

45° INDEXING SCHEMATICS

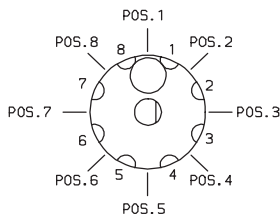

F1XX MODELS

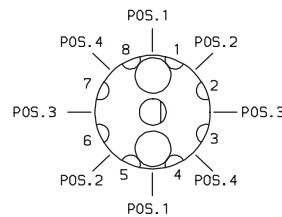

F2XX MODELS

Break-before-make contacts. Terminal numbers are molded on bottom of housing. Actuators are shown in position 1.

NOTE: *Switches with '02' PC terminations have additional terminal no. 5 as switch support only. This terminal is not connected electrically inside switch.

F1XX, F2XX models: No common terminal is present. Switching function is provided by movable contacts shorting adjacent pairs of stationary contacts.

| 90° INDEXING | | | |
|----------------|-------------|-----------------|-------------|
| NO. POLES | MODEL NO. | SWITCH FUNCTION | TERMINALS |
| SP | FA01 | SPDT | 8-1-3 |
| | FA05 | 3 Position | 8-1-3-5 |
| SP WITH COMMON | FC03 | 3 Position | C-1,C-2,C-3 |

90° INDEXING SCHEMATICS

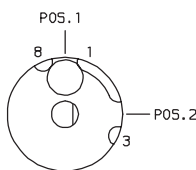

FA01 MODEL

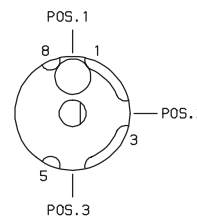

FA05 MODEL

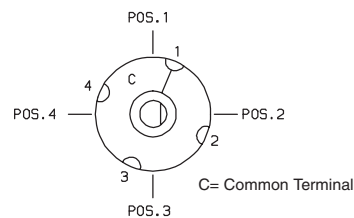

FCXX MODEL

Break-before-make contacts. Terminal numbers are molded on bottom of housing. Actuators are shown in position 1.

FCXX models: Common terminal is present.

FAXX models: No common terminal is present. Switching function is provided by movable contacts shorting adjacent pairs of stationary contacts.

NOTE: *Switches with '02' PC terminations have additional terminal no. 5 as switch support only. This terminal is not connected electrically inside switch.

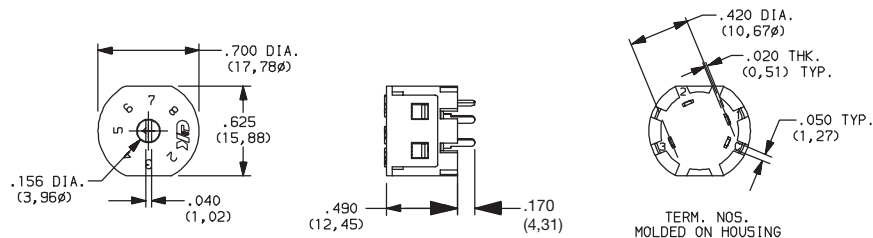

Part number show: FC0315RN02Q

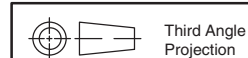

Third Angle Projection

Dimensions are shown: Inch (mm)
Specifications and dimensions subject to change



K

Rotary

F Series Miniature ROTA-SLIDE® Rotary Switches

ACTUATOR

15 SCREWDRIVER SLOT WITHOUT BUSHING

08 .585" HIGH WITH .156" FLA

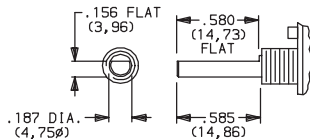
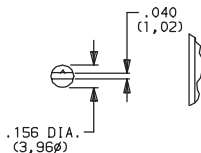

Shown with 'RN' mounting style; not available with 'RS' mounting style or FCXX models.

Must be ordered with 'RS' mounting style.

MOUNTING STYLE

RN PC

RS 5/16-32 THREADED BUSHING



PC mount, no bushing, position numbers molded standard. Shown with '15' actuator; not available with '08' actuator or FCXX models.



Panel mount, with 5/16 in.-32 threaded bushing. Mounting nut (P/N 175020201) included. Must be ordered with '08' actuator option.

PANEL MOUNTING

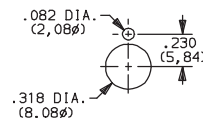

5/16 IN. BUSHING

TERMINATIONS

02 PC THRU-HOLE

WC WIRE LEAD

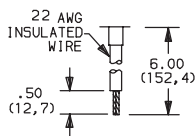
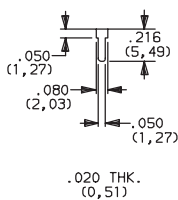

Black wire standard, other colors and lengths available, consult Customer Service Center. UL style 1015.

F1XX, F2XX & FAXX Models

02 PC THRU-HOLE

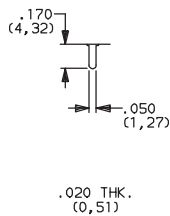

FCXX Models

PC MOUNTING

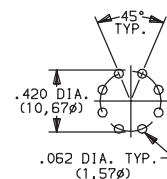

 Third Angle Projection

Dimensions are shown: Inch (mm)
Specifications and dimensions subject to change

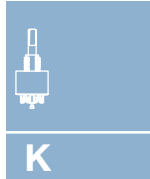

Rotary

F Series Miniature ROTA-SLIDE® Rotary Switches

CONTACT MATERIAL

| OPTION CODE | CONTACT AND TERMINAL MATERIAL | RATING | |
|-------------|-------------------------------|-----------------------|---|
| | | | |
| Q | SILVER ² | POWER | 4 AMPS @ 125 V AC or 28 V DC; 2 AMPS @ 250 V AC (UL/CSA). |
| B | GOLD ¹ | LOW LEVEL/DRY CIRCUIT | 0.4 VA MAX. @ 20 V AC or DC MAX. |

* Note: See Technical Data section of this catalog for RoHS compliant and compatible definition and specifications.

¹ CONTACTS & TERMINALS: Copper, with gold plate over nickel plate.
² CONTACTS & TERMINALS: Copper, silver plated (standard with all termination options).

NOTE: Any models supplied with Q or B contact material are RoHS compliant.

All models  with all options when ordered with 'Q' contact material.

SEAL

NONE NO SEAL

E EPOXY SEAL

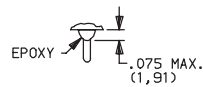

Not available on FCXX models.



K

Rotary

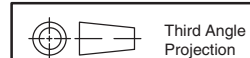

Dimensions are shown: Inch (mm)
 Specifications and dimensions subject to change

H Series Power ROTA-SLIDE® Rotary Switches

Features/Benefits

- Multi-pole and multi-position
- Positive detent
- Power switching up to 12 AMPS
- Value added capability
- RoHS Compliant

Typical Applications

- Small appliances
- Industrial equipment
- Elevators



Models Available

Specifications

CONTACT RATING: 12 Amps @ 125 V AC; 6 AMPS @ 250 V AC;
1 AMP @ 125 V DC (UL/CSA).

ELECTRICAL LIFE: 10,000 make-and-break cycles at full load.

INSULATION RESISTANCE: $10^9 \Omega$ min.

DIELECTRIC STRENGTH: 1,000 Vrms min. @ sea level.

INDEXING: 45°-one contact models, 8 positions max.; two contact models, 4 positions max.

OPERATING & STORAGE TEMPERATURE: -30°C to 95°C

Materials

HOUSING & BUSHING: 6/6 nylon (UL 94V-2).

ACTUATOR: 6/6 nylon (UL 94V-2).

CONTACTS & TERMINALS: Copper, silver plated.

CONTACT SPRING: Music wire or stainless steel.

MOUNTING NUT: Steel, zinc plated.

TERMINAL SEAL: Epoxy.

NOTE: Any models supplied with Q, B or G contact material are RoHS compliant.

NOTE: Specifications and materials listed above are for switches with standard options. For information on specific and custom switches, consult Customer Service Center.

Build-A-Switch

To order, simply select desired option from each category and place in the appropriate box. Available options are shown and described on pages K-26 thru K-27. For additional options not shown in catalog, consult Customer Service Center.

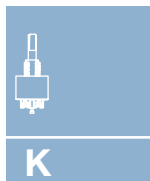
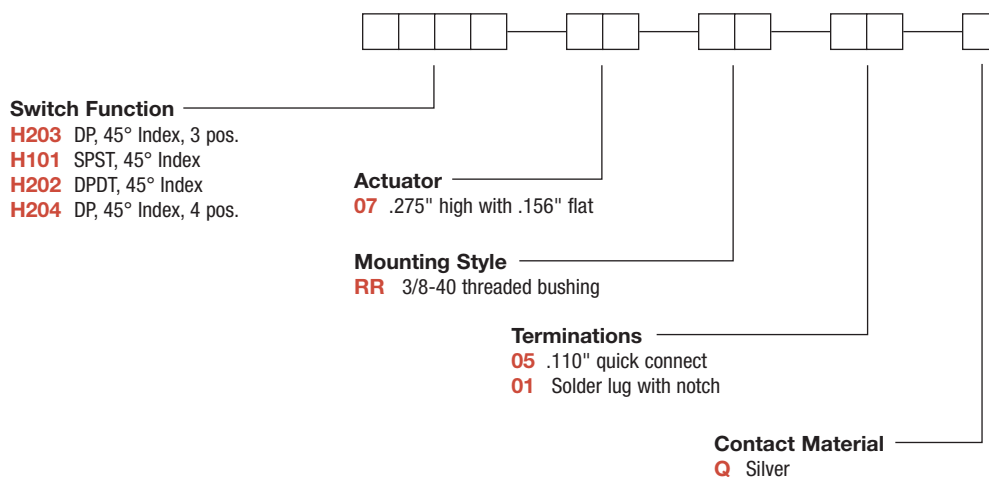

Rotary



Dimensions are shown: Inch (mm)
Specifications and dimensions subject to change

H Series Power ROTA-SLIDE® Rotary Switches

SWITCH FUNCTION

| SP MODELS 45° INDEXING | | | |
|------------------------|-------------|-----------------|-----------|
| NO. POLES | MODEL NO. | SWITCH FUNCTION | TERMINALS |
| SP | H101 | SPST | 8-1 |

| DP MODELS 45° INDEXING | | | |
|------------------------|-------------|-----------------|---------------|
| NO. POLES | MODEL NO. | SWITCH FUNCTION | TERMINALS |
| DP | H202 | DPDT | 7-8-1, 3-4-5 |
| | H203 | 3 Position | All Terminals |
| | H204 | 4 Position | All Terminals |

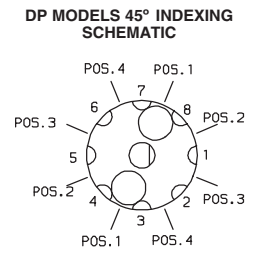
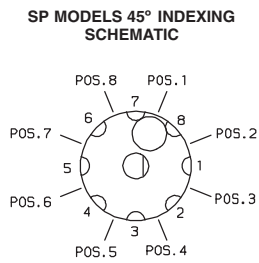

NOTE: Break-before-make contacts. Terminal numbers are molded on bottom of housing. Actuators and contacts are shown in position 1. No common terminal is present. Switching function is provided by movable contacts shorting adjacent pairs of stationary contacts.

All models  with all options.

Rotary
K

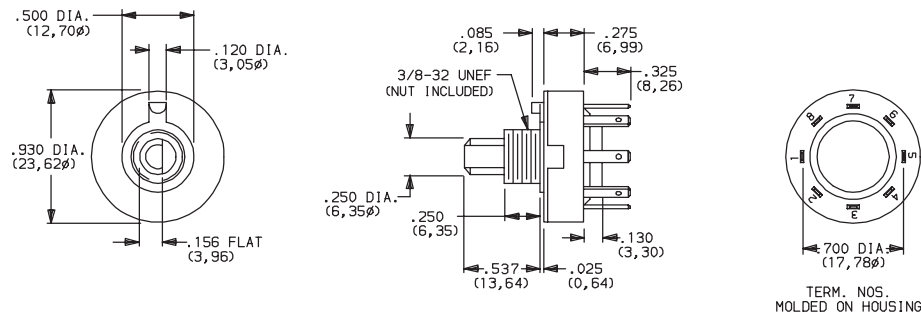

Part number shown: H10107RR05Q

ACTUATOR

07 .275" HIGH WITH .156" FLAT

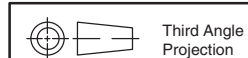
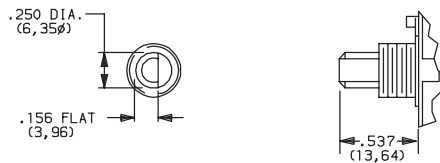

Dimensions are shown: Inch (mm)
Specifications and dimensions subject to change

H Series Power ROTA-SLIDE® Rotary Switches

MOUNTING STYLE

RR 3/8-32 THREADED BUSHING

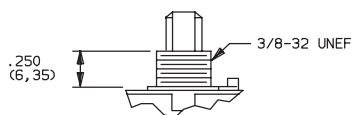

PANEL MOUNTING

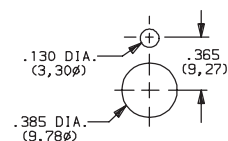

Mounting nut included (part number 925C00000).

TERMINATIONS

05 SOLDER LUG WITH HOLE

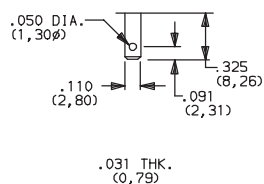

01 SOLDER LUG WITH NOTCH

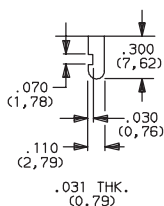

Not available on models with 90° indexing.

CONTACT MATERIAL

| OPTION CODE | CONTACT AND TERMINAL MATERIAL | RATING | |
|-------------|-------------------------------|----------|---------------------|
| | | Q | SILVER ¹ |

* Note: See Technical Data section of this catalog for RoHS compliant and compatible definition and specifications.

¹ CONTACTS & TERMINALS: Copper, silver plated.

NOTE: Any models supplied with Q contact material are RoHS compliant.

All models  with all options.



K

Rotary

C&K



Third Angle
Projection

Dimensions are shown: Inch (mm)
Specifications and dimensions subject to change

RW Series Sub-miniature Rotary Switches



Features/Benefits

- 8 and 10 positions
- SMT version
- Subminiature design

Typical Applications

- Digital cameras
- Audio & visual equipment
- Consumer electronics
- Selector dial interface

| PART NUMBER | PACKAGING |
|---------------------|---------------------|
| RW-108 NS RT | 800 pieces per reel |



Specifications

CONTACT ARRANGEMENT: 1 Pole 8 Position
 CONTACT RATING: 0.1 A @ 16 V DC.
 ELECTRICAL LIFE: 10,000 cycles.
 INITIAL CONTACT RESISTANCE: 100 mΩ max.
 INSULATION RESISTANCE: 10M Ω min.
 DIELECTRIC STRENGTH: 100V (50-60 Hz).
 TWIST FORCE: 150 ± 100 gf
 OPERATING TEMPERATURE: -20°C to 70°C

Materials

KNOB: PA (UL 94V-0).
 COVER: SUS
 HOUSING: PA (UL94V-0)
 TERMINAL: Silver plated.

NOTE: Specifications and materials listed above are for switches with standard options. For information on specific and custom switches, consult Customer Service Center.

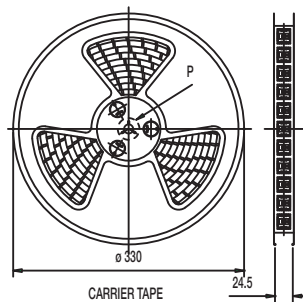
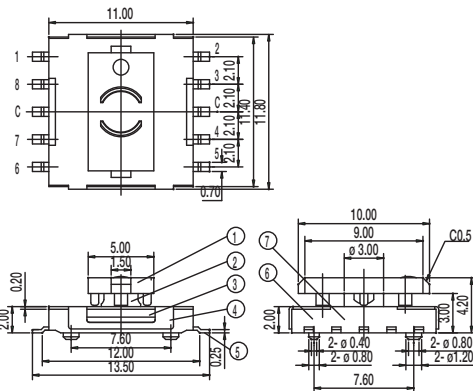

| | 0° | 45° | 90° | 135° | 180° | 225° | 270° | 315° | 360° |
|-----|-----|-----|-----|------|------|------|------|------|------|
| C-1 | ION | | | OFF | | | | | OFF |
| C-2 | OFF | ION | | | | | | | OFF |
| C-3 | OFF | | ION | | | | | | OFF |
| C-4 | OFF | | | ION | | | | | OFF |
| C-5 | OFF | | | | ION | | | | OFF |
| C-6 | OFF | | | | | ION | | | OFF |
| C-7 | OFF | | | | | | ION | | OFF |
| C-8 | OFF | | | | | | | ION | OFF |

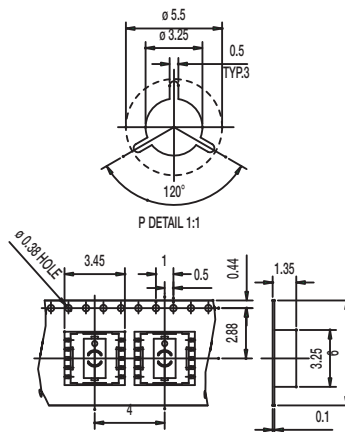
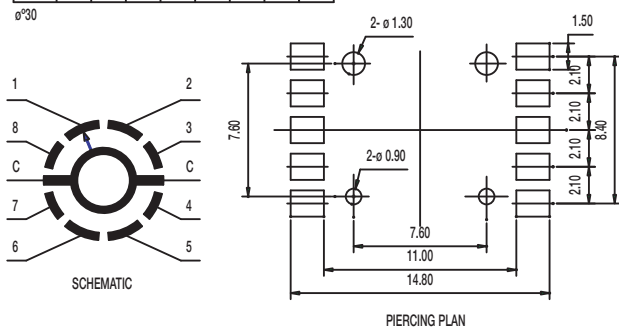

Rotary

K

RW Series Sub-miniature Rotary Switches

Specifications

CONTACT ARRANGEMENT: 1 Pole, 10 Position
 CONTACT RATING: 10 mA @ 5 V DC.
 ELECTRICAL LIFE: 7,000 cycles.
 INITIAL CONTACT RESISTANCE: 200 mΩ max.
 INSULATION RESISTANCE: 250M Ω min.
 DIELECTRIC STRENGTH: 250 VAC (50-60 Hz).
 TWIST FORCE: 90 ± 15 gf
 OPERATING TEMPERATURE: -30°C to 80°C

Materials

KNOB: PA (UL 94V-0).
 COVER: Silver plated.
 HOUSING: LCP (UL94V-0)
 TERMINAL: Silver plated.

| PART NUMBER | PACKAGING |
|----------------------|-----------------------|
| RW-1106-NS RT | 2,000 pieces per reel |



NOTE: Specifications and materials listed above are for switches with standard options. For information on specific and custom switches, consult Customer Service Center.

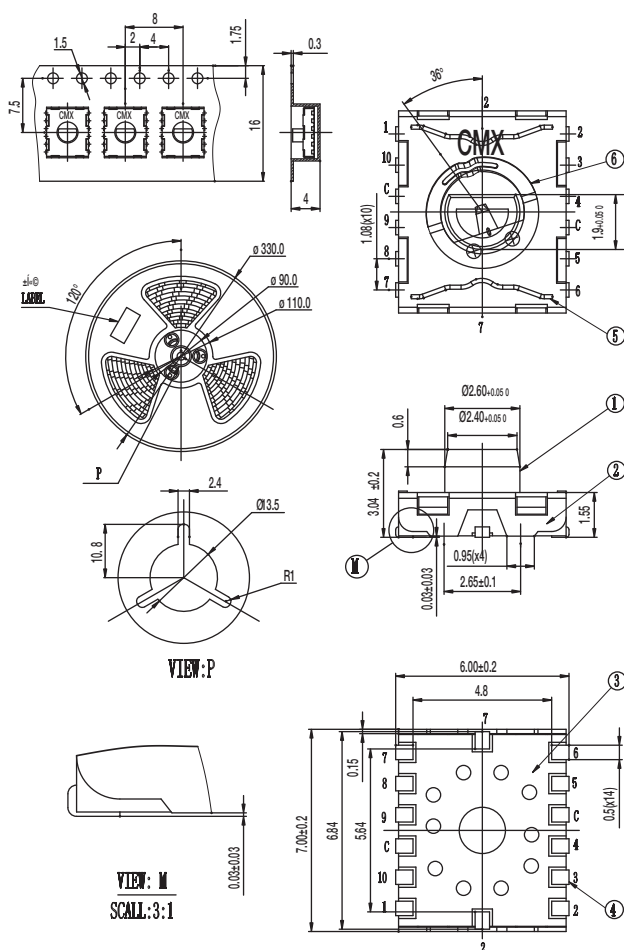

| | 0° | 36° | 72° | 108° | 144° | 180° | 216° | 252° | 288° | 324° | 360° |
|------|-----|-----|-----|------|------|------|------|------|------|------|------|
| C-1 | ON | | | | | | | | | | ON |
| C-2 | OFF | ON | | | | | | | | | OFF |
| C-3 | OFF | | ON | | | | | | | | OFF |
| C-4 | OFF | | | ON | | | | | | | OFF |
| C-5 | OFF | | | | ON | | | | | | OFF |
| C-6 | OFF | | | | | ON | | | | | OFF |
| C-7 | OFF | | | | | | ON | | | | OFF |
| C-8 | OFF | | | | | | | ON | | | OFF |
| C-9 | OFF | | | | | | | | ON | | OFF |
| C-10 | OFF | | | | | | | | | ON | OFF |

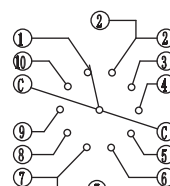

Circuit Diagram

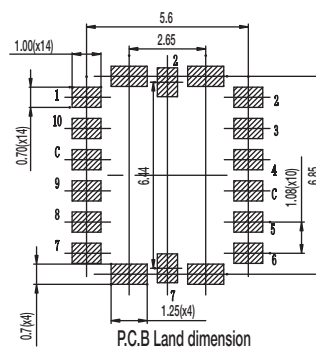

P.C.B Land dimension

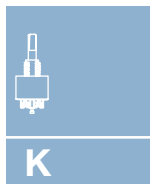

Rotary

RM Series Subminiature Rotary Switches



Features/Benefits

- Subminiature design saves space
- Screwdriver slot or extended shaft
- Positive detent
- RoHS compliant

Typical Applications

- Audio & visual equipment
- Consumer electronics
- Telecom equipment

Specifications

CONTACT RATING: 0.5A 24 V DC; 0.2A 48 V DC
 OPERATING LIFE: 2,000 cycles
 INSULATION RESISTANCE: 100 M Ω min. 500 V DC
 DIELECTRIC STRENGTH: 500 V AC for 1 minute
 OPERATING FORCE: 270 \pm 100 gf cm
 OPERATING TEMPERATURE: -40°C to 85°C

Materials

COVER: PA66
 BASE: PA6T
 ACTUATOR: PA66
 CONTACTS & TERMINALS: Brass with gold plate over nickel plate
 SPRING: Brass

NOTE: Specifications and materials listed above are for switches with standard options.
 For information on specific and custom switches, consult Customer Service Center.

Build-A-Switch

To order, simply select desired option from each category and place in the appropriate box. Available options are shown and described on pages K-30 thru K-32. For additional options not shown in catalog, consult Customer Service Center.



K

Rotary

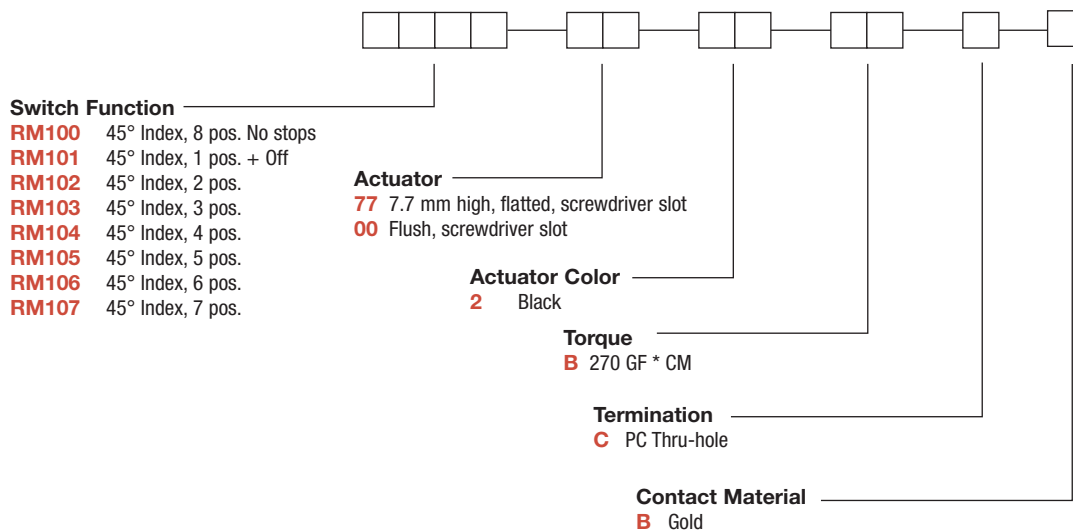

Dimensions are shown: mm
 Specifications and dimensions subject to change

RM Series Subminiature Rotary Switches

77 7.7 MM HIGH, FLATTED, SCREWDRIVER SLOT

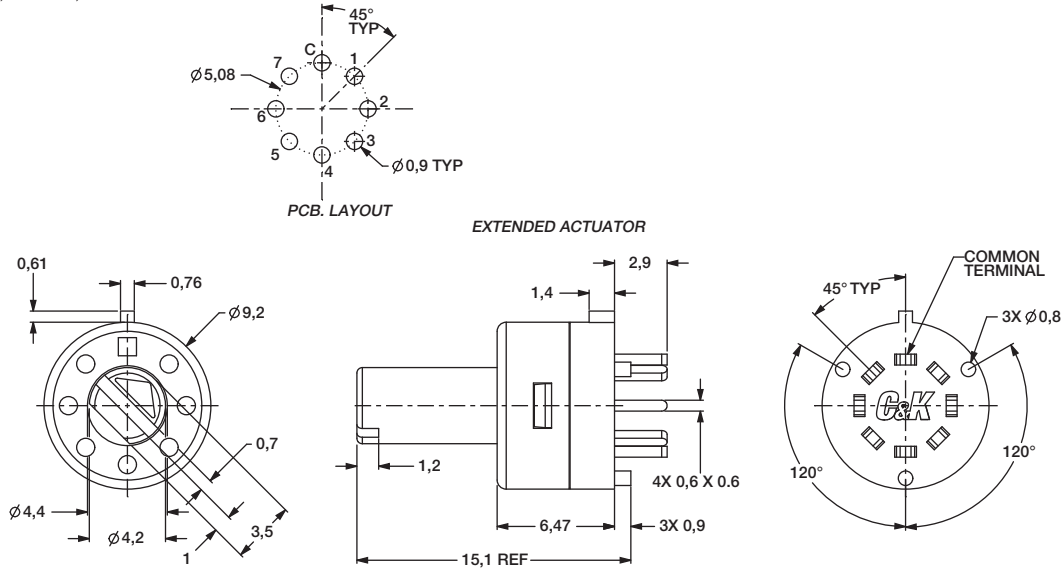

00 FLUSH, SCREWDRIVER SLOT

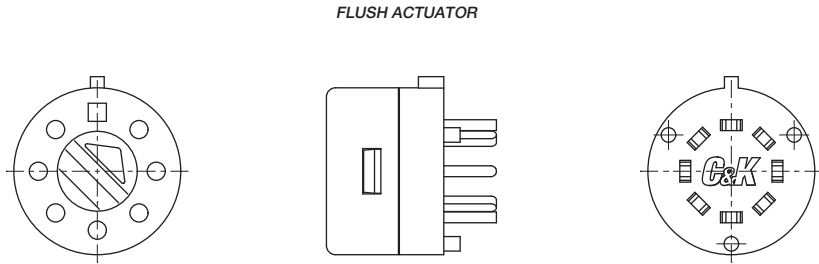

| ELECTRICAL SCHEMATIC - RM SERIES SWITCHES | | | | | | | | |
|---|--------------------|---------------------|---------------------|----------------------|----------------------|----------------------|----------------------|----------------------|
| SWITCH FUNCTION | TRAVEL POSITION 0° | TRAVEL POSITION 45° | TRAVEL POSITION 90° | TRAVEL POSITION 135° | TRAVEL POSITION 180° | TRAVEL POSITION 225° | TRAVEL POSITION 270° | TRAVEL POSITION 315° |
| RM100 | C-C(OFF) | C-1 | C-2 | C-3 | C-4 | C-5 | C-6 | C-7 |
| RM101 | C-C(OFF) | X | X | X | X | X | X | C-7 |
| RM102 | X | C-1 | C-2 | X | X | X | X | X |
| RM103 | X | C-1 | C-2 | C-3 | X | X | X | X |
| RM104 | X | C-1 | C-2 | C-3 | C-4 | X | X | X |
| RM105 | X | C-1 | C-2 | C-3 | C-4 | C-5 | X | X |
| RM106 | X | C-1 | C-2 | C-3 | C-4 | C-5 | C-6 | X |
| RM107 | X | C-1 | C-2 | C-3 | C-4 | C-5 | C-6 | C-7 |

TERMINAL ID NUMBERS ARE SHOWN FOR REFERENCE ONLY AND ARE NOT MARKED ON BOTTOM OF THE SWITCH

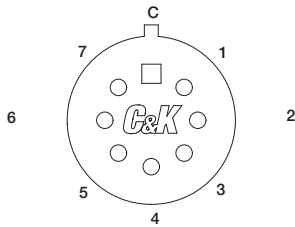

EXTERIOR KEY TAB SHOWN IDENTIFIES "C" (COMMON TERMINAL)



Dimensions are shown: mm
Specifications and dimensions subject to change

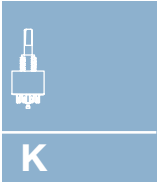

Rotary

RM Series Subminiature Rotary Switches

KNOBS

297F02000

296F02000

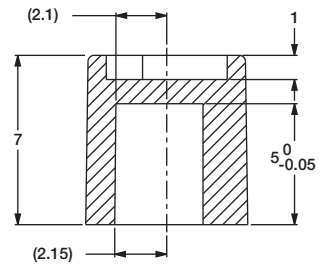
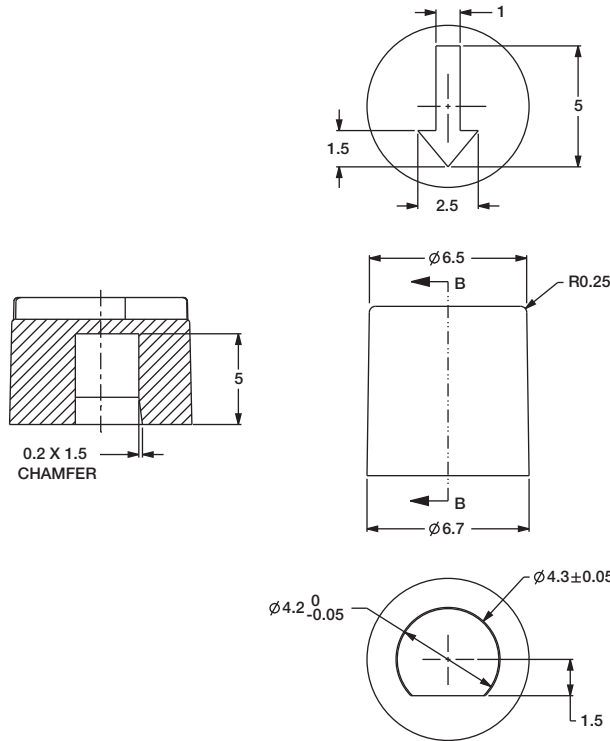
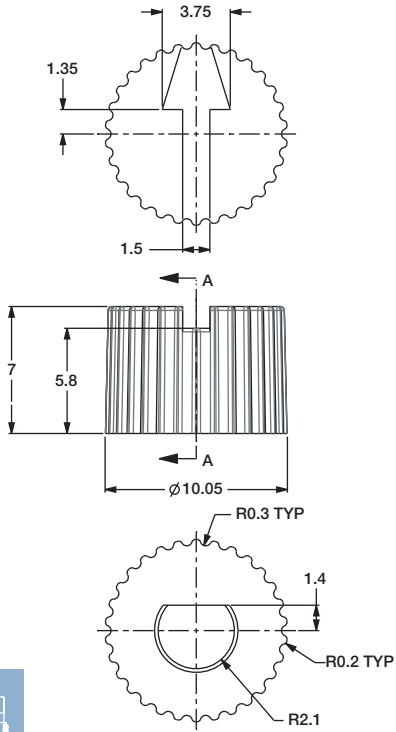

K

Rotary

ENC Series Optical Encoder



Features/Benefits

- Clear detent/haptic feel
- Two channel, 2-bit code output
- Quadrature (Incremental type)
- Integrated pushbutton
- Panel mount with screw thread
- Cable and connector termination

Typical Applications

- Automotive interior control
- Industrial equipment
- Test & Instrumentation
- Medical equipment

Specifications

ROTARY

ELECTRICAL & MECHANICAL

OPERATING VOLTAGE: DC 5 ± 0.25V, 30mA max.

OUTPUT VOLTAGE: Logic high > 3V DC
Logic low < 1V DC

ROTATIONAL TORQUE: 265 gf-cm initially

MECHANICAL LIFE: 300K cycles

PUSHBUTTON

ELECTRICAL & MECHANICAL

OPERATING VOLTAGE: DC 5V, 10mA

INITIAL CONTACT RESISTANCE: 10 ohm max.

ACTUATION FORCE: 600 ± 20% gf

SHAFT TRAVEL: 0.74 ± 0.2mm

CONTACT BOUNCE: < 4ms make, < 10ms break

MECHANICAL LIFE: 300K cycles

Environmental Data

OPERATING TEMPERATURE: -40°C to + 90°C

OPERATING RELATIVE HUMIDITY: ≤ 96% RH, +40°C

STORAGE TEMPERATURE: -40°C to +90°C

Materials

ACTUATOR: Zinc Alloy

HOUSING FRAME: Zinc Alloy

DETENT ROTOR: POM, HB

DETENT SPRING: SUS

HOUSING UPPER: PA66, V0

HOUSING LOWER: POM, HB

PUSHBUTTON DOME: SUS



K

Rotary

Build-A-Switch

Product specifications and technical information listed above are for standard offer on Optical Encoder. For special options and custom request, please contact your sales representative.

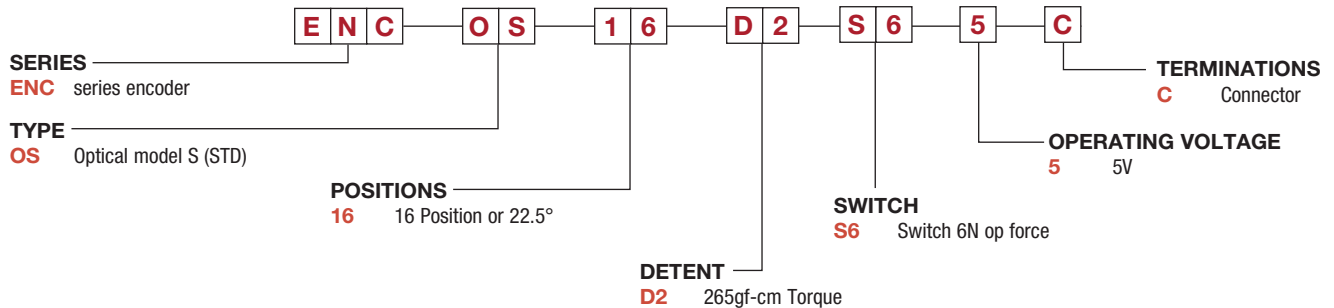

ENC Series Optical Encoder

| PART NUMBER | PACKAGING |
|----------------------|-----------|
| ENCOS16D2S65C | Tray |

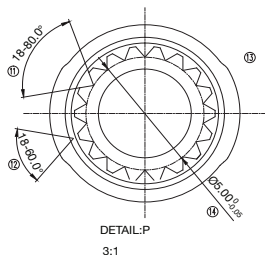
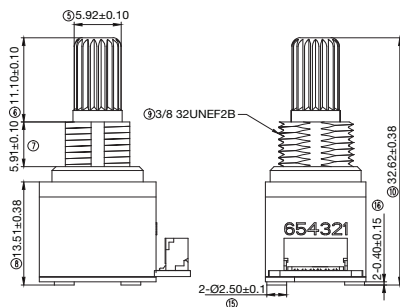
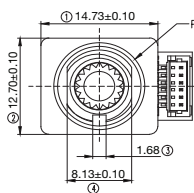

K

Rotary

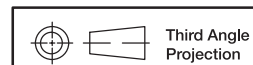





Third Angle
Projection

Dimensions are shown: mm
Specifications and dimensions subject to change

Switchlocks

Product Selection Guide

| | | | | | |
|----------------------------|---|---|--|---|---|
| Switchlock |  |  |  |  |  |
| Series | Y | YF | YM | P | PF & PM |
| Switch Type | 4,5,6 Tumbler | 4 Tumbler | 4 Tumbler | 4 Tumbler | 5 Tumbler |
| Lock | Metal | Metal | Metal | Plastic | Plastic |
| Latch Pawl | • | | | | |
| Miniature | | • | • | | • |
| Anti-static | • | | | | |
| Momentary | • | | | | |
| Poles | 1 & 2 | 1 & 2 | 1 | 1 & 2 | 1 & 2 |
| Indexing | 45° & 90° | 90° | 90° | 45° & 90° | 45° & 90° |
| Max. Current | 4 Amps | 4 Amps | 4 Amps | 4 Amps | 4 Amps |
| Panel Mount Options | | | | | |
| Snap-in | | | | • | • |
| Bushing | • | • | • | | |
| PC Thru-hole | • | | | | |
| Page No. | L-3 | L-11 | L-15 | L-18 | L-22/L-26 |

| | | | |
|----------------------------|---|--|---|
| Switchlock |  |  |  |
| Series | A | H | PL |
| Switch Type | 4 & 5 Tumbler | 4 & 6 Tumbler | 5 Tumbler |
| Lock | Metal | Metal | Plastic |
| Cam | | | • |
| Miniature | | | • |
| Anti-static | • | | |
| Momentary | | | |
| Poles | 1 - 4 | 1 & 2 | N/A |
| Indexing | 30°, 45°, 90° | 45° & 90° | 90° |
| Max. Current | 2.5 Amps | 12 Amps | |
| Panel Mount Options | | | |
| Snap-in | | | • |
| Bushing | • | • | |
| Thru-hole | • | | |
| Page No. | L-29 | L-34 | L-39 |



Dimensions are shown: Inch (mm)
Specifications and dimensions subject to change

Y Series 4, 5 & 6 Tumbler Switchlocks

Features/Benefits

- **Anti-static switch—exceeds 20 KV DC static resistance**
- **Momentary models available**
- **Wire leads and harnesses available**

Typical Applications

- **Point-of-sale terminals**
- **Cash registers**
- **Computers**

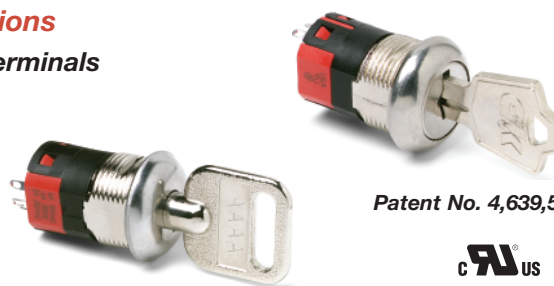

Patent No. 4,639,562

C&K
US
Models Available

Specifications

CONTACT RATING: Q contact material: 4 AMPS @ 125 V AC or 28 V DC; 2 AMPS @ 250 V AC (UL/CSA). See page L-9 for additional ratings.

ELECTRICAL LIFE: 10,000 make-and-break cycles at full load.

CONTACT RESISTANCE: Below 10 m Ω typ. initial @ 2-4 V DC, 100 mA, for both silver and gold plated contacts.

INSULATION RESISTANCE: 10⁹ Ω min.

DIELECTRIC STRENGTH: 1,000 Vrms min. @ sea level.

INDEXING: 45° or 90°, 2-4 positions (4&5 tumbler switchlocks).

45°, 3 positions; or 90°, 2 positions (6 tumbler tubular switchlocks).

Other functions available, consult Customer Service Center.

STATIC RESISTANCE: Anti-static models exceed 20 KV DC static resistance @ sea level, lock body to terminals.

MOUNTING TORQUE: 10 in./lbs.; 14 in./lbs max.

Materials

LOCK: Zinc alloy with stainless steel facing, std. (4 & 5 tumbler lock and 6 tumbler tubular lock).

KEYS: Two nickel plated brass keys, with code number, std. (4 and 5 tumbler lock). Two die cast chrome plated zinc alloy keys, std. (6 tumbler lock).

SWITCH HOUSING: Glass filled polyester (UL 94V-0).

CONTACTS AND TERMINALS: Q contact material: Copper, silver plated. See page L-9 for additional contact materials.

MOUNTING NUT: Zinc alloy.

MOUNTING CLIP: Steel, zinc plated.

DRESS NUT: Brass, nickel plated.

TERMINAL SEAL: Epoxy.

NOTE: Any models supplied with Q, B or G contact material are RoHS compliant.

NOTE: Specifications and materials listed above are for switchlocks with standard options. For information on specific and custom switchlocks, consult Customer Service Center.

Build-A-Switch

To order, simply select desired option from each category and place in the appropriate box. Available options are shown and described on pages L-4 through L-10. For additional options not shown in catalog, consult Customer Service Center.

| | | | |
|---|---|---|--|
| | | | |
| <p>Switch and Lock Function</p> <p>Y10013 SP, 45°, keypull pos. 1</p> <p>Y1011U SP, 90°, keypull pos. 1 & 2</p> <p>Y1001U SP, 45°, keypull pos. 1 & 3</p> <p>Y2001U DP, 45°, keypull pos. 1 & 3</p> <p>Y10082 SP, 45°, keypull pos. 1</p> <p>Y20082 DP, 45°, keypull pos. 1</p> <p>Y100AA SP, 45°, keypull pos. 1, 2 & 3</p> <p>Y200AA DP, 45°, keypull pos. 1, 2 & 3</p> <p>Y100AB SP, 45°, keypull pos. 1, 2, 3 & 4</p> <p>Y200AB DP, 45°, keypull pos. 1, 2, 3 & 4</p> <p>Y10113 SP, 90°, keypull pos. 1</p> <p>Y20113 DP, 90°, keypull pos. 1</p> <p>Y1011C SP, 90°, keypull pos. 2</p> <p>Y2011C DP, 90°, keypull pos. 2</p> <p>Y2011U DP, 90°, keypull pos. 1 & 2</p> <p>Y14173 SP, 90°, keypull pos. 1</p> <p>Y1417U SP, 90°, keypull pos. 1, 2 & 3</p> <p>Y10812 SP, 45°, mom., keypull pos. 1</p> <p>Y20812 DP, 45°, mom., keypull pos. 1</p> <p>Y19073 SP w/common, 90°, keypull pos. 1</p> <p>Y1907U SP w/common, 90°, keypull pos. 1, 2 & 3</p> <p>Y1900S SP w/common, 90°, keypull pos. 1, 2, 3 & 4</p> | <p>Keying</p> <p>2 Two nickel plated brass keys (4 & 5 tumbler) or two die cast zinc alloy keys with chrome plating (6 tumbler)</p> <p>6 Two nickel plated brass keys with code on lock face</p> <p>Lock Type</p> <p>A 4 Tumbler lock (YX08 models)</p> <p>C 4 Tumbler lock with detent</p> <p>V 6 Tumbler tubular lock</p> <p>B 5 Tumbler lock</p> <p>R 4 Tumbler lock with detent and anti-Static switch</p> <p>W 6 Tumbler tubular lock with anti-Static switch</p> <p>Lock Finish</p> <p>2 Stainless steel facing</p> <p>8 Gloss black facing</p> <p>F Polished nickel facing</p> | <p>Terminations</p> <p>03 Solder lug with hole</p> <p>01 Solder lug with notch</p> <p>02 PC Thru-hole</p> <p>07 Solder lug with hole (Y190XX models only)</p> <p>WC Wire lead</p> <p>Mounting/Lock Style</p> <p>N With nut</p> <p>D With clip</p> <p>L With removable dress nut and latch pawl</p> <p>R With removable dress nut</p> | <p>Contact Material</p> <p>Q Silver</p> <p>B Gold</p> <p>G Gold over silver</p> <p>Seal</p> <p>NONE No seal</p> <p>E Epoxy seal</p> |

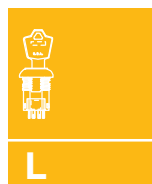

Switchlock



Dimensions are shown: Inch (mm)
Specifications and dimensions subject to change

Y Series 4, 5 & 6 Tumbler Switchlocks

SWITCH AND LOCK FUNCTION



| SINGLE & DOUBLE POLE SWITCHES | | | | | | | | | |
|---|-----------|--------------------------------|---------------------|-----------------|-----------------|-----------------|-----------------------|--------------------|-------------|
| NO. TUMBLERS | NO. POLES | MODEL NO. | CONNECTED TERMINALS | | | | KEY PULL POSITIONS | LOCK CONFIGURATION | INDEXING |
| | | | POS. 1 | POS. 2 | POS. 3 | POS. 4 | | | |
| 4, 5 & 6 | SP | Y10013 | 8-1 | 1-2 | 2-3 | | Position 1 | | |
| 4, 5 & 6 | SP DP | Y1001U Y2001U | 8-1 8-1, 4-5 | 1-2 1-2, 5-6 | 2-3 2-3, 6-7 | | Positions 1 & 3 | | |
| 4 & 5 | SP DP | Y10082 Y20082 | 8-1 8-1, 4-5 | 1-2 1-2, 5-6 | 7-8 7-8, 3-4 | | Position 1 | | 45° |
| 4 | SP DP | Y100AA Y200AA | 8-1 8-1, 4-5 | 1-2 1-2, 5-6 | 7-8 7-8, 3-4 | | Positions 1, 2 & 3 | | |
| 4 | SP DP | Y100AB Y200AB | 8-1 8-1, 4-5 | 1-2 1-2, 5-6 | 2-3 2-3, 6-7 | 3-4 3-4, 7-8 | Positions 1, 2, 3 & 4 | | |
| 4, 5 & 6 | SP DP | Y10113 Y20113 | 8-1 8-1, 4-5 | 1-3 1-3, 5-7 | | | Position 1 | | |
| 4 & 5 | SP DP | Y1011C Y2011C | 8-1 8-1, 4-5 | 1-3 1-3, 5-7 | | | Position 2 | | |
| 4, 5 & 6 | SP DP | Y1011U Y2011U | 8-1 8-1, 4-5 | 1-3 1-3, 5-7 | | | Positions 1 & 2 | | 90° |
| 4 | SP | Y14173 | 7-1 | 1-3 | 6-7 | | Position 1 | | |
| 4 | SP | Y1417U | 7-1 | 1-3 | 6-7 | | Positions 1, 2 & 3 | | |
| SINGLE & DOUBLE POLE MOMENTARY SWITCHES | | | | | | | | | |
| NO. TUMBLERS | NO. POLES | MODEL NO. | CONNECTED TERMINALS | | | | KEY PULL POSITIONS | LOCK CONFIGURATION | INDEXING |
| | | | POS. 1 | POS. 2 | POS. 3 | POS. 4 | | | |
| 4 | SP DP | Y10812 Y20812 | 8-1 8-1, 4-5 | 1-2 1-2, 5-6 | | | Position 1 | | 45° Mom. |



Switchlock

LEGEND

- ▲ = Momentary Positions (45°)
- = Detent Positions (45° or 90°)
- ⊙ = Key pull possible in these positions.
- ⊙ = Stop Positions

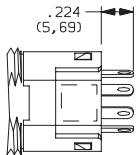

TERMINAL NUMBERS

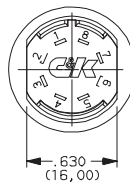

Terminal numbers molded on bottom of housing.

All models **C&K** with all options when ordered with 'G' or 'Q' contact material.



Third Angle Projection

Dimensions are shown: Inch (mm)
Specifications and dimensions subject to change



Y Series 4, 5 & 6 Tumbler Switchlocks

SWITCH AND LOCK FUNCTION



| SINGLE POLE SWITCHES WITH COMMON | | | | | | | | | |
|----------------------------------|-----------|-----------|---------------------|--------|--------|--------|-----------------------|--------------------|----------|
| NO. TUMBLERS | NO. POLES | MODEL NO. | CONNECTED TERMINALS | | | | KEY PULL POSITIONS | LOCK CONFIGURATION | INDEXING |
| | | | POS. 1 | POS. 2 | POS. 3 | POS. 4 | | | |
| 4 | SP | Y19073 | C-1 | C-2 | C-4 | | Position 1 | | 90° |
| | | Y1907U | | | | | Positions 1, 2 & 3 | | |
| | | Y1900S | C-1 | C-2 | C-3 | C-4 | Positions 1, 2, 3 & 4 | | |

LEGEND

- = Detent Positions (45° or 90°)
- ⊙ = Key pull possible in these positions.
- ⊙ = Stop Positions

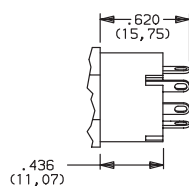

TERMINAL NUMBERS

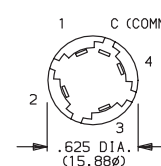

Terminal numbers marked on insulator.

All models **C&K** US with all options when ordered with 'G' or 'Q' contact material.

NOTE: Epoxy seal not available. Removable dress nut not available with any Y190XX models.

4 & 5 Tumbler

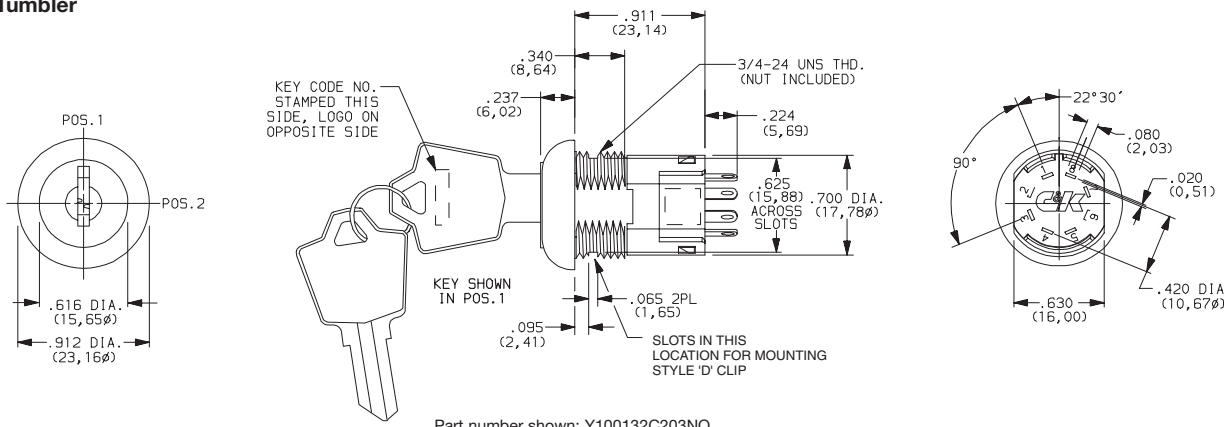

6 Tumbler

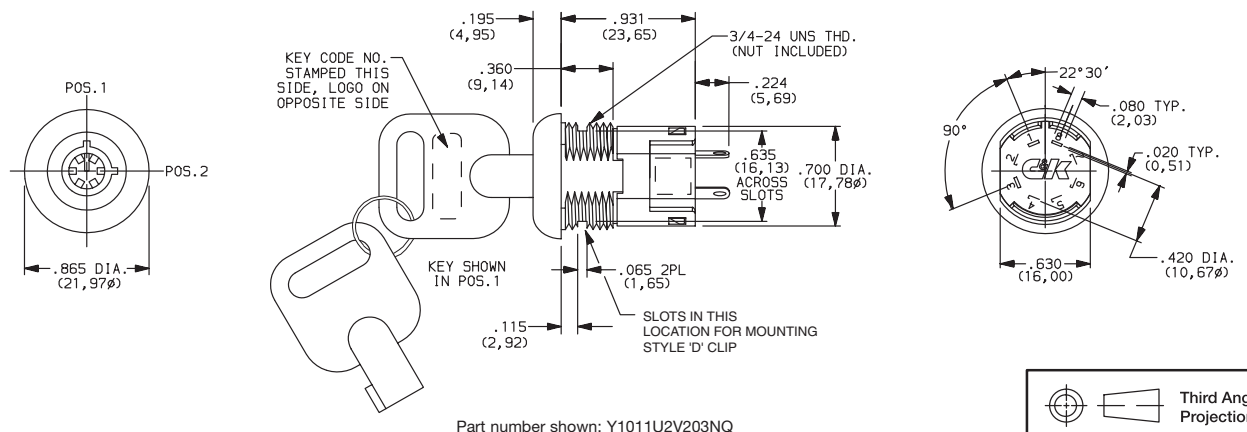

Dimensions are shown: Inch (mm)
Specifications and dimensions subject to change

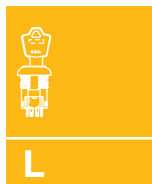

Switchlock

Y Series 4, 5 & 6 Tumbler Switchlocks

SWITCH AND LOCK FUNCTION

| AVAILABLE OPTION COMBINATIONS | | | | | | | | | | | | | | | |
|-------------------------------|------------|---|---|---|---|---|--------------|----|----|----|----|----------------------|---|---|---|
| MODELS | LOCK TYPES | | | | | | TERMINATIONS | | | | | MOUNTING/LOCK STYLES | | | |
| | A | B | C | R | V | W | 01 | 02 | 03 | 07 | WC | D | L | N | R |
| YX0013 | | • | • | | • | • | • | • | • | | • | • | | • | • |
| YX001U | | • | • | • | • | • | • | • | • | | • | • | • | • | • |
| YX0082 | | • | • | • | | | • | • | • | | • | • | | • | |
| YX00AX | | | • | • | | | • | • | • | | • | • | | • | • |
| YX0113 | | • | • | • | • | • | • | • | • | | • | • | | • | • |
| YX011C | | • | • | • | | | • | • | • | | • | • | | • | • |
| YX01IU | | • | • | • | • | • | • | • | • | | • | • | • | • | • |
| Y141XX | | | • | • | | | • | • | • | | • | • | | • | • |
| YX0812 | • | | | | | | • | • | • | | • | • | | • | |
| Y190XX | | | • | • | | | | • | | • | • | • | | • | |

KEYING

| OPTION CODE | KEYING OPTIONS | CODE NO. ON KEY | CODE NO. ON LOCK |
|-------------|--|-----------------|------------------|
| 2 | 2 NICKEL PLATED BRASS KEYS (4 & 5 TUMBLER) or 2 DIE CAST CHROME PLATED ZINC ALLOY KEYS (6 TUMBLER) | YES | NO |
| 6 | 2 NICKEL PLATED BRASS KEYS, 4 & 5 TUMBLER ONLY | YES | YES |

NOTE: All orders keyed alike, standard. For more than one key code, master keying, replacement keys, or other special features, consult Customer Service Center.

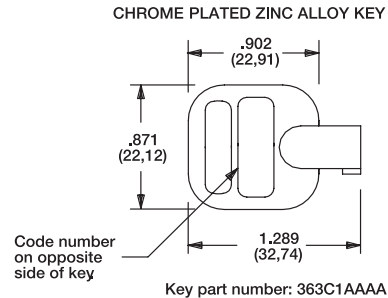
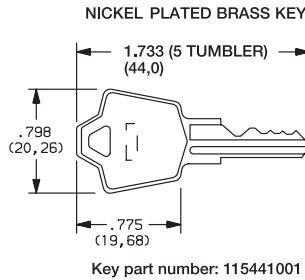
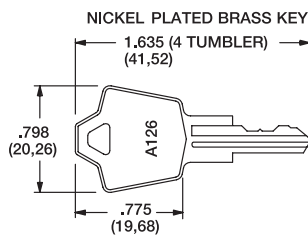

NOTE: Keys are available separately, see page L-10. Key head shape subject to change without notice.

LOCK TYPE

- C** 4 TUMBLER LOCK WITH DETENT
- B** 5 TUMBLER LOCK

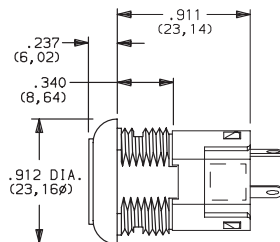

- V** 6 TUMBLER TUBULAR LOCK

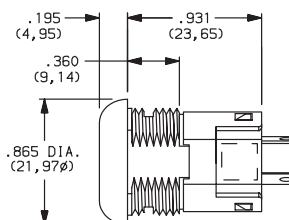

Available with Lock Finish '2' only

- A** 4 TUMBLER LOCK (MOMENTARY MODELS ONLY)

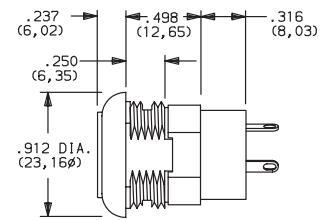

Dimensions are shown: Inch (mm)
Specifications and dimensions subject to change



Y Series 4, 5 & 6 Tumbler Switchlocks

LOCK TYPE

SHORT ANTI-STATIC LOCK TYPES

R 4 TUMBLER LOCK WITH DETENT AND SHORT ANTI-STATIC SWITCH.

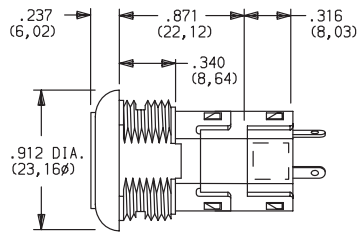

W 6 TUMBLER TUBULAR LOCK WITH ANTI-STATIC SWITCH

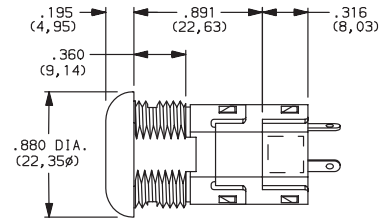

Available with Lock Finish '2' only.

NOTE: For available option combinations, see page L-9.
U.S. Pat. No. 4,639,562 Exceeds 20 KV DC static resistance @ sea level, lock body to terminals.

LOCK FINISH

2 STAINLESS STEEL

8 GLOSS BLACK

F POLISHED NICKEL



Available with Lock Types 'V' & 'W' only.

NOTE: For available option combinations, see page L-9.

TERMINATIONS

03 SOLDER LUG WITH HOLE

01 SOLDER LUG WITH NOTCH

02 PC THRU-HOLE

WC WIRE LEAD

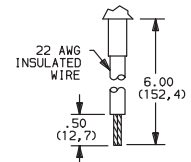
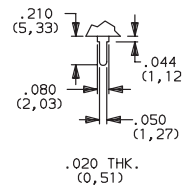
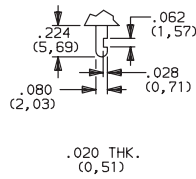
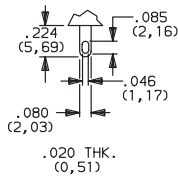

Black wire standard. other colors and lengths available, consult Customer Service Center. UL style 1015.

All Models Except Y190

02 PC THRU-HOLE

07 SOLDER LUG WITH HOLE

WC WIRE LEAD

PC MOUNTING

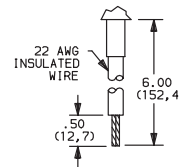
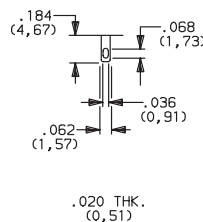
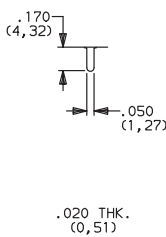

Black wire standard. other colors and lengths available, consult Customer Service Center. UL style 1015.

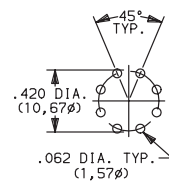

Dimensions are shown: Inch (mm)
Specifications and dimensions subject to change



Switchlock

Y Series 4, 5 & 6 Tumbler Switchlocks

MOUNTING/LOCK STYLE

N WITH NUT

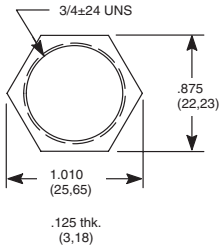

Nut part number: 937C00000

D WITH CLIP

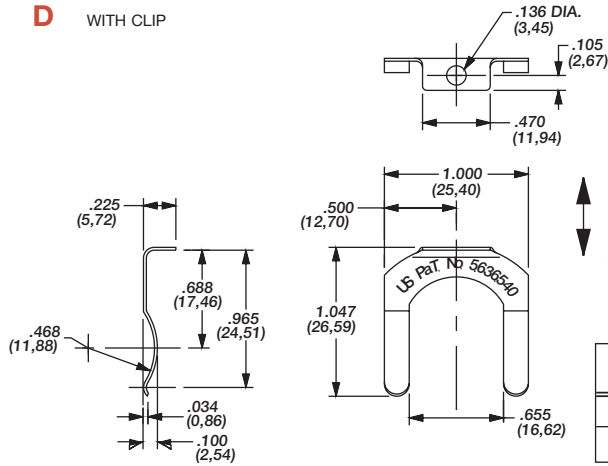

Clip part number: 906B00000

PANEL MOUNTING

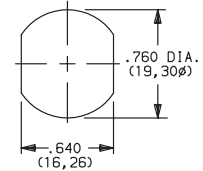

GRAIN DIRECTION
BURR SIDE UP

| OPTION CODE | MOUNTING STYLE | PANEL THICKNESS |
|-------------|----------------|-----------------------|
| N | WITH NUT | .085-.105 (2,16-2,67) |
| D | WITH CLIP | .085-.105 (2,16-2,67) |

R REMOVABLE DRESS NUT

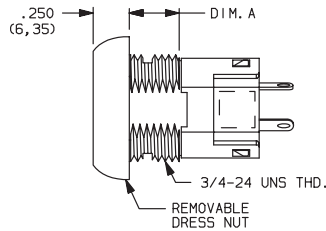
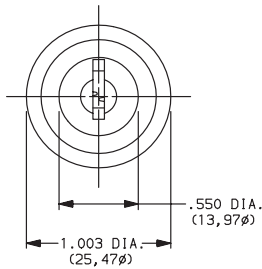

PANEL MOUNTING

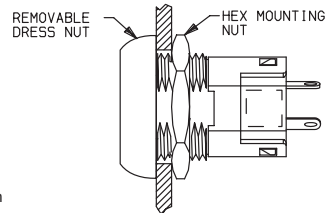
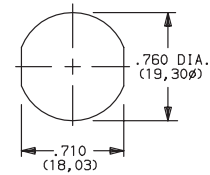

| LOCK DIMENSIONS | |
|-----------------|-------------|
| LOCK TYPES | DIMENSIONS |
| A, N | .270 (6,68) |
| C, R | .360 (9,14) |

TYPICAL INSTALLATION

Install hex nut with enough clearance to allow for dress nut and panel. Place switch through cutout in rear of panel. Install and tighten dress nut by hand, then tighten hex nut. Always tighten assembly with back of panel hex nut to avoid damaging front of panel.

NOTE: Removable dress nut not available with Y1900A or Y100AA model options.

L REMOVABLE DRESS NUT WITH LATCH PAWL

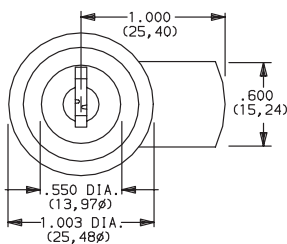

Latch pawl shown in pos. 1.

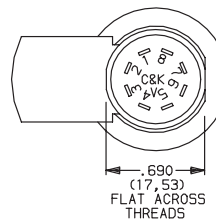
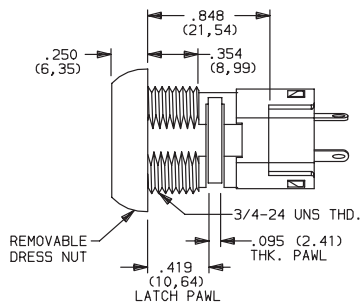

PANEL MOUNTING

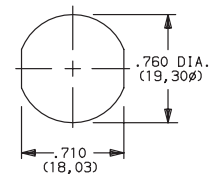

Switchlock

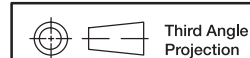

Third Angle Projection

Dimensions are shown: Inch (mm)
Specifications and dimensions subject to change



Y Series 4, 5 & 6 Tumbler Switchlocks

MOUNTING/LOCK STYLE

Mounting Information (All Models)

| PANEL THICKNESS | | | |
|-----------------|-------------------------|-------------------|-------------------------|
| MOUNTING STYLES | A, B LOCK TYPES | C, R LOCK TYPES | V, W LOCK TYPES |
| D | .065-.085 (1, 65-2, 16) | | .085-.105 (2, 16-2, 67) |
| N | .105 (2, 67) max. | .195 (4, 95) max. | .215 (5, 46) max. |
| L | .215 (5, 46) max. | | - |
| R | .125 (3, 18) max. | .215 (5, 46) max. | - |

| AVAILABLE OPTION COMBINATIONS | | | | | | | | | |
|-------------------------------|---------------|---|---|------------|---|---|---|---|---|
| MOUNTING STYLES | LOCK FINISHES | | | LOCK TYPES | | | | | |
| | 2 | 8 | F | A | B | C | R | V | W |
| D | ● | ● | ● | ● | ● | ● | ● | ● | ● |
| N | ● | ● | ● | ● | ● | ● | ● | ● | ● |
| R | | ● | ● | ● | | ● | ● | | |
| L | | ● | ● | | | ● | ● | | |

CONTACT MATERIAL

| OPTION CODE | RoHS COMPLIANT* | RoHS COMPATIBLE* | CONTACT AND TERMINAL MATERIAL | RATING | |
|-------------|-----------------|------------------|-------------------------------|--------------------------------|--|
| Q | YES | YES | SILVER ² | POWER | 4 AMPS @ 125 V AC or 28 V DC; 2 AMPS @ 250 AC V AC (UL/CSA). |
| B | YES | YES | GOLD ¹ | LOW LEVEL/DRY CIRCUIT | 0.4 VA MAX. @ 20 V AC or DC MAX |
| G | YES | YES | GOLD SILVER ³ | LOW LEVEL/DRY CIRCUIT OR POWER | 0.4 VA MAX. @ 20 V AC or DC MAX. or 4 AMPS @ 125 V AC or 28 V DC; 2 AMPS @ 250 V AC (UL/CSA) |

* Note: See Technical Data section of this catalog for RoHS compliant and compatible definitions and specifications.

- ¹ CONTACTS & TERMINALS: Copper, with gold plate over nickel plate.
² CONTACTS & TERMINALS: Copper, silver plated (std. with all termination options).
³ CONTACTS & TERMINALS: Copper, with gold plate over silver plate.

All models  with all options when ordered with 'G' or 'Q' contact material.

SEAL

NONE NO SEAL

E EPOXY SEAL

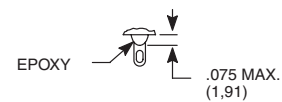

Dimensions are shown: Inch (mm)
Specifications and dimensions subject to change



Y Series 4, 5 & 6 Tumbler Switchlocks

AVAILABLE HARDWARE



Key Code: A126
4 TUMBLER
PART NO. (ONE KEY)
115140126
Material: Brass
Finish: Nickel plate

Key Code: D001
5 TUMBLER
PART NO. (ONE KEY)
115441001
Material: Brass
Finish: Nickel plate



Key Code: AAAA
PART NO. (ONE KEY)
363C1AAAA

Material: Zinc alloy
Finish: Chrome plate



Switchlock



Dimensions are shown: Inch (mm)
Specifications and dimensions subject to change

YF Series 4 Tumbler Miniature Switchlocks

Features/Benefits

- Multi-pole and multi-position
- Positive detent
- Low level and power capability

Typical Applications

- Computer servers
- Point-of-sale terminals
- Cash registers



Models Available

Specifications

CONTACT RATING: Q contact material: 4 AMPS @ 125 V AC or 28 V DC; 2 AMPS @ 250 V AC (UL/CSA). See page L-14 for additional ratings.

ELECTRICAL LIFE: 10,000 make-and-break cycles at full load.

CONTACT RESISTANCE: Below 10 m Ω typ. initial @ 2-4 V DC, 100 mA, for both silver and gold plated contacts.

INSULATION RESISTANCE: 10⁹ Ω min.

DIELECTRIC STRENGTH: 1,000 Vrms min. @ sea level.

INDEXING: 90°:2 positions max.

Materials

LOCK: Zinc alloy with stainless steel facing. 4 tumbler, single bitted lock with integral detent mechanism.

KEYS: Two nickel plated brass keys with code number.

SWITCH HOUSING: 6/6 Nylon (UL 94V-2).

CONTACTS & TERMINALS: Q contact material: Copper, silver plated. See page L-14 for additional contact materials.

MOUNTING NUT: Brass, bright zinc plated.

TERMINAL SEAL: Epoxy.

NOTE: Any models supplied with Q or B contact material are RoHS compliant.

NOTE: Specifications and materials listed above are for switchlocks with standard options. For information on specific and custom switchlocks, consult Customer Service Center.

Build-A-Switch

To order, simply select desired option from each category and place in the appropriate box. Available options are shown and described on pages L-12 through L-14. For additional options not shown in catalog, consult Customer Service Center.

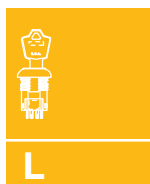
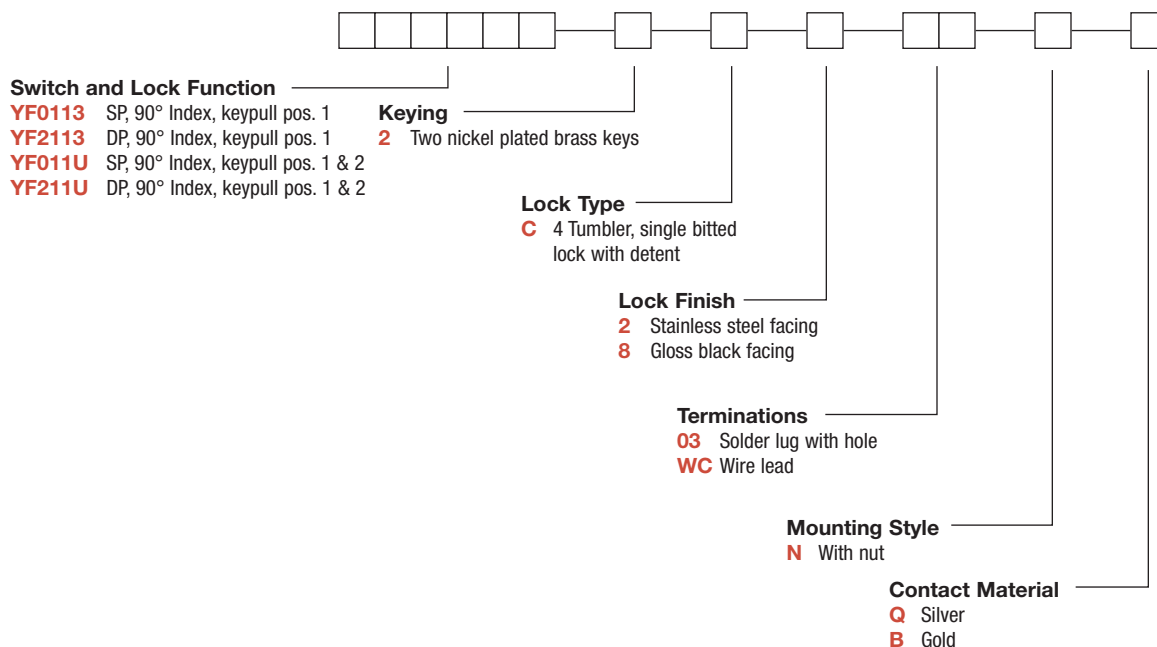

Switchlock



Dimensions are shown: Inch (mm)
Specifications and dimensions subject to change

YF Series 4 Tumbler Miniature Switchlocks

SWITCH AND LOCK FUNCTION

| SINGLE & DOUBLE POLE SWITCHES | | | | | | | |
|-------------------------------|------------------|---------------------|----------|--------|--------------------|--------------------|----------|
| NO. POLES | MODEL NO. | CONNECTED TERMINALS | | | KEY PULL POSITIONS | LOCK CONFIGURATION | INDEXING |
| | | POS. 1 | POS. 2 | POS. 3 | | | |
| SP DP | YF0113 YF2113 | 8-1 | 1-3 | | Position 1 | | 90° |
| | | 8-1, 4-5 | 1-3, 5-7 | | | | |
| SP DP | YF011U YF211U | 8-1 | 1-3 | | Positions 1 & 2 | | |
| | | 8-1, 4-5 | 1-3, 5-7 | | | | |

TERMINAL NUMBERS

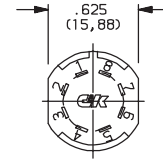

Terminal numbers molded on bottom of housing.

All models with all options when ordered with 'Q' contact material.

LEGEND

- = Detent Positions (45° or 90°)
- ⊙ = Key pull possible in these positions.
- ⊙ = Stop Positions

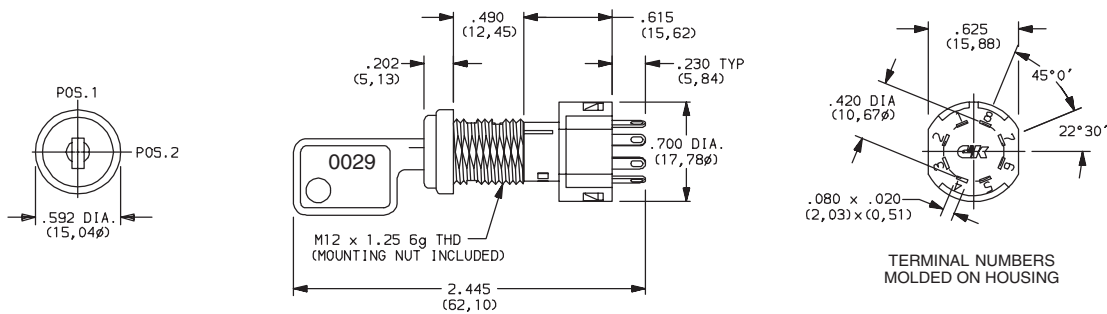

Part number shown: YF01132C203NQ



Switchlock

KEYING

2 TWO NICKEL PLATED BRASS KEYS

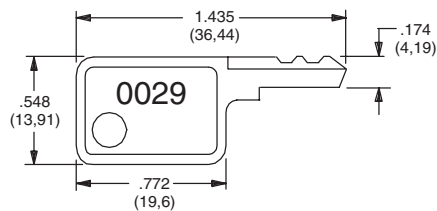

Key Part Number: 960B10029

NOTE: All orders keyed alike with code number on key. For more than one key code, replacement keys, or other special features, consult Customer Service Center.



Dimensions are shown: Inch (mm)
Specifications and dimensions subject to change



YF Series 4 Tumbler Miniature Switchlocks

LOCK TYPE

C 4 TUMBLER, SINGLE BITTED LOCK WITH DETENT

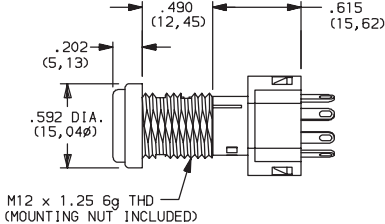

LOCK FINISH

2 STAINLESS STEEL FACING

8 GLOSS BLACK FACING



TERMINATIONS

03 SOLDER LUG WITH HOLE

WC WIRE LEAD

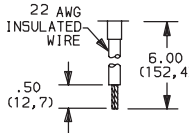
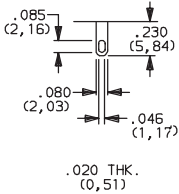

Black wire standard, other colors and lengths available, consult Customer Service Center. UL style 1015.

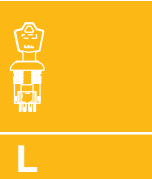

Switchlock

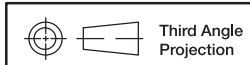

Third Angle Projection

Dimensions are shown: Inch (mm)
Specifications and dimensions subject to change

www.ck-components.com

YF Series 4 Tumbler Miniature Switchlocks

MOUNTING STYLE

N WITH NUT

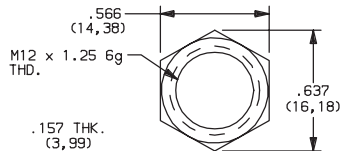

Nut part number: 1790901A47

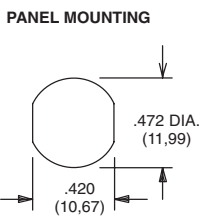

Panel thickness:
.300 (7,62) max.

Switch and Lock Assembly Instructions

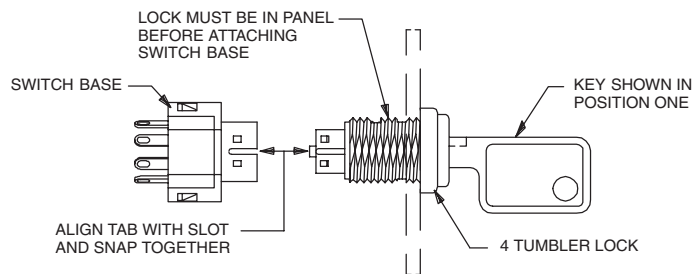

NOTE: Switch installation is permanent. Switch cannot be removed from lock after assembly. Attempts to separate switch and lock may damage switch.

CONTACT MATERIAL

| OPTION CODE | RoHS COMPLIANT* | RoHS COMPATIBLE* | CONTACT AND TERMINAL MATERIAL | RATING | |
|-------------|-----------------|------------------|-------------------------------|-----------------------|---|
| | | | | | |
| Q | YES | YES | SILVER ² | POWER | 4 AMPS @ 125 V AC or 28 V DC; 2 AMPS @ 250 V AC (UL/CSA). |
| B | YES | YES | GOLD ¹ | LOW LEVEL/DRY CIRCUIT | 0.4 VA MAX. @ 20 V AC or DC MAX. |

* Note: See Technical Data section of this catalog for RoHS compliant and compatible definitions and specifications.

¹ CONTACTS & TERMINALS: Copper, with gold plate over nickel plate.

² CONTACTS & TERMINALS: Copper, silver plated (standard with all termination options).

All models with all options when ordered with 'Q' contact material.

AVAILABLE HARDWARE



Switchlock



Key Code: 0029

PART NO. (ONE KEY)

960B10029

Material: Brass
Finish: Nickel plate



Third Angle Projection

Dimensions are shown: Inch (mm)
Specifications and dimensions subject to change

C&K

YM Series 4 Tumbler Miniature Switchlocks

Features/Benefits

- Snap-together assembly allows for pre-wiring of switch
- Wire lead terminations available
- 4 Tumbler lock with positive detent

Typical Applications

- Cable TV connectors
- Automotive accessories
- Computers



Models Available

Specifications

CONTACT RATING: Q contact material: 4 AMPS @ 125 V AC or 28 V DC; 2 AMPS @ 250 V AC (UL/CSA). 4 AMPS @ 125 V AC, 2 AMPS @ 250 V AC, T65, class 1 (VDE). See page L-17 for additional ratings.

ELECTRICAL LIFE: 10,000 make-and-break cycles at full load.

CONTACT RESISTANCE: Below 10 m Ω typ. initial @ 2-4 V DC, 100 mA.

INSULATION RESISTANCE: 10⁹ Ω min.

DIELECTRIC STRENGTH: 1,000 Vrms min. @ sea level.

INDEXING: 90°:2 positions.

Materials

LOCK: Zinc alloy with stainless steel facing. 4 tumbler single bitted lock with integral detent mechanism.

KEYS: Two nickel plated brass keys with code number.

SWITCH HOUSING: 6/6 Nylon (UL 94V-2).

CONTACTS & TERMINALS: Q contact material: Copper, silver plated. See page L-17 for additional contact materials.

MOUNTING NUT: Brass, bright zinc plated.

NOTE: Any models supplied with Q or B contact material are RoHS compliant.

NOTE: Specifications and materials listed above are for switchlocks with standard options. For information on specific and custom switchlocks, consult Customer Service Center.

Build-A-Switch

To order, simply select desired option from each category and place in the appropriate box. Available options are shown and described on pages L-16 and L-17. For additional options not shown in catalog, consult Customer Service Center.

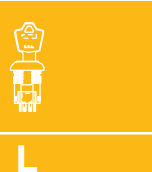
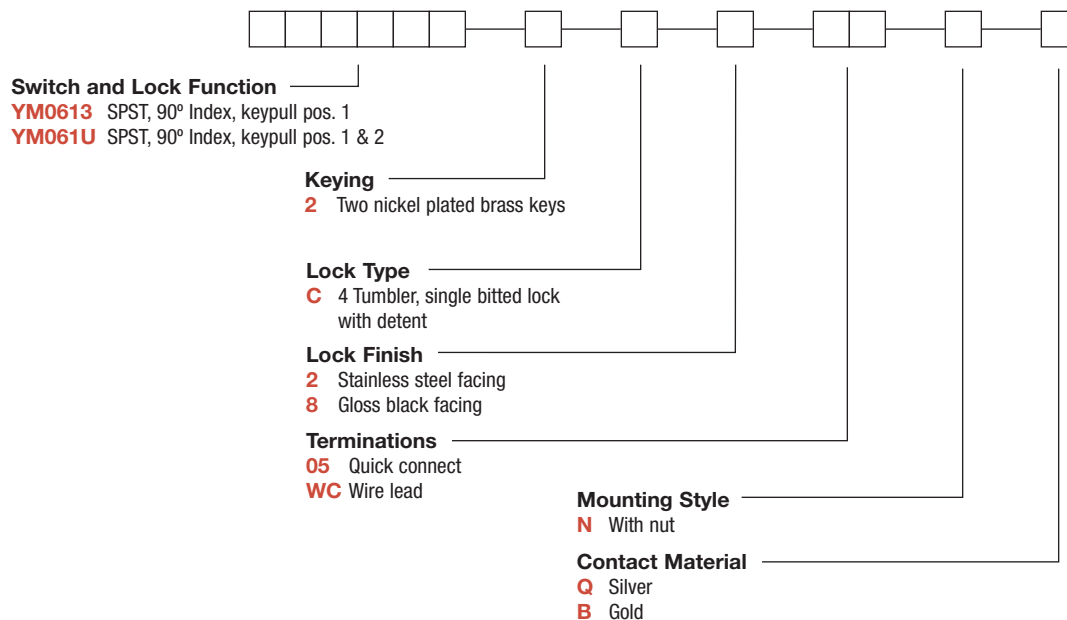

Switchlock



Dimensions are shown: Inch (mm)
Specifications and dimensions subject to change

YM Series 4 Tumbler Miniature Switchlocks

SWITCH AND LOCK FUNCTION

| NO. POLES | MODEL NO. | SWITCH FUNCTION | | KEY PULL POSITIONS | LOCK CONFIGURATION | INDEXING | SCHEMATIC |
|-------------|-----------|-----------------|--------|--------------------|--------------------|----------|-----------|
| | | POS. 1 | POS. 2 | | | | |
| SP | YM0613 | OFF | ON | Position 1 | | 90° | |
| | YM061U | | | Positions 1 & 2 | | | |
| SPST | | | | | | | |

All models with all options when ordered with 'Q' contact material.

LEGEND

- = Detent Positions (90°)
- ⊙ = Key pull possible in these positions
- ⊙ = Stop Positions

KEYING

- 2** TWO NICKEL PLATED BRASS KEYS

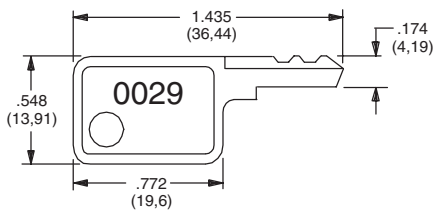

Key part number: 960B10029

NOTE: All orders keyed alike with code number on key. For more than one key code, replacement keys, or other special features, consult Customer Service Center.

LOCK TYPE

- C** 4 TUMBLER SINGLE BITTED LOCK WITH DETENT

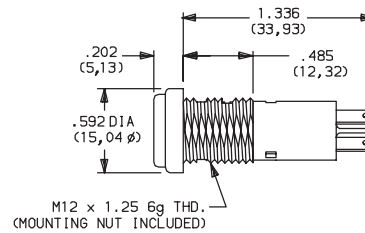

LOCK FINISH

- 2** STAINLESS STEEL FACING

- 8** GLOSS BLACK FACING



Third Angle
Projection

Dimensions are shown: Inch (mm)
Specifications and dimensions subject to change

C&K

YM Series 4 Tumbler Miniature Switchlocks

TERMINATIONS

05 QUICK CONNECT

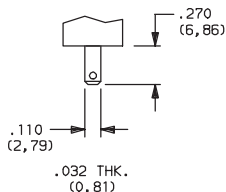

WC WIRE LEAD

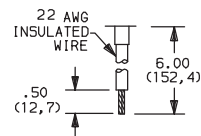

Black wire standard, other colors and lengths available, consult Customer Service Center. UL style 1015.

MOUNTING STYLE

N WITH NUT

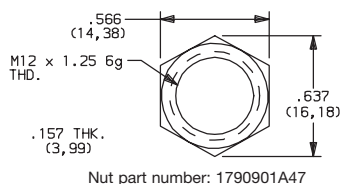

Nut part number: 1790901A47

PANEL MOUNTING

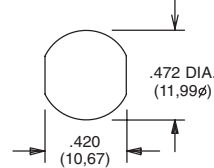

Panel thickness: .300 (7,62) max.

CONTACT MATERIAL

| OPTION CODE | RoHS COMPLIANT* | RoHS COMPATIBLE* | CONTACT AND TERMINAL MATERIAL | RATING | |
|-------------|-----------------|------------------|-------------------------------|-----------------------|--|
| | | | | POWER | 4 AMPS @ 125 V AC or 28 V DC; 2 AMPS @ 250 AC V AC (UL/CSA). |
| Q | YES | YES | SILVER ² | LOW LEVEL/DRY CIRCUIT | 0.4 VA MAX. @ 20 V AC or DC MAX. |
| B | YES | YES | GOLD ¹ | | |

* Note: See Technical Data section of this catalog for RoHS compliant and compatible definitions and specifications.

¹ CONTACTS & TERMINALS: Copper, with gold plate over nickel plate.

² CONTACTS & TERMINALS: Copper, silver plated (standard with all termination options).

All models  with all options when ordered with 'Q' contact material.

AVAILABLE HARDWARE



Key Code: 0029

PART NO. (ONE KEY)

960B10029

Material: Brass
Finish: Nickel plate



Third Angle Projection

Dimensions are shown: Inch (mm)
Specifications and dimensions subject to change

www.ck-components.com



Switchlock

P Series 4 Tumbler Snap-in Switchlocks



Models Available

Features/Benefits

- Snap-in mounting
- Multi-pole and multi-position
- Positive detent

Typical Applications

- Computers
- Communication equipment

Specifications

CONTACT RATING: Q contact material: 4 AMPS @ 125 V AC;
1 AMP @ 250 V AC (UL) See page L-20 for additional ratings.
ELECTRICAL LIFE: 10,000 make-and-break cycles at full load.
CONTACT RESISTANCE: Below 10 m Ω typ. initial @
2-4 V DC, 100 mA for both silver and gold plated contacts.
INSULATION RESISTANCE: 10⁹ Ω min.
DIELECTRIC STRENGTH: 1,000 Vrms min. @ sea level.
INDEXING: 45° or 90°, 2-3 positions.

Materials

SWITCH HOUSING & LOCK: One piece construction,
6/6 Nylon (UL 94V-2), black
4 disc tumbler mechanism.
KEYS: One nickel plated brass key and one key with insert
molded plastic head.
TUMBLERS: Disc tumblers, brass.
CONTACTS & TERMINALS: Q contact material: Copper, silver
plated. See page L-20 for additional contact materials.

NOTE: Any models supplied with Q or B contact material are RoHS compliant.

NOTE: Specifications and materials listed above are for switchlocks with standard options. For information on specific and custom switchlocks, consult Customer Service Center.

Build-A-Switch

To order, simply select desired option from each category and place in the appropriate box. Available options are shown and described on pages L-19 and L-21. For additional options not shown in catalog, consult Customer Service Center.

Switch and Lock Function

- P10113** SP, 90° Index, keypull pos. 1
- P20113** DP, 90° Index, keypull pos. 1 & 2
- P100AF** SP, 45° Index, keypull pos. 1, 2 & 3
- P200AF** DP, 45° Index, keypull pos. 1, 2 & 3
- P1011U** SP, 90° Index, keypull pos. 1 & 2

Keying

- 2** Two nickel plated brass keys
- T** One nickel plated brass key with insert molded plastic square head and one nickel plated brass key

Lock Type

- C** 4 tumbler lock with detent

Lock Finish

- M** Plastic lock with matte finish

Terminations

- 03** Solder lug
- WC** Wire lead

Contact Material

- Q** Silver
- G** Gold over silver

Lock Color

- 2** Black

Key Color

- 2** Black
- NONE** Nickel plated brass



Switchlock



Dimensions are shown: Inch (mm)
Specifications and dimensions subject to change

P Series 4 Tumbler Snap-in Switchlocks

SWITCH AND LOCK FUNCTION

| NO. POLES | MODEL NO. | CONNECTED TERMINALS | | | KEY PULL POSITIONS | LOCK CONFIGURATION | INDEXING |
|-----------|--------------------------------|---------------------|-----------------|-----------------|--------------------|--------------------|----------|
| | | POS. 1 | POS. 2 | POS. 3 | | | |
| SP DP | P10113 P20113 | 8-1 8-1, 4-5 | 1-3 1-3, 5-7 | | Position 1 | | 90° |
| DP | P100AF P200AF | 8-1 8-1, 4-5 | 1-2 1-2, 5-6 | 2-3 2-3, 6-7 | Positions 1, 2 & 3 | | 45° |
| SP | P1011U | 8-1 | 1-3 | | Positions 1 & 2 | | 90° |

TERMINAL NUMBERS

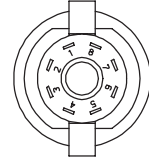

Terminal numbers molded on housing.

All models with all options when ordered with 'Q' contact material.

LEGEND

- = Detent Positions (45° or 90°)
- ⊙ = Key pull possible in these positions.
- = Stop Positions

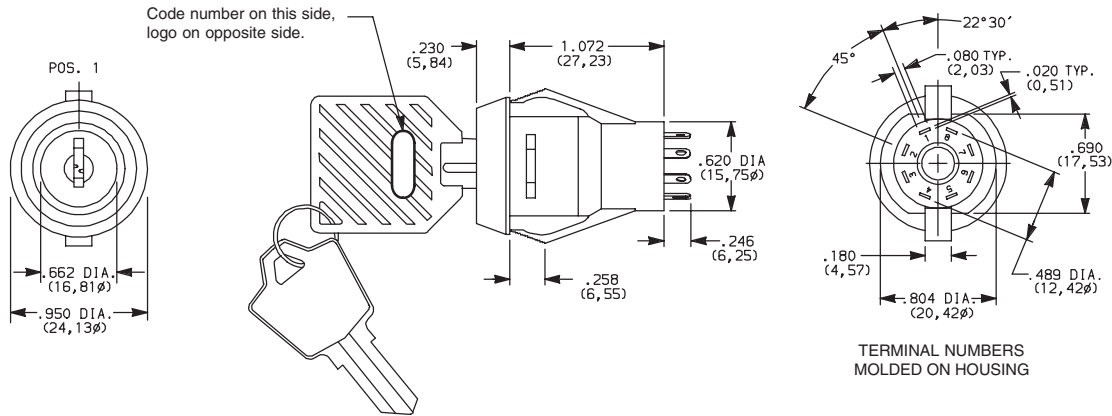

TERMINAL NUMBERS
MOLDED ON HOUSING

Part number shown: P100AFTCM03Q22

KEYING

| OPTION CODE | KEYING OPTIONS | CODE NO. ON KEY | CODE NO. ON LOCK |
|-------------|--|-----------------|------------------|
| 2 | 2 NICKEL PLATED BRASS KEYS | YES | NO |
| T | 1 NICKEL PLATED BRASS KEYS, WITH PLASTIC INSERT MOLDED SQUARE HEAD & 1 NICKEL PLATED BRASS KEY | YES | NO |

NICKEL PLATED BRASS KEY

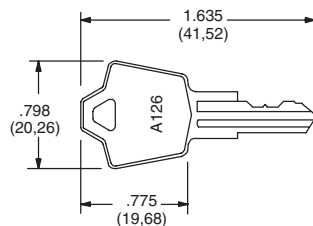

Key part number: 115140126

NICKEL PLATED BRASS KEY WITH PLASTIC INSERT MOLDED SQUARE HEAD

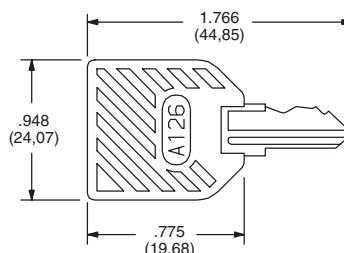

Key part number: 11599112602

NOTE: All orders keyed alike with code number on key. For more than one key code, replacement keys, or other special features, consult Customer Service Center.

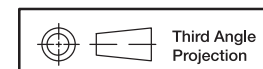

Third Angle
Projection

Dimensions are shown: Inch (mm)
Specifications and dimensions subject to change



P Series 4 Tumbler Snap-in Switchlocks

LOCK TYPE

C 4 TUMBLER LOCK WITH DETENT

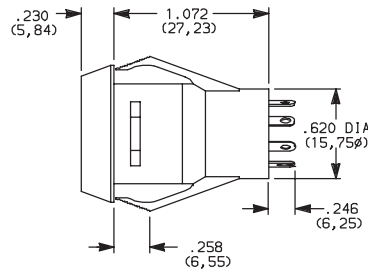

| OPTION CODE | LOCK COLOR |
|-------------|------------|
| 2 | BLACK |

LOCK FINISH

M PLASTIC LOCK WITH MATTE FINISH

TERMINATIONS

03 SOLDER LUG

WC WIRE LEAD

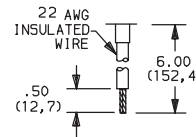
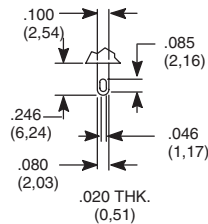

Black wire standard, other colors and lengths available, consult Customer Service Center. UL style 1015.

PC MOUNTING

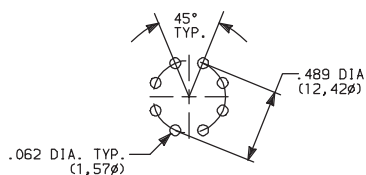

PANEL MOUNTING

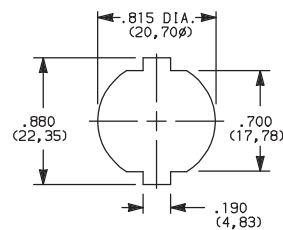

Panel Thickness: .100-.200 (2,54-5,08)

CONTACT MATERIAL

| OPTION CODE | RoHS COMPLIANT* | RoHS COMPATIBLE* | CONTACT AND TERMINAL MATERIAL | RATING | |
|-------------|-----------------|------------------|-------------------------------|--------------------------------|--|
| | | | | POWER | 4 AMPS @ 125 V AC; 1 AMP @ 250 V AC (UL/CSA) |
| Q | YES | YES | SILVER ² | LOW LEVEL/DRY CIRCUIT OR POWER | 0.4 VA MAX. @ 20 V AC or DC MAX. or 4 AMPS @ 125 V AC; 1 AMP @ 250 V AC (UL/CSA) |
| G | YES | YES | GOLD OVER SILVER ³ | | |

* Note: See Technical Data section of this catalog for RoHS compliant and compatible definitions and specifications.

² CONTACTS & TERMINALS: Copper, silver plated (standard with all termination options)
³ CONTACTS & TERMINALS: Copper, with gold plate over silver plate termination

All models **C&K** with all options when ordered with 'Q' contact material.



Third Angle Projection

Dimensions are shown: Inch (mm)
 Specifications and dimensions subject to change



P Series 4 Tumbler Snap-in Switchlocks

AVAILABLE HARDWARE



Key Code: A126
4 TUMBLER
PART NO. (ONE KEY)
115140126
Material: Brass
Finish: Nickel plate

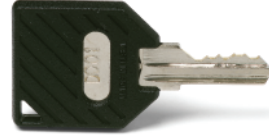

Key Code: A126
4 TUMBLER
PART NO. (ONE KEY)
1159112602 BLACK
Material: Brass
Finish: Nickel plate
6/6 Nylon insert molded head



Switchlock

PF Series 5 Tumbler Miniature Snap-in Switchlocks



Features/Benefits

- Snap-in mounting
- Multi-pole and multi-position
- Positive detent

Typical Applications

- Computers
- Point-of-sale terminals
- Instrumentation



Models Available

Specifications

CONTACT RATING: Q contact material: 4 AMPS @ 125 V AC or 28 V DC; 2 AMPS @ 250 V AC (UL/CSA). See page L-25 for additional ratings.

ELECTRICAL LIFE: 10,000 make-and-break cycles at full load.

CONTACT RESISTANCE: Below 10 m Ω typ. initial @ 2-4 V DC, 100 mA, for both silver and gold plated contacts.

INSULATION RESISTANCE: 10⁹ Ω min.

DIELECTRIC STRENGTH: 1,000 Vrms min. @ sea level.

INDEXING: 45°: 3 positions, 90°:2 positions.

Materials

LOCK: 6/6 nylon with matte finish (UL 94V-2), black,

5 tumbler, single bitted lock with integral detent mechanism.

KEYS: Two nickel plated brass keys with black plastic head.

SWITCH HOUSING: 6/6 nylon (UL 94V-2).

CONTACTS & TERMINALS: Q contact material: Copper, silver plated. See page L-25 for additional contact materials.

TERMINAL SEAL: Epoxy.

NOTE: Any models supplied with Q or B contact material are RoHS compliant.

NOTE: Specifications and materials listed above are for switchlocks with standard options. For information on specific and custom switchlocks, consult Customer Service Center.

Build-A-Switch

To order, simply select desired option from each category and place in the appropriate box. Available options are shown and described on pages L-23 through L-25. For additional options not shown in catalog, consult Customer Service Center.

Switch and lock Function

PF011U SP, 90° Index, keypull pos. 1 & 2

PF201U DP, 45° Index, keypull pos. 1 & 3

PF211U DP, 90° Index, keypull pos. 1 & 2

Keying

E Two nickel plated brass keys with insert molded plastic head

Lock Type

B 5 Tumbler lock with detent

Lock Finish

M Plastic lock with matte finish

Terminations

03 Solder lug with hole

WC Wire lead

Lock Style

K Cone shaped facing

Contact Material

Q Silver

B Gold

Lock Color

2 Black

Key Color

2 Black



Dimensions are shown: Inch (mm)

Specifications and dimensions subject to change



PF Series 5 Tumbler Miniature Snap-in Switchlocks

SWITCH AND LOCK FUNCTION



| SINGLE & DOUBLE POLE SWITCHES | | | | | | | |
|-------------------------------|--------------------------------|---------------------|-----------------|----------|--------------------|--------------------|----------|
| NO. POLES | MODEL NO. | CONNECTED TERMINALS | | | KEY PULL POSITIONS | LOCK CONFIGURATION | INDEXING |
| | | POS. 1 | POS. 2 | POS. 3 | | | |
| DP | PF201U | 8-1, 4-5 | 1-2, 5-6 | 2-3, 6-7 | Positions 1 & 3 | | 45° |
| SP DP | PF011U PF211U | 8-1 8-1, 4-5 | 1-3 1-3, 5-7 | | Positions 1 & 2 | | 90° |

All models with all options when ordered with 'Q' contact material.

LEGEND

- = Detent Positions (45° or 90°)
- ⊙ = Key pull possible in these positions.
- = Stop Positions

TERMINAL NUMBERS

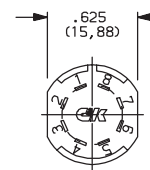

Terminal numbers molded on housing.

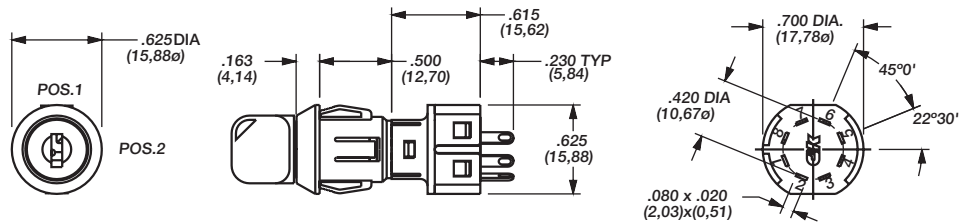

Part number shown: PF011UEBM03KQ22

KEYING



KEY COLOR

E TWO NICKEL PLATED BRASS KEYS WITH INSERT MOLDED PLASTIC HEAD

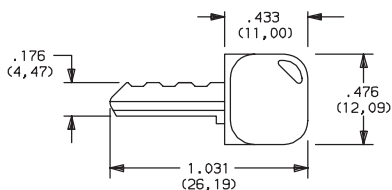

Key part number: 617D1004102

| OPTION CODE | KEY COLOR |
|-------------|-----------|
| 2 | BLACK |

NOTE: All orders keyed alike, standard. For more than one key code, replacement keys, or other special features, consult Customer Service Center.



Third Angle Projection

Dimensions are shown: Inch (mm)
Specifications and dimensions subject to change



Switchlock

PF Series 5 Tumbler Miniature Snap-in Switchlocks

LOCK TYPE  LOCK COLOR 

B 5 TUMBLER LOCK WITH DETENT

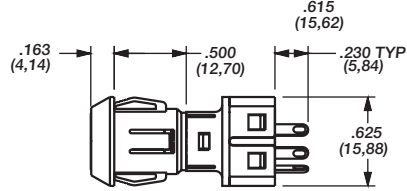

| OPTION CODE | LOCK COLOR |
|-------------|------------|
| 2 | BLACK |

LOCK FINISH 

M PLASTIC LOCK WITH MATTE FINISH



TERMINATIONS 

03 SOLDER LUG WITH HOLE

WC WIRE LEAD

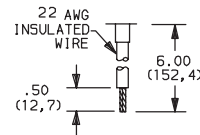
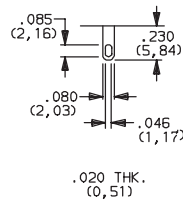

Black wire standard, other colors and lengths available, consult Customer Service Center. UL style 1015.

LOCK STYLE 

K CONE SHAPED FACING

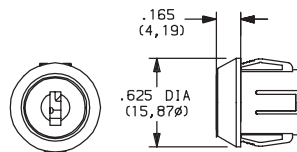

Switchlock

Switch and Lock Assembly Instructions

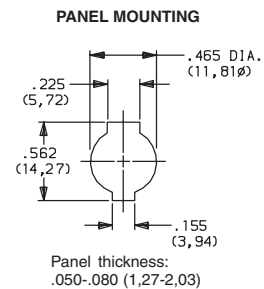
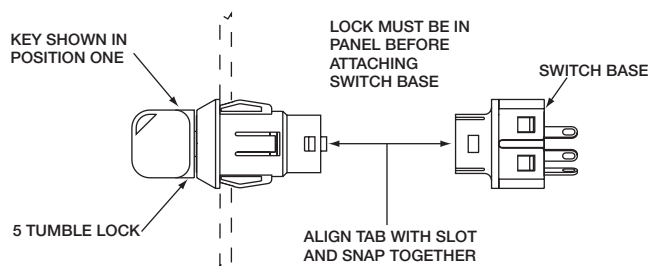

NOTE: Switch installation is permanent. Switch cannot be removed from lock after assembly. Attempts to separate switch and lock may damage switch.

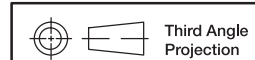

Dimensions are shown: Inch (mm)
Specifications and dimensions subject to change



PF Series 5 Tumbler Miniature Snap-in Switchlocks

CONTACT MATERIAL

| OPTION CODE | RoHS COMPLIANT* | RoHS COMPATIBLE* | CONTACT AND TERMINAL MATERIAL | RATING | |
|-------------|-----------------|------------------|-------------------------------|-----------------------|---|
| | | | | | |
| Q | YES | YES | SILVER ² | POWER | 4 AMPS @ 125 V AC or 28 V DC; 2 AMPS @ 250 V AC (UL/CSA). |
| B | YES | YES | GOLD ¹ | LOW LEVEL/DRY CIRCUIT | 0.4 VA MAX. @ 20 V AC or DC MAX. |

* Note: See Technical Data section of this catalog for RoHS compliant and compatible definitions and specifications.

¹ CONTACTS & TERMINALS: Copper, with gold plate over nickel plate.

² CONTACTS & TERMINALS: Copper, silver plated (standard with all termination options).

All models  with all options when ordered with 'Q' contact material.

AVAILABLE HARDWARE



Key Code: 041

PART NO. (ONE KEY)

617D1004102 BLACK

Material: Brass
Finish: Nickel plate
6/6 Nylon insert molded head



Switchlock



Dimensions are shown: Inch (mm)
Specifications and dimensions subject to change

PM Series 5 Tumbler Miniature Snap-in Switchlocks



Models Available

Features/Benefits

- International agency listings
- Snap-in mounting
- Wire lead terminations available
- 5 Tumbler lock with positive detent

Typical Applications

- Computers
- Point-of-sale terminals
- Marine equipment

Specifications

CONTACT RATING: Q contact material: 4 AMPS @ 125 V AC or 28 V DC; 2 AMPS @ 250 V AC (UL/CSA); 4 AMPS @ 125 V AC, 2 AMPS @ 250 V AC, T65 (VDE). See page L-28 for additional ratings.

ELECTRICAL LIFE: 10,000 make-and-break cycles at full load.

CONTACT RESISTANCE: Below 10 m Ω typ. initial @ 2-4 V DC, 100 mA, for both silver and gold plated contacts.

INSULATION RESISTANCE: 10⁹ Ω min.

DIELECTRIC STRENGTH: 1,000 Vrms min. @ sea level.

INDEXING: 90°:2 positions.

Materials

LOCK: 6/6 nylon with matte finish (UL 94V-2), color black, 5 tumbler, single bitted lock with integral detent mechanism.

KEYS: Two nickel plated brass keys with black plastic head, other colors available.

SWITCH HOUSING: 6/6 nylon (UL 94V-2).

CONTACTS & TERMINALS: Q contact material: Copper, silver plated. See page L-28 for additional contact materials.

NOTE: Any models supplied with Q or B contact material are RoHS compliant.

NOTE: Specifications and materials listed above are for switchlocks with standard options. For information on specific and custom switchlocks, consult Customer Service Center.

Build-A-Switch

To order, simply select desired option from each category and place in the appropriate box. Available options are shown and described on pages L-27 and L-28. For additional options not shown in catalog, consult Customer Service Center.

Switch and lock Function

PM0613 SP, 90°, Index, keypull pos. 1

PM061U SP, 90° Index, keypull pos. 1 & 3

Keying

E Two nickel plated brass keys with insert molded plastic head

Lock Type

B 5 Tumbler lock with detent

Lock Finish

M Plastic lock with matte finish

Terminations

05 Quick connect

WC Wire lead

Lock Style

K Cone shaped facing

Contact Material

Q Silver

B Gold

Lock Color

2 Black

Key Color

2 Black

Switchlock



Dimensions are shown: Inch (mm)
Specifications and dimensions subject to change

PM Series 5 Tumbler Miniature Snap-in Switchlocks

SWITCH AND LOCK FUNCTION



| NO. POLES | MODEL NO. | SWITCH FUNCTION | | KEY PULL POSITIONS | LOCK CONFIGURATION | INDEXING |
|--|-----------|-----------------|--------|--------------------|--------------------|----------|
| | | POS. 1 | POS. 2 | | | |
| SP | PM0613 | OFF | ON | Position 1 | | 90° |
| | PM061U | | | Positions 1 & 2 | | |
| SP <p>Part number shown: PM0613EBM05KQ22</p> | | | | | | |

All models with all options when ordered with 'Q' contact material.

LEGEND

- = Detent Position (90°)
- ⊙ = Key pull possible in these positions.
- ⦿ = Stop Positions

KEYING

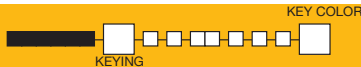

E TWO NICKEL PLATED BRASS KEYS WITH INSERT MOLDED PLASTIC HEAD

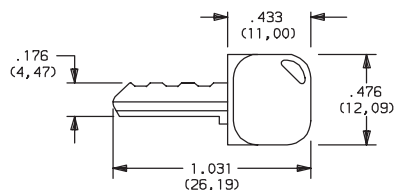

Key part number: 617D1004102

| OPTION CODE | KEY COLOR |
|-------------|-----------|
| 2 | BLACK |

NOTE: Molded plastic head color is black, standard. For more than one key code, replacement keys, or other special features, consult Customer Service Center.

LOCK TYPE

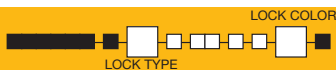

B 5 TUMBLER LOCK WITH DETENT

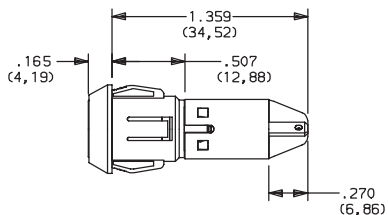

| OPTION CODE | LOCK COLOR |
|-------------|------------|
| 2 | BLACK |



Dimensions are shown: Inch (mm)
Specifications and dimensions subject to change



Switchlock

PM Series 5 Tumbler Miniature Snap-in Switchlocks

LOCK FINISH

M PLASTIC LOCK WITH MATTE FINISH



TERMINATIONS

05 QUICK CONNECT

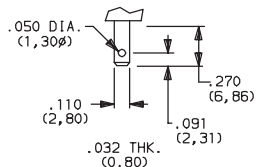

WC WIRE LEAD

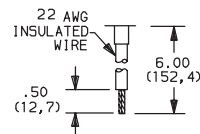

UL style 1015.
Black wire standard, other colors and lengths available, consult Customer Service Center.

LOCK STYLE

K CONE SHAPED FACING

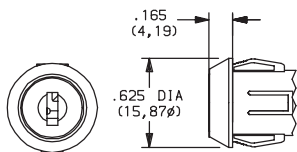

PANEL MOUNTING

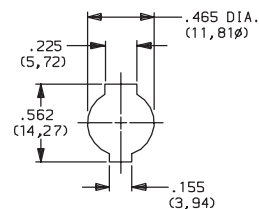

Panel thickness:
.050-.080 (1,27-2,03)

CONTACT MATERIAL

| OPTION CODE | RoHS COMPLIANT* | RoHS COMPATIBLE* | CONTACT AND TERMINAL MATERIAL | RATING | |
|-------------|-----------------|------------------|-------------------------------|-----------------------|--|
| | | | | | |
| Q | YES | YES | SILVER ² | POWER | 4 AMPS @ 125 V AC or 28 V DC; 2 AMPS @ 250 V AC (UL/CSA). 4 AMPS @ 125 V AC; or 2 AMPS @ 250 V AC; T65 (VDE). |
| B | YES | YES | GOLD ¹ | LOW LEVEL/DRY CIRCUIT | 0.4 VA MAX. @ 20 V AC or DC MAX. |

* Note: See Technical Data section of this catalog for RoHS compliant and compatible definitions and specifications.

¹ CONTACTS & TERMINALS: Copper, with gold plate over nickel plate.

All models



with all options when ordered with 'Q' contact material.

² CONTACTS & TERMINALS: Copper, silver plated (standard with all termination options).

Switchlock

AVAILABLE HARDWARE



Key Code: 041

PART NO. (ONE KEY)

617D1004102 BLACK

Material: Brass
Finish: Nickel plate
6/6 Nylon insert molded head



Dimensions are shown: Inch (mm)
Specifications and dimensions subject to change



A Series 4 & 5 Tumbler 1-4 Pole Switchlocks

Features/Benefits

- Multi-pole and multi-position
- Shorting and non-shorting contacts available
- Low level and power capability
- PCB mounting

Typical Applications

- Security alarm systems
- Medical equipment
- Computer servers



Models Available

Specifications

CONTACT RATING: Q contact material: Switch-2.5 AMPS @ 125 V AC; 350 mA @ 125 V DC (UL/CSA). Carry-5 AMPS continuous. See page L-33 for additional ratings.

ELECTRICAL LIFE: 15,000 make-and-break cycles at full load up to 300,000 detent operations.

CONTACT RESISTANCE: Below 20 m Ω typ. initial @ 2-4 V DC, 100 mA, for both silver and gold plated contacts.

INSULATION RESISTANCE: 10⁹ Ω min.

DIELECTRIC STRENGTH: 1,000 Vrms min. @ sea level.

OPERATING TEMPERATURE: -30°C to 85°C.

INDEXING: 30°: 2-4 positions, 45° or 90°: 2-3 positions.

STATIC RESISTANCE: Anti-static models exceed 20 KV DC static resistance @ sea level, lock body to terminals.

Materials

LOCK: Zinc alloy with stainless steel facing.

KEYS: Two nickel plated brass keys with code number.

SWITCH HOUSING: Glass filled 6/6 nylon (UL 94V-0).

MOVABLE CONTACT: Q contact material: Coin silver, silver plated. See page L-38 for additional contact materials.

STATIONARY CONTACTS & TERMINALS: Q contact material: Brass, silver plated. See page L-33 for additional contact materials.

MOUNTING NUT: Zinc alloy.

DRESS NUT: Brass, nickel plated.

TERMINAL SEAL: Epoxy.

NOTE: Any models supplied with Q or B contact material are RoHS compliant.

NOTE: Specifications and materials listed above are for switchlocks with standard options. For information on specific and custom switchlocks, consult Customer Service Center.

Build-A-Switch

To order, simply select desired option from each category and place in the appropriate box. Available options are shown and described on pages L-30 through L-33. For additional options not shown in catalog, consult Customer Service Center.

| | | | | | | | | |
|--|---|--|--|---|--|---|--|--|
| <p>Switch and lock Function</p> <p>A21613 DP, 30°, keypull pos. 1</p> <p>A11413 SP, 90°, keypull pos. 1</p> <p>A31413 3P, 90°, keypull pos. 1</p> <p>A3141U 3P, 90°, keypull pos. 1 & 2</p> <p>A11513 SP, 45°, keypull pos. 1</p> <p>A31513 3P, 45°, keypull pos. 1</p> <p>A3151U 3P, 45°, keypull pos. 1 & 3</p> <p>A21582 DP, 45°, keypull pos. 1</p> <p>A11613 SP, 30°, keypull p05. 1</p> <p>A1161U SP, 30°, keypull pos. 1 & 4</p> <p>A12112 SP, 45°, keypull p05. 1</p> <p>A42112 4P, 45°, keypull pos. 1</p> | <p>Keying</p> <p>2 Two nickel plated brass keys</p> | <p>Lock Type</p> <p>A 4 Tumbler lock</p> <p>G 5 Tumbler lock with anti-static switch</p> <p>Y 4 Tumbler lock with anti-static switch</p> | <p>Lock Finish</p> <p>2 Stainless steel facing</p> <p>1 Nickel plated with removable dress nut</p> <p>8 Gloss black facing</p> | <p>Shorting/Non-Shorting</p> <p>N Non-shorting contacts</p> <p>S Shorting contacts</p> | <p>Terminations</p> <p>Z Solder lug</p> <p>C PC Thru-hole</p> | <p>Mounting/Lock Style</p> <p>N With nut</p> <p>R With removable dress nut</p> | <p>Contact Material</p> <p>Q Silver</p> <p>B Gold</p> | <p>Seal</p> <p>NONE No seal</p> <p>E Epoxy seal</p> |
|--|---|--|--|---|--|---|--|--|

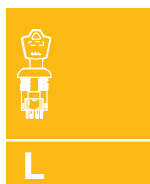

Switchlock



Dimensions are shown: Inch (mm)
Specifications and dimensions subject to change

A Series 4 & 5 Tumbler 1-4 Pole Switchlocks

SWITCH AND LOCK FUNCTION

| NO. POLES | MODEL NO. | CONNECTED TERMINALS | | | | KEY PULL POSITIONS | LOCK CONFIGURATION | INDEXING |
|-----------|----------------------------------|----------------------------|----------------------------|-----------------------|------------------|--------------------|--------------------|----------|
| | | POS. 1 | POS. 2 | POS. 3 | POS. 4 | | | |
| SP 3P | A11413 * A31413 | A-1 A-1, B-5, C-9 | A-4 A-4, B-8, C-12 | | | Position 1 | | 90° |
| 3P | A3141U | A-1, B-5, C-9 | A-4, B-8, C-12 | | | Positions 1 & 2 | | |
| SP 3P | A11513 * A31513 | A-1 A-1, B-5, C-9 | A-2 A-2, B-6, C-10 | A-4 A-4, B-8, C-12 | | Position 1 | | 45° |
| 3P | A3151U | A-1, B-5, C-9 | A-2, B-6, C-10 | A-4, B-8, C-12 | | Positions 1 & 3 | | |
| DP | A21582 | A-4, C-10 | A-5, C-11 | A-2, C-8 | | Position 1 | | |
| SP DP | A11613 * A21613 | A-1 A-1, C-7 | A-2 A-2, C-8 | A-3 A-3, C-9 | A-4 A-4, C-10 | Position 1 | | 30° |
| SP | A1161U * | A-1 | A-2 | A-3 | A-4 | Positions 1 & 4 | | |
| SP 4P | A12112 * A42112 | A-1 A-1, B-4, C-7, D-10 | A-2 A-2, B-5, C-8, D-11 | | | Position 1 | | 45° |

LEGEND

- = Detent Positions (30°, 45° or 90°)
- ⊙ = Key pull possible in these positions.
- = Stop Positions

TERMINAL NUMBERS



4P MODEL



3P MODEL

***NOTE:** Switchlock models A114XX, A115XX, A116XX and A12112 with 'C' terminations have additional terminal no. 8 as switch support only. This terminal is not connected electrically inside switch.

All models **C&K** **US** with all options when ordered with 'Q' contact material.
AX14 models not available with 'S' shorting contacts.

SP MODEL (omit terminals B, C & D)
DP MODEL (omit terminals B & D)

Terminal numbers molded on housing bottom.

Switchlock

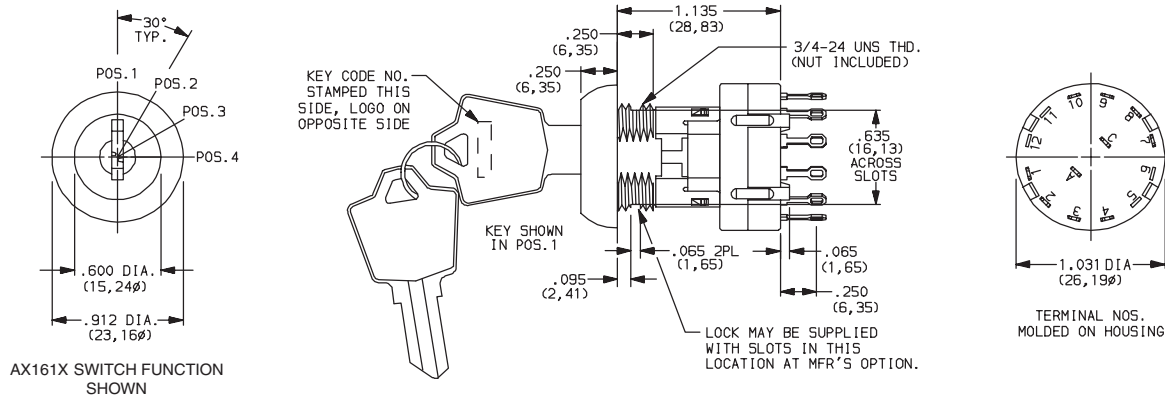

Part number shown: A116132Y2NZNQ



Dimensions are shown: Inch (mm)
Specifications and dimensions subject to change



A Series 4 & 5 Tumbler 1-4 Pole Switchlocks

KEYING

| OPTION CODE | KEYING OPTIONS | CODE NO. ON KEY | CODE NO. ON LOCK |
|-------------|----------------------------|-----------------|------------------|
| 2 | 2 NICKEL PLATED BRASS KEYS | YES | NO |

NOTE: All orders keyed alike, standard. For more than one key code, replacement keys, or other special features, consult Customer Service Center.

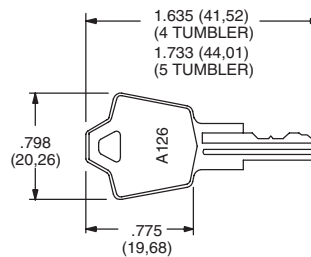

Key part number: 115140126

NOTE: Key head shape subject to change without notice.

LOCK TYPE

A 4 TUMBLER LOCK WITH REMOVABLE DRESS NUT

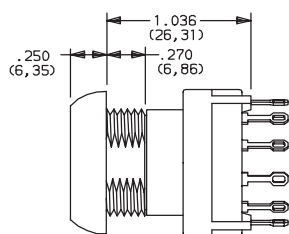

G 5 TUMBLER LOCK WITH ANTI-STATIC SWITCH

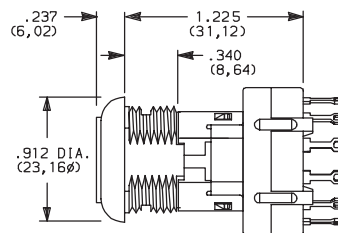

Y 4 TUMBLER LOCK WITH ANTI-STATIC SWITCH

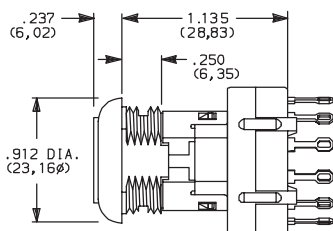

Not available with AX23 models.

| AVAILABLE OPTION COMBINATIONS | | |
|-------------------------------|-----------------|---|
| LOCK TYPES | MOUNTING STYLES | |
| | N | R |
| G | • | |
| A | | • |
| Y | • | |

NOTE: For available option combinations, see page L-38.

LOCK FINISH

2 STAINLESS STEEL

1 NICKEL

8 GLOSS BLACK



| AVAILABLE OPTION COMBINATIONS | | | | | |
|-------------------------------|------------|---|---|-----------------|---|
| FINISH OPTIONS | LOCK TYPES | | | MOUNTING STYLES | |
| | G | A | Y | N | R |
| 1 | | • | | | • |
| 2 | • | | • | • | |
| 8 | • | • | • | | • |

NOTE: For available option combinations, see page M-38.

SHORTING/NON-SHORTING

N NON-SHORTING CONTACTS (break-before-make)

S SHORTING CONTACTS (make-before-break)

Not available with AX14 models.



Dimensions are shown: Inch (mm)
Specifications and dimensions subject to change



Switchlock

A Series 4 & 5 Tumbler 1-4 Pole Switchlocks

TERMINATIONS

Z SOLDER LUG

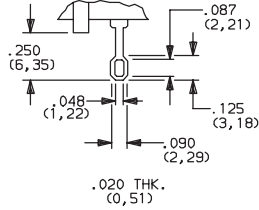

C PC THRU-HOLE

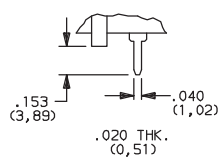

PC MOUNTING

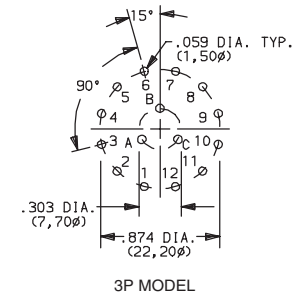
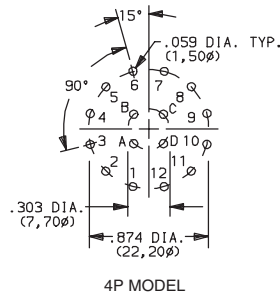

SP MODEL (omit terminals B, C, D)
DP MODEL (omit terminals B & D)

MOUNTING/LOCK STYLE

N WITH NUT

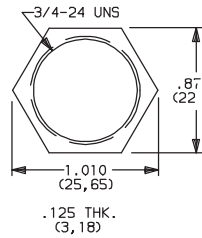

Nut part number: 937C00000

PANEL MOUNTING

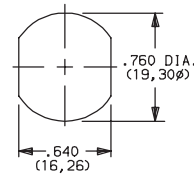

R REMOVABLE DRESS NUT

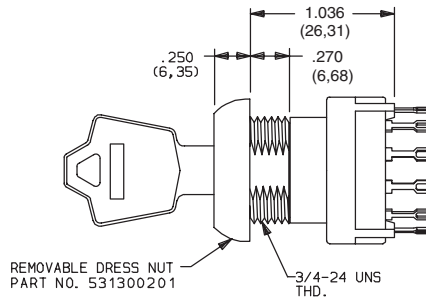
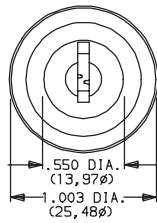

REMOVABLE DRESS NUT
PART NO. 531300201

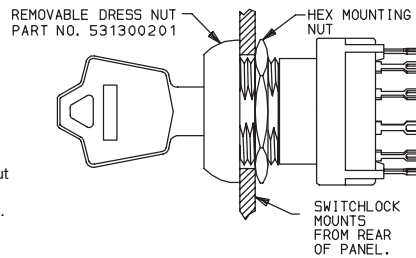

REMOVABLE DRESS NUT
PART NO. 531300201

HEX MOUNTING NUT

SWITCHLOCK MOUNTS FROM REAR OF PANEL.

PANEL MOUNTING

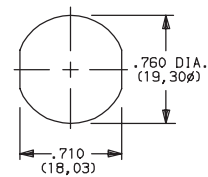

TYPICAL INSTALLATION

Install hex nut with enough clearance to allow for dress nut and panel. Place switch through cutout in rear of panel. Install and tighten dress nut by hand, then tighten hex nut. Always tighten assembly with back of panel hex nut to avoid damaging front of panel.



Switchlock



Dimensions are shown: Inch (mm)
Specifications and dimensions subject to change

www.ck-components.com

A Series 4 & 5 Tumbler 1-4 Pole Switchlocks

MOUNTING/LOCK STYLE

Mounting Information (All Models)

| MOUNTING STYLES | PANEL THICKNESS | |
|-----------------|------------------|------------------|
| | A & Y LOCK TYPES | G LOCK TYPES |
| N | .105 (2,67) max. | .195 (4,95) max. |
| R | .125 (3,18) max. | .215 (5,46) max. |

| AVAILABLE OPTION COMBINATIONS | | | | | | |
|-------------------------------|---------------|---|---|------------|---|---|
| MOUNTING STYLES | LOCK FINISHES | | | LOCK TYPES | | |
| | 1 | 2 | 8 | G | A | Y |
| N | | • | • | • | | • |
| R | • | | • | | • | |

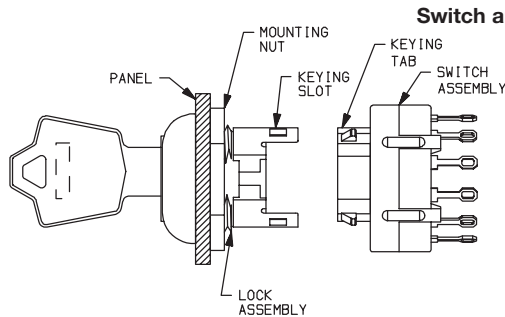

Switch and Lock Assembly Instructions

1. Place lock assembly in mounting hole on panel, secure with mounting nut.
2. Align keying tab on switch assembly with keying slot on lock assembly.
3. Snap assemblies together.
4. Switch installation is permanent. Switch cannot be removed from lock after assembly. Attempting to separate switch and lock may cause damage to switchlock.

CONTACT MATERIAL

| OPTION CODE | RoHS COMPLIANT* | RoHS COMPATIBLE* | CONTACT AND TERMINAL MATERIAL | RATING | |
|-------------|-----------------|------------------|-------------------------------|-----------------------|---|
| | | | | | |
| Q | YES | YES | SILVER ² | POWER | SWITCH-2.5 AMPS @ 125 V AC; 350 mA @ 125 V DC (UL/CSA). CARRY-5 AMPS CONTINUOUS. |
| B | YES | YES | GOLD ¹ | LOW LEVEL/DRY CIRCUIT | 0.4 VA MAX. @ 20 V AC or DC MAX. |

¹ MOVABLE CONTACT: Copper alloy, with gold plate over nickel plate.
STATIONARY CONTACTS & TERMINALS: Brass, with gold plate over nickel plate.
² MOVABLE CONTACT: Coin silver, silver plated.
STATIONARY CONTACTS & TERMINALS: Brass, silver plated (standard with all termination options).

* Note: See Technical Data section of this catalog for RoHS compliant and compatible definitions and specifications.

All models with all options when ordered with 'Q' contact material.

SEAL

NONE NO SEAL

E EPOXY SEAL

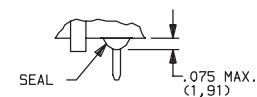

AVAILABLE HARDWARE



Key Code: A126
4 TUMBLER
PART NO. (ONE KEY)
115140126
Material: Brass
Finish: Nickel plate

Key Code: D001
5 TUMBLER
PART NO. (ONE KEY)
115441001
Material: Brass
Finish: Nickel plate

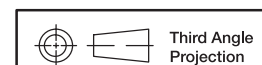

Dimensions are shown: Inch (mm)
Specifications and dimensions subject to change



Switchlock

H Series 4 & 6 Tumbler Power Switchlocks

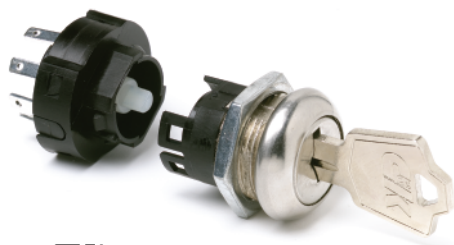

Models Available

Features/Benefits

- Positive detent
- Multi-pole and multi-position
- Snap-together assembly
- Power switching

Typical Applications

- Machine controls
- Elevators

Specifications

CONTACT RATING: Q contact material: 12 AMPS @ 125 V AC; 6 AMPS @ 250 V AC; 1 AMP @ 125 V DC (UL/CSA). See page L-37 for additional ratings.

ELECTRICAL LIFE: 10,000 make-and-break cycles at full load.

CONTACT RESISTANCE: Below 10 m Ω typ. initial @ 2-4 V DC, 100 mA, for both silver and gold plated contacts.

INSULATION RESISTANCE: 10⁹ Ω min.

DIELECTRIC STRENGTH: 1,000 Vrms min. @ sea level.

OPERATING TEMPERATURE: -30°C to 85°C.

INDEXING: 45° or 90°, 2-4 Positions.

NOTE: Any models supplied with Q or B contact material are RoHS compliant.

NOTE: Specifications and materials listed above are for switchlocks with standard options. For information on specific and custom switchlocks, consult Customer Service Center.

Materials

LOCK: Zinc alloy with stainless steel facing (4 tumbler locks and 6 tumbler tubular lock).

KEYS: Two nickel plated brass keys with code number (4 tumbler). Two die cast chrome plated zinc alloy keys (6 tumbler).

SWITCH HOUSING: 6/6 nylon (UL 94V-2).

CONTACTS & TERMINALS: Q contact material: Copper, silver plated. See page L-37 for additional contact materials.

CONTACT SPRING: Music wire or stainless steel.

MOUNTING NUT: Zinc alloy.

MOUNTING CLIP: Steel, zinc plated.

DRESS NUT: Brass, nickel plated.

TERMINAL SEAL: Epoxy.

Build-A-Switch

To order, simply select desired option from each category and place in the appropriate box. Available options are shown and described on pages L-35 through L-38. For additional options not shown in catalog, consult Customer Service Center.

Switch and Lock Function

- H10113** SP, 90° Index, keypull pos.1
- H2011U** DP, 90° Index, keypull pos. 1 & 2
- H100AA** SP, 45° Index, keypull pos. 1,2 & 3
- H200AA** DP, 45° Index, keypull pos. 1, 2 & 3
- H20113** DP, 90° Index, keypull pos. 1
- H1011U** SP, 90° Index, keypull pos.1 & 2
- H1417U** SP, 90° Index, keypull pos. 1,2 & 3

Keying

- 2** Two nickel plated brass keys (4 tumbler) or two die cast zinc alloy keys with chrome plating (6 tumbler)
- T** One nickel plated brass key with plastic insert molded square head and one nickel plated brass key

Lock Type

- F** 4 Tumbler lock with detent
- V** 6 Tumbler tubular lock

Lock Finish

- 2** Stainless steel facing
- 8** Gloss black facing

Terminations

- 05** Quick connect
- WC** Wire lead

Mounting/Lock Style

- N** With nut
- D** With clip

Contact Material

- Q** Silver
- B** Gold

Key Color

- NONE** Nickel plated brass (4 tumbler) or chrome plated zinc alloy (6 tumbler)
- 2** Black

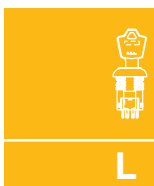

Switchlock



Dimensions are shown: Inch (mm)
Specifications and dimensions subject to change

H Series 4 & 6 Tumbler Power Switchlocks

SWITCH AND LOCK FUNCTION



| NO. TUMBLERS | NO. POLES | MODEL NO. | CONNECTED TERMINALS | | | | KEY PULL POSITIONS | LOCK CONFIGURATION | INDEXING |
|--------------|-----------|--------------------------------|---------------------|-----------------|-----------------|--------|--------------------|--------------------|----------|
| | | | POS. 1 | POS. 2 | POS. 3 | POS. 4 | | | |
| 4 | SP DP | H100AA H200AA | 7-8 7-8, 3-4 | 8-1 8-1, 4-5 | 6-7 6-7, 2-3 | | Positions 1, 2 & 3 | | 45° |
| 4 & 6 | SP DP | H10113 H20113 | 7-8 7-8, 3-4 | 8-2 8-2, 4-6 | | | Position 1 | | |
| 4 & 6 | SP DP | H1011U H2011U | 7-8 7-8, 3-4 | 8-2 8-2, 4-6 | | | Positions 1 & 2 | | 90° |
| 4 | SP | H1417U | 6-8 | 8-2 | 5-6 | | Positions 1, 2 & 3 | | |

All models with all options when ordered with 'G' or 'Q' contact material.

TERMINAL NUMBERS

LEGEND

- = Detent Positions (45° or 90°)
- ⊙ = Key pull possible in these positions.
- = Stop Positions

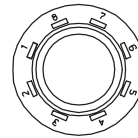

Terminal numbers molded on housing.

4 Tumbler

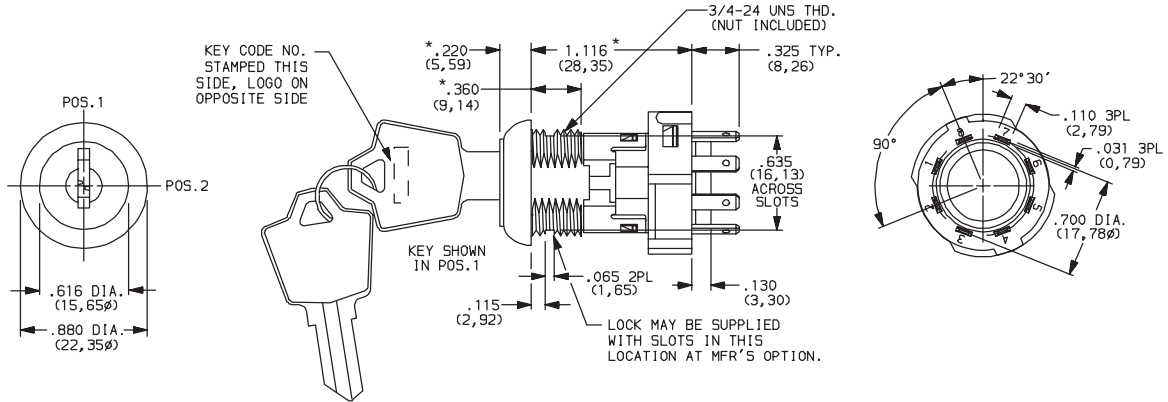

Part number shown: H101132F205NQ

6 Tumbler

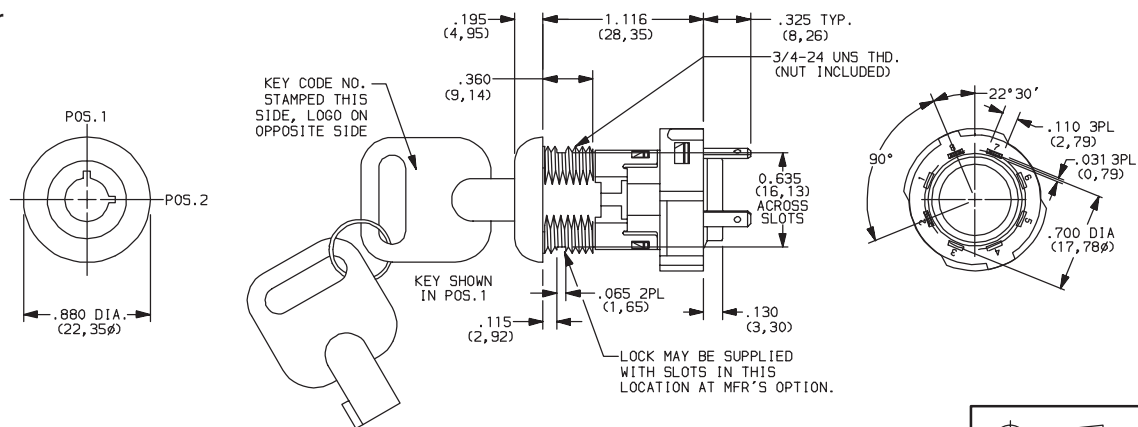

Part number shown: H1011U2V205NQ



Dimensions are shown: Inch (mm)
Specifications and dimensions subject to change



H Series 4 & 6 Tumbler Power Switchlocks

KEYING

| OPTION CODE | KEY OPTIONS | CODE NO. ON KEY | CODE NO. ON LOCK |
|-------------|--|-----------------|------------------|
| 2 | 2 NICKEL PLATED BRASS KEYS (4 TUMBLER) OR 2 CHROME PLATED ZINC ALLOY KEYS (6 TUMBLER) | YES | NO |
| T | 1 NICKEL PLATED BRASS KEY WITH PLASTIC INSERT MOLDED SQUARE HEAD & 1 NICKEL PLATED BRASS KEY | YES | NO |

| OPTION CODE | KEY COLOR |
|-------------|---|
| NONE | NICKEL PLATED BRASS (4 TUMBLER) OR CHROME PLATED ZINC ALLOY (6 TUMBLER) |
| 2 | BLACK |

NOTE: All orders keyed alike, standard. For more than one key code, replacement keys, or other special features, consult Customer Service Center.

NICKEL PLATED BRASS KEY

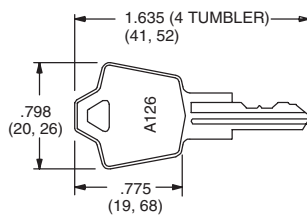

Key part number: 115140126

NICKEL PLATED BRASS KEY WITH PLASTIC INSERT MOLDED SQUARE HEAD

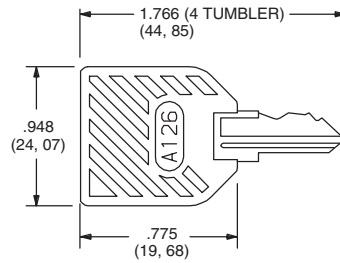

Key part number: 11599112602

CHROME PLATED ZINC ALLOY KEY

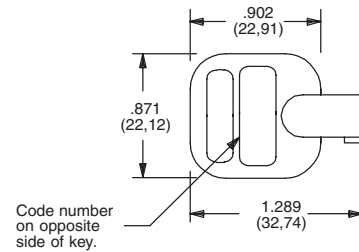

Key part number: 363C1AAAA

NOTE: Key head shape subject to change without notice.

LOCK TYPE

F 4 TUMBLER LOCK WITH ADDED DETENT

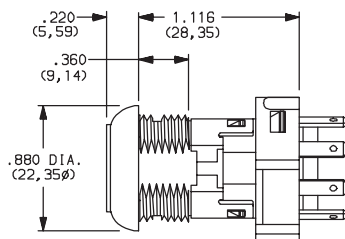

V 6 TUMBLER TUBULAR LOCK

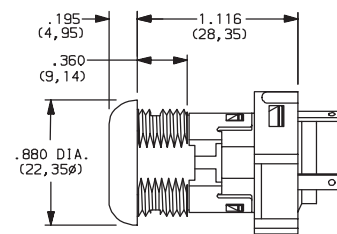

LOCK FINISH

2 STAINLESS STEEL FACING



Available with V lock type only.

8 GLOSS BLACK FACING



Switchlock

TERMINATIONS

05 .110" QUICK CONNECT

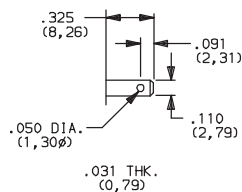

WC WIRE LEAD

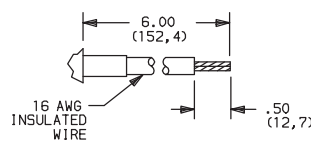

Black wire standard, other colors, gages and lengths available, consult Customer Service Center. UL style 1015.



Dimensions are shown: Inch (mm)
Specifications and dimensions subject to change



H Series 4 & 6 Tumbler Power Switchlocks

MOUNTING/LOCK STYLE

N WITH NUT

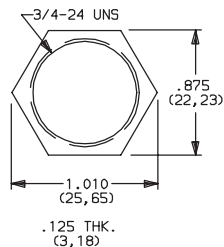

Nut part number: 937C00000

D WITH CLIP

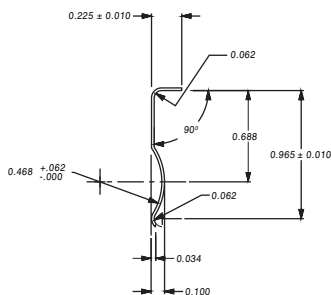

Clip part number: 906B00000

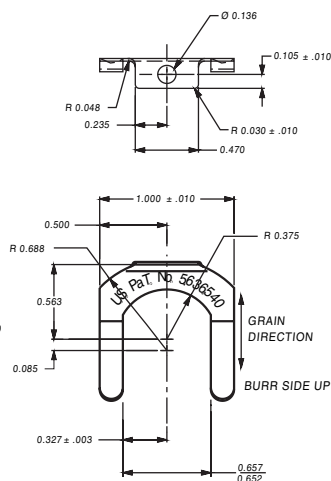

PANEL MOUNTING

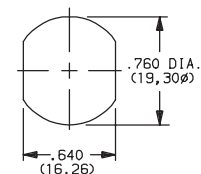

| MOUNTING STYLES | PANEL THICKNESS |
|-----------------|-----------------------|
| D | .065-.085 (1,65-2,16) |
| N | .195 (4,95) max. |

Switch and Lock Assembly Instructions

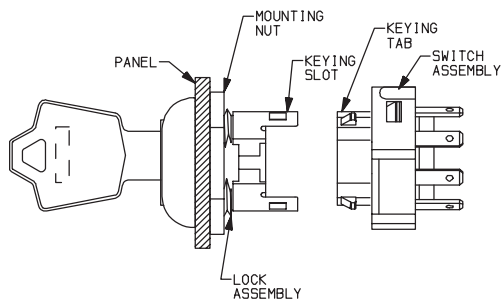

1. Place lock assembly in mounting hole on panel, secure with mounting nut.
2. Align keying tab on switch assembly with keying slot on lock assembly.
3. Snap assemblies together.
4. Switch installation is permanent. Switch cannot be removed from lock after assembly. Attempting to separate switch and lock may cause damage to switchlock.

CONTACT MATERIAL

| OPTION CODE | RoHS COMPLIANT* | RoHS COMPATIBLE* | CONTACT AND TERMINAL MATERIAL | RATING | |
|-------------|-----------------|------------------|-------------------------------|-----------------------|---|
| | | | | | |
| Q | YES | YES | SILVER ² | POWER | 12 AMPS @ 125 V AC; 6 AMPS @ 250 V AC; 1 AMP @ 125 V DC (UL/CSA). |
| B | YES | YES | GOLD ¹ | LOW LEVEL/DRY CIRCUIT | 0.4 VA MAX. @ 20 V AC or DC MAX. |

¹ CONTACTS & TERMINALS: Copper, with gold plate over nickel plate.
² CONTACTS & TERMINALS: Copper, silver plated.

* Note: See Technical Data section of this catalog for RoHS compliant and compatible definition and specifications.

All models  with all options when ordered with 'Q' contact material.



Dimensions are shown: Inch (mm)

Specifications and dimensions subject to change



Switchlock

H Series 4 & 6 Tumbler Power Switchlocks

AVAILABLE HARDWARE



Key Code: A126
4 TUMBLER
PART NO. (ONE KEY)
115140126
Material: Brass
Finish: Nickel plate



Key Code: AAAA
PART NO. (ONE KEY)
363C1AAAA
Material: Zinc Alloy
Finish: Chrome plate



Key Code: A126
4 TUMBLER
PART NO. (ONE KEY)
1159112602 BLACK
Material: Brass
Finish: Nickel plate
6/6 Nylon insert molded head



Switchlock

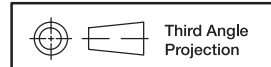

Dimensions are shown: Inch (mm)
Specifications and dimensions subject to change

PL Series 5 Tumbler Miniature Camlocks

Features/Benefits

- Cost-effective security
- Custom cams available

Typical Applications

- Office furniture
- Cash registers
- Copy machines



Specifications

INDEXING: 90°: 2 positions.

NOTE: Specifications and materials listed above are for camlocks with standard options. For information on specific and custom camlocks, consult Customer Service Center.

Materials

LOCK: 6/6 nylon (UL 94V-2). Color, black.

5 tumbler, single bitted lock with integral detent mechanism.

KEYS: Two nickel plated brass keys with black plastic insert molded head.

CAM: 6/6 nylon (UL 94V-2).

Build-A-Switch

To order, simply select desired option from each category and place in the appropriate box. Available options are shown and described on pages L-40 and L-41. For additional options not shown in catalog, consult Customer Service Center.

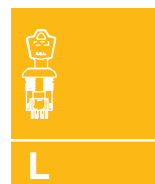
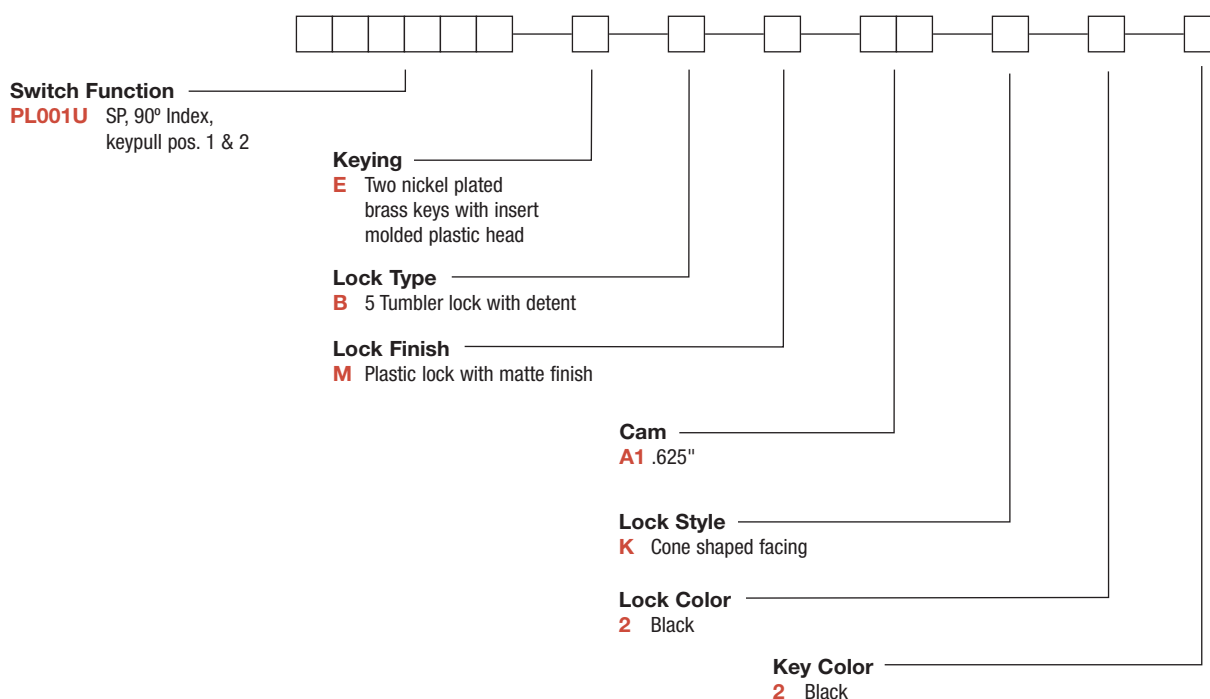

Switchlock

PL Series 5 Tumbler Miniature Camlocks

LOCK FUNCTION

| MODEL NO. | KEY PULL POSITIONS | LOCK CONFIGURATION | INDEXING |
|---------------|--------------------|---|----------|
| PL001U | Positions 1 & 2 |  | 90° |

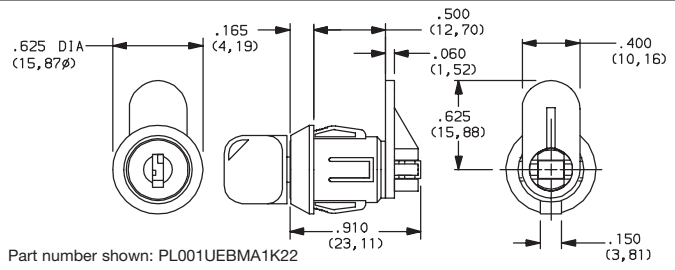

Part number shown: PL001UEBMA1K22

LEGEND

- = Detent Position (90°)
- ⊙ = Key pull possible in these positions.
- ⊙ = Stop Positions

KEYING

E TWO NICKEL PLATED BRASS KEYS WITH INSERT MOLDED PLASTIC HEAD

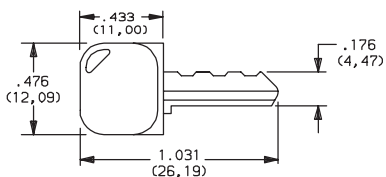

Key part number: 617D1004102

| OPTION CODE | KEY COLOR |
|-------------|-----------|
| 2 | BLACK |

NOTE: All orders keyed alike, standard. For more than one key code, replacement keys, or other special features, consult Customer Service Center.

LOCK TYPE

B 5 TUMBLER LOCK WITH DETENT

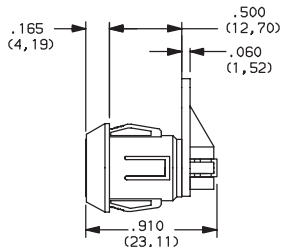

| OPTION CODE | LOCK COLOR |
|-------------|------------|
| 2 | BLACK |

LOCK FINISH

M PLASTIC LOCK WITH MATTE FINISH



Third Angle Projection

Dimensions are shown: Inch (mm)
Specifications and dimensions subject to change



Switchlock

PL Series 5 Tumbler Miniature Camlocks

CAM

A1 .625"

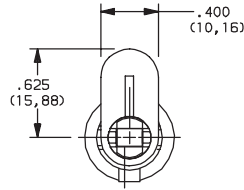

NOTE: Cam not assembled to switch. Other cam lengths and styles available, consult Customer Service Center.

LOCK STYLE

K CONE SHAPED FACING

PANEL MOUNTING

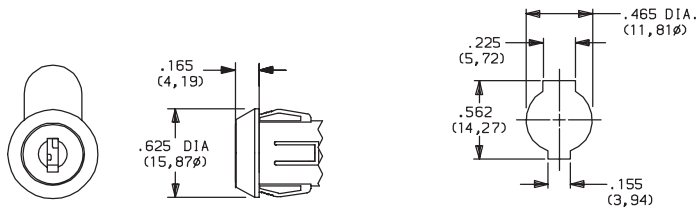

Panel thickness: .050-.080 (1,27-2,03)

AVAILABLE HARDWARE



Key Code: 041

PART NO. (ONE KEY)

617D1004102 BLACK

Material: Brass
Finish: Nickel plate
6/6 Nylon insert molded head



Switchlock



Third Angle Projection

Dimensions are shown: Inch (mm)
Specifications and dimensions subject to change

Thumbwheel Product Selection Guide

| | |
|----------------------------|---|
| Thumbwheel |  |
| Series | 3 |
| Switch Type | Thumbwheel |
| Sealed | • |
| Dust Lens | • |
| Max. Current | 1 Amp |
| Actuators | |
| Thumbwheel Actuator | • |
| Number of Positions | |
| 10 Position | • |
| 16 Position | • |
| Mounting Options | |
| Board Mount w/Pins | • |
| Front Mount | • |
| Rear Mount | • |
| Snap-in | • |
| Page Number | M-3 |

Thumbwheel



*Dimensions are shown: Inches (mm)
Specifications and dimensions subject to change*

3 Series Thumbwheel Switches

Features/Benefits

- Most complete product offering in the industry
- Spacers available to fit most panel cutouts
- Front or rear mounting options

Typical Applications

- Test & measurement equipment
- Industrial equipment
- Computer devices



Specifications

CONTACT RATING:
 CARRY: 1 AMP continuous.
 SWITCH: 100 mA max.
 OPERATING VOLTAGE: 50 mV to 28 V DC or 120 V AC.
 ELECTRICAL LIFE: 100,000 actuations.
 CONTACT RESISTANCE: Below 100 m Ω typ. initial @ 2-4 V DC, 100 mA.
 INSULATION RESISTANCE: 10⁹ Ω min.
 DIELECTRIC STRENGTH: 500 Vrms min. @ sea level between common terminal and any output.
 OPERATING TEMPERATURE: -40°C to 65°C.

Materials

HOUSING: ABS plastic.
 THUMBWHEEL: ABS plastic.
 ROTOR CONTACTS: Precious metal on copper alloy.
 STATOR CONTACTS: Hard gold over nickel over copper on epoxy fiberglass.

NOTE: Specifications and materials listed above are for switches with standard options. For information on specific and custom switches, consult Customer Service Center.

* Note: All models listed are RoHS compliant. See Technical Data section of this catalog for RoHS compliant and compatible definitions and specifications.

Build-A-Switch

To order, simply select desired option from each category and place in the appropriate box. Available options are shown and described on pages M-4 thru M-10. For additional options not shown in catalog, consult Customer Service Center. Consult factory for illumination availability.

| | | | | | | |
|--|--|--|---|--|--|--|
| <p>Series</p> <p>3 Thumbwheel switch</p> | <p>Number of Sections</p> <p>0 Switch section 1 1 Switch section 2 2 Switch sections 3 3 Switch sections 4 4 Switch sections 5 5 Switch sections 6 6 Switch sections 7 7 Switch sections 8 8 Switch sections 9 More than 8 switch sections</p> | <p>Function Code</p> <p>11 Decimal, SP, 10 position 14 Resistor decade 21 BCD, 10 position 23 Complement of BCD, 10 position 27 BCD, 10 position 31 BCD, 10 position 71 BCH, 16 position</p> | <p>Mounting Style</p> <p>00 Snap-in, front mount 09 Snap-in, front mount* 10 Rear mount 19 Rear mount* 20 Rear mount 29 Rear mount*</p> | <p>Terminations</p> <p>0 Type 0 1 Type 1, extended type 0 N Solder pins with .100" spacing** P Solder pins with .156" spacing** 6 Type 6 No pins 9 Any combination</p> | <p>Color/Marking/Stops</p> <p>0 Matte black body, gloss black wheel, white marking</p> | <p>Seal</p> <p>0 No seal 1 Sealed contacts 2 Dust lens 3 Sealed contacts & dust lens</p> |
|--|--|--|---|--|--|--|

*X9 mounting styles must be ordered with '0' number of sections.

** Note: Termination option N (RoHS compliant) replaced termination option 3 (Non-RoHS compliant).
 Termination option P (RoHS compliant) replaced termination option B (Non-RoHS compliant).

Thumbwheel



Dimensions are shown: Inches (mm)
 Specifications and dimensions subject to change

3 Series Thumbwheel Switches

SERIES

3 THUMBWHEEL SWITCHES

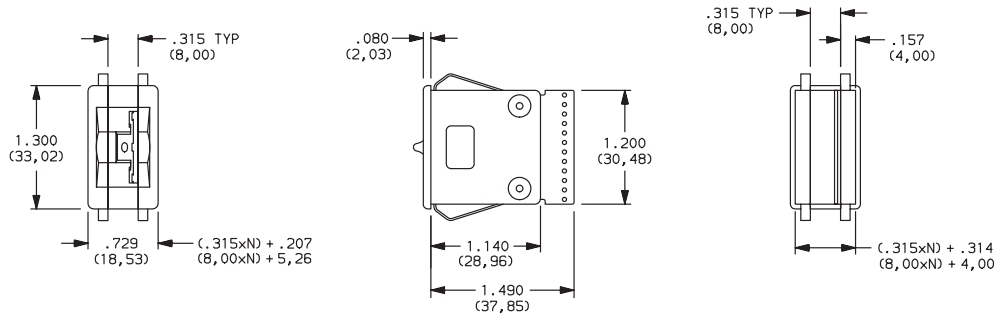

NUMBER OF SECTIONS

- 0** Switch section only, no assembly. Blank bodies are considered sections; endplates are not sections. Must be ordered with 09 or 19 mounting style options, see pages M-5 and M-6.
- 1-8** Number of switch sections in assembly, includes endplates.
- 9** More than 8 switch sections, specify on CONFIGURATION FORM, page M-10 and consult Customer Service Center.

NOTE: Endplates and blank sections available separately, see pages M-13 and M-14.

FUNCTION CODE

- 11** DECIMAL-1 POLE; 10 POSITION
- 14** RESISTOR DECADE; 1-2-2-2-2 CODE (RESISTORS NOT SUPPLIED)
- 21** BCD 1-2-4-8; 10 POSITION

Thumbwheel



M

| W H E E L | SIGNALS CONNECTED TO COMMON SIGNAL C | | | | | | | | | | C |
|-----------------------|--------------------------------------|---|---|---|---|---|---|---|----|----|----|
| | 0 | 1 | 2 | 3 | 4 | 5 | 6 | 7 | 8 | 9 | |
| 0 | ● | | | | | | | | | | ● |
| 1 | | ● | | | | | | | | | ● |
| 2 | | | ● | | | | | | | | ● |
| 3 | | | | ● | | | | | | | ● |
| 4 | | | | | ● | | | | | | ● |
| 5 | | | | | | ● | | | | | ● |
| 6 | | | | | | | ● | | | | ● |
| 7 | | | | | | | | ● | | | ● |
| 8 | | | | | | | | | ● | | ● |
| 9 | | | | | | | | | | ● | ● |
| | 2 | 3 | 4 | 5 | 6 | 7 | 8 | 9 | 10 | 11 | 12 |
| | TERM. LOCATION | | | | | | | | | | |

Available Terminations: 0, 1, N
See fig. 1, page M-7.

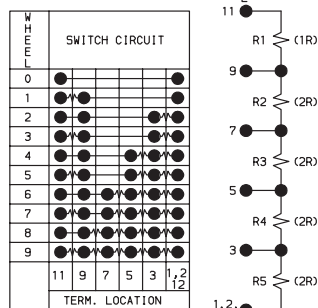

Available Terminations: 1
See fig. 1, page M-7.

| W H E E L | SIGNALS CONN. TO COMM. SIG. C | | | | |
|-----------------------|-------------------------------|---|---|----|---|
| | 1 | 2 | 4 | 8 | |
| 0 | | | | ● | |
| 1 | ● | | | ● | |
| 2 | | ● | | ● | |
| 3 | ● | ● | | ● | |
| 4 | | | ● | ● | |
| 5 | ● | ● | ● | ● | |
| 6 | ● | ● | ● | ● | |
| 7 | ● | ● | ● | ● | |
| 8 | | | ● | ● | |
| 9 | ● | | | ● | |
| | 3 | 5 | 7 | 11 | 9 |
| | TERM. LOCATION | | | | |

Available Terminations: 0, 1, N
See fig. 1, page M-7.

NOTE: For terminal location diagram, see page M-7.

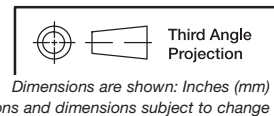

3 Series Thumbwheel Switches

FUNCTION CODE

23 COMPLEMENT OF BCD 1-2-4-8;
10 POSITION

| W H E E L | SIGNALS CONN. TO COMM. SIG. C | | | |
|-----------------------|----------------------------------|---|----|---|
| | 1 | 2 | 4 | 8 |
| 0 | ● | ● | ● | ● |
| 1 | ● | ● | ● | ● |
| 2 | ● | ● | ● | ● |
| 3 | ● | ● | ● | ● |
| 4 | ● | ● | ● | ● |
| 5 | ● | ● | ● | ● |
| 6 | ● | ● | ● | ● |
| 7 | ● | ● | ● | ● |
| 8 | ● | ● | ● | ● |
| 9 | ● | ● | ● | ● |
| TERM. LOCATION | | | | |
| | 3 | 9 | 11 | 5 |
| | 7 | | | |

Available Terminations: 0, 1, N
See fig. 1, page M-7.

27 BCD 1-2-4-8; 10 POSITION

| W H E E L | SIGNALS CONN. TO COMM. SIG. C | | | |
|-----------------------|----------------------------------|---|---|---|
| | 1 | 2 | 4 | 8 |
| 0 | | | | ● |
| 1 | ● | | | ● |
| 2 | ● | | | ● |
| 3 | ● | | | ● |
| 4 | ● | | | ● |
| 5 | ● | | | ● |
| 6 | ● | | | ● |
| 7 | ● | | | ● |
| 8 | ● | | | ● |
| 9 | ● | | | ● |
| TERM. LOCATION | | | | |
| | 4 | 5 | 1 | 2 |
| | 3 | | | |

Available Terminations: P
See fig. 2, page M-7.

31 BCD 1-2-4-8; 10 POSITION

| W H E E L | SIGNALS CONN. TO COMM. SIG. C | | | |
|-----------------------|----------------------------------|---|----|---|
| | 1 | 2 | 4 | 8 |
| 0 | | | | ● |
| 1 | ● | | | ● |
| 2 | ● | | | ● |
| 3 | ● | | | ● |
| 4 | ● | | | ● |
| 5 | ● | | | ● |
| 6 | ● | | | ● |
| 7 | ● | | | ● |
| 8 | ● | | | ● |
| 9 | ● | | | ● |
| TERM. LOCATION | | | | |
| | 2 | 3 | 11 | 9 |
| | 8 | | | |

Available Terminations: 0, 1, N
See fig. 1, page M-7.

71 BINARY CODED HEXADECIMAL,
16 POSITION

| W H E E L | SIGNALS CONN. TO COMM. SIG. C | | | |
|-----------------------|----------------------------------|---|---|----|
| | 1 | 2 | 4 | 8 |
| 0 | | | | ● |
| 1 | ● | | | ● |
| 2 | ● | | | ● |
| 3 | ● | | | ● |
| 4 | ● | | | ● |
| 5 | ● | | | ● |
| 6 | ● | | | ● |
| 7 | ● | | | ● |
| 8 | ● | | | ● |
| 9 | ● | | | ● |
| TERM. LOCATION | | | | |
| | 3 | 5 | 7 | 11 |
| | 9 | | | |

Available Terminations: 0, 1, N
See fig. 1, page M-7.

NOTE: For terminal location diagram, see page M-7.

MOUNTING STYLE

Type 0 Snap-In Front Mount

| MOUNTING STYLE | DIM. 'A' |
|-------------------|--|
| 00 | $(.315 \times N) + .326$ $(8,00 \times N) + (8,28)$ |

N = Number of sections.

Recommended panel thickness:
0.46-.125
(1,16-3,18)

PANEL MOUNTING

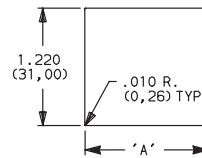

00 SWITCH ASSEMBLY W/ ENDPLATES--315 (8,00) SECTION PITCH

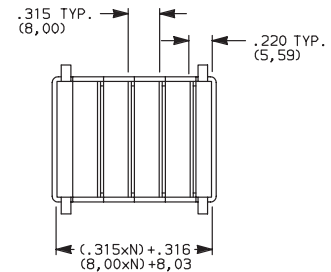
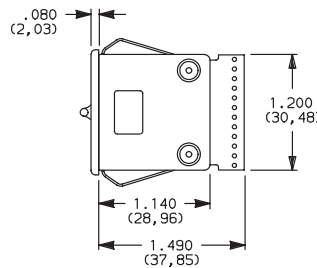
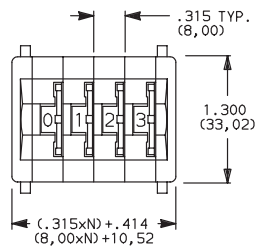

N = Number of sections.

09 SWITCH SECTION ONLY--UNASSEMBLED WITHOUT ENDPLATES OR SPACERS
(Must be ordered with number of sections option "0", see Page M-4.)

NOTE: Endplates, blank sections, spacers
and assembly hardware available separately, see pages M-8 and M-9.

Thumbwheel



M

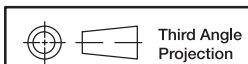

Dimensions are shown: Inches (mm)
Specifications and dimensions subject to change

3 Series Thumbwheel Switches

MOUNTING STYLE

Type 1 Rear Mount

| MOUNTING STYLE | DIM. 'A' | DIM. 'B' |
|----------------|---|--|
| 10 | $(.350 \times N) + .340$ (8,89 x N) + (8,64) | $(.350 \times N) + .560$ (8,89 x N) + (14,22) |

N = Number of sections.
Recommended panel thickness:
0,46-.125
(1,16-3,18)

PANEL MOUNTING

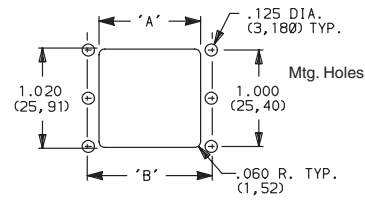

10 SWITCH ASSEMBLY W/ ENDPLATES--.350 (8,89) SECTION PITCH

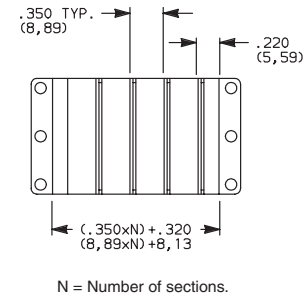
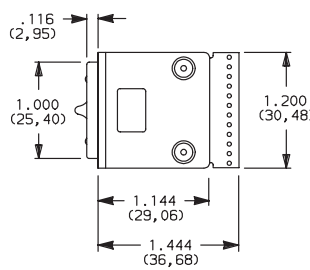
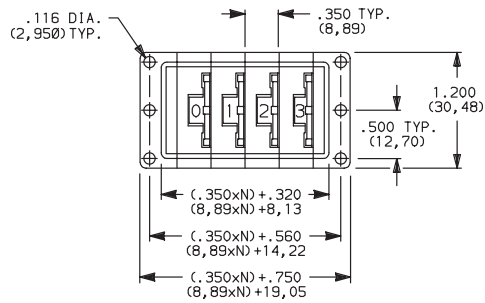

19 SWITCH SECTION ONLY--UNASSEMBLED WITHOUT ENDPLATES OR SPACERS (Must be ordered with number of sections option "0", see Page M-4.)

Type 2 Rear Mount

20 SWITCH ASSEMBLY W/ ENDPLATES--.350 (8,89) SECTION PITCH

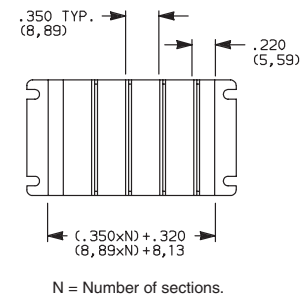
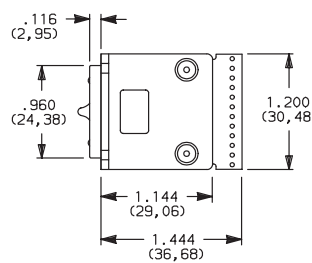
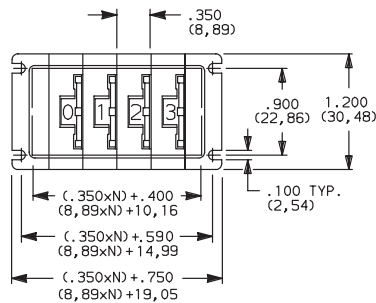

29 SWITCH SECTION ONLY--UNASSEMBLED WITHOUT ENDPLATES OR SPACERS (Must be ordered with number of sections option "0", see Page M-4.)

Thumbwheel



M

NOTE: Endplates, blank sections, spacers and assembly hardware available separately, see pages M-8 and M-9.

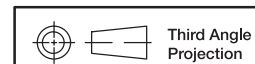

Third Angle Projection
Dimensions are shown: Inches (mm)
Specifications and dimensions subject to change



3 Series Thumbwheel Switches

TERMINATIONS

0 TYPE 0

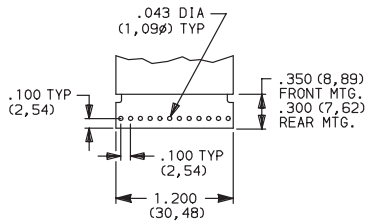

1 TYPE 1, EXTENDED TYPE 0

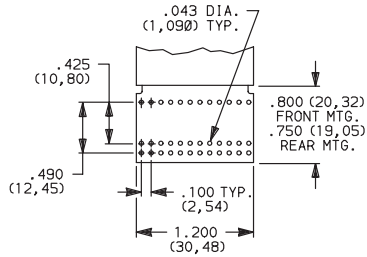

Signal traces cut except for common(s).

N SOLDER PINS WITH .100" SPACING

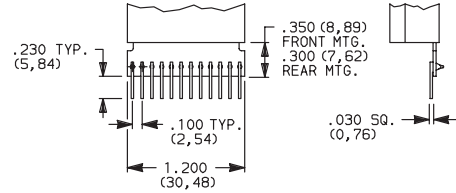

P SOLDER PINS WITH .156" SPACING

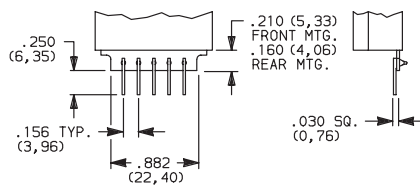

PC Board 1/32" (0,79) thick.

6 TYPE 6, NO PINS

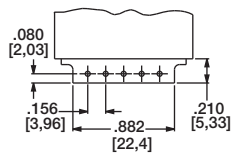

9 ANY COMBINATION OF TERMINATION CONFIGURATIONS OR SPECIAL TERMINATIONS.

Specify on configuration form, page M-10 and consult Customer Service Center.

NOTE: All terminal holes shown may not be present for all function codes, consult Customer Service Center. Terminal connector available for termination options 0 & 1, see page M-9.

NOTE: Termination option N (RoHS compliant) replaced termination option 3 (Non-RoHS compliant). Termination option P (RoHS compliant) replaced termination option B (Non-RoHS compliant).

Terminal Location Numbers

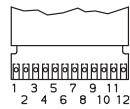

FIG. 1

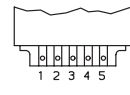
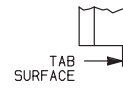

FIG. 2



NOTE: See function codes, pages M-4 and M-5, for signal locations.

COLOR/MARKING/STOPS

0 MATTE BLACK HOUSING (Gloss black wheel with white characters; no stops.)

NOTE: Stop pins are available separately, see page M-8.

SEAL

0 UNSEALED SWITCHING CONTACTS.

1 SEALED SWITCHING CONTACTS. (Sealing is by means of an o-ring rotary seal and a cured-in-place elastomer gasket. Switching contact area is protected from moisture, oil, and airborne contaminants.)

2 DUST LENS. (Protects the character face of the wheel from abrasion and dirt).

3 SEALED SWITCHING CONTACTS AND DUST LENS



Dust Lens

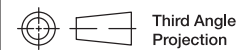

Third Angle Projection

Dimensions are shown: Inches (mm)
Specifications and dimensions subject to change



3 Series Thumbwheel Switches

AVAILABLE HARDWARE

Blank sections, Type 0,
.315 THK.



PART NO.
413602000 W/RIB-BLACK
400502000 W/RIB & W/OUT SPRINGS-BLACK

Blank sections, Front mount, Type 0,
.315 THK.



PART NO.
413502000 PLAIN-BLACK
400702000 PLAIN & W/OUT SPRINGS-BLACK

Blank sections, Rear mount, Type 1,
.350 THK.



PART NO.
400602000 W/RIB-BLACK
400802000 PLAIN-BLACK

Blank sections, Rear mount, Type 2,
.350 THK.



PART NO.
473402000 W/RIB-BLACK
473302000 PLAIN-BLACK

End plates, Front mount, Type 0



PART NO.
413402000 BLACK
Two required for complete assembly.

End plates, Rear mount, Type 1



PART NO.
400402003 BLACK
Two required for complete assembly.

End plates, Rear mount, Type 2



PART NO.
473202003 BLACK
Two required for complete assembly.

Spacers, Front mount, Type 0 & 3, .078 THK.
(Makes section pitch 10mm)



PART NO.
410802000 BLACK

Stop pins



PART NO.
402900000

Thumbwheel



*Dimensions are shown: Inches (mm)
Specifications and dimensions subject to change*

3 Series Thumbwheel Switches

AVAILABLE HARDWARE

Terminal connector



605A00000



605A02000

PART NO.

605A00000 PC

605A02000 SOLDER LUG

Fits 0 & 1 terminations only.

Screws for field assembly of thumbwheel switches
(2 screws needed per assembly + 403500000 nuts)

| SCREW PART NUMBER (0-80 UNF THD. SIZE) | NUMBER OF SECTIONS IN ASSEMBLY | |
|---|--------------------------------|-----------------|
| | FRONT MOUNTING | REAR MOUNTING |
| | MTG. STYLE - 00 | MTG. STYLE - 10 |
| 412700000 | 1-2 | 1-2 |
| 412701000 | 3-4 | 3 |
| 412702000 | 5-7 | 4-6 |

Nut



Two nuts required per assembly and screws.

PART NO.

403500000

Nut driver (For 403500000 nut)



PART NO.

406100652

Thumbwheel



Dimensions are shown: Inches (mm)
Specifications and dimensions subject to change

3 Series Thumbwheel Switches

Configuration Form

GRAY SHADED AREAS TO BE FILLED IN BY CUSTOMER SERVICE.

CATALOG PART NO.

3

C&K PART NUMBER

C&K PART NUMBER

COMPANY NAME _____











CUSTOMER PRINT REVISION:

ADDRESS _____ TEL.# _____

CUSTOMER CONTACT _____ DATE _____

DETAILS:

ORIGINATED BY _____ SALES REP. _____

| THUMBWHEEL SECTIONS | NO. OF SEC. | FUNCTION CODE – TERMINATIONS – COLOR/MARKING/STOPS/SEAL – ILLUMINATION <small>ENTER OPTION CODES IN APPROPRIATE BOXES. FUNCTION CODES INCLUDE BLANK SECTIONS (SEE PAGES M-9 & M-10).</small> | DESCRIBE IN APPROPRIATE ROW |
|---|-------------|---|-----------------------------|
|  | 1 | 3 - <input type="text"/> <input type="text"/> - - <input type="text"/> <input type="text"/> <input type="text"/> <input type="text"/> | |
|  | 2 | 3 - <input type="text"/> <input type="text"/> - - <input type="text"/> <input type="text"/> <input type="text"/> <input type="text"/> | |
|  | 3 | 3 - <input type="text"/> <input type="text"/> - - <input type="text"/> <input type="text"/> <input type="text"/> <input type="text"/> | |
|  | 4 | 3 - <input type="text"/> <input type="text"/> - - <input type="text"/> <input type="text"/> <input type="text"/> <input type="text"/> | |
|  | 5 | 3 - <input type="text"/> <input type="text"/> - - <input type="text"/> <input type="text"/> <input type="text"/> <input type="text"/> | |
|  | 6 | 3 - <input type="text"/> <input type="text"/> - - <input type="text"/> <input type="text"/> <input type="text"/> <input type="text"/> | |
|  | 7 | 3 - <input type="text"/> <input type="text"/> - - <input type="text"/> <input type="text"/> <input type="text"/> <input type="text"/> | |
|  | 8 | 3 - <input type="text"/> <input type="text"/> - - <input type="text"/> <input type="text"/> <input type="text"/> <input type="text"/> | |
|  | 9 | 3 - <input type="text"/> <input type="text"/> - - <input type="text"/> <input type="text"/> <input type="text"/> <input type="text"/> | |
|  | 10 | 3 - <input type="text"/> <input type="text"/> - - <input type="text"/> <input type="text"/> <input type="text"/> <input type="text"/> | |
|  | 11 | 3 - <input type="text"/> <input type="text"/> - - <input type="text"/> <input type="text"/> <input type="text"/> <input type="text"/> | |

Thumbwheel



QUALITY CONTROL INSTRUCTIONS

PRODUCTION APPROVAL

DATE

Q.C. APPROVAL

DATE

REV.

INITIALS

DATE

FOR SWITCHES WITH MORE THAN 11 SECTIONS, CONTINUE ON ADDITIONAL SHEETS.

SPECIAL INSTRUCTIONS OR SPECIFICATIONS:

SHEET ____ OF ____



Dimensions are shown: Inches (mm)
Specifications and dimensions subject to change

Design Features of C&K Smart Card Connectors

C&K Components has a successful track record of manufacturing innovative interconnect devices with a strong emphasis on reliability and flexibility. As a long established supplier of such devices for Smart Cards in a wide range of applications, we have extensive experience matching performance with the need to remain cost sensitive. We consider the true cost of the interconnect to be a function not just of price, but also the ease with which the device can be integrated into the customer's production process and its performance in the field. We have built in a number of features which set our products apart, such as:

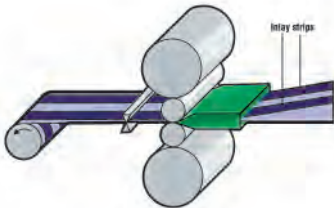

Inlay contact finish

A means of applying precious metal to the contact area utilizing pressure as opposed to conventional plating. We have found this to be the most durable finish available without compromising the electrical performance of the contact. Our research has shown that our inlay finish lasts over ten times as long as standard gold plating. Where we state the life of the precious metal this is intended to be the "worst case" scenario, because the test has been made using the most abrasive smart card that we can find on the market (given that the equipment maker can rarely control which smart cards are used). Note that the inlay finish is silver in color, being an alloy of gold, silver, and palladium.



Card detection switches

As a manufacturer of switches as well as interconnects, we have been able to integrate high performance dome switches into many of our devices. These are variants of switch products which are already in high volume production as stand alone components.



Mechanical robustness

Four metal pegs, to be soldered in PCB metalized holes at the same time than the SMT terminals, have been designed on the smart card connectors in order to increase the resistance of the connector to card insertion force. This participates to the life time and to the overload resistance.

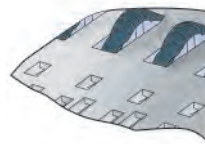

Contact design

The geometry of the contact has an important bearing on its electrical performance. Our contacts are designed to give an efficient wiping action and to maximize the stress between contact and card, thus minimizing the contact resistance. The "spooned" contact area is also shaped so as to protect it from damage during card insertion.



PCI (security standard for POS applications)

Two levels of PCI compatibility level are available:

PCI ready:

Specific features are designed in the connector in order to ease the integration of security devices around and below the connector.

PCI:





Additional accessories are integrated on the connector in order to avoid access to the data contacts and to detect any connection attempt.

Materials

The contact material has been chosen because of its resistance to atmospheric pollution, solderability and performance over time in giving a consistent normal force. Since all of our new interconnects are designed for surface mounting, the plastic materials used must withstand high temperature soldering processes without deforming or adversely affecting performance.



FULL SIZE CARD CONNECTORS

| | | | | |
|---|---|---|--|--|
|  |  |  |  | |
| Series | CCM01 | CCM02 | CCM04 | |
| Applications | Professional | Professional | Consumer/Professional | |
| PCI* | PCI ready | PCI/PCI ready | | |
| EMV | • | • | | |
| Insertion force | 40N max | 40N max | 10N max | |
| Overload | 250N | 180N | 40N | |
| Card guide | • | • | | |
| Sealed switch | • | • | | |
| Operating life | 100,000 cycles | 500,000 cycles | >50,000 cycles | |
| Contact plating | inlay | inlay | gold | |
| Number of contacts | 8 | 8 | 6 or 8 | |
| Contact type | friction | friction | friction/vandal proof | |
| Page No. | 7 | 12 | 17 | |

SIM / SAM CARD CONNECTORS

| | | | |
|---|---|---|--|
|  |  |  | |
| Series | CCM03 | CCM04 | |
| Applications | Consumer/Professional | Consumer/Professional | |
| Cover | hinged / fixed | hinged / fixed | |
| Operating life | 10,000 to 50,000 cycles | 30,000 cycles | |
| Sealed switch | • | | |
| Contact plating | inlay / gold | inlay / gold | |
| Card end travel switch | with / without | without | |
| Number of contacts | 6 or 8 | 6 or 8 | |
| Page No. | 24 | 43 | |

* PCI

PCI ready: specific features are designed into the connector in order to ease the integration of security devices around and below the connector.

PCI: specific additional accessories are integrated on the connector in order to avoid access to the data contacts and to detect any connection attempt.

The logo for C&K, featuring the letters 'C' and 'K' in a bold, red, sans-serif font, with an ampersand '&' in a smaller, black font between them. The logo is set against a white circular background that is part of a larger red graphic element.

Full Size Cards



Features

- Operating life up to 100,000 cycles
- 40N card insertion force
- EMV
- PCI ready
- Card detection sealed switch

Typical Applications

- Transaction
- Identification
- POS



Mechanical

| | |
|--------------------------|--|
| Number of Contacts | 8 |
| Mechanical life | Up to 500,000 cycles |
| Card insertion force | 40N max. |
| Card extraction force | 1 N min / 10 N max |
| Contact force | 0,2N / 0,50 N max |
| Card detection switch | 0,8 N max for actuation (end travel switch actuation force actuates when card is 0,9mm from card stop) |
| | 1,8 N max for complete depression |
| Vibration Frequency | 10 to 500 Hz. Acceleration 50m/s ² Duration 6 hours - amplitude 0,35mm |
| Max elect. discontinuity | 1µs |
| Shock | Peak value 500 m/s ² – Duration 11 ms 3 shocks in each direction of each axis |

Packaging

Tray 30 parts / Cartons 300 parts
Reel 200 parts / Cartons 1,000 parts

Soldering

Compatible with lead free SMT reflow soldering process

Contact Electrical Data

| | |
|-----------------------|---------------------|
| Insulation resistance | 1,000 MΩ min |
| Resistance | 100 mΩ max |
| Current rating | 10 µA min / 1 A max |
| Dielectric strength | 750 Vrms min |

Switch Electrical Data

| | |
|-----------------------|----------------------|
| Card detection switch | Normally open |
| Contact resistance | 100 mΩ max |
| Dielectric strength | 250 Vrms min |
| Current rating | 1 mA min / 10 mA max |
| Maximum power | 0.2 VA |

Environmental Data

| | |
|-----------------------|------------------------------------|
| Operating temperature | -40°C to +85°C |
| Damp heat | IEC 512 test number 11c (10 days) |
| Salt mist | IEC 512 test number 11f (96 hours) |
| Card detection switch | Sealed against dust |
| RoHS compliant | |

| Designation | Termination | Operating Life | Card Insertion Force |
|---------------|-------------|----------------|----------------------|
| CCM01-2027LFT | SMT | 100,000 cycles | 40N |

CCM01 MK2 Series

CCM01-2027 LFT

Full Size

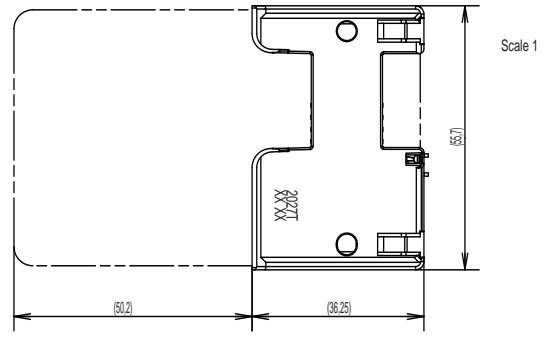
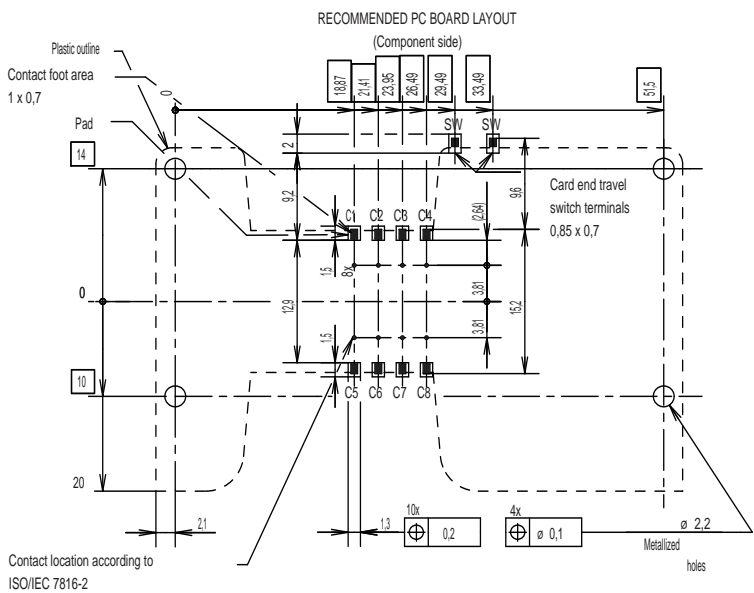
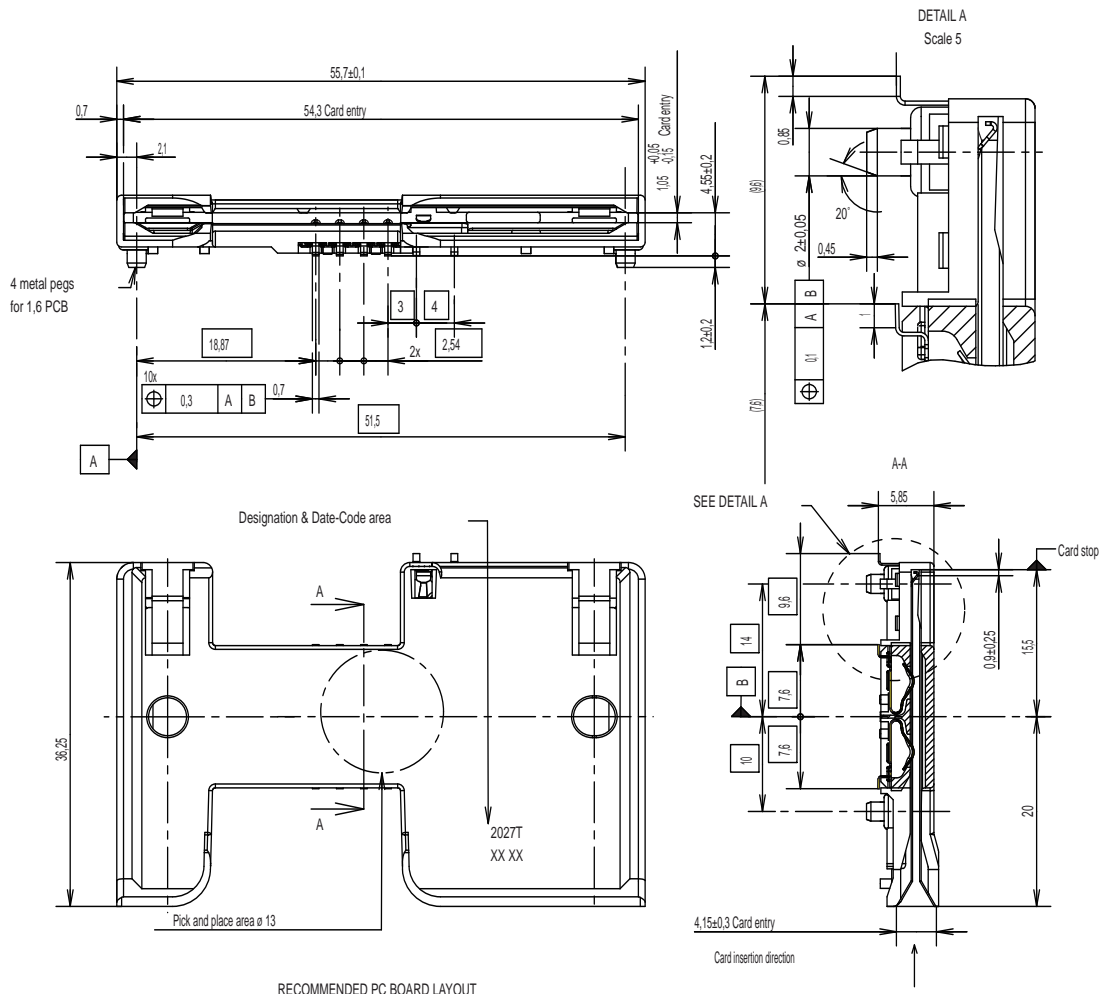

Dimensions are shown in mm
Specifications and dimensions subject to change

www.ck-components.com

CCM01 MK5 Series

Features/Benefits

- Operating life 500,000 cycles
- Low profile 4 mm and 3.2 mm height
- PCI ready
- Card detection sealed switch

Typical Applications

- Transaction
- Identification
- POS
- MPOS



Full Size

Mechanical

| | |
|------------------------|----------------------|
| NUMBER OF CONTACTS: | 8 |
| MECHANICAL LIFE: | 500,000 cycles |
| CARD INSERTION FORCE: | 10 N max. |
| CARD EXTRACTION FORCE: | 1 N min. / 10 N max. |
| CONTACT FORCE: | 0,2 N / 0,60 N max. |

Packaging

Tray 25 parts or Reel 350 parts

Soldering

Compatible with lead free SMT reflow soldering process

Contact Electrical Data

| | |
|------------------------|---------------------------|
| INSULATION RESISTANCE: | 1,000 M Ω min. |
| CONTACT RESISTANCE: | 100 m Ω max. |
| CURRENT RATING: | 10 μ A min. / 1A max. |
| DIELECTRIC STRENGTH: | 750 Vrms min. |

Switch Electrical Data

| | |
|------------------------|------------------------|
| CARD DETECTION SWITCH: | Normally open |
| CONTACT RESISTANCE: | 100 m Ω max. |
| DIELECTRIC STRENGTH: | 250 Vrms min. |
| CURRENT RATING: | 1 mA min. / 10 mA max. |
| MAXIMUM POWER: | 0.2 VA |

Environmental Data

| | |
|------------------------|---------------------|
| OPERATING TEMPERATURE: | -40°C to + 85°C |
| CARD DETECTION SWITCH: | Sealed against dust |
| RoHS compliant | |

How To Order

To order, simply select desired option from each category and place in the appropriate box. For additional options not shown in catalog, consult our Customer Service Center.

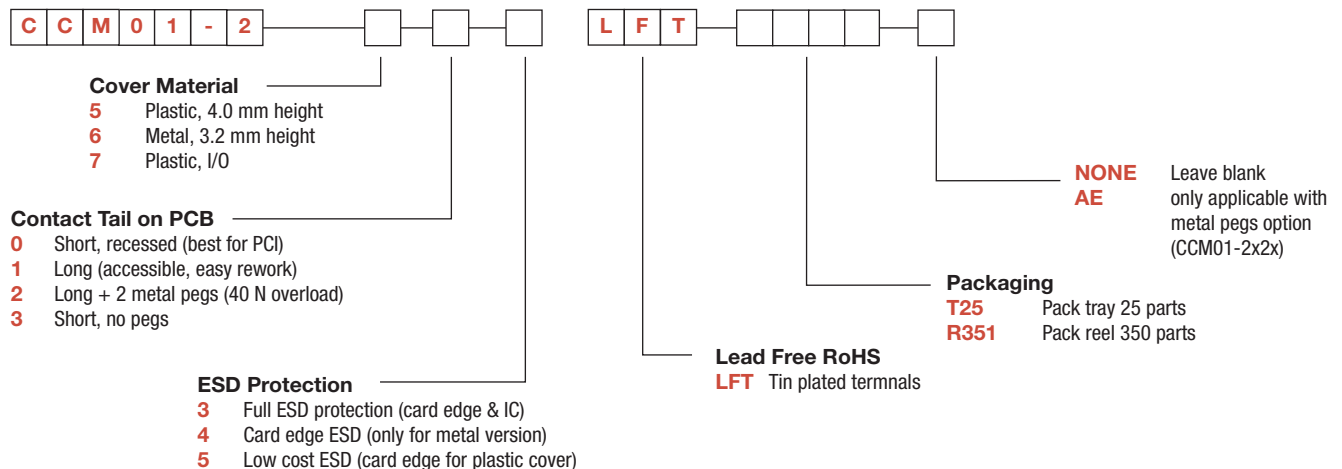

Dimensions are shown in mm
Specifications and dimensions subject to change

www.ck-components.com

CCM01 MK5 Series

CCM01-2604 LFT T25 Metal cover, short tails

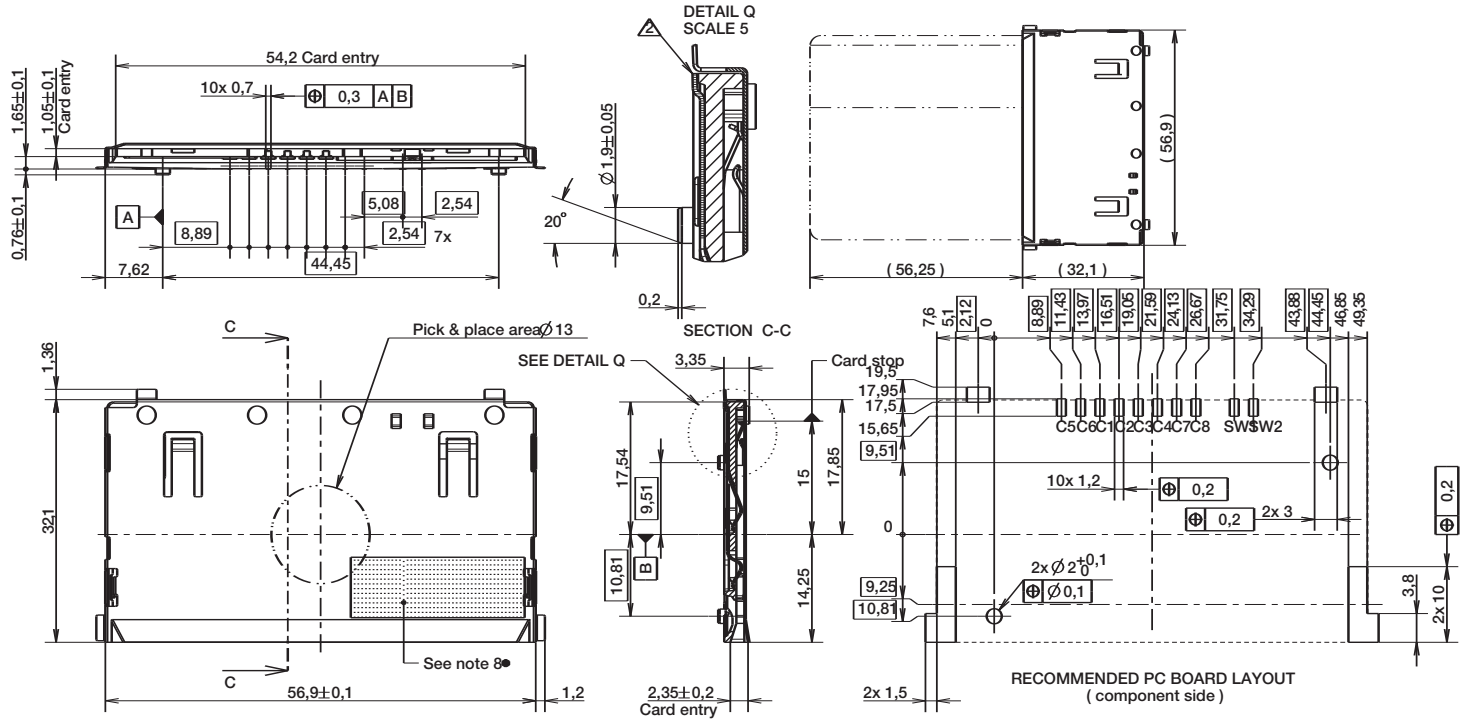

CCM01-2513 LFT T25 Plastic cover, long tails, full ESD protection

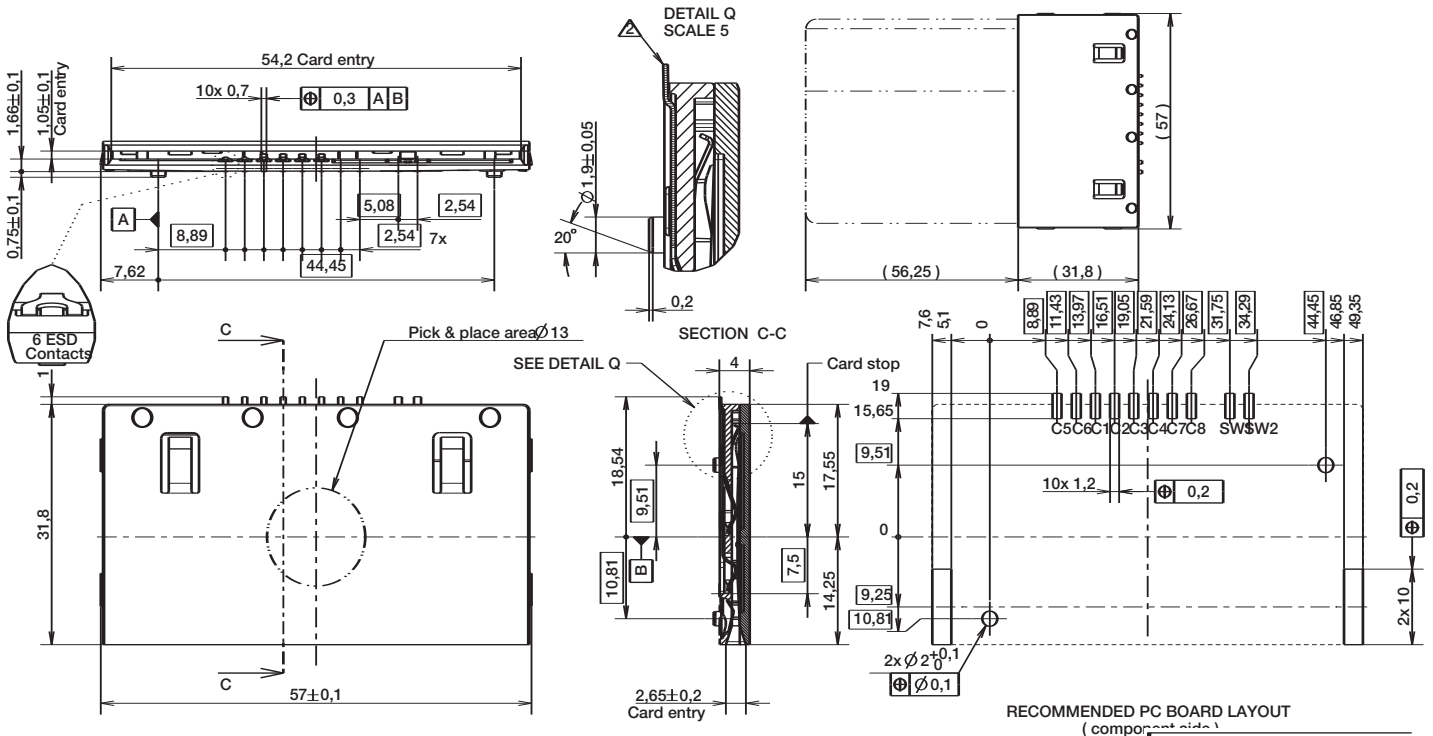

First Angle Projection
 Dimensions are shown in mm
 Specifications and dimensions subject to change

CCM01 MK5 Series

CCM01-2523 LFT T25 Plastic cover, long tails, metal pegs

Full Size

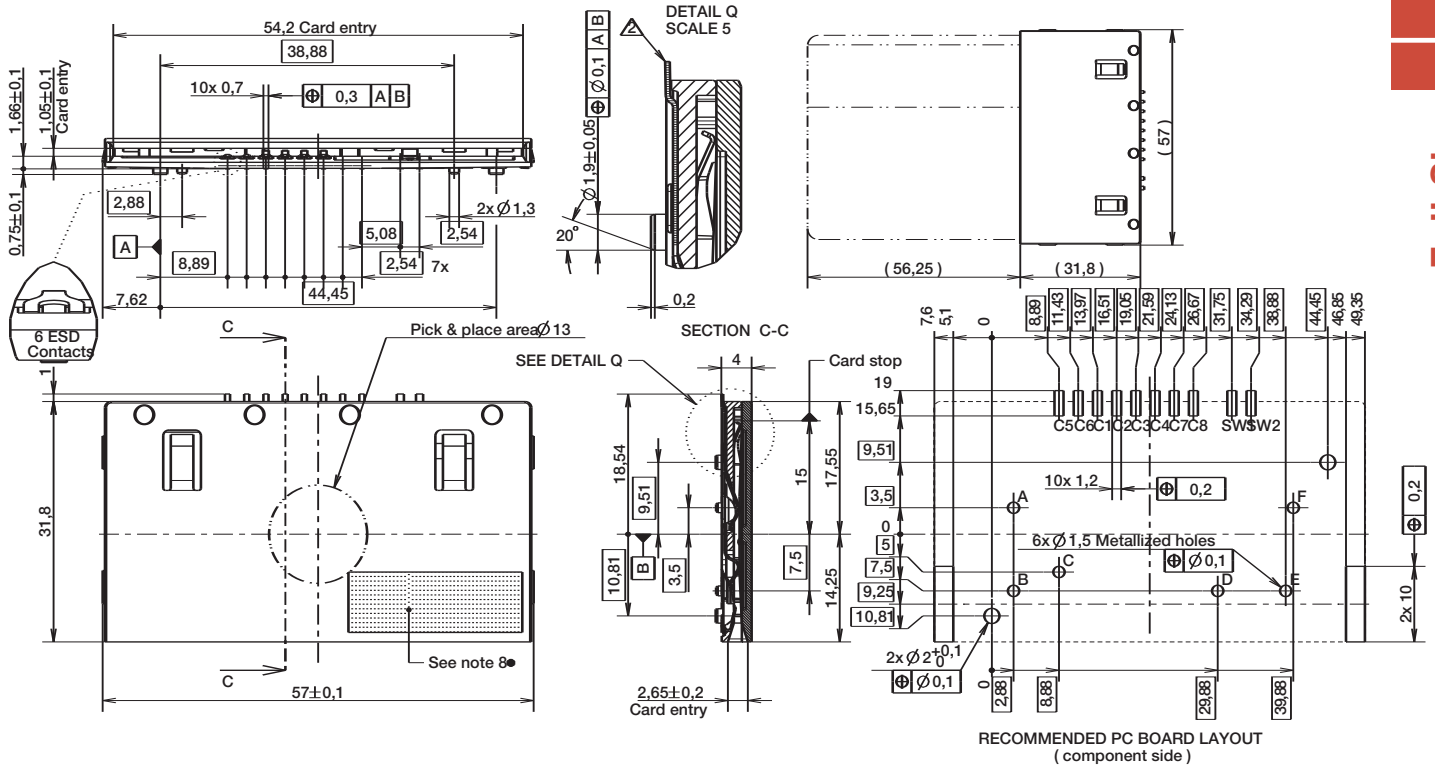

CCM01-2614 LFT T25 Metal cover, long tails, no ESD protection

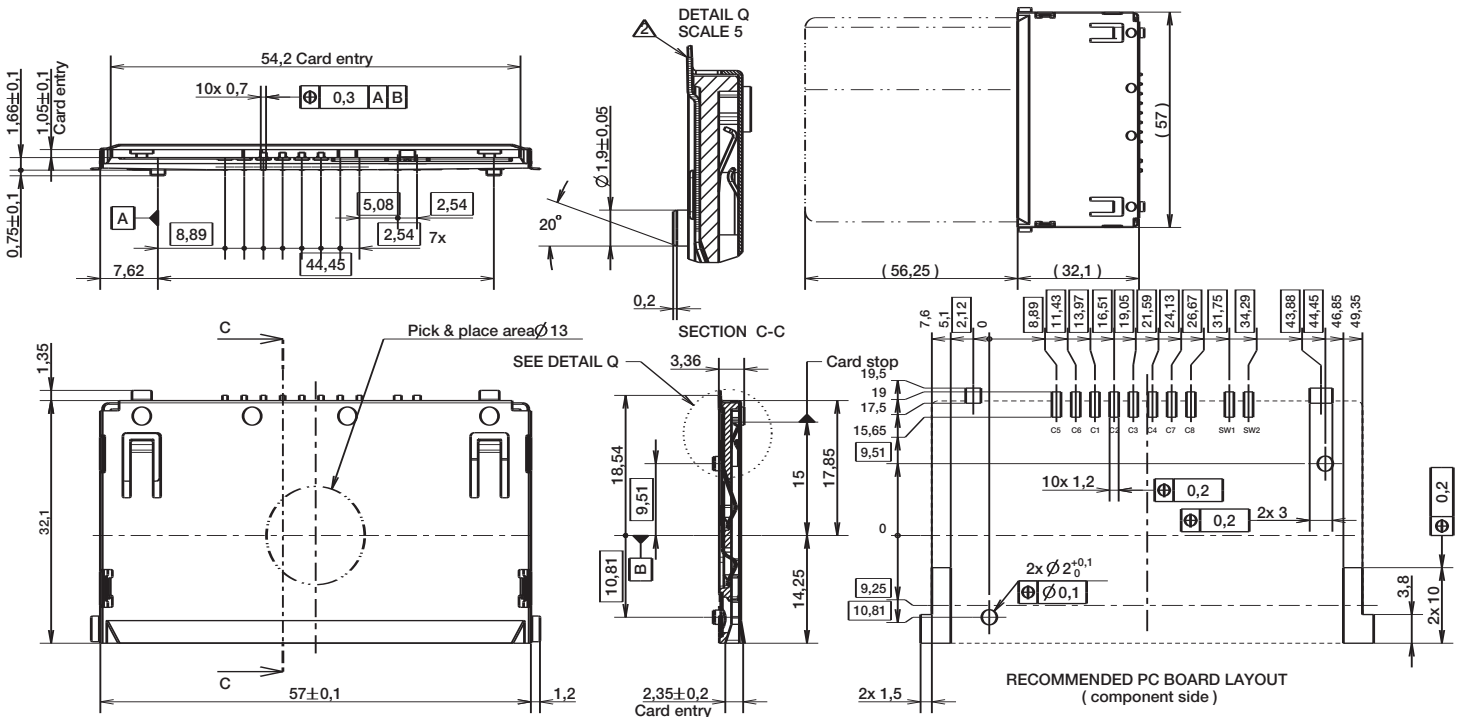

Dimensions are shown in mm
Specifications and dimensions subject to change

www.ck-components.com

CCM02 MK2 Series



Features

- Operating life 500,000 cycles
- Insertion force 40N
- EMV
- PCI & PCI ready
- Card detection sealed switch

Typical Applications

- Transaction
- Identification
- POS

Mechanical

| | |
|--------------------------|---|
| Number of Contacts | 8 |
| Mechanical life | 500,000 cycles min |
| Card insertion force | 10N to 40N |
| Card extraction force | 1N min / 10N max |
| Contact force | 0,2N / 0,50N max |
| Card detection switch | 0,8 N max for actuation (end travel switch actuation force actuates when card is 0,9mm from card stop) 1,8 N max for complete depression |
| Vibration Frequency | 10 to 500 Hz. Acceleration 50m/s ² Duration 6 hours - amplitude 0,35mm |
| Max elect. discontinuity | 1µs |
| Shock | Peak value 500 m/s ² – Duration 11 ms 3 shocks in each direction of each axis |

Packaging

Tray 30 parts / Cartons 300 parts
Reel 120 parts

Soldering

Compatible with lead free reflow soldering process
For version with security cover, please contact Customer Service for soldering recommendations.

Contact Electrical Data

| | |
|-----------------------|---------------------|
| Insulation resistance | 1,000 MΩ min |
| Resistance | 100 mΩ max |
| Current rating | 10 µA min / 1 A max |
| Dielectric strength | 750 Vrms min |

Switch Electrical Data

| | |
|-----------------------|----------------------|
| Card detection switch | Normally open |
| Contact resistance | 100 mΩ max |
| Dielectric strength | 250 Vrms min |
| Current rating | 1 mA min / 10 mA max |
| Maximum power | 0.2 VA |

Environmental Data

| | |
|-----------------------|------------------------------------|
| Operating temperature | -40°C to +85°C |
| Damp heat | IEC 512 test number 11c (10 days) |
| Salt mist | IEC 512 test number 11f (96 hours) |
| Card detection switch | Sealed against dust |
| RoHS compliant | |

| Designation | Termination | Contact Type | PCI Features | | Total Height (mm) | Dimension | PCB version |
|---------------|-------------|--------------|--------------|----------------|-------------------|-------------|--------------|
| | | | I/O Protect | Security Cover | | | |
| CCM02-2503LFT | THT | landing | | | 6,25 | 38,5 X 55,6 | 4 clips |
| CCM02-2504LFT | SMT | landing | | | 6,25 | 38,5 X 55,6 | 4 clips |
| CCM02-F503LFT | THT | friction | | | 6,25 | 38,5 X 55,6 | 4 clips |
| CCM02-F504LFT | SMT | friction | | | 6,25 | 38,5 X 55,6 | 4 clips |
| CCM02-F844LFT | SMT | friction | Yes | Yes | 6,6 | 40,5 X 58 | 4 metal pegs |

PCI: I/O Protect

Definition

Special accessory in order to avoid and detect frontal access to data contact. It is electrically connected to the PCB through spring finger contacts.

Process

It must be in open position during the reflow soldering of the connector and has to be locked in closed position after soldering.



I/O Protect locking tool

C&K is proposing a manual tool to lock the I/O protect accessory after soldering.
Ordering code: C-CM02-E50

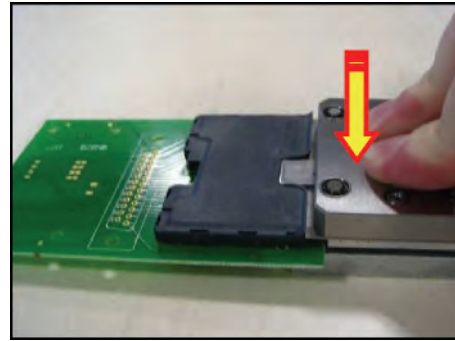
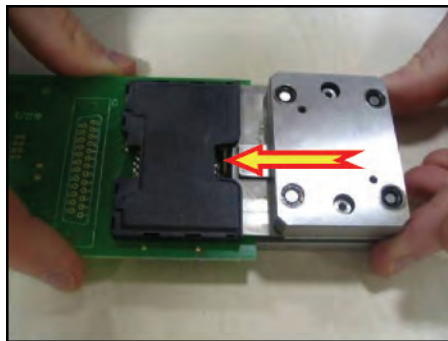

PCI: Security Cover



Definition

It is a multilayer cover placed over the connector to avoid and detect data contact access, especially from the top. It is connected to the PCB through 6 SMT terminals that are soldered at the same time as the other smart card terminals.

Process

Please contact your Sales Representative for advice and recommendations about soldering this version.

CCM02 MK2 Series

CCM02-2503 LFT / CCM02-F503 LFT

Full Size

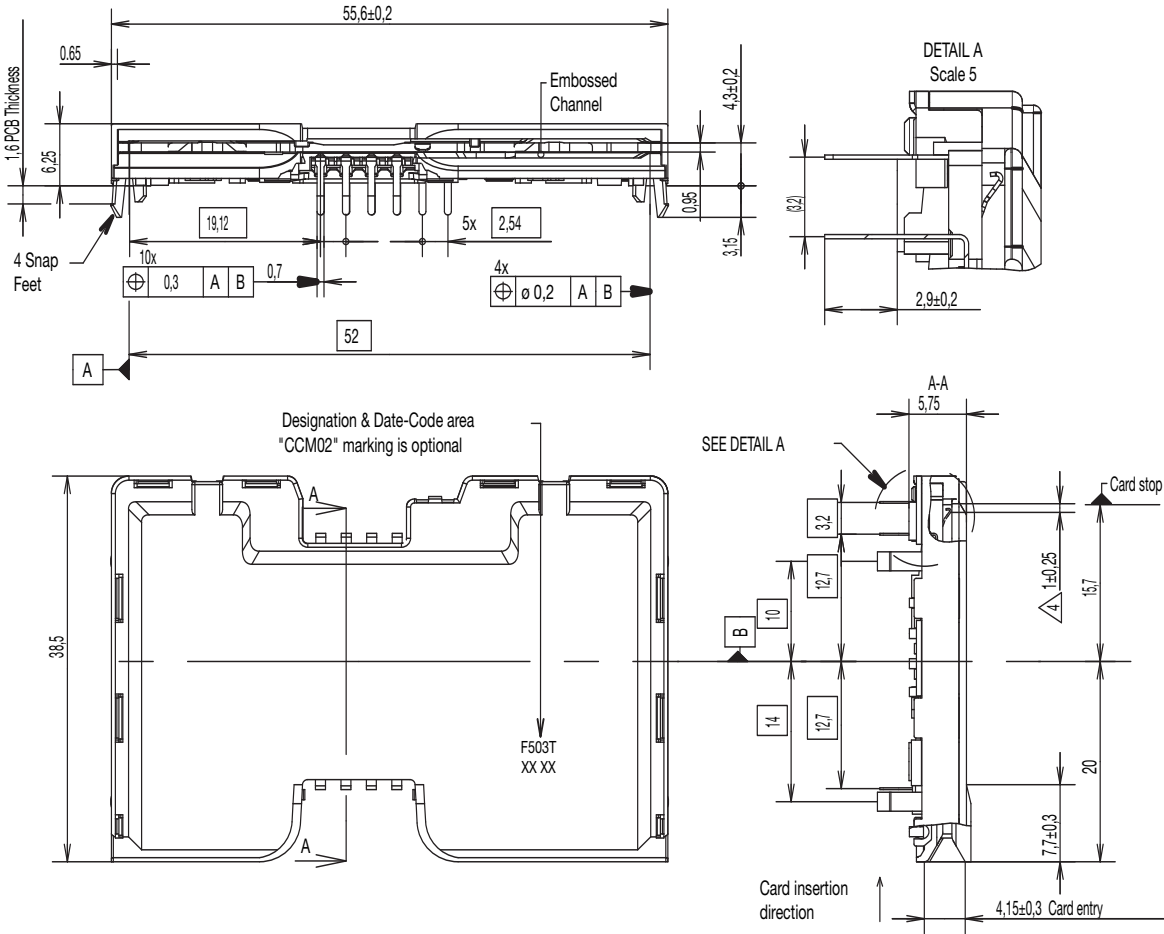

RECOMMENDED PC BOARD LAYOUT
(Component side)

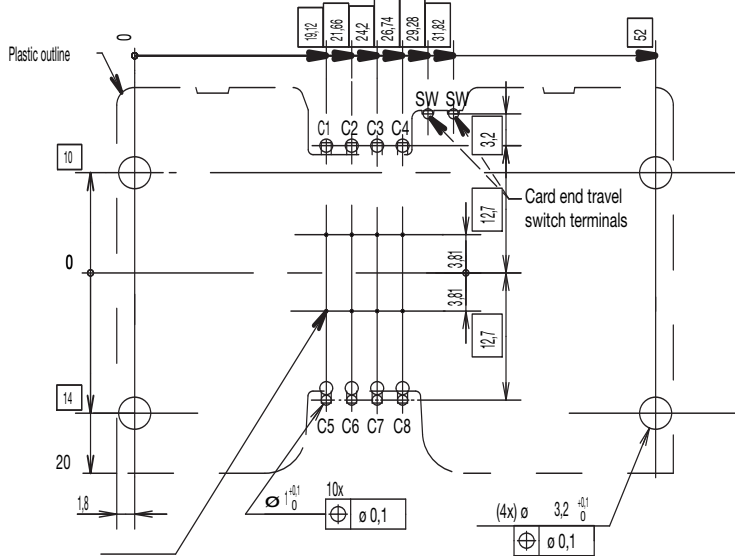

Contact location according to ISO/IEC 7816-2

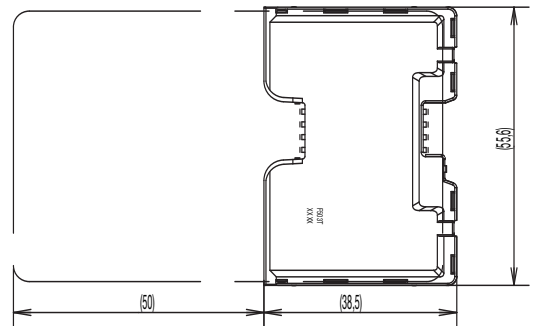

First Angle Projection

Dimensions are shown in mm
Specifications and dimensions subject to change

www.ck-components.com



CCM02 MK2 Series

CCM02-2504 LFT / CCM02-F504 LFT

Full Size

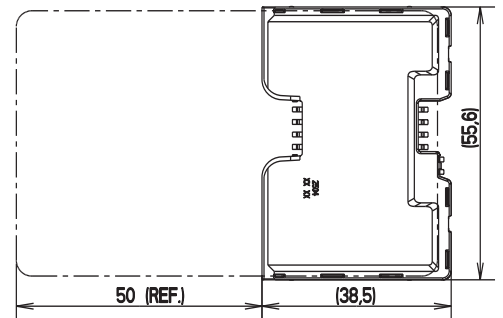
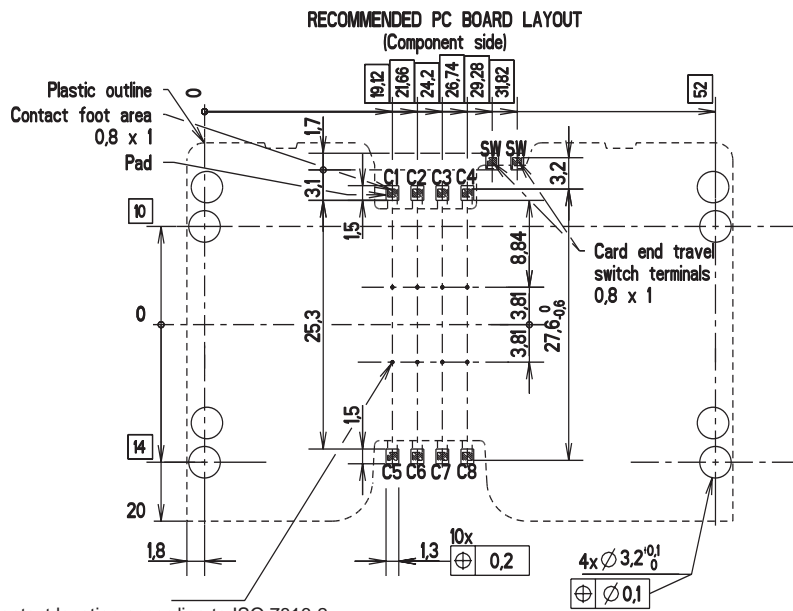
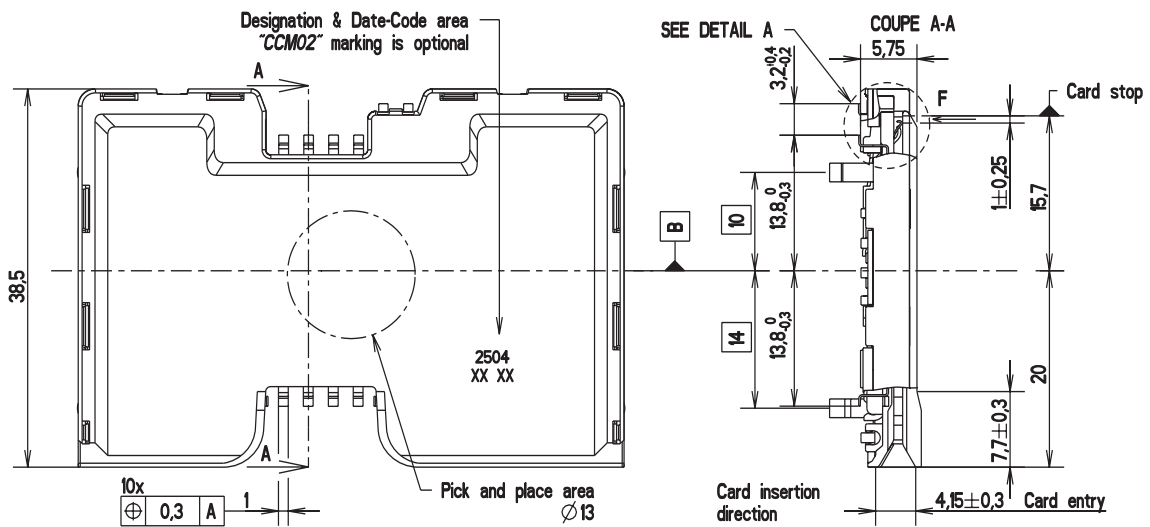
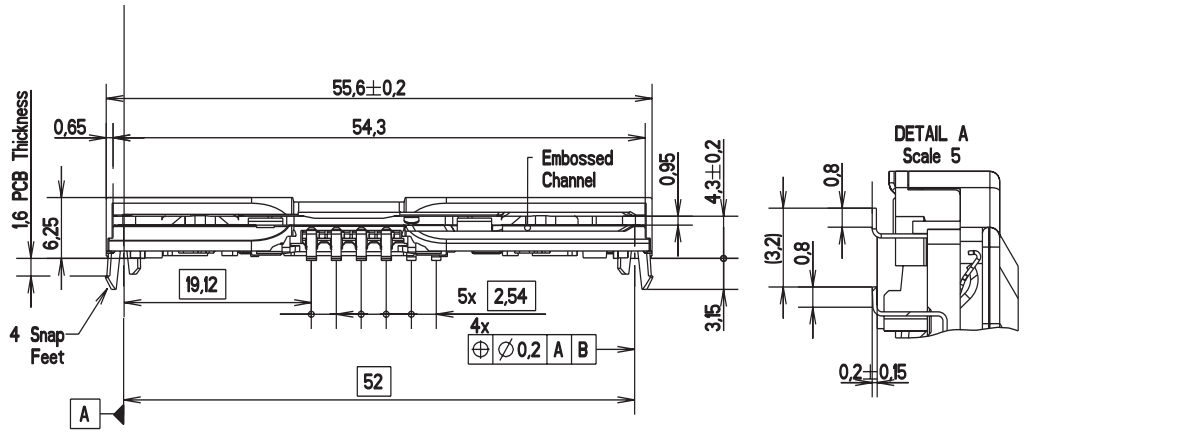

Scale 1

Contact location according to ISO 7816-2



Dimensions are shown in mm
Specifications and dimensions subject to change

www.ck-components.com

Features

- ID1 full size card acceptance
- Card detection sealed switch
- Compatible with pick and place and lead free soldering

Typical Applications

- Transaction
- POS
- Identification



Mechanical

| | |
|--------------------------|--|
| Number of contacts | 6 or 8 |
| Mechanical life | 50,000 cycles |
| Card insertion force | 10N max |
| Card extraction force | 1N min / 10N max |
| Contact force | 0,4N to 0,7N |
| Card detection switch | 0,8 N max for actuation (end travel switch actuation force actuates when card is 0,9mm from card stop) |
| | 1,8 N max for complete depression |
| Vibration Frequency | 10 to 500 Hz. Acceleration 50m/s ² Duration 6 hours - amplitude 0,35mm |
| Shock | Peak value 500 m/s ² – Duration 11 ms 3 shocks in each direction of each axis |
| Max elect. discontinuity | 1µs |

Packaging

See table below

Soldering Process

Compatible with lead free SMT reflow soldering process

Contact Electrical Data

| | |
|------------------------|---------------------|
| Insulation resistance | 1000 MΩ min |
| Contact resistance max | 100 mΩ max |
| Switching current | 10 µA min / 1 A max |
| Dielectric strength | 750 Vrms min |

Switch Electrical Data

| | |
|--------------------------|----------------------|
| Card detection switch | Normally open |
| Rc card detection switch | 100 mΩ max |
| Dielectric strength | 250 Vrms min |
| Switch current rating | 1 mA min / 10 mA max |
| Maximum switch power | 0.2 VA |

Environmental Data

| | |
|-----------------------|------------------------------------|
| Operating temperature | -40°C to +85°C |
| Salt mist | IEC 512 test number 11f (96 hours) |
| Damp heat | IEC 512 test number 11c (10 days) |
| Card detection switch | Sealed against dust |
| RoHS compliant | |

| Designation | Housing Type | # of Contacts | Contact Force | Total Height (mm) | Total Dim. (mm) | Packaging |
|---------------|--------------|---------------|---------------|-------------------|-----------------|--------------------|
| CCM04-5427LFT | standard | 8 | 0,4N to 0,7N | 2,65 | 18,75 X 25 | reels of 1,000 pcs |
| CCM04-5436LFT | standard | 8 | 0,4N to 0,7N | 0,90 | 18,75 X 26,9 | reels of 1,000 pcs |
| CCM04-5468LFT | stand-off | 8 | 0,4N to 0,7N | 3,5 | 18,75 X 24 | reels of 1,000 pcs |
| CCM04-5454LFT | standard | 8 | 0,4N to 0,7N | 0,90 | 18,75 X 26,9 | reels of 1,000 pcs |
| CCM04-5455LFT | standard | 8 | 0,4N to 0,7N | 0,90 | 18,75 X 26,9 | reels of 1,000 pcs |

CCM04 MK4 Series

CCM04-5427 LFT

Full Size

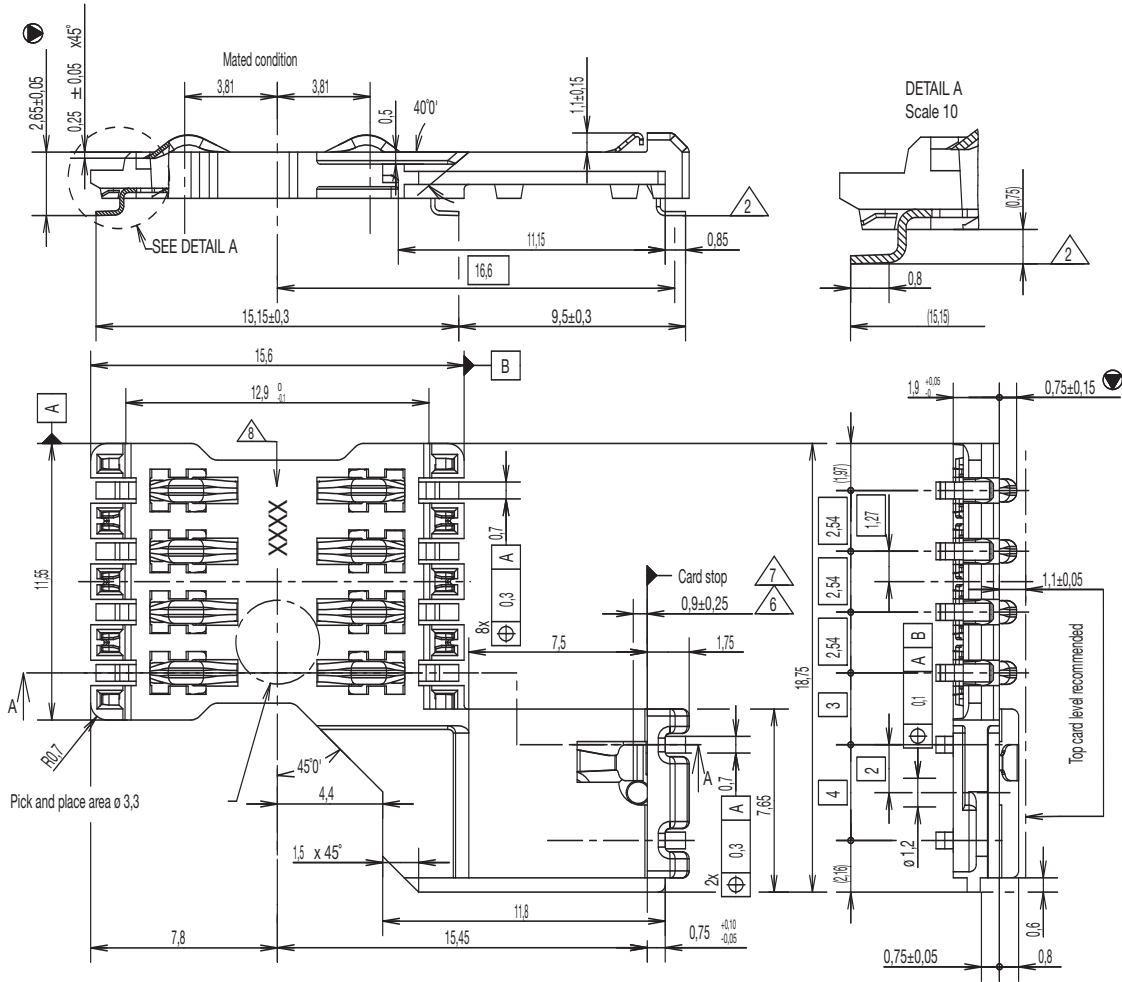

Dimensions are shown in mm
Specifications and dimensions subject to change

www.ck-components.com

CCM04 MK4 Series

CCM04-5468 LFT

Full Size

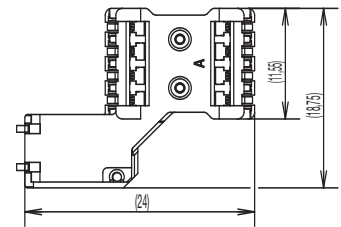
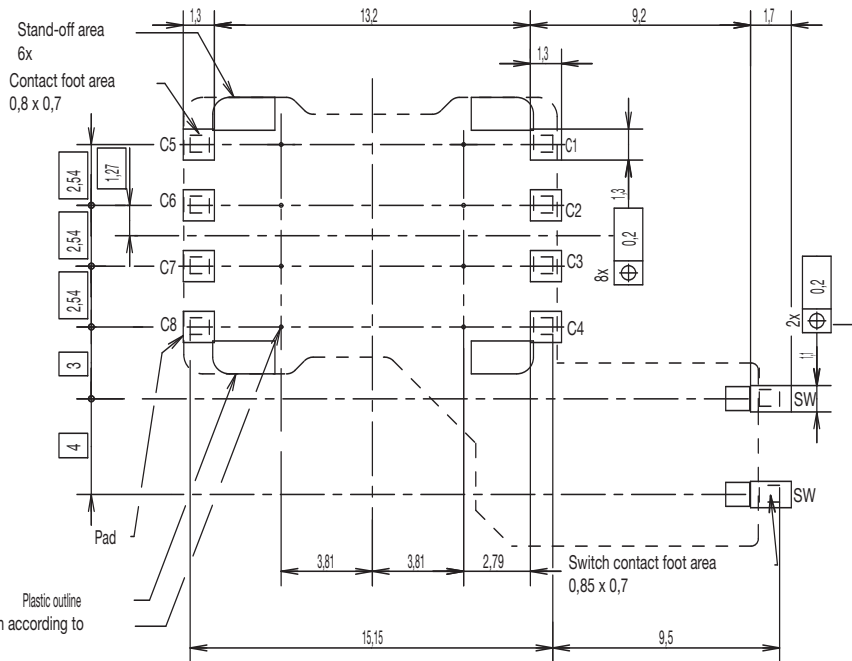
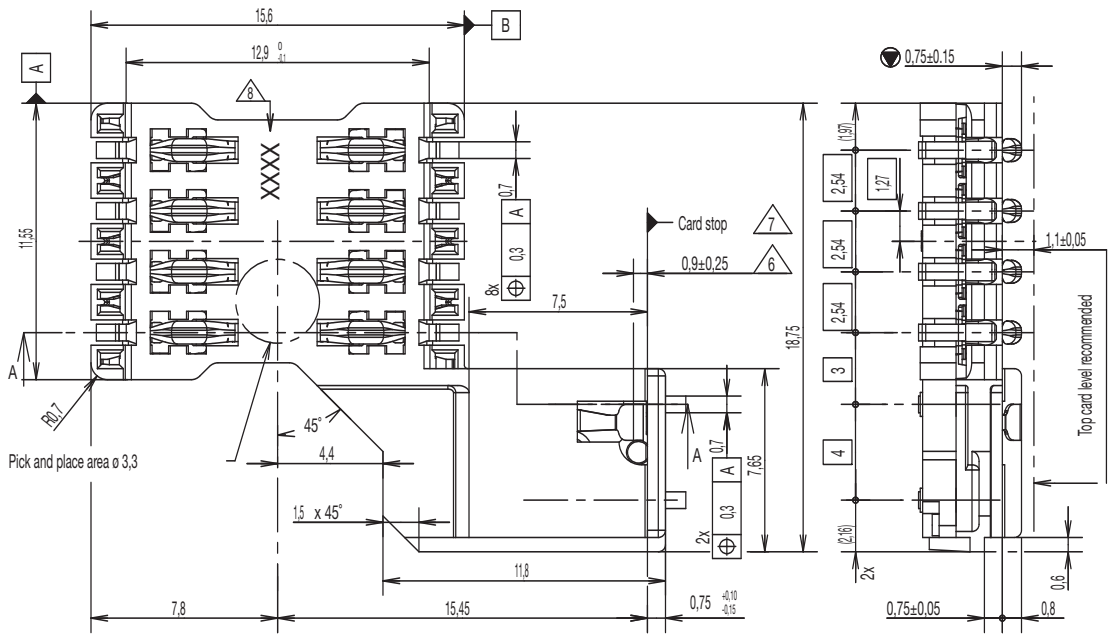
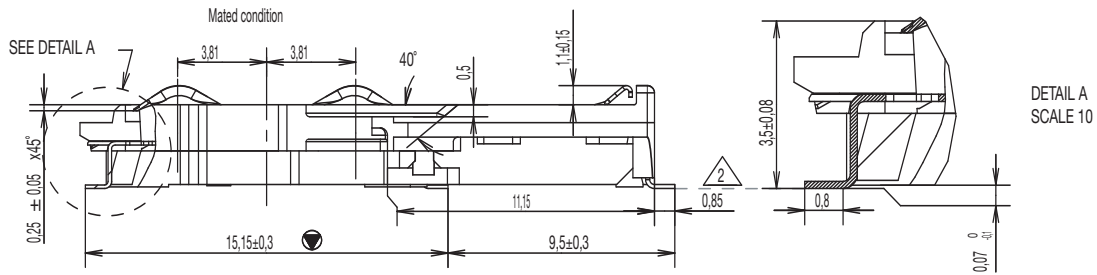

First Angle Projection

Dimensions are shown in mm
Specifications and dimensions subject to change

www.ck-components.com



CCM04 MK4 Series

CCM04-5454 LFT

Full Size

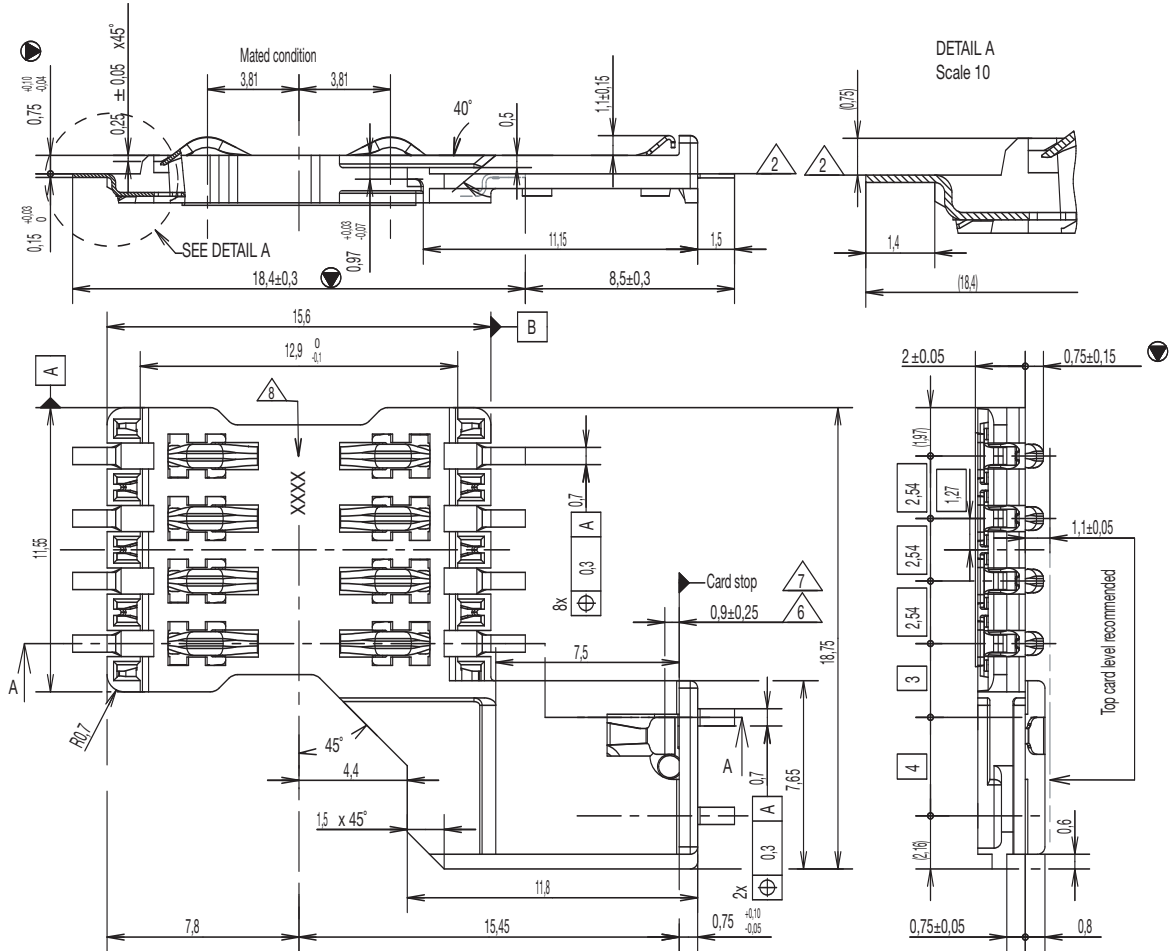

RECOMMENDED PC BOARD LAYOUT
(Component side)
Scale 2,5

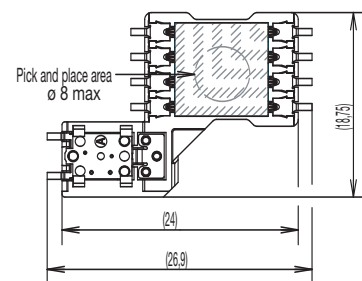
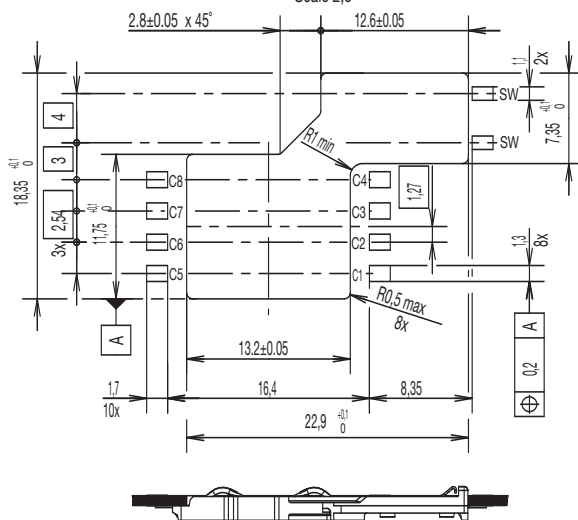

Dimensions are shown in mm
Specifications and dimensions subject to change

www.ck-components.com

CCM04 MK4 Series

CCM04-5455 LFT

Full Size

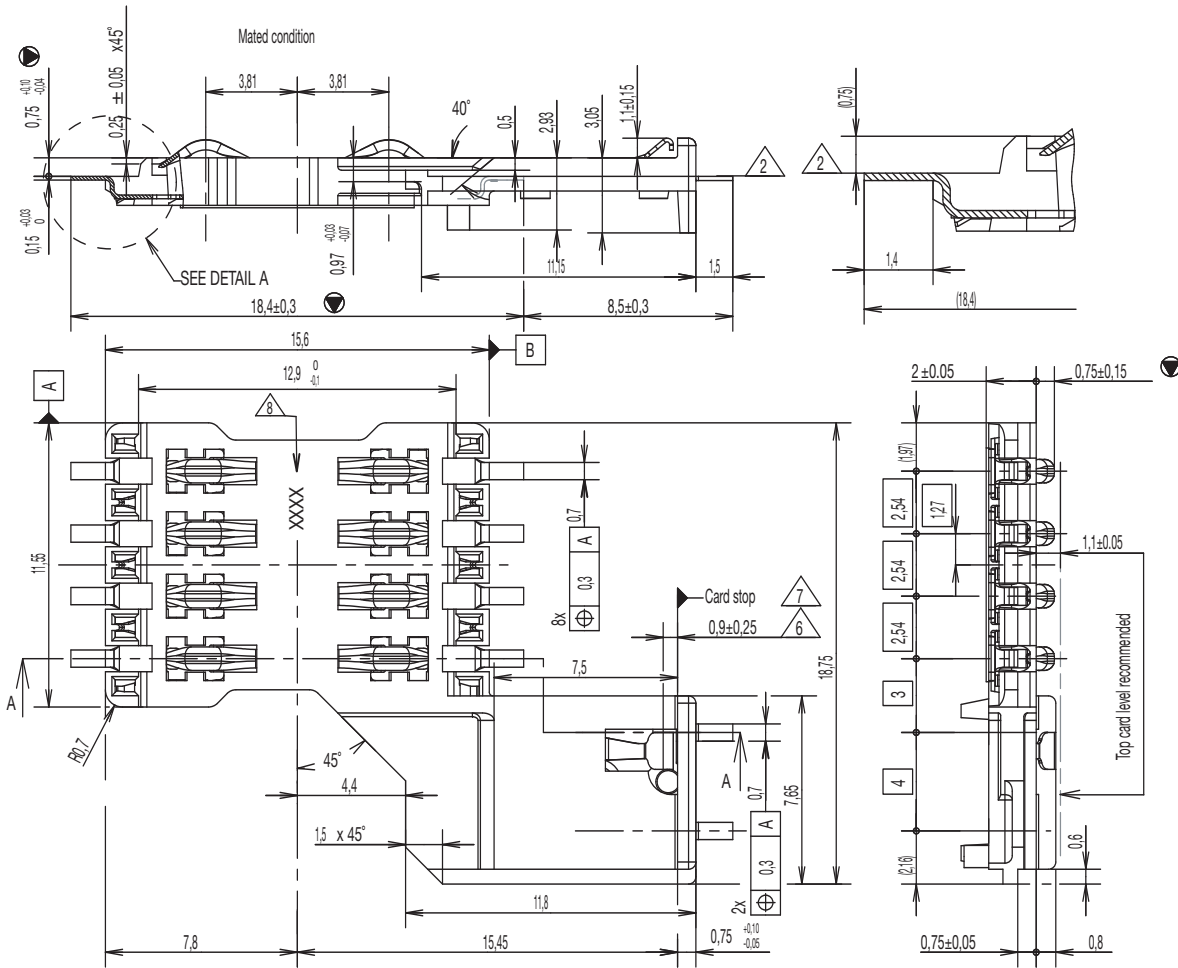

RECOMMENDED PC BOARD LAYOUT
(Component side)
Scale 2,5

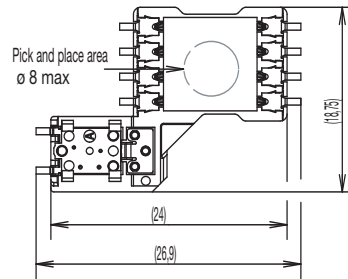
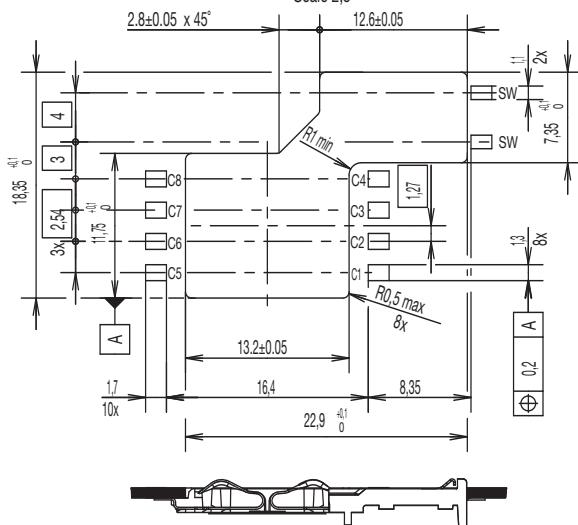

First Angle Projection

Dimensions are shown in mm
Specifications and dimensions subject to change

www.ck-components.com



C&K[®]



SIM / SAM Cards



CCM03 MK2 Series



Features

- SIM/SAM card acceptance
- Hinged and fixed covers
- Compatible with pick and place and lead free soldering

Typical Applications

- Handheld products
- Identification
- POS
- Automotive

Mechanical

| | |
|-------------------------------|--|
| Number of Contacts | 6 or 8 |
| Mechanical life, hinged cover | 10,000 cycles min |
| Mechanical life, fixed cover | 50,000 cycles |
| Card insertion force | Hinged cover: 1N max Fixed cover: 3N max |
| Card extraction force | Hinged cover: 1N max Fixed cover: 0,80N min / 3N max |
| Contact force | 0,25N min / 0,50N max |
| Slide locking force | 2N min / 6N max |
| Vibration Frequency | 1,8N max. for complete depression 10 to 500 Hz. Acceleration 50m/s ² Duration 6 hours - amplitude 0,35 mm |
| Max electrical discontinuity | 1µs |
| Shock | Peak value 500 m/s ² – Duration 11 ms 3 shocks in each direction of each axis |

Switch Electrical Data

| | |
|-----------------------|----------------------|
| Card detection switch | Normally open |
| Contact resistance | 100 mΩ max |
| Dielectric strength | 250 Vrms min |
| Current rating | 1 mA min / 10m A max |
| Maximum power | 0.2 VA |

Environment Data

| | |
|-----------------------|------------------------------------|
| Operating temperature | -40°C to +85°C |
| Damp heat | IEC 512 test number 11c (10 days) |
| Salt mist | IEC 512 test number 11f (96 hours) |
| RoHS compliant | |

Soldering Process

Compatible with lead free SMT soldering process



Contact Electrical Data

| | |
|-----------------------|---------------------|
| Insulation resistance | 1,000 MΩ min |
| Resistance | 100 mΩ max |
| Current rating | 10 µA min / 1 A max |
| Dielectric strength | 750 Vrms min |

| Designation | Contact Plating | Cover | # of Contacts | PCB Version | Card Presence Switch | Operating Life | Total Height (mm) | Dim. (mm) | Packaging |
|---------------|-----------------|--------|---------------|-----------------------|----------------------|----------------|-------------------|--------------|--------------------|
| CCM03-3001LFT | inlay | hinged | 6 | | without | 10,000 | 2,55 | 17,2 x 29,65 | reels of 1,000 pcs |
| CCM03-3002LFT | inlay | hinged | 6 | 2 plastic pegs | without | 10,000 | 2,55 | 17,2 x 29,65 | reels of 1,000 pcs |
| CCM03-3003LFT | inlay | hinged | 8 | | without | 10,000 | 2,55 | 17,2 x 29,65 | reels of 1,000 pcs |
| CCM03-3004LFT | inlay | hinged | 8 | 2 plastic pegs | without | 10,000 | 2,55 | 17,2 x 29,65 | reels of 1,000 pcs |
| CCM03-3009LFT | gold | hinged | 6 | | without | 10,000 | 2,55 | 17,2 x 29,65 | reels of 1,000 pcs |
| CCM03-3010LFT | gold | hinged | 6 | 2 plastic pegs | without | 10,000 | 2,55 | 17,2 x 29,65 | reels of 1,000 pcs |
| CCM03-3011LFT | gold | hinged | 8 | | without | 10,000 | 2,55 | 17,2 x 29,65 | reels of 1,000 pcs |
| CCM03-3012LFT | gold | hinged | 8 | 2 plastic pegs | without | 10,000 | 2,55 | 17,2 x 29,65 | reels of 1,000 pcs |
| CCM03-3013LFT | gold | hinged | 6 | | with | 10,000 | 2,55 | 17,2 x 29,65 | reels of 1,000 pcs |
| CCM03-3512LFT | gold | hinged | 6 | Large soldering pads* | without | 10,000 | 2,55 | 17,2 x 29,65 | reels of 1,000 pcs |
| CCM03-3504LFT | gold | fixed | 8 | | without | 50,000 | 2,85 | 17,2 x 25,5 | reels of 1,000 pcs |
| CCM03-3505LFT | gold | fixed | 6 | | without | 50,000 | 2,85 | 17,2 x 25,5 | reels of 1,000 pcs |
| CCM03-3754LFT | inlay | fixed | 6 | | with | 10,000 | 3,5 | 16,5 x 18,05 | reels of 1,000 pcs |
| CCM03-3760LFT | inlay | fixed | 6 | | without | 10,000 | 3,45 | 16,5 x 15,85 | reels of 1,000 pcs |
| CCM03-3764LFT | inlay | none | 6 | | with | 10,000 | 2,9 | 16,5 x 15,85 | reels of 1,000 pcs |

* Can go through reflow upside down

CCM03 MK2 Series

CCM03-3001 LFT / CCM03-3009 LFT

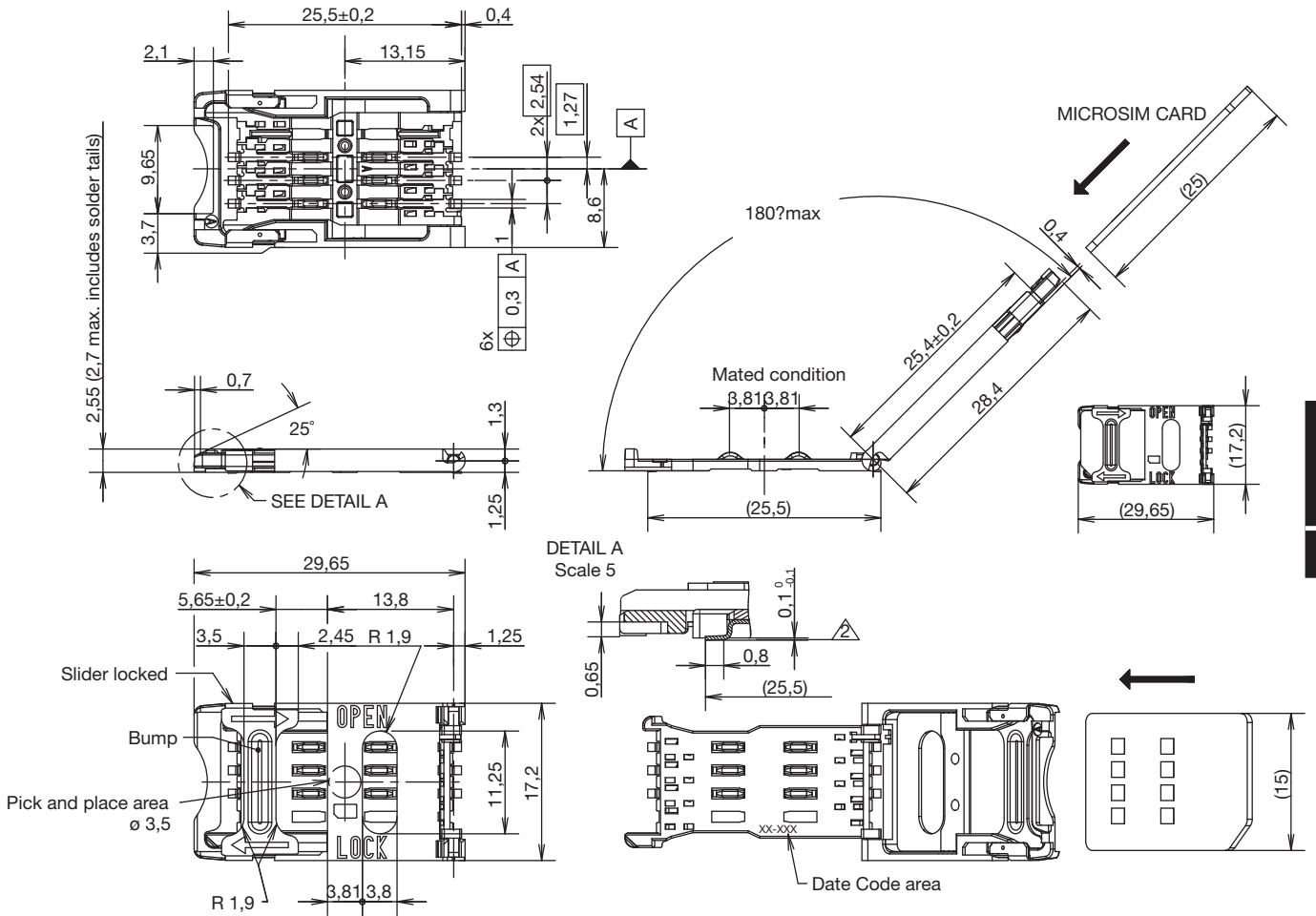

SIM/SAM

RECOMMENDED PC BOARD LAYOUT
(Component side)

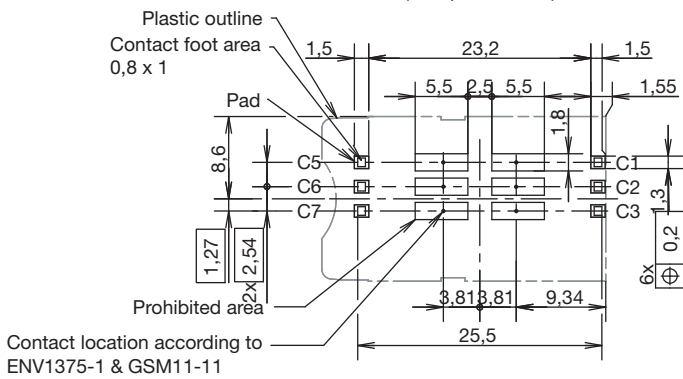

Dimensions are shown in mm
Specifications and dimensions subject to change

www.ck-components.com

CCM03 MK2 Series

CCM03-3003 LFT

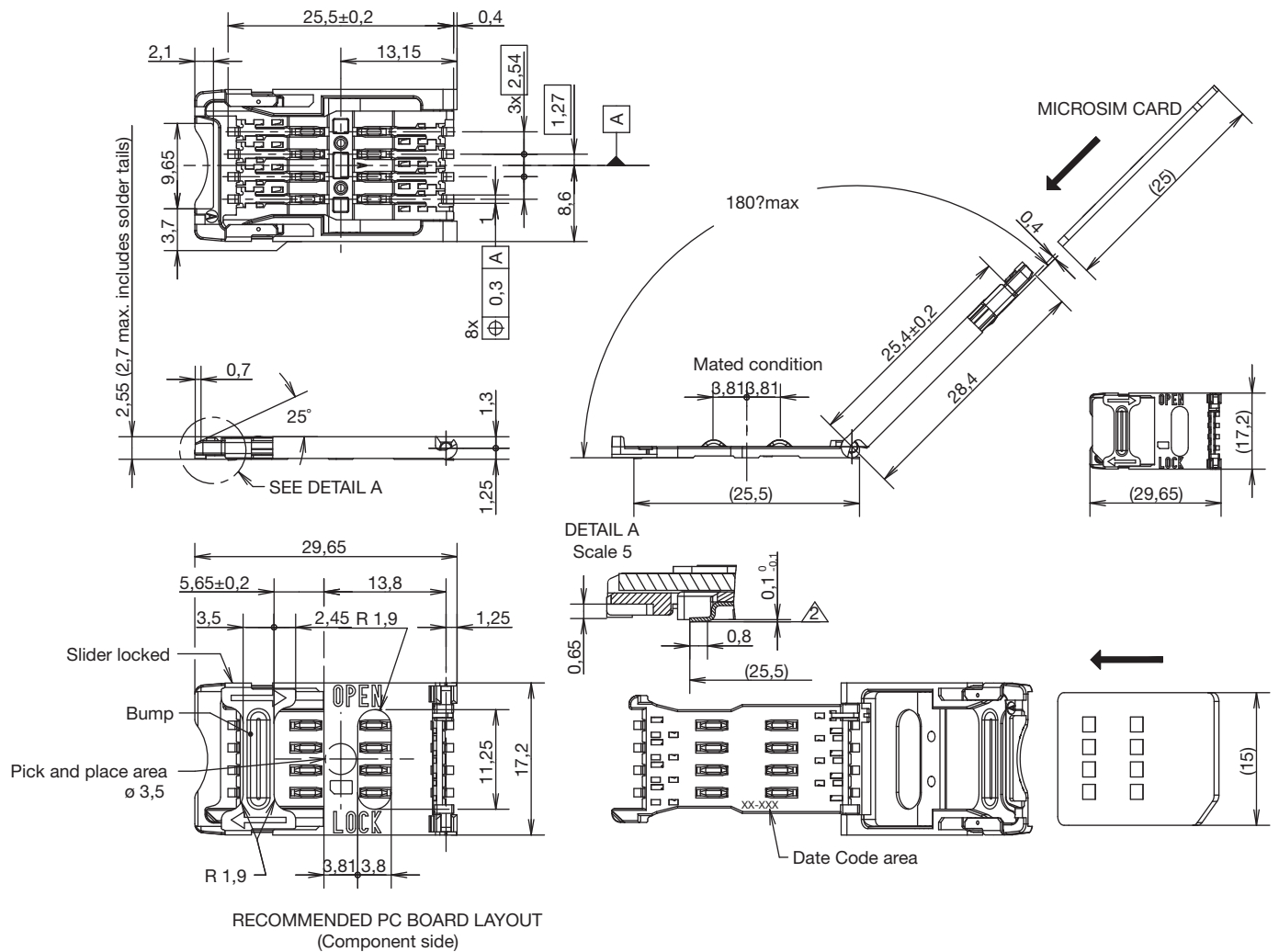

SIM/SAM

Contact location according to ENV1375-1 & GSM11-11



Dimensions are shown in mm
Specifications and dimensions subject to change

www.ck-components.com

CCM03 MK2 Series

CCM03-3004 LFT

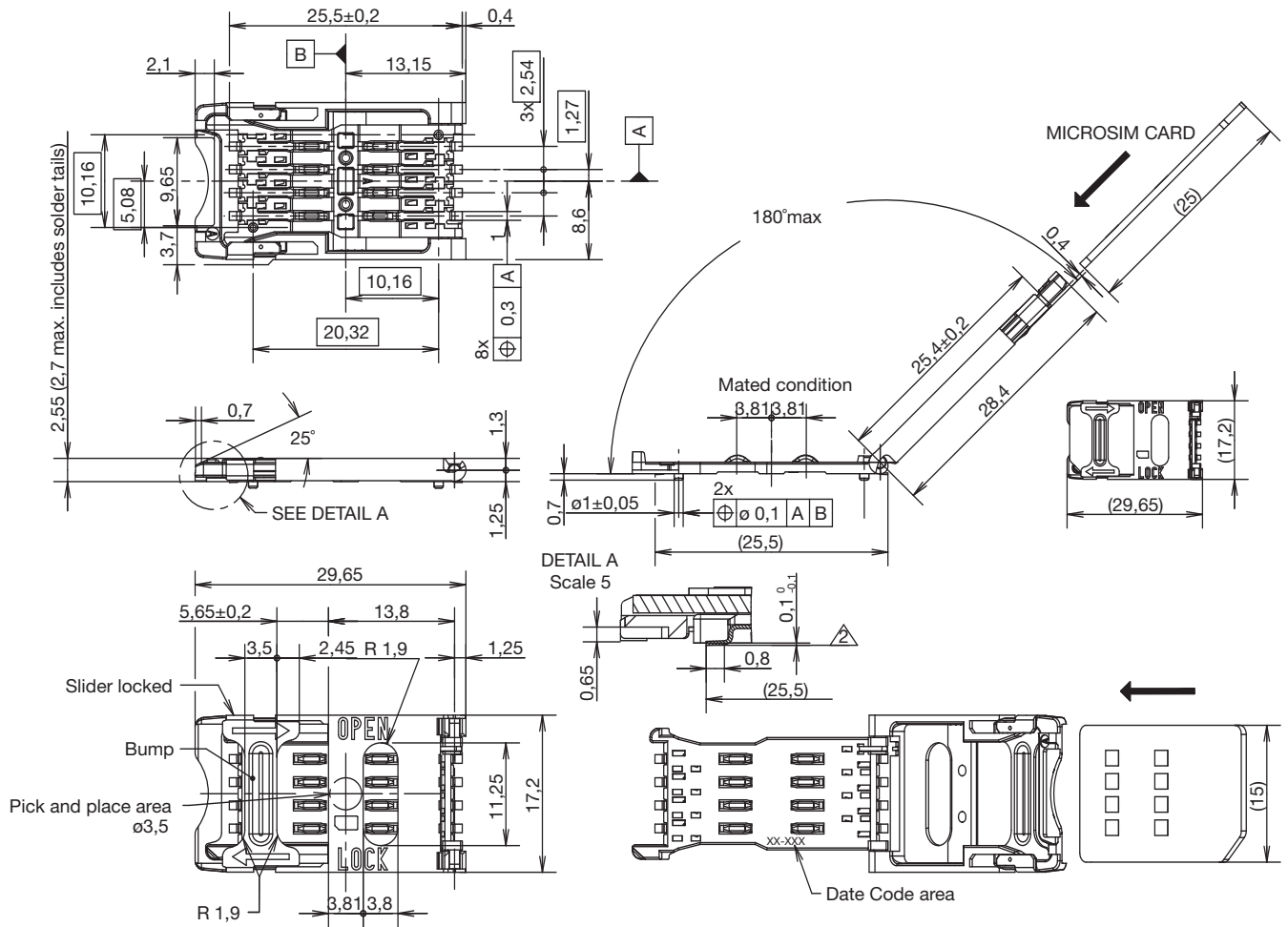

RECOMMENDED PC BOARD LAYOUT
(Component side)

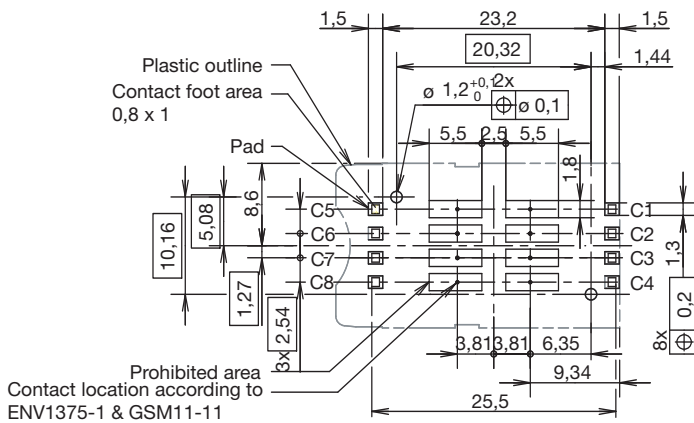

Dimensions are shown in mm
Specifications and dimensions subject to change

www.ck-components.com

SIM/SAM



CCM03 MK2 Series

CCM03-3011 LFT

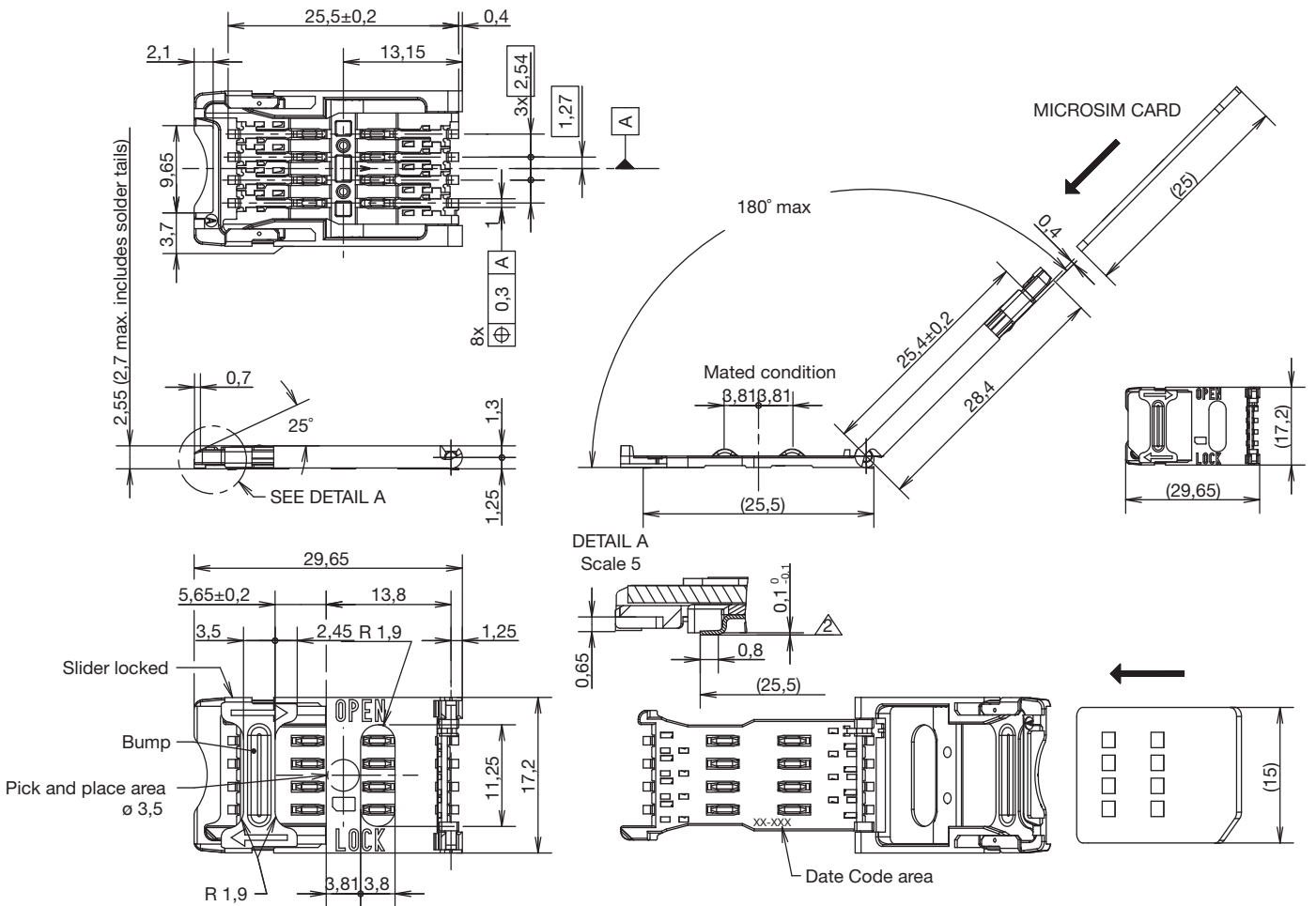

RECOMMENDED PC BOARD LAYOUT (Component side)

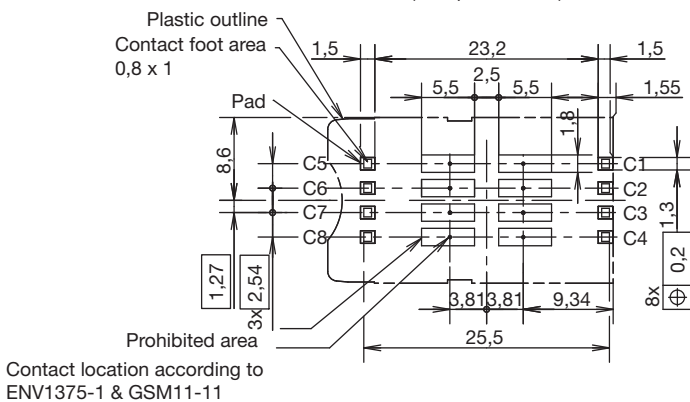

SIM/SAM



Dimensions are shown in mm
Specifications and dimensions subject to change

www.ck-components.com

CCM03 MK2 Series

CCM03-3012 LFT

SIM/SAM

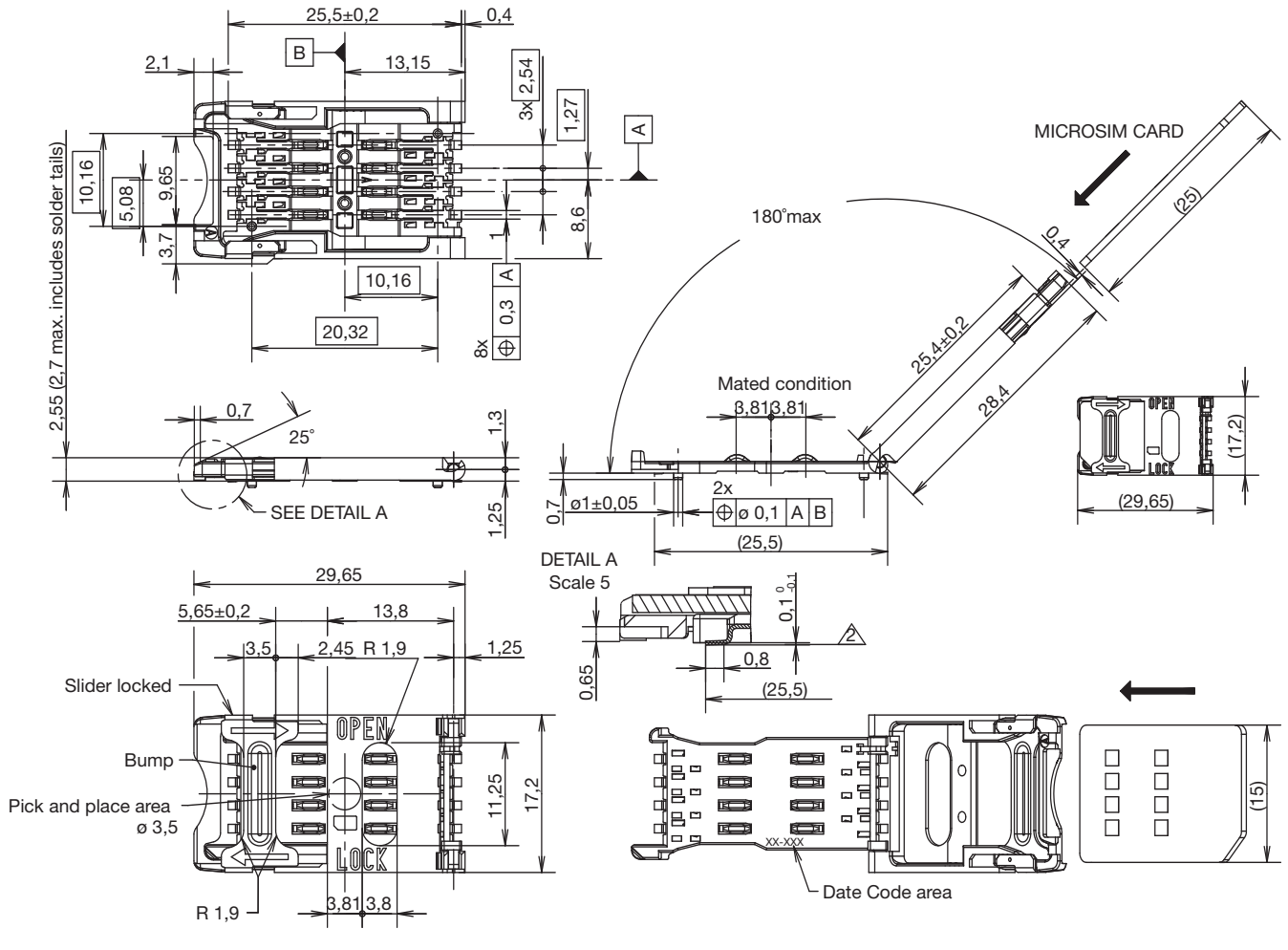

RECOMMENDED PC BOARD LAYOUT (Component side)

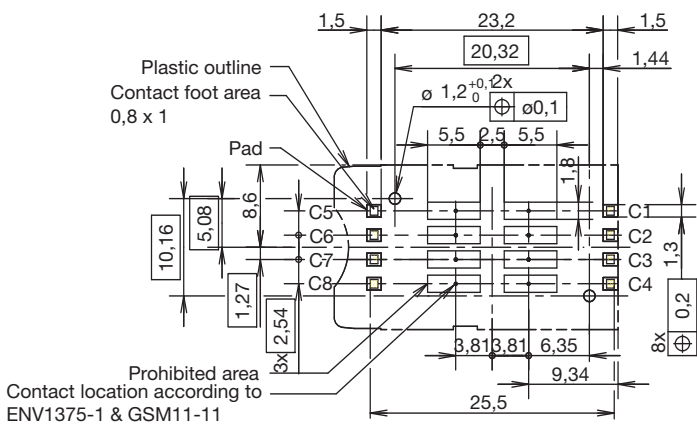

Dimensions are shown in mm
Specifications and dimensions subject to change



CCM03 MK2 Series

CCM03-3013 LFT

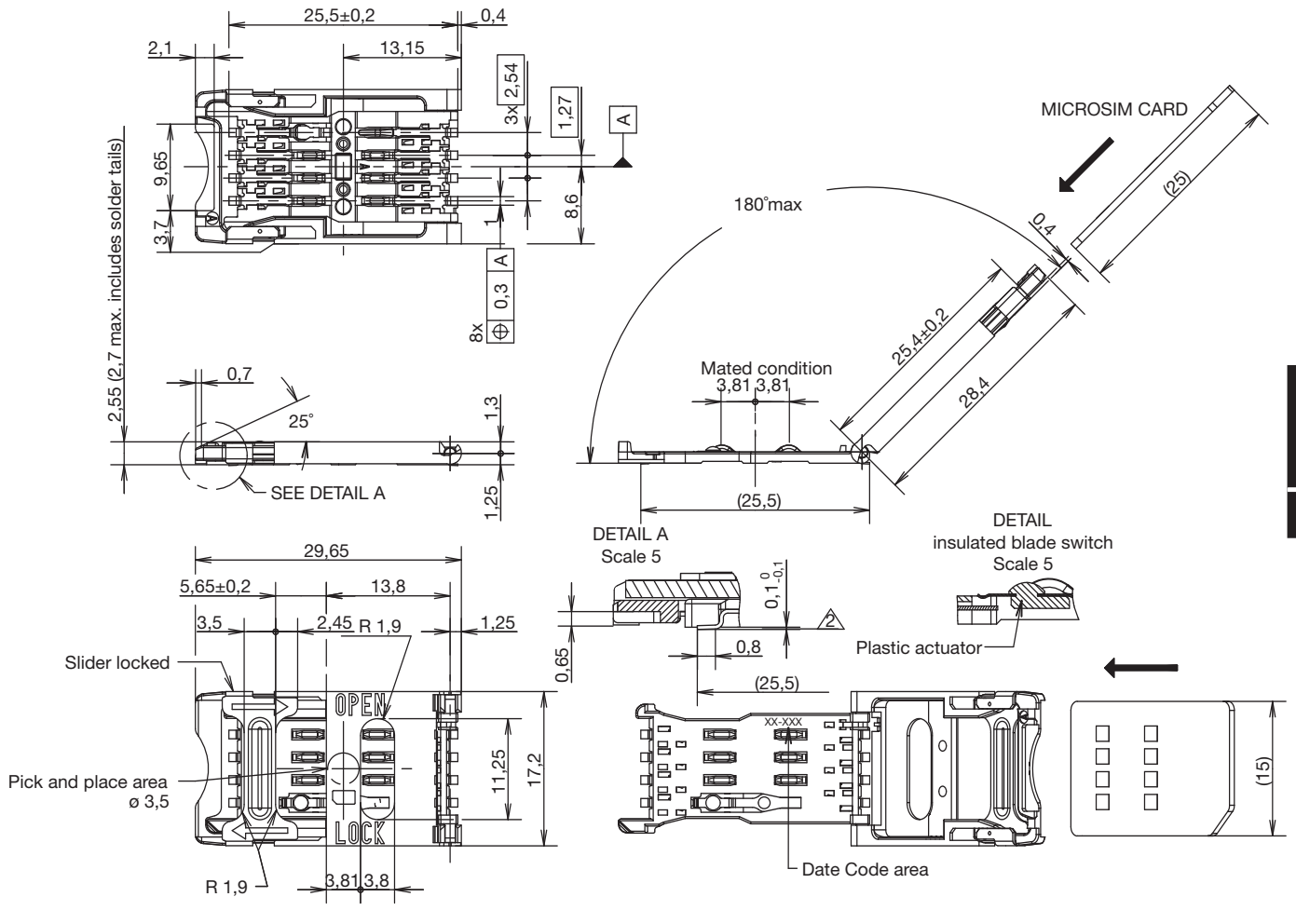

RECOMMENDED PC BOARD LAYOUT (Component side)

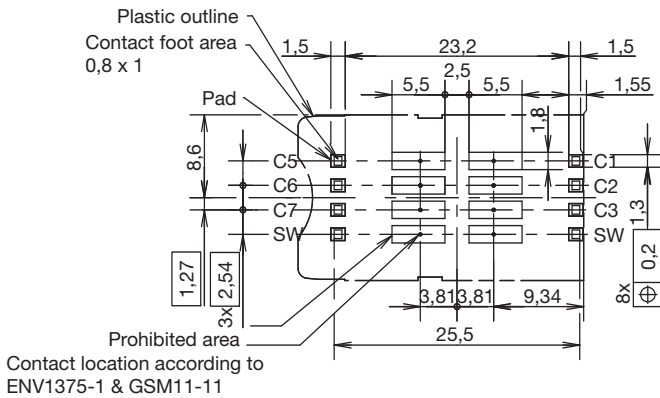

Dimensions are shown in mm
Specifications and dimensions subject to change

www.ck-components.com

CCM03 MK2 Series

CCM03-3512 LFT

SIM/SAM

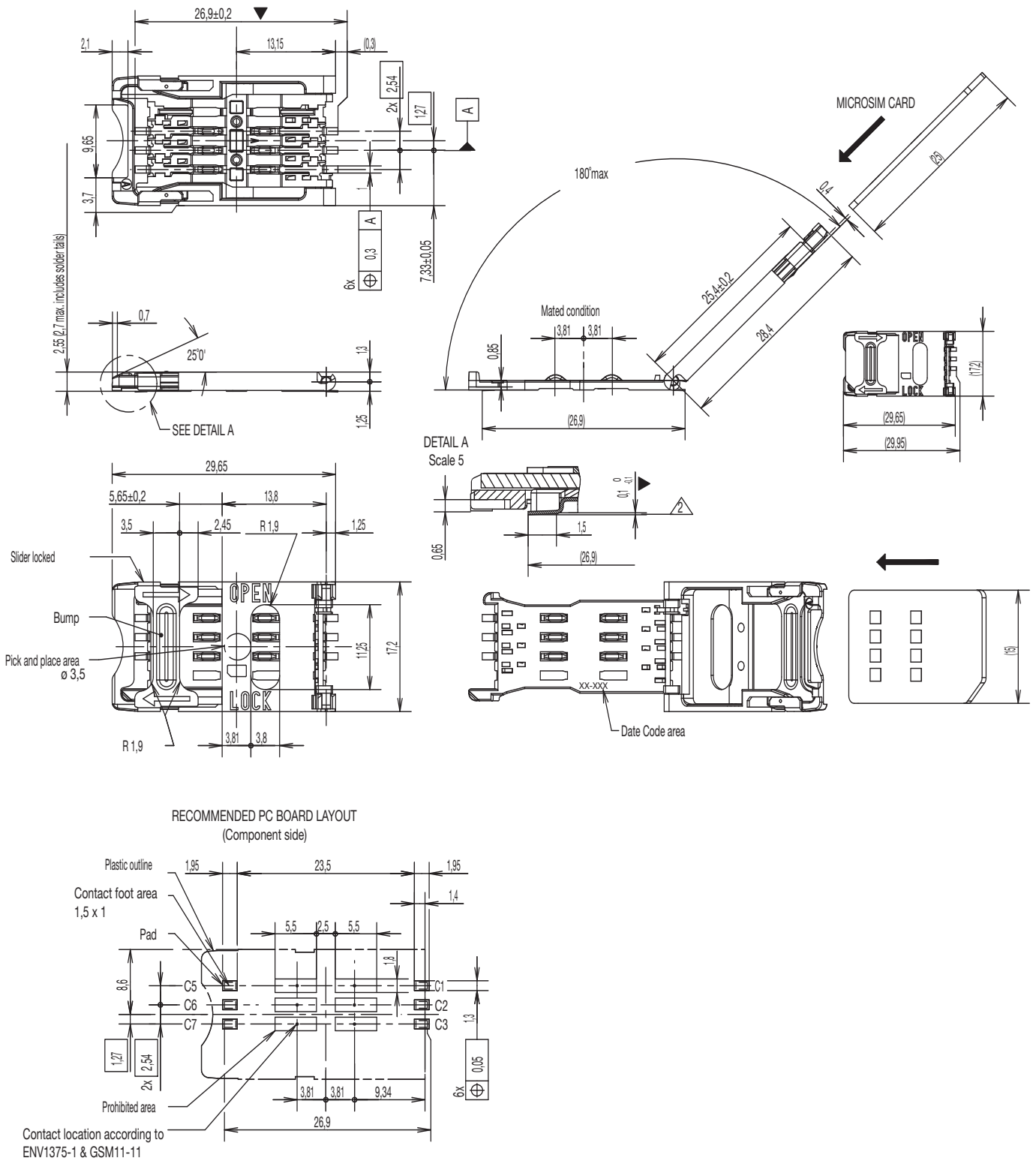

Dimensions are shown in mm
Specifications and dimensions subject to change

www.ck-components.com



CCM03 MK2 Series

CCM03-3504 LFT / CCM03-3505 LFT

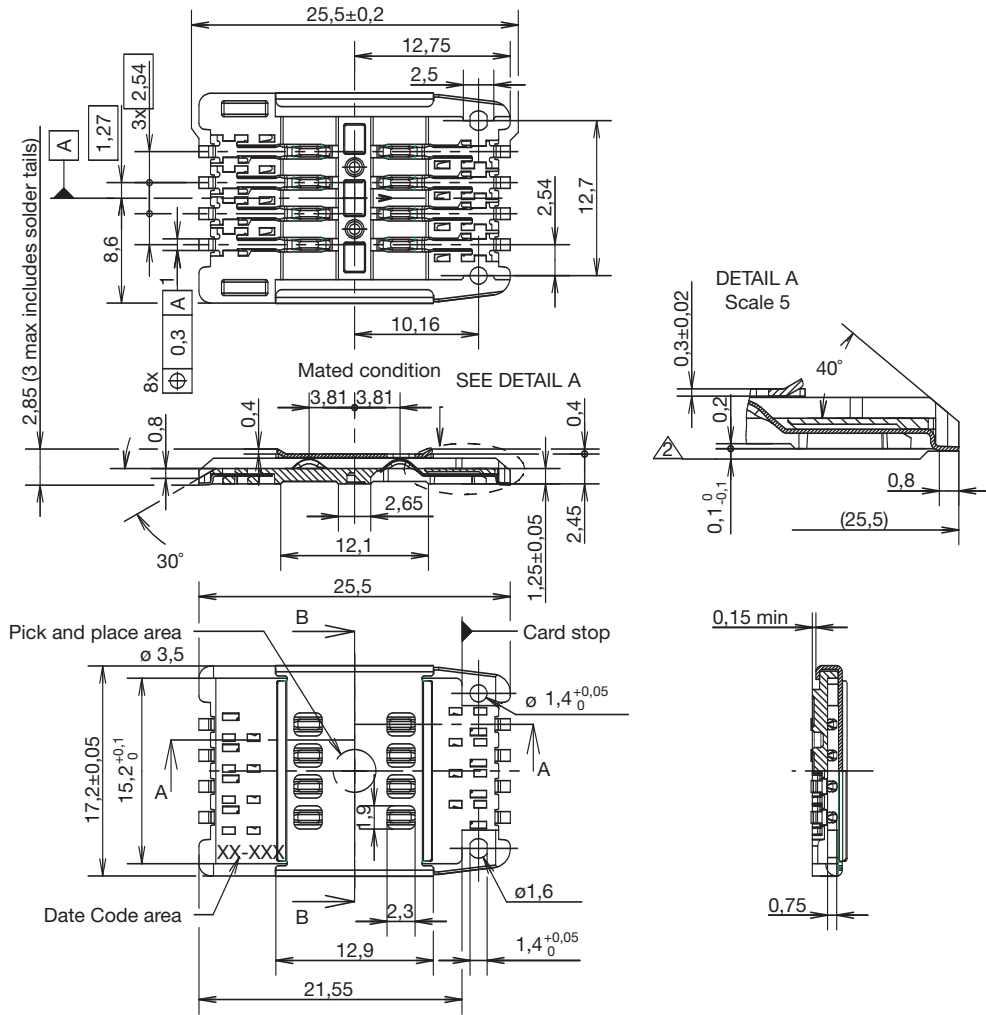

RECOMMENDED PC BOARD LAYOUT
(Component side)

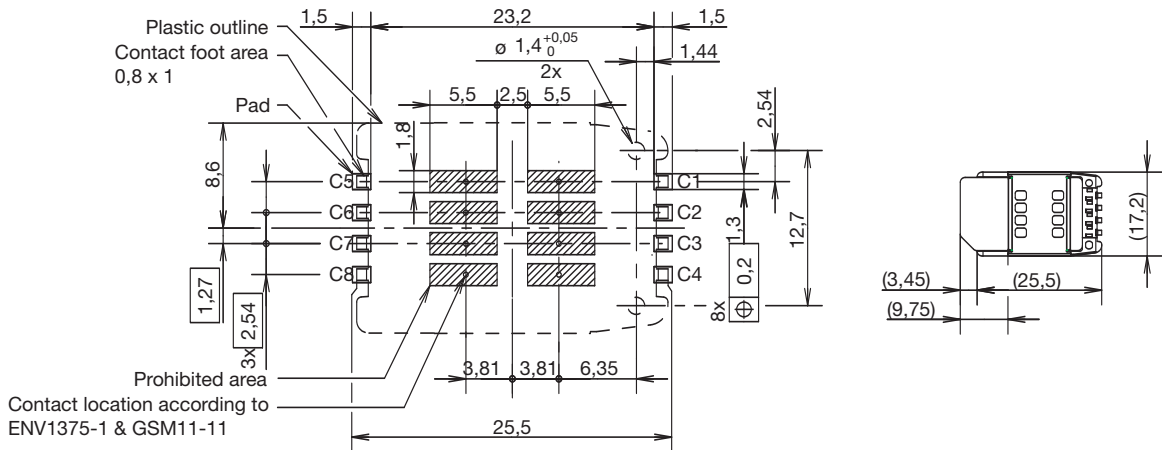

SIM/SAM



Dimensions are shown in mm
Specifications and dimensions subject to change

www.ck-components.com

CCM03 MK2 Series

CCM03-3754 LFT

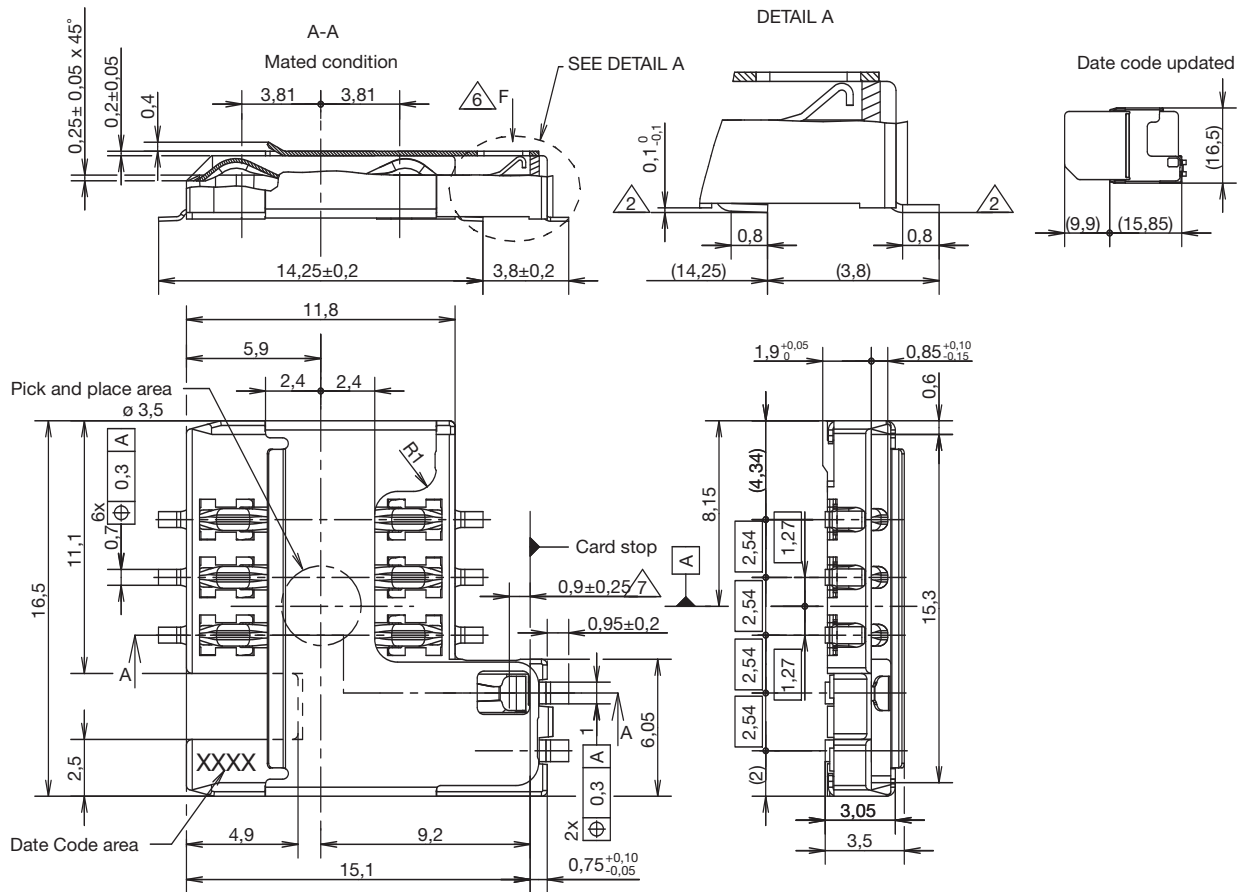

RECOMMENDED PC BOARD LAYOUT
(Component side)

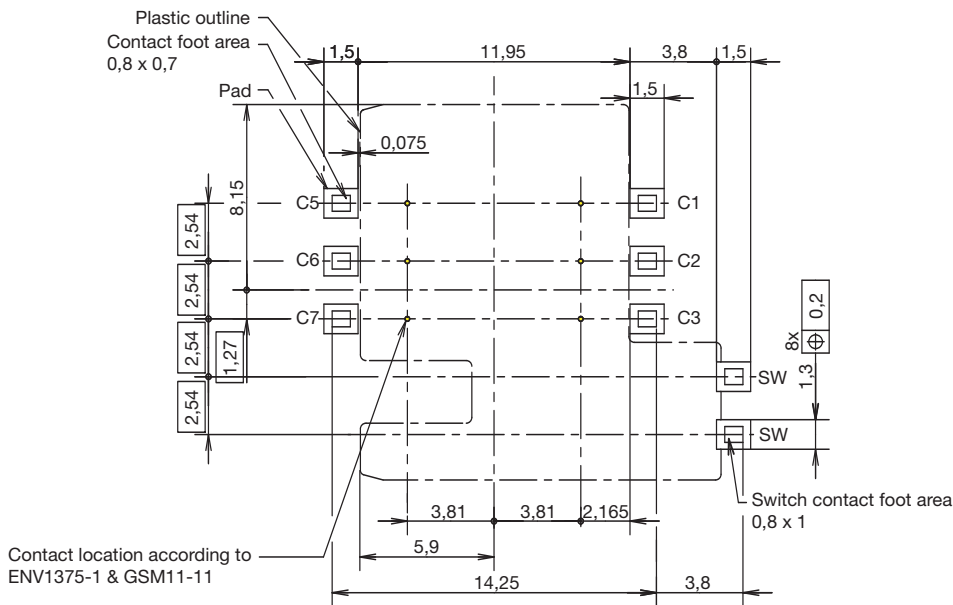

Dimensions are shown in mm
Specifications and dimensions subject to change

www.ck-components.com

SIM/SAM



CCM03 MK2 Series

CCM03-3760 LFT

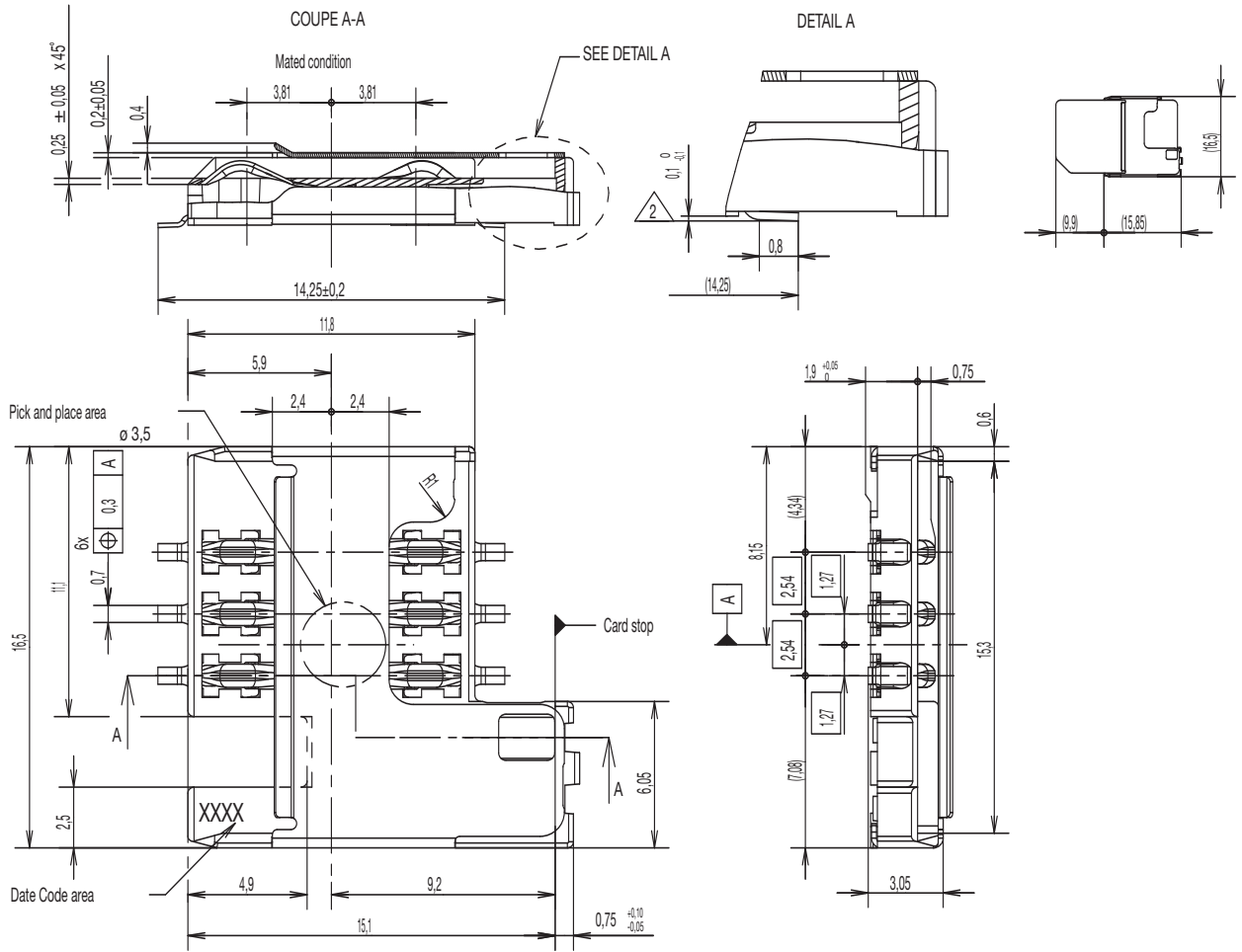

RECOMMENDED PC BOARD LAYOUT
 (Component side)

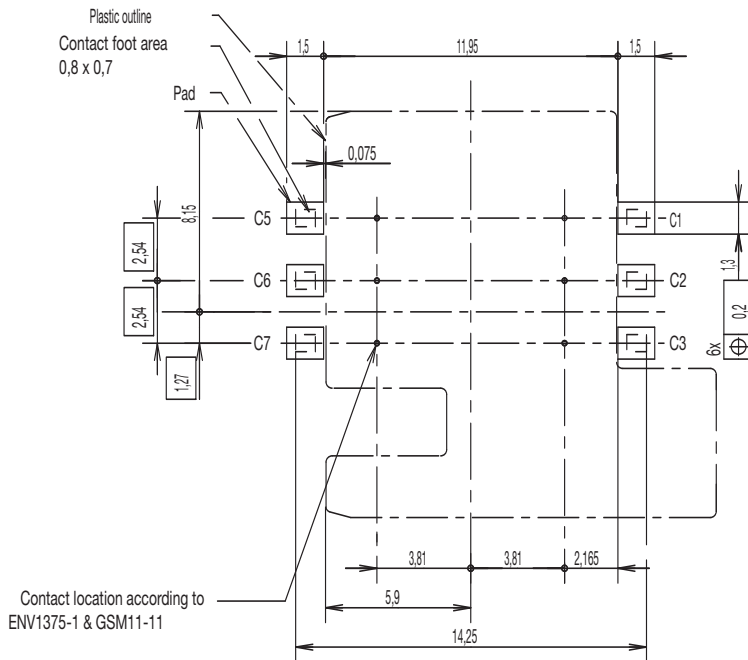

Dimensions are shown in mm
 Specifications and dimensions subject to change

www.ck-components.com

SIM/SAM

CCM03 MK2 Series

CCM03-3764 LFT

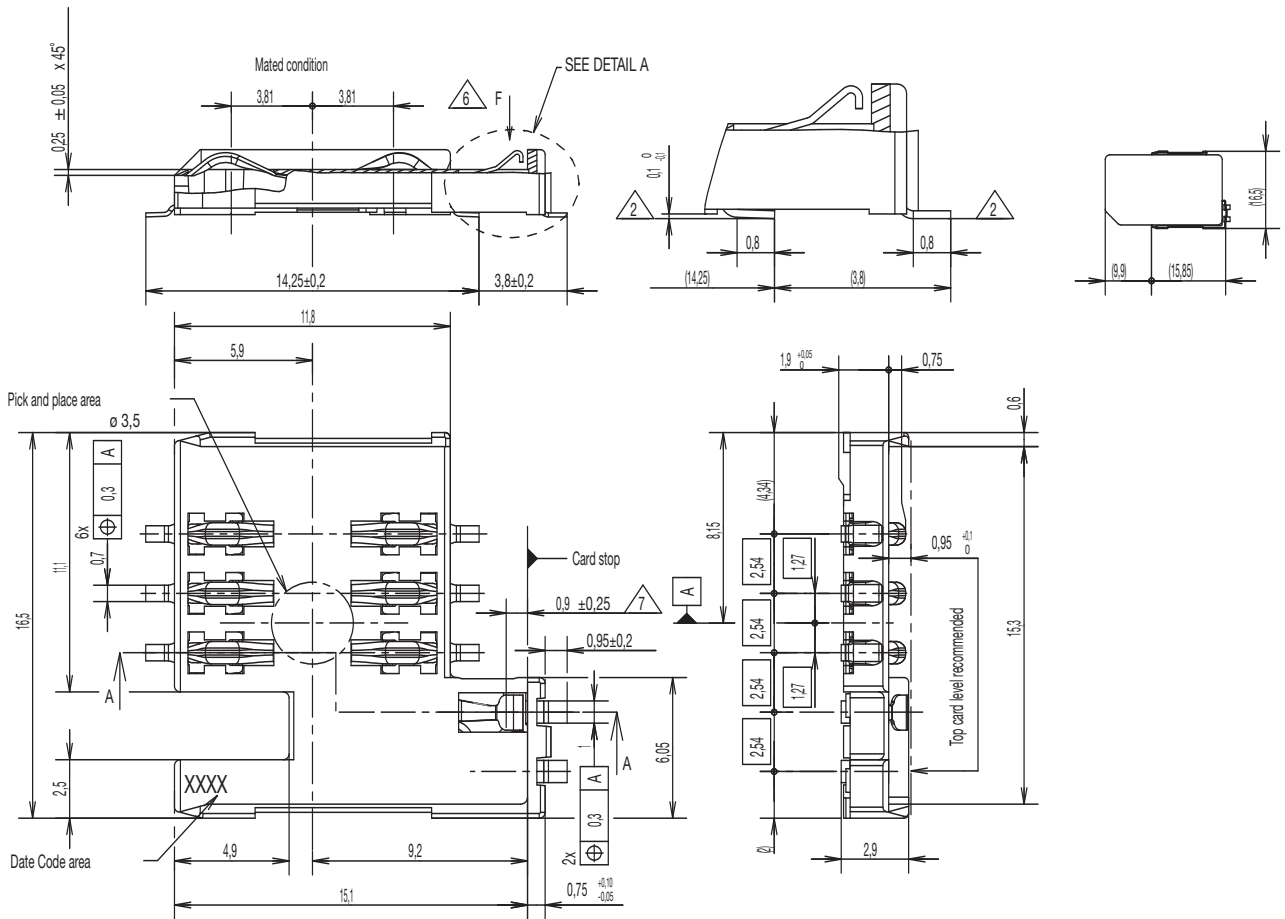

RECOMMENDED PC BOARD LAYOUT
(Component side)

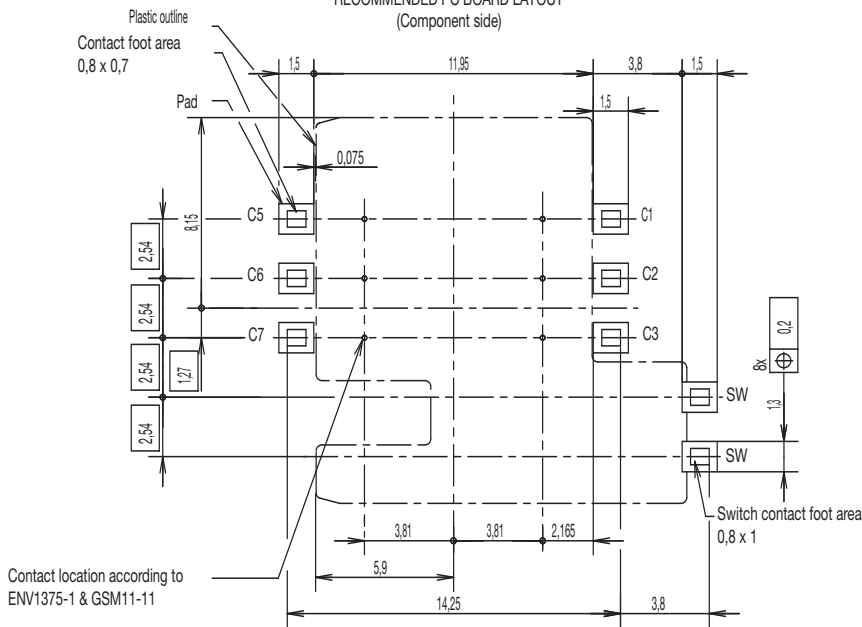

Contact location according to
ENV1375-1 & GSM11-11



First Angle
Projection

Dimensions are shown in mm
Specifications and dimensions subject to change

www.ck-components.com

SIM/SAM



CCM04 MK3 Series



Features

- SIM and SAM card acceptance
- Compatible with pick and place and lead free soldering

Typical Applications

- Mobile
- POS
- Identification
- GPS

Mechanical

| | |
|--------------------------|---|
| Number of contacts | 6 or 8 |
| Mechanical life | 30,000 cycles |
| Card insertion force | 10N max |
| Card extraction force | 1N min / 10N max |
| Contact force | 0,35N min to 0,65N |
| Vibration Frequency | 10 to 500 Hz. Acceleration 50m/s ² Duration 6 hours - amplitude 0,35mm |
| Shock | Peak value 500 m/s ² – Duration 11 ms 3 shocks in each direction of each axis |
| Max elect. discontinuity | 1µs |

Packaging

See table below

Soldering Process

Compatible with lead free SMT soldering process

Contact Electrical Data

| | |
|------------------------|---------------------|
| Insulation resistance | 1000 MΩ min |
| Contact resistance max | 100 mΩ max |
| Switching current | 10 µA min / 1 A max |
| Dielectric strength | 750 Vrms min |

Environmental Data

| | |
|-----------------------|------------------------------------|
| Operating temperature | -40°C to +85°C |
| Salt mist | IEC 512 test number 11f (96 hours) |
| Damp heat | IEC 512 test number 11c (10 days) |
| RoHS compliant | |

SIM/SAM

| Designation | # of Contacts | Contact Plating | PCB Version | Height (mm) | Dim. (mm) | Packaging |
|---------------|---------------|-----------------|-------------|-------------|--------------|--------------------|
| CCM04-5137LFS | 6 | gold | SMT IN | 1,9 | 8,15 X 10,45 | reels of 1,900 pcs |

CCM04 MK3 Series

CCM04-5137 LFS

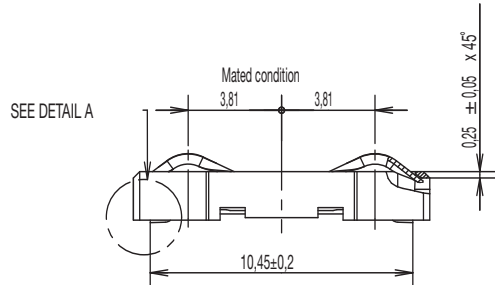
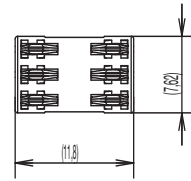
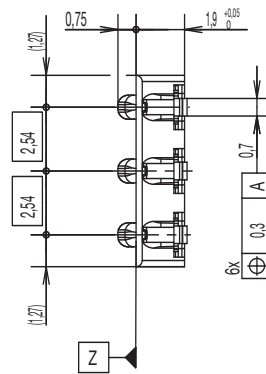
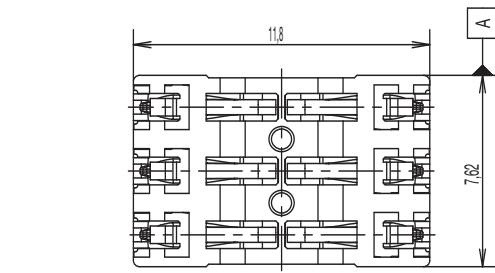

DETAIL A
Scale 10

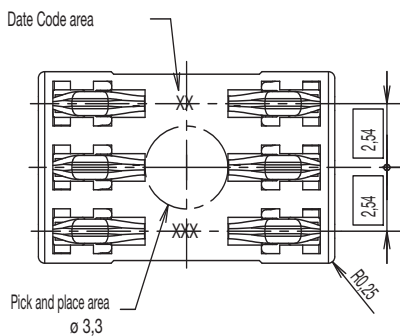
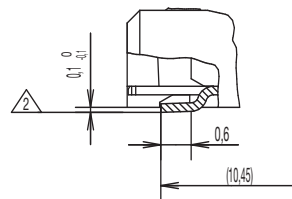

RECOMMENDED PC BOARD LAYOUT
(Component side)

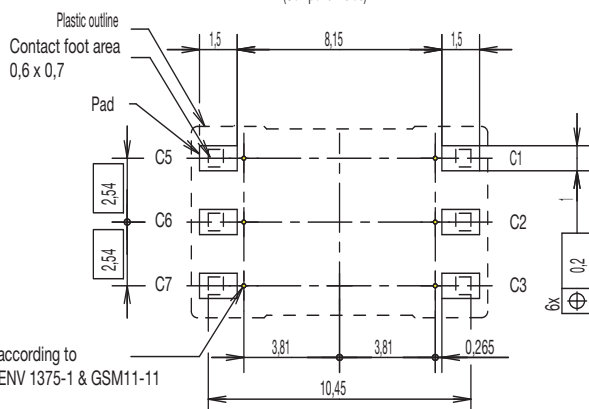

SIM/SAM



Dimensions are shown in mm
Specifications and dimensions subject to change

www.ck-components.com

X-ON Electronics

Largest Supplier of Electrical and Electronic Components

Click to view similar products for [Tactile Switches](#) category:

Click to view products by [C&K](#) manufacturer:

Other Similar products are found below :

[6407-250V-25273P](#) [ADTSA62NV](#) [B3F-3123](#) [1977177-8](#) [1977266-1](#) [ADTSA63NV](#) [ADTSM21NSVTR](#) [ADTSM25RVTR](#) [ADTSM32NVTR](#)
[ADTSMW64RV](#) [1977120-6](#) [FSMRA4JHA04](#) [GS4.70F300QP](#) [KSC241J SP DELTA LFS](#) [3FTL600RAS](#) [3FTL640RAS](#) [6407-250V-25343P](#)
[ADTSM31NVTR](#) [2-1977120-7](#) [TSJW-5.2-260-TR](#) [Y651050400P](#) [KMT011MNGJLHS](#) [70-201.0](#) [ADTSG648NV](#) [ADTSM62KSVTR](#)
[ADTSM648NV](#) [95C06E3RAT](#) [3ATH9Q](#) [FSMRA8JHA04](#) [HARS0073](#) [Y33R411N9FPLFT](#) [Y33R51139FPLFT](#) [Y31C01402FPLFS](#)
[PTS645SK50SMTR92](#) [ADTSM32NVB](#) [KMS233GPWTLFG](#) [Y78B64124FP](#) [Y31CJ244KFP LFS](#) [Y33A812C5FP LFT](#) [Y56B2D120FP LFS](#)
[Y31C5144KFP LFS](#) [PTS645 DVM83-BN125-2 LFS](#) [B3W 1000G](#) [KSC621G OL LFS](#) [B3F 1002C](#) [B3F 0047H](#) [B3W 1002C](#) [B3F 5001G](#)
[B3W 1100C](#) [1-1571563-4](#)