

ABG-H Series

Features

- Fe base metal material core provides large saturation current.
- Metallization on Ferrite Core results in excellent shock resistance and damage-free durability.
- Closed magnetic circuit design reduces leakage flux and Electro Magnetic Interference(EMI).
- Low DCR decreases power loss, small and slim take up less PCB real estate.
- Automatic production ensures high quality and consistency.
- RoHS compliance.

Applications

- LED Lighting & Smart phone.
- Blue -ray disc recorders, set top box.
- Next-generation mobile devices with multifunction such as adding color TV and digital movie cameras.
- Flat-screen TVs,blue-ray disc recorders set top box.
- Notebooks,desktop computers,servers,graphic cards.
- Portable gaming devices,personal navigation systems,personal multimedia devices.

Test Equipment and Conditions

- Inductance is measured with IM3536 LCR meter or equivalent.
- Operating temperature range -40°C to +125°C.(Including self - temperature rise).
- DC current(Irms)that will cause an approximate ΔT of 40°C.
- DC current(Isat)that will cause L0 to drop approximately 35%.
- For ABG02 & ABG25 size inductors, absolute maximum voltage: DC 25V;
For ABG03 & ABG04 size inductors, absolute maximum voltage: DC 40V;

External dimensions (Unit:m/m)

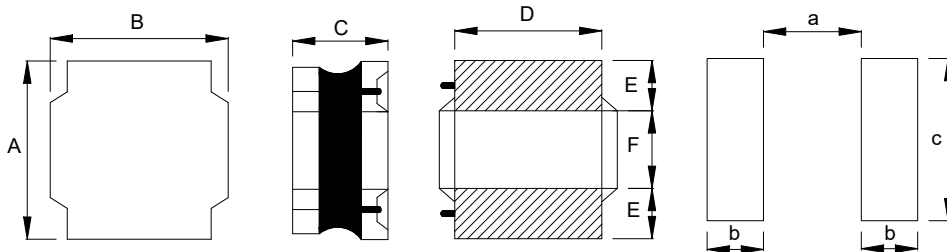

Type	A	B	C	D Typ.	E Typ.	F Typ.	a Typ.	b Typ.	c Typ.	Q'TY/Reel
ABG02H10	2.1±0.3	1.7±0.3	1.05Max	1.7	0.7	0.7	0.4	1.0	2.0	2000
ABG25H10	2.5±0.3	2.2±0.3	1.05Max	1.65	0.8	0.9	0.6	1.1	1.95	2000
ABG25H12	2.5±0.3	2.2±0.3	1.25Max	1.65	0.8	0.9	0.6	1.1	1.95	2000

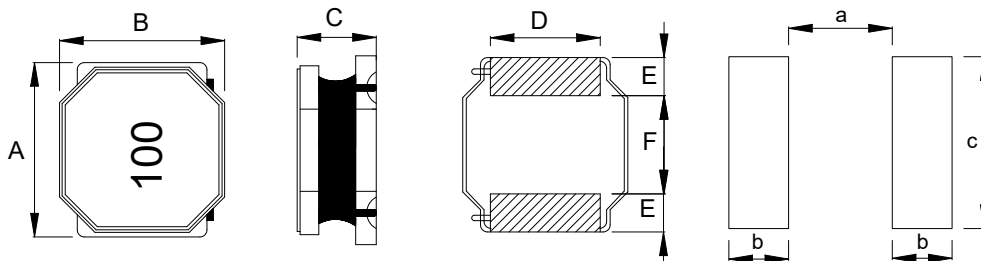

Type	A	B	C	D Typ.	E Typ.	F Typ.	a Typ.	b Typ.	c Typ.	Q'TY/Reel
ABG03H12	3.0±0.2	3.0±0.2	1.35Max	2.55	0.9	1.2	1.1	1.0	3.4	2000
ABG04H12	4.0±0.2	4.0±0.2	1.35Max	3.5	1.3	1.4	1.1	1.6	3.8	4500
ABG04H20	4.0±0.2	4.0±0.2	2.00Max	3.5	1.0	2.0	1.3	1.5	3.8	3000

Part Number Code

ABG 02 H 10 N R24
 A B C D E F

A: Series Name Power Inductors
 B: Dimensions(mm) 02: 2.1 x 1.7
 C: Materials H Type
 D: Thickness(mm) 10: 1.05 Max
 E: Tolerance N: ±30% M: ±20%
 F: Inductance R24=0.24uH

ABG-H Series

Part Number	Inductance(μH) @1MHz/1V	DC Resistance (Ω) Max.	Self-resonant Frequency (MHz) Min.	Heat Rating Current Irms (A) Max.	Saturation Current Isat (A) Max.
ABG02H10NR24	0.24	0.039	145	3.02	4.54
ABG02H10NR39	0.39	0.053	104	4.10	4.10
ABG02H10NR47	0.47	0.055	102	2.72	4.03
ABG02H10NR68	0.68	0.064	77	2.53	3.53
ABG02H10M1R0	1.0	0.089	70	2.07	3.38
ABG02H10M1R5	1.5	0.128	45	1.72	1.97
ABG02H10M2R2	2.2	0.192	39	1.46	1.92
ABG02H10M4R7	4.7	0.423	25	0.91	1.21
ABG02H10M5R6	5.6	0.500	17	0.90	1.00
ABG02H10M6R8	6.8	0.540	16	0.53	0.73
ABG02H10M100	10.0	0.824	15	0.65	0.81
ABG25H10NR33	0.33	0.038	117	3.52	4.83
ABG25H10NR47	0.47	0.044	80	3.23	4.43
ABG02H10NR56	0.56	0.055	66	2.50	3.80
ABG25H10NR68	0.68	0.058	65	2.77	3.23
ABG25H10M1R0	1.0	0.075	46	2.51	3.12
ABG25H10M1R5	1.5	0.105	40	2.02	2.62
ABG25H10M2R2	2.2	0.153	26	1.51	1.91
ABG25H10M3R3	3.3	0.233	24	1.20	1.60
ABG25H10M4R7	4.7	0.300	19	1.11	1.31
ABG25H10M100	10.0	0.530	12	0.85	0.93
ABG25H12NR24	0.24	0.029	117	4.10	6.55
ABG25H12NR33	0.33	0.036	104	3.40	5.41
ABG25H12NR47	0.47	0.040	89	3.00	5.00
ABG25H12NR68	0.68	0.050	67	3.18	3.73
ABG25H12M1R0	1.0	0.060	52	3.03	3.70
ABG25H12M1R5	1.5	0.090	35	2.40	2.92
ABG25H12M2R2	2.2	0.117	32	1.96	2.60
ABG25H12M3R3	3.3	0.190	25	1.82	1.77
ABG25H12M4R7	4.7	0.256	23	1.26	1.66

ABG-H Series

Part Number	Inductance(μ H) @1MHz/1V	DC Resistance (Ω) Max.	Self-resonant Frequency (MHz) Min.	Heat Rating Current I _{rms} (A) Max.	Saturation Current I _{sat} (A) Max.
ABG25H12M6R8	6.8	0.364	16	0.97	1.20
ABG25H12M100	10.0	0.480	12	0.85	1.15
ABG25H12M220	22.0	1.080	10	0.70	0.70
ABG03H12NR33	0.33	0.027	107	4.10	7.20
ABG03H12NR47	0.47	0.033	86	4.00	6.10
ABG03H12NR68	0.68	0.040	63	3.80	5.80
ABG03H12M1R0	1.0	0.054	51	2.80	4.00
ABG03H12M1R5	1.5	0.074	37	2.00	3.20
ABG03H12M2R2	2.2	0.108	28	1.90	2.20
ABG03H12M3R3	3.3	0.150	25	1.60	1.70
ABG03H12M4R7	4.7	0.230	20	1.40	1.50
ABG03H12M6R8	6.8	0.340	16	1.10	1.40
ABG03H12M100	10.0	0.460	12	0.90	1.00
ABG04H12NR33	0.33	0.032	113	4.50	8.00
ABG04H12NR47	0.47	0.040	96	4.20	7.50
ABG04H12NR68	0.68	0.040	70	4.10	5.00
ABG04H12M1R0	1.0	0.058	55	3.50	4.50
ABG04H12M1R2	1.2	0.064	48	3.20	4.00
ABG04H12M1R5	1.5	0.070	38	2.60	3.90
ABG04H12M2R2	2.2	0.079	28	2.50	2.80
ABG04H12M3R3	3.3	0.125	23	1.90	2.00
ABG04H12M4R7	4.7	0.166	19	1.70	1.80
ABG04H12M6R8	6.8	0.226	17	1.50	1.60
ABG04H12M100	10.0	0.335	12	1.30	1.50
ABG04H12M220	22.0	0.679	7	0.85	0.90
ABG04H20NR47	0.47	0.022	72	7.00	10.0
ABG04H20NR68	0.68	0.035	57	5.00	8.70
ABG04H20M1R0	1.0	0.026	37	5.10	8.50
ABG04H20M1R5	1.5	0.036	30	4.50	7.20
ABG04H20M2R2	2.2	0.048	25	4.20	6.10
ABG04H20M3R3	3.3	0.072	19	3.50	4.20
ABG04H20M4R7	4.7	0.108	17	2.50	4.00
ABG04H20M6R8	6.8	0.156	13	2.10	3.00
ABG04H20M100	10.0	0.216	11	1.70	2.80

Reliability Test

Item	Specifications	Test conditions
High temperature storage test	No visible mechanical damage. Inductance change: Within $\pm 10\%$.	<p>Temperature: $125 \pm 2^\circ\text{C}$. Duration: 1000hrs. Measured at room temperature after placing for 24 ± 4 hrs.</p> <p>The graph shows a temperature profile over time. The y-axis is labeled 'Temp' with markers at 125°C, 25°C, and 0°C. The x-axis is labeled 'Test Time' with markers at '1000H' and '24H'. The temperature starts at 125°C, remains constant for 1000 hours, then drops to 25°C for 24 hours, and finally drops to 0°C.</p>
Temperature cycling test	No visible mechanical damage. Inductance change: Within $\pm 10\%$.	<p>Condition for 1 cycle. Step1: $-40 \pm 2^\circ\text{C}$ 30min Min. Step2: $125 \pm 2^\circ\text{C}$, transition time 1min Max. Step3: $125 \pm 2^\circ\text{C}$ 30min Min. Step4: Low temp, transition time 1min Max. Number of cycles: 1000. Measured at room temperature after placing for 24 ± 4 hrs.</p> <p>The graph shows a temperature profile over time. The y-axis is labeled 'Temp' with markers at 125°C, 25°C, 0°C, and -40°C. The x-axis is labeled 'Time'. The temperature starts at -40°C, rises to 125°C with a transition time of less than 1 minute, remains constant at 125°C for 30 minutes, then drops to a low temperature (likely 25°C) with a transition time of less than 1 minute, and remains constant at that low temperature for 30 minutes.</p>
Biased humidity test	No visible mechanical damage. Inductance change: Within $\pm 10\%$.	<p>Humidity : $85\% \pm 3$ RH. Temperature: $85^\circ\text{C} \pm 2^\circ\text{C}$. Duration : 1000hrs. Measured at room temperature after placing for 24 ± 4 hrs.</p>
Operational life test	No visible mechanical damage. Inductance change: Within $\pm 10\%$.	<p>Temperature: $105 \pm 2^\circ\text{C}$. Duration : 1000hrs. Measured at room temperature after placing for 24 ± 4 hrs.</p>
Resistance to solvent test	No visible mechanical damage. Inductance change: Within $\pm 10\%$.	Add aqueous wash chemical - OKEM clean or equivalent.

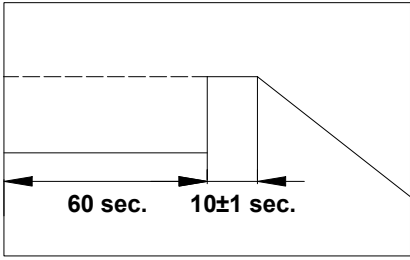
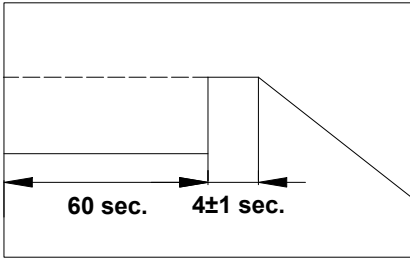
Item	Specifications	Test conditions
Vibration test	No visible mechanical damage. Inductance change: Within $\pm 10\%$.	Oscillation Frequency: 10~2K~10Hz for 20 minute. Total Amplitude:1.52mm $\pm 10\%$. Testing Time:12 hours(20 minutes, 12 cycles each of 3 orientations).
Resistance to soldering heat test	No visible mechanical damage. Inductance change: Within $\pm 10\%$.	Temperature ($^{\circ}\text{C}$): 260 ± 5 (solder temp). Time (s): 10 ± 1 . ramp/immersion and emersion rate: 25mm/s ± 6 mm/s. Number of heat cycles:1. 
Solderability test	More than 95% of the terminal electrode should be covered with solder.	Steam Aging: 8 hours ± 15 min. Preheat: 150 $^{\circ}\text{C}$,60sec. Solder: Sn99.5%-Cu0. 5%. Temperature: 245 $\pm 5^{\circ}\text{C}$. Flux for lead free: Rosin. 9.5%. Dip time: 4 ± 1 sec. Depth: completely cover the termination. 
Terminal strength (SMD) test	No visible mechanical damage.	With the component mounted on a PCB with the device to be tested, apply a 17.7 N (1.8 Kg) force to the side of a device being tested. This force shall be applied for 60 +1 seconds. Also the force shall be applied radually as not to apply a shock to the component being tested.

Packaging

Taping Dimensions (Unit: mm)

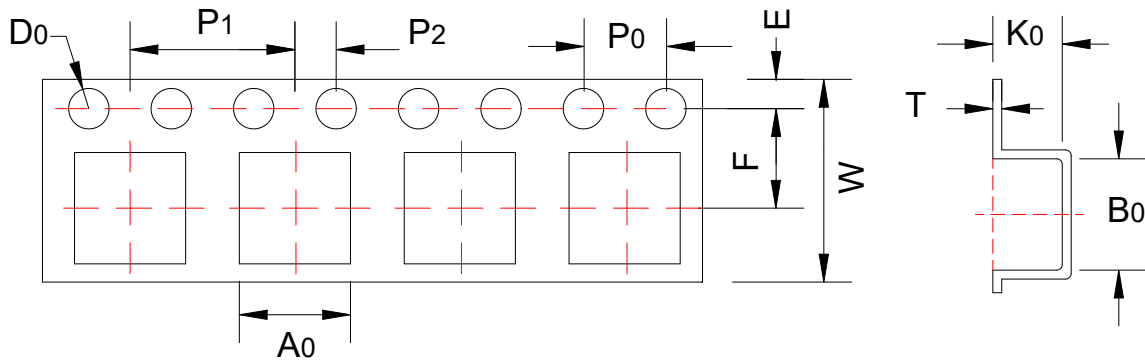

TYPE	A0	B0	W	E	F	P0	P1	P2	D0	T	K0
ABG02H10	1.9±0.1	2.35±0.1	8.0±0.3	1.75±0.1	3.5±0.1	4.0±0.1	4.0±0.1	2.0±0.1	1.5±0.1	0.2±0.05	1.1±0.1
ABG25H10	2.4±0.1	2.8±0.1	8.0±0.3	1.75±0.1	3.5±0.1	4.0±0.1	4.0±0.1	2.0±0.1	1.5±0.1	0.2±0.05	1.35±0.1
ABG25H12	2.4±0.1	2.8±0.1	8.0±0.3	1.75±0.1	3.5±0.1	4.0±0.1	4.0±0.1	2.0±0.1	1.5±0.1	0.2±0.05	1.35±0.1
ABG03H12	3.3±0.1	3.3±0.1	8.0±0.3	1.75±0.1	3.5±0.1	4.0±0.1	4.0±0.1	2.0±0.1	1.5±0.1	0.25±0.05	1.3±0.1
ABG04H12	4.25±0.1	4.25±0.1	12.0±0.3	1.75±0.1	5.5±0.1	4.0±0.1	8.0±0.1	2.0±0.1	1.5±0.1	0.3±0.05	1.4±0.1
ABG04H20	4.25±0.1	4.25±0.1	12.0±0.3	1.75±0.1	5.5±0.1	4.0±0.1	8.0±0.1	2.0±0.1	1.5±0.1	0.3±0.05	2.5±0.1

Reel Dimensions (Unit: mm)

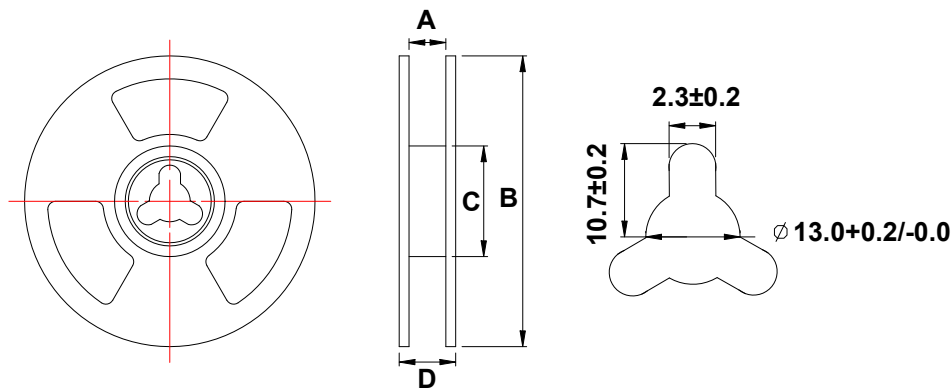

TYPE	A	B	C	D
ABG02H10	8.5±2.0	178.0±2.0	58.0±2.0	10.5±2.0
ABG25H10	8.5±2.0	178.0±2.0	58.0±2.0	10.5±2.0
ABG25H12	8.5±2.0	178.0±2.0	58.0±2.0	10.5±2.0
ABG03H12	8.5±2.0	178.0±2.0	58.0±2.0	10.5±2.0
ABG04H12	12.5±2.0	330.0±2.0	100.0±2.0	16.5±2.0
ABG04H20	12.5±2.0	330.0±2.0	100.0±2.0	16.5±2.0

Recommended Soldering Technologies

Re-flowing Profile:

- △ Preheat condition: 150~200°C/60~120sec.
- △ Allowed time above 217°C: 60~90sec.
- △ Max temp: 260°C
- △ Max time at max temp: 5sec.
- △ Solder paste: Sn/3.0Ag/0.5Cu
- △ Allowed Reflow time: 2x max

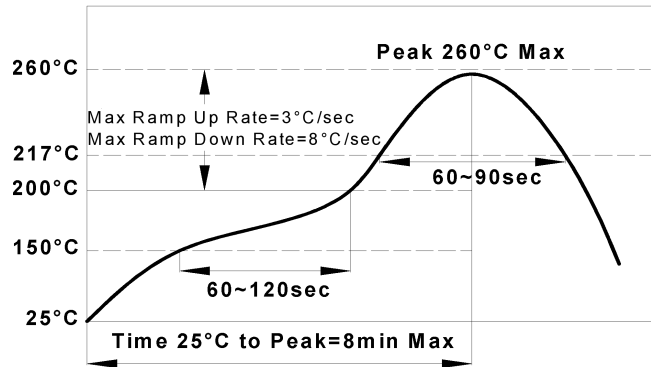

Iron Soldering Profile:

- △ Iron soldering power: Max.30W
- △ Pre-heating: 150°C/60sec.
- △ Soldering Tip temperature: 350°CMax.
- △ Soldering time: 3sec Max.
- △ Solder paste: Sn/3.0Ag/0.5Cu
- △ Max.1 times for iron soldering

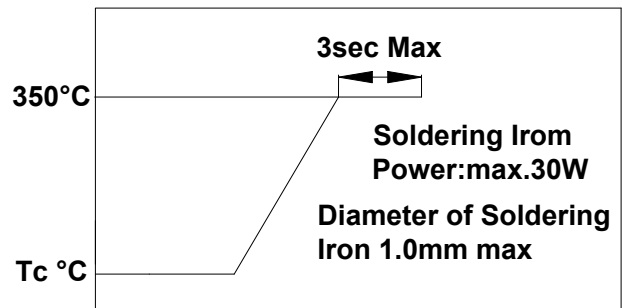

[Note: Take care not to apply the tip of the soldering iron to the]

X-ON Electronics

Largest Supplier of Electrical and Electronic Components

Click to view similar products for [Fixed Inductors](#) category:

Click to view products by [COILANK](#) manufacturer:

Other Similar products are found below :

[CR32NP-100KC](#) [70F224AI](#) [MHQ1005P10NJ](#) [MHQ1005P1N0S](#) [MHQ1005P2N4S](#) [MHQ1005P3N6S](#) [MHQ1005P5N1S](#) [MHQ1005P8N2J](#)
[PE-53601NL](#) [PE-53602NL](#) [PG0936.113NLT](#) [9220-20](#) [9310-16](#) [PM06-2N7](#) [PM06-39NJ](#) [A01TK](#) [1206CS-471XJ](#) [HC2-R47-R](#) [HC8-1R2-R](#)
[HCF1305-3R3-R](#) [1206CS-151XG](#) [RCH664NP-4R7M](#) [RCP1317NP-391L](#) [DH2280-4R7M](#) [DS1608C-106](#) [B10TJ](#) [B82498B3101J000](#) [ELJ-](#)
[RE27NJF2](#) [1812CS-153XJ](#) [1812CS-183XJ](#) [1812CS-223XJ](#) [1812LS-104XJ](#) [1812LS-105XJ](#) [1812LS-124XJ](#) [1812LS-154XJ](#) [1812LS-223XJ](#)
[1812LS-224XJ](#) [1812LS-563XJ](#) [1812LS-683XJ](#) [1812LS-824XJ](#) [NIN-FB101JTR110F](#) [NIN-FB471JTR62F](#) [NIN-FC1R5JTR220F](#) [NIN-](#)
[HCR15JTRF](#) [NIN-HCR33JTRF](#) [NIN-HDR22JTRF](#) [NIN-HDR82JTRF](#) [NIN-HK2N7STRF](#) [NIN-PA150KTR370F](#) [NIN-PB100KTR550F](#)