

SMT Common Mode Chokes for power line applications

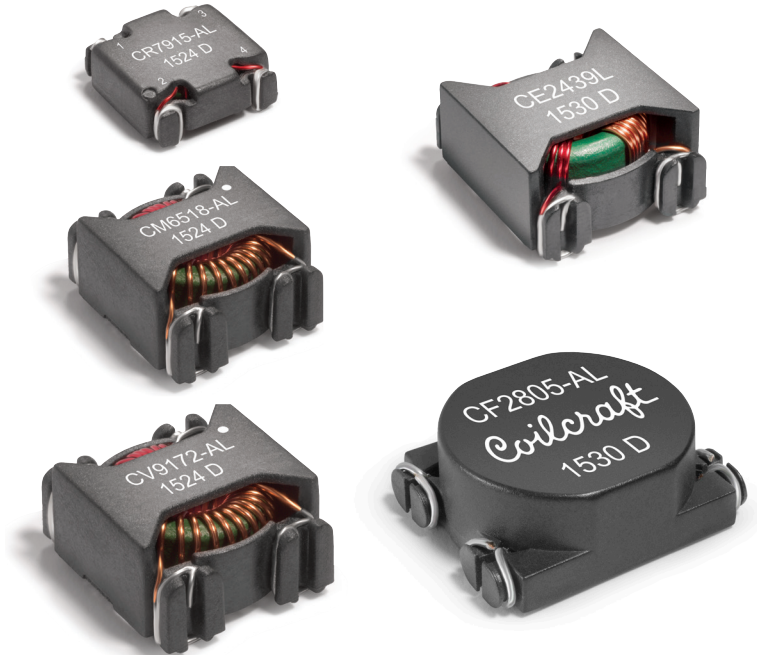

- Solutions for use in a wide array of power line circuits
- Ideal for use in consumer electronics and industrial applications
- Suppression of high frequency common mode noise up to 100 MHz
- Excellent current ratings – up to 10 A
- Isolation (hipot) up to 1500 Vrms
- Surface mount toroids
- Upon request, additional values may be available for particular applications



Part number	Common mode peak impedance (kOhms)	Inductance (mH)		Irms (A)	DCR max (mOhms)	Isolation (Vrms)	Length max (mm)	Width max (mm)	Height max (mm)	Page
		nom	min							
CE1755-AL	3.32 @ 5.1 MHz	0.88	0.57	1.2	130	1000	13.00	13.00	5.46	2
CR7915-AL	3.10 @ 4.9 MHz	1.12	0.73	2.6	49.5	1500	13.00	13.00	5.60	3
CF3094-AL	7.93 @ 2.5 MHz	1.17	0.76	1.1	200	1000	13.00	13.00	5.46	4
CM6518-AL	4.17 @ 1.9 MHz	1.40	0.91	2.5	60.0	1500	16.38	14.22	8.90	5
CJ5094-CL	28.28 @ 0.26 MHz	10.0	6.5	1.2	180	1000	16.38	14.22	8.90	6
CV9172-AL	70.01 @ 0.21 MHz	22.0	14.3	0.57	850	1000	16.38	14.22	8.90	7
CF2638L	2.59 @ 4.3 MHz	0.22	0.14	2.9	60.0	1000	19.56	17.02	9.91	8
CD1479-AL	4.19 @ 3.0 MHz	0.59	0.38	4.2	20.0	1000	19.56	17.02	9.91	9
CH4659-AL	4.56 @ 2.5 MHz	0.77	0.50	4.7	40.0	1000	19.56	17.02	9.91	10
CD1480-BL	4.53 @ 2.2 MHz	1.32	0.85	3.5	60.0	1000	19.56	17.02	9.91	11
CE2439L	9.42 @ 1.1 MHz	1.47	0.96	2.5	80.0	1000	19.56	17.02	9.91	12
CG3333-AL	2.27 @ 2.9 MHz	0.90	0.59	3.7	50.0	1000	19.56	17.02	9.90	13
CG3528-AL	6.23 @ 0.72 MHz	3.00	1.95	3.1	42.0	1000	19.56	17.02	9.91	14
CE1759-AL	4.82 @ 0.99 MHz	0.81	0.52	6.0	14.0	1000	31.0	26.0	13.0	15
CG3885-AL	3.11 @ 1.8 MHz	0.47	0.30	10.0	8.0	1000	31.0	26.0	12.7	16
CF2805-AL	3.64 @ 1.9 MHz	0.63	0.40	6.8	14.0	1000	31.0	26.0	12.7	17



www.coilcraft.com

US +1-847-639-6400 sales@coilcraft.com
UK +44-1236-730595 sales@coilcraft-europe.com
Taiwan +886-2-2264 3646 sales@coilcraft.com.tw
China +86-21-6218 8074 sales@coilcraft.com.cn
Singapore + 65-6484 8412 sales@coilcraft.com.sg

Document 1194P-1 Revised 09/09/21

© Coilcraft Inc. 2021

This product may not be used in medical or high risk applications without prior Coilcraft approval. Specification subject to change without notice. Please check web site for latest information.



Common Mode Choke – CE1755-AL

Part number ¹	Common mode impedance max (kOhms)	Inductance (mH) ²		I _{rms} ³ (A)	DCR max ⁴ (mOhms)	Isolation ⁵ (Vrms)
		nom	min			
CE1755-AL_	3.32 @ 5.1 MHz	0.88	0.57	1.2	130	1000

1. When ordering, please specify **packaging** code:

CE1755-ALD

Packaging: **D** = 13" machine-ready reel. EIA-481 embossed plastic tape (600 parts per full reel). Quantities less than full reel available: in tape (not machine ready) or with leader and trailer (\$25 charge).

B = Less than full reel. In an effort to simplify our part numbering system, Coilcraft is eliminating the need for multiple packaging codes. When ordering, simply change the last letter of your part number from B to D.

- Inductance shown for each winding, measured at 100 kHz, 0.1 Vrms, 0 Adc on an Agilent/HP 4263B LCR meter or equivalent.
- Current per winding that causes a 40°C rise from 25°C ambient. This information is for reference only and does not represent absolute maximum ratings.
- DCR is specified per winding.
- Isolation (hipot) measured for two seconds.
- Electrical specifications at 25°C.

Refer to Doc 362 "Soldering Surface Mount Components" before soldering.

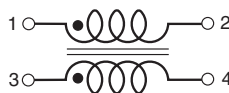
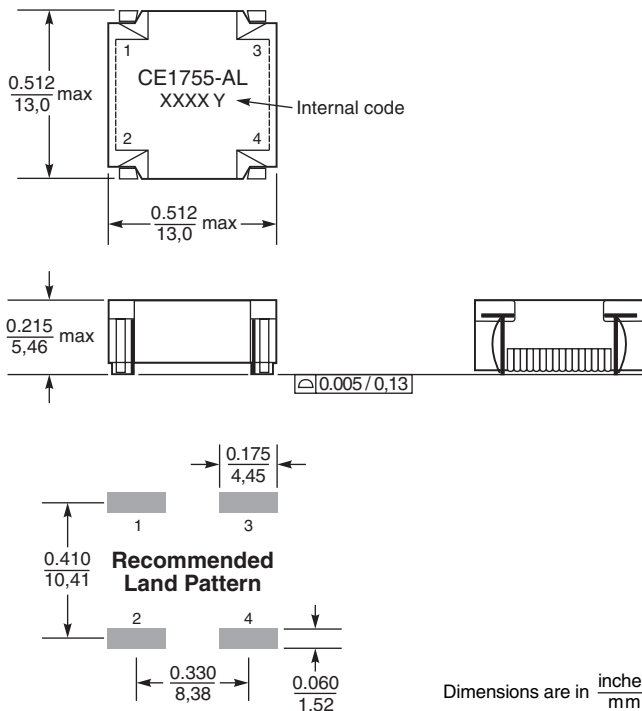

Typical Attenuation

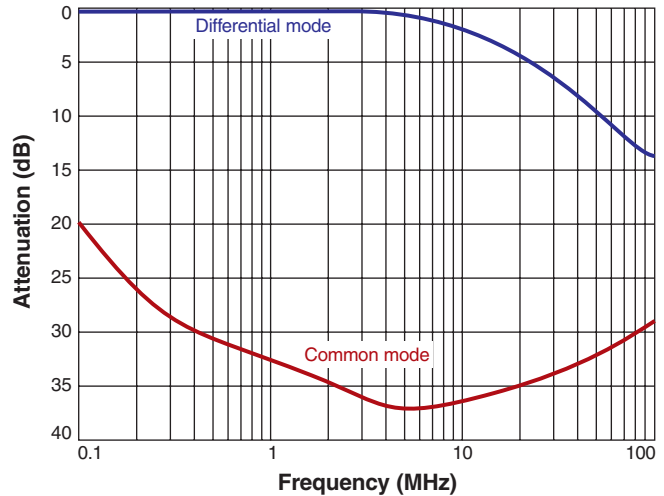

Typical Impedance versus Frequency

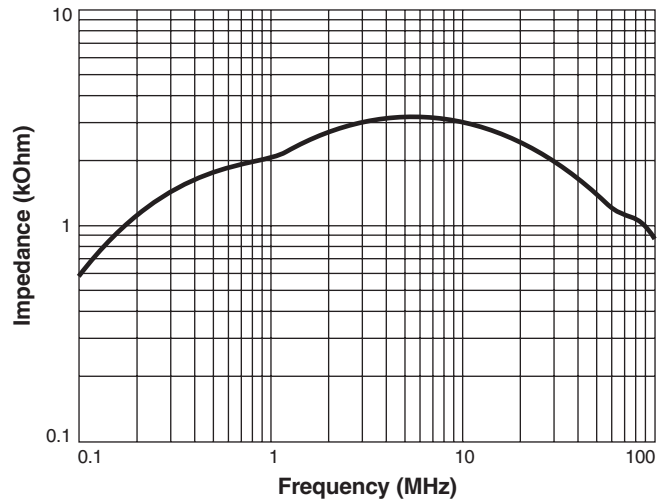

Core material Ferrite
Terminations RoHS compliant tin-silver-copper over copper
Weight 0.92 g
Ambient temperature -40°C to +85°C with I_{rms} current
Maximum part temperature +125°C (ambient + temp rise)
Storage temperature Component: -40°C to +125°C. Tape and reel packaging: -40°C to +80°C
Resistance to soldering heat Max three 40 second reflows at +260°C, parts cooled to room temperature between cycles
Moisture Sensitivity Level (MSL) 1 (unlimited floor life at <30°C / 85% relative humidity)
Packaging 600/13" reel Plastic tape: 24 mm wide, 0.4 mm thick, 16 mm pocket spacing, 5.5 mm pocket depth
PCB washing Tested to MIL-STD-202 Method 215 plus an additional aqueous wash. See [Doc787_PCB_Washing.pdf](#).



US +1-847-639-6400 sales@coilcraft.com
UK +44-1236-730595 sales@coilcraft-europe.com
Taiwan +886-2-2264 3646 sales@coilcraft.com.tw
China +86-21-6218 8074 sales@coilcraft.com.cn
Singapore + 65-6484 8412 sales@coilcraft.com.sg

Document 1194P-2 Revised 09/09/21

© Coilcraft Inc. 2021

This product may not be used in medical or high risk applications without prior Coilcraft approval. Specification subject to change without notice. Please check web site for latest information.



Common Mode Choke – CR7915-AL

Part number ¹	Common mode impedance max (kOhms)	Inductance (mH) ²		I _{rms} ³ (A)	DCR max ⁴ (mOhms)	Isolation ⁵ (Vrms)
		nom	min			
CR7915-AL_	3.10 @ 4.9 MHz	1.12	0.73	2.6	49.5	1500

1. When ordering, please specify **packaging** code:

CR7915-ALD

Packaging: **D** = 13" machine-ready reel. EIA-481 embossed plastic tape (600 parts per full reel). Quantities less than full reel available: in tape (not machine ready) or with leader and trailer (\$25 charge).

B = Less than full reel. In an effort to simplify our part numbering system, Coilcraft is eliminating the need for multiple packaging codes. When ordering, simply change the last letter of your part number from B to D.

- Inductance shown for each winding, measured at 10 kHz, 0.1 Vrms, 0 Adc on an Agilent/HP 4263B LCR meter or equivalent.
- Current per winding that causes a 40°C rise from 25°C ambient. This information is for reference only and does not represent absolute maximum ratings.
- DCR is specified per winding.
- Isolation (hipot) measured for two seconds.
- Electrical specifications at 25°C.

Refer to Doc 362 "Soldering Surface Mount Components" before soldering.

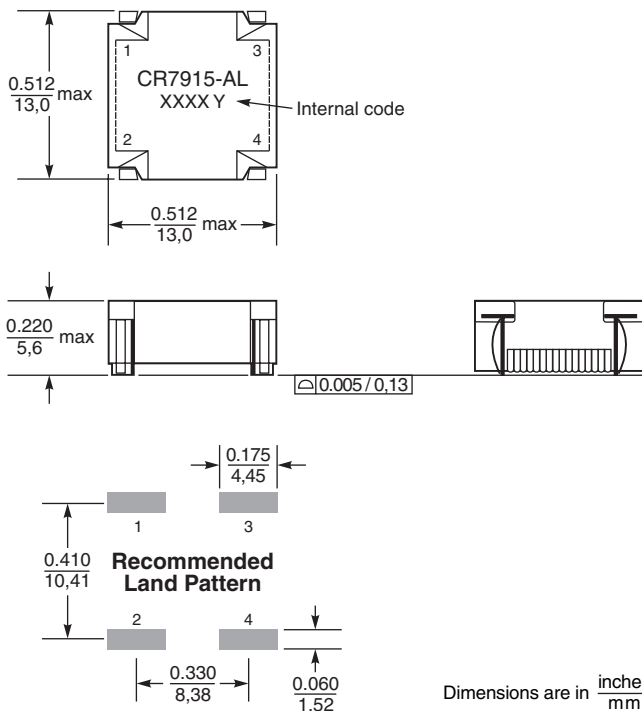

Dimensions are in inches/mm

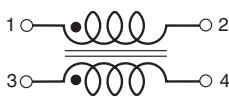

Typical Attenuation

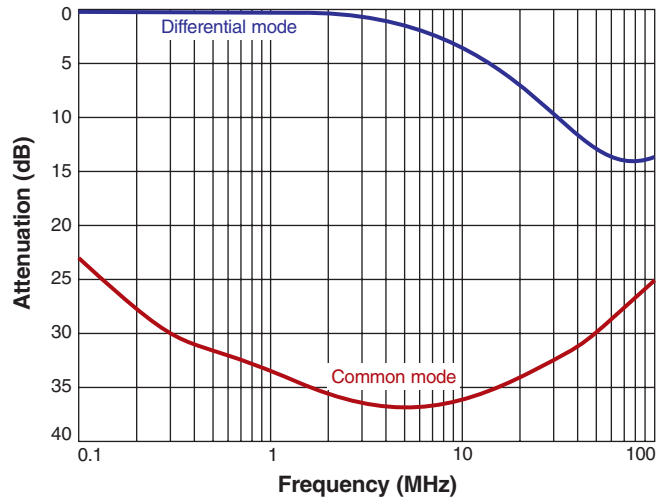

Typical Impedance versus Frequency

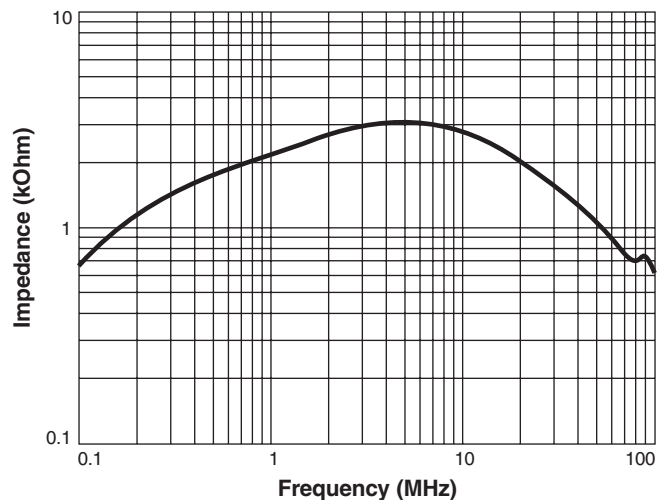

Core material Ferrite
Terminations RoHS compliant tin-silver-copper over copper
Weight 1.53 g
Ambient temperature -40°C to +85°C with I_{rms} current
Maximum part temperature +125°C (ambient + temp rise)
Storage temperature Component: -40°C to +125°C.
 Tape and reel packaging: -40°C to +80°C
Resistance to soldering heat Max three 40 second reflows at +260°C, parts cooled to room temperature between cycles
Moisture Sensitivity Level (MSL) 1 (unlimited floor life at <30°C / 85% relative humidity)
Packaging 600/13" reel Plastic tape: 24 mm wide, 0.4 mm thick, 16 mm pocket spacing, 5.5 mm pocket depth
PCB washing Tested to MIL-STD-202 Method 215 plus an additional aqueous wash. See [Doc787_PCB_Washing.pdf](#).



US +1-847-639-6400 sales@coilcraft.com
UK +44-1236-730595 sales@coilcraft-europe.com
Taiwan +886-2-2264 3646 sales@coilcraft.com.tw
China +86-21-6218 8074 sales@coilcraft.com.cn
Singapore + 65-6484 8412 sales@coilcraft.com.sg

Document 1194P-3 Revised 09/09/21

© Coilcraft Inc. 2021

This product may not be used in medical or high risk applications without prior Coilcraft approval. Specification subject to change without notice. Please check web site for latest information.



Common Mode Chokes – CF3094-AL

Part number ¹	Common mode impedance max (kOhms)	Inductance (mH) ²		I _{rms} ³ (A)	DCR max ⁴ (mOhms)	Isolation ⁵ (Vrms)
		nom	min			
CF3094-AL_	7.93 @ 2.5 MHz	1.17	0.76	1.1	200	1000

1. When ordering, please specify **packaging** code:

CF3094-ALD

Packaging: **D** = 13" machine-ready reel. EIA-481 embossed plastic tape (600 parts per full reel). Quantities less than full reel available: in tape (not machine ready) or with leader and trailer (\$25 charge).

B = Less than full reel. In an effort to simplify our part numbering system, Coilcraft is eliminating the need for multiple packaging codes. When ordering, simply change the last letter of your part number from B to D.

- Inductance shown for each winding, measured at 10 kHz, 0.1 Vrms, 0 Adc on an Agilent/HP 4263B LCR meter or equivalent.
- Current per winding that causes a 40°C rise from 25°C ambient. This information is for reference only and does not represent absolute maximum ratings.
- DCR is specified per winding.
- Isolation (hipot) measured for two seconds.
- Electrical specifications at 25°C.

Refer to Doc 362 "Soldering Surface Mount Components" before soldering.

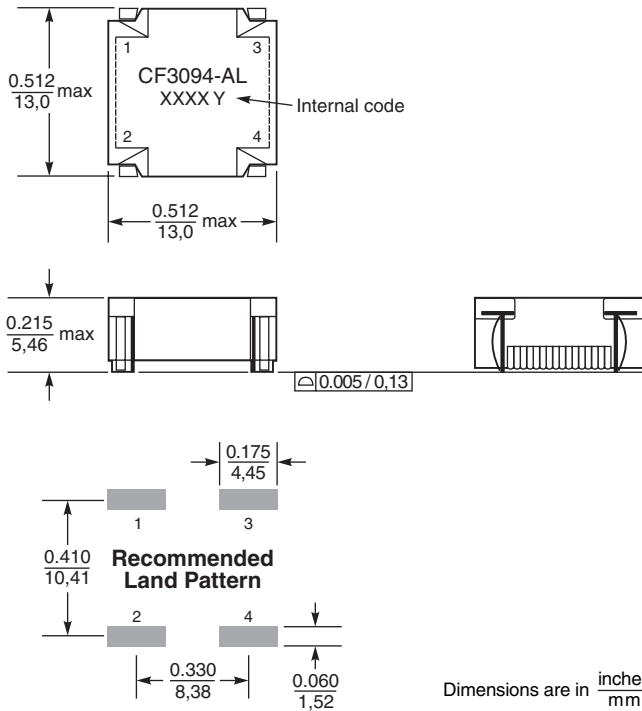

Dimensions are in $\frac{\text{inches}}{\text{mm}}$

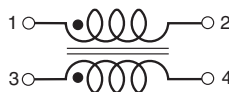

Typical Attenuation

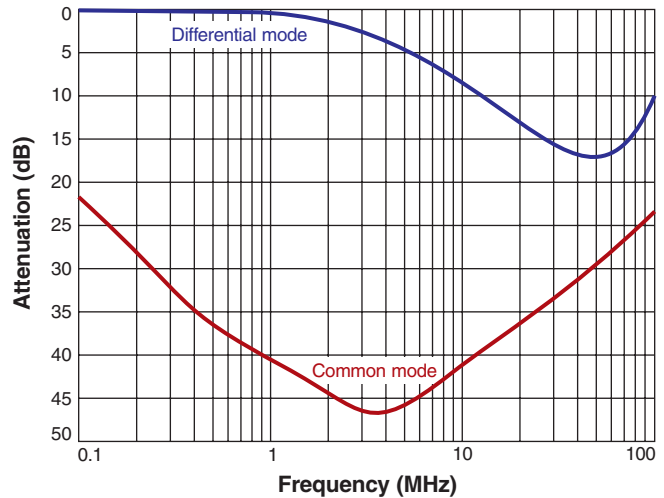

Typical Impedance versus Frequency

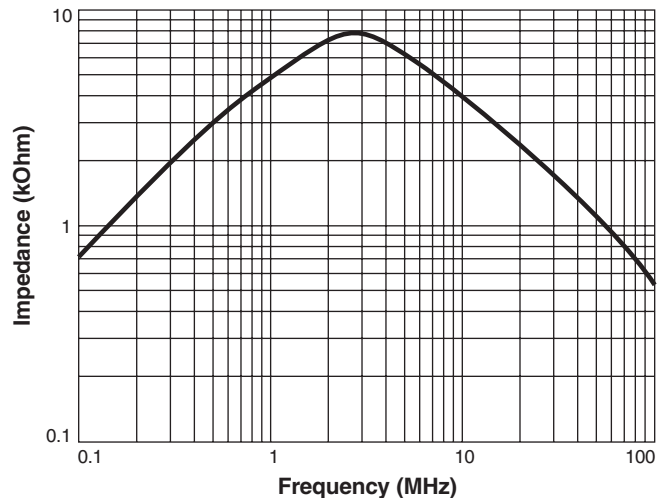

Core material Ferrite

Terminations RoHS compliant tin-silver-copper over copper

Weight 1.38 g

Ambient temperature -40°C to +85°C with I_{rms} current

Maximum part temperature +125°C (ambient + temp rise)

Storage temperature Component: -40°C to +125°C.

Tape and reel packaging: -40°C to +80°C

Resistance to soldering heat Max three 40 second reflows at +260°C, parts cooled to room temperature between cycles

Moisture Sensitivity Level (MSL) 1 (unlimited floor life at <30°C / 85% relative humidity)

Packaging 600/13" reel Plastic tape: 24 mm wide, 0.4 mm thick, 16 mm pocket spacing, 5.5 mm pocket depth

PCB washing Tested to MIL-STD-202 Method 215 plus an additional aqueous wash. See [Doc787_PCB_Washing.pdf](#).



US +1-847-639-6400 sales@coilcraft.com
UK +44-1236-730595 sales@coilcraft-europe.com
Taiwan +886-2-2264 3646 sales@coilcraft.com.tw
China +86-21-6218 8074 sales@coilcraft.com.cn
Singapore + 65-6484 8412 sales@coilcraft.com.sg

Document 1194P-4 Revised 09/09/21

© Coilcraft Inc. 2021

This product may not be used in medical or high risk applications without prior Coilcraft approval. Specification subject to change without notice. Please check web site for latest information.



Common Mode Choke – CM6518-AL

Part number ¹	Common mode impedance max (kOhms)	Inductance (mH) ²		I _{rms} ³ (A)	DCR max ⁴ (mOhms)	Isolation ⁵ (Vrms)
		nom	min			
CM6518-AL_	4.17 @ 1.9 MHz	1.40	0.91	2.5	60.0	1500

1. When ordering, please specify **packaging** code:

CM6518-ALD

Packaging: **D** = 13" machine-ready reel. EIA-481 embossed plastic tape (350 parts per full reel). Quantities less than full reel available: in tape (not machine ready) or with leader and trailer (\$25 charge).

B = Less than full reel. In an effort to simplify our part numbering system, Coilcraft is eliminating the need for multiple packaging codes. When ordering, simply change the last letter of your part number from B to D.

- Inductance shown for each winding, measured at 10 kHz, 0.1 Vrms, 0 Adc on an Agilent/HP 4263B LCR meter or equivalent.
- Current per winding that causes a 40°C rise from 25°C ambient. This information is for reference only and does not represent absolute maximum ratings.
- DCR is specified per winding.
- Isolation (hipot) measured for two seconds.
- Electrical specifications at 25°C.

Refer to Doc 362 "Soldering Surface Mount Components" before soldering.

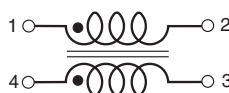
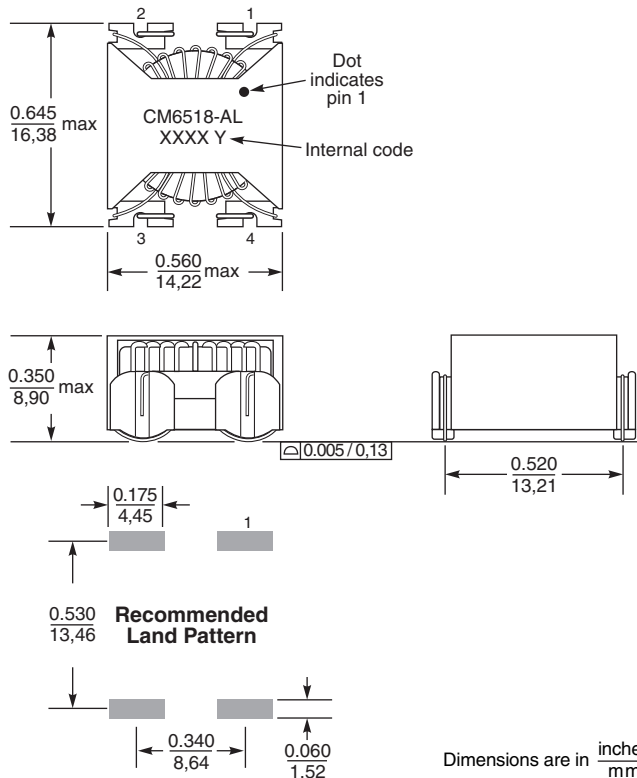

Typical Attenuation

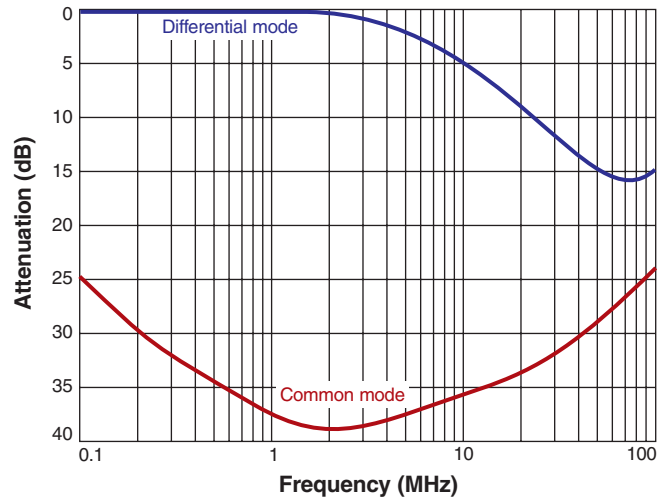

Typical Impedance versus Frequency

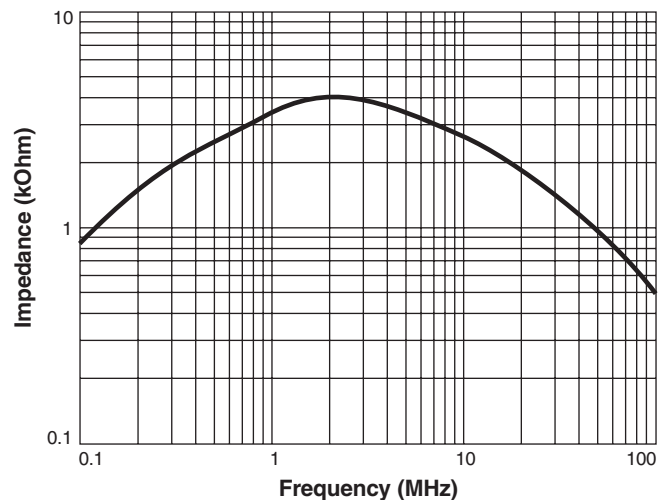

Core material Ferrite

Terminations RoHS compliant tin-silver-copper over copper

Weight 2.48 g

Ambient temperature -40°C to +85°C with I_{rms} current

Maximum part temperature +125°C (ambient + temp rise)

Storage temperature Component: -40°C to +125°C.

Tape and reel packaging: -40°C to +80°C

Resistance to soldering heat Max three 40 second reflows at +260°C, parts cooled to room temperature between cycles

Moisture Sensitivity Level (MSL) 1 (unlimited floor life at <30°C / 85% relative humidity)

Packaging 350/13" reel Plastic tape: 24 mm wide, 0.4 mm thick, 20 mm pocket spacing, 9.1 mm pocket depth

PCB washing Tested to MIL-STD-202 Method 215 plus an additional aqueous wash. See [Doc787_PCB_Washing.pdf](#).



Common Mode Choke – CJ5094-CL

Part number ¹	Common mode impedance max (kOhms)	Inductance (mH) ²		I _{rms} ³ (A)	DCR max ⁴ (mOhms)	Isolation ⁵ (Vrms)
		nom	min			
CJ5094-CL_	28.28 @ 0.26 MHz	10.0	6.5	1.2	180	1000

1. When ordering, please specify **packaging** code:

CJ5094-CLD

Packaging: **D** = 13" machine-ready reel. EIA-481 embossed plastic tape (350 parts per full reel). Quantities less than full reel available: in tape (not machine ready) or with leader and trailer (\$25 charge).

B = Less than full reel. In an effort to simplify our part numbering system, Coilcraft is eliminating the need for multiple packaging codes. When ordering, simply change the last letter of your part number from B to D.

- Inductance shown for each winding, measured at 10 kHz, 0.1 Vrms, 0 Adc on an Agilent/HP 4263B LCR meter or equivalent.
- Current per winding that causes a 40°C rise from 25°C ambient. This information is for reference only and does not represent absolute maximum ratings.
- DCR is specified per winding.
- Isolation (hipot) measured for two seconds.
- Electrical specifications at 25°C.

Refer to Doc 362 "Soldering Surface Mount Components" before soldering.

Typical Attenuation

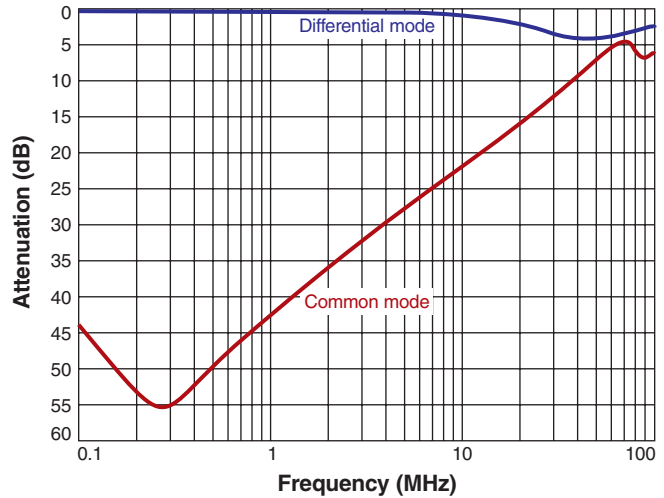

Typical Impedance versus Frequency

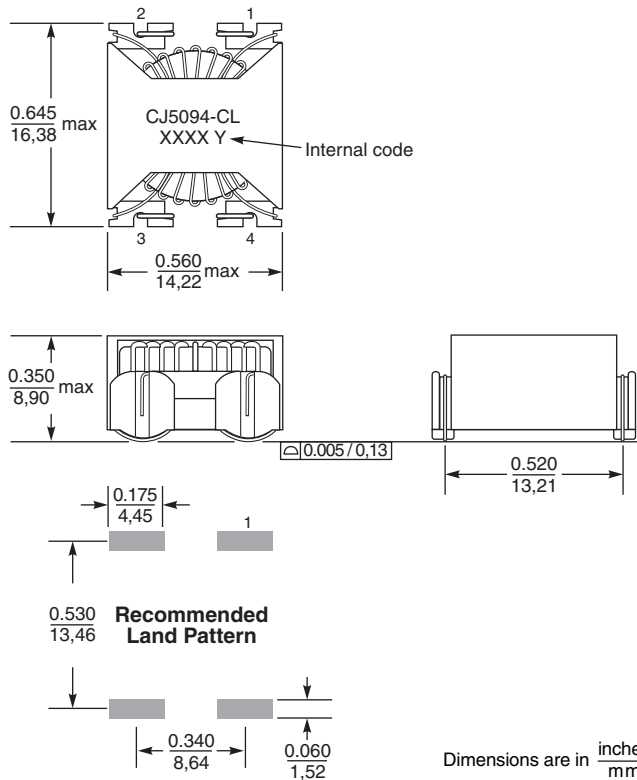
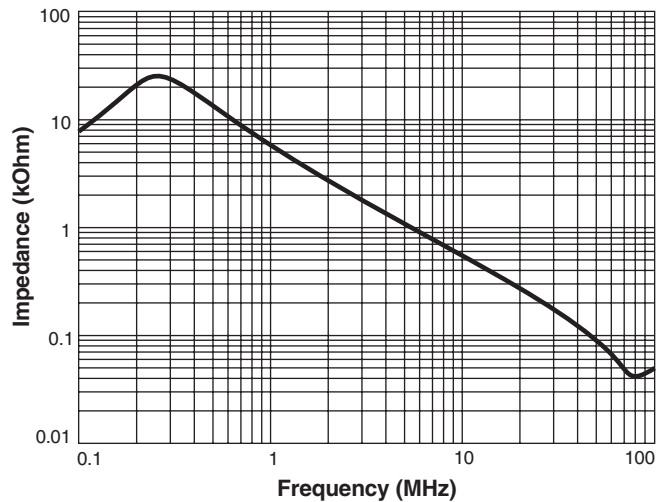

Core material Ferrite

Terminations RoHS compliant tin-silver-copper over copper

Weight 2.9 g

Ambient temperature -40°C to +85°C with I_{rms} current

Maximum part temperature +125°C (ambient + temp rise)

Storage temperature Component: -40°C to +125°C.

Tape and reel packaging: -40°C to +80°C

Resistance to soldering heat Max three 40 second reflows at +260°C, parts cooled to room temperature between cycles

Moisture Sensitivity Level (MSL) 1 (unlimited floor life at <30°C / 85% relative humidity)

Packaging 350/13" reel Plastic tape: 24 mm wide, 0.4 mm thick, 24 mm pocket spacing, 8.6 mm pocket depth

PCB washing Tested to MIL-STD-202 Method 215 plus an additional aqueous wash. See [Doc787_PCB_Washing.pdf](#).



US +1-847-639-6400 sales@coilcraft.com
UK +44-1236-730595 sales@coilcraft-europe.com
Taiwan +886-2-2264 3646 sales@coilcraft.com.tw
China +86-21-6218 8074 sales@coilcraft.com.cn
Singapore + 65-6484 8412 sales@coilcraft.com.sg

Document 1194P-6 Revised 09/09/21

© Coilcraft Inc. 2021

This product may not be used in medical or high risk applications without prior Coilcraft approval. Specification subject to change without notice. Please check web site for latest information.



Common Mode Choke – CV9172-AL

Part number ¹	Common mode impedance max (kOhms)	Inductance (mH) ²		I _{rms} ³ (A)	DCR max ⁴ (mOhms)	Isolation ⁵ (Vrms)
		nom	min			
CV9172-AL_	70.01 @ 0.21 MHz	22.0	14.3	0.57	850	1000

1. When ordering, please specify **packaging** code:

CV9172-ALD

Packaging: **D** = 13" machine-ready reel. EIA-481 embossed plastic tape (350 parts per full reel). Quantities less than full reel available: in tape (not machine ready) or with leader and trailer (\$25 charge).

B = Less than full reel. In an effort to simplify our part numbering system, Coilcraft is eliminating the need for multiple packaging codes. When ordering, simply change the last letter of your part number from B to D.

- Inductance shown for each winding, measured at 10 kHz, 1.0 Vrms, 0 Adc on an Agilent/HP 4263B LCR meter or equivalent.
- Current per winding that causes a 40°C rise from 25°C ambient. This information is for reference only and does not represent absolute maximum ratings.
- DCR is specified per winding.
- Isolation (hipot) measured for two seconds.
- Electrical specifications at 25°C.

Refer to Doc 362 "Soldering Surface Mount Components" before soldering.

Typical Attenuation

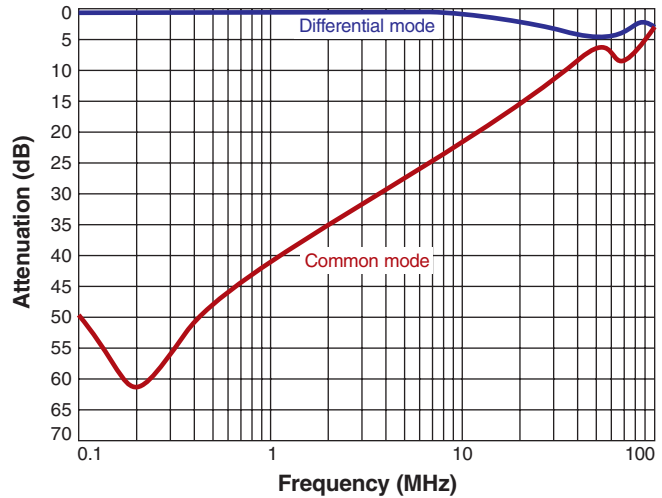

Typical Impedance versus Frequency

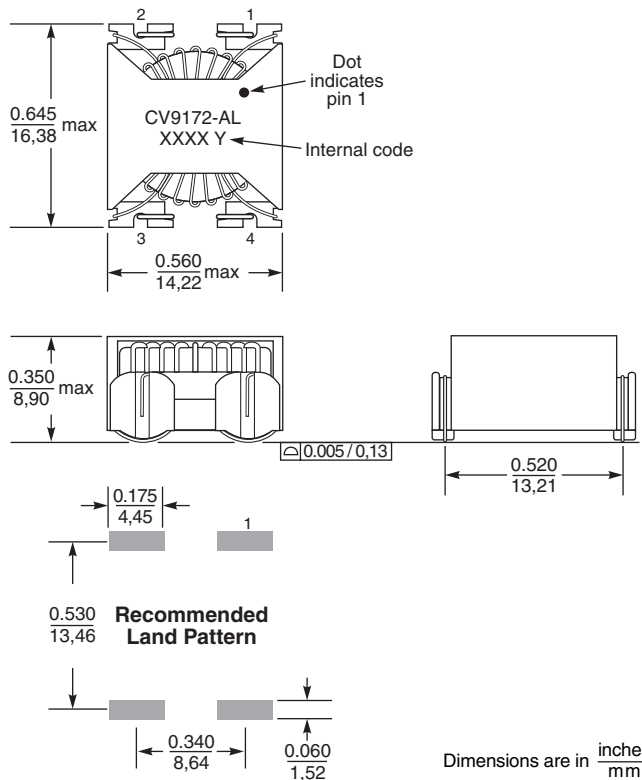
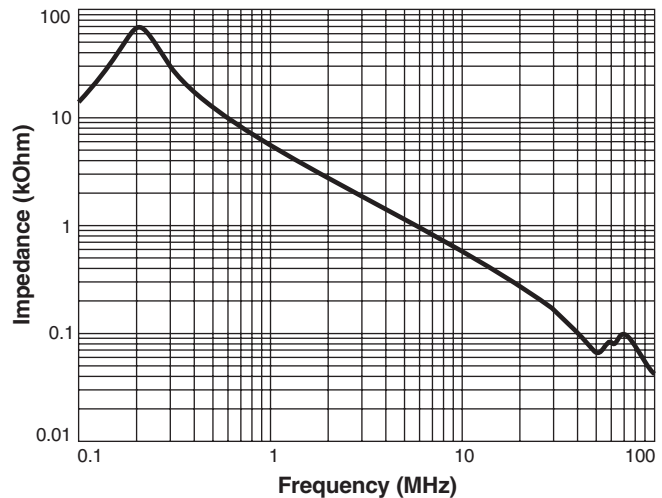

Core material Ferrite

Terminations RoHS compliant tin-silver-copper over copper

Weight 2.4 g

Ambient temperature -40°C to +85°C with I_{rms} current

Maximum part temperature +125°C (ambient + temp rise)

Storage temperature Component: -40°C to +125°C.

Tape and reel packaging: -40°C to +80°C

Resistance to soldering heat Max three 40 second reflows at +260°C, parts cooled to room temperature between cycles

Moisture Sensitivity Level (MSL) 1 (unlimited floor life at <30°C / 85% relative humidity)

Packaging 350/13" reel Plastic tape: 24 mm wide, 0.4 mm thick, 20 mm pocket spacing, 9.1 mm pocket depth

PCB washing Tested to MIL-STD-202 Method 215 plus an additional aqueous wash. See [Doc787_PCB_Washing.pdf](#).



US +1-847-639-6400 sales@coilcraft.com
UK +44-1236-730595 sales@coilcraft-europe.com
Taiwan +886-2-2264 3646 sales@coilcraft.com.tw
China +86-21-6218 8074 sales@coilcraft.com.cn
Singapore + 65-6484 8412 sales@coilcraft.com.sg

Document 1194P-7 Revised 09/09/21

© Coilcraft Inc. 2021

This product may not be used in medical or high risk applications without prior Coilcraft approval. Specification subject to change without notice. Please check web site for latest information.



Common Mode Choke – CF2638L

Part number ¹	Common mode impedance max (kOhms)	Inductance (mH) ²		I _{rms} ³ (A)	DCR max ⁴ (mOhms)	Isolation ⁵ (Vrms)
		nom	min			
CF2638LD	2.59 @ 4.3 MHz	0.22	0.14	2.9	60.0	1000

1. When ordering, please specify **packaging** code:

CF2638LD

Packaging: **D** = 13" machine-ready reel. EIA-481 embossed plastic tape (250 parts per full reel). Quantities less than full reel available: in tape (not machine ready) or with leader and trailer (\$25 charge).

B = Less than full reel. In an effort to simplify our part numbering system, Coilcraft is eliminating the need for multiple packaging codes. When ordering, simply change the last letter of your part number from B to D.

- 2. Inductance shown for each winding, measured at 10 kHz, 1.0 Vrms, 0 Adc on an Agilent/HP 4263B LCR meter or equivalent.
- 3. Current per winding that causes a 40°C rise from 25°C ambient. This information is for reference only and does not represent absolute maximum ratings.
- 4. DCR is specified per winding.
- 5. Isolation (hipot) measured for two seconds.
- 6. Electrical specifications at 25°C.

Refer to Doc 362 "Soldering Surface Mount Components" before soldering.

Typical Attenuation

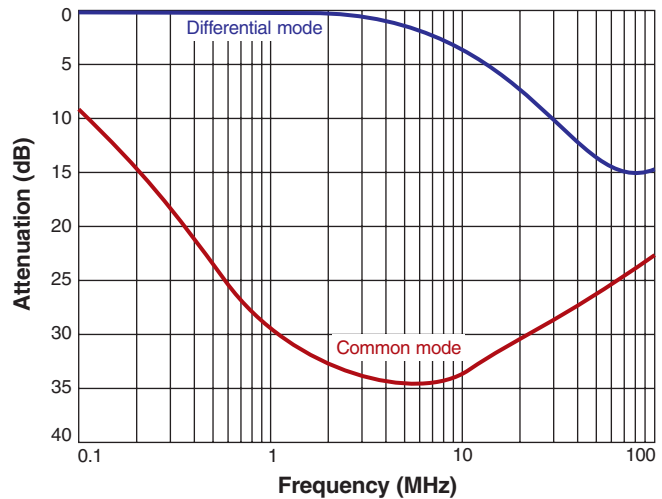

Typical Impedance versus Frequency

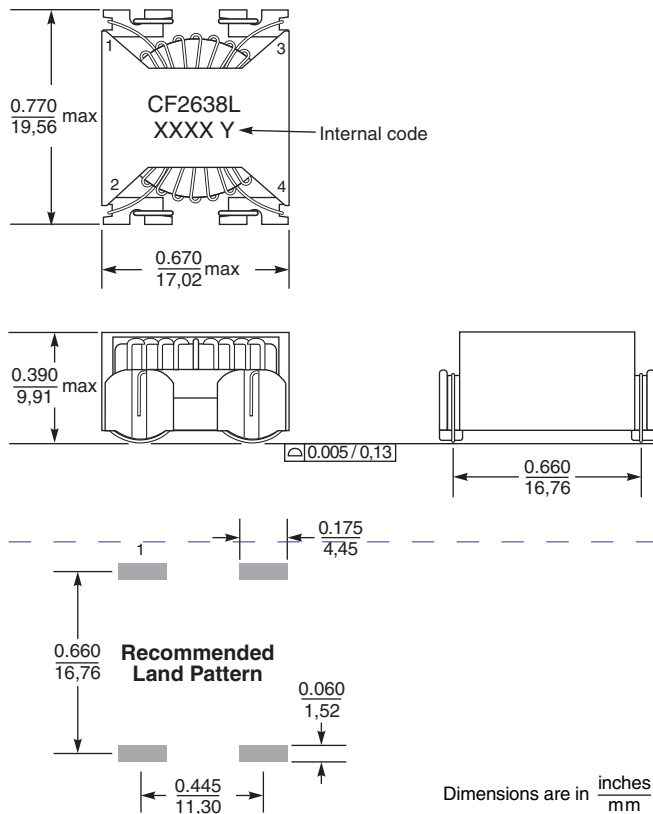
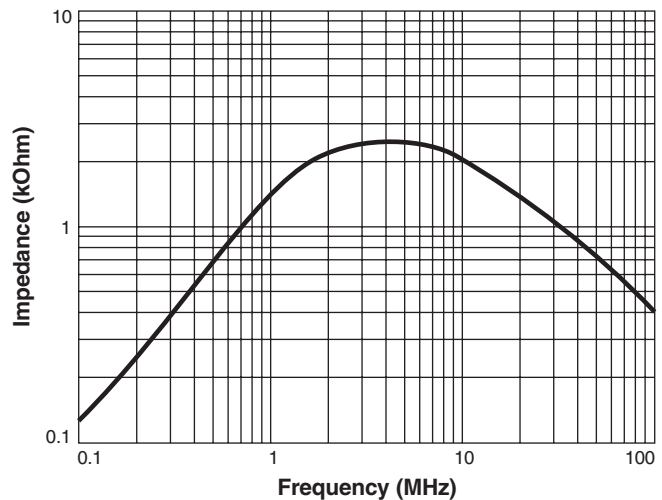

Core material Ferrite
Terminations RoHS compliant tin-silver-copper over copper
Weight 3.2 g
Ambient temperature -40°C to +85°C with I_{rms} current
Maximum part temperature +125°C (ambient + temp rise)
Storage temperature Component: -40°C to +125°C.
 Tape and reel packaging: -40°C to +80°C
Resistance to soldering heat Max three 40 second reflows at +260°C, parts cooled to room temperature between cycles
Moisture Sensitivity Level (MSL) 1 (unlimited floor life at <30°C / 85% relative humidity)
Packaging 250/13" reel Plastic tape: 32 mm wide, 0.5 mm thick, 24 mm pocket spacing, 10.1 mm pocket depth
PCB washing Tested to MIL-STD-202 Method 215 plus an additional aqueous wash. See [Doc787_PCB_Washing.pdf](#).

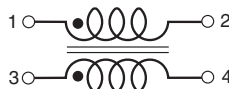



Common Mode Choke – CD1479-AL

Part number ¹	Common mode impedance max (kOhms)	Inductance (mH) ²		I _{rms} ³ (A)	DCR max ⁴ (mOhms)	Isolation ⁵ (Vrms)
		nom	min			
CD1479-AL_	4.19 @ 3.0 MHz	0.59	0.38	4.2	20.0	1000

1. When ordering, please specify **packaging** code:

CD1479-ALD

Packaging: **D** = 13" machine-ready reel. EIA-481 embossed plastic tape (250 parts per full reel). Quantities less than full reel available: in tape (not machine ready) or with leader and trailer (\$25 charge).

B = Less than full reel. In an effort to simplify our part numbering system, Coilcraft is eliminating the need for multiple packaging codes. When ordering, simply change the last letter of your part number from B to D.

- Inductance shown for each winding, measured at 10 kHz, 0.1 Vrms, 0 Adc on an Agilent/HP 4263B LCR meter or equivalent.
- Current per winding that causes a 40°C rise from 25°C ambient. This information is for reference only and does not represent absolute maximum ratings.
- DCR is specified per winding.
- Isolation (hipot) measured for two seconds.
- Electrical specifications at 25°C.

Refer to Doc 362 "Soldering Surface Mount Components" before soldering.

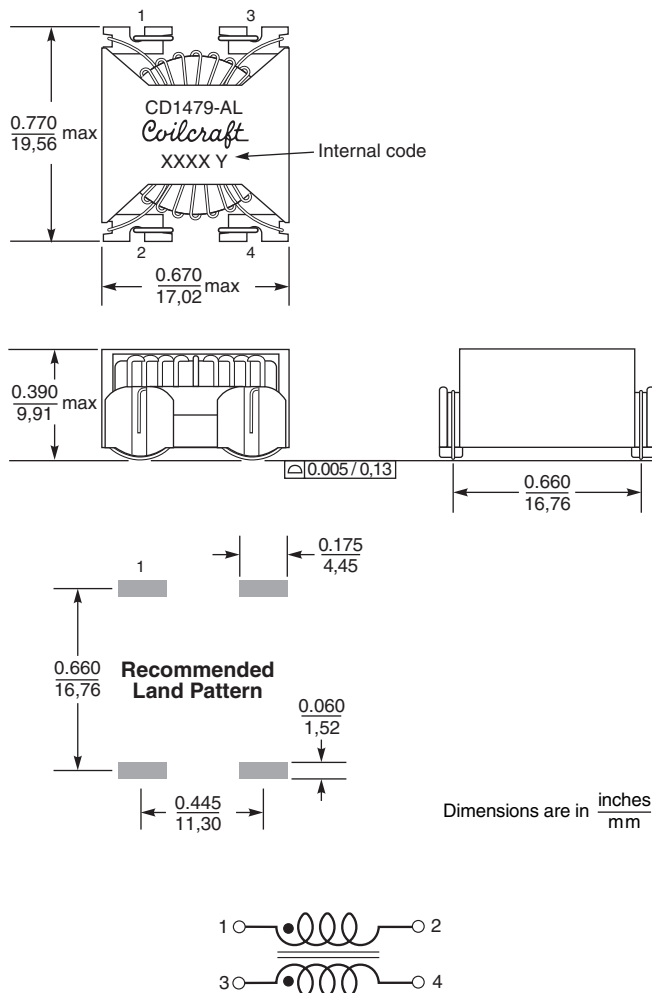

Typical Attenuation

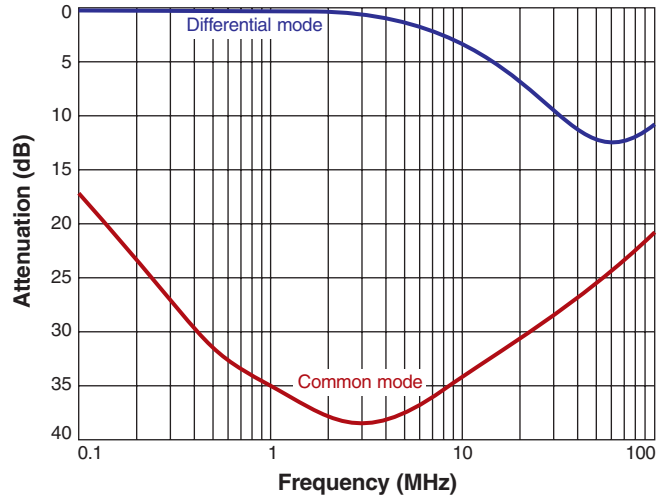

Typical Impedance versus Frequency

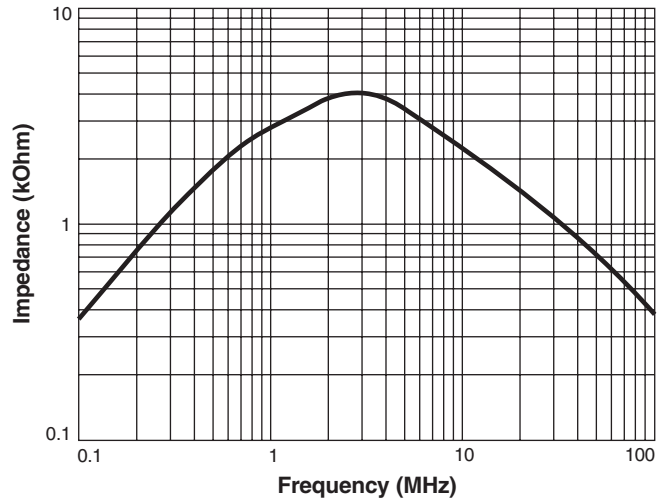

Core material Ferrite
Terminations RoHS compliant tin-silver-copper over copper
Weight 4.9 g
Ambient temperature -40°C to +85°C with I_{rms} current
Maximum part temperature +125°C (ambient + temp rise)
Storage temperature Component: -40°C to +125°C. Tape and reel packaging: -40°C to +80°C
Resistance to soldering heat Max three 40 second reflows at +260°C, parts cooled to room temperature between cycles
Moisture Sensitivity Level (MSL) 1 (unlimited floor life at <30°C / 85% relative humidity)
Packaging 250/13" reel Plastic tape: 32 mm wide, 0.5 mm thick, 24 mm pocket spacing, 10.1 mm pocket depth
PCB washing Tested to MIL-STD-202 Method 215 plus an additional aqueous wash. See [Doc787_PCB_Washing.pdf](#).



US +1-847-639-6400 sales@coilcraft.com
UK +44-1236-730595 sales@coilcraft-europe.com
Taiwan +886-2-2264 3646 sales@coilcraft.com.tw
China +86-21-6218 8074 sales@coilcraft.com.cn
Singapore + 65-6484 8412 sales@coilcraft.com.sg

Document 1194P-9 Revised 09/09/21

© Coilcraft Inc. 2021

This product may not be used in medical or high risk applications without prior Coilcraft approval. Specification subject to change without notice. Please check web site for latest information.



Common Mode Choke – CH4659-AL

Part number ¹	Common mode impedance max (kOhms)	Inductance (mH) ²		I _{rms} ³ (A)	DCR max ⁴ (mOhms)	Isolation ⁵ (Vrms)
		nom	min			
CH4659-AL_	4.56 @ 2.5 MHz	0.77	0.50	4.7	40.0	1000

1. When ordering, please specify **packaging** code:

CH4659-ALD

Packaging: **D** = 13" machine-ready reel. EIA-481 embossed plastic tape (250 parts per full reel). Quantities less than full reel available: in tape (not machine ready) or with leader and trailer (\$25 charge).

B = Less than full reel. In an effort to simplify our part numbering system, Coilcraft is eliminating the need for multiple packaging codes. When ordering, simply change the last letter of your part number from B to D.

- Inductance shown for each winding, measured at 10 kHz, 1.0 Vrms, 0 Adc on an Agilent/HP 4263B LCR meter or equivalent.
- Current per winding that causes a 40°C rise from 25°C ambient. This information is for reference only and does not represent absolute maximum ratings.
- DCR is specified per winding.
- Isolation (hipot) measured for two seconds.
- Electrical specifications at 25°C.

Refer to Doc 362 "Soldering Surface Mount Components" before soldering.

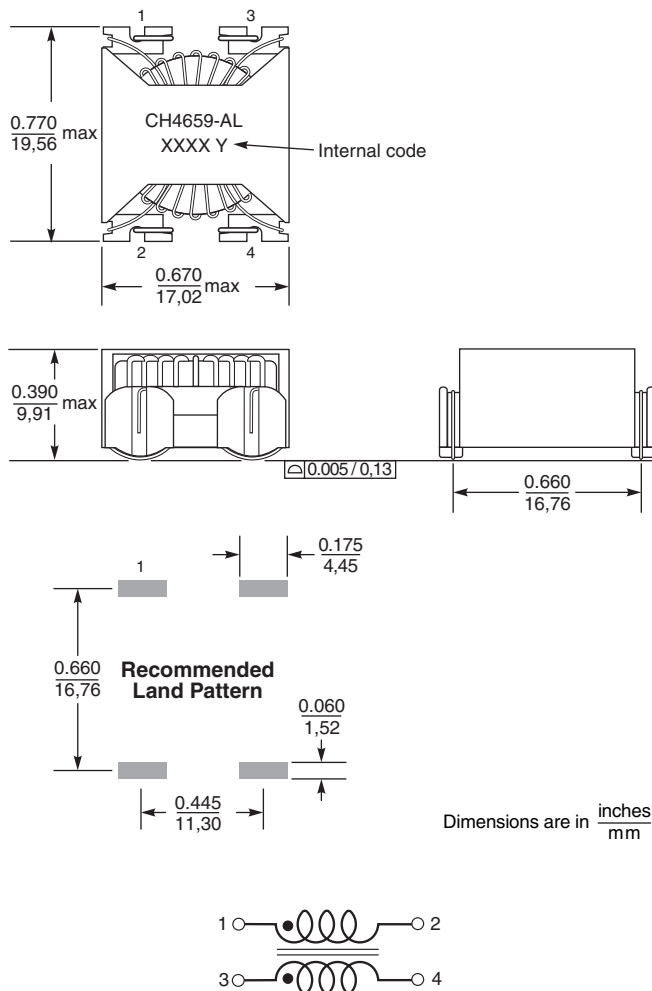

Typical Attenuation

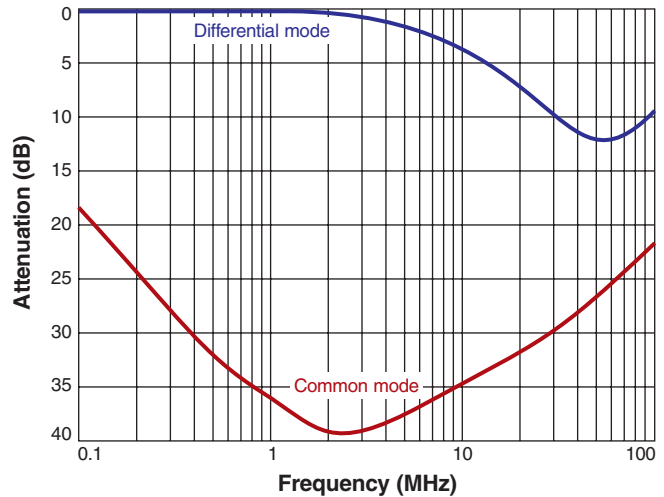

Typical Impedance versus Frequency

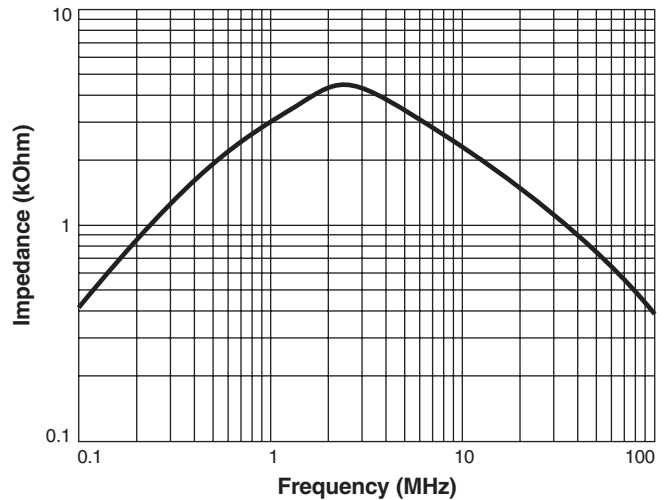

Core material Ferrite
Terminations RoHS compliant tin-silver-copper over copper
Weight 4.8 g
Ambient temperature -40°C to +85°C with I_{rms} current
Maximum part temperature +125°C (ambient + temp rise)
Storage temperature Component: -40°C to +125°C. Tape and reel packaging: -40°C to +80°C
Resistance to soldering heat Max three 40 second reflows at +260°C, parts cooled to room temperature between cycles
Moisture Sensitivity Level (MSL) 1 (unlimited floor life at <30°C / 85% relative humidity)
Packaging 250/13" reel Plastic tape: 32 mm wide, 0.5 mm thick, 24 mm pocket spacing, 10.1 mm pocket depth
PCB washing Tested to MIL-STD-202 Method 215 plus an additional aqueous wash. See [Doc787_PCB_Washing.pdf](#).



US +1-847-639-6400 sales@coilcraft.com
UK +44-1236-730595 sales@coilcraft-europe.com
Taiwan +886-2-2264 3646 sales@coilcraft.com.tw
China +86-21-6218 8074 sales@coilcraft.com.cn
Singapore + 65-6484 8412 sales@coilcraft.com.sg

Document 1194P-10 Revised 09/09/21

© Coilcraft Inc. 2021
 This product may not be used in medical or high risk applications without prior Coilcraft approval. Specification subject to change without notice. Please check web site for latest information.



Common Mode Choke – CD1480-BL

Part number ¹	Common mode impedance max (kOhms)	Inductance (mH) ²		I _{rms} ³ (A)	DCR max ⁴ (mOhms)	Isolation ⁵ (Vrms)
		nom	min			
CD1480-BL_	4.53 @ 2.2 MHz	1.32	0.85	3.5	60.0	1000

1. When ordering, please specify **packaging** code:

CD1480-BLD

Packaging: **D** = 13" machine-ready reel. EIA-481 embossed plastic tape (250 parts per full reel). Quantities less than full reel available: in tape (not machine ready) or with leader and trailer (\$25 charge).

B = Less than full reel. In an effort to simplify our part numbering system, Coilcraft is eliminating the need for multiple packaging codes. When ordering, simply change the last letter of your part number from B to D.

- 2. Inductance shown for each winding, measured at 1 kHz, 0.1 Vrms, 0 Adc on an Agilent/HP 4263B LCR meter or equivalent.
- 3. Current per winding that causes a 40°C rise from 25°C ambient. This information is for reference only and does not represent absolute maximum ratings.
- 4. DCR is specified per winding.
- 5. Isolation (hipot) measured for two seconds.
- 6. Electrical specifications at 25°C.

Refer to Doc 362 "Soldering Surface Mount Components" before soldering.

Typical Attenuation

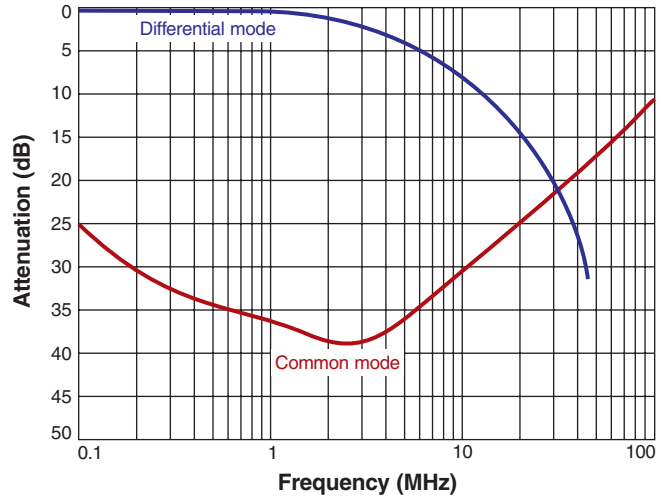

Typical Impedance versus Frequency

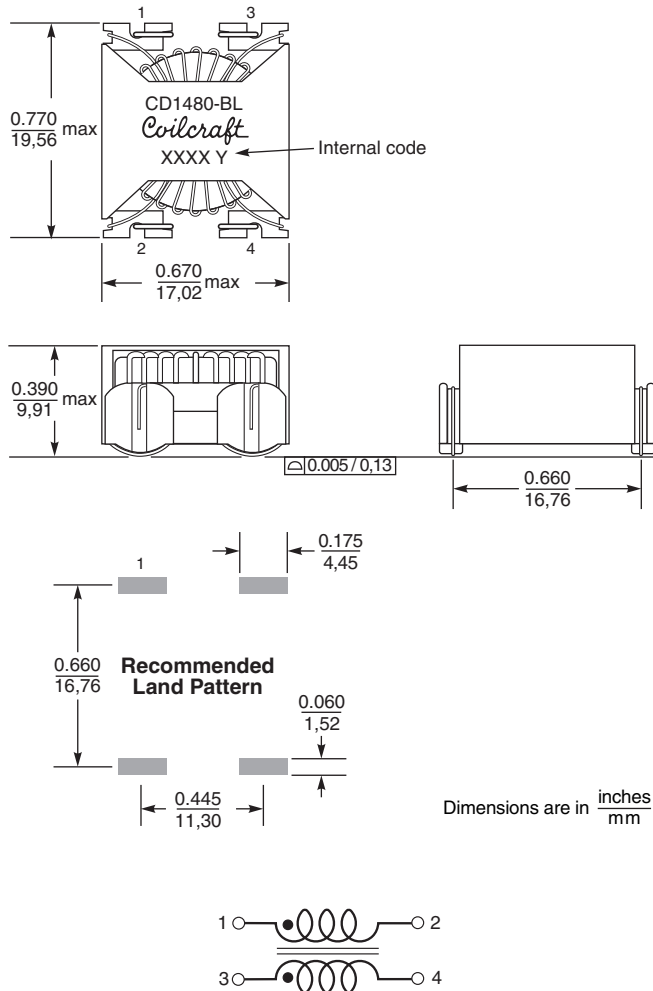
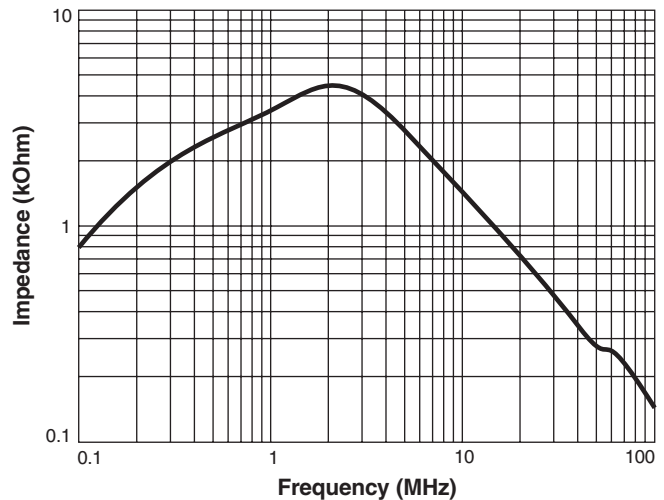

Core material Ferrite
Terminations RoHS compliant tin-silver-copper over copper
Weight 4.5 g
Ambient temperature -40°C to +85°C with I_{rms} current
Maximum part temperature +125°C (ambient + temp rise)
Storage temperature Component: -40°C to +125°C. Tape and reel packaging: -40°C to +80°C
Resistance to soldering heat Max three 40 second reflows at +260°C, parts cooled to room temperature between cycles
Moisture Sensitivity Level (MSL) 1 (unlimited floor life at <30°C / 85% relative humidity)
Packaging 250/13" reel Plastic tape: 32 mm wide, 0.5 mm thick, 24 mm pocket spacing, 10.1 mm pocket depth
PCB washing Tested to MIL-STD-202 Method 215 plus an additional aqueous wash. See [Doc787_PCB_Washing.pdf](#).



US +1-847-639-6400 sales@coilcraft.com
UK +44-1236-730595 sales@coilcraft-europe.com
Taiwan +886-2-2264 3646 sales@coilcraft.com.tw
China +86-21-6218 8074 sales@coilcraft.com.cn
Singapore + 65-6484 8412 sales@coilcraft.com.sg

Document 1194P-11 Revised 09/09/21
 © Coilcraft Inc. 2021
 This product may not be used in medical or high risk applications without prior Coilcraft approval. Specification subject to change without notice. Please check web site for latest information.



Common Mode Choke – CE2439L

Part number ¹	Common mode impedance max (kOhms)	Inductance (mH) ²		I _{rms} ³ (A)	DCR max ⁴ (mOhms)	Isolation ⁵ (Vrms)
		nom	min			
CE2439L_	9.42 @ 1.1 MHz	1.47	0.96	2.5	80.0	1000

1. When ordering, please specify **packaging** code:

CE2439LD

Packaging: **D** = 13" machine-ready reel. EIA-481 embossed plastic tape (250 parts per full reel). Quantities less than full reel available: in tape (not machine ready) or with leader and trailer (\$25 charge).

B = Less than full reel. In an effort to simplify our part numbering system, Coilcraft is eliminating the need for multiple packaging codes. When ordering, simply change the last letter of your part number from B to D.

- Inductance shown for each winding, measured at 1 kHz, 0.1 Vrms, 0 Adc on an Agilent/HP 4263B LCR meter or equivalent.
- Current per winding that causes a 40°C rise from 25°C ambient. This information is for reference only and does not represent absolute maximum ratings.
- DCR is specified per winding.
- Isolation (hipot) measured for two seconds.
- Electrical specifications at 25°C.

Refer to Doc 362 "Soldering Surface Mount Components" before soldering.

Typical Attenuation

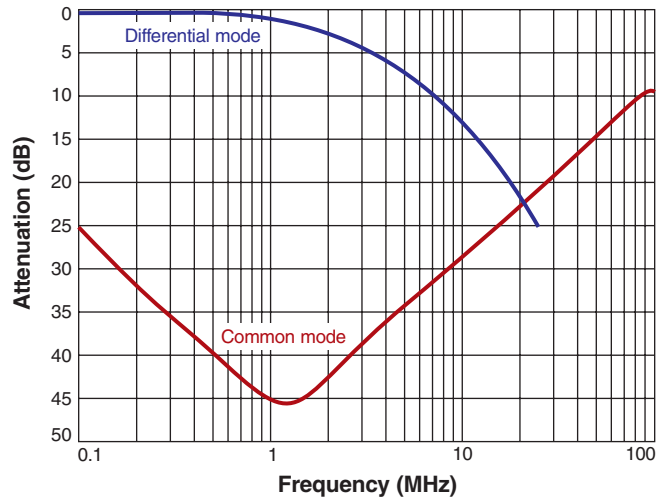

Typical Impedance versus Frequency

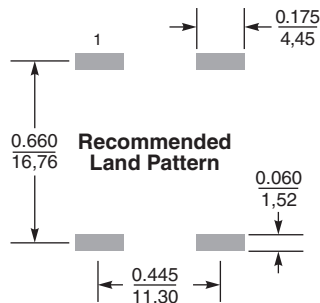
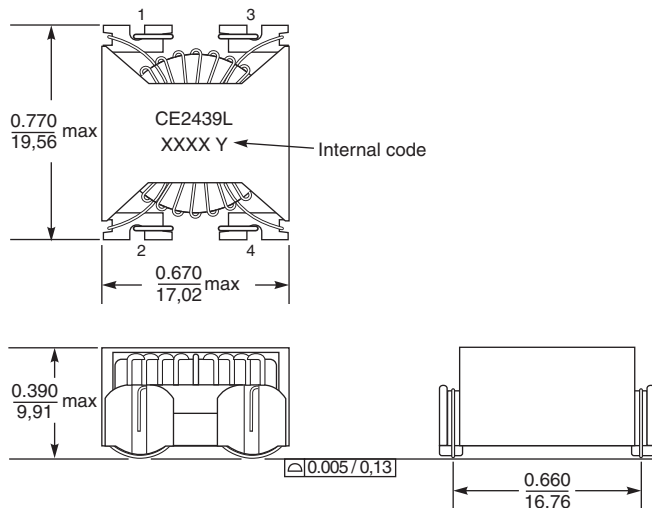
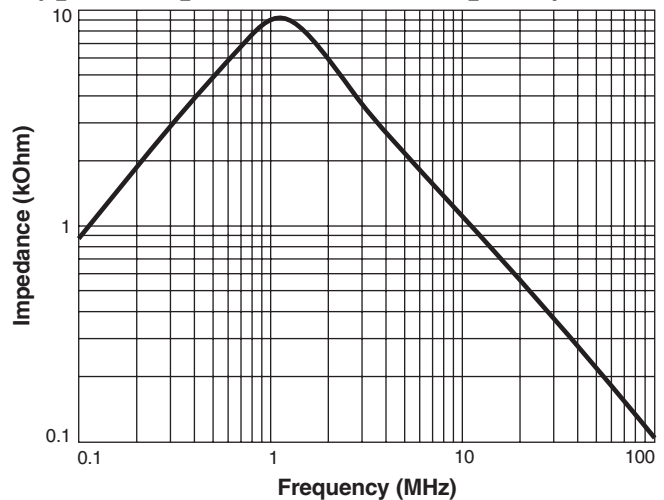

Dimensions are in $\frac{\text{inches}}{\text{mm}}$

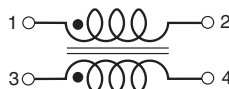

Core material Ferrite

Terminations RoHS compliant tin-silver-copper over copper

Weight 4.3 g

Ambient temperature -40°C to +85°C with I_{rms} current

Maximum part temperature +125°C (ambient + temp rise)

Storage temperature Component: -40°C to +125°C.

Tape and reel packaging: -40°C to +80°C

Resistance to soldering heat Max three 40 second reflows at +260°C, parts cooled to room temperature between cycles

Moisture Sensitivity Level (MSL) 1 (unlimited floor life at <30°C / 85% relative humidity)

Packaging 250/13" reel Plastic tape: 32 mm wide, 0.5 mm thick, 24 mm pocket spacing, 10.1 mm pocket depth

PCB washing Tested to MIL-STD-202 Method 215 plus an additional aqueous wash. See [Doc787_PCB_Washing.pdf](#).



www.coilcraft.com

US +1-847-639-6400 sales@coilcraft.com
UK +44-1236-730595 sales@coilcraft-europe.com
Taiwan +886-2-2264 3646 sales@coilcraft.com.tw
China +86-21-6218 8074 sales@coilcraft.com.cn
Singapore + 65-6484 8412 sales@coilcraft.com.sg

Document 1194P-12 Revised 09/09/21

© Coilcraft Inc. 2021

This product may not be used in medical or high risk applications without prior Coilcraft approval. Specification subject to change without notice. Please check web site for latest information.



Common Mode Chokes – CG3333-AL

Part number ¹	Common mode impedance max (kOhms)	Inductance (mH) ²		I _{rms} ³ (A)	DCR max ⁴ (mOhms)	Isolation ⁵ (Vrms)
		nom	min			
CG3333-AL	2.27 @ 2.9 MHz	0.90	0.59	3.7	50.0	1000

1. When ordering, please specify **packaging** code:

CG3333-ALD

Packaging: **D** = 13" machine-ready reel. EIA-481 embossed plastic tape (250 parts per full reel). Quantities less than full reel available: in tape (not machine ready) or with leader and trailer (\$25 charge).

B = Less than full reel. In an effort to simplify our part numbering system, Coilcraft is eliminating the need for multiple packaging codes. When ordering, simply change the last letter of your part number from B to D.

- 2. Inductance shown for each winding, measured at 10 kHz, 0.1 Vrms, 0 Adc on an Agilent/HP 4263B LCR meter or equivalent.
- 3. Current per winding that causes a 40°C rise from 25°C ambient. This information is for reference only and does not represent absolute maximum ratings.
- 4. DCR is specified per winding.
- 5. Isolation (hipot) measured for two seconds.
- 6. Electrical specifications at 25°C.

Refer to Doc 362 "Soldering Surface Mount Components" before soldering.

Typical Attenuation

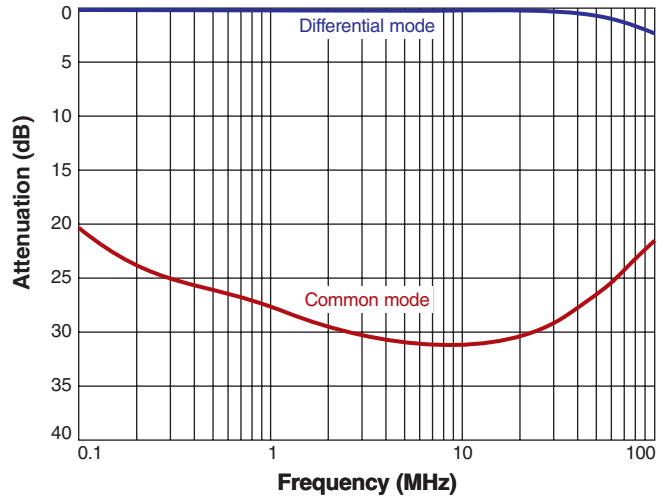

Typical Impedance versus Frequency

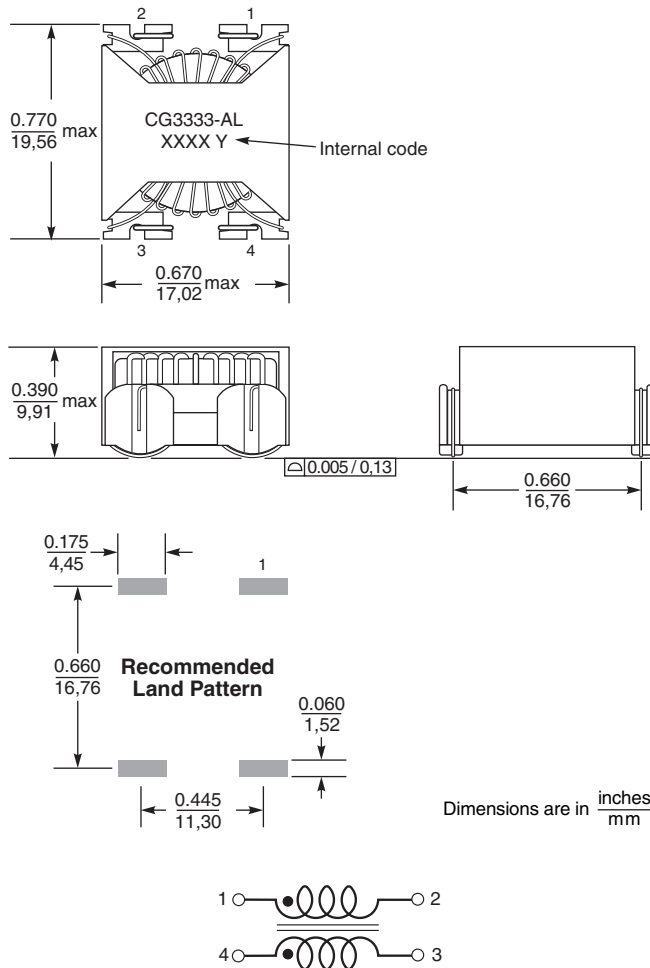
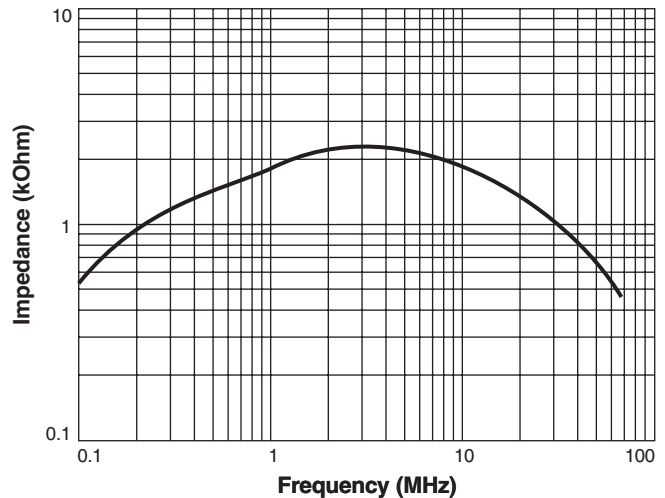

Core material Ferrite
Terminations RoHS compliant tin-silver-copper over copper
Weight 4.2 g
Ambient temperature -40°C to +85°C with I_{rms} current
Maximum part temperature +125°C (ambient + temp rise)
Storage temperature Component: -40°C to +125°C. Tape and reel packaging: -40°C to +80°C
Resistance to soldering heat Max three 40 second reflows at +260°C, parts cooled to room temperature between cycles
Moisture Sensitivity Level (MSL) 1 (unlimited floor life at <30°C / 85% relative humidity)
Packaging 250/13" reel Plastic tape: 32 mm wide, 0.5 mm thick, 24 mm pocket spacing, 10.1 mm pocket depth
PCB washing Tested to MIL-STD-202 Method 215 plus an additional aqueous wash. See [Doc787_PCB_Washing.pdf](#).



US +1-847-639-6400 sales@coilcraft.com
UK +44-1236-730595 sales@coilcraft-europe.com
Taiwan +886-2-2264 3646 sales@coilcraft.com.tw
China +86-21-6218 8074 sales@coilcraft.com.cn
Singapore + 65-6484 8412 sales@coilcraft.com.sg

Document 1194P-13 Revised 09/09/21

© Coilcraft Inc. 2021
 This product may not be used in medical or high risk applications without prior Coilcraft approval. Specification subject to change without notice. Please check web site for latest information.



Common Mode Chokes – CG3528-AL

Part number ¹	Common mode impedance max (kOhms)	Inductance (mH) ²		I _{rms} ³ (A)	DCR max ⁴ (mOhms)	Isolation ⁵ (Vrms)
		nom	min			
CG3528-AL	6.23 @ 0.72 MHz	3.00	1.95	3.1	42.0	1000

1. When ordering, please specify **packaging** code:

CG3528-ALD

Packaging: **D** = 13" machine-ready reel. EIA-481 embossed plastic tape (250 parts per full reel). Quantities less than full reel available: in tape (not machine ready) or with leader and trailer (\$25 charge).

B = Less than full reel. In an effort to simplify our part numbering system, Coilcraft is eliminating the need for multiple packaging codes. When ordering, simply change the last letter of your part number from B to D.

- 2. Inductance shown for each winding, measured at 10 kHz, 1.0 Vrms, 0 Adc on an Agilent/HP 4263B LCR meter or equivalent.
- 3. Current per winding that causes a 40°C rise from 25°C ambient. This information is for reference only and does not represent absolute maximum ratings.
- 4. DCR is specified per winding.
- 5. Isolation (hipot) measured for two seconds.
- 6. Electrical specifications at 25°C.

Refer to Doc 362 "Soldering Surface Mount Components" before soldering.

Typical Attenuation

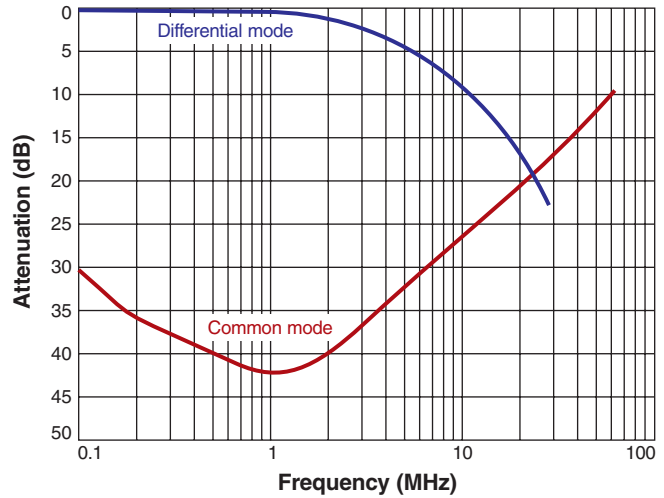

Typical Impedance versus Frequency

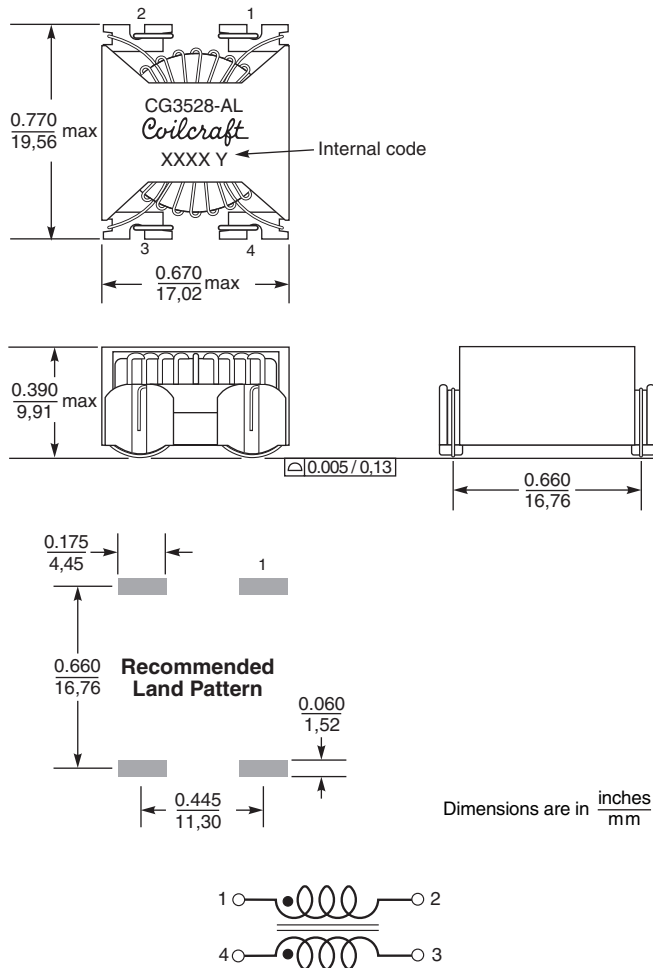
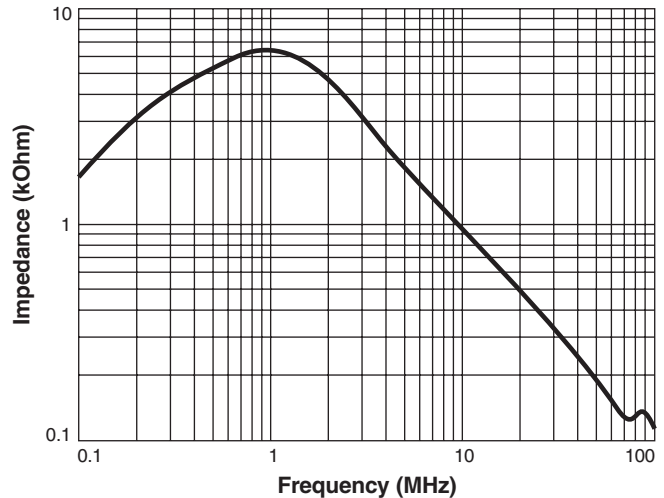

Core material Ferrite
Terminations RoHS compliant tin-silver-copper over copper
Weight 5.1 g
Ambient temperature -40°C to +85°C with I_{rms} current
Maximum part temperature +125°C (ambient + temp rise)
Storage temperature Component: -40°C to +125°C. Tape and reel packaging: -40°C to +80°C
Resistance to soldering heat Max three 40 second reflows at +260°C, parts cooled to room temperature between cycles
Moisture Sensitivity Level (MSL) 1 (unlimited floor life at <30°C / 85% relative humidity)
Packaging 250/13" reel Plastic tape: 32 mm wide, 0.5 mm thick, 24 mm pocket spacing, 10.1 mm pocket depth
PCB washing Tested to MIL-STD-202 Method 215 plus an additional aqueous wash. See [Doc787_PCB_Washing.pdf](#).



US +1-847-639-6400 sales@coilcraft.com
UK +44-1236-730595 sales@coilcraft-europe.com
Taiwan +886-2-2264 3646 sales@coilcraft.com.tw
China +86-21-6218 8074 sales@coilcraft.com.cn
Singapore + 65-6484 8412 sales@coilcraft.com.sg

Document 1194P-14 Revised 09/09/21

© Coilcraft Inc. 2021
 This product may not be used in medical or high risk applications without prior Coilcraft approval. Specification subject to change without notice. Please check web site for latest information.



Common Mode Choke – CE1759-AL

Part number ¹	Common mode impedance max (kOhms)	Inductance (mH) ²		I _{rms} ³ (A)	DCR max ⁴ (mOhms)	Isolation ⁵ (Vrms)
		nom	min			
CE1759-AL_	4.82 @ 0.99 MHz	0.81	0.52	6.0	14.0	1000

1. When ordering, please specify **packaging** code:

CE1759-ALD

Packaging: **D** = 13" machine-ready reel. EIA-481 embossed plastic tape (120 parts per full reel). Quantities less than full reel available: in tape (not machine ready) or with leader and trailer (\$25 charge).

B = Less than full reel. In an effort to simplify our part numbering system, Coilcraft is eliminating the need for multiple packaging codes. When ordering, simply change the last letter of your part number from B to D.

- 2. Inductance shown for each winding, measured at 10 kHz, 0.1 Vrms, 0 Adc on an Agilent/HP 4263B LCR meter or equivalent.
- 3. Current per winding that causes a 40°C rise from 25°C ambient. This information is for reference only and does not represent absolute maximum ratings.
- 4. DCR is specified per winding.
- 5. Isolation (hipot) measured for two seconds.
- 6. Electrical specifications at 25°C.

Refer to Doc 362 "Soldering Surface Mount Components" before soldering.

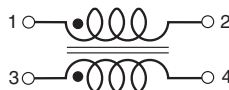
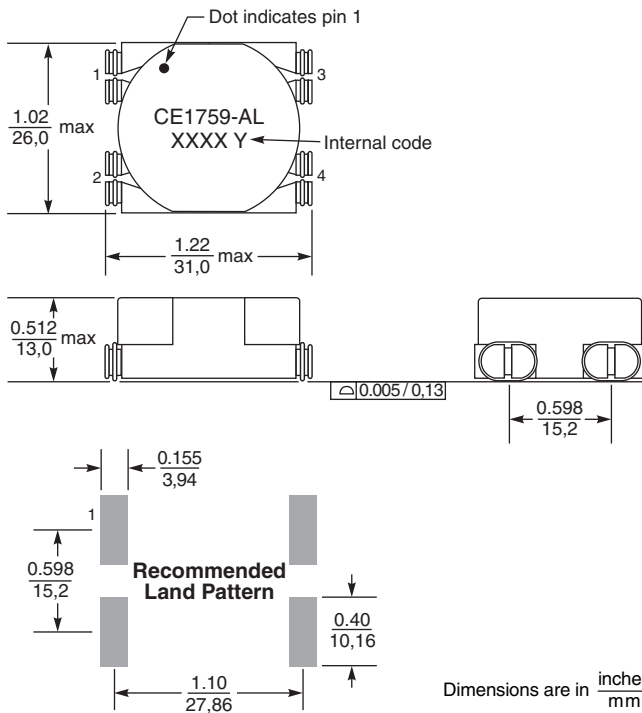

Typical Attenuation

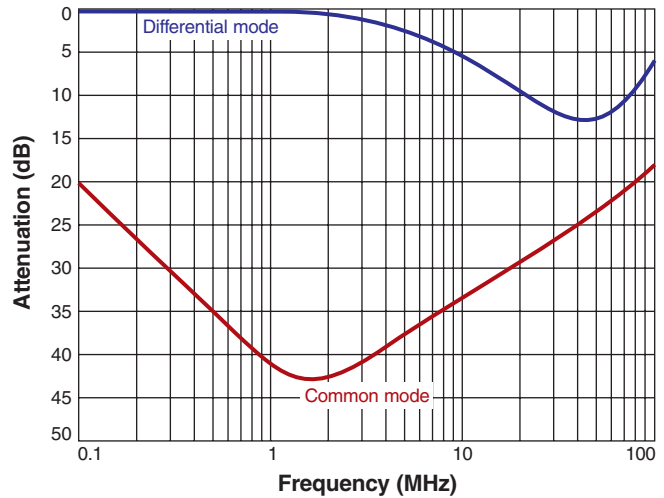

Typical Impedance versus Frequency

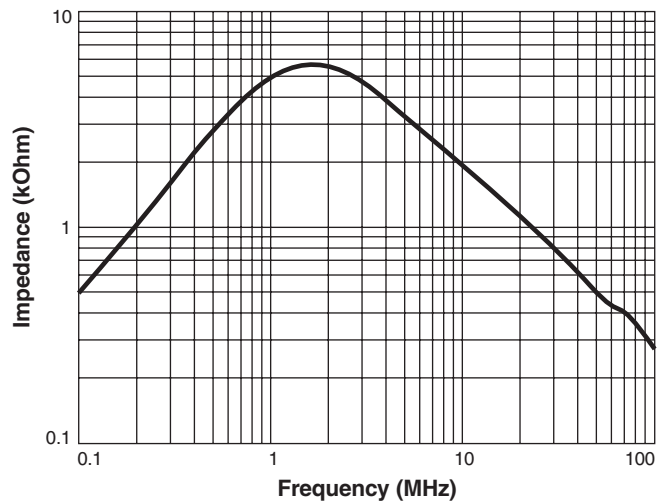

Core material Ferrite

Terminations RoHS compliant tin-silver-copper over copper

Weight 12.9 g

Ambient temperature -40°C to +85°C with I_{rms} current

Maximum part temperature +125°C (ambient + temp rise)

Storage temperature Component: -40°C to +125°C.

Tape and reel packaging: -40°C to +80°C

Resistance to soldering heat Max three 40 second reflows at

+260°C, parts cooled to room temperature between cycles

Moisture Sensitivity Level (MSL) 1 (unlimited floor life at <30°C / 85% relative humidity)

Packaging 120/13" reel Plastic tape: 44 mm wide, 0.5 mm thick, 32 mm pocket spacing, 12.4 mm pocket depth

PCB washing Tested to MIL-STD-202 Method 215 plus an additional aqueous wash. See [Doc787_PCB_Washing.pdf](#).



US +1-847-639-6400 sales@coilcraft.com
UK +44-1236-730595 sales@coilcraft-europe.com
Taiwan +886-2-2264 3646 sales@coilcraft.com.tw
China +86-21-6218 8074 sales@coilcraft.com.cn
Singapore + 65-6484 8412 sales@coilcraft.com.sg

Document 1194P-15 Revised 09/09/21

© Coilcraft Inc. 2021

This product may not be used in medical or high risk applications without prior Coilcraft approval. Specification subject to change without notice. Please check web site for latest information.



Common Mode Choke – CG3885-AL

Part number ¹	Common mode impedance max (kOhms)	Inductance (mH) ²		I _{rms} ³ (A)	DCR max ⁴ (mOhms)	Isolation ⁵ (Vrms)
		nom	min			
CG3885-AL_	3.11 @ 1.8 MHz	0.47	0.30	10.0	8.0	1000

1. When ordering, please specify **packaging** code:

CG3885-ALD

Packaging: **D** = 13" machine-ready reel. EIA-481 embossed plastic tape (120 parts per full reel). Quantities less than full reel available: in tape (not machine ready) or with leader and trailer (\$25 charge).

B = Less than full reel. In an effort to simplify our part numbering system, Coilcraft is eliminating the need for multiple packaging codes. When ordering, simply change the last letter of your part number from B to D.

- Inductance shown for each winding, measured at 10 kHz, 0.1 Vrms, 0 Adc on an Agilent/HP 4263B LCR meter or equivalent.
- Current per winding that causes a 40°C rise from 25°C ambient. This information is for reference only and does not represent absolute maximum ratings.
- DCR is specified per winding.
- Isolation (hipot) measured for two seconds.
- Electrical specifications at 25°C.

Refer to Doc 362 "Soldering Surface Mount Components" before soldering.

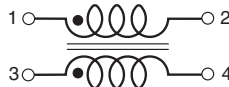
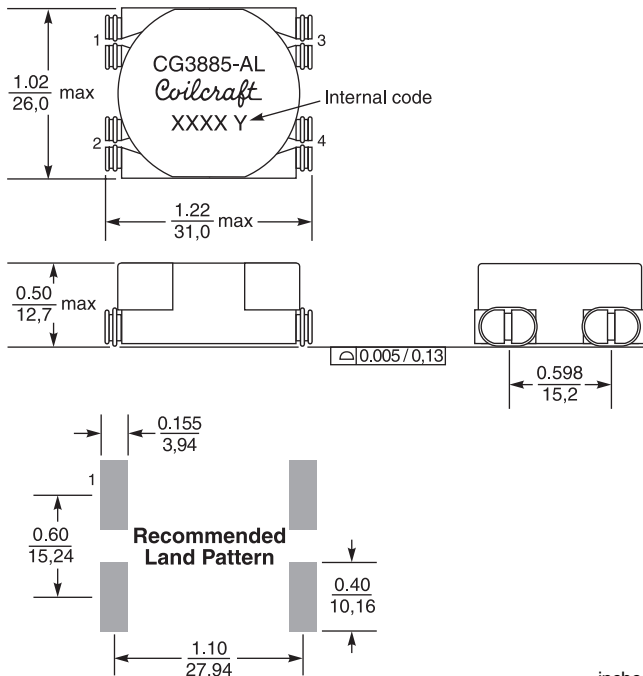

Typical Attenuation

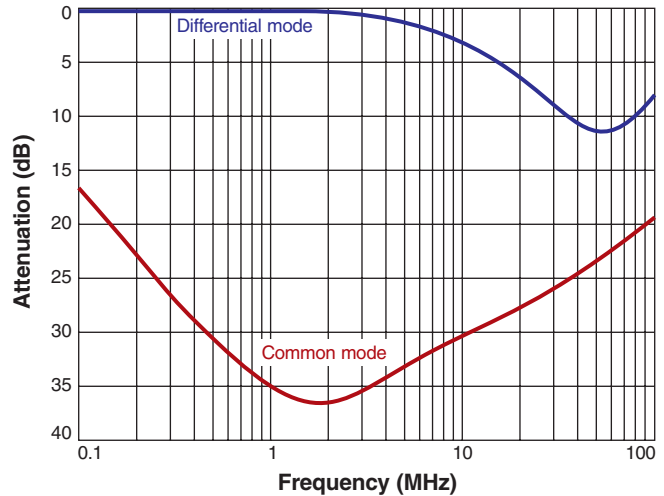

Typical Impedance versus Frequency

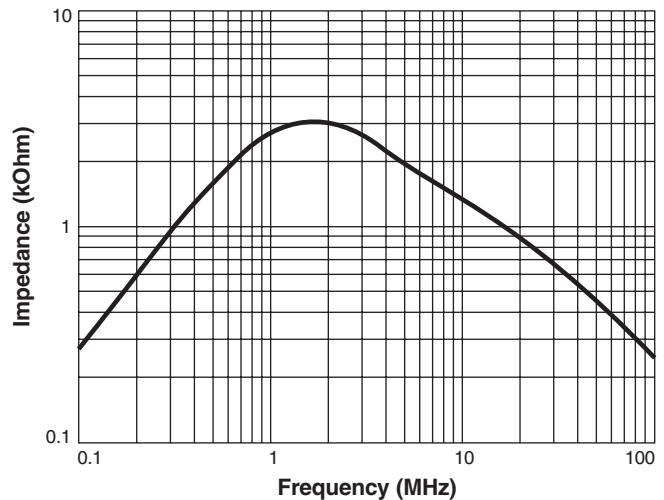

Core material Ferrite
Terminations RoHS compliant tin-silver-copper over copper
Weight 15.3 g
Ambient temperature -40°C to +85°C with I_{rms} current
Maximum part temperature +125°C (ambient + temp rise)
Storage temperature Component: -40°C to +125°C.
 Tape and reel packaging: -40°C to +80°C
Resistance to soldering heat Max three 40 second reflows at +260°C, parts cooled to room temperature between cycles
Moisture Sensitivity Level (MSL) 1 (unlimited floor life at <30°C / 85% relative humidity)
Packaging 120/13" reel Plastic tape: 44 mm wide, 0.5 mm thick, 32 mm pocket spacing, 12.4 mm pocket depth
PCB washing Tested to MIL-STD-202 Method 215 plus an additional aqueous wash. See [Doc787_PCB_Washing.pdf](#).



US +1-847-639-6400 sales@coilcraft.com
UK +44-1236-730595 sales@coilcraft-europe.com
Taiwan +886-2-2264 3646 sales@coilcraft.com.tw
China +86-21-6218 8074 sales@coilcraft.com.cn
Singapore + 65-6484 8412 sales@coilcraft.com.sg

Document 1194P-16 Revised 09/09/21

© Coilcraft Inc. 2021
 This product may not be used in medical or high risk applications without prior Coilcraft approval. Specification subject to change without notice. Please check web site for latest information.



Common Mode Choke – CF2805-AL

Part number ¹	Common mode impedance max (kOhms)	Inductance (mH) ²		I _{rms} ³ (A)	DCR max ⁴ (mOhms)	Isolation ⁵ (Vrms)
		nom	min			
CF2805-AL_	3.64 @ 1.9 MHz	0.63	0.40	6.8	14.0	1000

1. When ordering, please specify **packaging** code:

CF2805-ALD

Packaging: **D** = 13" machine-ready reel. EIA-481 embossed plastic tape (120 parts per full reel). Quantities less than full reel available: in tape (not machine ready) or with leader and trailer (\$25 charge).

B = Less than full reel. In an effort to simplify our part numbering system, Coilcraft is eliminating the need for multiple packaging codes. When ordering, simply change the last letter of your part number from B to D.

- Inductance shown for each winding, measured at 10 kHz, 0.1 Vrms, 0 Adc on an Agilent/HP 4263B LCR meter or equivalent.
- Current per winding that causes a 40°C rise from 25°C ambient. This information is for reference only and does not represent absolute maximum ratings.
- DCR is specified per winding.
- Isolation (hipot) measured for two seconds.
- Electrical specifications at 25°C.

Refer to Doc 362 "Soldering Surface Mount Components" before soldering.

Typical Attenuation

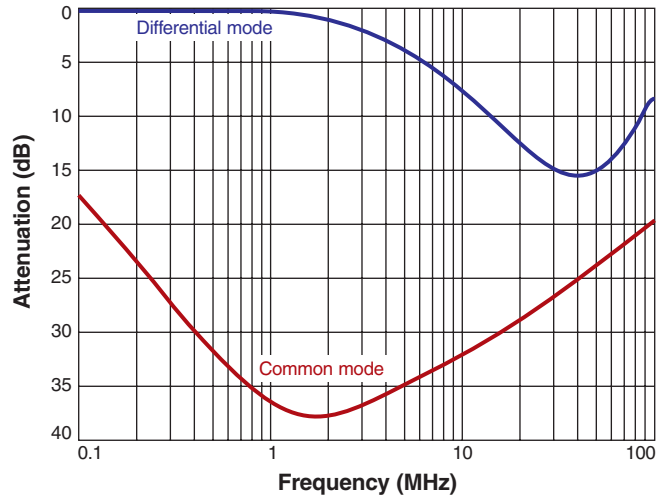

Typical Impedance versus Frequency

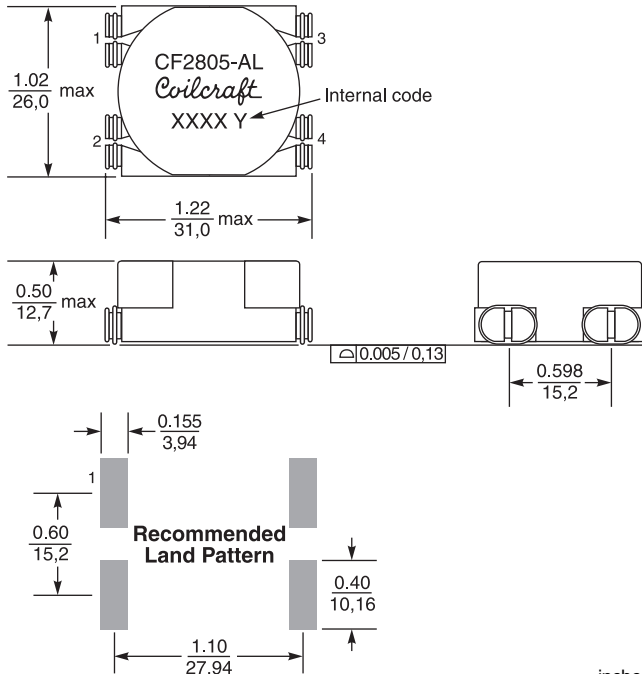
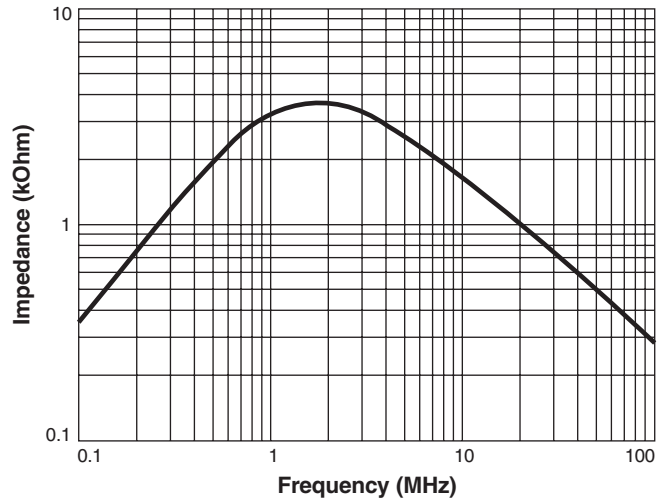

Dimensions are in $\frac{\text{inches}}{\text{mm}}$

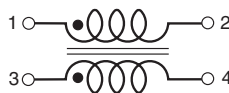

Core material Ferrite

Terminations RoHS compliant tin-silver-copper over copper

Weight 14.6 g

Ambient temperature -40°C to +85°C with I_{rms} current

Maximum part temperature +125°C (ambient + temp rise)

Storage temperature Component: -40°C to +125°C.

Tape and reel packaging: -40°C to +80°C

Resistance to soldering heat Max three 40 second reflows at +260°C, parts cooled to room temperature between cycles

Moisture Sensitivity Level (MSL) 1 (unlimited floor life at <30°C / 85% relative humidity)

Packaging 120/13" reel Plastic tape: 44 mm wide, 0.5 mm thick, 32 mm pocket spacing, 12.4 mm pocket depth

PCB washing Tested to MIL-STD-202 Method 215 plus an additional aqueous wash. See [Doc787_PCB_Washing.pdf](#).



US +1-847-639-6400 sales@coilcraft.com
UK +44-1236-730595 sales@coilcraft-europe.com
Taiwan +886-2-2264 3646 sales@coilcraft.com.tw
China +86-21-6218 8074 sales@coilcraft.com.cn
Singapore + 65-6484 8412 sales@coilcraft.com.sg

Document 1194P-17 Revised 09/09/21

© Coilcraft Inc. 2021

This product may not be used in medical or high risk applications without prior Coilcraft approval. Specification subject to change without notice. Please check web site for latest information.

X-ON Electronics

Largest Supplier of Electrical and Electronic Components

Click to view similar products for [Common Mode Chokes / Filters](#) category:

Click to view products by [Coilcraft](#) manufacturer:

Other Similar products are found below :

[74279408](#) [PE-62911NL](#) [PE-64683](#) [ST6118T-R](#) [T8114NLT](#) [RD5122-10-6M0](#) [TCM0806G-350-2P-T](#) [TCM0806G-650-2P-T](#) [IND-0110](#)
[UAL21V07012500](#) [UAL24VR06500CH](#) [UALSC023000000](#) [UALSC1020JH000](#) [UALSC1520JH000](#) [UALSU16VD30030](#)
[UALSU16VD40010](#) [UALSU9H0305000](#) [UALSU9HF060300](#) [UALSU9VD070100](#) [36-00037](#) [5701610000](#) [UALW21HS072450](#)
[UALSU9VD070400](#) [UALSU9HF050500](#) [UALSU9H0208000](#) [UALSCF25081300](#) [UAL24VK06450CH](#) [PLT10HH501100PNB](#)
[PLT10HH401100PNB](#) [PLT10HH1026R0PNB](#) [PE-67531](#) [EXC-X4CH120X](#) [TLH10UB 113 0R5](#) [2752041447](#) [2752045447](#) [CMS3-11-R](#)
[7351V](#) [CMF16-153131](#) [744252510](#) [T8116NLT](#) [FE2X10-4-2NL](#) [744253200](#) [744253101](#) [744252220](#) [TX8111NLT](#) [UAL30VR3500470](#)
[CTX01-19077-R](#) [T8003NLT](#) [CTX01-13663](#) [CTX66-19521-R](#)