



**SPECIFICATION FOR APPROVAL**

产品规格承认书

**High Current Power Inductor**

大电流功率电感

CUSTOMER.

\_\_\_\_\_

MODEL NO.

**MTM1480-100M**

\_\_\_\_\_

CUSTOMER'S PART NO.

\_\_\_\_\_

LILE NO.

\_\_\_\_\_

DATE.

**2021.12.02**

\_\_\_\_\_

REVISION.

**A/0**

\_\_\_\_\_

CUSTOMER APPROVE

\_\_\_\_\_

DATE:

DRAWING

DRAWN BY	CHECK BY	APPROVAL BY

DATE:2021.12.02



IATF16949 / ISO9001 / ISO14000

**深圳市迈翔科技有限公司**

**SHENZHEN MOTTO TECHNOLOGY Co., Ltd**

香港瑞德科技有限公司 黄冈市迈翔电子有限公司

Motto Technology park, niu e ling village no#214 xintian,nghua Town,

Guanlan Street, Longhua District,Shenzhen

TEL: +86 0755-8948751-2 89487610 Fax: +86 0755-61624574

[Http://www.coilmx.com](http://www.coilmx.com) E-mail: [sales@mottotech.com](mailto:sales@mottotech.com)



CUSTOMER		MODEL NO.	MTM1480-100M	REVISION	A/0
FILE NO.		PART NO.		DATE	2021.12.02

1.PRODUCT DIMENSION		UNIT:mm	
	A	14.9MAX	
	B	15MAX	
	C	8.1MAX	
	D	2.8+0.2	
	E	10.5TYP	
	F	2.3+0.2	
	G	2.8+0.2	
	H	9.0+0.5	

2.ELECTRICAL REQUIREMENTS			
PARAMETER	SPECIFICATION	CONDITION	TEST INSTRUMENTS
L(uH)	10± 20%	100KHz/0.25V	MICROTEST 6377
DCR(mΩ)	10MAX	At 25℃	TH16502
I sat(A)	10A TYP L0A*70%	100KHz/0.25V	MICROTEST 6377+6220
I rms(A)	10A TYP ΔT≤40℃	100KHz/0.25V	MICROTEST 6377+6220
WIRE	0.35mmT*1.8mmW*8.75TS(扁线耐温等级: ≥220℃)		

**3.CHARACTERISTICS**

- (1). All test data is based on 25℃ ambient.
- (2). DC current(A)that will cause an approximate ΔT40℃
- (3). DC current(A)that will cause L0 to drop approximately 30%Typ
- (4). Operating temperature range: -40℃~+125℃
- (5).The part temperature (ambient + temp rise)should not exceed 125℃ under worst case operating conditions. circuit design, component.PWB trace size and thickness,airflow and other cooling provision all affect the part temperature. Part temperature should be verified in the den application

**4.SPECIAL REQUEST**

- (1)Lettering 100 on top of the body.

<b>CUSTOMER</b>		<b>MODEL NO.</b>	<b>MTM1480-100M</b>	<b>REVISION</b>	<b>A/0</b>
<b>FILE NO.</b>		<b>PART NO.</b>		<b>DATE</b>	<b>2021.12.02</b>

**5.PRODUCT IDENTIFICATION**

XX XXXX - XXX X X

① ② ③ ④ ⑤

①、 Product Symbol ②、 Dimensions ③、 Inductance

④、 Tolerance: M±20%, N±30%. ⑤、 Material

**6.ELECTRICAL SCHEMATICS**

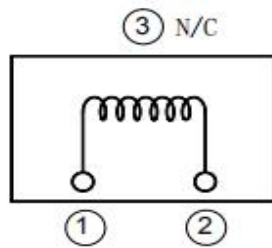

**7.APPLICATION**

- (1)Low profile,high current power supplies.
- (2)Battery powered devices.
- (3)DC/DC converters in distributed power systems.
- (4)DC/DC converters for field programmable gate array.

**8.FEATURES**

- (1)Assemblage design, sturdy structure.
- (2)High inductance, high current, low magnetic loss,low ESR, small parasitic capacitance.
- (3)Flat wire winding, achieve a low D.C. Resistance.
- (4)Temperature rise current and saturation current is less influenced by environment.

**9.RECOMMENDED PCB LAYOUT**

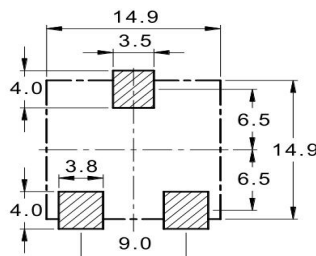

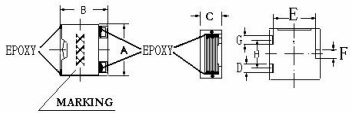
CUSTOMER		MODEL NO.			MTM1480-100M		REVISION		A/0	
FILE NO.		PART NO.					DATE		2021.12.02	
SORT	ITEM	A	B	C	D	E	F	H		
PRODUCT & DIMENSION	SPEC	14.9MAX	15MAX	8.1MAX	2.8+0.2	10.5TYP	2.3+0.2	9.0+0.5		
	1	14.56	14.85	8.02	2.81	10.45	2.35	9.03		
	2	14.58	14.88	8.02	2.82	10.45	2.35	9.01		
	3	14.60	14.87	8.04	2.82	10.45	2.34	9.02		
	4	14.53	14.86	8.03	2.81	10.50	2.36	9.06		
	5	14.62	14.83	8.07	2.83	10.46	2.32	9.05		
	X	14.58	14.86	8.04	2.82	10.46	2.34	9.03		
	R	0.09	0.05	0.05	0.02	0.05	0.04	0.05		
ELECTRICAL & REQUIREMENTS	ITEM	L(μH)	DCR (mΩ)	I sat(A)	DC BIAS	I <sub>rms</sub>	SHAPE:			
	SPEC	10± 20%	10MAX	10A TYP LOA*70%		10A TYP ΔT≤40°C				
	1	9.73	8.55	9.18	-5.7%	OK				
	2	9.42	8.56	9.01	-4.4%	OK				
	3	9.64	8.57	9.11	-5.5%	OK				
	4	9.42	8.65	9.00	-4.5%	OK				
	5	9.62	8.69	9.12	-5.2%	OK				
	X	9.57	8.60	9.08	-5.0%					
	R	0.31	0.14	0.18	1.3%					

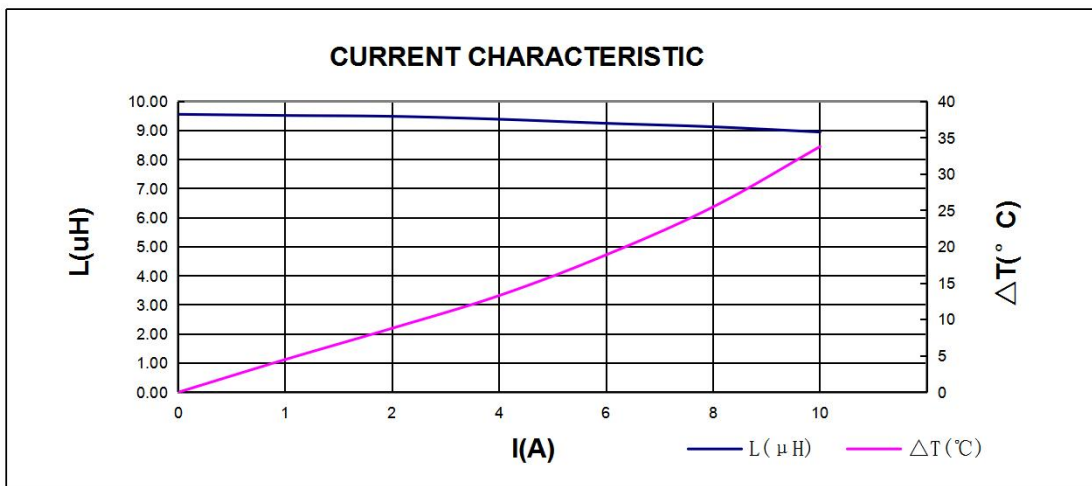

CUSTOMER		MODEL NO.	MTM1480-100M	REVISION	A/0
FILE NO.		PART NO.		DATE	2021.12.02
<b>11.可靠性Reliability</b>					
项目Item	规格与需求 Specification and Requirement		测试方法Test Method		
可焊性 Solderability test	沾锡面积不得小于95%上锡面 Terminals area must have 95% min solder coverage		上锡升温曲线Solder heat proof: (1) 预热: 160±10℃持续90s Preheating: 160±10℃ for 90 seconds (2) 恒温时段: 245±5℃持续2±0.5s Retention time: 245±5℃ for 2±0.5 seconds		
振动测试 Vibration test	感值变化: 不超过±5% 且无破裂等机械损伤产生 Inductance change: Within±5% Without mechanical damage such as break		(1) 振动频率(10Hz 55Hz 10Hz)60s为一个周期 Vibration frequency: (10Hz to 55Hz to 10Hz) in 60 seconds as a period (2) 振动时间 Vibration time: 三维正交坐标系每个方向振动(周期)循环2小时 Period cycled for 2 hours in each of 3 mutual perpendicular directions (3) 振幅 Amplitude: 1.5 mm Max		
冲击测试 Shock test	感值变化: 不超过±5% 且无破裂等机械损伤产生 Inductance change: Within±5% Without mechanical damage such as break		(1) 最大振幅 Peak value: 100G (2) 脉冲波长 Duration of pulse: 11ms (3) 三维正交坐标系每个方向正负方向冲击3次 Times in each positive and negative direction of 3 mutual perpendicular directions		
冷热冲击 Thermal shock	感值变化: 不超过±5% 且无破裂等机械损伤产生 Inductance change: Within±5% Without mechanical damage such as break		(1)重复以上100个循环Repeat 100 cycle as follow (-40±2℃,30±3分钟) 室温5分钟 (-40±2℃,30±3 minutes) Room temperature,5 minutes (+125±2℃,30±3分钟) 室温5分钟 (+125±2℃,30±3 minutes) Room temperature,5 minutes (2)恢复: 测试于标准条件下恢复48+4/-0小时 (参考注释1) Recovery:48+4/-0 hours of recovery under the standard condition after the test. (see Note1)		
耐高温测试 High temperature life test	感值变化: 不超过±5% 且无破裂等机械损伤产生 Inductance change: Within±5% Without mechanical damage such as break		(1)环境条件: 85±2℃ Environment condition : 85±2℃ 应用电流: 额定电流 Applied current: Rated current (2)持续时间: 1000+4/-0 小时 (参考注释1) Duration:1000+4/-0 hours (see Note1)		
耐湿测试 Humidity Resistance	感值变化: 不超过±5% 且无破裂等机械损伤产生 Inductance change: Within±5% Without mechanical damage such as break		(1)环境条件: 60±2℃ Environment condition : 60±2℃ 湿度: 90~95% Humidity:90~95% 应用电流: 额定电流 Applied current: Rated current (2)持续时间: 1000+4/-0 小时 (参考注释1) Duration:1000+4/-0 hours (see Note1)		
低温存放测试 Low temperature life test	感值变化: 不超过±5% 且无破裂等机械损伤产生 Inductance change: Within±5% Without mechanical damage such as break		(1)存储温度 Store temperature -40±2℃下存放 1000+4/-0 小时 -40±2℃for total 1000+4/-0 hours		
高温存放测试 High temperature life test	感值变化: 不超过±5% 且无破裂等机械损伤产生 Inductance change: Within±5% Without mechanical damage such as break		(1)存储温度 Store temperature +125±2℃下存放 1000+4/-0 小时 +125±2℃for total 1000+4/-0 hours		

CUSTOMER		MODEL NO.	MTM1480-100M	REVISION	A/0
FILE NO.		PART NO.		DATE	2021.12.02

12、包装 Packaging

12.1 包装料带尺寸 Tape packaging dimensions

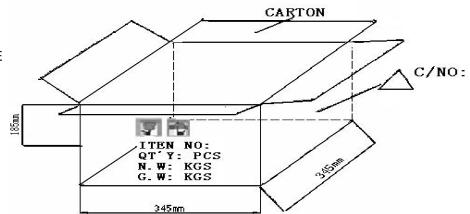
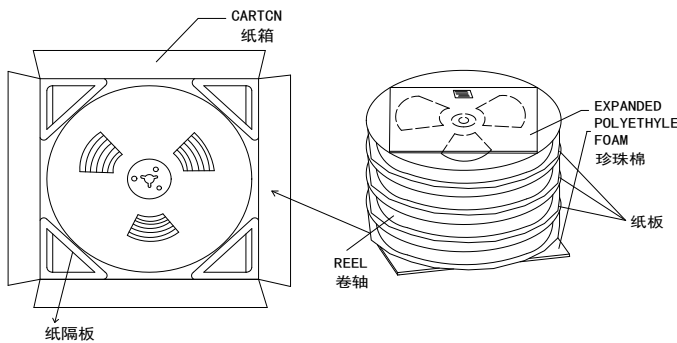
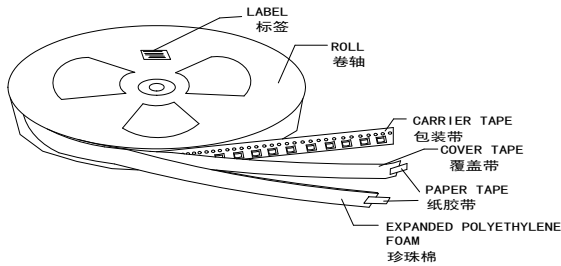
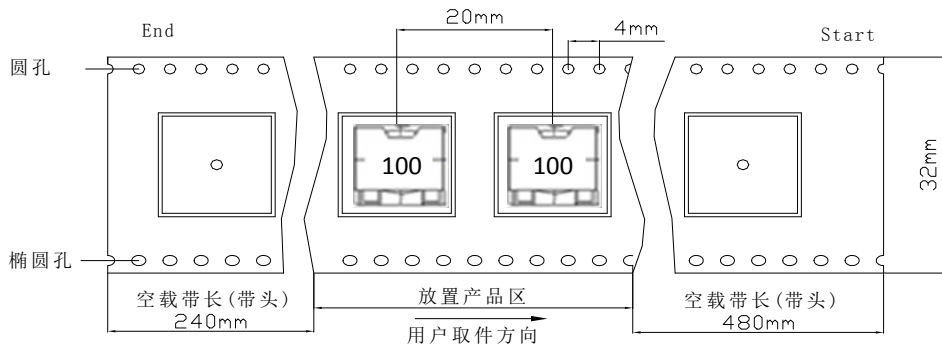

内包装 (INNER)	REEL(卷轴+载带+自粘带+标签+美纹胶带)	300 PCS/ROLL ( 300个/卷)
外包装 (OUTER)	4 ROLLS/CARTON ( 4卷/外箱 )	4 ROLLS/CARTON ( 4卷/外箱 )

CUSTOMER		MODEL NO.	MTM1480-100M	REVISION	A/0
FILE NO.		PART NO.		DATE	2021.12.02

Reflow curve

※ Reflow Profile

Power Choke Coil Type

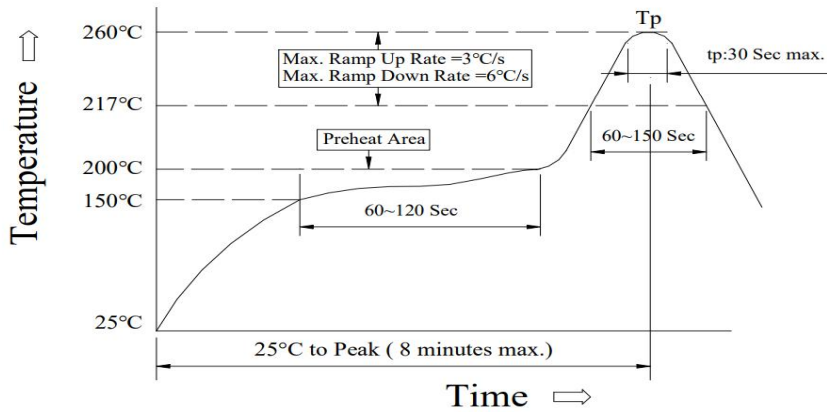

1. Reflow Soldering Method

Reflow Soldering	Tp:255~260°C	Max.30 seconds ( tp )
	217°C	60~150 seconds
Pre-Heat	150 ~ 200°C	60~120 seconds
Time 25°C to peak temperature	8 minutes max.	

2. Soldering iron method : 350±5°C Max.3 seconds.



## X-ON Electronics

Largest Supplier of Electrical and Electronic Components

*Click to view similar products for [Fixed Inductors](#) category:*

*Click to view products by [COILMX](#) manufacturer:*

Other Similar products are found below :

[CR32NP-100KC](#) [CR54NP-470LC](#) [70F224AI](#) [MGDQ4-00004-P](#) [MHQ1005P10NJ](#) [MHQ1005P1N0S](#) [MHQ1005P2N4S](#) [MHQ1005P3N6S](#)  
[MHQ1005P5N1S](#) [MHQ1005P8N2J](#) [PE-53601NL](#) [PE-53602NL](#) [PG0936.113NLT](#) [9220-20](#) [9310-16](#) [PM06-2N7](#) [PM06-39NJ](#) [A01TK](#)  
[1206CS-471XJ](#) [HC2-R47-R](#) [HC8-1R2-R](#) [HCF1305-3R3-R](#) [1206CS-151XG](#) [RCH664NP-140L](#) [RCH664NP-4R7M](#) [RCP1317NP-391L](#)  
[RCR110DNP-331L](#) [DH2280-4R7M](#) [DS1608C-106](#) [B10TJ](#) [B82498B3101J000](#) [ELJ-RE27NJF2](#) [1812CS-153XJ](#) [1812CS-183XJ](#) [1812CS-](#)  
[223XJ](#) [1812LS-104XJ](#) [1812LS-105XJ](#) [1812LS-124XJ](#) [1812LS-154XJ](#) [1812LS-223XJ](#) [1812LS-224XJ](#) [1812LS-563XJ](#) [1812LS-683XJ](#)  
[1812LS-824XJ](#) [NIN-FB101JTR110F](#) [NIN-FB471JTR62F](#) [NIN-FC1R5JTR220F](#) [NIN-HCR15JTRF](#) [NIN-HCR33JTRF](#) [NIN-HDR22JTRF](#)