

1N5400-G Thru. 1N5408-G

Voltage: 50 to 1000 V

Current: 3.0 A

RoHS Device

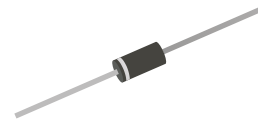

Features

- Low forward voltage drop.
- High reliability.
- High current capability.
- High surge current capability.

Mechanical data

- Case: Molded plastic
- Epoxy: UL 94V-0 rate flame retardant
- Polarity: Color band denotes cathode end
- Lead: Axial leads, solderable per MIL-STD-202, method 208 guaranteed
- Mounting position: Any
- Weight: 1.2 grams

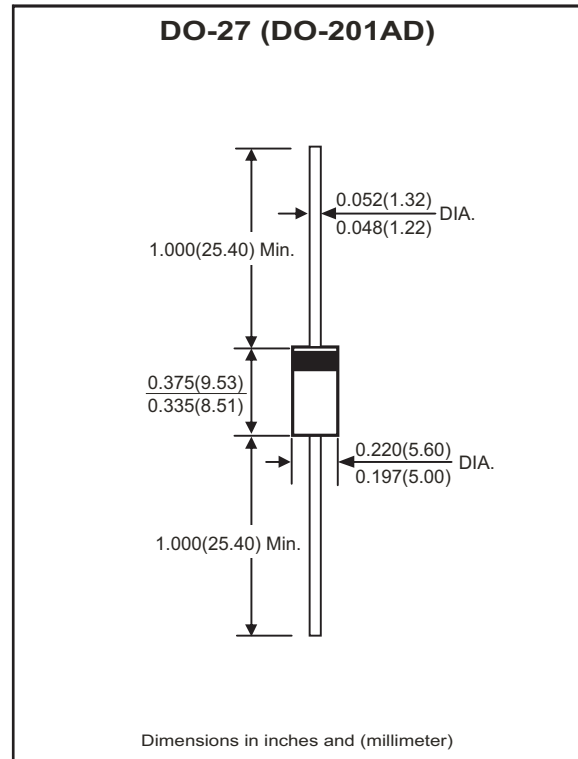

Maximum Ratings and Electrical Characteristics (at $T_A=25^\circ\text{C}$ unless otherwise noted)

Ratings at 25°C ambient temperature unless otherwise specified.
Single phase, half wave, 60Hz, resistive or inductive load.
For capacitive load, derate current by 20%.

Parameter	Symbol	1N5400 -G	1N5401 -G	1N5402 -G	1N5404 -G	1N5406 -G	1N5407 -G	1N5408 -G	Unit
Maximum repetitive peak reverse voltage	V_{RRM}	50	100	200	400	600	800	1000	V
Maximum RMS voltage	V_{RMS}	35	70	140	280	420	560	700	V
Maximum DC blocking voltage	V_{DC}	50	100	200	400	600	800	1000	V
Maximum average forward rectified current .375" (9.5mm) Lead length @ $T_A=75^\circ\text{C}$	$I_{F(AV)}$	3.0							A
Peak forward surge current, 8.3ms single half sine-wave superimposed on rated load (JEDEC method)	I_{FSM}	200							A
Maximum instantaneous forward voltage @3.0A	V_F	1.0							V
Maximum DC reverse current at rated DC blocking voltage	@ $T_J=25^\circ\text{C}$	5.0							μA
	@ $T_J=100^\circ\text{C}$	100							
Typical thermal resistance (Note 1)	$R_{\theta JA}$	18							$^\circ\text{C/W}$
Operating temperature range	T_J	-65 to +125							$^\circ\text{C}$
Storage temperature range	T_{STG}	-65 to +150							$^\circ\text{C}$

NOTES:

1. Thermal resistance from junction to ambient 0.375" (9.5mm) lead length.

Rating and Characteristic Curves (1N5400-G Thru. 1N5408-G)

Fig.1 - Maximum Forward Current Derating Curve

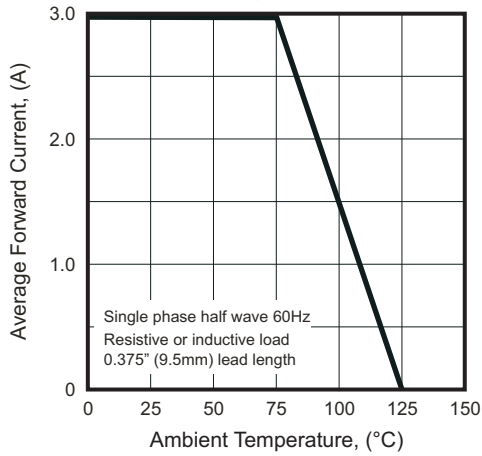

Fig.2 - Typical Instantaneous Forward Characteristics Per Bridge Element

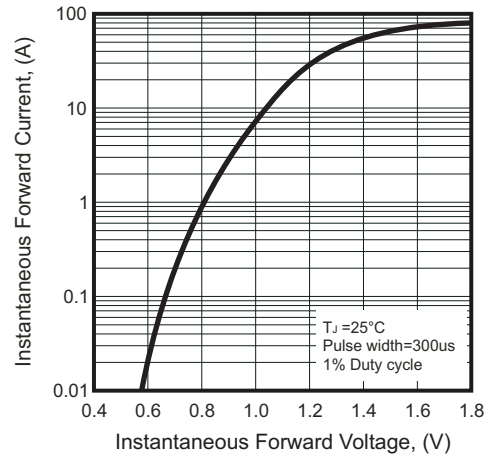

Fig.3 - Maximum Non-repetitive Forward Surge Current Per Bridge Element

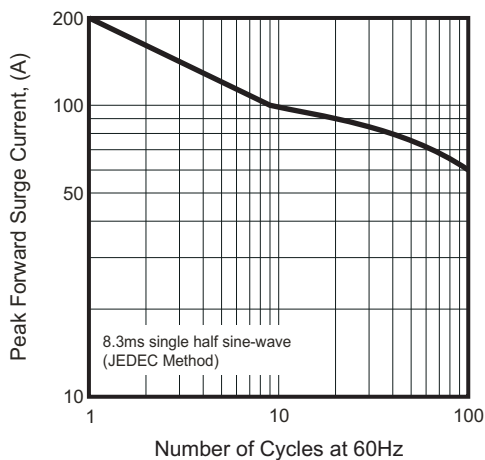
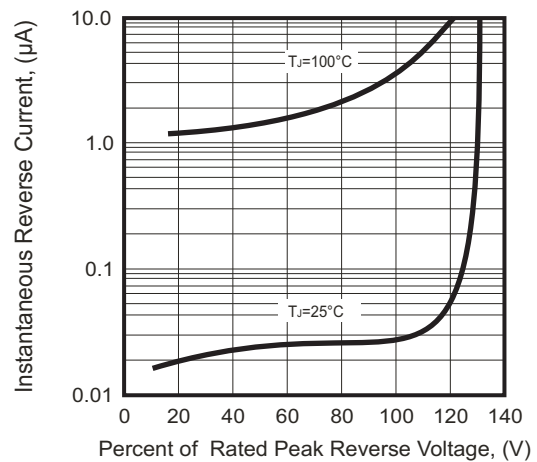
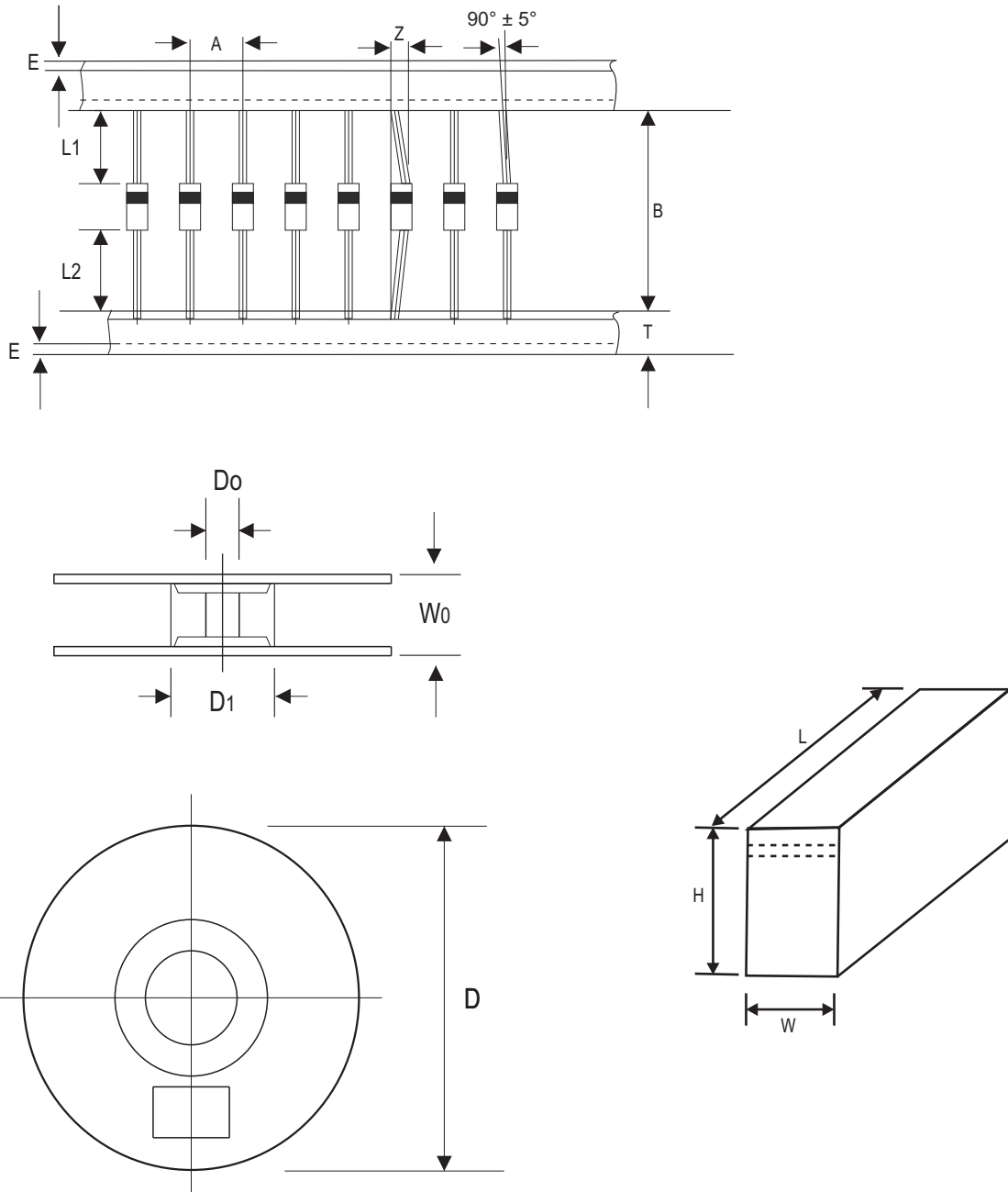

Fig.4 - Typical Reverse Characteristics Per Bridge Element



Taping Specification For Axial Lead Diodes



DO-27 (DO-201AD)	SYMBOL	A	B	Z	T	E	L1	L2
	(mm)	10.00 ± 0.50	52.00 ± 0.50	1.20 (max)	6.00 ± 0.40	1.00 (max)	1.00 (max)	1.00 (max)
	(inch)	0.394 ± 0.020	2.047 ± 0.020	0.047 (max)	0.236 ± 0.016	0.039 (max)	0.039 (max)	0.039 (max)

DO-27 (DO-201AD)	SYMBOL	D1	D0	D	W0	L	W	H
	(mm)	85.70 ± 0.30	16.60 ± 0.40	330.00	72.00 ± 3.00	260.00	75.00	145.00
	(inch)	3.374 ± 0.012	0.654 ± 0.016	13.000	2.835 ± 0.118	10.236	2.953	5.709

Marking Code

Part Number	Marking code	Packaging
1N5400-G	1N5400	AMMO
1N5401-G	1N5401	AMMO
1N5402-G	1N5402	AMMO
1N5404-G	1N5404	AMMO
1N5406-G	1N5406	AMMO
1N5407-G	1N5407	AMMO
1N5408-G	1N5408	AMMO
1N5400T-G	1N5400	REEL
1N5401T-G	1N5401	REEL
1N5402T-G	1N5402	REEL
1N5404T-G	1N5404	REEL
1N5406T-G	1N5406	REEL
1N5407T-G	1N5407	REEL
1N5408T-G	1N5408	REEL



XX = Product type marking code

Note:

1) Suffix code after part number to specify packaging item .

Packaging	Code
AMMO PACK	NA
REEL PACK	T

Standard Packaging

Case Type	AMMO PACK	
	BOX (pcs)	CARTON (pcs)
DO-27 (DO-201AD)	1,200	12,000

Case Type	REEL PACK	
	REEL (pcs)	Reel Size (inch)
DO-27 (DO-201AD)	1,200	13

X-ON Electronics

Largest Supplier of Electrical and Electronic Components

Click to view similar products for [Small Signal Switching Diodes](#) category:

Click to view products by [Comchip](#) manufacturer:

Other Similar products are found below :

[BAS16E6433HTMA1](#) [SHN2D02FUTW1T1G](#) [BAS 16-02L E6327](#) [BAS 16-02V H6327](#) [BAS 21U E6327](#) [BAS 28 E6327](#) [BAW56DWQ-7-F](#)
[BAW56M3T5G](#) [IDW40E65D1](#) [IDW40E65D2](#) [SMMSD4148T3G](#) [NSVDAN222T1G](#) [CDSZC01100-HF](#) [BAS28-7](#) [JANTX1N6640](#)
[BAW56HDW-13](#) [BAV99TQ-13-F](#) [SMSD1002T1G](#) [LS4148](#) [IDV15E65D2](#) [W0503RH200S0L](#) [M0268SJ200NLF](#) [M0268RJ200NLF](#)
[DAN217U-TP](#) [BAV21W-HE3_A-08](#) [BAV99-HE3_A-08](#) [BAW56-HE3_A-08](#) [BAS16-HE3_A-08](#) [BAS16D-HE3_A-08](#) [BAV19W-HE3_A-08](#)
[BAS20-HE3_A-08](#) [BAL99-HE3_A-08](#) [BAV23C-HE3_A-08](#) [DHVSD3004BRM-7](#) [DLLFSD01LP3Q-7](#) [BAS16VVQ-7](#)
[IDWD100E120D7XKSA1](#) [IDWD120E120D7XKSA1](#) [IDWD140E120D7XKSA1](#) [IDWD30E120D7XKSA1](#) [IDWD40E120D7XKSA1](#)
[IDWD50E120D7XKSA1](#) [IDWD60E120D7XKSA1](#) [IDWD75E120D7XKSA1](#) [BAS21TWQ-7](#) [BAV21WQ-7-F](#) [MMBD4448HADWQ-7-F](#)
[1N4148WSQ-13-F](#) [BAW56WQ-7-F](#) [BAS716-TP](#)