

A1N4148WT-HF

RoHS Device

Halogen Free

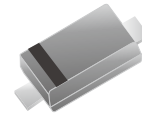

Features

- Fast switching speed.
- Ultra-small surface mount package.
- For general purpose switching applications.
- High conductance.
- AEC-Q101 Qualified.

Mechanical data

- Case: Molded plastic, SOD-523

Circuit Diagram

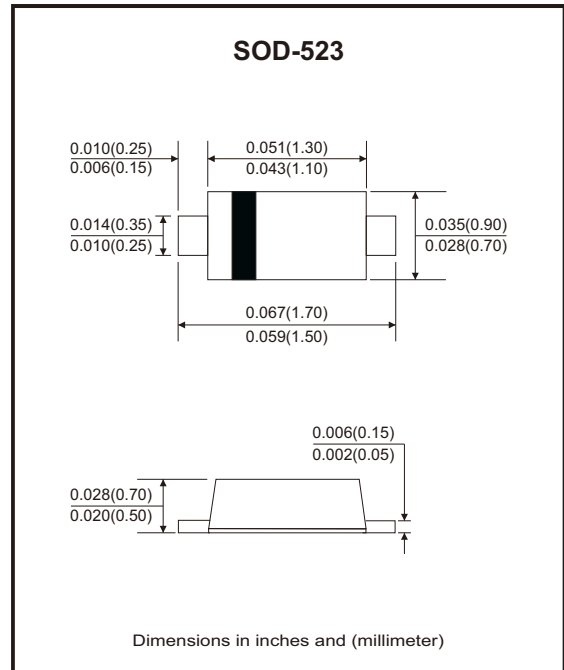

Maximum Rating (at Ta=25°C unless otherwise noted)

Parameter	Symbol	Value	Unit
Non-repetitive peak reverse voltage	V_{RM}	100	V
Reverse voltage	V_R	75	V
RMS reverse voltage	$V_{R(RMS)}$	75	V
Average rectified output current	I_o	125	mA
Non-repetitive peak forward surge current	I_{FSM}	@ t=1μs 2.0	A
		@ t=100ms 1.0	
Total power dissipation	P_{tot}	150	mW
Thermal resistance junction to ambient air	$R_{θJA}$	833	°C/W
Thermal resistance junction to lead	$R_{θJL}$	829	°C/W
Thermal resistance junction to case	$R_{θJC}$	561	°C/W
junction temperature range	T_J	-65 to +150	°C
Storage temperature range	T_{STG}	-65 to +150	°C

Electrical Characteristics (at Ta=25°C unless otherwise noted)

Parameter	Symbol	Conditions	Min	Max	Unit
Reverse breakdown voltage	$V_{(BR)R}$	$I_R = 1.0\mu A$	75		V
Forward voltage	V_F	$I_F = 1mA$ $I_F = 10mA$ $I_F = 50mA$ $I_F = 150mA$		0.715 0.855 1.0 1.25	V
Reverse current	I_R	$V_R = 75V$ $V_R = 20V$		1.0 25	μA nA
Diode capacitance	C_d	$V_R = 0V, f = 1MHz$		2.0	pF
Reverse recovery time	t_{rr}	$I_F = I_R = 10mA, I_{rr} = 0.1 \times I_R, R_L = 100\Omega$		4.0	nS

Rating and Characteristic Curves (A1N4148WT-HF)

Fig.1 - Derating Curve

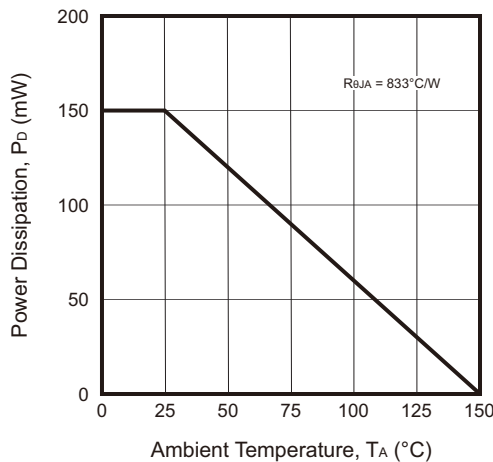

Fig.2 - Forward Characteristics

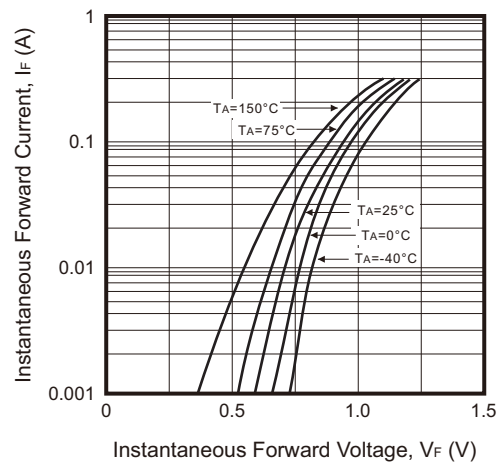

Fig.3 - Typical Reverse Characteristics

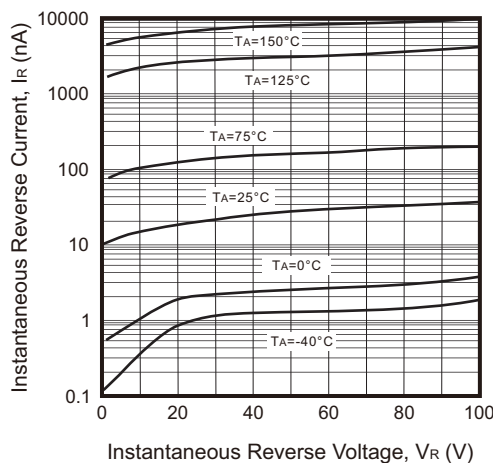
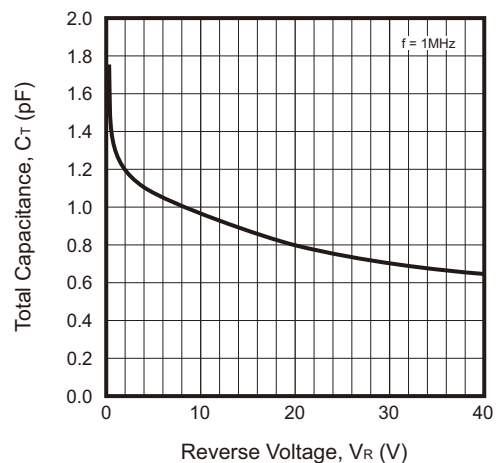

Fig.4 - Typical Capacitance vs. Reverse Voltage



Company reserves the right to improve product design, functions and reliability without notice.

REV:A

Reel Taping Specification

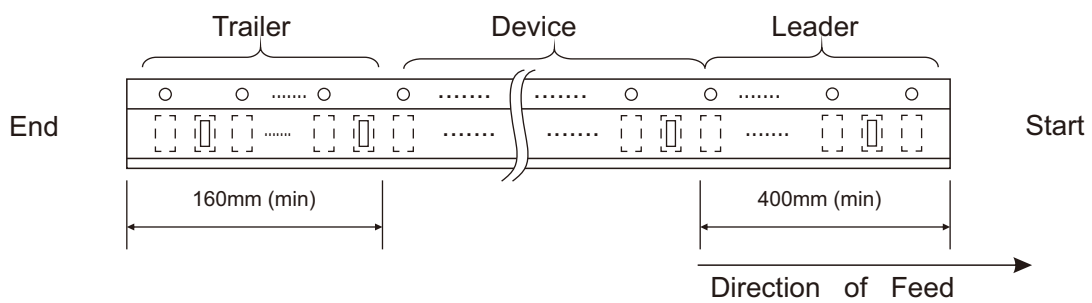
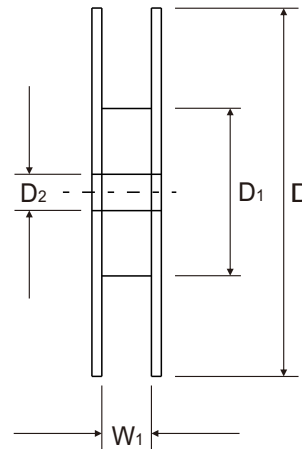
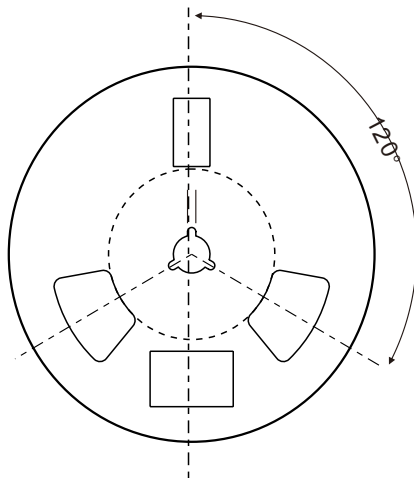
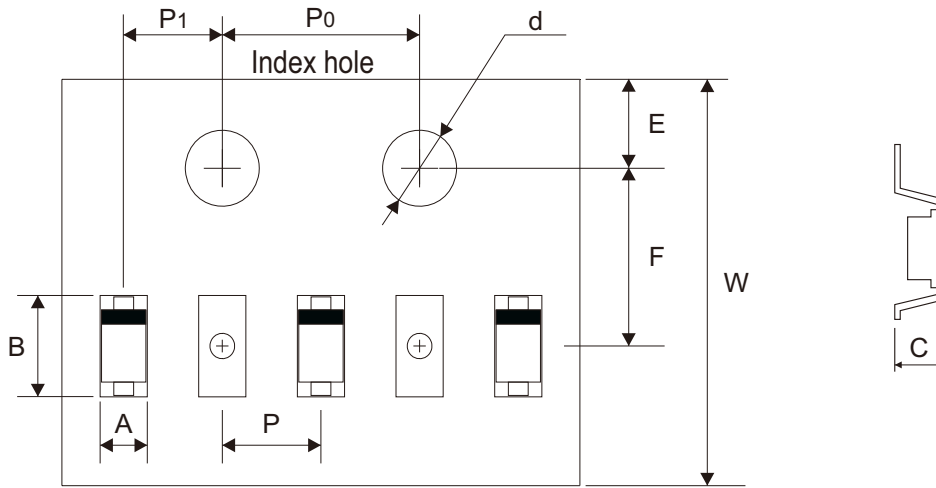

SOD-523	SYMBOL	A	B	C	d	D	D1	D2
	(mm)	0.96 ± 0.05	1.94 ± 0.05	0.73 ± 0.05	$1.50 + 0.10$	178 ± 1.00	54.00 ± 0.50	13.00 ± 0.50
	(inch)	0.038 ± 0.002	0.076 ± 0.002	0.029 ± 0.002	$0.059 + 0.004$	7.008 ± 0.039	2.126 ± 0.020	0.512 ± 0.020

SOD-523	SYMBOL	E	F	P	P0	P1	W	W1
	(mm)	1.75 ± 0.10	3.50 ± 0.05	2.00 ± 0.05	4.00 ± 0.10	2.00 ± 0.05	$8.00 + 0.30$ $- 0.10$	9.50 ± 1.00
	(inch)	0.069 ± 0.004	0.138 ± 0.002	0.079 ± 0.002	0.157 ± 0.004	0.079 ± 0.002	$0.315 + 0.012$ $- 0.004$	0.374 ± 0.039

Company reserves the right to improve product design, functions and reliability without notice.

REV:A

Marking Code

Part Number	Marking Code
A1N4148WT-HF	T4

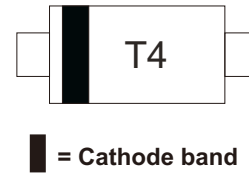

Suggested PAD Layout

SIZE	SOD-523	
	(mm)	(inch)
A	0.40	0.016
B	0.40	0.016
C	1.40	0.055

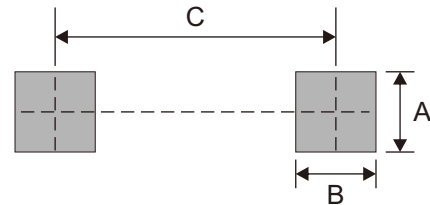

Note: 1. The pad layout is for reference purposes only.

Standard Packaging

Case Type	REEL PACK	
	REEL (pcs)	Reel Size (inch)
SOD-523	3,000	7

X-ON Electronics

Largest Supplier of Electrical and Electronic Components

Click to view similar products for [Diodes - General Purpose, Power, Switching category](#):

Click to view products by [Comchip manufacturer](#):

Other Similar products are found below :

[RD0306T-H](#) [BAV17-TR](#) [BAV19-TR](#) [1N3611](#) [NTE156A](#) [NTE525](#) [NTE571](#) [NTE5804](#) [NTE5806](#) [NTE6244](#) [1SS181-TP](#) [1SS193,LF](#)
[1SS400CST2RA](#) [SDAA13](#) [SHN2D02FUTW1T1G](#) [LS4151GS08](#) [1N4449](#) [1N456A](#) [1N4934-E3/73](#) [1N914B](#) [1N914BTR](#) [RFUH20TB3S](#)
[BAS 28 E6327](#) [BAV199-TP](#) [BAW56DWQ-7-F](#) [BAW75-TAP](#) [MM230L-CAA](#) [IDW40E65D1](#) [JAN1N3600](#) [LL4151-GS18](#) [053684A](#)
[SMMSD4148T3G](#) [707803H](#) [NSVDAN222T1G](#) [SP000010217](#) [CDSZC01100-HF](#) [BAV199E6433HTMA1](#) [BAV70M3T5G](#) [SMBT2001T1G](#)
[NTE5801](#) [NTE5800](#) [NTE5808](#) [NTE6240](#) [NTE6248](#) [BAS28-7](#) [BAW56HDW-13](#) [BAS28 TR](#) [VS-HFA04SD60STR-M3](#)
[NSVM1MA152WKT1G](#) [BAV99TQ-13-F](#)